

AD-A097 729

ELECTRONICS ENGINEERING GROUP (1842ND) SCOTT AFB IL F/G 13/13  
LIGHTNING PROBLEMS AT BUILDING 1409 (CONTROL TOWER), MAXWELL AI--ETC(U)  
MAR 81 J F ZYCH  
1842 EEG./EEIS6-TR-81-11

NL

UNCLASSIFIED

1 OF 1  
AD A  
097729

END
DATE
FILED
5-81
DTIC

LEVEL IV

(1)

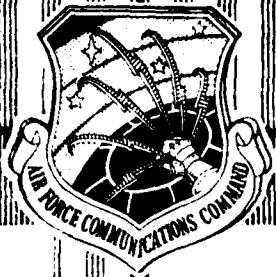

14 1842 EEG/EEISG-TR-81-11

AD A 097 729



DTIC ELECTE APR 14 1981 D

AFCC TECHNICAL REPORT

6 LIGHTNING PROBLEMS AT BUILDING 1409 (CONTROL TOWER), MAXWELL AFB, ALABAMA.

10 John F. Ryck...

11 Mar 71 12 22

SUPPORT ENGINEERING BRANCH ELECTRONICS ENGINEERING GROUP (AFCC) SCOTT AFB, ILLINOIS 62225

DTIC FILE COPY

DISTRIBUTION STATEMENT A Approved for public release; Distribution Unlimited

30 MARCH 1981

81 4 13 078

44964681 4 13 078

## 1842 ELECTRONICS ENGINEERING GROUP

### MISSION

The 1842 Electronics Engineering Group (EEG) has the mission to provide communications-electronics-meteorological (CEM) systems engineering and consultive engineering support for AFCC. In this respect, 1842 EEG responsibilities include: Developing engineering and installation standards for use in planning, programming, procuring, engineering, installing and testing CEM systems, facilities and equipment; performing systems engineering of CEM requirements that must operate as a system or in a system environment; operating a specialized Digital Network System Facility to analyze and evaluate new digital technology for application to the Defense Communications System (DCS) and other special purpose systems; operating a facility to prototype systems and equipment configurations to check out and validate engineering-installation standards and new installation techniques; providing consultive CEM engineering assistance to HQ AFCC, AFCC Areas, MAJCOMS, DOD and other government agencies.

REPORT DOCUMENTATION PAGE		READ INSTRUCTIONS BEFORE COMPLETING FORM	
1. REPORT NUMBER 1842 EEG/EEIS TR	2. GOVT ACCESSION NO. AD-A097	3. REPORT'S CATALOG NUMBER 729 N/A	
4. TITLE (and Subtitle) Lightning Problems at Bldg 1409 Control Tower, Maxwell AFB AL		5. TYPE OF REPORT & PERIOD COVERED N/A	
		6. PERFORMING ORG. REPORT NUMBER N/A	
7. AUTHOR(s) John F. Zych		8. CONTRACT OR GRANT NUMBER(s) N/A	
9. PERFORMING ORGANIZATION NAME AND ADDRESS 1842 EEG/EEIS Scott AFB, IL 62225		10. PROGRAM ELEMENT, PROJECT, TASK AREA & WORK UNIT NUMBERS	
11. CONTROLLING OFFICE NAME AND ADDRESS 1842 EEG/EEIS Scott AFB, IL 62225		12. REPORT DATE Mar 1981	
		13. NUMBER OF PAGES	
14. MONITORING AGENCY NAME & ADDRESS (if different from Controlling Office)		15. SECURITY CLASS. (of this report) Unclassified	
		15a. DECLASSIFICATION/DOWNGRADING SCHEDULE	
16. DISTRIBUTION STATEMENT (of this Report)  Approved for public release. Distribution unlimited.			
17. DISTRIBUTION STATEMENT (of the abstract entered in Block 20, if different from Report)  N/A			
18. SUPPLEMENTARY NOTES  N/A			
19. KEY WORDS (Continue on reverse side if necessary and identify by block number)  Lightning, lightning protection, induced voltages.			
20. ABSTRACT (Continue on reverse side if necessary and identify by block number)  As a result of the survey performed at subject USAF sites, recommendations are made to decrease vulnerability to lightning which have been destroying communication equipment components.  M			

APPROVAL PAGE

This report has been reviewed and is approved for publication and distribution.

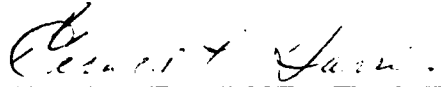

---

GERALD T. HARRIS  
1842 EEG/EEI  
Chief, Electronics/Base Systems Engineering Division

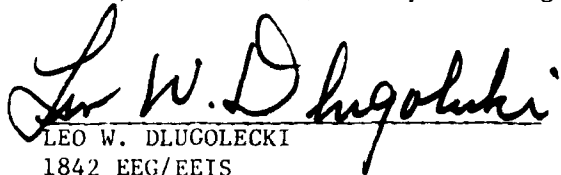

---

LEO W. DLUGOLECKI  
1842 EEG/EEIS  
Chief, Support Engineering Branch

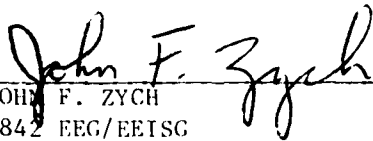

---

JOHN F. ZYCH  
1842 EEG/EEISC  
TAM, General Engineering, Author

TABLE OF CONTENTS

<u>Paragraph</u>		<u>Page</u>
SUMMARY		
1.0	INTRODUCTION	1
2.0	ANALYSIS	1
3.0	RECOMMENDATION	2

LIST OF ILLUSTRATIONS

<u>Figure</u>		<u>Page</u>
1	Existing Antenna Configuration on Control Tower Roof (Front View)	4
2	Existing Antenna Configuration on Control Tower Roof (Top View)	5
3	Existing Control Tower Ground System	6
4	Proposed Typical New Ground System	7
5	Recommended Lightning Protection System with FM Antenna Relocated	8
6	Recommended Lightning Protection System without FM Antenna Relocated	9
6A	Typical Details	10

LIST OF TABLES

<u>Table</u>		<u>Page</u>
1	Recommended List of Materials	11
Appendix A Tests and Measurements		A-1 thru A-4

Accession For	
NTIS	<input checked="" type="checkbox"/>
GRA&I	<input type="checkbox"/>
DTIC TAB	<input type="checkbox"/>
Unannounced	<input type="checkbox"/>
Justification	
By _____	
Distribution/	
Availability Codes	
Dist	Avail and/or
	Special
A	

## LIGHTNING PROBLEM AT BUILDING 1409 CONTROL TOWER, MAXWELL AFB, AL

### SUMMARY

As a result of a site survey performed at Bldg 1409, Control Tower, Maxwell AFB AL, recommendations are made to decrease the vulnerability of the facility and the existing electronic equipment housed inside to lightning which has been destroying electronic equipment and creating a safety hazard to control tower controllers and maintenance personnel.

1.0 INTRODUCTION. HQ AU/DC requested technical assistance in determining action to take to improve lightning protection at Facility 2201, Bldg 1049, at Maxwell AFB AL.

1.1 Mr. John Zych was assigned this task and on 27 and 28 Jan 81 performed a site survey at the subject facility.

1.2 This report provides findings and recommendations based on the site survey performed.

2.0 ANALYSIS.

2.1 The lightning problem at Bldg 1409, Control Tower at Maxwell AFB AL was analyzed by having discussions with site and maintenance personnel as to the present and past problems and damage done as a result of recent lightning strikes, and an on-site physical inspection of the electronic equipment and the facility. Also, the Base Civil Engineer was contacted for drawings and discussions on the existing grounding systems.

2.2 Based on the discussions and facility inspection, the lightning problems can be attributed to the control tower and its protruding antenna masts being the highest objects in the immediate vicinity. Lightning is being attracted by these antenna masts. Once attracted to the facility, the lightning is entering the facility by means of the existing antenna cables. Lightning either through the existing electronic equipment or the existing power system, seeks ground. This path may be through existing power cables, conduits, fire alarm cables, etc. Discussion with radio maintenance disclosed that radio damage occurred to circuits connected to antenna leads. This implies that lightning followed the antenna cable to the radio equipment and then ground.

2.3 The existing grounding/lightning system for the facility is inadequate. The existing system consists of one stranded #4/0 AWG cable leading from the existing grounding system up to the roof of the control tower. Figures 2 and 3 depict the existing grounding system. On the way up this cable deviates from a straight path and forms a "U" around a sliding door (fifth floor). Existing splices in this cable were also full of paint and appeared to have never been cleaned or tightened. Any new lightning down conductors should be continuous and direct with as few bends as possible. The existing lightning protection codes, e.g., UL 96A and NFPA No. 78 state that for facilities over 75 feet high a minimum # 2/0 AWG stranded copper conductor should be used as the down conductor. Any new conductors provided should meet this requirement.

2.4 The FM non-TAC radio antenna is the highest protrusion on the roof of the control tower (see Figure 1) and is acting as an air terminal attracting lightning to the tower. Discussion with maintenance personnel disclosed that the FM radio has had electronic circuit damage attributed to lightning. Other electronic equipment (located adjacent to the FM radio) also experienced component damage which has been attributed to lightning.

### 3.0 RECOMMENDATIONS.

3.1 Recommend that action be taken to relocate the existing FM non-TAC radio antenna to another facility or location at a lower position (e.g., 5th floor railing). The aluminum mast of this antenna extends above the control tower roof and acts as an air terminal for the control tower and attracts lightning to the control tower (see Figures 1 and 2 for details.) If this antenna can be relocated to a lower position, a relatively simple lightning protection system can be implemented using the existing antenna masts.

3.2 An additional lightning protection system must be provided on the roof of the control tower. This system should be composed of air terminals mounted on existing antenna masts protruding above the existing antennas, two (2) down conductors (min # 2/0 AWG bare stranded cable), located on each side of tower, cables and air terminals interconnected to insure no difference of potential exists between the air terminals, and connections to the existing ground system at the base of tower. Figure 5 depicts the recommended lightning protection system. Recommend that a low resistance ground (minimum 10 ohms) measured IAW instructions in Appendix 1 also be provided. The existing ground system is composed of 4 ground rods interconnected with a # 4/0 AWG cable on each side of control tower. Figure 3 shows the location of the existing ground system. Since this ground is approximately 20 years old, recommend additional ground rods and interconnecting cabling be provided at the base of the control tower. See Figure 4 for typical proposed new grounding system. This recommended lightning protection system shall provide adequate protection to the facility and personnel working in the control tower. The lightning protection principle proposed in this scheme is called a "cone of protection" which is recommended by existing lightning protection codes. The "cone of protection" is terminology used to state that the facility and any protrusions will be protected from lightning as long as the air terminals, down conductor and a good ground system are provided for the facility. Any objects such as antennas, obstruction lights, vent pipes, etc., are protected as long as they fall under a cone formed between the top of an air terminal and the edges of facility at an angle of  $45^{\circ}$ . With two air terminals located at the existing antenna masts, all items on the roof of control tower including the antennas will fall under the "cone of protection" formed by the air terminals. If any new antennas are placed on top of control tower in the future, care must be taken to insure that it is placed within the "cone of protection" formed by the air terminals or lightning protection system be changed to accommodate the new antennas.

3.3 If the existing FM antenna cannot be removed or relocated, the lightning protection system required will be more complex. Figure 6 shows this recommended lightning protection system. This system is more complex in that one existing antenna mast (near existing UHF/VHF antennas) may be used for the location of one air terminal and the other air terminal will be added on a new pipe mast located on the existing safety railing. This air terminal must be located above the FM antenna to provide lightning protection for the FM antenna and existing UHF/VHF antennas. The "cone of protection" principle also applies in this situation and any changes in roof protrusions such as additional antennas should be checked to insure protection by air terminals.

3.4 Recommend lightning protection be provided on incoming communication cable. Existing cable has no lightning protection such as gas tubes, etc., on the cable as it enters the control tower. Consideration should be given to upgrading the lightning protection on all incoming cable(s).

3.5 Table 1 contains a recommended list of materials for use if the recommended actions are taken (as prescribed in paras 3.1 through 3.4) to implement the required lightning protection measures.

3.6 The installation of the lightning protection system may introduce some antenna pattern distortion of the existing VHF/UHF antennas. After installation of any lightning protection system, testing of VHF/UHF radios should be undertaken to insure that no appreciable interference has been caused by the installation. If any interference exists, the air terminals must be relocated to the farthest point on the roof from the existing antennas. This installation would be similar to the air terminal installation shown in Figure 6.

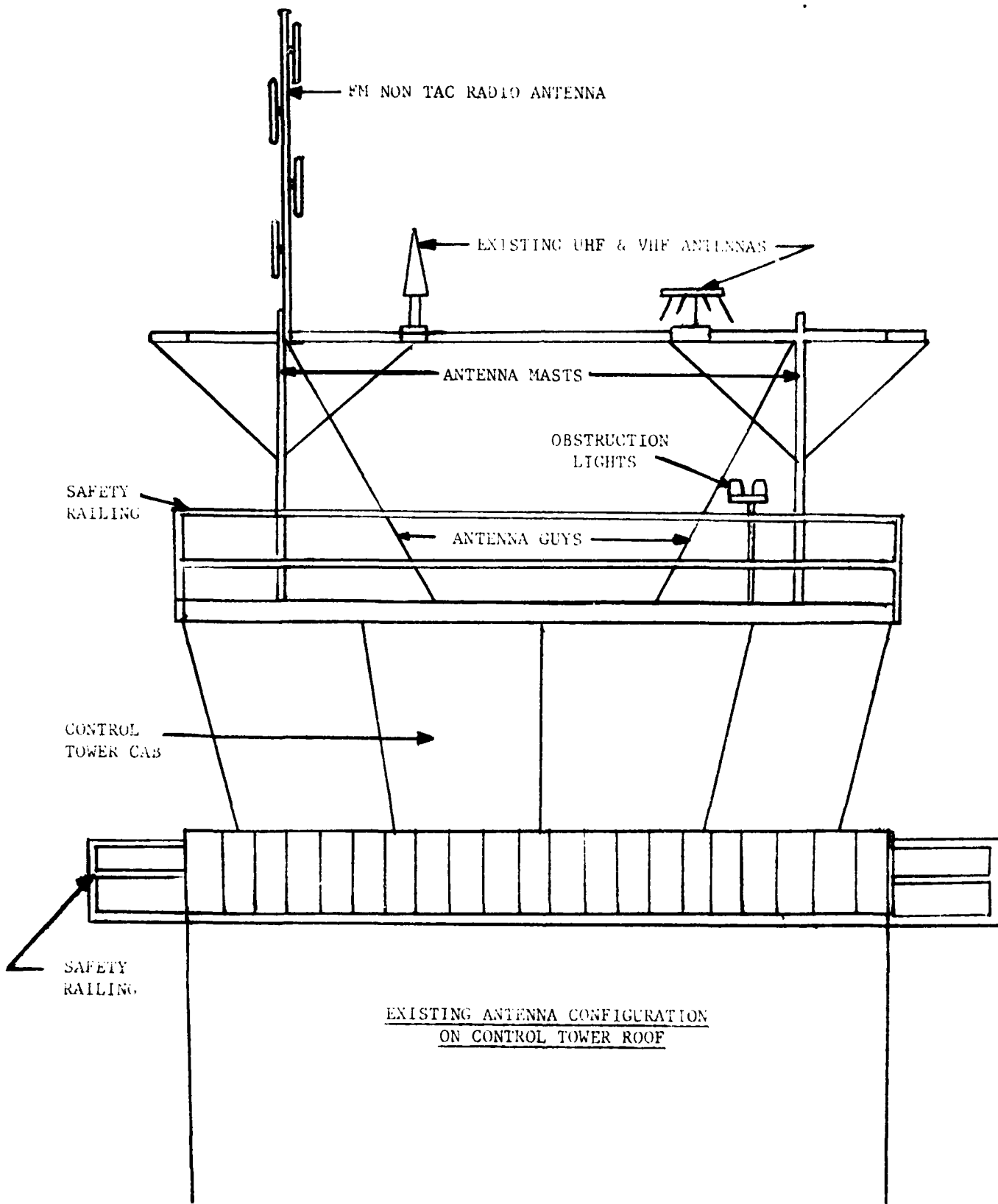

FRONT VIEW

Figure 1

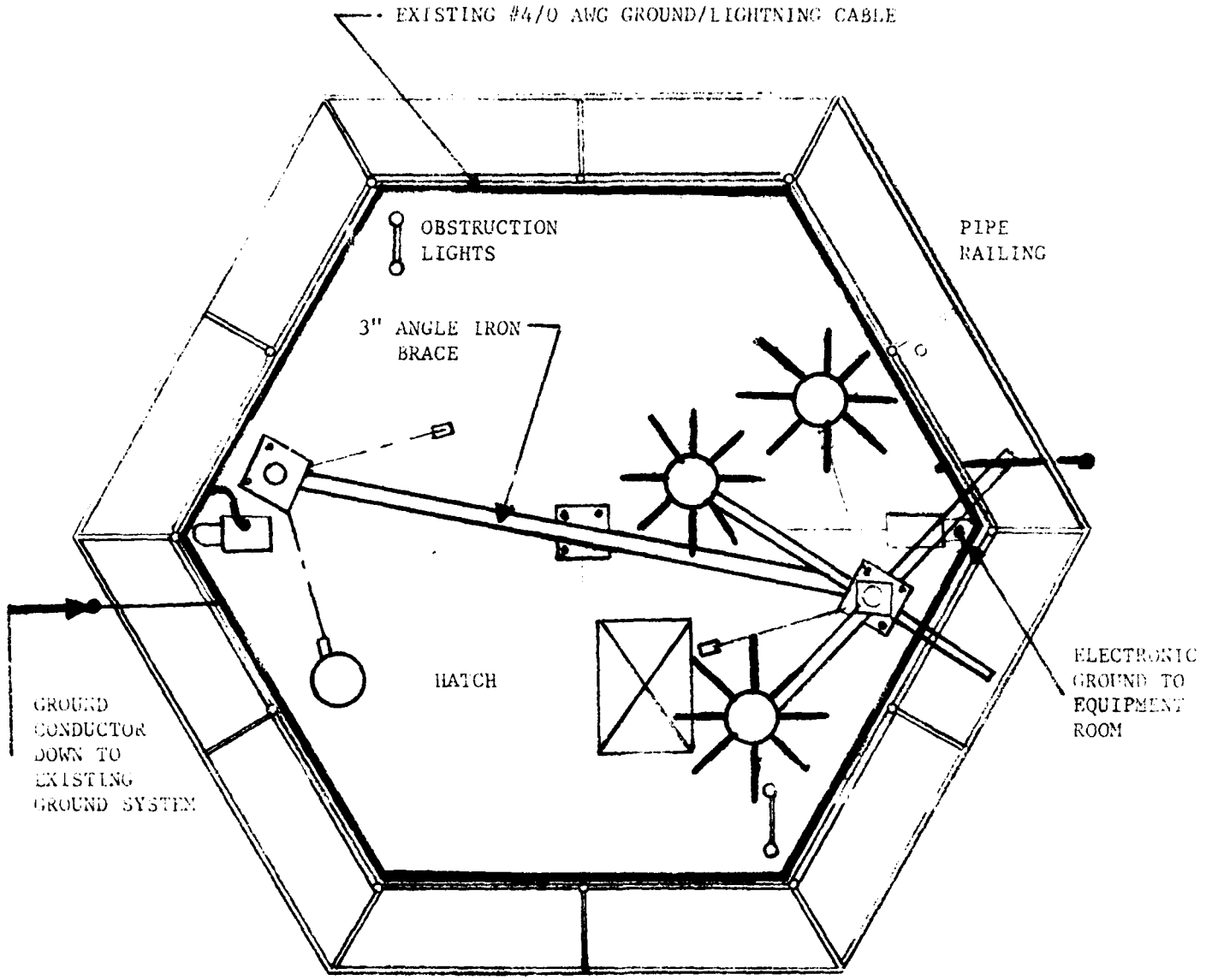

TOP VIEW

KEY

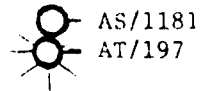

EXISTING CONTROL TOWER ANTENNA LAYOUT

Figure 2

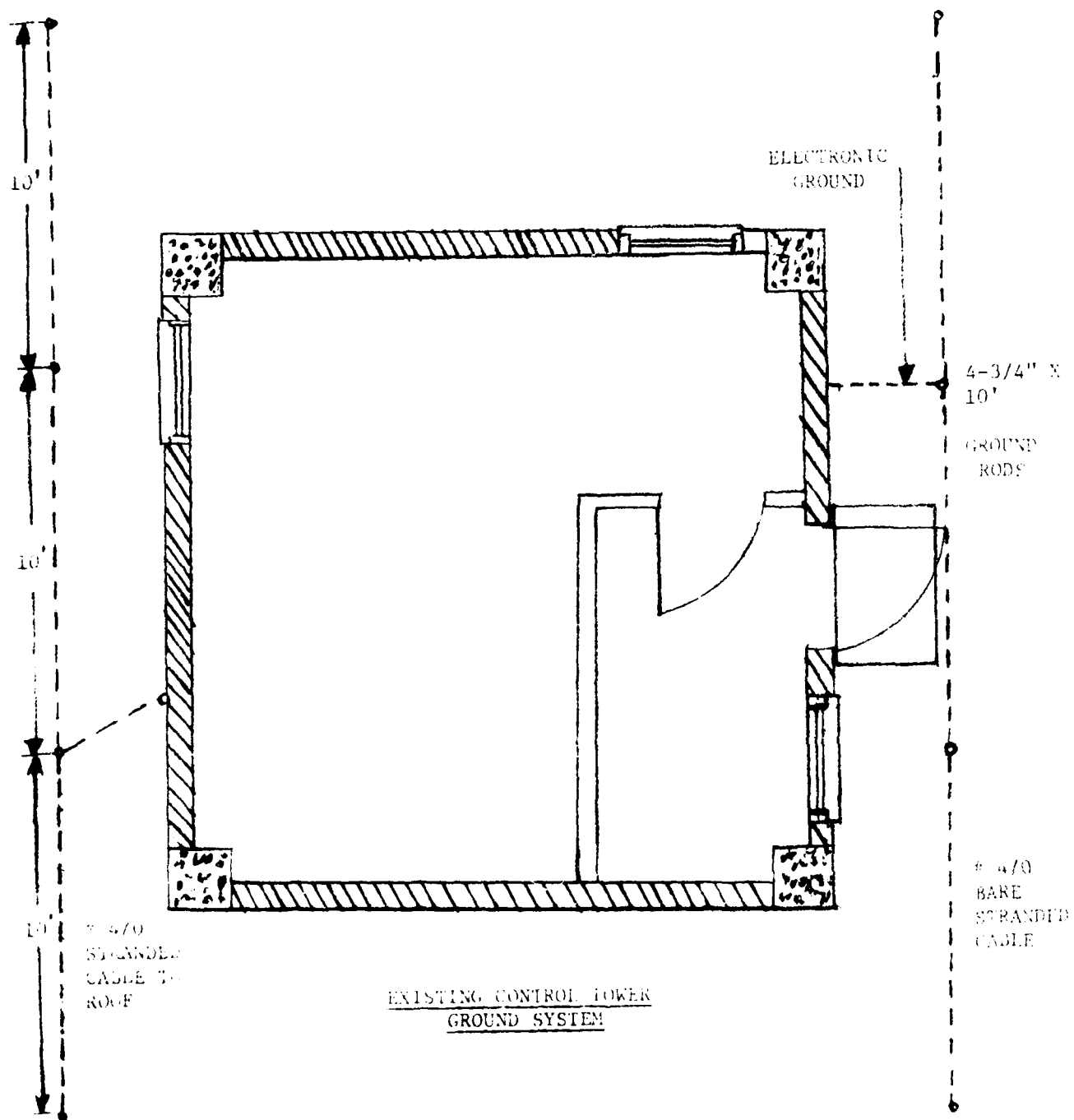
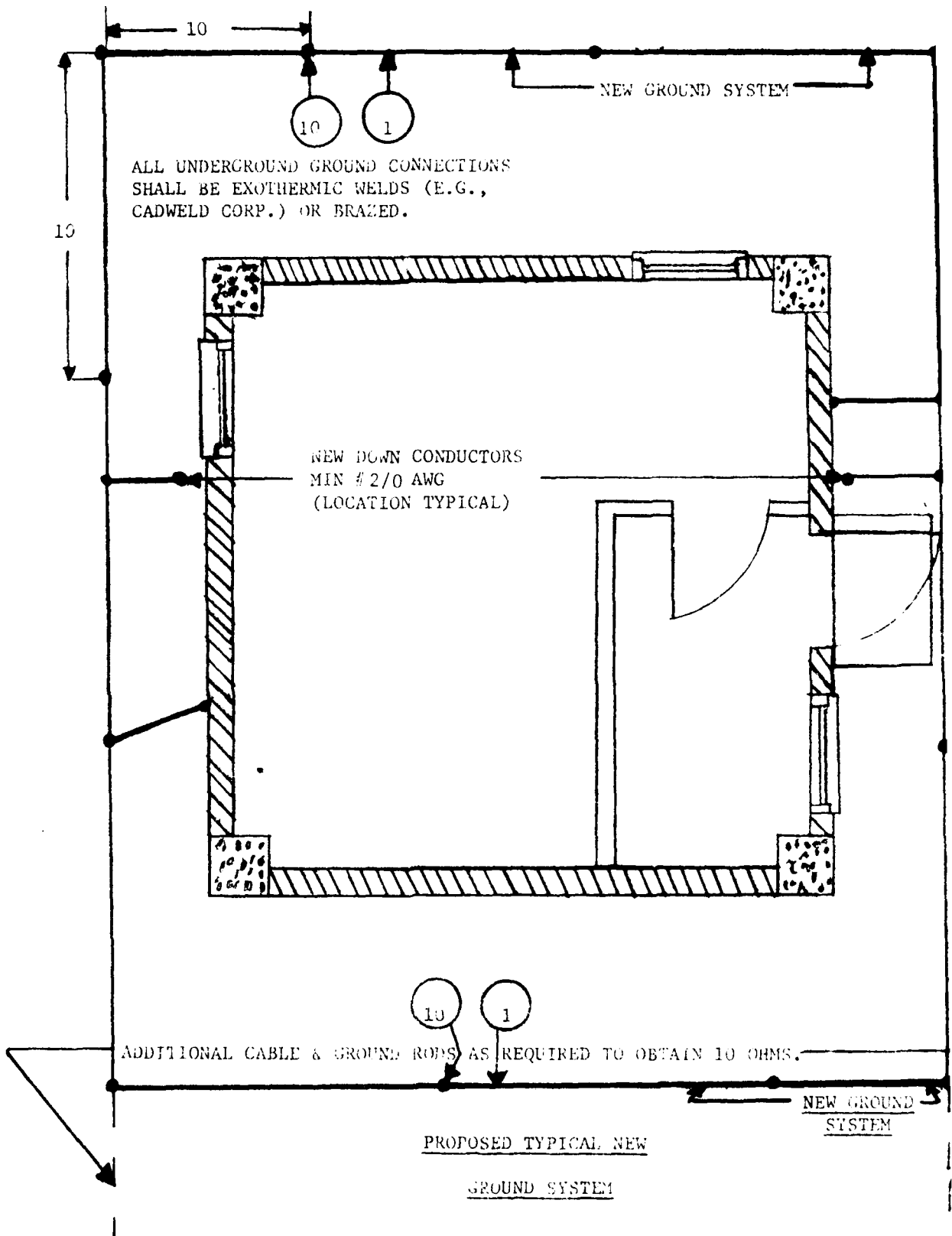

Figure 1



● Figure 4

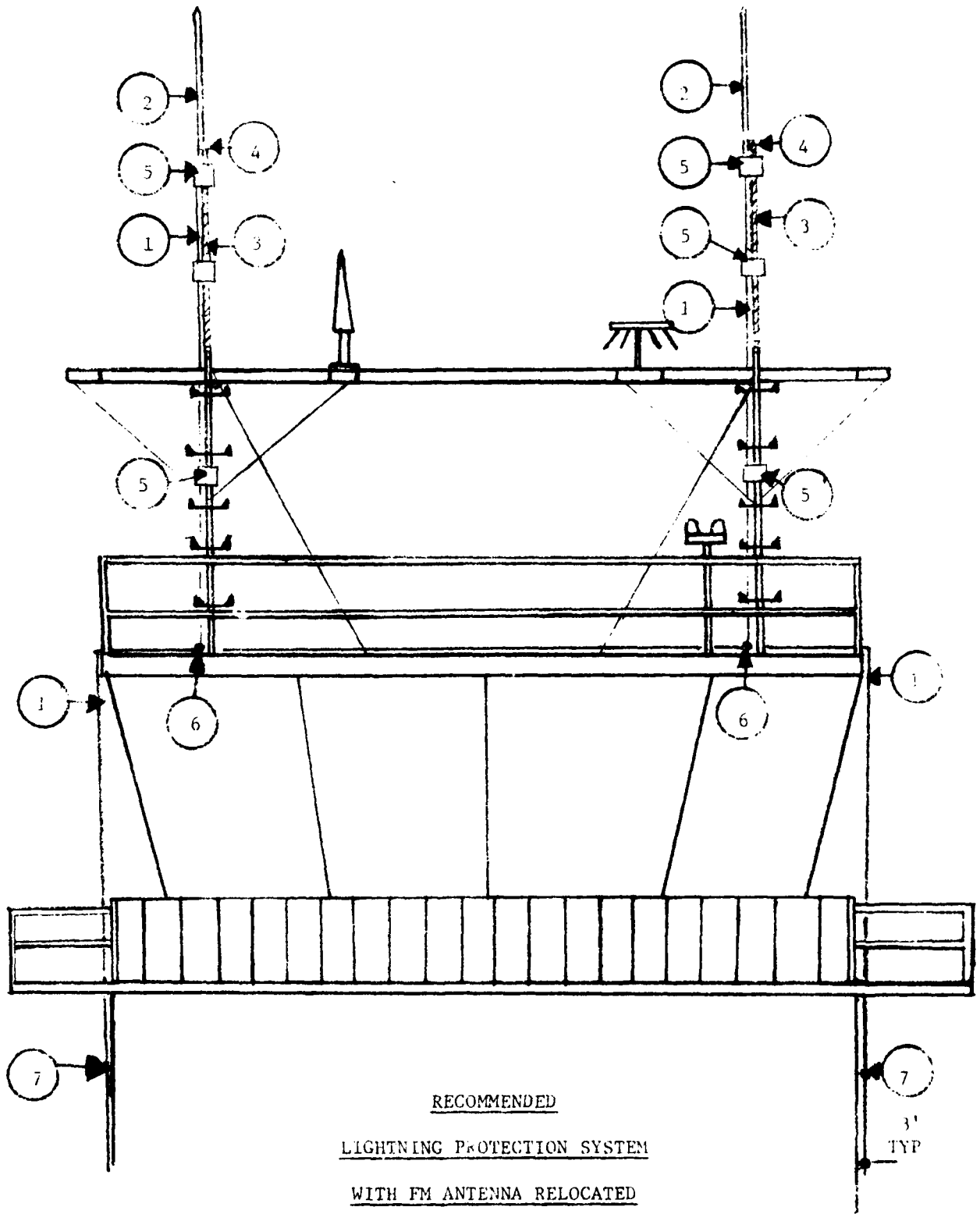

Figure 5

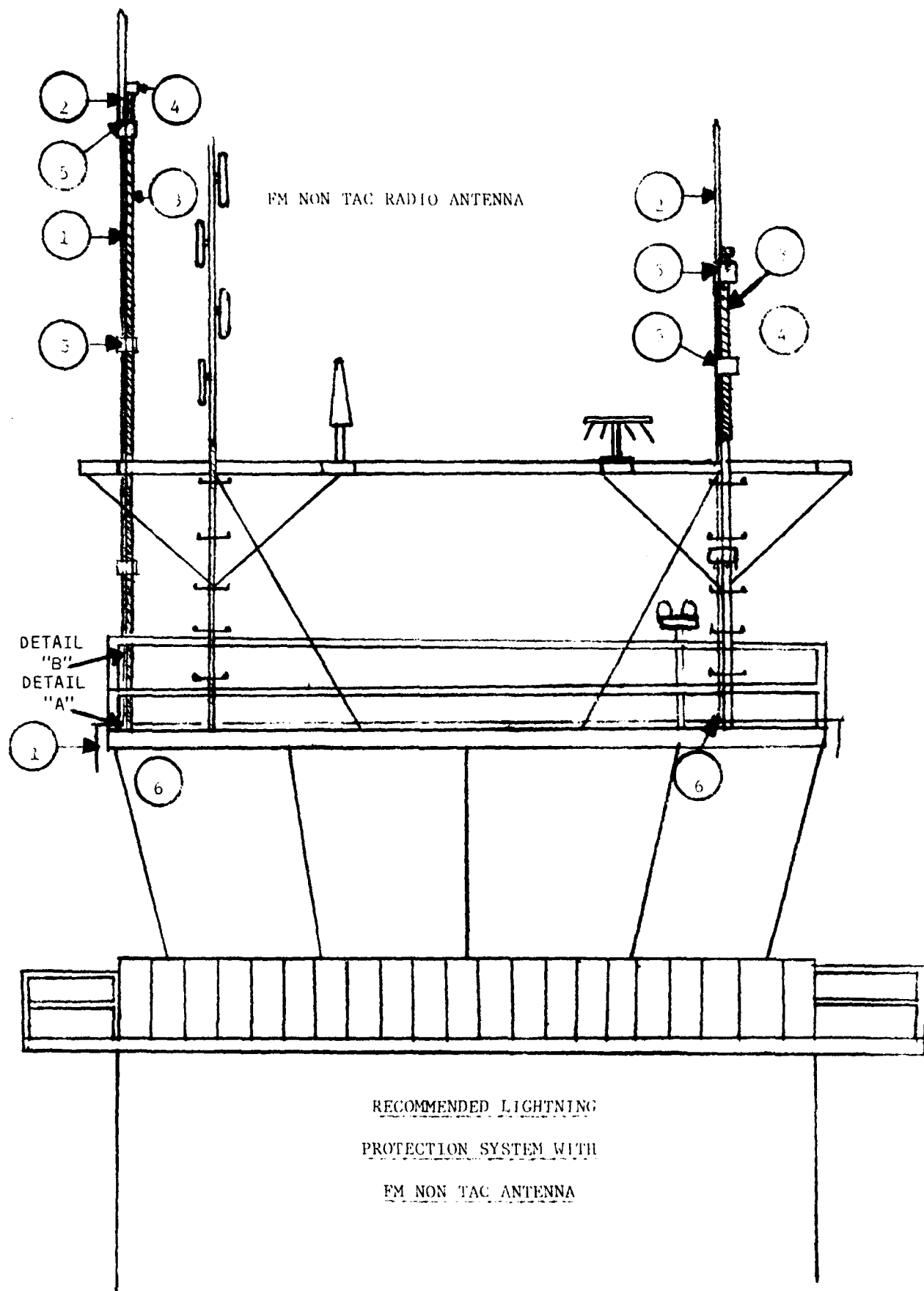
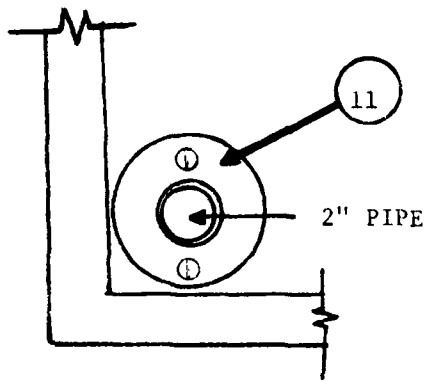
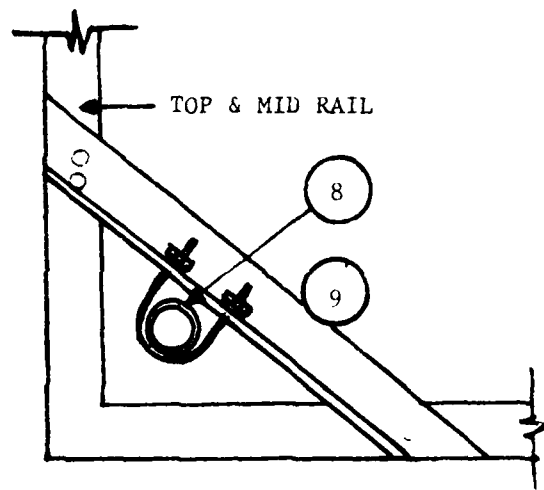

Figure 6

BOTTOM RAIL



DETAIL A



DETAIL B

Figure 6A

TABLE 1. RECOMMENDED LIST OF MATERIALS

<u>Find #</u>	<u>Description</u>	<u>Unit of Issue</u>	<u>Recommended Manufacturer or Equal</u>	<u>Manufacturer's Part #</u>	<u>Quantity Required</u>
1	BARE #2/0 AWG Copper Conductor	FT	Thompson Lightning Protection Company	506	300 FT
2	Air Terminal 5' x 1/2" Dia.	EA	Thompson Lightning Protection Company	689	2
3	2" Steel Pipe	Length	Local Purchase	None	* 2' - 6' long ** 1' - 6', 1 20'
4	2" Pipe Cap	EA	Local Purchase	None	2 FT
5	Pipe Clamp 1 1/2" - 2 1/2" Pipe	EA	Thompson Lightning Protection Company	240X	* 8 (TYP) ** 12 (TYP)
6	T Cable Clamp	EA	Thompson Lightning Protection Company	706	4
7	Cable Wall Fasteners (3' apart)	EA	Thompson Lightning Protection Company	441B or 735 (TY	As Required
8	U Bolt 2" Fasteners	EA	Thompson Lightning Protection Company	803	2
9	Angle Iron Typical 2 1/2" x 2 1/2"	Length	Local Purchase	None	As Required
10	Ground Rod, 3/4" x 10' long	EA	Local Purchase	None	As Required
11	Pipe Flange 2"	EA	Local Purchase	None	As Required

\* Quantity required with FM antenna relocated or removed.

\*\* Estimated quantity with FM antenna not relocated.

**APPENDIX A**  
**TESTS AND MEASUREMENTS**

**1. Earth Electrode Resistance-to-Ground Measurements**

a. Test equipment and tools needed for earth electrode resistance-to-ground measurements are listed below:

(1) Biddle null-balance earth tester, catalog No. 63241 (battery operated) or No. 63220 (hand cranked); Vibroground\* model 293 or 263 (model 293 is preferred, due to its wider range); or equivalent.

**NOTE**

The Vibroground or Biddle battery-operated tester must be checked for proper battery condition before and after testing. Weak batteries result in erroneous readings.

(2) Accessory kit of two 18-inch ground rods and three wire leads with clips in a canvas bag; Biddle catalog No. 63579, Vibroground test kit model #7105, or equivalent.

(3) Two additional ground rods, 4 feet long and 1/2-inch diameter. (Identified for testing as P2 and 62)

(4) 500 feet of wire, insulated, stranded, #12 to #6 AWG.

(5) 300 feet of wire, insulated stranded, #18 to #12 AWG (twisted pair, insulated, solid, #22 AWG is also acceptable for the potential (P2) lead).

(6) Two 50-A capacity battery clamps, insulated.

(7) Tape measure (100 feet).

(8) Small sledge hammer.

(9) Adjustable wrench, 1-inch to 1 1/2-inch jaw capacity.

**WARNING**

Always attach the safety bonding strap when opening or disconnecting primary grounding connections. The discharge of a fault voltage or current on the wiring at the disconnect point could cause serious burns, injury, or death without the safety bond in place.

b. The fall-of-potential earth resistance method is as follows: A ground rod, C2, is driven about 2 feet\* (C-1, earth electrode to be tested) into the earth at a considerable distance from C1 (table B-1). Both are connected to the null-balance earth tester; the lead from the electrode to be measured to the C1 terminal and the lead from C2 to the C2 terminal. A wire strap is connected between the C1 and P1 terminals. Cranking the

hand generator or pushing the operate button, which is part of the null-balance tester, sends current through the earth between the two electrodes. Rod P2, connected to the tester galvanometer and driven into the earth about 1 to 1 1/2 feet\* (C-1, earth electrode to be tested) at various points along a straight line between C1 and C2, is subjected to varying earth potentials. Adjusting the digital balancing resistances at each of these points for a center reading on the galvanometer gives corresponding resistance readings that may be plotted.

### WARNING

All methods of testing ground connections involve danger to life. Observe all cautions and warnings noted for the testing instrument. Avoid potential faults by utilizing all applicable protective means.

### NOTE

When testing the resistance of a single electrode, all connections must be removed prior to attaching test leads. When testing the entire earth electrode subsystem, all normal ground leads should be connected.

(1) If the test readings are plotted against the distance from C1, the resulting curve will show that the ground resistance between C1 and P2 increases to a certain point, levels off, and then increases again as C2 is approached if C2 is placed far enough from C1. The true resistance to earth at electrode C1 is the value at the leveled-off portion of the curve, before it is influenced by rod C2. This point will normally be reached about 62 percent of the distance from rod C1 and rod C2. If the curve does not level off, C2 must be placed at a significantly greater distance from C1.

(2) The direction of the C2 electrode from C1 has only a minor affect on the accuracy of the reading, so long as the area selected is free of other metal objects in the measurement area and the earth is reasonably homogeneous.

c. Certain precautions are required to ensure that accurate readings are made. The precautions discussed below will be observed when performing earth resistance measurements.

(1) When measuring ground resistances of less than about 1 ohm, contact resistances between the test leads and earth ground electrode become important. Bright, clean, metal-to-metal contact should be provided. This can be done easily by scraping away paint and oxidized layers with a knife at the test point.

(2) Again, when measuring low earth ground resistances, the leads used to connect C1 and C2 to the test meter should have low resistance compared to the resistance to be measured; less than 1/10 for about 10 percent accuracy. Lead resistance causes a higher reading than normal. Wire sizes from #12 AWG for the C1 lead and #6 AWG for the generally longer C2 lead are recommended for general use for distances between C1 and C2 up to 1,000 feet. The P2 lead resistance does not affect the reading at balance. Field or cross-connect wire is suitable.

(3) Ground conductors, metal pipes, lead-covered telephone cables, metal fencing, and other metallic objects in the ground in the test area short-circuit a portion of the ground and tend to produce lower readings. When the fall-of-potential method cannot be used, the comparison method can be resorted to in most cases. For a comparison electrode, an extensive, metallic, cold water-pipe network is useful. Such a network can have very low resistance - on the order of 0.5 to 2 ohms in soil of good-to-average

conductivity. When a water-pipe network is used as a reference electrode, all other ground wire connections to the network in the same building must be disconnected. A temporary earth ground can be provided for the disconnected facility. The point of connection to the water pipe should be as close to the point of entry into the building as possible. Joints in the pipe increase the resistance substantially.

d. The following safety precautions must be observed when performing earth resistance measurements:

(1) Outside measurements should not be conducted when the possibility of lightning exists.

(2) Leads to grounding electrodes should be treated as though a voltage could exist between the test leads and any point on the station ground network. Under no circumstances should the two hands or other sensitive parts of the body be allowed to complete the circuit between points of possible high potential difference.

(3) The wearing of rubber gloves is recommended as a precaution against accidental high potential from the test meter when changing rod locations.

\* Registered Trademark

\*\*The distance the rod is driven into the earth does not materially affect the accuracy of the reading, so long as good contact is obtained and the earth is reasonably homogeneous in that spot.

Table B-1. Guide to Approximate Location of Potential Reference Probe, P2, and Current Reference Probe, C2

Maximum dimension of earth ground electrode (C1) to be Measured* (feet)	Distance to P2 (feet)	Distance to C2 (feet)
2	40	70
4	60	100
8	90	140
16	125	200
40	200	320
80	280	450
140	365	590
200	440	710

\*For example, the diagonal across an area surrounded by an earthed metal fence or a rectangular ring ground around a building or tower.

Distribution Page

AFCS/EPE	2
AFCS/DEO	1
SCA/EPE	3
AU/DCS	2
1973 CS/CC	2
1842 EEG/EEISG	2
1842 EEG/EEISD/TIC	2

END

DATE  
FILMED

5 - 8 - 1

DTIC