

AD-A097 780

GANNETT FLEMING CORDDRY AND CARPENTER INC HARRISBURG PA F/G 13/13
NATIONAL DAM INSPECTION PROGRAM, CRYSTAL LAKE DAM (NDI ID NUMBE--ETC(U)
JAN 81 DACW31-81-C-0018

UNCLASSIFIED

NL

100 J
an
2075

END
DATE
FILMED
5-81
DTIC

~~SECRET~~

DELAWARE RIVER BASIN
LEHIGH RIVER, WAYNE COUNTY

PENNSYLVANIA

CRYSTAL LAKE DAM

NDI ID NO. PA-00096
DER ID NO. 64-6

POCONO SPRINGS ESTATES, INC.

PHASE I INSPECTION REPORT
NATIONAL DAM INSPECTION PROGRAM

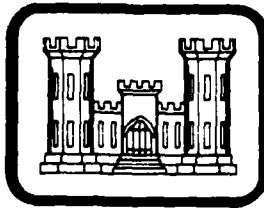

Prepared by
GANNETT FLEMING CORDDRY AND CARPENTER, INC.
Consulting Engineers
Harrisburg, Pennsylvania 17105

For
DEPARTMENT OF THE ARMY
Baltimore District, Corps of Engineers
Baltimore, Maryland 21203

JANUARY 1981

AD A 097780

①
K

DTIC FILE COPY

Original contains color plates. All DTIC reproductions will be in black and white.

DTIC
COLLECTED
APR 15 1981

DISTRIBUTION STATEMENT A
Approved for public release;
Distribution Unlimited

81 4 6 08
81 4 6 08
81 4 6 08

13 DACW31-81-C-0018

1

DELAWARE RIVER BASIN
LEHIGH RIVER, WAYNE COUNTY
PENNSYLVANIA

6 National Dam Insp. Program

CRYSTAL LAKE DAM

(NDI ID ^{Number} PA-00096
DER ID, ^{Number} 64-6)

~~POCONO SPRINGS ESTATES, INC.~~

Delaware River Basin, Lehigh River
Wayne County, Pennsylvania

PHASE I INSPECTION REPORT
NATIONAL DAM INSPECTION PROGRAM

DTIC
APR 15 1981
C

12/84

Prepared by
GANNETT FLEMING CORDDRY AND CARPENTER, INC.
Consulting Engineers
P.O. Box 1963
Harrisburg, Pennsylvania 17105

For
DEPARTMENT OF THE ARMY
Baltimore District, Corps of Engineers
Baltimore, Maryland 21203

11 JAN 1981

DISTRIBUTION STATEMENT A
Approved for public release
Distribution Unlimited

411004

PREFACE

This report is prepared under guidance contained in Recommended Guidelines for Safety Inspection of Dams, for Phase I Investigations. Copies of these guidelines may be obtained from the Office of Chief of Engineers, Washington, D.C. 20314. The purpose of a Phase I Investigation is to identify expeditiously those dams which may pose hazards to human life or property. The assessment of the general condition of the dam is based upon available data and visual inspections. Detailed investigations, and analyses involving topographic mapping, subsurface investigations, testing, and detailed computational evaluations are beyond the scope of a Phase I Investigation; however, the investigation is intended to identify any need for such studies.

In reviewing this report, it should be realized that the reported condition of the dam is based on observations of field conditions at the time of inspection along with data available to the inspection team. In cases where the reservoir was lowered or drained prior to inspection, such action, while improving the stability and safety of the dam, removes the normal load on the structure and may obscure certain conditions which might otherwise be detectable if inspected under the normal operating environment of the structure.

It is important to note that the condition of a dam depends on numerous and constantly changing internal and external conditions, and is evolutionary in nature. It would be incorrect to assume that the present condition of the dam will continue to represent the condition of the dam at some point in the future. Only through continued care and inspection can there be any chance that unsafe conditions be detected.

Phase I inspections are not intended to provide detailed hydrologic and hydraulic analyses. In accordance with the established Guidelines, the spillway design flood is based on the estimated "Probable Maximum Flood" for the region (greatest reasonably possible storm runoff), or fractions thereof. The spillway design flood provides a measure of relative spillway capacity and serves as an aid in determining the need for more detailed hydrologic and hydraulic studies, considering the size of the dam, its general condition and the downstream damage potential.

Accession For	
NTIS GRA&I	<input type="checkbox"/>
DTIC TAB	<input type="checkbox"/>
Unannounced	<input type="checkbox"/>
Justification for	<i>from 500</i>
By	<i>file</i>
Distribution/	
Availability Codes	
Avail. and/or	
MSB	

A

CRYSTAL LAKE DAM
 NDI ID No. PA-00096; DER ID No. 64-6
 PHASE I INSPECTION REPORT
 NATIONAL DAM INSPECTION PROGRAM

CONTENTS

	<u>Description</u>	<u>Page</u>
	Brief Assessment of General Conditions and Recommended Action	111
SECTION 1	- Project Information	1
SECTION 2	- Engineering Data	5
SECTION 3	- Visual Inspection	7
SECTION 4	- Operational Procedures	9
SECTION 5	- Hydrology and Hydraulics	10
SECTION 6	- Structural Stability	12
SECTION 7	- Assessment, Recommendations, and Proposed Remedial Measures	14

APPENDICES

<u>Appendix</u>	<u>Title</u>
A	Checklist - Engineering Data.
B	Checklist - Visual Inspection.
C	Photographs.
D	Hydrology and Hydraulics.
E	Plates.
F	Geology.

PHASE I INSPECTION REPORT
NATIONAL DAM INSPECTION PROGRAM

BRIEF ASSESSMENT OF GENERAL CONDITION

AND

RECOMMENDED ACTION

Name of Dam: Crystal Lake Dam
NDI ID No. PA-00096
DER ID No. 64-6

Size: Small (13 feet high; 755 acre-feet)

Hazard Classification: Significant

Owner: Pocono Springs Estates, Inc.
Box 53
New Foundland, PA
Attn: Margie Nawrocki

State Located: Pennsylvania

County Located: Wayne

Stream: Lehigh River

Date of Inspection: 27 October 1980

Based on available records, visual inspection, calculations, and past operational performance, Crystal Lake Dam is judged to be in fair condition. Considering the size and hazard classification of the dam, the recommended SDF varies between the 100-year flood and the 1/2 PMF. The 1/2 PMF was, in this case, selected as the SDF. The spillway and reservoir, under existing conditions, will pass approximately 59 percent of the PMF before overtopping of the dam occurs. The spillway is rated as adequate.

No stability problems were observed at the dam. However, because of brush and small trees growing on the embankment, stability problems may have been obscured. There are a number of conditions at the dam which could develop into stability problems if allowed to go unchecked. Overall, maintenance of the dam has been inadequate.

The following studies and remedial measures, listed in approximate order of priority, are recommended to be undertaken by the Owner without delay:

(1) Remove all trees and brush growing on and near the embankment.

(2) Fill in low areas on the embankment to the design elevation (top of corewall) and fill animal burrows.

(3) Perform additional studies as required to determine the extent of deterioration of the concrete spillway and develop alternatives for correcting this situation. Take appropriate action to implement repairs.

(4) Take action as required to provide adequate erosion protection in the spillway discharge channel.

(5) The wet areas along the toe of the embankment and the erosion on the upstream slope should be visually monitored. If significant changes occur, take appropriate action as required.

All investigations, studies, designs, and inspection of construction should be performed by a professional engineer experienced in the design and construction of dams.

In addition, the Owner should institute the following operational and maintenance procedures:

(1) Develop a detailed emergency operation and warning system for the dam. When warnings of a major storm are given by the National Weather Service, the Owner should activate the emergency operation and warning system.

(2) During periods of unusually heavy rains, provide round-the-clock surveillance of the dam.

(3) Initiate an inspection program such that the dam is inspected on a regular basis. As presently required by the Commonwealth, the inspection program should include a formal annual inspection by a professional engineer experienced in the design and construction of dams. Utilize the inspection results to determine if remedial measures are necessary.

(4) Institute a maintenance program and develop a formal maintenance manual so that all features of the dam are properly maintained.

CRYSTAL LAKE DAM

Submitted by:

GANNETT FLEMING CORDDRY
AND CARPENTER, INC.



Frederick Futchko

FREDERICK FUTCHKO
Project Manager, Dam Section

Date: 9 February 1981

Approved by:

DEPARTMENT OF THE ARMY
BALTIMORE DISTRICT, CORPS OF
ENGINEERS

James W. Peck

JAMES W. PECK
Colonel, Corps of Engineers
District Engineer

Date: 4 MAR 81

CRYSTAL LAKE DAM



Overview

CRYSTAL LAKE DAM

NDI ID No. PA-00096; DER ID No. 64-6

PHASE I INSPECTION REPORT

NATIONAL DAM INSPECTION PROGRAM

SECTION 1

PROJECT INFORMATION

1.1 General.

a. Authority. The Dam Inspection Act, Public Law 92-367, authorized the Secretary of the Army, through the Corps of Engineers, to initiate a program of inspection of dams throughout the United States.

b. Purpose. The purpose of the inspection is to determine if the dam constitutes a hazard to human life or property.

1.2 Description of Project.

a. Dam and Appurtenances. Crystal Lake Dam is an earthfill dam with a concrete corewall, which extends from the crest of the dam to about three feet below the original ground line. The dam is 13 feet high and 870 feet long. Both the upstream and downstream slopes average 1V on 2H.

The concrete corewall varies in height and is two feet wide at the top. Drawings available show that the corewall was placed on a footing which is 2.5 to 3.0 feet wider than the base of the wall. The footing was designed to be 12 to 24 inches thick depending on location. The batter on the wall is shown to be two inches per foot on the upstream face and four inches per foot on the downstream face.

The spillway is a concrete overflow structure located near the center of the embankment at the approximate location of the original stream channel. The spillway has a rectangular, concrete weir and it discharges into a stone-lined stilling basin.

The outlet works is located at the right side of the spillway. It consists of a drop inlet-type intake structure and a gated, 34-inch diameter, concrete encased, riveted steel outlet pipe. The gate is located in the intake structure at the upstream end of the pipe. The crest elevation of the drop inlet structure is the same as the crest elevation of the spillway. The outlet works can be used for lowering the reservoir.

b. Location. Crystal Lake Dam is located on the headwaters of the Lehigh River in Lehigh Township, Wayne County, Pennsylvania. The dam is shown on USGS Quadrangle, Sterling, Pennsylvania, at latitude N 41° 16.4' and longitude W 75° 25.3'. A location map is shown on Plate E-1.

c. Size Classification. Small (13 feet high, 755 acre-feet).

d. Hazard Classification. Downstream conditions indicate that a significant hazard classification is warranted for Crystal Lake Dam (Paragraphs 3.1e and 5.1c).

e. Ownership. Pocono Springs Estates, Inc., Box 53, New Foundland, PA, Attn: Margie Nawrocki.

f. Purpose of Dam. Recreation.

g. Design and Construction History. The construction of the existing structure began in 1915 and was not completed until 1926. The dam is situated approximately 100 feet downstream from an old timber-crib dam built circa 1890. Most of the concrete corewall and spillway were constructed in 1915 and 1916. In early 1917, construction was terminated because of financial difficulties experienced by the company undertaking the project. At that time none of the embankment work had been completed. The project then remained abandoned until mid 1926 when another owner acquired the property and continued construction of the dam. It was at that time that the crest width of the upstream embankment portion of the dam was changed to four feet instead of the twelve feet specified in the original plans. The dam, except for the riprap on the upstream slope, was completed 27 November 1926. The riprap was placed sometime during the spring of 1927. Sometime following completion of the dam, earthfill was placed on the downstream side of the concrete corewall. Although photographs taken in 1938 show the embankment on the right side of the spillway to be completed, no records documenting the construction of the remainder of the embankment are available. A review of correspondence concerning the dam indicates that it may have been added sometime between 1948 and 1965.

In June 1967, the dam was inspected by the Commonwealth and found to be in poor condition. The report stated "the abutment walls have collapsed on the one side and the water is running around the back of the wall." Subsequent to that report, in the spring and summer of 1968 the spillway and outlet works were reconstructed. The existing spillway, however, is slightly different from that shown on the design plans. It is unknown whether this change was made during or sometime following the reconstruction. No other known modifications were made to the dam until 1977 when the spillway was resurfaced with shotcrete.

h. Normal Operational Procedure. The reservoir pool is maintained at the spillway crest level with excess inflows discharging over the spillway. Although it is seldom used, the outlet works can be used to draw down the reservoir. The intake structure, however, is accessible only by boat.

1.3 Pertinent Data.

a.	<u>Drainage Area.</u> (square miles)	0.77
b.	<u>Discharge at Damsite</u> (cfs)	
	Maximum known flood	Unknown
	Outlet works at maximum pool elevation	117
	Spillway capacity at maximum pool elevation	315
c.	<u>Elevation.</u> (feet above msl.)	
	Top of dam	2058.4
	Maximum pool	2058.4
	Normal pool (spillway crest)	2055.9
	Upstream invert outlet works	2055.9
	Downstream invert outlet works	2046.0
	Streambed at toe of dam	2045.4
d.	<u>Reservoir Length.</u> (miles)	
	Normal pool	0.54
	Maximum pool	0.55
e.	<u>Storage.</u> (acre-feet)	
	Normal pool	399
	Maximum pool	755
f.	<u>Reservoir Surface.</u> (acres)	
	Normal pool	133
	Maximum pool	152
g.	<u>Dam.</u>	
	<u>Type</u>	Earthfill with concrete corewall.
	<u>Length</u> (feet-including spillway)	870
	<u>Height</u> (feet)	13
	<u>Top Width</u> (feet)	6

g.	<u>Dam.</u> (Cont'd.)	
	<u>Side Slopes</u> Upstream and Downstream	Vary; average is about 1V on 2H.
	<u>Zoning</u>	None
	<u>Cut-off</u>	Corewall extends 3 feet below original ground surface.
	<u>Grout Curtain</u>	None
h.	<u>Diversion and Regulating Tunnel.</u>	None
i.	<u>Spillway.</u>	
	<u>Type</u>	Rectangular, concrete broad-crested weir with stone-lined stilling basin.
	<u>Length of Weir</u> (feet)	29.5
	<u>Crest Elevation</u> (feet above msl.)	2055.9
	<u>Upstream Channel</u>	Reservoir
	<u>Downstream Channel</u>	Natural stream.
j.	<u>Regulating Outlets.</u>	Drop inlet - type intake structure with 34-inch dia. gated, steel outlet pipe; crest elevation of drop inlet at 2055.9 ft.

SECTION 2
ENGINEERING DATA

2.1 Design.

a. Data Available. Design information for Crystal Lake Dam includes:

(1) Original design plans prepared October 1914 and revised November 1914.

(2) Design plans for the spillway and outlet works modifications prepared December 1967.

No design calculations are available.

b. Design Features. The project is described in Paragraph 1.2a. The various features of the dam are shown on the photographs in Appendix C and on Plates E-2 through E-6. A profile and typical cross-section of the dam are shown in Appendix B.

c. Design Considerations. Review of the design plans indicates that the project was designed reasonably well considering the state-of-the-art of dam design circa 1914.

2.2 Construction.

a. Data Available. The available data includes detailed construction progress reports and construction photographs submitted to the Commonwealth as well as reports prepared by the Commonwealth concerning conditions that arose during construction.

b. Construction Considerations. The available information is adequate to make a reasonable assessment of the dam.

2.3 Operation. There are no formal records of operation. Records of inspections performed by the Commonwealth are available for the period from 1927 to 1967. The inspection reports indicate that some deficiencies have existed since the dam was constructed. A summary of these inspection reports is included in Appendix A.

2.4 Evaluation.

a. Availability. Engineering data were provided by the Bureau of Dams and Waterway Management, Department of Environmental Resources, Commonwealth of Pennsylvania (PennDER). The Owner's representative was available for information during the visual inspection.

b. Adequacy. The type and amount of available design and other engineering data are generally adequate. The assessment of the dam is based on the combination of available data, visual inspection, performance history, and hydrologic and hydraulic assumptions.

c. Validity. There is no reason to question the validity of the available data.

SECTION 3

VISUAL INSPECTION

3.1 Findings.

a. General. The overall appearance of the dam and appurtenant structures is fair. Noteworthy deficiencies observed are described in the following paragraphs. The complete visual inspection checklist and sketch of the dam are presented in Appendix B. A profile of the top of the dam and a typical cross-section are also included in Appendix B. On the day of the inspection, the reservoir pool was approximately 0.4 foot below the spillway crest.

b. Embankment. The toe of the dam and entire embankment are covered with brush and small trees, up to one inch in diameter, obscuring the slopes from view and making a visual inspection difficult. Accordingly, some deficiencies may have gone unnoticed. The embankment slopes are irregular and do not appear to have been constructed to any particular design template. Settlement of the embankment was observed on both sides of the spillway and adjacent to the corewall along the entire length of the dam. These low areas vary in depth from only a few inches to nearly three feet. Erosion all along the upstream slope was observed at, or near, the normal pool level which has resulted in a nearly vertical two-foot drop in the slope. It is reported that riprap was placed on the slope during construction, although it was somewhat sparse in many places. There is very little riprap now remaining on the upstream slope.

Standing water was observed along a 150-foot section of the toe of the dam just to the left of the spillway. No evidence was observed to indicate that the water was the result of seepage through the dam, as opposed to surface runoff from the gravel road along the downstream toe of the dam. The Owner's representative indicated, however, that the standing water is a year-round condition which indicates that it may be caused by seepage. In any event, the problem is considered minor at this time. The area at the toe of the dam, to the right of the spillway, was also wet. Although the source of this condition is unknown, it may be caused by a lack of positive surface drainage in this area.

Several burrowing animal holes were observed on the downstream slope to the left of the spillway.

c. Appurtenant Structures. The concrete spillway and a portion of the corewall adjacent to the spillway were resurfaced with shotcrete in 1977. Tapping on the shotcrete surface of the spillway training walls and corewall adjacent to the spillway produces a hollow sound which indicates that the shotcrete is not

SECTION 3

VISUAL INSPECTION

3.1 Findings.

a. General. The overall appearance of the dam and appurtenant structures is fair. Noteworthy deficiencies observed are described in the following paragraphs. The complete visual inspection checklist and sketch of the dam are presented in Appendix B. A profile of the top of the dam and a typical cross-section are also included in Appendix B. On the day of the inspection, the reservoir pool was approximately 0.4 foot below the spillway crest.

b. Embankment. The toe of the dam and entire embankment are covered with brush and small trees, up to one inch in diameter, obscuring the slopes from view and making a visual inspection difficult. Accordingly, some deficiencies may have gone unnoticed. The embankment slopes are irregular and do not appear to have been constructed to any particular design template. Settlement of the embankment was observed on both sides of the spillway and adjacent to the corewall along the entire length of the dam. These low areas vary in depth from only a few inches to nearly three feet. Erosion all along the upstream slope was observed at, or near, the normal pool level which has resulted in a nearly vertical two-foot drop in the slope. It is reported that riprap was placed on the slope during construction, although it was somewhat sparse in many places. There is very little riprap now remaining on the upstream slope.

Standing water was observed along a 150-foot section of the toe of the dam just to the left of the spillway. No evidence was observed to indicate that the water was the result of seepage through the dam, as opposed to surface runoff from the gravel road along the downstream toe of the dam. The Owner's representative indicated, however, that the standing water is a year-round condition which indicates that it may be caused by seepage. In any event, the problem is considered minor at this time. The area at the **downstream toe of the dam to the right of the spillway**, was also wet. Although the source of this condition is unknown, it may be caused by a lack of positive surface drainage in this area.

Several burrowing animal holes were observed on the downstream slope to the left of the spillway.

c. Appurtenant Structures. The concrete spillway and a portion of the corewall adjacent to the spillway were resurfaced with shotcrete in 1977. Tapping on the shotcrete surface of the spillway training walls and corewall adjacent to the spillway produces a hollow sound which indicates that the shotcrete is not

SECTION 4

OPERATIONAL PROCEDURES

4.1 Procedure. The reservoir is normally maintained at the level of the spillway crest with excess inflows discharging over the spillway and into the downstream channel. The outlet works gate is reportedly opened when the reservoir rises several inches above the spillway crest.

4.2 Maintenance of Dam. There are no established procedures for maintenance of the dam. Maintenance work has been kept to a minimum and has generally been performed on an unscheduled basis. The dam is checked daily by Pocono Springs Estate's patrolmen; however, no formal reports are maintained.

4.3 Maintenance of Operating Facilities. There is no established procedure for maintenance of the outlet works facilities. The gate is, reportedly, operated at least twice annually. The intake structure can be accessed only by boat.

4.4 Warning Systems in Effect. There is no emergency operation and warning system for the dam.

4.5 Evaluation of Operational Adequacy. Although some maintenance is performed, the current program is inadequate. Inspections are necessary to detect hazardous conditions at the dam. An emergency operation and warning system is necessary to reduce the risk of dam failure should adverse conditions develop and to prevent loss of life should the dam fail.

SECTION 5

HYDROLOGY AND HYDRAULICS

5.1 Evaluation of Features.

a. Design Data. There are no hydrologic or hydraulic design calculations available for Crystal Lake Dam. An evaluation of the original spillway design by the Commonwealth determined the spillway capacity to be 90 cubic feet per second (cfs) which was considered inadequate. They recommended that the spillway be redesigned to have a capacity of not less than 225 cfs. This requirement was based on 150 cfs per square mile of drainage area which was estimated at 1.5 square miles at that time. Based on current USGS topographic maps, the drainage area has been determined to be 0.77 square mile. The spillway was apparently redesigned and constructed in accordance with the recommendations of the Commonwealth.

b. Experience Data. It is reported that the maximum lake level above the spillway crest during the past three years was about two inches. No other rainfall or reservoir records are available.

c. Visual Observations.

(1) General. The visual inspection of Crystal Lake Dam which is described in Section 3 resulted in a number of observations relevant to hydrology and hydraulics.

(2) Embankment. Although the crest of the embankment has settled significantly, it has a relatively minor effect on the hydraulics of the structure. That is, the crest of the concrete corewall has remained at a constant elevation and determines the elevation of the floodpool which can be impounded. There is an area at the west end of the reservoir which is 0.5 foot lower than the crest of the corewall. This area, in effect, acts as an auxiliary spillway. Water discharged from this end of the lake flows over an asphalt roadway and into a natural stream channel which enters the Lehigh River 1.5 miles downstream. This area, referred to as "Canoe Harbor" (see page D-4, Appendix D), was mentioned in a report by the Commonwealth dated 20 July 1914. Evidently, a dike similar to and the same height as the dam was to be constructed across this low area. However, no mention was made of this dike in later correspondence, construction reports, or design plans. This feature, however, has little effect on the hydraulic adequacy of the structure as discussed in Paragraph 5.1d.

(3) Appurtenant Structures. According to the Owner's representative the spillway was resurfaced with shotcrete in 1977. There are a number of areas on the training walls where the shotcrete was not adequately bonded to the underlying concrete and has spalled. This is of concern since large spillway discharges could aggravate the condition resulting in possible structural failure of the spillway or portions of it. Further, there is very little erosion protection at the toe of the spillway weir, which is already partially undermined.

(4) Reservoir Area. As previously mentioned, the reservoir itself comprises about one-fourth of the watershed area. The watershed which is primarily forested has no other impoundments located within its boundaries. Landslides are not considered a problem in this area, and are, therefore, not expected to influence the reservoir storage capacity.

(5) Downstream Conditions. A failure of Crystal Lake Dam would probably cause flooding of one part-time residence located 1.5 miles downstream from the dam. Klondike Pond is located approximately three miles downstream from Crystal Lake. Lower Klondike Dam has been previously assessed as "significant" hazard. Therefore, a "significant" hazard classification was also assigned to Crystal Lake Dam.

d. Overtopping Potential.

(1) Spillway Design Flood. According to the criteria established by the Office of the Chief of Engineers (OCE), the Spillway Design Flood (SDF) for the size (small) and hazard potential (significant) of Crystal Lake Dam is between the 100-year flood and one-half of the Probable Maximum Flood (1/2 PMF). Because of the size of the impoundment and the possibility of loss of life downstream, the 1/2 PMF was selected as the SDF for Crystal Lake Dam. The watershed and reservoir were modelled with the U.S. Army Corps of Engineers' HEC-1DB computer program. A description of this computer program is included in Appendix D. The assessment of the hydrology and hydraulics is based on existing conditions, without consideration of the effects of future development.

(2) Summary of Results. Pertinent results are tabulated at the end of Appendix D. The analysis reveals that Crystal Lake Dam can pass about 57 percent of the PMF, neglecting outflows from the Canoe Harbor area, before overtopping of the dam occurs. If discharges over the low area at Canoe Harbor are included in the analysis, this figure increases to 59 percent of the PMF.

(3) Spillway Adequacy. The criteria used to evaluate the spillway adequacy of a dam are described in Appendix D. Since Crystal Lake Dam can pass its SDF, the spillway is rated as adequate.

SECTION 6

STRUCTURAL STABILITY

6.1 Evaluation of Structural Stability.

a. Visual Observations.

(1) General. The visual inspection of Crystal Lake Dam, which is described in Section 3, resulted in a number of observations relevant to structural stability. These observations are evaluated herein for the various features.

(2) Embankment. The entire embankment was covered with brush and small trees at the time of the inspection hindering visual observations of the embankment and possibly obscuring any structural deficiencies.

The settlement along the crest of the dam is probably the result of poor compaction during construction, rather than a structural failure, since it was observed during inspections as early as eight months following completion of the dam. It was also reported during a construction inspection by the Commonwealth that the embankment soil was too wet to permit adequate compaction. The inspection report also stated that a significant amount of settlement would occur if the compaction techniques were not improved. The low areas on both sides of the spillway may also be caused by improper compaction, possibly during reconstruction of the spillway in 1968. The erosion at the normal pool level on the upstream slope is not a serious problem at this time, but could develop into a hazard if it is allowed to continue unchecked. The wet area at the toe of the dam, burrowing animal holes, and deteriorated corewall are not, at this time, considered detrimental to the structural stability of the dam.

(3) Appurtenant Structures. The condition of the spillway concrete is of concern both structurally and hydraulically and has been discussed in Paragraph 5.1c(3). In addition, the absence of adequate erosion protection in the spillway discharge channel could lead to further undermining of the spillway and subsequent structural problems. The corroded steel outlet pipe is reportedly encased in concrete and is not considered to affect the structural integrity of the dam or spillway.

b. Design and Construction Data. No calculations of embankment stability are available. However, nothing in the design plans or construction correspondence indicates any concern for the stability of the structure.

c. Operating Records. There are no operating records maintained for Crystal Lake Dam and Reservoir. The operating procedures followed by the Owner do not indicate cause for concern relative to the structural integrity of the dam.

d. Post-construction Changes. The modifications listed previously do not appear to adversely affect the structural stability of the dam.

e. Seismic Stability. Crystal Lake Dam is located in Seismic Zone 1 where earthquake loadings are not considered to be significant for small dams with no readily apparent stability problems. Since no readily apparent stability problems were observed, the seismic stability of the dam is considered to be adequate.

SECTION 7
ASSESSMENT, RECOMMENDATIONS, AND
PROPOSED REMEDIAL MEASURES

7.1 Dam Assessment.

a. Safety.

(1) Based on available records, visual inspection, calculations, and past operational performance, Crystal Lake Dam is judged to be in fair condition. Based on the size and hazard classification of the dam, the recommended SDF varies between the 100-year flood and the 1/2 PMF. The 1/2 PMF was, in this case, selected as the SDF. The spillway and reservoir, under existing conditions, will pass approximately 59 percent of the PMF before overtopping of the dam occurs.

(2) No stability problems were observed at the dam. However, brush and small trees growing on the embankment may have obscured stability problems. There are a number of conditions at the dam which could develop into stability problems if allowed to go unchecked.

(3) Maintenance of the dam is inadequate.

(4) A summary of the features and observed deficiencies is listed below:

<u>Feature</u>	<u>Observed Deficiency</u>
Embankment	Settlement along concrete corewall and adjacent to spillway; deterioration of exposed corewall; brush and small trees; irregular downstream slope; erosion of upstream slope at normal pool level; standing water at toe to left of spillway; wet area at toe to right of spillway; animal burrows.
Spillway	Shotcrete surfacing cracked, loose, or spalled; inadequate erosion protection in discharge channel.
Outlet Works	Intake structure accessible only by boat; steel outlet pipe is corroded at exit.

b. Adequacy of Information. The information available is such that an assessment of the condition of the dam can be inferred from the combination of visual inspection, past performance, and computations performed as part of this study.

c. Urgency. The recommendations in Paragraph 7.2 should be implemented without delay.

d. Necessity for Further Investigations. In order to accomplish the remedial measures outlined in Paragraph 7.2, further investigations by the Owner will be required.

7.2 Recommendations and Remedial Measures.

a. The following studies and remedial measures, listed in approximate order of priority, are recommended to be undertaken by the Owner without delay:

(1) Remove all trees and brush growing on and near the embankment.

(2) Fill in low areas on the embankment to the design elevation (top of corewall) and fill animal burrows.

(3) Perform additional studies as required to determine the extent of deterioration of the concrete spillway and develop alternatives for correcting this situation. Take appropriate action to implement repairs.

(4) Take action as required to provide adequate erosion protection in the spillway discharge channel.

(5) The wet areas along the downstream toe of the embankment and the erosion on the upstream slope should be visually monitored. If significant changes occur, take appropriate action as required.

All investigations, studies, designs, and inspection of construction should be performed by a professional engineer experienced in the design and construction of dams.

b. In addition, the Owner should institute the following operational and maintenance procedures:

(1) Develop a detailed emergency operation and warning system for Crystal Lake Dam. When warnings of a major storm are given by the National Weather Service, the Owner should activate the emergency operation and warning system.

(2) During periods of unusually heavy rains, provide round-the-clock surveillance of the dam.

(3) Initiate an inspection program such that the dam is inspected on a regular basis. As presently required by the Commonwealth, the inspection program should include a formal annual inspection by a professional engineer experienced in the design and construction of dams. Utilize the inspection results to determine if remedial measures are necessary.

(4) Institute a maintenance program and develop a formal maintenance manual so that all features of the dam are properly maintained.

APPENDIX A
CHECKLIST - ENGINEERING DATA

CHECKLIST
 NAME OF DAM: Crystal Lake Dam

ENGINEERING DATA
 NDI ID NO.: PA-00096 DER ID NO.: 64-6

DESIGN, CONSTRUCTION, AND OPERATION
 PHASE I
 Sheet 1 of 4

ITEM	REMARKS
AS-BUILT DRAWINGS	Typical "as-built" cross-section shown on Plate E-4 (Appendix E)
REGIONAL VICINITY MAP	See Plate E-1
CONSTRUCTION HISTORY	Numerous construction reports are contained in the PENNDEE files.
TYPICAL SECTIONS OF DAM	See Appendix E (Plate E-4) and Appendix B.
OUTLETS: Plan Details Constraints Discharge Ratings	See Plates E-5 and E-6

ENGINEERING DATA

ITEM	REMARKS
RAINFALL/RESERVOIR RECORDS	None
DESIGN REPORTS	None
GEOLOGY REPORTS	see Appendix F
DESIGN COMPUTATIONS. Hydrology and Hydraulics Dam Stability Seepage Studies	None
MATERIALS INVESTIGATIONS: Boring Records Laboratory Field	Records of test pits along the centerline of the dam are contained in the Penn DEER files
POSTCONSTRUCTION SURVEYS OF DAM	None

ENGINEERING DATA

ITEM	REMARKS
BORROW SOURCES	Embankment material reportedly taken from reservoir area; exact location is unknown.
MONITORING SYSTEMS	None
MODIFICATIONS	Spillway and outlet works were reconstructed in 1968; plans are shown in Appendix E and in REMDER files.
HIGH POOL RECORDS	None
POSTCONSTRUCTION ENGINEERING STUDIES AND REPORTS	None
PRIOR ACCIDENTS OR FAILURE OF DAM: Description Reports	None reported.

ENGINEERING DATA

ITEM	REMARKS
<p>MAINTENANCE AND OPERATION RECORDS</p>	<p>No records maintained</p>
<p>SPELLWAY: Plan Sections Details</p>	<p>See Plates E-5 and E-6 (Appendix E)</p>
<p>OPERATING EQUIPMENT: Plans Details</p>	<p>See Plates E-5 and E-6</p>
<p>PREVIOUS INSPECTIONS Dates Deficiencies</p>	<p>June 22, 1927 - General appearance rough but satisfactory; seepage causes swampy condition along the downstream toe; embankment has settled 12-18 inches on the right side of the spillway; water line irregular; riprap thin; floating muck being removed and placed at toe of dam.</p>
	<p>June 6, 1930 - Upstream fill settled 15" below crest of core wall; several spots on downstream face of concrete wall which are deteriorating.</p>

ENGINEERING DATA

ITEM	REMARKS
<p>PREVIOUS INSPECTIONS (continued)</p>	<p><u>Oct 22, 1935</u> - Some disintegration of concrete wall; upstream fill settled 1-2 feet below crest of wall; slight deterioration of spillway concrete; seepage at toe of wall on right side of spillway.</p>
<p>Note: Numerous construction inspection reports are also contained in the PENN DEER files.</p>	<p><u>Sept. 07, 1938</u> - Upstream fill 1-2 feet below core wall; some disintegration of spillway concrete; small stream at disintegrated section of wall right of spillway; deep disintegration of right abutment on upstream side - two foot section is undermined at upstream end; some disintegration of left spillway abutment.</p>
	<p><u>June 24, 1948</u> - Downstream face of wall on right side of spillway is disintegrated and should be repaired; some leakage near spillway and left end of dam; embankment overgrown with brush.</p>
	<p><u>March 12, 1965</u> - Overall condition - fair; spillway concrete cracked and spalled; possible leakage at toe of dam.</p>
	<p><u>June 24, 1967</u> - Overall condition poor; spillway in very poor condition.</p>

APPENDIX B

CHECKLIST - VISUAL INSPECTION

CHECKLIST

VISUAL INSPECTION

PHASE I

Name of Dam: Crystal Lake Dam County: Wayne State: Pennsylvania
NDI ID No.: PA-00096 DER ID No.: 64-6
Type of Dam: Earthfill w/ concrete core Hazard Category: Significant
Date(s) Inspection: 27 October 1980 Weather: Sunny, Windy Temperature: 50°F

Pool Elevation at Time of Inspection: 2055.5 ft. msl/Tailwater at Time of Inspection: 2045.9 ft. msl

Inspection Personnel:

W.B. Bingham (GFCC) L. Fraberi (Pocasa)
R.E. Holderbaum (GFCC) Springs Estates, Inc.
D.R. Ebersole (GFCC) Part-time

R.E. Holderbaum Recorder

EMBANKMENT

Sheet 1 of 3

VISUAL EXAMINATION OF	OISERVATIONS	REMARKS OR RECOMMENDATIONS
SURFACE CRACKS	None observed.	
UNUSUAL MOVEMENT OR CRACKING AT OR BEYOND THE TOE	None observed.	
SLOUGHING OR EROSION: Embankment Slopes Abutment Slopes (Continued, sheet 3 of 3)	Upstream slope is eroded at normal pool level; see typical embankment section at end of Appendix B.	Mast of downstream slope was obscured by heavy brush; brush should be cleared periodically.
CREST ALIGNMENT: Vertical Horizontal	Vertical - top of earth section varies ~ 2 feet; corewall is uniform in elev. Horizontal - good	see top of dam profile at end of Appendix B.
RIPRAP FAILURES	No riprap; upstream slope is eroded at normal water level.	

EMBANKMENT

Sheet 2 of 3

VISUAL EXAMINATION OF	OBSERVATIONS	REMARKS OR RECOMMENDATIONS
JUNCTION OF EMBANKMENT WITH: Abutment Spillway Other Features	20-ft. section of embankment is 3 feet low on right side of spillway; embankment at left end of spillway is 2 feet low.	No problems observed at abutments; low areas should be restored to original grade.
ANY NOTICEABLE SEEPAGE	Standing water at toe from left edge of spillway to 150 feet left of spillway; wet areas at toe to right of spillway.	Water is reportedly observed year-round.
STAFF GAGE AND RECORDER	None	
DRAINS	None observed.	
COREWALL	Earth embankment is lower than concrete corewall; some places as much as three feet	Embankment should be restored to original grade. Top of corewall is deteriorated in some places.

EMBANKMENT
Sheet 3 of 3

VISUAL EXAMINATION OF	OBSERVATIONS	REMARKS OR RECOMMENDATIONS
SLoughING OR EROSION Downstream Slope	Slope is irregular; does not appear to have been constructed to any design template.	Embankment should be inspected after brush is removed.
ANIMAL BURROWS	Several animal burrows were observed on the downstream slope.	Should be backfilled.

OUTLET WORKS

Sheet 1 of 1

VISUAL EXAMINATION OF	OBSERVATIONS	REMARKS OR RECOMMENDATIONS
CRACKING AND SPALLING OF CONCRETE SURFACES IN OUTLET CONDUIT	steel outlet pipe is badly corroded at outlet end.	Pipe is reportedly encased in concrete.
INTAKE STRUCTURE	Submerged, except for top six inches. Top of structure is in good condition.	
OUTLET STRUCTURE	Pipe exits through toe of spillway.	See next page (UNGATED SPILLWAY)
OUTLET CHANNEL	Spillway discharge channel.	See next page (UNGATED SPILLWAY)
EMERGENCY GATE	Reportedly operated twice annually.	

UNGATED SPILLWAY

Sheet 1 of 1

VISUAL EXAMINATION OF	OBSERVATIONS	REMARKS OR RECOMMENDATIONS
CONCRETE WEIR	Crest is in good condition; Training walls and corewall adjacent to spillway resurfaced with shotcrete in 1977.	Downstream side of weir is cracked and partially undermined.
APPROACH CHANNEL	Lake - unobstructed.	
DISCHARGE CHANNEL	No adequate erosion protection; Three 24-inch CMP's under road at toe of dam.	Channel downstream from road is natural; overbanks are wooded or brush covered.
BRIDGE AND PIERS	None	
CONCRETE SURFACES	Most of spillway resurfaced in 1977; shotcrete is not bonded properly with original surface and has fallen off	in several places; further investigation of spillway is recommended.

INSTRUMENTATION

Sheet 1 of 1

VISUAL EXAMINATION OF	OBSERVATIONS	REMARKS OR RECOMMENDATIONS
MONUMENTATION/SURVEYS	<i>None</i>	
OBSERVATION WELLS	<i>None</i>	
WEIRS	<i>None</i>	
PIEZOMETERS	<i>None</i>	
OTHER		

RESERVOIR AND WATERSHED

Sheet 1 of 1

VISUAL EXAMINATION OF	OBSERVATIONS	REMARKS OR RECOMMENDATIONS
SLOPES	<i>Moderately sloping; wooded.</i>	
SEDIMENTATION	<i>Unknown.</i>	
WATERSHED DESCRIPTION	<i>Pocano Springs Estates development; mostly wooded.</i>	

DOWNSTREAM CHANNEL

Sheet 1 of 1

VISUAL EXAMINATION OF	OBSERVATIONS	REMARKS OR RECOMMENDATIONS
CONDITION: Obstructions Debris Other	No major obstructions; stream channel meanders through mildly sloping swamp land.	
SLOPES	Mild; overbanks are fairly wide and flat.	
APPROXIMATE NUMBER OF HOMES AND POPULATION	One part-time residence located 1.5 miles downstream; Klondike Dam located 3 miles downstream.	Lower Klondike Dam classified as significant hazard during recently completed Phase I insp.

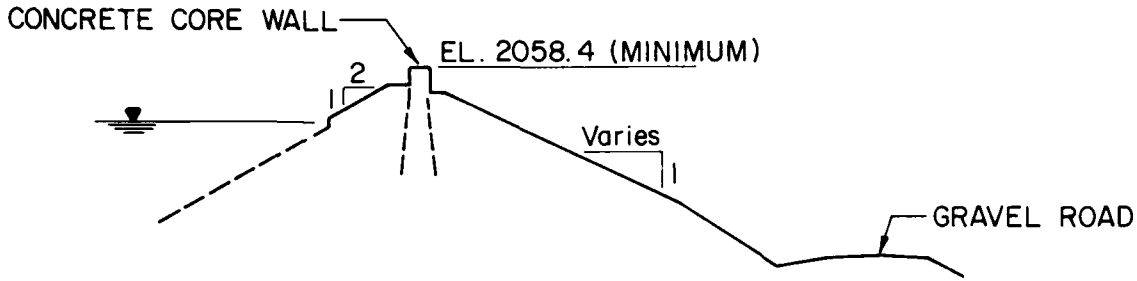

TYPICAL EMBANKMENT SECTION

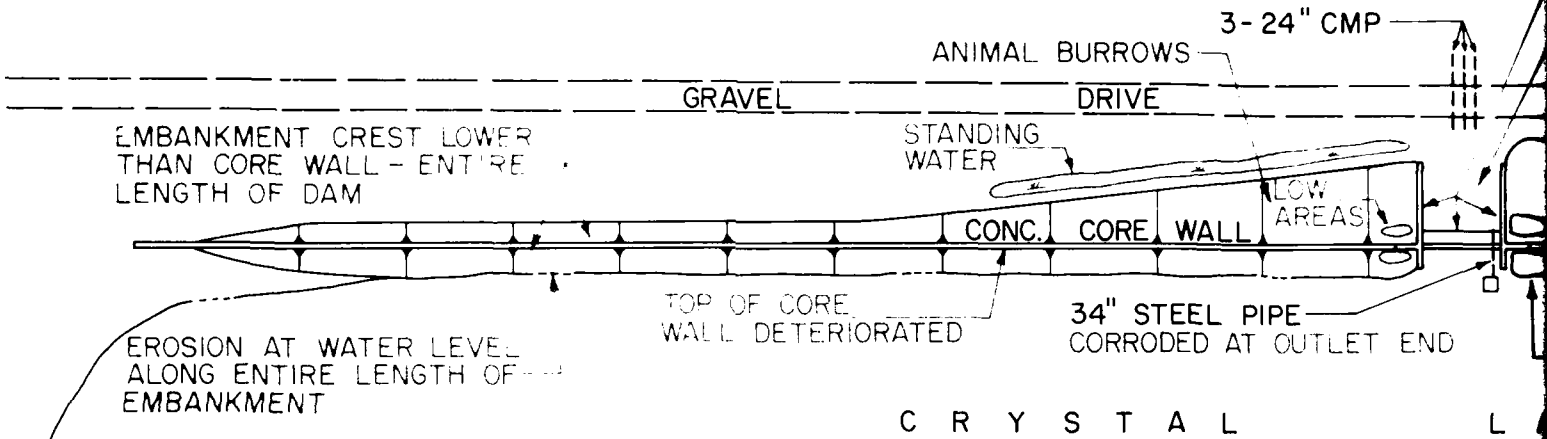

C R Y S T A L L

APPROXIMATE SCALE: 1 IN. = 60

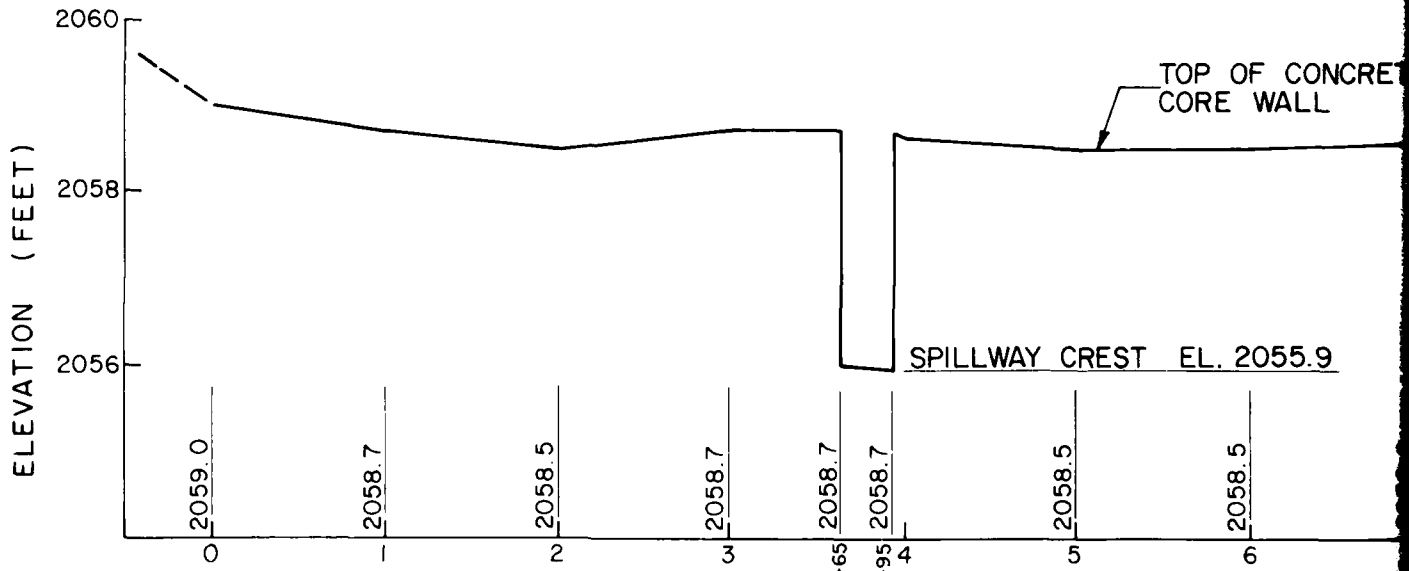

PROFILE-TOP OF DAM

SCALE: HORIZ: 1 IN. = 100 FT
 VERT: 1 IN. = 2 FT.

DATE OF INSPECTION: 27 OCTOBER 1980
 POOL ELEVATION: 2055 5 FEET

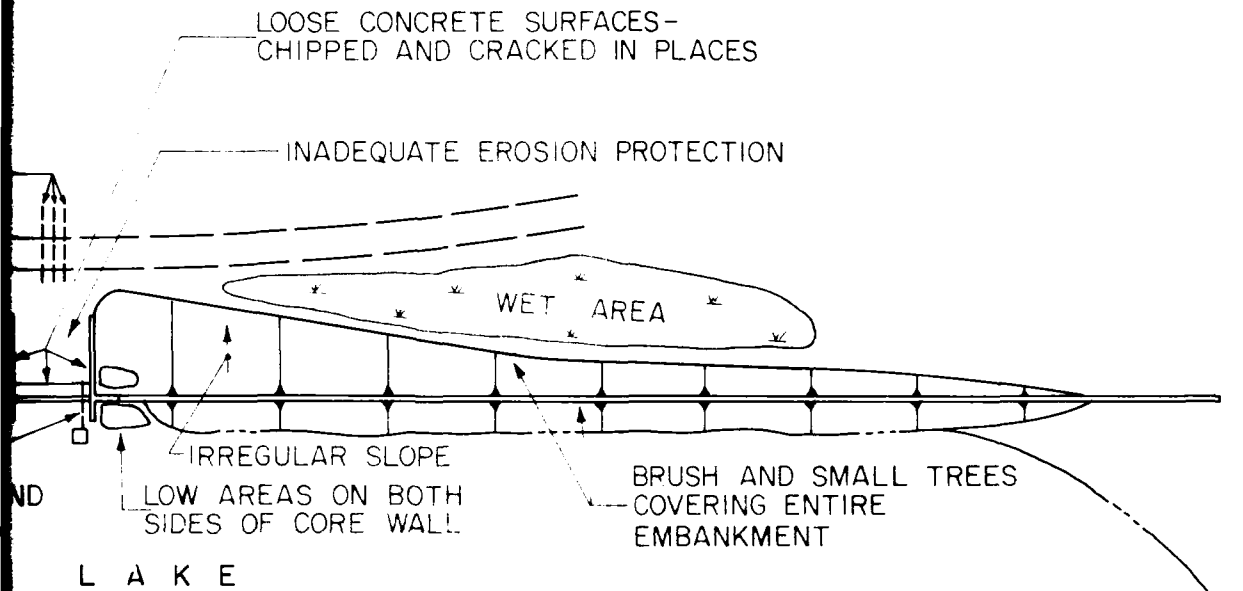

IN. = 60 FT.
 120

CONCRETE
 ALL

5.9

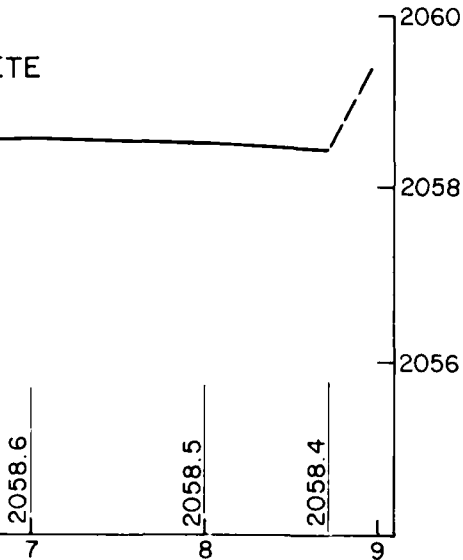

PHASE I INSPECTION REPORT
 NATIONAL DAM INSPECTION PROGRAM
 CRYSTAL LAKE DAM
 POCONO SPRINGS ESTATES, INC.
**RESULTS OF
 VISUAL INSPECTION**
 JANUARY 1981 EXHIBIT B-1

APPENDIX C
PHOTOGRAPHS

CRYSTAL LAKE DAM



A. Downstream Slope Looking Toward
Left Abutment



B. Upstream Slope Looking Toward
Left Abutment

CRYSTAL LAKE DAM



C. Spillway



D. Low-level Outlet Pipe

CRYSTAL LAKE DAM



E. Spillway (Downstream Side)

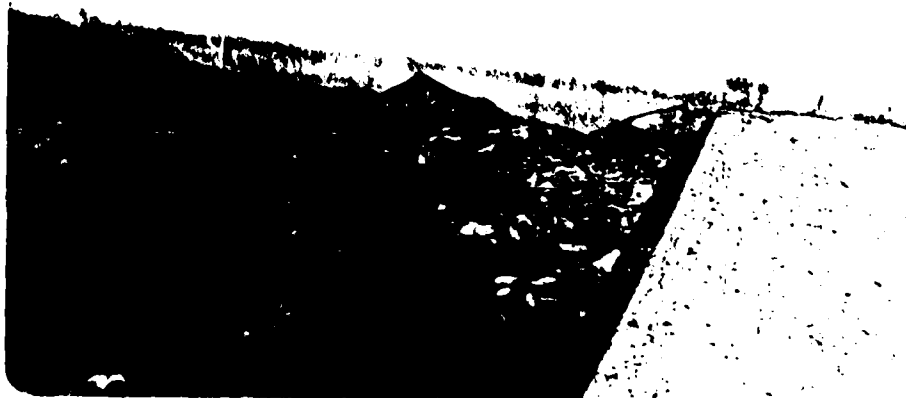

F. Concrete Deterioration on Left
Spillway Training Wall

CRYSTAL LAKE DAM



G. Spillway Discharge Channel



H. Top of Concrete Corewall

CRYSTAL LAKE DAM

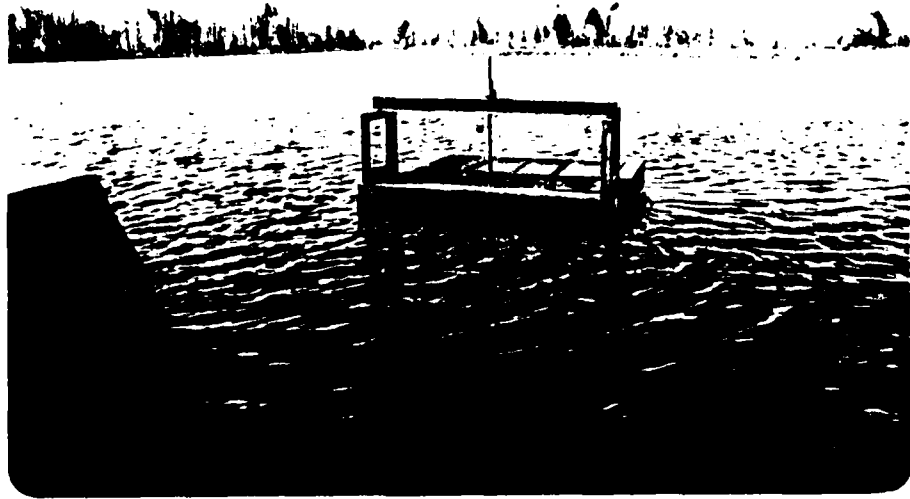

I. Outlet Works Intake Structure



J. "Canoe Harbor" Area

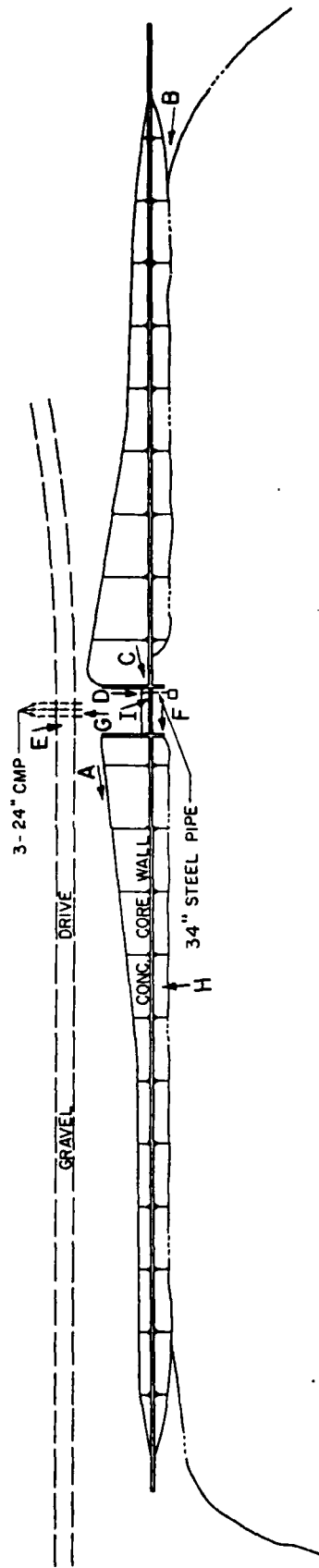

CRYSTAL LAKE

NOT TO SCALE

← LOCATION AND ORIENTATION OF CAMERA
 A PHOTOGRAPH IDENTIFICATION LETTER

PHASE I INSPECTION REPORT
 NATIONAL DAM INSPECTION PROGRAM
 CRYSTAL LAKE DAM
 POCONO SPRINGS ESTATES, INC.
 GUIDE TO LOCATION
 OF PHOTOGRAPHS
 JANUARY 1981 EXHIBIT C-1

APPENDIX D
HYDROLOGY AND HYDRAULICS

APPENDIX D

HYDROLOGY AND HYDRAULICS

Spillway Capacity Rating:

In the recommended Guidelines for Safety Inspection of Dams, the Department of the Army, Office of the Chief of Engineers (OCE), established criteria for rating the capacity of spillways. The recommended Spillway Design Flood (SDF) for the size (small, intermediate, or large) and hazard potential (low, significant, or high) classification of a dam is selected in accordance with the criteria. The SDF for those dams in the high hazard category varies between one-half of the Probable Maximum Flood (PMF) and the PMF. If the dam and spillway are not capable of passing the SDF without overtopping failure, the spillway capacity is rated as inadequate. If the dam and spillway are capable of passing one-half of the PMF without overtopping failure, or if the dam is not in the high hazard category, the spillway capacity is not rated as seriously inadequate. A spillway capacity is rated as seriously inadequate if all of the following conditions exist:

(a) There is a high hazard to loss of life from large flows downstream of the dam.

(b) Dam failure resulting from overtopping would significantly increase the hazard to loss of life downstream from the dam from that which would exist just before overtopping failure.

(c) The dam and spillway are not capable of passing one-half of the PMF without overtopping failure.

Description of Model:

If the Owner has not developed a PMF for the dam, the watershed is modeled with the HEC-1DB computer program, which was developed by the U.S. Army Corps of Engineers. The HEC-1DB computer program calculates a PMF runoff hydrograph (and percentages thereof) and routes the flows through both reservoirs and stream sections. In addition, it has the capability to simulate an overtopping dam failure. By modifying the rainfall criteria, it is also possible to model the 100-year flood with the program.

APPENDIX D

DELAWARE River Basin

Name of Stream: LEHIGH RIVER
 Name of Dam: CRYSTAL LAKE DAM
 NDI ID No.: PA-00096
 DER ID No.: 64-6

Latitude: N 41° 16.5' Longitude: W 75° 24.4'
 Top of Dam Elevation: 2058.4 FEET
 Streambed Elevation: 2045.4 Height of Dam: 13 ft
 Reservoir Storage at Top of Dam Elevation: 754 acre-ft
 Size Category: SMALL
 Hazard Category: SIGNIFICANT (see Section 5)
 Spillway Design Flood: 100-YEAR TO 1/2 PMF
(USE 1/2 PMF - SEE SECTION 5)

UPSTREAM DAMS - N/A

Name	Distance from Dam (miles)	Height (ft)	Storage at top of Dam Elevation (acre-ft)	Remarks

DOWNSTREAM DAMS

<u>UPPER KLONDIKE</u>	<u>2.9</u>	<u>14</u>	<u>131</u>	<u>DER ID 64-175</u>
<u>LOWER KLONDIKE</u>	<u>3.2</u>	<u>18</u>	<u>219</u>	<u>DER ID 64-175</u>
<u>JOHNSON</u>	<u>3.8</u>	<u>12</u>	<u>328</u>	<u>DER ID 35-50</u>
<u>LAKE LEHIGH</u>	<u>4.5</u>	<u>10</u>	<u>183</u>	<u>DER ID 64-51</u> <u>WEST END POND</u>

DELAWARE

River Basin

Name of Stream: LEHIGH RIVER

Name of Dam: CRYSTAL LAKE DAM

DETERMINATION OF PMF RAINFALL & UNIT HYDROGRAPH

UNIT HYDROGRAPH DATA:

Sub-area	Drainage Area (square miles)	Cp (1)	Ct (2)	L miles (3)	L _{ca} miles (4)	L' miles (5)	Tp hours (6)	Map Area (7)	Plate (8)
A-1	0.77	0.45	2.1	—	—	0.59	1.53	2	B
Total									

(See Sketch on Sheet D-4)

(1) & (2): Snyder Unit Hydrograph coefficients supplied by Baltimore District, Corps of Engineers on maps and plates referenced in (7) & (8)

The following are measured from the outlet of the subarea:

(3): Length of main watercourse extended to divide

(4): Length of main watercourse to the centroid

The following is measured from the upstream end of the reservoir at normal pool:

(5): Length of main watercourse extended to divide

(6): $T_p = C_t \times (L \times L_{ca})^{0.3}$, except where the centroid of the subarea is located in the reservoir. Then $T_p = C_t \times (L')^{0.6}$

Initial flow is assumed at 1.5 cfs/sq. mile

Computer Data: QRCSN = -0.05 (5% of peak flow)

RTIOR = 2.0

RAINFALL DATA:

PMF Rainfall Index = 22.0 in., 24 hr., 200 sq. mile
 Hydromet. 40 (Susquehanna Basin) Hydromet. 33 (Other Basins)

Zone: N/A /

Geographic Adjustment Factor: N/A 1.0

Revised Index Rainfall: N/A 22.0

RAINFALL DISTRIBUTION (percent)

Time	Percent
6 hours	<u>111</u>
12 hours	<u>123</u>
24 hours	<u>133</u>
48 hours	<u>142</u>
72 hours	<u> </u>
96 hours	<u> </u>

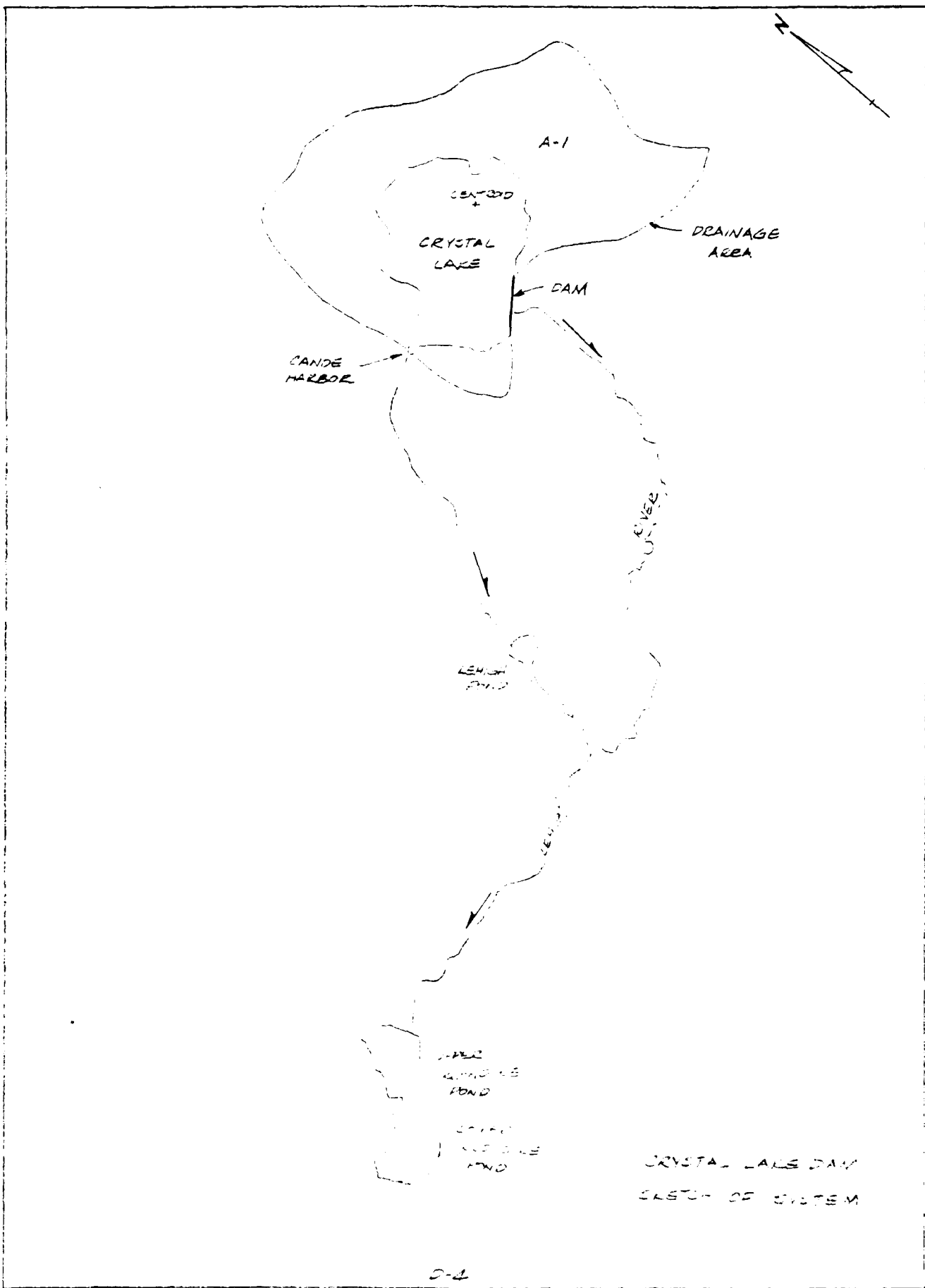

Data for Dam at Outlet of Subarea A-1 (See sketch on Sheet D-4)

Name of Dam: CRYSTAL LAKE DAM

STORAGE DATA:

Elevation	Area (acres)	Storage		Remarks
		million gals	acre-ft	
<u>2046.9</u> =ELEVO*	0	0	0	
<u>2055.9</u> =ELEV1	<u>133</u> =A1	<u>130</u>	<u>399</u> =S1	<u>SPILLWAY CREST DATA FROM DER</u>
<u>2057.9</u>				
<u>2058.4</u>	<u>152</u>	<u>246</u>	<u>755</u>	<u>LOW TOP OF DAM</u>
<u>2060.0</u>	<u>164</u>	<u>328</u>	<u>1007</u>	
<u>2080.0</u> **	<u>259</u>	<u>1694</u>	<u>5199</u>	

* ELEVO = ELEV1 - (3S₁/A₁)
 ** Planimetered contour at least 10 feet above top of dam

Reservoir Area at Normal Pool is 27 percent of subarea watershed.

BREACH DATA: NO BREACH ANALYSIS REQUIRED

See Appendix B for sections and existing profile of the dam.

Soil Type from Visual Inspection: _____

Maximum Permissible Velocity (Plate 28, EM 1110-2-1601) _____ fps
 (from $Q = CLH^{3/2} = V \cdot A$ and depth = $(2/3) \times H$) & $A = L \cdot \text{depth}$

HMAX = $(4/9 V^2/C^2)$ = _____ ft., C = _____ Top of Dam El. = _____

HMAX + Top of Dam El. = _____ = FAILEL
 (Above is elevation at which failure would start)

Dam Breach Data:

BRWID = _____ ft (width of bottom of breach)
 Z = _____ (side slopes of breach)
 ELBM = _____ (bottom of breach elevation, minimum of zero storage elevation)
 WSEL = _____ (normal pool elevation)
 T FAIL = _____ mins = _____ hrs (time for breach to develop)

Data for Dam at Outlet of Subarea A-1

Name of Dam: CRYSTAL LAKE DAM

SPILLWAY DATA:

	Existing Conditions	Design Conditions
Top of Dam Elevation	<u>2058.4 (LOW POINT)</u>	<u>(N/A)</u>
Spillway Crest Elevation	<u>2055.9</u>	<u></u>
Spillway Head Available (ft)	<u>2.5</u>	<u></u>
Type Spillway	<u>BROAD-CRESTED CONCRETE</u>	<u></u>
"C" Value - Spillway	<u>2.7</u>	<u></u>
Crest Length - Spillway (ft)	<u>29.5</u>	<u></u>
Spillway Peak Discharge (cfs)	<u>315</u>	<u></u>
Auxiliary Spillway Crest Elev.	<u></u>	<u></u>
Auxiliary Spill. Head Avail. (ft)	<u></u>	<u></u>
Type Auxiliary Spillway	<u></u>	<u></u>
"C" Value - Auxiliary Spill. (ft)	<u>N/A</u>	<u></u>
Crest Length - Auxil. Spill. (ft)	<u></u>	<u></u>
Auxiliary Spillway	<u></u>	<u></u>
Peak Discharge (cfs)	<u></u>	<u></u>
Combined Spillway Discharge (cfs)	<u></u>	<u></u>

Spillway Rating Curve: $Q = CLH^{1.5} = 2.7(29.5)H^{1.5} = 79.7 H^{1.5}$

Elevation	Q Spillway (cfs)	Q Auxiliary Spillway (cfs)	Combined (cfs)
<u></u>	<u></u>	<u></u>	<u></u>
<u></u>	<u></u>	<u></u>	<u></u>
<u></u>	<u></u>	<u></u>	<u></u>
<u></u>	<u></u>	<u></u>	<u></u>
<u></u>	<u></u>	<u></u>	<u></u>
<u></u>	<u></u>	<u></u>	<u></u>
<u></u>	<u></u>	<u></u>	<u></u>
<u></u>	<u></u>	<u></u>	<u></u>
<u></u>	<u></u>	<u></u>	<u></u>
<u></u>	<u></u>	<u></u>	<u></u>
<u></u>	<u></u>	<u></u>	<u></u>
<u></u>	<u></u>	<u></u>	<u></u>
<u></u>	<u></u>	<u></u>	<u></u>
<u></u>	<u></u>	<u></u>	<u></u>
<u></u>	<u></u>	<u></u>	<u></u>
<u></u>	<u></u>	<u></u>	<u></u>
<u></u>	<u></u>	<u></u>	<u></u>
<u></u>	<u></u>	<u></u>	<u></u>
<u></u>	<u></u>	<u></u>	<u></u>
<u></u>	<u></u>	<u></u>	<u></u>
<u></u>	<u></u>	<u></u>	<u></u>
<u></u>	<u></u>	<u></u>	<u></u>

<u>OUTLET WORKS RATING:</u>	<u>Outlet 1</u>	<u>Outlet 2</u>	<u>Outlet 3</u>
Invert of Outlet	<u>2046.0</u>	<u></u>	<u></u>
Invert of Inlet	<u>2046.7</u>	<u></u>	<u></u>
Type	<u>STEEL</u>	<u></u>	<u></u>
Diameter (ft) = D	<u>2.8 FT.</u>	<u></u>	<u></u>
Length (ft) = L	<u>30 FT.</u>	<u></u>	<u></u>
Area (sq. = A	<u>6.15</u>	<u></u>	<u></u>
N	<u>0.015</u>	<u></u>	<u></u>
K Entrance	<u>0.5</u>	<u></u>	<u></u>
K Exit	<u>1.0</u>	<u></u>	<u></u>
K Friction = $29.1N^{2L/R^{4/3}}$	<u>0.3</u>	<u></u>	<u></u>
Sum of K	<u>1.8</u>	<u></u>	<u></u>
(1/K) $0.5 = C$	<u>0.75</u>	<u></u>	<u></u>
Maximum Head (ft) = HM	<u>10.0 ±</u>	<u></u>	<u></u>
Q = $CA\sqrt{2g(HM)}$ (cfs)	<u>117</u>	<u></u>	<u></u>
Q Combined (cfs)	<u>N/A</u>	<u></u>	<u></u>

BY _____ DATE _____
CHKD. BY _____ DATE _____

SUBJECT _____

SHEET NO. _____ OF _____
JOB. NO. _____

SELECTED COMPUTER OUTPUT

<u>Item</u>	<u>Page</u>
Multi-ratio Analysis	
1. Including outflows at Canoe Harbor	
Input	D-8
Summary of Peak Flows	D-9
Overtopping Summary	D-10
2. Excluding outflows at Canoe Harbor	
Input	D-11
Summary of Peak Flows	D-12
Overtopping Summary	D-13

PEAK FLOW AND STORAGE (END OF PERIOD) SUMMARY FOR MULTIPLE PLAN-RATIO ECONOMIC COMPUTATIONS
 FLOWS IN CUBIC FEET PER SECOND (CUBIC METERS PER SECOND)
 AREA IN SQUARE MILES (SQUARE KILOMETERS)

OPERATION	STATION	AREA	PLAN	RATIOS APPLIED TO FLOWS				
				RATIO 1	RATIO 2	RATIO 3	RATIO 4	RATIO 5
				1.00	.80	.60	.50	.40
HYDROGRAPH AT	1	.77	1	1785.	1428.	1071.	892.	714.
	(1.99)	(50.53)	40.43)	30.32)	25.27)	20.21)
ROUTED TO	1	.77	1	1315.	815.	380.	269.	199.
	(1.99)	(37.24)	23.08)	10.75)	7.62)	5.63)

D-9

SUMMARY OF DAM SAFETY ANALYSIS

PLAN 1

ELEVATION STORAGE OUTFLOW
 2055.90 399. 0.
 2059.40 755. 361.
 SPILLWAY CREST 2055.90 399. 0.
 TOP OF DAM 2059.40 755. 361.

RATD OF PHF	MAXIMUM RESERVOIR W.S.ELEV	MAXIMUM DEPTH OVER DAM	MAXIMUM STORAGE AC-FT	MAXIMUM OUTFLOW CFS	DURATION OVER TOP HOURS	TIME OF MAX OUTFLOW HOURS	TIME OF FAILURE HOURS
1.00	2059.04	.64	854.	1315.	7.75	43.00	0.00
.80	2058.83	.43	822.	815.	6.25	43.75	0.00
.60	2058.64	.04	761.	380.	2.25	45.00	0.00
.50	2058.12	0.00	713.	269.	0.00	45.50	0.00
.40	2057.74	0.00	656.	199.	0.00	45.75	0.00

D-10

*Overtopping Summary
 Crystal Lake Dam*

EXCLUDES OUTFLOW
AT CANOE HARBOE

FLOOD HYDROGRAPH PACKAGE (HFC-1)
DAM SAFETY VERSION JULY 1978
LAST MODIFICATION 01 APR 80

NATIONAL DAM INSPECTION PROGRAM
BALTIMORE DISTRICT CORPS OF ENGINEERS

	A1	A2	A3	B1	J1	K1	M	P	T	W	X	K	K1	Y1	SA	SE	SE	SD	SL	SK
1																				
2	300	0	15	0	5	1	0.6	0.5	0.4											
3					1.0	0.8	0.6	0.5	0.4											
4					0	1														
5																				
6																				
7																				
8																				
9																				
10																				
11																				
12																				
13																				
14																				
15																				
16																				
17																				
18																				
19																				
20																				
21																				
22																				
23																				
24																				
25																				

PEAK FLOW AND STORAGE (END OF PERIOD) SUMMARY FOR MULTIPLE PLAN-RATIO ECONOMIC COMPUTATIONS
 FLOWS IN CUBIC FEET PER SECOND (CUBIC METERS PER SECOND)
 AREA IN SQUARE MILES (SQUARE KILOMETERS)

OPERATION	STATION	AREA	PLAN	RATIO 1	RATIOS APPLIED TO FLOWS				
					RATIO 2	RATIO 3	RATIO 4	RATIO 5	
				1.00	.80	.60	.50	.40	
HYDROGRAPH AT	1	.77	1	1785	1428	1071	892	714	
	(1.99	(50.53)(40.43)(30.32)(25.27)(20.21)(
ROUTED TO	1	.	1	1257	737	333	264	199	
	(1.99)	(35.59)(20.86)(9.44)(7.67)(5.63)(

SUMMARY OF DAM SAFETY ANALYSIS

PLAN 1

RATIO OF PMF	ELEVATION STORAGE OUTFLOW	INITIAL VALUE	SPILLWAY CREST	TOP OF DAM	MAXIMUM STORAGE AC-FT	MAXIMUM OUTFLOW CFS	DURATION OVER TOP HOURS	TIME OF MAX OUTFLOW HOURS	TIME OF FAILURE HOURS
1.00	2059.17	2055.90	2055.90	2059.40	875.	1257.	9.25	43.25	0.00
.80	2058.95	399.	399.	755.	840.	737.	7.75	44.00	0.00
.60	2058.69	0.	0.	515.	768.	333.	3.50	45.50	0.00
.50	2058.12				713.	264.	0.00	45.50	0.00
.40	2057.74				656.	199.	0.00	45.75	0.00

*Overtopping Summary
Crystal Lake Dam*

BY _____ DATE _____
CHKD BY _____ DATE _____

SUBJECT _____

SHEET NO. _____ OF _____
JOB NO. _____

CRYSTAL LAKE DAM

Summary of Pertinent Results

Multi-ratio Analysis

Excluding overflow at canoe harbor:

	<u>PMF</u>	<u>1/2 PMF</u>
Rainfall (inches)	24.99	-
Runoff (inches)	23.25	11.63
Peak Inflow (cfs)	1785	892
Peak Outflow (cfs)	1257	264
Depth of Overtopping (ft.)	0.77	0
Duration of Overtopping (hrs.)	9.25	0

Including overflow at canoe harbor:

Peak Outflow *	1315	269
Depth of Overtopping	0.64	0
Duration of Overtopping	7.75	0

* Note: Rainfall, runoff and peak inflow are the same as above.

ADDITIONAL
AREAS NOT

APPROXIMATE MINIMUM LIMIT
OF DOWNSTREAM FLOODING
SHOULD DAM FAILURE OCCUR

NOTES:

1. LIMITS OF DOWNSTREAM FLOODING ARE ESTIMATES BASED ON VISUAL OBSERVATIONS.
2. CIRCLED NUMBERS INDICATE STATIONS USED IN COMPUTER ANALYSIS.
3. THIS MAP SHOULD NOT BE USED IN CONNECTION WITH THE EMERGENCY OPERATION AND WARNING PLAN.

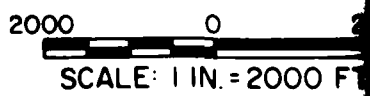

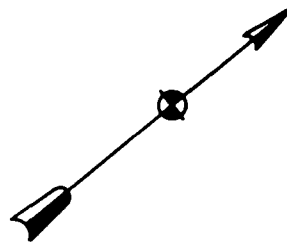

NAL POSSIBLE DAMAGE
NOT SHOWN



LIMITS
DURING
OCCUR

CRYSTAL LAKE DAM

FLOWERING

2000
00 FT.

PHASE I INSPECTION REPORT
NATIONAL DAM INSPECTION PROGRAM
CRYSTAL LAKE DAM
POCONO SPRINGS ESTATES, INC.
DOWNSTREAM
DEVELOPMENT PLAN
JANUARY 1981 EXHIBIT D-1

APPENDIX E

PLATES

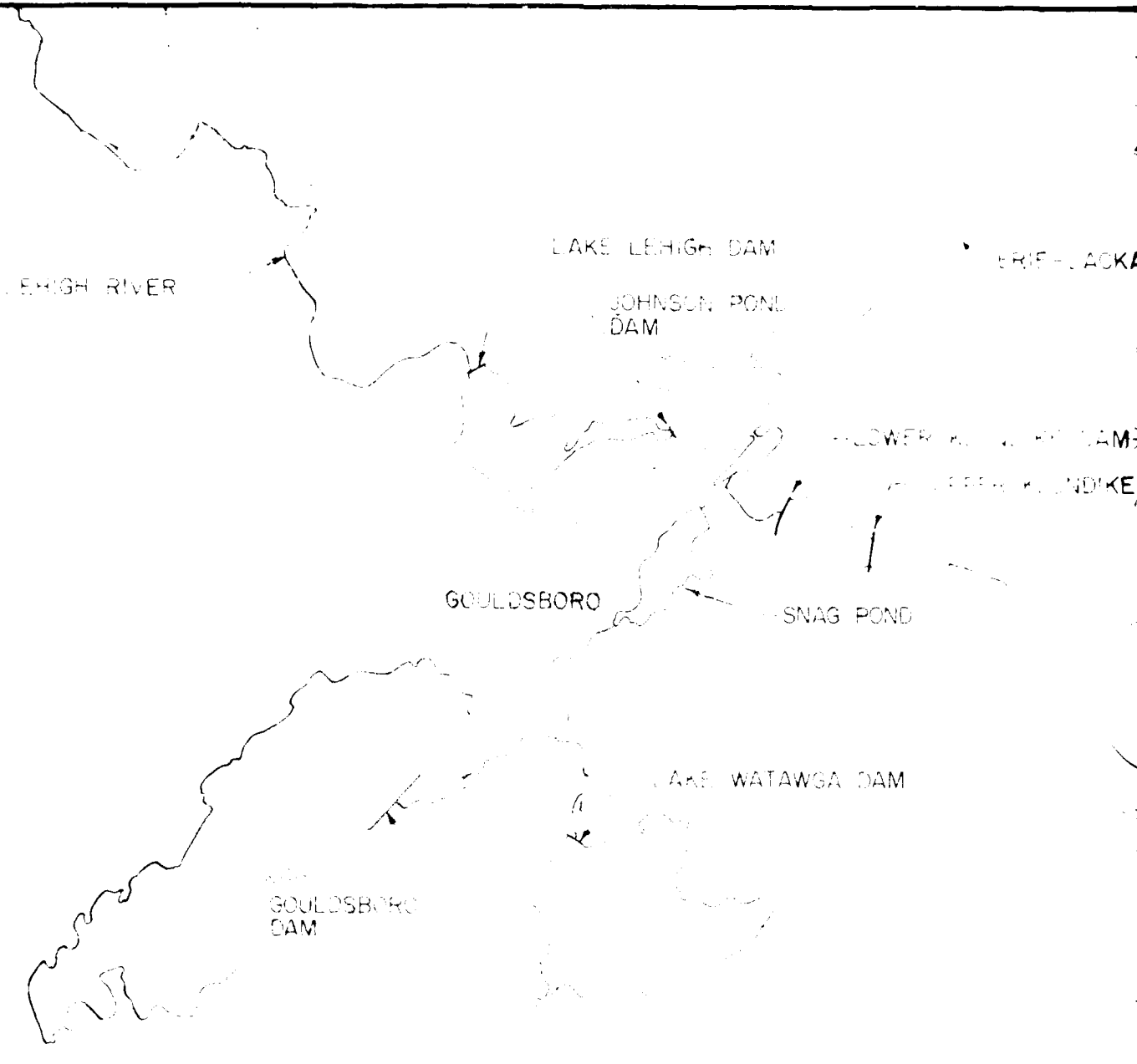

LEHIGH RIVER

LAKE LEHIGH DAM

ERIE-LACKAWANNA RIVER

JOHNSON POND DAM

FLOWER HILL DAM

DIKE

GOULDSBORO

SNAG POND

LAKE WATAWGA DAM

GOULDSBORO DAM

2000 0 2000

SCALE: 1 IN. = 2000 FT

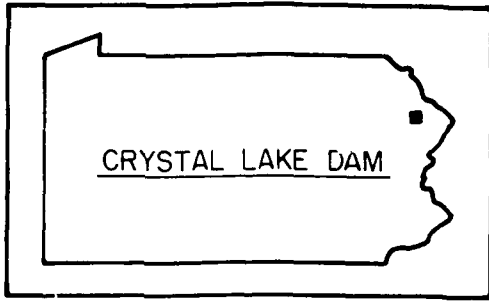

CRYSTAL LAKE DAM

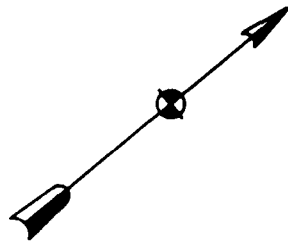

7 1/2 MINUTE QUADRANGLES:
TOBYHANNA, PA.
STERLING, PA.

ACKAWANNA R.R.

DAM

DIKE DAM

LEHIGH RIVER

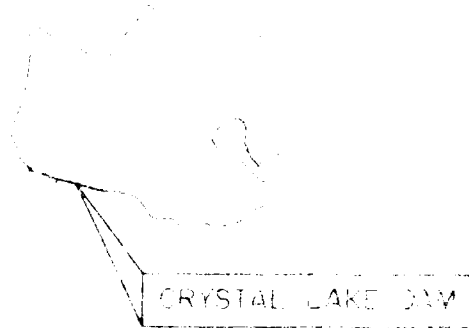

CRYSTAL LAKE DAM

PHASE I INSPECTION REPORT
NATIONAL DAM INSPECTION PROGRAM
CRYSTAL LAKE DAM
POCONO SPRINGS ESTATES, INC.

LOCATION MAP

JANUARY 1981

PLATE E-1

2000

00 FT

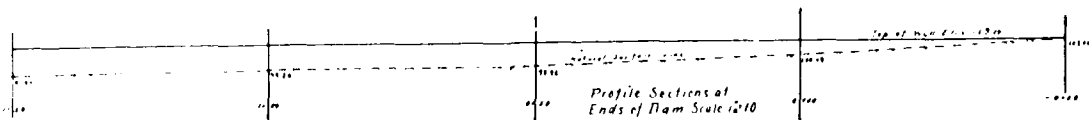
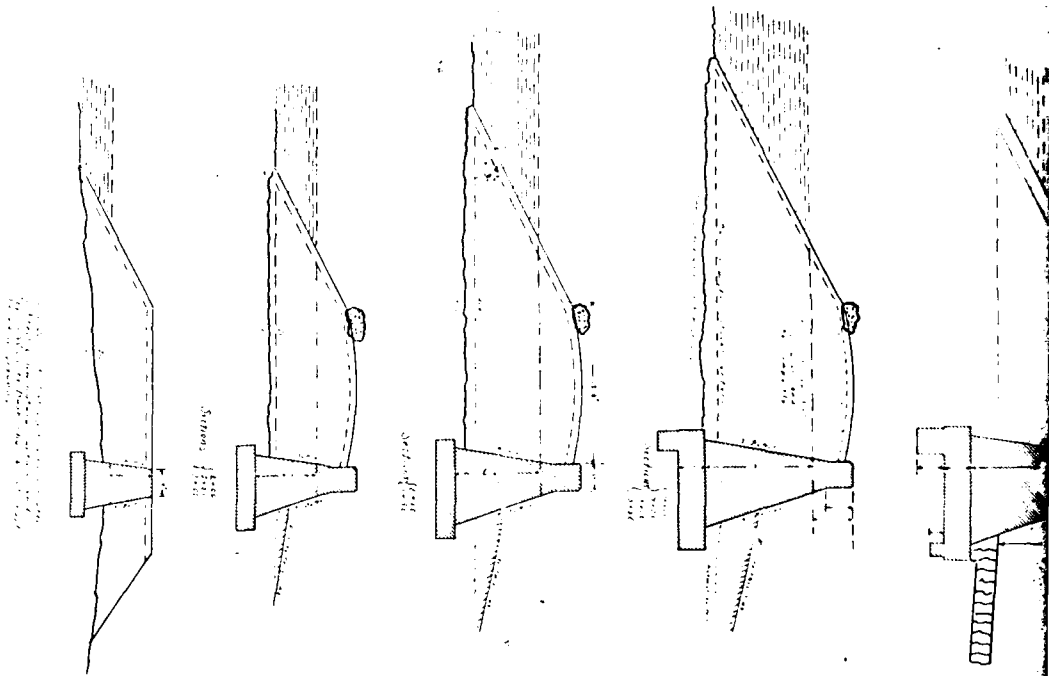
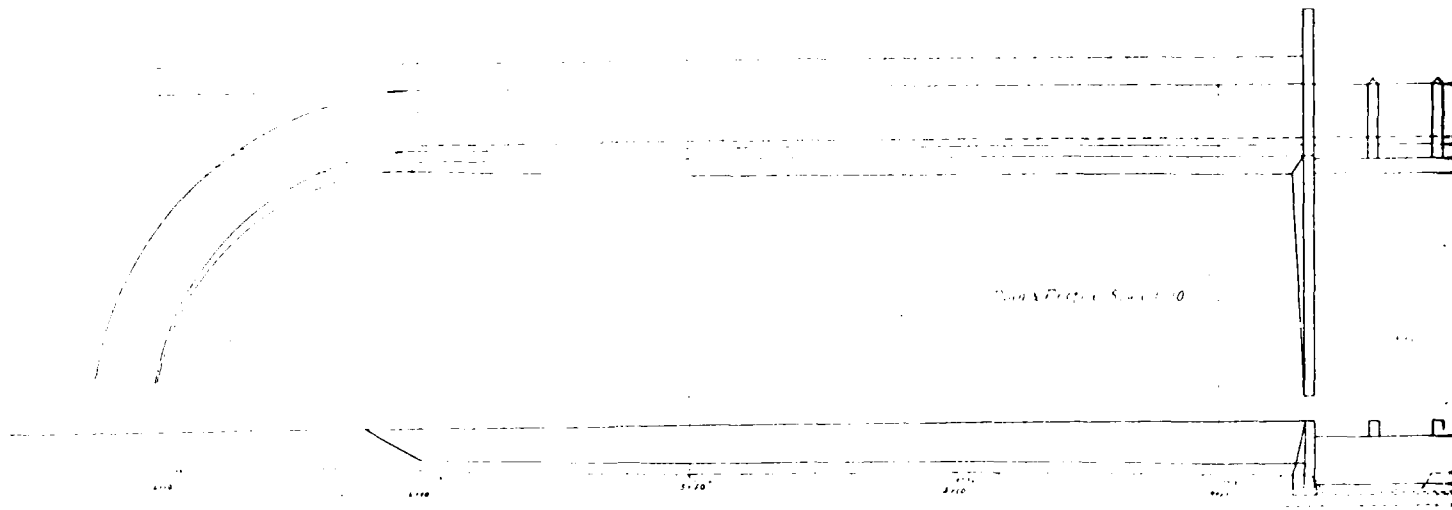

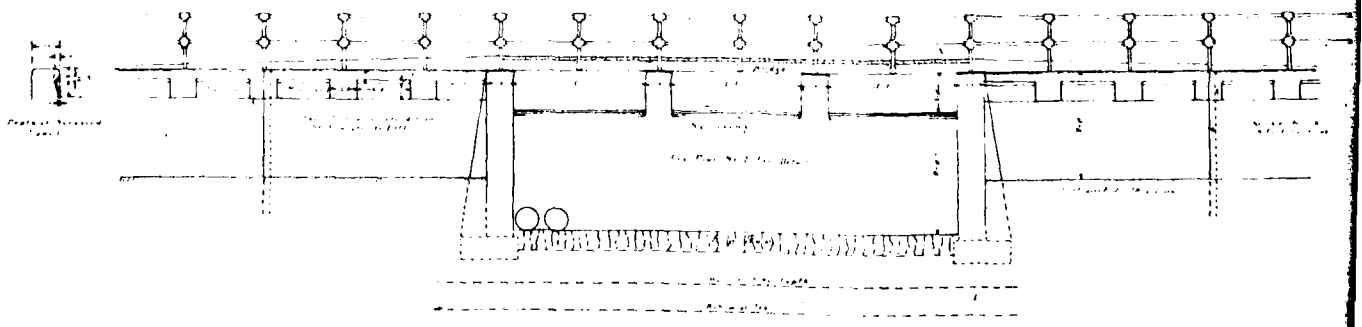
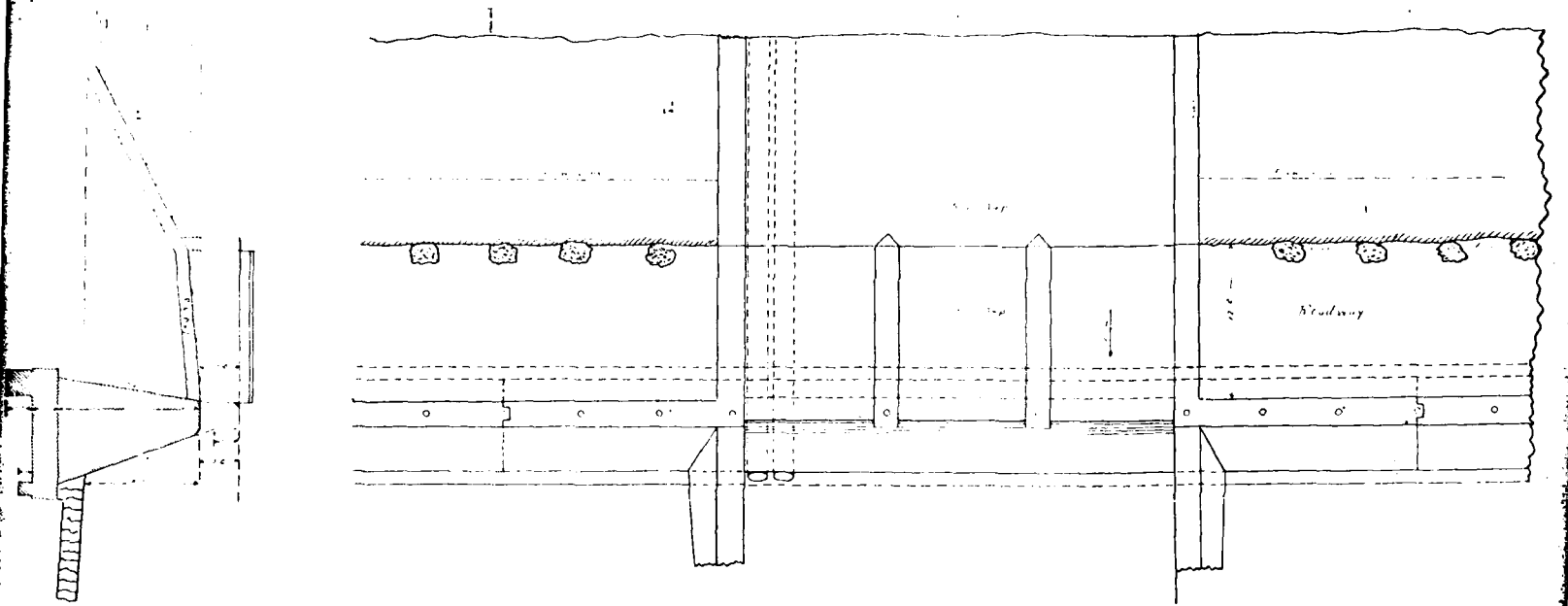
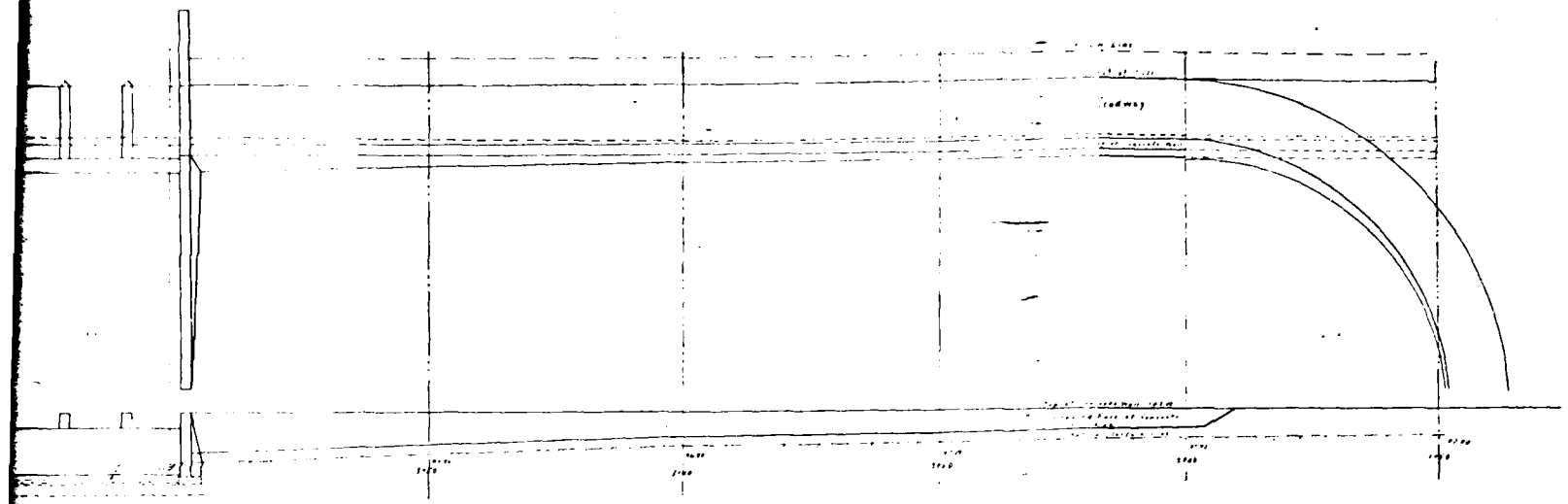

LAKE GENEVA DAM
 NEAR **GOULDSBORO** PA
 The Lake Geneva Park Association, Scranton, Pa.
 O. F. Pecknell Engineer, Sept. 6, 1913, Scale 1/4" = 1'-0"
 REVISED NOV 28-1914

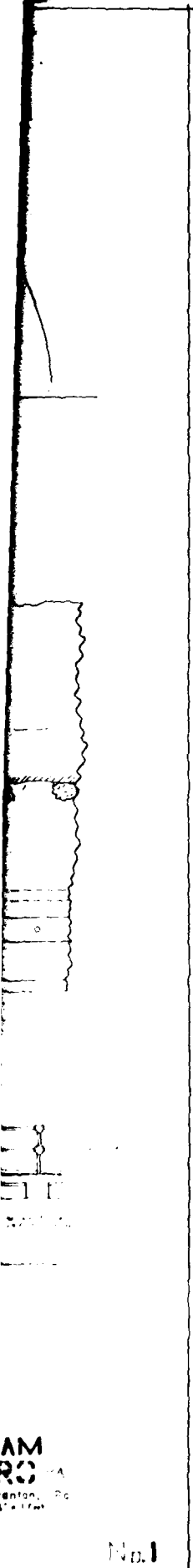

PHASE I INSPECTION REPORT
NATIONAL DAM INSPECTION PROGRAM
CRYSTAL LAKE DAM
POCONO SPRINGS ESTATES, INC.
DESIGN PLAN, PROFILE
AND SECTIONS
JANUARY 1981 PLATE E-2

AM
RO
enton, Pc
1981

No. 1

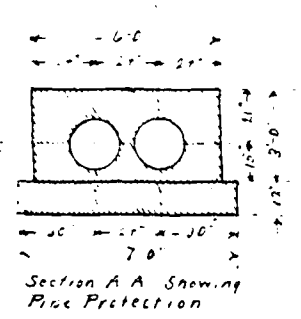
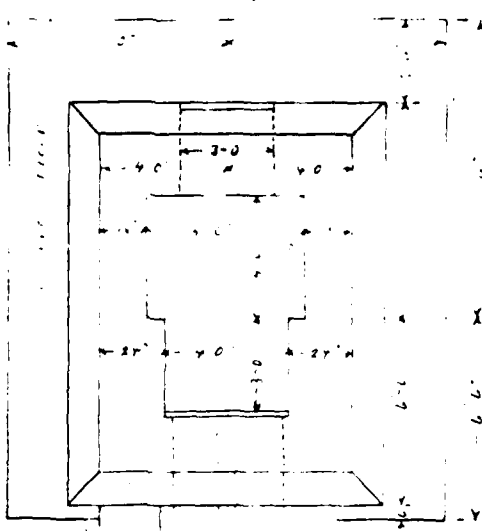

A - - - - - A

Asp. 14' 18" in 22'-0"

Top of wall to be 24"

Bottom of wall to be 18"

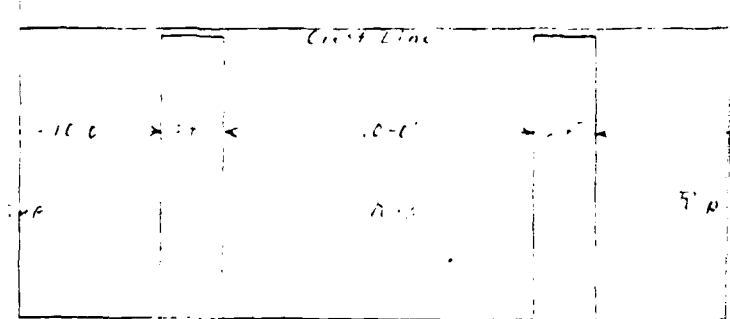

Reinforce corners

Sp. way

Sp. way

Sp. way

Asp. 14' 18" in 22'-0"

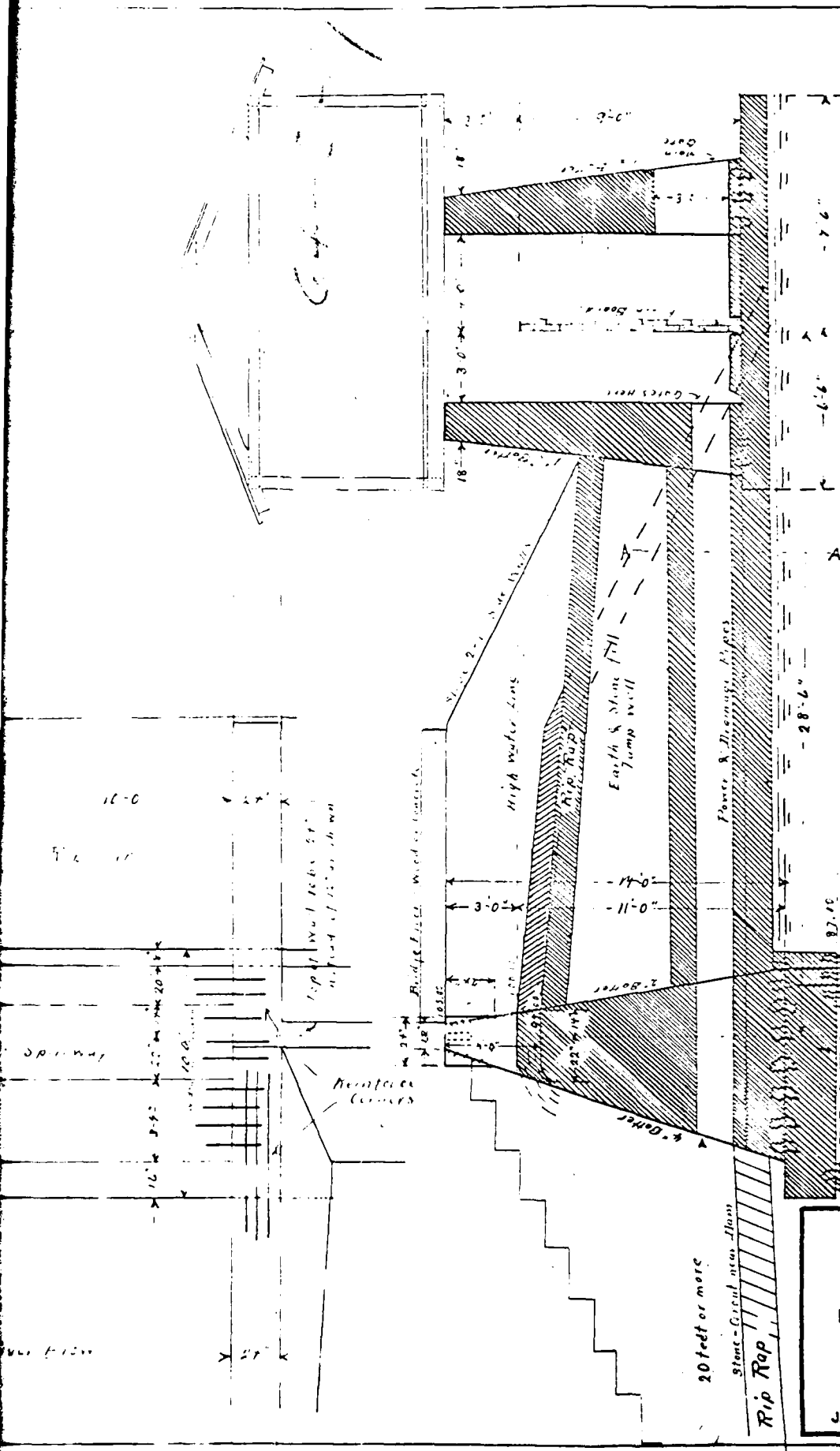

Section Showing Dam Construction
And Gate House Through Spillway.

Plan of Spillway and Gate House
Lake Geneva Dam near Goldsboro
Scale 1/2" = 1'-0" Oct 5 1914
O. Russell Ing Scranton Pa.
Revised Nov 28 1914

Plan # 2.

PHASE I INSPECTION REPORT
NATIONAL DAM INSPECTION PROGRAM
CRYSTAL LAKE DAM
POCONO SPRINGS ESTATES, INC.
SPILLWAY AND GATE
HOUSE DETAILS
JANUARY 1981 PLATE E-3

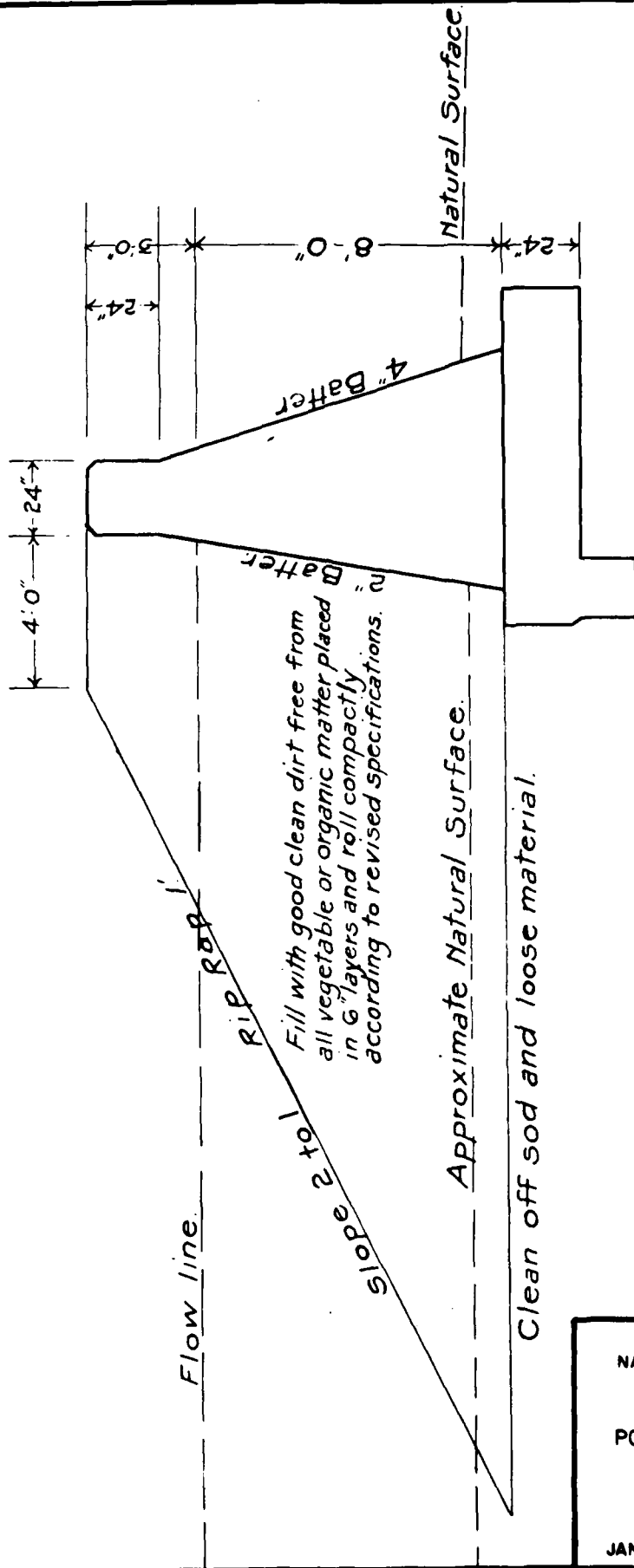

Flow line.

RIP RAP

Fill with good clean dirt free from all vegetable or organic matter placed in 6" layers and roll compactly according to revised specifications.

slope 2 to 1

Approximate Natural Surface.

Clean off sod and loose material.

PHASE I INSPECTION REPORT
 NATIONAL DAM INSPECTION PROGRAM
 CRYSTAL LAKE DAM
 POCONO SPRINGS ESTATES, INC.
 TYPICAL SECTION
 "AS-BUILT"
 JANUARY 1981 PLATE E-4

SECTION - A

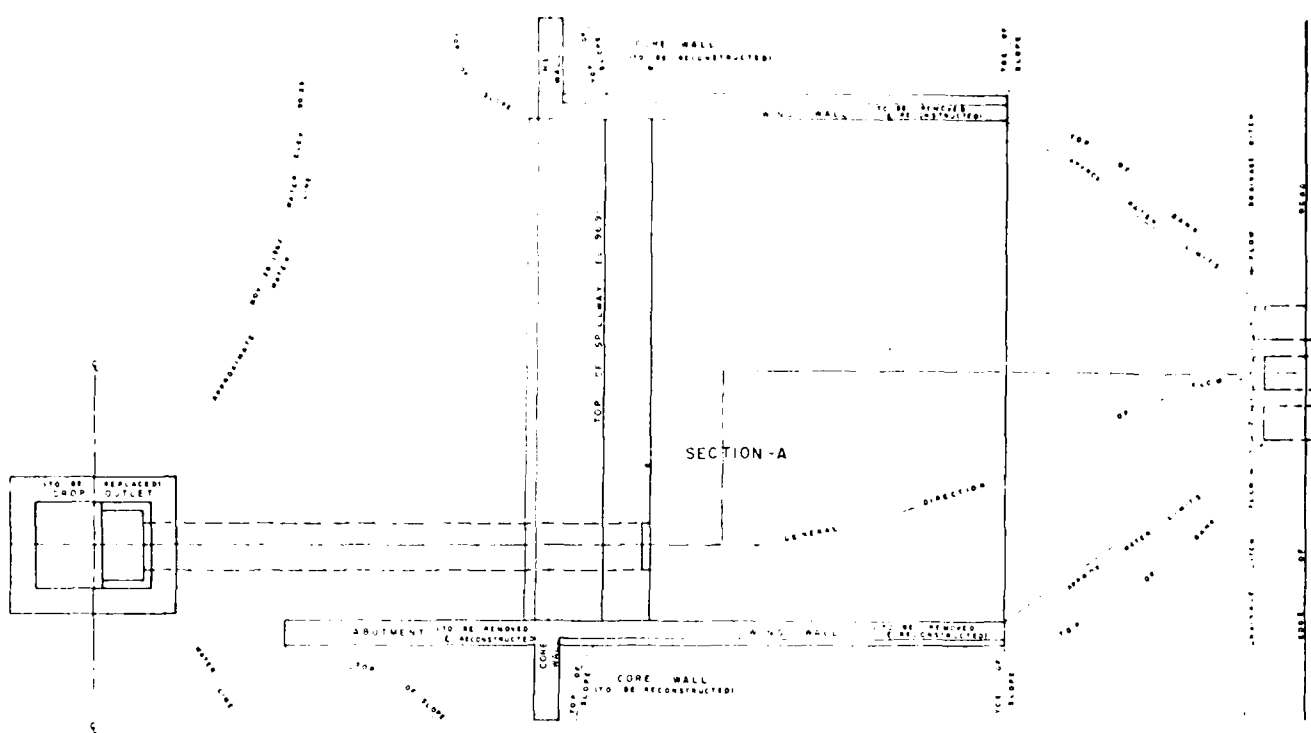

TOP VIEW

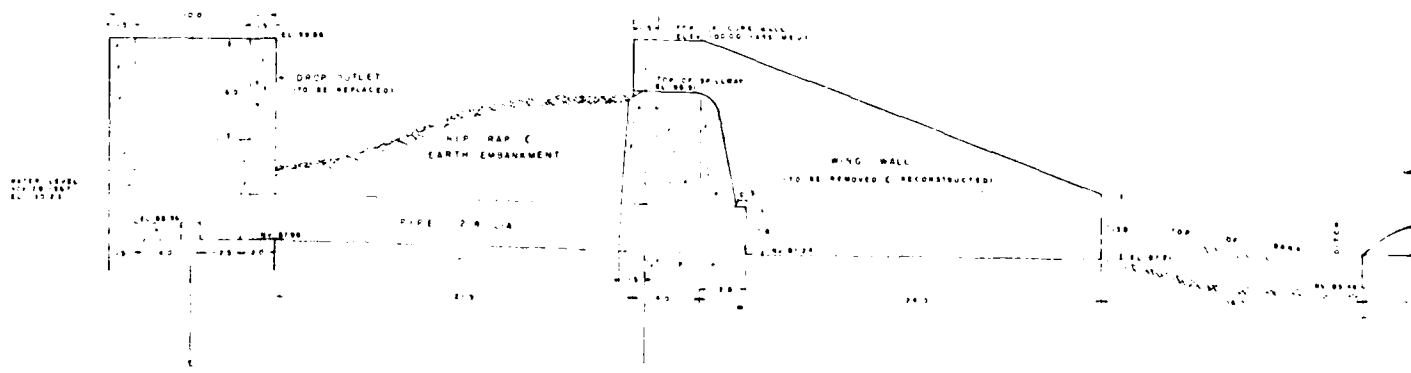

SIDE VIEW
SECTION - A

RECEIVED IN THE OFFICE OF WATER & POWER
 RESOURCES DIVISION DEPARTMENT OF FORESTS & WATERS ON THE 10th DAY OF DECEMBER A.D. 1967
 [Signature]
 File Clerk

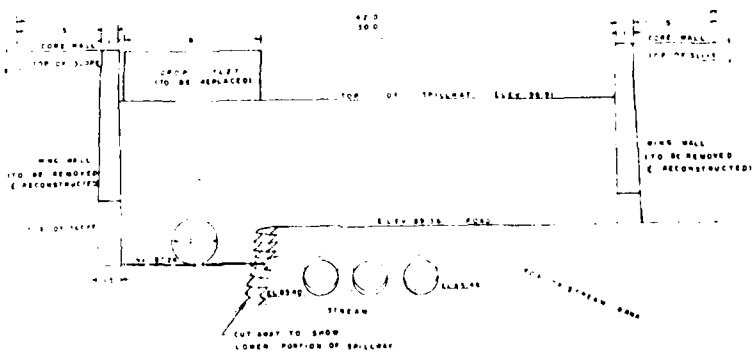
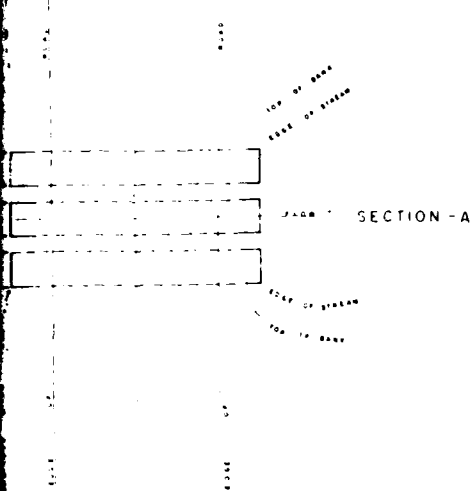

FRONT VIEW

DETAILS OF EXISTING
 SPILLWAY & OUTLET
 AT
 POCONO SPRINGS ESTATES, INC.
 (FORMERLY POCONO PEAK LAKE)

TRI-COUNTY ENGINEERS & LAND SURVEYORS INC
 37 BUDD LAKE RD HACKETTSTOWN, N.J.
 RICHARD N. HARRISON P.E. 7605-E

LEHIGH TWP WAYNE CO PENNSYLVANIA
 DECEMBER, 1967 SCALE 1" = 5'

PHASE I INS
 NATIONAL DAM
 CRYSTAL
 POCONO SPRING
 1967-68 M
 JANUARY 1981

PHASE I INSPECTION REPORT
NATIONAL DAM INSPECTION PROGRAM
CRYSTAL LAKE DAM
CRYSTAL SPRINGS ESTATES, INC.
1968 MODIFICATIONS
MAY 1981 PLATE E-5

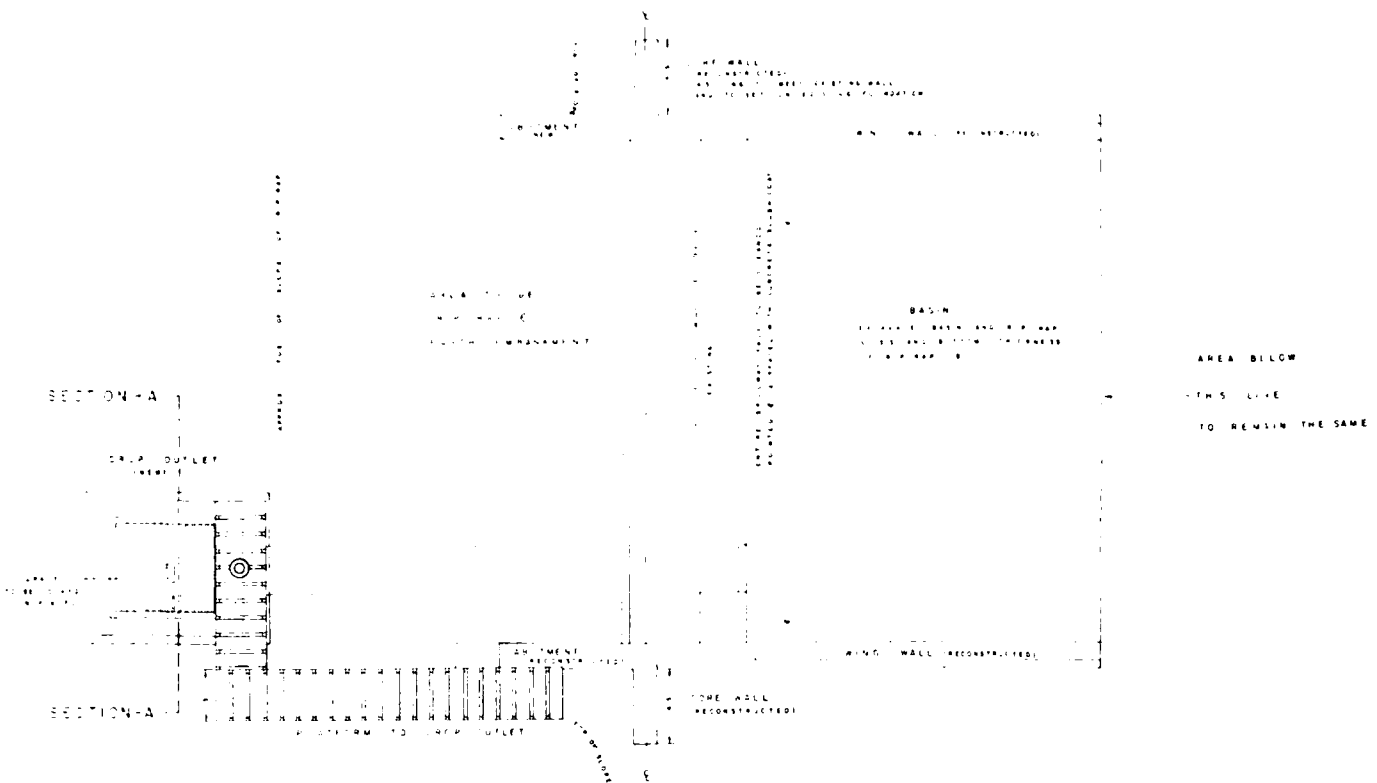

TOP VIEW

SCALE 1"=5'

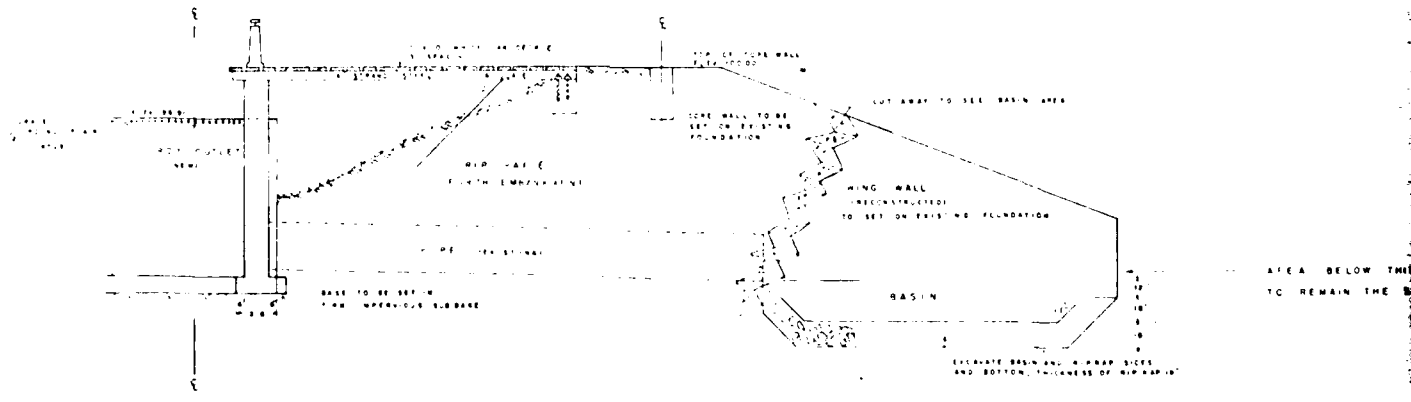

SIDE VIEW

SCALE 1"=5'

11/16/67
 R. N. HARRISON
 P. E. 7605-E

THE SAME

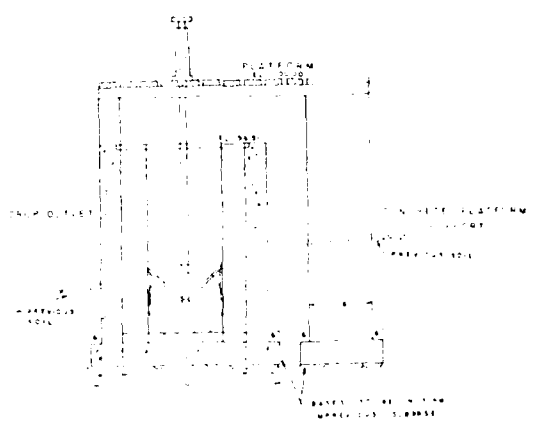

SECTION - A

SCALE 1" = 4'

BELOW THIS POINT
 REMAIN THE SAME

TRI COUNTY ENGINEERS & LAND SURVEYORS INC
 37 BUDD LAKE RD HACKETTSTOWN, N.J.
 RICHARD N. HARRISON P. E. 7605-E

RECONSTRUCTION DETAILS
 OF
 SPILLWAY & OUTLET
 AT
 POCONO SPRINGS ESTATES, INC
 (FORMERLY POCONO PEAK LAKE)
 LEHIGH TWP WAYNE CO PENNSYLVANIA
 DECEMBER, 1967 SCALES AS SHOWN

PHASE
 NATIONAL
 CRY
 POCONO
 1967-6
 JANUARY

PHASE I INSPECTION REPORT
NATIONAL DAM INSPECTION PROGRAM

CRYSTAL LAKE DAM

POCONO SPRINGS ESTATES, INC.

1967-68 MODIFICATIONS

JANUARY 1981

PLATE E-6

INC

EVANIA
SHOAN

APPENDIX F

GEOLOGY

CRYSTAL LAKE DAM

APPENDIX F

GEOLOGY

Crystal Lake Dam is located in Wayne County within the Appalachian Plateau Physiographic Province. The most pronounced topographic feature in the area is Camelback Mountain, which is part of the Pocono Plateau Escarpment. This escarpment has a well-defined southwestward trend from Camelback Mountain, but is irregular between Camelback Mountain and Mt. Pocono, which lies to the north. Streams east of the escarpment drain directly to the Delaware River, while those to the west drain to the Lehigh River.

The Pocono Plateau Section lies to the west of the escarpment. This area is relatively flat, with local relief seldom exceeding 100 feet. The topography has been greatly influenced by continental glaciation. Many features were created by deposition of glacial materials. The entire plateau lacks well-developed drainage.

East of the escarpment is the Glaciated Low Plateaus Section of the province. This area is characterized by preglacial erosional topography with locally thick glacial deposits. Local relief is generally 100 to 300 feet.

Bedrock units of the sections described above are the lithified sediments of offshore marine, marginal marine, deltaic and fluvial environments associated with the Devonian Period. These units include siltstones of the Mahantango Formation, siltstones and shales of the Trimmers Rock Formation, and seven mapped members of the Catskill Formation. These members include sandstones, siltstones, and shales of the Towamensing Member; sandstone, siltstone and shales of the Walcksville Member; sandstones, siltstones, and shale of the Beaverdam Run Member; sandstone and shale of the Long Run Member; sandstones and conglomerates in the Packerton Member; sandstone and some conglomerates in the Poplar Gap Member; and sandstones and conglomerates in the Duncannon Member.

Crystal Lake Dam is underlain by the Duncannon Member of the Catskill Formation. The Duncannon Member is predominantly a conglomerate and sandstone unit with some red siltstone and shale. Conglomerates present are generally thick-bedded with subangular to well-rounded quartz pebbles in a coarse-grained sandstone matrix. They are very well-indurated and have low porosity due to silica cementation. The sandstones are

predominantly fine- to medium-grained, thin- to thick-bedded and well-indurated with a clay and silica cement. Red sandstones near the top of the unit grade into red siltstone and shale, marking the contact with the Spechtly Kopf Formation. The Duncannon Member maintains very steep cut slopes and is reported to be an excellent foundation for heavy structures.

Bedrock is almost entirely overlain by glacial till of Late Wisconsin Age. This till is basically an unsorted mixture of clay, silt, sand, and gravel. It is moderately cohesive and is generally derived locally from the sandstones of the Catskill Formation. Thickness of the till varies from 3 to 100 feet, with an average thickness of 45 feet. Available information indicates that the dam is probably founded on this till.

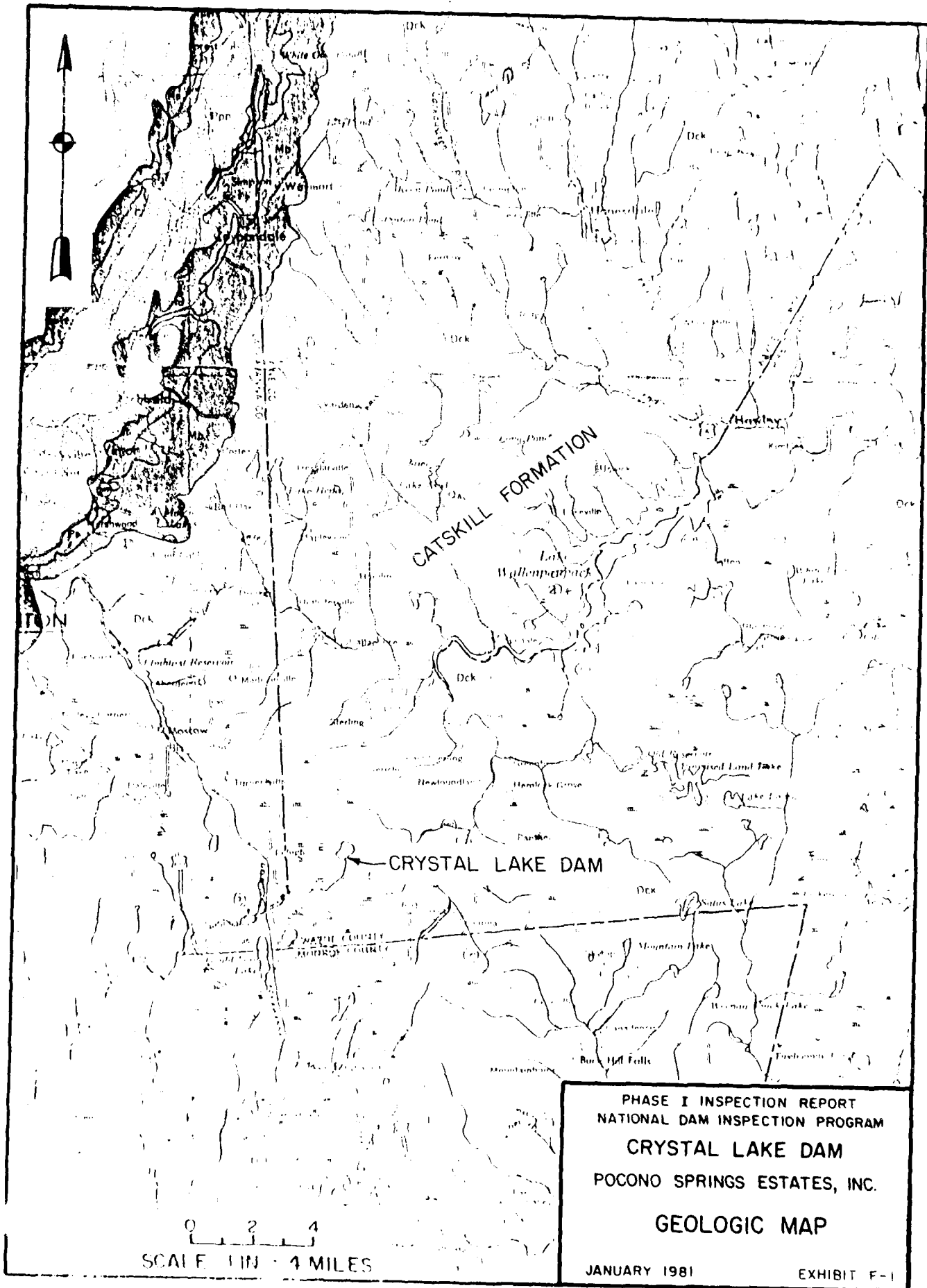

PHASE I INSPECTION REPORT
 NATIONAL DAM INSPECTION PROGRAM
CRYSTAL LAKE DAM
 POCONO SPRINGS ESTATES, INC.
GEOLOGIC MAP
 JANUARY 1981 EXHIBIT F-1

DATE
FILMED
— 8