

AD-A097 834

NAVAL SURFACE WEAPONS CENTER SILVER SPRING MD  
COMPOSITES FOR ELECTROCHEMICAL TECHNOLOGY. PART I. SURVEY OF EL--ETC(U)  
SEP 80 I A ANGRES, R A SUTULA

F/G 10/3

UNCLASSIFIED

NL

1-1

2

405783

END
DATE
FILMED
5-81
DTIC

NSWC TR 80-239

**LEVEL** *IV*

*12*

*fw*

**COMPOSITES FOR ELECTROCHEMICAL TECHNOLOGY  
PART I. SURVEY OF ELECTRODE CORROSION  
STUDIES FOR LEAD-ACID BATTERIES**

BY I. A. ANGRES  
R. A. SUTULA

RESEARCH AND TECHNOLOGY DEPARTMENT

SEPTEMBER 1980

**DTIC**  
ELECTRONIC  
APR 16 1981  
*C*

Approved for public release, distribution unlimited.

*A*

AD A 097 834

DTIC FILE COPY

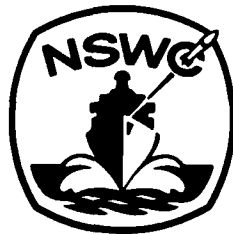

**NAVAL SURFACE WEAPONS CENTER**

Dahlgren, Virginia 22448 • Silver Spring, Maryland 20910

81 4 16 029

UNCLASSIFIED

SECURITY CLASSIFICATION OF THIS PAGE (When Data Entered)

14  
NSWZ  
6

REPORT DOCUMENTATION PAGE		READ INSTRUCTIONS BEFORE COMPLETING FORM
1. REPORT NUMBER NSWZ/R-80-239-PT-1	2. GOVT ACCESSION NO. AD-A097834	3. RECIPIENT'S CATALOG NUMBER 834
4. TITLE (And Subtitle) COMPOSITES FOR ELECTROCHEMICAL TECHNOLOGY PART I. SURVEY OF ELECTRODE CORROSION STUDIES FOR LEAD-ACID BATTERIES		5. TYPE OF REPORT & PERIOD COVERED FY 80
7. AUTHOR(s) 10 I. A. Angres, R33 R. A. Sutula, R32		6. PERFORMING ORG. REPORT NUMBER
9. PERFORMING ORGANIZATION NAME AND ADDRESS Naval Surface Weapons Center White Oak Silver Spring, MD 20910		8. CONTRACT OR GRANT NUMBER(s) 16 F54594
11. CONTROLLING OFFICE NAME AND ADDRESS 12) 24		10. PROGRAM ELEMENT, PROJECT, TASK AREA & WORK UNIT NUMBERS 62761N; SF54-594; SF54-594-594 9R37BC
14. MONITORING AGENCY NAME & ADDRESS (if different from Controlling Office) 9) Technical Repts		12. REPORT DATE 11) SEP 80
16. DISTRIBUTION STATEMENT (of this Report) "Approved for public release; distribution unlimited."		13. NUMBER OF PAGES 24
17. DISTRIBUTION STATEMENT (of the abstract entered in Block 20, if different from Report)		15. SECURITY CLASS. (of this report) Unclassified
18. SUPPLEMENTARY NOTES		15a. DECLASSIFICATION/DOWNGRADING SCHEDULE
19. KEY WORDS (Continue on reverse side if necessary and identify by block number) Corrosion Battery Grid materials Lead-acid batteries Accelerated corrosion Lead Metal Matrix Composites		
20. ABSTRACT (Continue on reverse side if necessary and identify by block number) Corrosion methods used to screen lead electrodes which are potential candidates for use in lead-acid submarine batteries are discussed.		

DD FORM 1 JAN 73 1473

EDITION OF 1 NOV 65 IS OBSOLETE  
S/N 0102-LF-014-6601

UNCLASSIFIED 471563  
SECURITY CLASSIFICATION OF THIS PAGE (When Data Entered)

FOREWORD

This report briefly describes corrosion methods used to screen lead electrodes which are potentially useful for submarine lead acid batteries.

J. R. DIXON  
By direction

Accession For	
NTIS GRA&I	<input checked="" type="checkbox"/>
DTIC TAB	<input type="checkbox"/>
Unannounced	<input type="checkbox"/>
Justification	
By _____	
Distribution/	
Availability Codes	
Avail number	
Dist	Spec 1
A	

ACKNOWLEDGEMENT

This work was supported by Mr. M. Kinna (NAVSEA 62R) through the Metal Matrix Materials Block under the direction of Dr. John V. Foltz. We are particularly indebted to Mr. A. Himy (NAVSEA 543) for his technical advice and suggestions.

CONTENTS

	<u>Page</u>
FOREWORD . . . . .	1
ACKNOWLEDGEMENT . . . . .	2
INTRODUCTION . . . . .	5
CORROSION CONSIDERATIONS . . . . .	6
CONCLUSION . . . . .	13

ILLUSTRATIONS

<u>Figure</u>	<u>Page</u>
1. DIAGRAM OF APPARATUS . . . . .	8
2. DIAGRAM OF APPARATUS FOR INVESTIGATING THE ANODIC CORROSION OF METAL MATRIX MATERIALS . . . . .	11

<u>Table</u>	<u>TABLE</u>	<u>Page</u>
I. POTENTIALS OF VARIOUS ELECTRODES REFERRED TO THE Hg, Hg <sub>2</sub> SO <sub>4</sub> ELECTRODE IN 40.8% H <sub>2</sub> SO <sub>4</sub> AT 20°C . . . . .		9

## INTRODUCTION

This report provides a brief review of corrosion literature to establish a data base on corrosion studies for lead electrodes.

The main storage battery in nuclear submarines is lead-acid, and serves the following purposes:

1. Provides a ready source of standby power capable of sustaining ship or nuclear reactor vital auxiliaries without interruption of service in the event of loss of normal power sources; and
2. In the event of a nuclear reactor scram, it sustains submerged ship operations to re-start the nuclear reactor. This includes providing propulsion, life support, ship and nuclear reactor auxiliary power.

The importance of the main storage battery in maintaining the reliability of the nuclear propulsion plant cannot be overemphasized.

The electrode grids of most lead-acid batteries are made from alloys such as lead-antimony, lead-arsenic, or lead-calcium, that possess better mechanical strength and are easier to handle than pure lead.

Present-day nuclear submarine batteries employ grids made of lead-calcium alloys. However, these grids suffer serious mechanical failure as a result of corrosion. After about 66 months of service, the positive grid of the nuclear submarine battery loses its strength and expands, causing battery failure.

The grid material of choice, from an electrochemical standpoint, is pure lead metal. It is known that pure lead has many desirable properties:

1. High hydrogen overpotential;<sup>1</sup>
2. Avoids adverse electrochemical side effect of alloying ingredients; and
3. Excellent corrosion resistance to sulfuric acid.<sup>2</sup> Pure lead, however, lacks the tensile and creep strength to serve alone as a grid material.

---

1. Hampel, C. A., "The Encyclopedia of Electrochemistry", Reinhold, New York (1964) pg. 869.

2. Perkins, J., Pokorny, J. L., Coyle, M. T., AD-A 032-299 "A Review of Materials and Mechanisms which affect the performance of Lead-Acid Batteries", Oct. 1976.

Exploratory development has shown that metal matrix composite grids made from pure lead reinforced with non-metallic fibers will combine the desirable electrochemical properties of pure lead with the great mechanical strength of the fibers.

Since corrosion studies are used to screen the composite materials for use as grids in lead-acid batteries, a short literature review on corrosion of lead and its electrodes including experimental details are described below.

#### CORROSION CONSIDERATIONS

Lead and its alloys are used in a variety of lead-acid battery designs and applications. Therefore, it is necessary to examine the behavior of a given alloy under the conditions of its prospective use, for example float charge.

Lander was the first to study the anodic corrosion of lead in detail. Combining a thermodynamic and kinetic approach, he related the mechanism of the positive plate reactions to the actual conditions of battery service. Lander's work showed that the grid of the Pb/PbO<sub>2</sub> electrode is passivated at a potential corresponding to mild overcharge; which is encountered in battery-"Float" service. The original work of Lander<sup>3</sup> showed that at constant potentials in the range 0.1 to 1.0 volt, tetragonal PbO is formed in contact with lead in sulfuric acid solutions. An outer layer of PbSO<sub>4</sub> is formed, probably by chemical reaction between H<sub>2</sub>SO<sub>4</sub> and the PbO layer. The corrosion rate in this voltage range increased with increasing temperature and with decreasing acid concentration. The latter effect is explained by showing a linear relation between rate and the square of the activity of water in the electrolyte. At potentials from 1.20 to about 1.50 a protective film is formed, presumably consisting of PbO<sub>2</sub>.

Subsequently, Lander<sup>4</sup> showed that PbO<sub>2</sub> undergoes a solid phase reaction with Pb to form tetragonal PbO. A mechanism involving the Volta effect is proposed. A contact potential between Pb and PbO<sub>2</sub> may be an important part of the cell potential and explain self-discharge and the discharge reaction at the positive plate.

An intermediate film of PbO<sub>2</sub> is formed by the corrosion process which does not cycle completely to PbSO<sub>4</sub>. Because of this, it retains its compact nature and may in large measure be responsible for slowing down grid corrosion.

Grid growth appeared to be proportional to the depth of corrosion after an initial period. The initial period and the rate of growth are probably characteristic of the tensile strength or creep resistance of the metal.

The mechanisms governing rate have not been determined in all the potential ranges concerned; indeed, the whole picture is rather complicated because of the number of reactions occurring. The following reasoning can be ascertained from Lander's work:<sup>5</sup>

3. Lander, J. J., J. Electrochem. Soc., 98, 213 (1951)
4. Lander, J. J., ibid; pg. 98, 220 (1951)
5. Lander, J. J., ibid; pg. 103, 1 (1956)

1. Formation of lead dioxides by the reaction,  $\text{Pb} + 2\text{H}_2\text{O} \rightarrow \text{PbO}_2 + 4\text{H}^+ + 2\text{e}^-$ , is the first step in the corrosion process above the reversible potential for that reaction. It is unstable both on chemical and electrochemical grounds at the lower potentials and goes to lead monoxide and lead sulfate.
2. A voltage limit above which the solid-phase reaction,  $\text{Pb} + \text{PbO}_2 = 2\text{PbO}$ , cannot go has been shown to be about +1.58v to the standard hydrogen electrode. This voltage marks the appearance of lead dioxide in the corrosion product and is characterized by a peak in the corrosion-rate vs potential curve which separates the kinetic behavior of the corrosion processes. At more noble potentials, just below the reversible positive-plate potential, corrosion rates are limited by penetration of the positive-plate-discharge-reaction into an underlying lead dioxide film. This (pretration) is controlled by diffusion of  $\text{SO}_4^{2-}$  through a porous film of mixed lead dioxide and lead sulfate. At slightly less noble potentials, diffusion control gives way to a relatively rapid process because the solid phase reaction begins to take place and the lead dioxide film is attacked from both sides.
3. Above the reversible  $\text{PbO}_2/\text{PbSO}_4$  potential, corrosion rates fall off very rapidly to extremely low values, because a protective lead dioxide film is built up. Rates in this potential range do not vary with potential at room temperature within experimental error, but they do increase with increasing temperature and decreasing acid concentration.

The experimental details of Lander's work are as follows:

Granular lead (purity about 99.97%) was melted in a clean glass beaker, cast into a steel mold, and cold rolled to a thickness of 0.051 cm (0.02 in.) between polished steel rolls. Samples were always cut to the same dimensions giving a total area of 34 cm<sup>2</sup> and were maintained at several constant potentials in sulfuric acid solutions in the range covering about one volt below the reversible potentials for the  $\text{PbO}_2 - \text{PbSO}_4$  couple. The sulfuric acid was used in concentration of 10, 30, and 40 percent by weight, and two constant temperatures: 30° and 50°C were employed. The rates of attack were followed either by stripping the film in ammonium acetate solution and determining weight loss directly or by recording the currents flowing through the samples. By checking measured weight losses against those calculated from Faraday's law, it was established that the law, calculated for the reaction:  $\text{Pb} \rightarrow \text{Pb}^{2+} + 2\text{e}^-$  applies at potentials below those for  $\text{PbO}_2$  formation. X-ray analyses of the film substance were also obtained.

The circuit diagram of the apparatus used for maintaining constant potential is shown in Figure 1. A resistor  $R_1$ , consisting of several feet of copper wire, was connected in series with the variable resistors  $R_3$  and  $R_4$ , so that currents producing potential drops up to 1.1 volts across  $R_1$  could be made to flow. B, the sample to be anodized, was contained in a beaker of sulfuric acid electrolyte, and could be connected to any position on  $R_1$  through  $R_2$ , a two-ohm resistor, from which leads ran to a G.E. potentiometer recorder. A and A' were sections of positive plate from a lead-acid cell, having a capacity such that currents of the magnitude drawn by the samples produced no polarization. They were connected by switches  $S_1$  and  $S_2$  to either end of the slide wire so that a given potential, anodic or cathodic to that of the  $\text{PbO}_2$  plate, could be applied to the sample. C was a mercury-mercurous sulfate reference electrode, the tip of which was kept within 1 mm of the sample. The contribution to the potential by the ohmic resistance

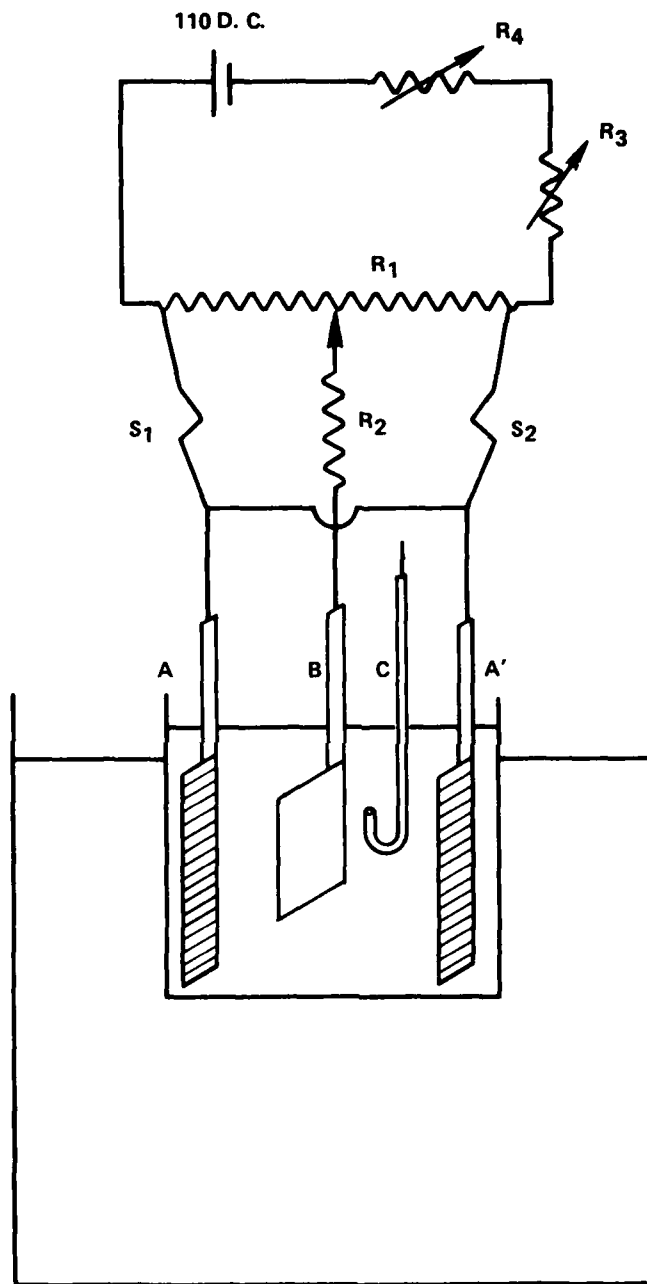
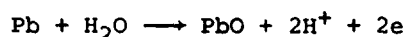

FIGURE 1 DIAGRAM OF APPARATUS

between sample and reference electrode was estimated to be considerably less than 1 mv for a current of 10 ma. The reference electrode and the sample were connected to a Rubicon Null-point potentiometer. The sample potential was adjusted manually by sliding the contact from  $R_2$  along  $R_1$  and by adjusting the resistors  $R_3$  and  $R_4$ . Potentials were controlled to within  $\pm 0.01$  volt and variations within this range did not introduce significant errors. Current-time curves were plotted from the record, and weight-loss vs. time curves were then calculated using small increments of the area under the curve and Faraday's law.

All voltages are referred to the mercury-mercurous sulfate electrode in 40.8 percent sulfuric acid at 20°C, which has a potential of +0.566 to the standard hydrogen electrode. For purposes of orientation the reversible potentials of the several couples under the various experimental conditions with respect to this electrode are given in Table I. Standard potentials are also included. These values were all calculated from the data of Harned and Hamer<sup>6</sup> except for the Pb, PbO, and Pb, Pb(OH)<sub>2</sub> couples for which  $E^\circ$ 's were calculated using the free energy data from Latimer<sup>7</sup> and the other values using the Nernst equation for the reactions:



and

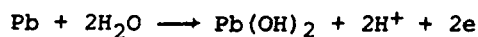

Table I. Potentials of various electrodes referred to the Hg, Hg<sub>2</sub>SO<sub>4</sub> electrode in 40.8% H<sub>2</sub>SO<sub>4</sub> at 20°C

Electrode	$E^\circ$	Concentration of H <sub>2</sub> SO <sub>4</sub>					
		10%		30%		40%	
		30°C	50°C	30°C	50°C	30°C	50°C
PbO <sub>2</sub> , PbSO <sub>4</sub>	+1.685	+1.063	+1.058	+1.135	+1.131	+1.181	+1.177
Hg, Hg <sub>2</sub> SO <sub>4</sub>	+0.615	+0.104	+0.099	+0.038	+0.031	+0.000	-0.004
Pb, PbO	+0.250	-0.348	-0.351	-0.306	-0.306	-0.280	-0.277
Pb, Pb(OH) <sub>2</sub>	+0.242	-0.357	-0.360	-0.312	-0.312	-0.280	-0.277
Pb, PbSO <sub>4</sub>	-0.355	-0.865	-0.873	-0.933	-0.942	-0.970	-0.979

Thomas and Haring<sup>8</sup> established that by static discharge the Pb-Sb alloy sulfates in approximately 1/9 of the time required for pure Pb and 1/10 the time required for the Pb-Ca alloy. They concluded that anodically and cathodically, the behavior of

6. Harned, H. S., and Hamer, W. J., J. Amer. Chem. Soc., 57, 33 (1935)

7. Latimer, W. M., "Oxidation Potentials," pp 304-305, Prentice Hall Inc., NY (1938)

8. Haring, H. E., Thomas, U. B., Trans. Electrochem. Soc., 68, 293 (1935)

the Pb-Ca alloy is similar to that of pure lead but quite distinct from that of the Pb-Sb alloy.

With respect to carbon-reinforced lead electrodes, only preliminary work has been done by Gould, and the results are encouraging.<sup>9</sup> In summary, Gould found that the best results were obtained with the HM/PVA-3000 graphite-fiber composite rods with 15 mil electroplate of lead. The rods completed 75 days on test at 71°C which would be equivalent to 2250 days (6.14 years) at room temperature. The maximum depth of corrosion was found to be three mils.

The apparatus used in these corrosion studies are shown in Figure 2. The constant potential was supplied by a custom-built multistation potentiostatic voltage regulator. A primary reference voltage was provided by a Lambda LCS-2-01 power supply with each individual station provided with a 20 turn pot for fine regulation. The sensing and current leads were separate. The voltage was checked and adjusted as required at 24-hour intervals. The corrosion studies were conducted at 71°C in 1.285 specific gravity sulfuric acid with constant potential of 1.226 v anodic to the mercury-mercurous sulfate electrode.

In comparing Lander's experimental set up and the experimental set up of Gould it is found that the Gould approach provides corrosion data in terms of life-stability at a much more rapid rate than Lander's approach. Lander's approach is closer to the actual corrosion a battery experiences during charge-discharge. However, it appears that a much longer time is needed to get the necessary data for final evaluation of lead composite samples.

The data obtained from the accelerated anodic corrosion studies at 71°C was assumed to follow the Arrhenius equation,

$$\frac{1}{T_1} - \frac{1}{T_2} = K \log \frac{I_2}{I_1} \quad (1)$$

where I represents the rate of any specific chemical process, and extrapolated to 25°C to obtain the service life of the composite electrode. Extrapolation of anodic corrosion data at high temperatures to room temperature must be taken with "a grain of salt." It is possible that at the high temperature the reactions and products may be substantially different than those at 25°C. Without a correlation between the 71 and 25°C temperature data, it is not possible to put any confidence in the values obtained for service life of the electrode. The accelerated anodic corrosion tests at 71°C can be used as a relative method to screen potential fiber reinforced lead composites. Since all electrodes are treated in the same way during the corrosion test, then those electrodes that last the longest would tend to give the longest service life at 25°C. Thus, it is evident that corrosion data at 25 and 35°C must be obtained to determine whether the data obtained from the accelerated anodic corrosion tests at 71°C can be modeled by equation (1) with any confidence in the service life values at 25°C.

---

9. Mao, G. W., Fiedler, A. F., "Feasibility Study for Utilization of Fiber Reinforced Lead Composites in Naval Hardware Applications," Report No. NSWC-76-C-0215-U, 15 November 1977.

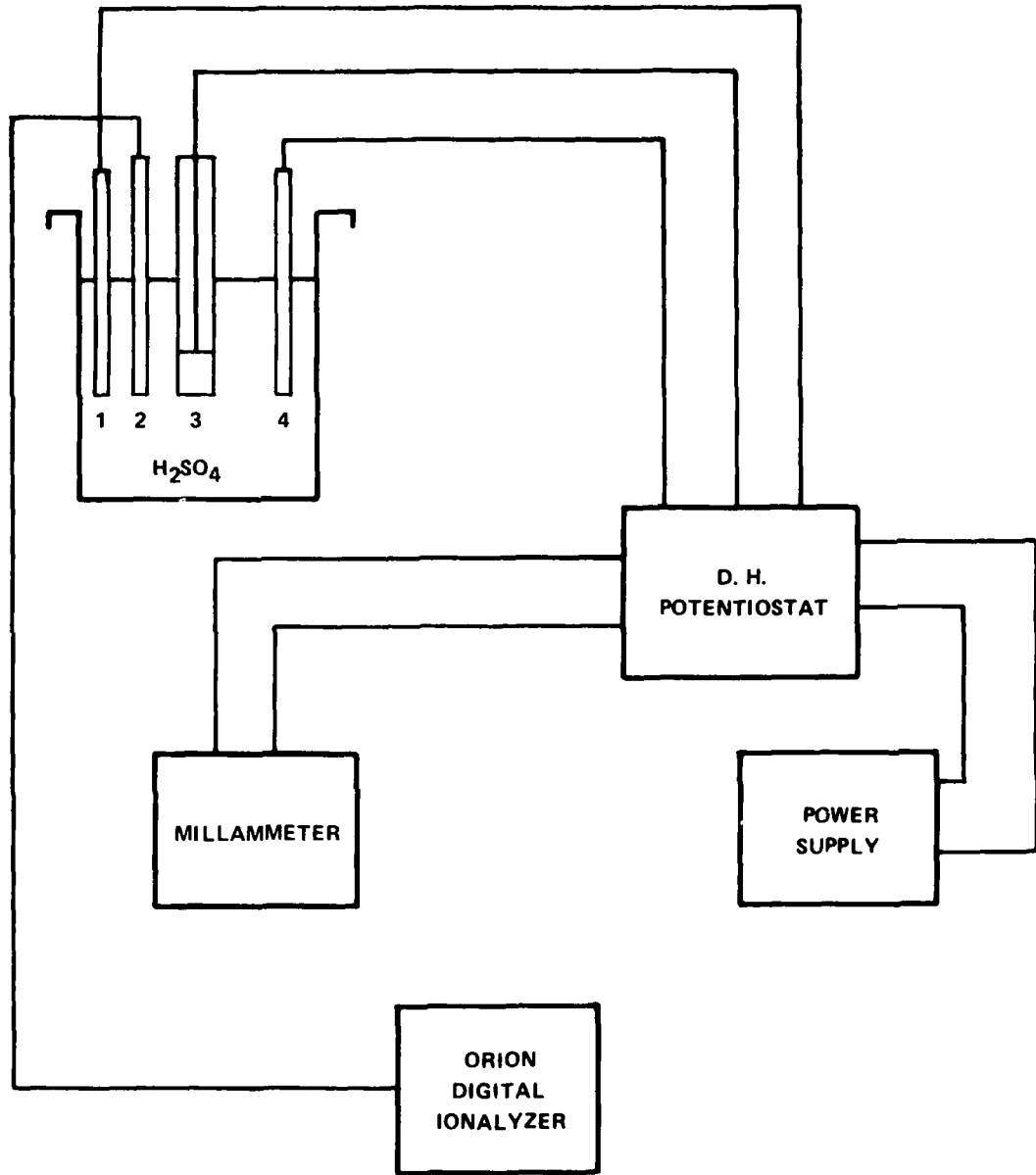

1. WORKING ELECTRODE - Pb/Ca OR LEAD COMPOSITE
2. ION SELECTIVE ELECTRODE
3. REFERENCE ELECTRODE - Hg/Hg<sub>2</sub> SO<sub>4</sub>
4. COUNTER ELECTRODE - Pb

FIGURE 2 DIAGRAM OF APPARATUS FOR INVESTIGATING THE ANODIC CORROSION OF METAL MATRIX MATERIALS

Therefore, using the apparatus of Figure 2 we recommend that accelerated anodic corrosion tests on lead, lead alloys, and fiber reinforced lead composites be performed at 25, 35 and 70°C. By performing the accelerated anodic corrosion test at three temperatures it will be possible to determine what correlation exists between the 70° and 25°C temperature data.

CONCLUSION

Accelerated anodic corrosion tests can be used to evaluate the service life of lead-acid battery electrodes provided a correlation exists between high and room temperature data. Without such a correlation the accelerated anodic corrosion tests can only be used as a relative method to screen potential fiber reinforced lead electrodes.

## DISTRIBUTION

	<u>Copies</u>		<u>Copies</u>
Office of Deputy Under Secretary of Defense for Research and Engineering		Commander Naval Sea Systems Command	
Staff Specialist for Materials and Structures		Attn: Mr. M. Kinna, Code 62R	1
Room 3D1089, The Pentagon		Dr. H. Vanderveldt,	
Attn: Mr. Jerome Persh	1	Code 0352	1
Washington, DC 20301		Mr. G. Sorkin, Code 035	1
		Dr. J. W. Murrin, Code 0331	1
		Mr. A. Himy, Code 5433	1
		Code 09G32	2
		Code 03B	1
		Code 0841B	1
Defense Advanced Research Projects Agency		Washington, DC 20362	
1400 Wilson Blvd.		NETCO	
Attn: Dr. A. Bement	1	2225 E. 28th Street	
Arlington, VA 22209		Attn: Mr. L. Davis	
		Long Beach, CA 90806	1
		Areospace Corporation	
Naval Material Command		Ivan A. Getting Laboratories	
Department of the Navy		300 S. Douglas Street	
Attn: Mr. W. Greenert, MAT 08D	1	Attn: Dr. E. Kendall	1
Mr. W. Holden, MAT 08E4	1	Mr. W. Pfeifer	1
Washington, DC 20360		Mr. W. C. Riley	1
		El Segundo, CA 95085	
Office of Naval Research		Commander	
800 N. Quincy Street		Naval Air Development Center	
Attn: Dr. B. MacDonald, Code 471	1	Attn: Dr. E. McQuillen	1
Dr. G.A. Neece, Code 472	1	Dr. G. London	1
Code 715	1	Warminster, PA 18974	
Arlington, VA 22217		Commander	
		David Taylor Naval Ship	
Naval Research Laboratory		Research and Development	
Attn: Dr. S. C. Sanday, Code 6370	1	Center	
Dr. I. Wolock, Code 8433	1	Attn: Mr. J. Gudas, Code 2813	1
Dr. H. Chaskelis, Code 8431	1	Dr. W. Lukens, Code 2822	1
Dr. A. C. Simon, Code 6130	1	Mr. J. Kelly, Code 2803	1
		Mr. A. B. Neild, Code 2723	1
		Mr. J. Woerner, Code 2724	1
		Annapolis, MD 21402	

## DISTRIBUTION (Cont.)

	<u>Copies</u>		<u>Copies</u>
Commanding Officer Air Force Materials Laboratory Wright-Patterson Air Force Base Attn: Mr. M. Duhl, Code MB	1	LWA Composite Specialties, Inc. 21119 Superior Street Attn: Mr. J. Dolowy	1
Mr. T. Ronald, Code LLS	1	Chatsworth, CA 91311	
Dr. W. S. Bishop, Code POE-1	1	Materials Concepts, Inc. 2747 Harrison Road	
Dr. J. Lander, Code POE-1	1	Attn: Mr. S. Paprocki	1
Dayton, OH 45433		Columbus, OH 43204	
Department of the Army AMMFC Attn: Dr. A. Levitt	1	Material Science Corporation Blue Bell Office Campus	
Mr. J. Greenspan	1	Merion Towle House	
Dr. F. Larson	1	Attn: Dr. E. W. Rosen	1
Watertown, MA 02172		Blue Bell, PA 19422	
NASA/Langley Research Center Attn: E. Mathauser, Code MS188A	1	U.S. Army Research Office Associate Director, Metallurgy and Materials Science Division	
Dr. T. Bales	1	P.O. Box 1221	
Dr. D. Tenney	1	Attn: John C. Hurt	1
Hampton, VA 23365		Triangle Park, NC 27709	
NASA Headquarters 600 Independence Avenue Attn: G. Deutsch	1	Ballistic Missile Defense Officer BMD-ATC	
Washington, DC 20546		P.O. Box 1500	
NASA Lewis Research Center 2100 Brookpark Road Attn: Mr. R. A. Signorelli	1	Attn: M. L. Whitfield	1
Dr. J. S. Fordyce, Code MS309/i	1	Huntsville, AL 35807	
Cleveland, OH 44135		Commanding Officer Air Force Flight Dynamics Laboratory	
Exxon Enterprise, Inc. Project Manager Old Buncombe Road and Poplar Drive Attn: Jack L. Cook	1	Wright-Patterson Air Force Base	
Greer, SC 29651		Attn: G. Foselius	1
		J. Felley	1
		Dayton, OH 45433	

## DISTRIBUTION (Cont.)

	<u>Copies</u>		<u>Copies</u>
SAMSO (YCPC) P.O. Box 92960, LAAFS Worldway Postal Center Attn: LTCOL H. L. Staubs Los Angeles, CA 90009	1	Naval Ordnance Station Project Manager Southside Drive Attn: Howard R. Paul Louisville, KY 40150	1
The Pentagon Project Officer, OSD (MRA&L)-WR Room 2B323 Attn: William G. Miller Washington, DC 20301	1	Department of the Navy Strategic Systems Project Office Crystal Mall No. 3 Attn: G. Needham, Code 273 LCDR F. Ness, Code 234 LCDR H. Nakayama, Code 272 Washington, DC 20362	1 1 1
Johns Hopkins University Applied Physics Laboratory Section Supervisor-Structures Johns Hopkins Road Attn: William Caywood Library Laurel, MD 20810	1 1	AF Weapons Laboratory Kirtland AFB Attn: Charles Stein Albuquerque, NM 87115	1
Lockheed Missile and Space Company, Inc. Bldg. 154 P.O. Box 504 Attn: A. C. Johnson, Dept. 81-22 G. B. Pinkerton, Dept. 81-22 J. T. McGrath, Dept. 81-12 Sunnyvale, CA 95020	1 1 1	Lockheed Missiles & Space Company, Inc. 1111 Lockheed Way Attn: Henry H. Armstrong Sunnyvale, CA 94086  Commander Naval Air Systems Command Attn: Mr. P. Schmidt, Code 52031A Dr. H. Rosenwasser, Code 310C	1
Fiber Materials, Inc. Director, Research & Development Biddeford Industrial Park Attn: Roger I. Pepper Biddeford, ME 04005		Aluminum Company of America Attn: Thomas B. Gurganus Alcoa Center, PA 15069	1

## DISTRIBUTION (Cont.)

	<u>Copies</u>		<u>Copies</u>
Atlantic Research Corporation 5390 Cherokee Avenue Attn: Jerry L. Fields Jay Baetz Alexandria, VA 22314	1 1	Lockheed Corporation P.O. Box 551 Bldg. 61, Dept. 03/10 Attn: M. A. Steinberg Burbank, CA 91520	1
E. I. Du Pont De Nemours & Co. (Inc.) Pioneering Research Division Experimental Station Attn: Ashok K. Dhingra Wilmington, DE 19898	1	Lockheed Missiles and Space Company, Inc. P.O. Box 504 Dept. 62-92, Bldg. 154 Attn: Elliott Willner Sunnyvale, CA 94086	1
AMERCOM 8948 Fullbright Avenue Attn: Robert Fisher Chatsworth, CA 91311	1	Hughes Aircraft Company Blg. 6/MML Sta. D 147 Attn: R. W. Seibold Culver City, CA 90203	1
United Technologies Research Center Attn: Karl M. Prewo East Hartford, CT 06108	1	Air Force Materials Laboratory Nonmetallic Materials Division Attn: R. M. Neff WPAFB, OH 45433	1
Sandia Laboratories Attn: William R. Hoover Livermore, CA 94550	1	The Boeing Vertol Company P.O. Box 16858, P62-06 Attn: R. L. Pickney Philadelphia, PA 19142	1
General Dynamics Convair Division P.O. Box 80847 Attn: N. R. Adsit San Diego, CA 92138	1	AVCO Specialty Materials 2 Industrial Avenue Attn: Paul R. Hoffman Lowell, MA 01851	
Vought Corporation Advanced Technology Center P.O. Box 226144 Attn: R. C. Van Siclen Dallas, TX 75266	1	Pratt and Whitney Aircraft GPD, Mail Stop R-16 Attn: Roy T. Debski West Palm Beach, FL 33410	1

## DISTRIBUTION (Cont.)

	<u>Copies</u>		<u>Copies</u>
Lockheed Missile & Space Company, Inc. P.O. Box 504 Dept. 62-60, Bldg. 104 Attn: Henry Cohan Sunnyvale, CA 94086	1	University of Texas Professor Harris L. Marcus Tay 167 Austin, TX 78712	1
Fiber Materials, Inc. - West 11222 La Genega Blvd. Suite 320 Attn: John Cooney Inglewood, CA 90304	1	Gould, Inc. Program Manager 40 Gould Center Attn: Brian L. Burrows Rolling Meadows, IL 60008	1
Ballistic Missile Defense Materials Program Office Bldg. 131 Army Materials and Mechanics Research Center Attn: Lewis R. Aronin Watertown, MA 02172	1	Office of Naval Research 536 S. Clark Street Attn: Dr. G. Sandoz Chicago, IL 60605	
NAVPRO, Sunnyvale SPL-3123 Lockheed Bldg. 181 Attn: Philip R. Barlow Sunnyvale, CA 94086	1	Defense Documentation Center Cameron Station Alexandria, VA 22314	12
AFML/MB Attn: Davis R. Beeler WPAFB, OH 45433	1	Office of Chief of Naval Operations Operation Evaluation Group Washington, DC 20350	1
Charles Stark Draper Laboratory 555 Technology Square Attn: John Bimshas, MS #27 Cambridge, MA 02139	1	Defense Nuclear Agency Washington, DC 20301	2
		Measurements Technology Inc. 3029 Greer Road Attn: M. F. Duggan Paio Alto, CA 94303	1
		Naval Ocean Systems Center Attn: P. D. Burke, Code 932 San Diego, CA 92152	1

## DISTRIBUTION (Cont.)

	<u>Copies</u>		<u>Copies</u>
Applied Research Laboratory P.O. Box 30 Attn: H. M. Frost State College, PA 16801	1	US Army Electronics Command Attn: D. Linden, Code DRSEL- TL-P Dr. S. Gilman Code DRSEL-TL-P Fort Monmouth, NJ 07703	1  1
ARTECH Corporation 2901 Telestar Ct. Attn: H. Hahn Falls Church, VA 22042	1	Naval Weapons Center Attn: Dr. Aaron Fletcher China Lake, CA 93555	1
Great Lakes Carbon Corporation 299 Park Avenue Attn: W. R. Benn New York, NY 10017	1	Defense Nuclear Agency Attn: Library Washington, DC 20301	1
U.S. Army Mobility Equipment Research and Development Command Attn: G. D. Farmer Jr., Code DRDME EC Fort Belvoir, VA 22060	1	Headquarters, USAFSS Air Force Special Communications Center Attn: Library San Antonio, TX 78243	1
Army Foreign Science and Technology Center 220 7th Street Attn: J. F. Crider, Code FSTC/DRXST-MTI Charlottesville, VA 22901	1	Harry Diamond Laboratory Chief Power Supply Branch Attn: A. A. Benderly Code DRXDO-RDD 2800 Powder Mill Road Adelphi, MD 20783	1
Headquarters, US Army Development & Readiness Command Attn: J. W. Crellin Code DRCDE-L 5001 Eisenhower Avenue Alexandria, VA 22333	1	Naval Intelligence Support Center Attn: Dr. H. E. Ruskie Code 362 4301 Suitland Road Washington, DC 20390	1

## DISTRIBUTION (Cont.)

	<u>Copies</u>		<u>Copies</u>
Naval Material Command		NASA Goddard Space Flight Center	
Attn: I. Jaffe		Attn: G. Halpert	
Code NAVMAT 0323	1	Code 771	1
R. H. Abrams		Greenbelt, MD 20771	
Code NAVMAT 03533	1		
Washington, DC 20360		Headquarters, Dept. of Transportation	
		Attn: R. Potter	
Naval Underwater Systems Center		Code GEOE-3/61	1
Attn: T. Black		US Coast Guard, Ocean Engineering	
Code 3642	1	Division	
Newport, RI 02840		Washington DC 20590	
		Edgewood Arsenal	
Naval Undersea Center		Attn: Library	1
Attn: Library		Aberdeen Proving Ground, MD 21010	
Code 6565	1		
San Diego, CA 92132		Naval Electronics Systems Command	
		Attn: A. H. Sobel, Code PME 124-31	1
Naval Weapons Support Center		Washington, DC 20360	
Electrochemical Power Sources			
Division		EPRI	
Attn: D. G. Miley		Battery Technology	
Code 305	1	Attn: D. L. Douglas	
Crane, IN 47522		3412 Hillview Avenue	
		P. O. Box 10412	
Department of Energy		Palo Alto, CA 94303	
Division of Electric Energy Systems			
Attn: L. J. Rodgers		J.P.L.	
Room 2101	1	California Institute of Technology	
Washington, DC 20545		Attn: Dr. D. B. Edwards	1
		Mr. W. E. Rippel	1
Department of Energy		4800 Oak Grove Drive	
Division of Applied Technology		Pasadena, CA 91103	
Attn: Dr. A. Landrebe			
Code M/S E-463	1		
Washington, DC 20545			
Strategic Systems Project Office			
Engineering Development Project Office			
Attn: K. N. Boyley			
Code NSP-2721	1		
Washington, DC 20360			

TO AID IN UPDATING THE DISTRIBUTION LIST  
FOR NAVAL SURFACE WEAPONS CENTER, WHITE  
OAK LABORATORY TECHNICAL REPORTS PLEASE  
COMPLETE THE FORM BELOW:

TO ALL HOLDERS OF NSWC/TR 80-239  
by I. A. Angres, Code R32  
DO NOT RETURN THIS FORM IF ALL INFORMATION IS CURRENT

---

A. FACILITY NAME AND ADDRESS (OLD) (Show Zip Code)

---

NEW ADDRESS (Show Zip Code)

---

B. ATTENTION LINE ADDRESSES:

---

C.

REMOVE THIS FACILITY FROM THE DISTRIBUTION LIST FOR TECHNICAL REPORTS ON THIS SUBJECT.

---

D. NUMBER OF COPIES DESIRED \_\_\_\_\_

**DEPARTMENT OF THE NAVY  
NAVAL SURFACE WEAPONS CENTER  
WHITE OAK, SILVER SPRING, MD. 20910**

**OFFICIAL BUSINESS  
PENALTY FOR PRIVATE USE, \$300**

**POSTAGE AND FEES PAID  
DEPARTMENT OF THE NAVY  
DOD 316**



**COMMANDER  
NAVAL SURFACE WEAPONS CENTER  
WHITE OAK, SILVER SPRING, MARYLAND 20910**

**ATTENTION: CODE R32**

FILMED

— 8