

MICROCOPY RESOLUTION TEST CHART
NATIONAL BUREAU OF STANDARDS 1963-A

LEVEL II

12

B.S



AD A 098180

**DEPARTMENT OF DEFENCE
DEFENCE SCIENCE AND TECHNOLOGY ORGANISATION
AERONAUTICAL RESEARCH LABORATORIES**

MELBOURNE, VICTORIA

AERODYNAMICS NOTE 400

**DTIC
ELECTE
APR 30 1981
S D
E**

**TRANSONIC WIND TUNNEL MEASUREMENTS OF
TAILPLANE AND ELEVATOR EFFECTIVENESS OF THE
JINDIVIK 203B TARGET AIRCRAFT**

by

B. D. FAIRLIE

Approved for Public Release.



THE UNITED STATES NATIONAL
TECHNICAL INFORMATION SERVICE
IS AUTHORISED TO
REPRODUCE AND SELL THIS REPORT

© COMMONWEALTH OF AUSTRALIA 1980

DTIC FILE COPY

COPY No 15

SEPTEMBER 1980

81 4 30 011

DEPARTMENT OF DEFENCE
DEFENCE SCIENCE AND TECHNOLOGY ORGANISATION
AERONAUTICAL RESEARCH LABORATORIES

14 ARL/AERO NOTE-400

AERODYNAMICS NOTE 400

6
**TRANSONIC WIND TUNNEL MEASUREMENTS OF
TAILPLANE AND ELEVATOR EFFECTIVENESS OF THE
JINDIVIK 203B TARGET AIRCRAFT**

12 74

by

1
B. D/FAIRLIE

11 Sep 80

SUMMARY

Measurements of tailplane and elevator effectiveness are reported for a 1/20th scale complete model of the Jindivik target aircraft. The model reflected the Mk.203B version of the full scale aircraft, the major features of which are as follows: short wing with Mk.8 fuel pods (with fins), nominal $+1^\circ$ twisted flap, fixed ailerons drooped at $1\frac{1}{2}^\circ$; extended chord tailplane with a nominal setting of -1° . The tests included tailplane angles in the range $-2\frac{1}{2}^\circ$ to $3\frac{1}{2}^\circ$ and elevator angles in the range -15° to 10° for Mach numbers between 0.5 and 0.9. The aircraft is shown to be generally stable throughout the tested ranges, but several small areas of instability are noted. Tailplane and elevator angles to trim are also included and both are shown to increase rapidly for Mach numbers above 0.75.

POSTAL ADDRESS: Chief Superintendent, Aeronautical Research Laboratories,
Box 4331, P.O., Melbourne, Victoria, 3001, Australia.

008650

DOCUMENT CONTROL DATA SHEET

Security classification of this page: Unclassified

- | | |
|--|--|
| <p>1. Document Numbers</p> <p>(a) AR Number:
AR-002-230</p> <p>(b) Document Series and Number:
Aerodynamics Note 400</p> <p>(c) Report Number:
ARL-Aero-Note-400</p> | <p>2. Security Classification</p> <p>(a) Complete document:
Unclassified</p> <p>(b) Title in isolation:
Unclassified</p> <p>(c) Summary in isolation:
Unclassified</p> |
|--|--|

3. Title: **TRANSONIC WIND TUNNEL MEASUREMENTS OF TAILPLANE AND ELEVATOR EFFECTIVENESS OF THE JINDIVIK TARGET AIRCRAFT**

- | | |
|---|--|
| <p>4. Personal Author:
Fairlie, B. D.</p> | <p>5. Document Date:
September, 1980</p> |
| <p>6. Type of Report and Period Covered:</p> | |

- | | |
|--|--|
| <p>7. Corporate Author:
Aeronautical Research Laboratories</p> | <p>8. Reference Numbers</p> <p>(a) Task:</p> |
| <p>9. Cost Code:
54 7710</p> | <p>(b) Sponsoring Agency:</p> |

- | | |
|---|--|
| <p>10. Imprint:
Aeronautical Research Laboratories,
Melbourne</p> | <p>11. Computer Program(s)
(Title(s) and language(s)):</p> |
|---|--|

12. Release Limitations (of the document):
Approved for Public Release

12.0 Overseas:	N.O.		P.R.	1	A		B		C		D		E	
----------------	------	--	------	---	---	--	---	--	---	--	---	--	---	--

13. Announcement Limitations (of the information on this page):
No Limitations

- | | | |
|--|--|-----------------------------------|
| <p>14. Descriptors:
Transonic wind tunnels
Jindivik target aircraft
Aerodynamic stability
Pitching</p> | <p>Target drone aircraft
Elevators (control surfaces)
Horizontal tail surfaces</p> | <p>15. Cosati Codes:
0101</p> |
|--|--|-----------------------------------|

16. **ABSTRACT**
Measurements of tailplane and elevator effectiveness are reported for a 1/20th scale complete model of the Jindivik target aircraft. The model reflected the Mk.203B version of the full scale aircraft, the major features of which are as follows: short wing with Mk.8 fuel pods (with fins), nominal +1° twisted flap, fixed ailerons drooped at 1½°, extended chord tailplane with a nominal setting of -½°. The tests included tailplane angles in the range -2½° to 3½° and elevator angles in the range -15° to 10° for Mach numbers between 0.5 and 0.9. The aircraft is shown to be generally stable throughout the tested ranges, but several small areas of instability are noted. Tailplane and elevator angles to trim are also included and both are shown to increase rapidly for Mach numbers above 0.75.

CONTENTS

Page No.

NOTATIONS

1. INTRODUCTION	1
2. TEST DETAILS	1
2.1 Model	1
2.2 Wind Tunnel	1
2.3 Test Programme	2
3. RESULTS AND DISCUSSION	2
4. CONCLUSIONS	3

REFERENCES

TABLE 1: Main Dimensions of Model and Full Scale Aircraft

NOTATION FOR TABLES 2, 3 and 4

INDEX TO TABLES 2, 3 and 4

TABLES 2, 3 and 4: Tabulated Results

FIGURES

DISTRIBUTION

Accession For	
NTIS GRA&I	<input checked="" type="checkbox"/>
DTIC TAB	<input type="checkbox"/>
Unannounced	<input type="checkbox"/>
Justification	
By _____	
Distribution/	
Availability Codes	
Dist	Avail and/or Special
A	

NOTATION

a_1	Tailplane effectiveness = $\partial C_{LT}/\partial \alpha_T = \partial C_{LT}/\partial \eta_T$
a_2	Elevator effectiveness = $\partial C_{LT}/\partial \eta$
b	Model nominal wingspan = 11.40 in (289.56 mm)
C_C	Cross wind force coefficient = Cross wind force/ $\frac{1}{2}\rho v^2 S$
C_D	Drag force coefficient = Drag force/ $\frac{1}{2}\rho v^2 S$
C_L	Lift force coefficient = Lift force/ $\frac{1}{2}\rho v^2 S$
C_{LT}	Tailplane lift force coefficient = Tailplane lift force/ $\frac{1}{2}\rho v^2 S_T$
C_X	Axial force coefficient = Axial force/ $\frac{1}{2}\rho v^2 S$
C_{XB}	Base force coefficient = $(p_B - p)S_B/\frac{1}{2}\rho v^2 S$
C_Y	Side force coefficient = Side force/ $\frac{1}{2}\rho v^2 S$
C_Z	Normal force coefficient = Normal force/ $\frac{1}{2}\rho v^2 S$
C_l	Rolling moment coefficient = Rolling moment about centre of gravity/ $\frac{1}{2}\rho v^2 S b$
C_m	Pitching moment coefficient = Pitching moment about centre of gravity/ $\frac{1}{2}\rho v^2 S c$
C_n	Yawing moment coefficient = Yawing moment about centre of gravity/ $\frac{1}{2}\rho v^2 S b$
c	Model wing chord = 2.40 in. (60.96 mm)
l	Distance from model centre of gravity to 25% tailplane chord = 5.78 in (146.8 mm)
M	Free stream Mach number
p	Free stream static pressure
p_B	Model base pressure
R	Reynolds number based on model wing chord
S	Model nominal wing area = 27.36 in ² (17651 mm ²)
S_B	Model base area = 0.83 in ² (535.5 mm ²)
S_T	Model nominal tailplane area = 5.265 in ² (3396 mm ²)
V	Tail volume ratio = $S_T l / S c = 0.463$
v	Free stream velocity
α	Angle of incidence: the angle between the wind vector and its projection in the chordal plane.
α_1	Alternative angle of incidence: the angle between the model axis and the projection of the wind vector on the model plane of symmetry.
α_T	Tailplane angle of incidence.
β	Angle of sideslip: the angle between the wind vector and its projection on the model plane of symmetry.
η	Elevator angle with respect to tail plane chord.
$\bar{\eta}$	Elevator angle to trim ($C_m = 0$)

- η_T Tailplane angle with respect to fuselage reference line.
 $\bar{\eta}_T$ Tailplane angle to trim ($C_m = 0$)
 ρ Free stream density.
 ϕ Model roll angle.

Notes:

- (i) See Figure 1 for sign conventions for forces and moments and attitude angles.
- (ii) The nominal aircraft centre of gravity was taken to be located at 0.2 c and 0.1125 in. (2.8575 mm) (model scale) below the fuselage reference line.
- (iii) Since the full scale aircraft and the model were both manufactured before the introduction of *SI* units, all dimensions have been expressed in feet and inches, with the equivalent *SI* unit following in brackets where appropriate.

1. INTRODUCTION

In 1976 a decision was made to update the data available from wind tunnel tests covering the high speed flight envelope of the Jindivik target aircraft. This update became necessary because of the considerable changes to the basic aircraft configuration, which had occurred since the last major series of tests in the period 1956 to 1965.¹⁻⁹ These included changes to control surfaces, pods and pod fins, and to payloads carried. A new test programme was therefore implemented on an existing 1/20th scale complete model of the Jindivik which had been modified to reflect the current full scale aircraft configuration. These tests¹⁰ covered the lateral and longitudinal stability of the aircraft and the effect on stability of various combinations of Tonic towed targets and their mounting beams.

The present tests complement and extend the 1976 tests, being concerned with tailplane and elevator effectiveness. The only previous similar tests were performed in 1962^{2,3} and were made using a half model of the aircraft. Since that time however, the tailplane and elevator chords have been increased so that none of the available data is pertinent to the current aircraft configuration.

The present tests were conducted in the transonic wind tunnel of the Aeronautical Research Laboratories during July and August 1979.

2. TEST DETAILS

2.1 Model

The model used for these tests was a 1/20th scale complete metal model of the Jindivik aircraft modified to reflect the Mk.203B version of the full-scale aircraft. The major features of the configuration are as follows: short wing with Mk.8 fuel pods (with fins), nominal $+1^\circ$ twisted flap, fixed aileron drooped at $+1\frac{1}{2}^\circ$. No intake ducting was represented and an unfaired landing skid was represented in the stowed position. The major dimensions of the model and full-scale aircraft are given in Table 1. A sketch of the aircraft is presented in Figure 2 and a photograph of the model in Figure 3.

Due to the small size of the model, the elevator could not be hinged and changes to tailplane angle (η_T) and elevator angle (η) were obtained by removing the tailplane from its mounting block and remounting at the desired angle. Several tailplanes were available and the required elevator angles were obtained by bending at the elevator hinge line.

Owing to the low Reynolds number of the tests (approximately 0.45×10^6), boundary layer transition was fixed on all windswept surfaces by bands of distributed roughness. These roughness bands were placed on the upper and lower surfaces of the wing and tailplane, on both sides of the fin and pod fins, and on the pods and fuselage. They consisted of approximately 3 mm wide bands of carborundum particles, with a particle diameter of 0.15 mm and a coverage of 10-20%.

2.2 Wind Tunnel

The tests were conducted in the transonic wind tunnel of these laboratories. The nominal dimensions of the test section are 0.81 m by 0.53 m. For these tests, all test section walls were longitudinally slotted (see Fig. 4) with an open area ratio at the model location of 10.5%.

The maximum frontal cross-sectional area of the model at zero incidence was 5.36 in.² (3458 mm²) giving a blockage ratio of 0.81%, and since the ranges of angle of incidence and Mach number of the tests were limited, no tunnel interference corrections were applied to the results.

Mach number and dynamic pressure were derived from measurements of the static pressure in the plenum chamber surrounding the test section and of the static pressure in the contraction entry, assuming these to be the static and total pressures respectively of the test section flow.

2.3 Test Programme

Six-component force and moment coefficients were measured for a range of Mach number $0.50 \leq M \leq 0.90$ in eight steps. The tests covered seven tailplane angles in the range $-2\frac{1}{2}^\circ \leq \eta_T \leq 3\frac{1}{2}^\circ$ (for $-3^\circ \leq \alpha \leq 7^\circ$, $\beta = 0^\circ$, $\eta = 0^\circ$) and six elevator angles in the range $-15^\circ \leq \eta \leq 10^\circ$ (for $0^\circ \leq \alpha \leq 6^\circ$, $\beta = 0$, $\eta_T = \frac{1}{2}^\circ$). In addition tests were conducted with the tailplane removed for $-3^\circ \leq \alpha \leq 7^\circ$ ($\beta = 0^\circ$) at Mach numbers of 0.5, 0.8 and 0.9. Throughout the tests, model altitude was corrected for sting and balance deflection under load.

Test results are tabulated in Tables 2, 3 and 4. Tailplane and elevator angles referred to in these tabulations and elsewhere in this report are nominal angles: the corresponding measured angles are given below.

Nominal		Measured		Nominal		Measured	
η_T	η	η_T	η	η	η_T	η	η_T
$-2\frac{1}{2}^\circ$	0°	-2.52°	0.00°	-15°	$\frac{1}{2}^\circ$	-17.45°	0.50°
$-1\frac{1}{2}^\circ$	0°	-1.42°	0.00°	-10°	$\frac{1}{2}^\circ$	-10.25°	0.50°
$-\frac{1}{2}^\circ$	0°	-0.50°	0.00°	-5°	$\frac{1}{2}^\circ$	-4.50°	0.50°
$\frac{1}{2}^\circ$	0°	0.50°	0.00°	0°	$\frac{1}{2}^\circ$	0.00°	0.51°
$1\frac{1}{2}^\circ$	0°	1.78°	0.00°	5°	$\frac{1}{2}^\circ$	5.50°	0.52°
$2\frac{1}{2}^\circ$	0°	2.68°	0.00°	10°	$\frac{1}{2}^\circ$	10.25°	0.44°
$3\frac{1}{2}^\circ$	0°	3.90°	0.00°				

Measurement accuracy for the above angles was $\pm 0.02^\circ$ for η_T and $\pm 0.05^\circ$ for η .

For all tests, the Reynolds number (based on wing chord) was kept approximately constant at $0.45 \pm 0.03 \times 10^6$ by varying tunnel pressure.

3. RESULTS AND DISCUSSION

The data are plotted in the form of lift coefficient versus angle of incidence in Figure 5 for the various nominal tailplane angles, in Figure 6 for the various nominal elevator angles and in Figure 7 for the case with the tailplane removed. From Figures 5 and 6 it is seen that as expected the effect of variations of tailplane and elevator angles on the overall lift coefficient is small.

In Figure 8 pitching moment coefficient is plotted against angle of incidence for the various tailplane angles. For the current standard tailplane setting ($\eta_T = -\frac{1}{2}^\circ$, $\eta = 0^\circ$) the aircraft is seen to be stable for all Mach numbers tested for angles of incidence less than about 7° , apart from an area around $\alpha = 6^\circ$ for $M = 0.80$. The aircraft is also seen to be stable at all other values of tailplane angle tested except for a region of instability at Mach numbers greater than 0.86 and angles of incidence greater than 7° for a tailplane angle of $3\frac{1}{2}^\circ$.

The same variables are plotted in Figure 9 for the various elevator angles. Once again the curves show general stability throughout the tested range except at an elevator angle of 10° where instability occurs for Mach numbers greater than 0.80 and angles of incidence greater than about 2° . This unstable area extends into the data for an elevator angle of 5° but is limited to higher Mach numbers and angles of incidence.

Figure 10 presents the same variables for the case with the tailplane removed. As found in previous tests¹⁰, the aircraft without tailplane is generally unstable, but with an area of stability at $M = 0.9$ at low incidence.

The variation of pitching moment coefficient with tailplane angle is presented in Figure 11 for constant angles of incidence ($\alpha = 0^\circ, 2^\circ, 4^\circ$). The curves are seen to be generally linear

except at Mach numbers greater than 0.84 for positive values of η_T . There is also evidence of tailplane stalling at Mach numbers above 0.86 for $\alpha = 4^\circ$.

Figure 12 presents the variation of pitching moment coefficient with elevator angle. Once again the curves are generally linear at least for small elevator deflections ($-10^\circ < \eta < 5^\circ$). Tailplane stalling is evident for Mach number greater than 0.7 at large negative elevator angles ($\eta \leq -10^\circ$) for all incidences, and becoming increasingly evident at higher Mach numbers and positive elevator angles as incidence increases.

From Figures 11 and 12, values of tailplane angle and elevator angle to trim were obtained from the intersection of the curves with the horizontal axis ($C_m = 0$). These values are plotted against Mach number in Figures 13 and 14, for different values of incidence. It may be seen that as the Mach number approaches 0.8 the angle required for both elevator and tailplane to trim out the pitching moment increases rapidly. However for angles of incidence up to 4° , an η_T of -4° is sufficient to trim out the pitching moment up to a Mach number of 0.9, or for $\eta_T = \frac{1}{2}^\circ$, an elevator angle of -9° is sufficient.

Values of tailplane and elevator effectiveness have also been obtained from Figures 11 and 12 from the relationships:

$$\begin{aligned} a_1 &= \frac{\partial C_{LT}}{\partial \alpha_T} = \frac{\partial C_{LT}}{\partial \eta_T} \\ &= \frac{\partial C_m}{\partial \eta_T} V \end{aligned}$$

and

$$\begin{aligned} a_2 &= \frac{\partial C_{LT}}{\partial \eta} \\ &= \frac{\partial C_m}{\partial \eta} V \end{aligned}$$

where V is the tail volume ratio ($S_T/l/S_C$).

In both cases, the slopes of the pitching moment curves have been obtained from the linear portions of the curves of Figures 11 and 12. Values of tailplane and elevator effectiveness are plotted against Mach number in Figures 15 and 16.

4. CONCLUSIONS

Transonic wind tunnel tests have been carried out on a 1/20th scale complete model Jindivik 203B to determine tailplane and elevator effectiveness. The tests covered tailplane angles between $-2\frac{1}{2}^\circ$ and $3\frac{1}{2}^\circ$ and elevator angles between -15° and 10° for Mach numbers from 0.5 to 0.9.

The tests indicate that the aircraft is generally stable throughout the range of tailplane and elevator angles tested, although several small areas of instability were discovered and have been noted.

Curves of tailplane and elevator effectiveness and tailplane and elevator angles to trim have been extracted from the data. The latter curves indicate that both tailplane and elevator angle to trim increase rapidly above a Mach number of 0.75. The present elevator size should however be sufficient to trim the aircraft for Mach numbers up to 0.9.

REFERENCES

1. Bennett, A. S. The effect of externally mounted F. H. Sources on the longitudinal stability and drag of a Jiniivik target aircraft. Aeronautical Research Laboratories, Tech. Note, Aero. 183, 1960.
2. O'Brien, L. F. Lift, pitching moment and drag measurements on a half model Jindivik target aircraft. Part I—4° Flap. Aeronautical Research Laboratories, Tech. Note, Aero. 192, 1962.
3. O'Brien, L. F. Lift, pitching moment and drag measurements on a half model Jindivik target aircraft. Part II—20° Flap. Aeronautical Research Laboratories, Tech. Note, Aero. 193, 1962.
4. Bennett, A. S. The effect of rocket fuel pods on the longitudinal stability and drag of Jindivik target aircraft. Aeronautical Research Laboratories, Tech. Note, Aero. 199, 1962.
5. Bennett, A. S. Transonic wind tunnel measurements of the longitudinal and lateral stability of a 1/20th scale Jindivik IIB/III target aircraft. Aeronautical Research Laboratories, Tech. Note, Aero. 195, 1962.
6. O'Brien, L. F. Longitudinal characteristics of an extended tapered wing version of the Jindivik target aircraft. Aeronautical Research Laboratories, Tech. Note, Aero. 253, 1965.
7. Bennett, A. S. Effect of an air brake on the high speed longitudinal stability and drag of Jindivik. Aeronautical Research Laboratories, Tech. Note, Aero. 255, 1966.
8. O'Brien, L. F. Force measurements on the short span Jindivik aircraft fitted with MKVI Pod. Aeronautical Research Laboratories, Tech. Note, Aero. 264, 1966.
9. O'Brien, L. F. Effect of MK VII Ampor pod end shape on Jindivik. Aeronautical Research Laboratories, Tech. Note, Aero. 265, 1966.
10. Fairlie, B. D. Transonic Wind tunnel tests on the Jindivik 203B target aircraft. Aeronautical Research Laboratories, Tech. Note, Aero. 369, 1977.

TABLE 1
Main Dimensions of Model and Full Scale Aircraft

	Model Scale	Full Scale
(1) Wing		
Chord	2.40 in.	48.00 in.
Span (nominal)	11.40 in.	228.00 in.
To centreline of pods	11.82 in.	236.48 in.
Gross wing area	27.36 in. ²	76.0 ft. ²
Wing section	NACA 64-106 (modified)	
Aspect ratio	4.75	
Taper ratio	1.0	
Leading edge sweep	0°	
Trailing edge sweep	0°	
Dihedral	2.5°	
Incidence relative to F.R.L.	1.0°	
(2) Flaps		
Chord	0.60 in.	12.00 in.
Span (per side)	3.45 in.	68.95 in.
Area (per side)	2.07 in. ²	827.4 in. ²
Distance from inboard end to aircraft datum	0.79 in.	15.75 in.
Neutral Setting		
Inboard		+2°
Outboard		0°
Nominal setting		+1°
(3) Ailerons		
Chord	0.60 in.	12.00 in.
Span (per side)	1.35 in.	27.00 in.
Area (per side)	0.81 in. ²	324.0 in. ²
Distance from inboard end to aircraft datum	4.25 in.	84.96 in.
Neutral setting		0°
(4) Mk.8 Pods		
Overall length	7.22 in.	144.33 in.
Diameter	0.625 in.	12.50 in.
Distance from pod centreline to F.R.L.	5.91 in.	118.24 in.
Distance from pod nose to 25% wing chord	3.70 in.	74.09 in.
(5) Pod Fins		
Distance from pod nose to fin trailing edge	6.25 in.	125.00 in.
Root chord	1.20 in.	24.00 in.
Tip chord	0.60 in.	12.00 in.
Maximum height above pod centreline	0.91 in.	18.25 in.
Angle between fin and F.R.L.		25°
Aerofoil section	NACA 64-008 (modified)	
(6) Tailplane		
Chord	1.35 in.	27.00 in.
Span	3.90 in.	78.00 in.
Gross area	5.265 in. ²	2106.0 in. ²
Aspect ratio	2.89	
Taper ratio	1.0	
Sweep at quarter chord	0°	
Incidence relative to F.R.L.	-1°	-0°27'
Aerofoil section	NACA 64-006	

TABLE 1 (Continued)

Main Dimensions of Model and Full Scale Aircraft

	Model Scale	Full Scale
(7) Elevators		
Chord	0.45 in.	9.00 in.
Span (per side)	1.63 in.	32.64 in.
Area (per side)	0.73 in. ²	293.4 in. ²
Distance from inboard end to F.R.L.	0.28 in.	5.55 in.
(8) Fin		
Maximum height above F.R.L.	2.64 in.	52.80 in.
Gross area above tailplane chord	2.35 in. ²	938.9 in. ²
Sweep back of leading edge		14½°
Sweep back of trailing edge		0°
Tip chord	1.20 in.	24.00 in.
Root chord	1.60 in.	32.00 in.
Aerofoil section	NACA 64-006 (modified)	
(9) Fuselage		
Overall length (excluding pitot probe)	13.99 in.	279.75 in.
Maximum height excluding skid beam	1.90 in.	38.04 in.
Maximum width	1.65 in.	33.00 in.
Distance of 25° wing chord aft of STN 'O'	6.61 in.	132.25 in.
Distance of 25° wing chord below F.R.L.	0.41 in.	8.25 in.
Distance of 25° tailplane chord aft of STN 'O'	12.27 in.	245.45 in.
Distance of 25° tailplane chord above F.R.L.	0.86 in.	17.24 in.
Distance of fin trailing edge aft of STN 'O'	13.17 in.	263.37 in.

The following notation refers to the computer generated data listings in Tables 2-4. Where appropriate, the corresponding notation from the main body of the note is also included

Table 2 Notation	Main Body Notation	Explanation
SER	—	Serial number
REYN	R	Reynold's number
MACH	M	Free stream Mach number
INCID.	α	Angle of incidence
LIFT.	C_L	Lift coefficient
PITCH	C_m	Pitching moment coefficient
DRAG	C_D	Drag force coefficient
NORMAL	C_z	Normal force coefficient
AXIAL	C_x	Axial force coefficient
CLSQ.	C_L^2	Lift coefficient squared
BASE	C_{XB}	Base force coefficient
AINC	α_1	Alternative angle of incidence
SLIP	β	Angle of sideslip
CROSS	C_c	Cross wind force coefficient
YAW M.	C_n	Yawing moment coefficient
ROLL M.	C_l	Rolling moment coefficient
RANG	ϕ	Roll angle
SIDE F	C_Y	Side force coefficient

INDEX TO TABLES 2, 3 and 4

Table No.	ηT	η	α
2A	$-2\frac{1}{2}^\circ$	0°	-3° to 7°
2B	$-1\frac{1}{2}^\circ$	0°	-3° to 7°
2C	$-\frac{1}{2}^\circ$	0°	-3° to 7°
2D	$\frac{1}{2}^\circ$	0°	-3° to 7°
2E	$1\frac{1}{2}^\circ$	0°	-3° to 7°
2F	$2\frac{1}{2}^\circ$	0°	-3° to 7°
2G	$3\frac{1}{2}^\circ$	0°	-3° to 7°
3A	$\frac{1}{2}^\circ$	-15°	0° to 6°
3B	$\frac{1}{2}^\circ$	-10°	0° to 6°
3C	$\frac{1}{2}^\circ$	-5°	0° to 6°
3D	$\frac{1}{2}^\circ$	0°	-3° to 7°
3E	$\frac{1}{2}^\circ$	5°	0° to 6°
3F	$\frac{1}{2}^\circ$	10°	0° to 6°
4	Tailplane Off		-3° to 7°

TABLE 2(A)
CLEAN AIRCRAFT
ETA = 0° ETRACT) = -2 1/2°

SER	REYN.	MACH.	INCJD.	LIFT.	PITCH.	DRAW	NORMAL	AXIAL.	CLSQ.	BASE.	RINC.	SLIP.	CROSS.	YAW M.	ROLL M	RANG.	SIDE
003	0.449	0.900	07.45	0.8454	-0.0769	0.1669	-0.8600	-0.0538	0.7147	0.0021	07.45	(0.00	-0.0043	-0.0009	-0.0005	179.9	0.00
004	0.449	0.901	06.93	0.8119	-0.0738	0.1541	-0.8247	-0.0527	0.6592	0.0023	06.93	(0.00	-0.0044	-0.0010	-0.0006	179.9	0.00
005	0.447	0.900	06.41	0.7688	-0.0674	0.1411	-0.7799	-0.0522	0.5910	0.0022	06.41	(0.00	-0.0041	-0.0010	-0.0014	179.9	0.00
006	0.449	0.901	05.89	0.7318	-0.0611	0.1295	-0.7413	-0.0514	0.5354	0.0022	05.89	(0.00	-0.0044	-0.0009	-0.0008	179.9	0.00
007	0.449	0.900	05.38	0.6921	-0.0510	0.1188	-0.7003	-0.0513	0.4788	0.0022	05.38	(0.00	-0.0048	-0.0011	-0.0007	179.9	0.00
008	0.449	0.900	04.34	0.6119	-0.0380	0.1002	-0.6178	-0.0515	0.3743	0.0021	04.34	(0.00	-0.0044	-0.0007	0.0005	180.0	0.00
009	0.449	0.900	03.29	0.5187	-0.0283	0.0847	-0.5228	-0.0527	0.2689	0.0021	03.29	(0.00	-0.0024	-0.0005	0.0010	180.0	0.00
010	0.449	0.900	01.17	0.2946	-0.0100	0.0611	-0.2959	-0.0531	0.0867	0.0020	01.17	(0.01	-0.0006	0.0004	0.0015	180.0	0.00
011	0.449	0.901	-00.96	0.0304	0.0221	0.0510	-0.0296	-0.0496	0.0009	0.0019	-00.96	(0.01	0.0014	0.0006	0.0016	180.0	-0.00
012	0.449	0.902	-03.10	-0.2673	0.0708	0.0616	0.2702	-0.0455	0.0713	0.0016	-03.10	(0.01	0.0030	0.0005	0.0018	180.0	-0.00
015	0.457	0.880	07.48	0.8130	-0.0276	0.1572	-0.8267	-0.0481	0.6609	0.0019	07.48	(0.01	-0.0050	-0.0004	0.0017	180.0	0.00
016	0.453	0.880	06.94	0.8049	-0.0633	0.1486	-0.8171	-0.0485	0.6478	0.0018	06.94	(0.00	-0.0051	-0.0009	-0.0003	179.9	0.00
017	0.453	0.881	06.42	0.7681	-0.0597	0.1358	-0.7786	-0.0470	0.5900	0.0020	06.42	(0.00	-0.0043	-0.0012	-0.0009	179.9	0.00
018	0.455	0.881	05.90	0.7262	-0.0469	0.1229	-0.7351	-0.0455	0.5274	0.0020	05.90	(0.00	-0.0044	-0.0009	-0.0010	179.9	0.00
019	0.455	0.881	05.39	0.6891	-0.0383	0.1132	-0.6968	-0.0458	0.4748	0.0021	05.39	(0.00	-0.0031	-0.0009	-0.0003	179.9	0.00
020	0.453	0.880	04.36	0.6112	-0.0214	0.0944	-0.6167	-0.0458	0.3735	0.0019	04.36	(0.00	-0.0039	-0.0011	0.0002	180.0	0.00
021	0.453	0.880	03.31	0.5240	-0.0104	0.0781	-0.5278	-0.0458	0.2745	0.0019	03.31	(0.00	-0.0018	-0.0002	0.0013	180.0	0.00
022	0.455	0.881	01.20	0.3173	0.0050	0.0576	-0.3185	-0.0492	0.1005	0.0018	01.20	(0.01	-0.0005	0.0002	0.0015	180.0	0.00
023	0.455	0.881	-00.94	0.0544	0.0302	0.0454	-0.0538	-0.0446	0.0029	0.0018	-00.94	(0.01	0.0011	0.0003	0.0017	180.0	-0.00
024	0.453	0.879	-03.10	-0.2617	0.0673	0.0547	0.2641	-0.0392	0.0683	0.0014	-03.10	(0.01	0.0044	0.0008	0.0016	180.0	-0.00
027	0.457	0.861	07.46	0.7973	-0.0346	0.1509	-0.8102	-0.0439	0.6356	0.0018	07.46	(0.00	-0.0050	-0.0011	0.0033	180.0	0.00
028	0.457	0.862	06.95	0.7940	-0.0432	0.1425	-0.8085	-0.0433	0.6303	0.0021	06.95	(0.00	-0.0065	-0.0011	0.0003	180.0	0.00
029	0.457	0.860	06.43	0.7723	-0.0458	0.1306	-0.7821	-0.0415	0.5963	0.0018	06.43	(0.00	-0.0046	-0.0010	-0.0001	179.9	0.00
030	0.455	0.859	05.92	0.7358	-0.0361	0.1189	-0.7443	-0.0405	0.5414	0.0019	05.92	(0.00	-0.0047	-0.0009	-0.0004	179.9	0.00
031	0.457	0.861	05.40	0.6961	-0.0267	0.1076	-0.7032	-0.0396	0.4844	0.0020	05.40	(0.00	-0.0043	-0.0009	-0.0002	179.9	0.00
032	0.455	0.859	04.37	0.6200	-0.0086	0.0899	-0.6281	-0.0400	0.3843	0.0020	04.37	(0.00	-0.0044	-0.0008	0.0003	180.0	0.00
033	0.457	0.860	03.33	0.5351	0.0041	0.0746	-0.5386	-0.0416	0.2862	0.0019	03.33	(0.01	-0.0023	-0.0002	0.0012	180.0	0.00
034	0.458	0.859	01.22	0.3294	0.0219	0.0529	-0.3305	-0.0441	0.1083	0.0018	01.22	(0.01	-0.0003	0.0005	0.0016	180.0	0.00
035	0.455	0.860	-00.93	0.0532	0.0434	0.0426	-0.0526	-0.0419	0.0027	0.0016	-00.93	(0.01	-0.0008	0.0003	0.0016	180.0	0.00
036	0.457	0.860	-03.10	-0.2479	0.0629	0.0494	0.2501	-0.0347	0.0613	0.0013	-03.10	(0.01	0.0016	0.0004	0.0016	180.0	-0.00
039	0.450	0.839	07.42	0.7979	-0.0663	0.1460	-0.8101	-0.0401	0.6365	0.0016	07.42	(0.00	-0.0034	-0.0009	0.0035	180.0	0.00
040	0.453	0.840	06.93	0.7794	-0.0449	0.1358	-0.7899	-0.0368	0.6074	0.0017	06.93	(0.00	-0.0033	-0.0008	0.0026	180.0	0.00
041	0.453	0.843	06.43	0.7728	-0.0424	0.1286	-0.7821	-0.0363	0.5971	0.0020	06.43	(0.00	-0.0043	-0.0010	0.0011	180.0	0.00
042	0.453	0.841	05.92	0.7452	-0.0278	0.1194	-0.7533	-0.0361	0.5593	0.0018	05.92	(0.00	-0.0052	-0.0009	-0.0004	179.9	0.00
043	0.453	0.839	05.41	0.7096	-0.0164	0.1062	-0.7166	-0.0370	0.5035	0.0018	05.41	(0.00	-0.0041	-0.0007	0.0001	180.0	0.00
044	0.453	0.841	04.38	0.6325	0.0015	0.0864	-0.6374	-0.0358	0.4000	0.0019	04.38	(0.00	-0.0033	-0.0008	0.0005	180.0	0.00

TABLE 2(A)
CLEAN AIRCRAFT
ETA = 0° ETRACT = -2 1/2°

SER	REVW.	MACH.	INCJD.	LIFT.	PITCH.	DRAG	NORMAL	AXIAL.	CLSD.	BASE.	RINC.	SLIP.	CROSS.	YAW M.	ROLL N	RANG.	SIDE F
045	0.453	0.840	03.35	0.5499	0.0173	0.0711	-0.5533	-0.0371	0.3022	0.0038	03.35	00.00	-0.0023	-0.0004	0.0012	180.0	0.0022
046	0.457	0.839	01.23	0.3260	0.0371	0.0498	-0.3271	-0.0411	0.1062	0.0018	01.23	-00.01	0.0002	0.0010	0.0017	180.0	-0.0003
047	0.457	0.839	00.93	0.0459	0.0516	0.0413	-0.0453	-0.0407	0.0020	0.0013	-00.93	-00.01	-0.0003	0.0002	0.0015	180.0	0.0002
048	0.457	0.840	-03.09	-0.2369	0.0613	0.0467	0.2389	-0.0327	0.0560	0.0012	-03.09	-00.01	0.0021	0.0003	0.0017	180.0	-0.0022
051	0.463	0.800	07.43	0.8080	-0.0493	0.1407	-0.8196	-0.0334	0.6529	0.0016	07.43	00.00	-0.0042	-0.0010	0.0013	180.0	0.0041
052	0.462	0.798	06.93	0.7849	-0.0392	0.1306	-0.7950	-0.0335	0.6159	0.0015	06.93	00.00	-0.0032	-0.0006	0.0027	180.0	0.0031
053	0.463	0.801	06.43	0.7585	-0.0194	0.1180	-0.7670	-0.0306	0.5751	0.0017	06.43	00.00	-0.0024	-0.0007	0.0036	180.0	0.0023
054	0.463	0.801	05.95	0.7327	0.0167	0.1061	-0.7399	-0.0280	0.5368	0.0016	05.95	-00.01	-0.0024	-0.0001	0.0024	180.0	0.0023
055	0.463	0.801	05.44	0.7344	0.0046	0.0989	-0.7406	-0.0271	0.5394	0.0017	05.44	00.00	-0.0031	-0.0008	0.0007	180.0	0.0030
056	0.463	0.801	04.42	0.6607	0.0277	0.0784	-0.6649	-0.0256	0.4364	0.0017	04.42	00.00	-0.0047	-0.0007	0.0011	180.0	0.0046
057	0.465	0.799	03.37	0.5578	0.0444	0.0624	-0.5606	-0.0277	0.3110	0.0017	03.37	-00.01	-0.0019	-0.0001	0.0022	180.0	0.0018
058	0.463	0.800	01.22	0.2980	0.0527	0.0439	-0.2989	-0.0359	0.0886	0.0017	01.22	-00.01	-0.0013	0.0003	0.0016	180.0	0.0012
059	0.463	0.800	-00.93	0.0394	0.0577	0.0391	-0.0388	-0.0185	0.0014	0.0014	-00.93	-00.01	-0.0005	0.0002	0.0015	180.0	0.0004
060	0.465	0.799	-03.07	-0.2204	0.0652	0.0432	0.2223	-0.0303	0.0484	0.0018	-03.07	-00.01	0.0013	0.0002	0.0017	180.0	-0.0004
063	0.462	0.752	07.43	0.8011	-0.0206	0.1335	-0.8117	-0.0268	0.6417	0.0018	07.43	00.00	-0.0028	-0.0004	0.0030	180.0	0.0027
064	0.463	0.749	06.93	0.7928	-0.0165	0.1227	-0.8019	-0.0247	0.6284	0.0014	06.93	00.00	-0.0023	-0.0001	0.0033	180.0	0.0022
065	0.462	0.750	06.43	0.7671	-0.0037	0.1112	-0.7748	-0.0230	0.5883	0.0016	06.43	00.00	-0.0013	0.0001	0.0039	180.0	0.0012
066	0.462	0.751	05.93	0.7446	0.0098	0.1014	-0.7512	-0.0223	0.5542	0.0016	05.93	00.00	-0.0000	0.0004	0.0046	180.0	-0.0001
067	0.462	0.751	05.43	0.7182	0.0290	0.0893	-0.7235	-0.0192	0.5157	0.0017	05.43	-00.01	-0.0011	0.0003	0.0033	180.0	0.0010
068	0.462	0.751	04.41	0.6435	0.0518	0.0709	-0.6472	-0.0194	0.4140	0.0018	04.41	-00.01	-0.0028	-0.0002	0.0019	180.0	0.0027
069	0.463	0.749	03.34	0.5185	0.0545	0.0555	-0.5210	-0.0237	0.2687	0.0016	03.34	-00.01	-0.0005	0.0003	0.0022	180.0	0.0004
070	0.463	0.750	01.20	0.2737	0.0546	0.0429	-0.2747	-0.0356	0.0748	0.0016	01.20	-00.01	-0.0013	-0.0002	0.0016	180.0	0.0012
071	0.462	0.750	-00.93	0.0327	0.0616	0.0383	-0.0321	-0.0375	0.0010	0.0014	-00.93	-00.01	-0.0001	0.0000	0.0015	180.0	0.0000
072	0.463	0.750	-03.06	-0.2064	0.0713	0.0443	0.2084	-0.0321	0.0424	0.0012	-03.06	-00.01	0.0011	0.0005	0.0018	180.0	-0.0012
075	0.445	0.699	07.42	0.7800	0.0206	0.1276	-0.7901	-0.0241	0.6083	0.0017	07.42	-00.01	-0.0018	0.0003	0.0035	180.0	0.0017
076	0.449	0.700	06.90	0.7817	-0.0027	0.1169	-0.7902	-0.0203	0.6110	0.0018	06.90	-00.01	-0.0014	0.0006	0.0041	180.0	0.0013
077	0.449	0.701	06.40	0.7628	0.0148	0.1045	-0.7698	-0.0170	0.5818	0.0017	06.40	-00.01	-0.0014	0.0004	0.0043	180.0	0.0013
078	0.449	0.700	05.90	0.7338	0.0292	0.0933	-0.7396	-0.0156	0.5385	0.0018	05.90	-00.01	-0.0009	0.0004	0.0038	180.0	0.0008
079	0.449	0.700	05.39	0.6946	0.0395	0.0823	-0.6994	-0.0149	0.4823	0.0018	05.39	-00.01	-0.0013	0.0003	0.0032	180.0	0.0012
080	0.449	0.700	04.35	0.6015	0.0510	0.0645	-0.6047	-0.0171	0.3616	0.0016	04.35	-00.01	-0.0014	0.0003	0.0028	180.0	0.0013
081	0.449	0.701	03.29	0.4871	0.0515	0.0530	-0.4894	-0.0231	0.2371	0.0019	03.29	-00.01	-0.0008	0.0003	0.0027	180.0	0.0007
082	0.449	0.700	01.17	0.2587	0.0546	0.0411	-0.2596	-0.0343	0.0668	0.0016	01.17	-00.01	-0.0009	0.0004	0.0016	180.0	0.0008
083	0.449	0.699	-00.94	0.0285	0.0634	0.0378	-0.0280	-0.0371	0.0007	0.0012	-00.94	-00.01	0.0005	0.0002	0.0016	180.0	-0.0006
084	0.449	0.701	-03.05	-0.1987	0.0742	0.0431	0.2006	-0.0314	0.0394	0.0012	-03.05	-00.01	0.0016	0.0002	0.0017	180.0	-0.0017
087	0.444	0.502	07.29	0.7549	0.0008	0.1188	-0.7640	-0.0200	0.5697	0.0021	07.29	-00.01	-0.0020	0.0009	0.0028	180.0	0.0019
088	0.444	0.502	06.79	0.7333	0.0166	0.1025	-0.7403	-0.0132	0.5376	0.0020	06.79	-00.01	-0.0021	0.0009	0.0024	180.0	0.0020

TABLE 2(A)
 CLEAN AIRCRAFT
 ETA = 0° ETR(T) = -2 1/2°

SER	REYN.	MACH.	INCID.	LIFT.	PITCH.	DRAG	NORMAL	AXIAL.	CLSQ.	BASE.	AINC.	S.I.P.	CROSS.	YAW M.	ROLL M	RYAW.	SIDE F
089	0.444	0.501	06.28	0.6940	0.0280	0.0891	-0.6997	-0.0108	0.4815	0.0019	06.28	-00.01	-0.0025	0.0007	0.0022	180.0	0.0025
090	0.444	0.499	05.76	0.6504	0.0351	0.0781	-0.6551	-0.0105	0.4229	0.0018	05.76	-00.01	-0.0018	0.0008	0.0021	180.0	0.0017
091	0.444	0.500	05.25	0.6055	0.0394	0.0695	-0.6095	-0.0118	0.3666	0.0020	05.25	-00.01	-0.0018	0.0006	0.0024	180.0	0.0017
092	0.444	0.501	04.22	0.5136	0.0429	0.0564	-0.5165	-0.0167	0.2636	0.0018	04.22	-00.01	-0.0010	0.0007	0.0028	180.0	0.0009
093	0.444	0.501	03.18	0.4202	0.0459	0.0477	-0.4223	-0.0224	0.1765	0.0019	03.18	-00.01	-0.0010	0.0005	0.0024	180.0	0.0009
094	0.444	0.500	01.11	0.2247	0.0533	0.0384	-0.2255	-0.0324	0.0504	0.0017	01.11	-00.01	0.0000	0.0004	0.0017	180.0	-0.0001
095	0.444	0.499	-00.96	0.0223	0.0639	0.0363	-0.0218	-0.0353	0.0004	0.0015	-00.96	-00.01	0.0005	0.0001	0.0017	180.0	-0.0006
096	0.444	0.499	-03.03	-0.1799	0.0777	0.0401	0.1817	-0.0293	0.0322	0.0013	-03.03	-00.01	0.0015	0.0002	0.0020	180.0	-0.0016

TABLE 2(B)
 CLEAN AIRCRAFT
 ETR - G' ETRACT) = -1 1/2"

SER	REVW	HACH	INC.D	LIFT	PITCH	DRAW	NORMAL	AXIAL	CLSB	BASE	AINC	SLIP	CROSS	YAW M	ROLL M	RANG	SIDE F
099	0.455	0.899	07.44	0.8495	-0.0868	0.1679	-0.8642	-0.0544	0.7216	0.0020	07.44	(-0.01	0.0004	0.0017	-0.0006	179.9	-0.0004
100	0.455	0.899	06.92	0.8172	-0.0889	0.1548	-0.8300	-0.0530	0.6677	0.0021	06.92	(-0.01	0.0018	0.0017	-0.0009	179.9	-0.0019
101	0.452	0.899	06.40	0.7771	-0.0865	0.1406	-0.7880	-0.0510	0.6038	0.0021	06.40	(-0.01	0.0014	0.0014	-0.0018	179.9	-0.0018
102	0.452	0.897	05.88	0.7420	-0.0835	0.1281	-0.7513	-0.0493	0.5505	0.0021	05.88	(-0.01	0.0013	0.0012	-0.0012	179.9	-0.0012
103	0.455	0.899	05.36	0.7038	-0.0764	0.1183	-0.7119	-0.0500	0.4951	0.0021	05.36	(-0.01	0.0003	0.0016	-0.0010	179.9	-0.0003
104	0.455	0.900	04.32	0.6233	-0.0659	0.1005	-0.6293	-0.0513	0.3885	0.0020	04.32	(-0.01	0.0017	0.0017	0.0001	180.0	-0.0018
105	0.455	0.899	03.27	0.5284	-0.0543	0.0828	-0.5323	-0.0506	0.2790	0.0019	03.27	(-0.02	0.0034	0.0023	0.0007	180.0	-0.0018
106	0.455	0.899	04.16	0.3066	-0.0315	0.0597	-0.3078	-0.0517	0.0938	0.0018	01.16	(-0.02	0.0044	0.0026	0.0009	180.0	-0.0044
107	0.453	0.901	-00.98	0.0361	0.0020	0.0506	-0.0354	-0.0495	0.0012	0.0018	-00.98	(-0.02	0.0063	0.0030	0.0010	180.0	-0.0064
108	0.455	0.901	-03.12	-0.2636	0.0487	0.0606	0.2664	-0.0447	0.0693	0.0015	-03.12	(-0.02	0.0081	0.0039	0.0013	180.0	-0.0082
002	0.457	0.878	07.49	0.8097	-0.0177	0.1549	-0.8231	-0.0461	0.6555	0.0019	07.49	(-0.01	-0.0012	0.0012	0.0018	180.0	0.0011
003	0.458	0.880	06.93	0.8093	-0.0779	0.1475	-0.8213	-0.0468	0.6548	0.0020	06.93	(-0.01	0.0004	0.0016	-0.0003	179.9	-0.0003
004	0.458	0.879	06.41	0.7763	-0.0740	0.1354	-0.7867	-0.0458	0.6025	0.0020	06.41	(-0.01	-0.0003	0.0012	-0.0002	179.9	-0.0002
005	0.458	0.880	05.89	0.7374	-0.0703	0.1229	-0.7463	-0.0445	0.5437	0.0021	05.89	(-0.01	0.0013	0.0014	-0.0012	179.9	-0.0014
006	0.457	0.880	05.37	0.6998	-0.0627	0.1116	-0.7073	-0.0435	0.4896	0.0021	05.37	(-0.01	0.0014	0.0016	-0.0008	179.9	-0.0015
007	0.458	0.880	04.34	0.6221	-0.0470	0.0927	-0.6274	-0.0433	0.3859	0.0021	04.34	(-0.01	0.0009	0.0017	-0.0003	179.9	-0.0018
008	0.457	0.880	03.30	0.5353	-0.0360	0.0771	-0.5389	-0.0443	0.2863	0.0018	03.30	(-0.02	0.0028	0.0020	0.0007	180.0	-0.0021
009	0.457	0.879	04.18	0.3272	-0.0159	0.0554	-0.3284	-0.0465	0.1070	0.0018	01.18	(-0.02	0.0042	0.0025	0.0009	180.0	-0.0043
010	0.452	0.882	-00.96	0.0590	0.0090	0.0443	-0.0584	-0.0437	0.0034	0.0016	-00.96	(-0.02	0.0049	0.0030	0.0012	180.0	-0.0050
011	0.458	0.880	-03.12	-0.2579	0.0466	0.0526	0.2603	-0.0373	0.0664	0.0013	-03.12	(-0.02	0.0085	0.0035	0.0011	180.0	-0.0086
014	0.455	0.859	07.43	0.8016	-0.0687	0.1499	-0.8144	-0.0434	0.6425	0.0017	07.43	(-0.01	0.0011	0.0014	0.0047	180.0	-0.0011
015	0.455	0.858	06.95	0.7823	-0.0294	0.1384	-0.7934	-0.0410	0.6119	0.0017	06.95	(-0.01	-0.0009	0.0013	0.0018	180.0	0.0009
016	0.457	0.861	06.41	0.7824	-0.0698	0.1316	-0.7923	-0.0415	0.6121	0.0019	06.41	(-0.01	0.0004	0.0013	-0.0007	179.9	-0.0005
017	0.455	0.860	05.90	0.7469	-0.0605	0.1189	-0.7553	-0.0395	0.5579	0.0019	05.90	(-0.01	0.0005	0.0014	-0.0008	179.9	-0.0005
018	0.455	0.862	05.38	0.7064	-0.0519	0.1081	-0.7135	-0.0393	0.4989	0.0020	05.38	(-0.01	0.0012	0.0015	-0.0006	179.9	-0.0012
019	0.455	0.861	04.35	0.6315	-0.0346	0.0890	-0.6365	-0.0393	0.3987	0.0020	04.35	(-0.01	0.0008	0.0016	-0.0002	179.9	-0.0009
020	0.455	0.860	03.31	0.5470	-0.0217	0.0733	-0.5904	-0.0370	0.2990	0.0019	03.31	(-0.02	0.0037	0.0026	0.0007	180.0	-0.0038
021	0.455	0.861	04.20	0.3396	-0.0018	0.0510	-0.3407	-0.0420	0.1152	0.0018	01.20	(-0.02	0.0041	0.0028	0.0011	180.0	-0.0042
022	0.455	0.860	-00.95	0.0591	0.0235	0.0417	-0.0589	-0.0411	0.0034	0.0016	-00.95	(-0.02	0.0047	0.0027	0.0010	180.0	-0.0048
023	0.455	0.860	-03.11	-0.2426	0.0415	0.0473	0.2447	-0.0328	0.0587	0.0013	-03.11	(-0.02	0.0072	0.0032	0.0012	180.0	-0.0073
026	0.450	0.839	07.40	0.8077	-0.0849	0.1469	-0.8200	-0.0398	0.6523	0.0018	07.40	(-0.01	0.0018	0.0018	0.0037	180.0	-0.0019
027	0.450	0.839	06.90	0.7835	-0.0729	0.1363	-0.7943	-0.0394	0.6138	0.0017	06.90	(-0.01	0.0030	0.0017	0.0032	180.0	-0.0031
028	0.450	0.839	06.42	0.7711	-0.0409	0.1285	-0.7808	-0.0367	0.5946	0.0017	06.42	(-0.01	0.0004	0.0018	-0.0011	180.0	-0.0008
029	0.453	0.841	05.91	0.7571	-0.0518	0.1166	-0.7651	-0.0362	0.5731	0.0018	05.91	(-0.01	0.0007	0.0014	-0.0008	179.9	-0.0008
030	0.453	0.841	05.39	0.7196	-0.0415	0.1032	-0.7264	-0.0351	0.5178	0.0020	05.39	(-0.01	0.0017	0.0014	-0.0003	179.9	-0.0018
031	0.450	0.840	04.36	0.6456	-0.0233	0.0862	-0.6504	-0.0349	0.4166	0.0019	04.36	(-0.01	0.0010	0.0015	0.0002	180.0	-0.0011

TABLE 2(B)
 CLEAR AIRCRAFT
 ETA = 0°E(AC) = -1 1/2°

SER	REYN.	HACH.	INCID.	LIFT.	PITCH.	DRAW	NORMAL	AXIAL.	CLSO.	BASE.	RIHC.	SLIP.	CROSS.	YAW M.	ROLL M	RANG.	SIDE F
032	0.453	0.841	03.33	0.5597	-0.0094	0.0706	-0.5630	-0.0362	0.3131	0.0018	03.33	-(0.01	0.0026	0.0020	0.0008	180.0	-0.0027
033	0.450	0.838	01.21	0.3339	0.0154	0.0476	-0.3350	-0.0389	0.1114	0.0016	01.21	-(0.02	0.0046	0.0026	0.0011	180.0	-0.0047
034	0.453	0.840	-00.94	0.0519	0.0311	0.0388	-0.0534	-0.0380	0.0028	0.0015	-00.94	-(0.02	0.0050	0.0028	0.0009	180.0	-0.0081
035	0.453	0.840	-03.11	-0.2310	0.0395	0.0441	0.2329	-0.0303	0.0532	0.0013	-03.11	-(0.02	0.0065	0.0030	0.0013	180.0	-0.0078
039	0.453	0.799	07.41	0.6103	-0.0586	0.1414	-0.8219	-0.0339	0.6565	0.0018	07.41	-(0.01	0.0001	0.0011	0.0004	180.0	-0.0002
040	0.450	0.801	06.91	0.7868	-0.0486	0.1289	-0.7967	-0.0317	0.6190	0.0016	06.91	-(0.01	0.0022	0.0018	0.0021	180.0	-0.0023
041	0.450	0.800	06.41	0.7615	-0.0317	0.1184	-0.7701	-0.0310	0.5798	0.0017	06.41	-(0.01	0.0029	0.0020	0.0030	180.0	-0.0030
042	0.450	0.801	05.92	0.7427	-0.0070	0.1066	-0.7499	-0.0278	0.5516	0.0016	05.92	-(0.01	0.0028	0.0023	0.0021	180.0	-0.0029
043	0.450	0.802	05.41	0.7430	-0.0215	0.0998	-0.7492	-0.0275	0.5520	0.0018	05.41	-(0.01	0.0026	0.0016	0.0003	180.0	-0.0027
044	0.450	0.799	04.39	0.6727	0.0037	0.0789	-0.6769	-0.0253	0.4525	0.0018	04.39	-(0.01	0.0019	0.0017	0.0007	180.0	-0.0020
045	0.450	0.800	03.34	0.5690	0.0189	0.0624	-0.5718	-0.0273	0.3236	0.0018	03.34	-(0.02	0.0037	0.0025	0.0015	180.0	-0.0038
046	0.450	0.800	01.20	0.3061	0.0292	0.0433	-0.3070	-0.0353	0.0936	0.0015	01.20	-(0.02	0.0019	0.0028	0.0011	180.0	-0.0040
047	0.450	0.799	-00.94	0.0458	0.0369	0.0379	-0.0453	-0.0373	0.0020	0.0014	-00.94	-(0.02	0.0052	0.0026	0.0009	180.0	-0.0083
048	0.450	0.800	-03.09	-0.2123	0.0437	0.0422	0.2142	-0.0294	0.0449	0.0013	-03.09	-(0.02	0.0064	0.0028	0.0012	180.0	-0.0068
053	0.450	0.751	07.40	0.8146	-0.0558	0.1337	-0.8253	-0.0279	0.6634	0.0017	07.40	-(0.01	0.0008	0.0019	0.0011	180.0	-0.0009
052	0.450	0.750	06.91	0.7952	-0.0345	0.1224	-0.8042	-0.0244	0.6322	0.0015	06.91	-(0.01	0.0015	0.0018	0.0012	180.0	-0.0016
053	0.452	0.749	06.41	0.7832	-0.0262	0.1127	-0.7910	-0.0229	0.6133	0.0017	06.41	-(0.01	0.0043	0.0025	0.0034	180.0	-0.0044
054	0.452	0.749	05.90	0.7571	-0.0125	0.1012	-0.7636	-0.0211	0.5731	0.0017	05.90	-(0.01	0.0046	0.0028	0.0042	180.0	-0.0047
055	0.449	0.747	05.40	0.7286	0.0029	0.0995	-0.7339	-0.0188	0.5308	0.0017	05.40	-(0.01	0.0042	0.0028	0.0031	180.0	-0.0043
056	0.452	0.749	04.38	0.6528	0.0271	0.0702	-0.6564	-0.0183	0.4261	0.0018	04.38	-(0.01	0.0030	0.0021	0.0014	180.0	-0.0031
057	0.452	0.750	03.31	0.5283	0.0300	0.0552	-0.5308	-0.0229	0.2790	0.0016	03.31	-(0.01	0.0037	0.0025	0.0017	180.0	-0.0037
058	0.452	0.750	01.18	0.2820	0.0306	0.0413	-0.2829	-0.0340	0.0794	0.0018	01.18	-(0.02	0.0044	0.0026	0.0011	180.0	-0.0048
059	0.450	0.752	-00.95	0.0412	0.0392	0.0371	-0.0406	-0.0365	0.0016	0.0013	-00.95	-(0.02	0.0046	0.0027	0.0009	180.0	-0.0047
060	0.452	0.749	-03.07	-0.1987	0.0504	0.0405	0.2004	-0.0288	0.0394	0.0011	-03.07	-(0.01	0.0063	0.0028	0.0013	180.0	-0.0064
063	0.440	0.700	07.40	0.7899	-0.0010	0.1290	-0.8001	-0.0245	0.6239	0.0017	07.40	-(0.01	0.0022	0.0024	0.0031	180.0	-0.0023
064	0.440	0.700	06.88	0.7935	-0.0236	0.1174	-0.8020	-0.0198	0.6296	0.0016	06.88	-(0.01	0.0041	0.0028	0.0035	180.0	-0.0042
065	0.440	0.701	06.39	0.7730	-0.0074	0.1043	-0.7799	-0.0160	0.5975	0.0017	06.39	-(0.01	0.0036	0.0027	0.0034	180.0	-0.0037
066	0.439	0.702	05.88	0.7487	0.0060	0.0933	-0.7814	-0.0147	0.5960	0.0017	05.88	-(0.01	0.0039	0.0027	0.0032	180.0	-0.0040
067	0.440	0.700	05.37	0.7049	0.0162	0.0819	-0.7096	-0.0137	0.4968	0.0017	05.37	-(0.01	0.0036	0.0025	0.0025	180.0	-0.0037
068	0.440	0.701	04.33	0.6110	0.0271	0.0651	-0.6142	-0.0171	0.3732	0.0017	04.33	-(0.01	0.0030	0.0026	0.0023	180.0	-0.0031
069	0.437	0.699	03.27	0.4959	0.0277	0.0528	-0.4982	-0.0227	0.2497	0.0017	03.27	-(0.02	0.0043	0.0030	0.0021	180.0	-0.0044
070	0.437	0.699	01.16	0.2687	0.0312	0.0408	-0.2698	-0.0337	0.0780	0.0013	01.16	-(0.01	0.0047	0.0027	0.0012	180.0	-0.0048
071	0.440	0.699	-00.95	0.0375	0.0409	0.0361	-0.0370	-0.0395	0.0013	0.0012	-00.95	-(0.01	0.0052	0.0024	0.0009	180.0	-0.0083
072	0.440	0.700	-03.06	-0.1904	0.0333	0.0403	0.1922	-0.0292	0.0361	0.0012	-03.06	-(0.01	0.0060	0.0026	0.0013	180.0	-0.0061
075	0.440	0.502	07.28	0.7690	-0.0205	0.1198	-0.7780	-0.0195	0.5912	0.0019	07.28	-(0.01	0.0026	0.0029	0.0023	180.0	-0.0087
076	0.440	0.499	06.77	0.7419	-0.0043	0.1024	-0.7489	-0.0124	0.5503	0.0018	06.77	-(0.01	0.0029	0.0028	0.0020	180.0	-0.0038

TABLE 2(B)
 CLEAN AIRCRAFT
 ETR = 0° ETR(T) = -1 1/2°

SER	REYN.	MACH.	INCID.	LIFT.	PITCH.	DRAW	NORMAL	AXIAL.	CLSQ.	BASE.	RINC.	SLIP.	CROSS.	YAW M.	ROLL M	RANG.	SIDE F
077	0.440	0.500	06.27	0.7065	0.0070	0.0896	-0.7122	-0.0101	0.4991	0.0018	06.27	-(0.01	0.0023	0.0027	0.0017	180.0	-0.0024
078	0.440	0.500	05.76	0.6646	0.0138	0.0787	-0.6692	-0.0099	0.4415	0.0018	05.76	-(0.01	0.0029	0.0027	0.0017	180.0	-0.0030
079	0.440	0.500	05.24	0.6185	0.0176	0.0696	-0.6224	-0.0108	0.3825	0.0020	05.24	-(0.01	0.0030	0.0027	0.0020	180.0	-0.0031
080	0.440	0.501	04.21	0.5266	0.0212	0.0563	-0.5294	-0.0157	0.2771	0.0018	04.21	-(0.01	0.0040	0.0027	0.0023	180.0	-0.0041
081	0.440	0.500	03.17	0.4307	0.0239	0.0477	-0.4328	-0.0220	0.1854	0.0018	03.17	-(0.01	0.0038	0.0026	0.0019	180.0	-0.0039
082	0.440	0.499	01.10	0.2345	0.0313	0.0385	-0.2353	-0.0323	0.0549	0.0017	01.10	-(0.01	0.0042	0.0022	0.0013	180.0	-0.0043
083	0.440	0.500	-00.97	0.0313	0.0418	0.0351	-0.0308	-0.0343	0.0009	0.0014	-00.97	-(0.01	0.0054	0.0025	0.0013	180.0	-0.0038
084	0.440	0.499	-03.04	-0.1717	0.0553	0.0387	0.1734	-0.0282	0.0293	0.0014	-03.04	-(0.01	0.0065	0.0025	0.0015	180.0	-0.0066

TABLE 2(C)
CLEAN AIRCRAFT
ETA = 0° ETRACT = 1'2"

SER	REYN.	MACH.	INCID.	LIFT.	PITCH.	DRAW	NORMAL	AXIAL.	CLSO.	BASE.	AINC.	SLIP.	CROSS.	YAW M.	ROLL M	RANG.	SIDE P
090	0.435	0.901	07.43	0.8750	-0.1207	0.1727	-0.8901	-0.0558	0.7654	0.0023	07.43	(0.00	-0.0018	-0.0010	-0.0009	179.9	0.0017
091	0.435	0.901	06.91	0.8389	-0.1190	0.1571	-0.8518	-0.0529	0.7037	0.0022	06.91	(0.00	-0.0016	-0.0013	-0.0005	179.9	0.0018
092	0.435	0.901	06.38	0.7976	-0.1126	0.1429	-0.8087	-0.0509	0.6361	0.0024	06.38	(0.00	-0.0013	-0.0013	-0.0009	179.9	0.0018
093	0.435	0.900	05.87	0.7566	-0.1061	0.1300	-0.7661	-0.0496	0.5724	0.0024	05.87	(0.00	-0.0016	-0.0013	-0.0006	179.9	0.0018
096	0.439	0.902	05.35	0.7210	-0.1008	0.1207	-0.7292	-0.0456	0.5197	0.0024	05.35	(0.00	0.0002	-0.0014	-0.0008	179.9	-0.0003
097	0.435	0.900	04.31	0.6357	-0.0847	0.0999	-0.6415	-0.0497	0.4040	0.0022	04.31	(0.00	-0.0001	-0.0008	0.0004	180.0	0.0009
098	0.435	0.900	03.26	0.5447	-0.0781	0.0849	-0.5487	-0.0514	0.2965	0.0024	03.26	(0.00	0.0008	-0.0004	0.0010	180.0	-0.0009
099	0.439	0.901	01.14	0.3191	-0.0525	0.0598	-0.3163	-0.0517	0.0992	0.0019	01.14	(0.00	0.0007	-0.0003	0.0014	180.0	-0.0009
100	0.478	0.900	-00.99	0.0434	-0.0127	0.0494	-0.0426	-0.0483	0.0018	0.0019	-00.99	(0.00	0.0030	0.0003	0.0018	180.0	-0.0031
101	0.439	0.900	-03.14	-0.2628	0.0359	0.0574	0.2654	-0.0415	0.0689	0.0015	-03.14	(-0.01	0.0036	0.0004	0.0022	180.0	-0.0037
102	0.432	0.880	07.43	0.8389	-0.0913	0.1578	-0.8523	-0.0459	0.7036	0.0021	07.43	(0.00	-0.0016	-0.0010	0.0010	180.0	0.0019
103	0.432	0.880	06.91	0.8241	-0.1028	0.1493	-0.8362	-0.0471	0.6791	0.0020	06.91	(0.00	-0.0009	-0.0013	-0.0013	179.9	0.0008
104	0.429	0.878	06.39	0.7904	-0.0975	0.1365	-0.8008	-0.0456	0.6246	0.0021	06.39	(0.00	-0.0019	-0.0015	-0.0016	179.9	0.0018
105	0.429	0.879	05.87	0.7535	-0.0893	0.1233	-0.7623	-0.0434	0.5677	0.0021	05.87	(0.00	-0.0013	-0.0011	-0.0007	179.9	0.0012
106	0.432	0.881	05.35	0.7126	-0.0839	0.1133	-0.7202	-0.0441	0.5077	0.0022	05.35	(0.00	-0.0011	-0.0012	-0.0005	179.9	0.0010
107	0.432	0.879	04.32	0.6342	-0.0649	0.0937	-0.6396	-0.0436	0.4021	0.0020	04.32	(0.00	-0.0013	-0.0010	0.0001	179.9	0.0012
108	0.432	0.881	03.28	0.5479	-0.0561	0.0771	-0.5919	-0.0437	0.2999	0.0020	03.28	(0.00	0.0002	-0.0004	0.0010	180.0	-0.0003
109	0.432	0.879	01.17	0.3393	-0.0351	0.0550	-0.3404	-0.0462	0.1130	0.0018	01.17	(0.00	0.0008	0.0000	0.0013	180.0	-0.0008
110	0.432	0.879	-00.97	0.0671	-0.0040	0.0436	-0.0664	-0.0431	0.0044	0.0017	-00.97	(0.00	0.0022	0.0001	0.0018	180.0	-0.0023
111	0.432	0.880	-03.13	-0.2571	0.0340	0.0518	0.2595	-0.0362	0.0659	0.0016	-03.13	(-0.01	0.0042	0.0007	0.0018	180.0	-0.0043
114	0.442	0.899	07.40	0.8177	-0.1027	0.1518	-0.8306	-0.0432	0.6686	0.0020	07.40	(0.00	-0.0013	-0.0013	0.0035	180.0	0.0012
115	0.444	0.861	06.91	0.8118	-0.0967	0.1451	-0.8230	-0.0406	0.6588	0.0019	06.91	(0.00	-0.0019	-0.0013	0.0004	180.0	0.0018
116	0.440	0.862	06.40	0.7933	-0.0875	0.1328	-0.8033	-0.0416	0.6291	0.0019	06.40	(0.00	-0.0021	-0.0014	-0.0012	179.9	0.0028
117	0.442	0.859	05.89	0.7594	-0.0785	0.1193	-0.7678	-0.0389	0.5767	0.0019	05.89	(0.00	-0.0014	-0.0014	-0.0006	179.9	0.0013
118	0.440	0.860	05.37	0.7198	-0.0704	0.1066	-0.7267	-0.0367	0.5181	0.0020	05.37	(0.00	-0.0011	-0.0013	-0.0002	179.9	0.0018
119	0.440	0.859	04.34	0.6450	-0.0538	0.0886	-0.6500	-0.0374	0.4199	0.0021	04.34	(0.00	0.0002	-0.0009	0.0003	180.0	-0.0003
120	0.442	0.859	03.30	0.5604	-0.0397	0.0737	-0.5638	-0.0394	0.3139	0.0019	03.30	(0.00	0.0008	-0.0008	0.0013	180.0	-0.0009
121	0.440	0.861	01.19	0.3494	-0.0191	0.0510	-0.3505	-0.0421	0.1220	0.0017	01.19	(0.00	0.0015	0.0002	0.0017	180.0	-0.0016
122	0.440	0.860	-00.96	0.0645	0.0078	0.0395	-0.0639	-0.0391	0.0040	0.0015	-00.96	(0.00	0.0008	0.0001	0.0018	180.0	-0.0009
123	0.442	0.859	-03.13	-0.2408	0.0283	0.0499	0.2428	-0.0330	0.0578	0.0014	-03.13	(-0.01	0.0028	0.0003	0.0021	180.0	-0.0029
124	0.437	0.840	07.39	0.8160	-0.1032	0.1468	-0.8282	-0.0387	0.6658	0.0019	07.39	(0.00	-0.0011	-0.0011	0.0022	180.0	0.0018
125	0.437	0.840	06.90	0.7892	-0.0786	0.1353	-0.7999	-0.0376	0.6288	0.0018	06.90	(0.00	-0.0008	-0.0010	0.0024	180.0	0.0007
126	0.437	0.841	06.40	0.7796	-0.0721	0.1239	-0.7887	-0.0344	0.6077	0.0018	06.40	(0.00	-0.0004	-0.0012	0.0005	180.0	0.0003
127	0.437	0.840	05.89	0.7693	-0.0699	0.1179	-0.7774	-0.0363	0.5918	0.0019	05.89	(0.00	-0.0022	-0.0014	-0.0010	179.9	0.0021
128	0.437	0.840	05.38	0.7305	-0.0591	0.1036	-0.7371	-0.0328	0.5336	0.0019	05.38	(0.00	-0.0013	-0.0010	0.0000	179.9	0.0018
129	0.434	0.841	04.35	0.6567	-0.0424	0.0897	-0.6618	-0.0336	0.4312	0.0020	04.35	(0.00	-0.0007	-0.0011	0.0005	180.0	0.0006
130	0.434	0.839	03.31	0.5736	-0.0270	0.0700	-0.5768	-0.0349	0.3288	0.0018	03.31	(0.00	-0.0003	-0.0005	0.0013	180.0	0.0002
131	0.434	0.841	01.20	0.3496	-0.0047	0.0469	-0.3466	-0.0380	0.1193	0.0017	01.20	(-0.01	0.0019	0.0003	0.0017	180.0	-0.0016
132	0.437	0.840	-00.96	0.0583	0.0146	0.0378	-0.0577	-0.0373	0.0033	0.0015	-00.96	(-0.01	0.0010	0.0002	0.0016	180.0	-0.0011

TABLE 2(C)
CLEAN AIRCRAFT
ETA = 0° ETRACT = -1/2°

SER	REVN.	MACH.	INCID.	LIFT.	PITCH.	DRAW	NORMAL	AXIAL.	CLSQ.	BASE.	RIHC.	SLIP.	CROSS.	YAW	M.	ROLL	M	RANG.
133	0.437	0.840	-0.312	-0.2322	0.0264	0.0439	0.2341	-0.0300	0.0537	0.0013	-03.12	-00.01	0.0025	0.0003	0.0019	0.0019	180.0	0.0
136	0.455	0.802	07.42	0.8105	-0.0717	0.1412	0.8220	-0.0333	0.6568	0.0020	07.42	00.00	0.0000	-0.0007	0.0026	180.0	0.0	
137	0.455	0.800	06.51	0.8049	-0.0787	0.1306	0.8149	-0.0310	0.6477	0.0018	06.51	00.00	0.0000	-0.0007	0.0021	180.0	0.0	
138	0.455	0.801	06.41	0.7867	-0.0620	0.1200	0.7953	-0.0295	0.6187	0.0018	06.41	00.00	-0.0005	-0.0007	0.0023	180.0	0.0	
139	0.455	0.800	05.93	0.7557	-0.0243	0.1064	0.7628	-0.0258	0.5711	0.0019	05.93	00.00	0.0002	-0.0008	0.0020	180.0	0.0	
140	0.455	0.803	05.42	0.7538	-0.0390	0.1003	0.7600	-0.0266	0.5681	0.0020	05.42	00.00	-0.0019	-0.0013	0.0001	180.0	0.0	
141	0.455	0.801	04.39	0.6866	-0.0171	0.0801	0.6908	-0.0253	0.4713	0.0020	04.39	00.00	0.0002	-0.0004	0.0016	180.0	0.0	
142	0.455	0.800	03.35	0.5819	0.0008	0.0613	0.5846	-0.0255	0.3385	0.0017	03.35	00.00	0.0004	-0.0003	0.0023	180.0	0.0	
143	0.455	0.799	01.20	0.3163	0.0109	0.0424	0.3172	-0.0344	0.1000	0.0014	01.20	00.00	0.0016	0.0000	0.0018	180.0	0.0	
144	0.455	0.799	-00.96	0.0521	0.0197	0.0381	0.0516	-0.0377	0.0027	0.0013	-00.96	-00.01	0.0009	0.0001	0.0018	180.0	0.0	
145	0.455	0.799	-03.11	-0.2125	0.0297	0.0411	0.2143	-0.0283	0.0450	0.0013	-03.11	-00.01	0.0021	0.0003	0.0022	180.0	0.0	
146	0.437	0.750	07.39	0.8146	-0.0629	0.1350	0.8253	-0.0272	0.6635	0.0018	07.39	00.00	0.0016	-0.0004	0.0044	180.0	0.0	
147	0.437	0.751	06.89	0.8026	-0.0591	0.1229	0.8117	-0.0239	0.6441	0.0017	06.89	00.00	0.0025	-0.0006	0.0044	180.0	0.0	
148	0.434	0.750	06.39	0.7853	-0.0436	0.1120	0.7930	-0.0222	0.6166	0.0017	06.39	00.00	0.0029	-0.0002	0.0043	180.0	0.0	
149	0.437	0.751	05.89	0.7653	-0.0311	0.1021	0.7718	-0.0212	0.5856	0.0017	05.89	00.00	0.0024	-0.0002	0.0041	180.0	0.0	
150	0.437	0.751	05.40	0.7440	-0.0121	0.0884	0.7491	-0.0163	0.5535	0.0017	05.40	00.00	-0.0006	-0.0007	0.0025	180.0	0.0	
151	0.434	0.749	04.37	0.6647	0.0095	0.0688	0.6681	-0.0162	0.4416	0.0017	04.37	00.00	0.0001	-0.0004	0.0022	180.0	0.0	
152	0.434	0.749	03.30	0.5400	0.0117	0.0544	0.5424	-0.0216	0.2915	0.0016	03.30	00.00	0.0008	-0.0002	0.0024	180.0	0.0	
153	0.434	0.750	01.17	0.2917	0.0130	0.0411	0.2926	-0.0338	0.0850	0.0014	01.17	00.00	0.0006	-0.0001	0.0017	180.0	0.0	
154	0.437	0.751	-00.96	0.0474	0.0219	0.0363	0.0469	-0.0357	0.0021	0.0014	-00.96	00.00	0.0015	0.0001	0.0016	180.0	0.0	
155	0.437	0.751	-03.09	-0.1995	0.0345	0.0397	0.2012	-0.0277	0.0397	0.0012	-03.09	00.00	0.0028	0.0002	0.0021	180.0	0.0	
156	0.414	0.699	07.36	0.8155	-0.0569	0.1314	0.8257	-0.0241	0.6649	0.0017	07.36	00.00	0.0012	-0.0002	0.0035	180.0	0.0	
157	0.414	0.701	06.86	0.7989	-0.0422	0.1179	0.8074	-0.0198	0.6382	0.0018	06.86	00.00	0.0016	-0.0000	0.0044	180.0	0.0	
158	0.414	0.701	06.36	0.7788	-0.0273	0.1062	0.7858	-0.0175	0.6064	0.0017	06.36	00.00	0.0022	-0.0001	0.0045	180.0	0.0	
159	0.417	0.700	05.86	0.7531	-0.0127	0.0940	0.7588	-0.0148	0.5671	0.0017	05.86	00.00	0.0015	-0.0001	0.0038	180.0	0.0	
160	0.414	0.700	05.35	0.7168	-0.0014	0.0826	0.7215	-0.0137	0.5137	0.0016	05.35	00.00	0.0012	-0.0001	0.0031	180.0	0.0	
161	0.414	0.703	04.31	0.6188	0.0095	0.0645	0.6220	-0.0161	0.3829	0.0017	04.31	00.00	0.0002	0.0000	0.0029	180.0	0.0	
162	0.416	0.703	03.26	0.5069	0.0103	0.0520	0.5091	-0.0214	0.2568	0.0017	03.26	00.00	0.0013	0.0002	0.0027	180.0	0.0	
163	0.414	0.700	01.14	0.2753	0.0137	0.0403	0.2762	-0.0334	0.0757	0.0014	01.14	-00.01	0.0010	0.0003	0.0017	180.0	0.0	
164	0.414	0.701	-00.97	0.0431	0.0233	0.0353	0.0426	-0.0347	0.0018	0.0013	-00.97	00.00	0.0019	0.0000	0.0017	180.0	0.0	
165	0.414	0.700	-03.07	-0.1891	0.0368	0.0401	0.1909	-0.0287	0.0396	0.0013	-03.07	00.00	0.0021	0.0001	0.0020	180.0	0.0	
168	0.431	0.499	07.28	0.7837	-0.0317	0.1159	0.7921	-0.0138	0.6140	0.0019	07.28	00.00	0.0000	0.0001	0.0026	180.0	0.0	
169	0.431	0.501	06.78	0.7528	-0.0181	0.1021	0.7597	-0.0107	0.5666	0.0018	06.78	00.00	-0.0002	0.0002	0.0024	180.0	0.0	
170	0.431	0.502	06.27	0.7160	-0.0088	0.0893	0.7215	-0.0088	0.5125	0.0017	06.27	00.00	-0.0001	0.0002	0.0024	180.0	0.0	
171	0.434	0.500	05.75	0.6724	-0.0032	0.0782	0.6770	-0.0086	0.4520	0.0018	05.75	-00.01	-0.0001	0.0002	0.0024	180.0	0.0	
172	0.431	0.501	05.24	0.6237	0.0006	0.0694	0.6275	-0.0103	0.3889	0.0019	05.24	-00.01	0.0000	0.0003	0.0026	180.0	0.0	
173	0.431	0.501	04.20	0.5357	0.0043	0.0564	0.5385	-0.0154	0.2968	0.0017	04.20	-00.01	0.0008	0.0003	0.0030	180.0	0.0	
174	0.431	0.500	03.17	0.4428	0.0070	0.0471	0.4448	-0.0209	0.1959	0.0017	03.17	-00.01	0.0008	0.0003	0.0026	180.0	0.0	

TABLE 2(C)
 CLEAN AIRCRAFT
 $\epsilon = 0^\circ$ $\epsilon_{\text{TRACT}} = -1.72^\circ$

SER	REYN.	MACH.	INCID.	LIFT.	PITCH.	DRAG	NORMAL	AXIAL.	CLSO.	BASE.	AINC.	SLIP.	CROSS.	YAW M.	ROLL M	RANG.	SIDE P
175	0.431	0.500	01.10	0.2429	0.0146	0.0371	-0.2437	-0.0309	0.0589	0.0016	01.10	00.00	0.0015	0.0001	0.0019	180.0	-0.0016
176	0.431	0.499	-00.98	0.0363	0.0256	0.0340	-0.0358	-0.0332	0.0012	0.0014	-00.98	00.00	0.0020	0.0001	0.0021	180.0	-0.0024
177	0.431	0.501	-03.05	-0.1664	0.0392	0.0372	0.1681	-0.0271	0.0275	0.0013	-03.05	00.00	0.0027	0.0001	0.0022	180.0	-0.0029

TABLE 2(D)
 CLEAN AIRCRAFT
 ETA = 0° EYACT = +1/2°

SER	REYN.	KACH.	INCJD.	LIFT.	PITCH.	DRAG	NORMAL	AXIAL.	CLSQ.	BASE.	ALINC.	SLIP.	CROSS.	YAW M.	ROLL M	RANG.	SIDE F
002	0.458	0.898	07.43	0.8491	-0.0919	0.1676	-0.8637	-0.0543	0.7208	0.0020	07.43	(0.00	-0.0036	-0.0006	0.0001	180.0	0.0038
003	0.458	0.905	06.92	0.8188	-0.0970	0.1562	-0.8317	-0.0541	0.6703	0.0024	06.92	(0.00	-0.0054	-0.0015	-0.0006	179.9	0.0053
004	0.457	0.899	06.38	0.7810	-0.1034	0.1406	-0.7919	-0.0508	0.6099	0.0021	06.38	(0.00	-0.0031	-0.0009	-0.0012	179.9	0.0030
005	0.457	0.902	05.86	0.7513	-0.1074	0.1298	-0.7607	-0.0501	0.5643	0.0022	05.86	(0.00	-0.0040	-0.0012	-0.0007	179.9	0.0039
006	0.457	0.900	05.34	0.7154	-0.1076	0.1196	-0.7236	-0.0503	0.5118	0.0022	05.34	(0.00	-0.0051	-0.0013	-0.0007	179.9	0.0050
007	0.457	0.901	04.29	0.6379	-0.1039	0.1011	-0.6438	-0.0508	0.4068	0.0023	04.29	(0.00	-0.0036	-0.0010	0.0007	180.0	0.0035
008	0.457	0.900	03.24	0.5429	-0.0924	0.0832	-0.5468	-0.0503	0.2945	0.0021	03.24	(0.00	-0.0029	-0.0007	0.0011	180.0	0.0028
009	0.457	0.901	01.12	0.3169	-0.0717	0.0601	-0.3181	-0.0520	0.1003	0.0020	01.12	(0.00	-0.0020	-0.0005	0.0014	180.0	0.0019
010	0.457	0.901	-01.01	0.0495	-0.0369	0.0487	-0.0487	-0.0474	0.0024	0.0023	-01.01	(0.00	0.0000	0.0000	0.0016	180.0	-0.0010
011	0.457	0.900	-03.15	-0.2481	0.0106	0.0584	-0.2508	-0.0428	0.0614	0.0019	-03.15	(0.00	0.0022	0.0001	0.0017	180.0	-0.0023
014	0.455	0.881	07.44	0.8364	-0.0812	0.1599	-0.8502	-0.0483	0.6994	0.0019	07.44	(0.00	-0.0064	-0.0015	0.0004	180.0	0.0063
015	0.457	0.879	06.91	0.8159	-0.0989	0.1476	-0.8278	-0.0463	0.6655	0.0021	06.91	(0.00	-0.0049	-0.0012	0.0000	180.0	0.0048
016	0.455	0.881	06.39	0.7838	-0.1002	0.1355	-0.7941	-0.0452	0.6142	0.0023	06.39	(0.00	-0.0042	-0.0010	-0.0007	179.9	0.0041
017	0.457	0.880	05.86	0.7497	-0.1007	0.1240	-0.7586	-0.0444	0.5620	0.0023	05.86	(0.00	-0.0039	-0.0012	-0.0008	179.9	0.0038
018	0.457	0.879	05.34	0.7129	-0.0966	0.1118	-0.7203	-0.0427	0.5082	0.0021	05.34	(0.00	-0.0039	-0.0011	-0.0002	179.9	0.0036
019	0.457	0.879	04.31	0.6375	-0.0835	0.0935	-0.6428	-0.0432	0.4063	0.0021	04.31	(0.00	-0.0032	-0.0012	0.0002	180.0	0.0031
020	0.458	0.880	03.27	0.5490	-0.0737	0.0783	-0.5527	-0.0449	0.3012	0.0019	03.27	(0.00	-0.0020	-0.0008	0.0012	180.0	0.0019
021	0.458	0.881	01.15	0.3408	-0.0549	0.0551	-0.3420	-0.0463	0.1160	0.0019	01.15	(0.01	-0.0009	0.0003	0.0013	180.0	0.0008
022	0.458	0.881	-00.99	0.0735	-0.0288	0.0436	-0.0728	-0.0430	0.0053	0.0019	-00.99	(0.01	0.0000	0.0001	0.0016	180.0	-0.0001
023	0.458	0.881	-03.15	-0.2448	0.0097	0.0507	-0.2471	-0.0356	0.0398	0.0017	-03.15	(0.01	0.0040	0.0006	0.0014	180.0	-0.0041
026	0.457	0.861	07.44	0.8099	-0.0614	0.1519	-0.8229	-0.0439	0.6559	0.0018	07.44	(0.00	-0.0035	-0.0008	0.0044	180.0	0.0036
027	0.457	0.860	06.95	0.7940	-0.0387	0.1379	-0.8050	-0.0389	0.6203	0.0018	06.95	(0.00	-0.0049	-0.0009	0.0816	180.0	0.0048
028	0.457	0.862	06.39	0.7917	-0.0977	0.1321	-0.8016	-0.0410	0.6267	0.0021	06.39	(0.00	-0.0054	-0.0012	-0.0004	179.9	0.0051
029	0.457	0.860	05.88	0.7596	-0.0925	0.1194	-0.7679	-0.0391	0.5769	0.0019	05.88	(0.00	-0.0040	-0.0011	-0.0004	179.9	0.0038
030	0.457	0.860	05.36	0.7203	-0.0860	0.1082	-0.7273	-0.0385	0.5187	0.0020	05.36	(0.00	-0.0035	-0.0011	-0.0001	179.9	0.0036
031	0.457	0.860	04.33	0.6452	-0.0707	0.0902	-0.6503	-0.0394	0.4161	0.0019	04.33	(0.00	-0.0035	-0.0009	0.0003	180.0	0.0036
032	0.455	0.857	03.29	0.5631	-0.0554	0.0733	-0.5665	-0.0390	0.3169	0.0019	03.29	(0.01	-0.0025	-0.0003	0.0012	180.0	0.0028
033	0.457	0.861	01.18	0.3533	-0.0392	0.0515	-0.3544	-0.0424	0.1248	0.0018	01.18	(0.01	-0.0009	0.0003	0.0016	180.0	0.0008
034	0.457	0.861	-00.97	0.0748	-0.0143	0.0383	-0.0742	-0.0377	0.0055	0.0019	-00.97	(0.01	0.0000	0.0001	0.0014	180.0	-0.0008
035	0.458	0.857	-03.14	-0.2287	0.0090	0.0497	-0.2307	-0.0316	0.0322	0.0016	-03.14	(0.01	0.0024	0.0004	0.0018	180.0	-0.0028
038	0.465	0.840	07.40	0.8187	-0.1042	0.1490	-0.8312	-0.0405	0.6701	0.0018	07.40	(0.00	-0.0025	-0.0004	0.0044	180.0	0.0028
039	0.465	0.839	06.90	0.7917	-0.0817	0.1368	-0.8025	-0.0387	0.6266	0.0019	06.90	(0.00	-0.0026	-0.0008	0.0042	180.0	0.0036
040	0.467	0.841	06.42	0.7807	-0.0574	0.1263	-0.7900	-0.0364	0.6093	0.0018	06.42	(0.00	-0.0033	-0.0007	0.0005	180.0	0.0036
041	0.463	0.841	05.89	0.7687	-0.0835	0.1162	-0.7767	-0.0349	0.5908	0.0018	05.89	(0.00	-0.0045	-0.0011	-0.0001	179.9	0.0048
042	0.465	0.840	05.37	0.7348	-0.0754	0.1058	-0.7415	-0.0344	0.5398	0.0021	05.37	(0.00	-0.0039	-0.0012	0.0002	180.0	0.0036
043	0.465	0.839	04.34	0.6598	-0.0572	0.0898	-0.6645	-0.0336	0.4352	0.0020	04.34	(0.00	-0.0034	-0.0008	0.0009	180.0	0.0036

TABLE 2(D)
CLEAN AIRCRAFT
ETA = 0° ETRACT = +1/2°

SER	REYN.	MACH.	INCID.	LIFT.	PITCH.	DRAG	NORMAL	AXIAL.	CLSQ.	BASE.	AINC.	SLIP.	CROSS.	YAW M.	ROLL M	RANG.	SIDE F
044	0.465	0.839	03.31	0.5760	-0.0425	0.0704	-0.5792	-0.0354	0.3316	0.0017	03.31	00.00	-0.0022	-0.0008	0.0015	180.0	0.0021
045	0.463	0.841	01.19	0.3489	-0.0235	0.0494	-0.3500	-0.0403	0.1216	0.0019	01.19	-00.01	-0.0006	0.0001	0.0019	180.0	0.0005
046	0.465	0.840	-00.97	0.0681	-0.0060	0.0384	-0.0675	-0.0378	0.0045	0.0017	-00.97	00.00	0.0006	0.0000	0.0015	180.0	-0.0007
047	0.463	0.841	-03.14	-0.2186	0.0037	0.0447	0.2206	-0.0312	0.0476	0.0015	-03.14	-00.01	0.0019	0.0002	0.0020	180.0	-0.0020
050	0.455	0.799	07.39	0.8279	-0.0940	0.1428	-0.8395	-0.0333	0.6853	0.0018	07.39	00.00	-0.0038	-0.0012	0.0015	180.0	0.0037
051	0.455	0.799	06.89	0.8005	-0.0841	0.1298	-0.8104	-0.0311	0.6408	0.0018	06.89	00.00	-0.0035	-0.0009	0.0029	180.0	0.0034
052	0.458	0.801	06.38	0.7882	-0.0825	0.1197	-0.7967	-0.0296	0.6211	0.0017	06.38	00.00	-0.0022	-0.0005	0.0039	180.0	0.0021
053	0.458	0.800	05.88	0.7776	-0.0789	0.1086	-0.7847	-0.0267	0.6045	0.0017	05.88	-00.01	-0.0028	-0.0001	0.0028	180.0	0.0027
054	0.458	0.802	05.39	0.7563	-0.0537	0.1000	-0.7625	-0.0267	0.5720	0.0018	05.39	00.00	-0.0040	-0.0009	0.0007	180.0	0.0039
055	0.458	0.803	04.37	0.6850	-0.0326	0.0791	-0.6891	-0.0247	0.4690	0.0020	04.37	00.00	-0.0043	-0.0007	0.0011	180.0	0.0042
056	0.458	0.801	03.32	0.5815	-0.0164	0.0617	-0.5842	-0.0260	0.3381	0.0019	03.32	-00.01	-0.0026	-0.0003	0.0021	180.0	0.0025
057	0.458	0.801	01.18	0.3221	-0.0070	0.0427	-0.3230	-0.0344	0.1036	0.0016	01.18	-00.01	-0.0017	0.0000	0.0016	180.0	0.0016
058	0.458	0.801	-00.97	0.0611	-0.0003	0.0366	-0.0606	-0.0361	0.0036	0.0016	-00.97	00.00	0.0002	-0.0001	0.0014	180.0	-0.0003
059	0.455	0.799	-03.11	-0.1980	0.0080	0.0404	0.1998	-0.0282	0.0390	0.0015	-03.11	-00.01	0.0013	0.0002	0.0016	180.0	-0.0014
062	0.457	0.750	07.39	0.8272	-0.0792	0.1356	-0.8379	-0.0265	0.6842	0.0019	07.39	00.00	-0.0036	-0.0005	0.0019	180.0	0.0035
063	0.457	0.750	06.89	0.8013	-0.0554	0.1228	-0.8103	-0.0240	0.6419	0.0017	06.89	00.00	-0.0031	-0.0004	0.0028	180.0	0.0030
064	0.457	0.750	06.39	0.7932	-0.0587	0.1127	-0.8009	-0.0221	0.6291	0.0016	06.39	00.00	-0.0018	-0.0002	0.0039	180.0	0.0017
065	0.457	0.750	05.89	0.7720	-0.0466	0.1012	-0.7784	-0.0198	0.5959	0.0017	05.89	00.00	-0.0004	0.0001	0.0049	180.0	0.0003
066	0.457	0.752	05.41	0.7300	-0.0088	0.0892	-0.7353	-0.0180	0.5329	0.0019	05.41	00.00	-0.0004	0.0001	0.0035	180.0	0.0003
067	0.457	0.751	04.36	0.6712	-0.0074	0.0713	-0.6747	-0.0182	0.4503	0.0018	04.36	00.00	-0.0028	-0.0004	0.0019	180.0	0.0027
067	0.457	0.751	04.36	0.6712	-0.0074	0.0713	-0.6747	-0.0182	0.4503	0.0018	04.36	00.00	-0.0028	-0.0004	0.0019	180.0	0.0027
069	0.457	0.750	03.29	0.5444	-0.0048	0.0556	-0.5468	-0.0223	0.2963	0.0019	03.29	-00.01	-0.0016	0.0002	0.0021	180.0	0.0015
070	0.457	0.749	01.16	0.2979	-0.0040	0.0415	-0.2988	-0.0339	0.0886	0.0017	01.16	-00.01	-0.0014	-0.0001	0.0016	180.0	0.0013
071	0.457	0.749	-00.97	0.0556	0.0038	0.0356	-0.0551	-0.0350	0.0030	0.0016	-00.97	00.00	0.0004	0.0000	0.0015	180.0	-0.0005
072	0.457	0.749	-03.10	-0.1837	0.0143	0.0399	0.1854	-0.0286	0.0336	0.0014	-03.10	-00.01	0.0013	0.0002	0.0017	180.0	-0.0014
075	0.442	0.702	07.38	0.8038	-0.0351	0.1295	-0.8138	-0.0235	0.6459	0.0017	07.38	-00.01	-0.0026	0.0001	0.0038	180.0	0.0025
076	0.442	0.701	06.86	0.8082	-0.0367	0.1171	-0.8165	-0.0179	0.6330	0.0017	06.86	-00.01	-0.0016	0.0003	0.0038	180.0	0.0015
077	0.442	0.700	06.37	0.7894	-0.0402	0.1052	-0.7963	-0.0153	0.6231	0.0017	06.37	-00.01	-0.0015	0.0003	0.0040	180.0	0.0014
078	0.442	0.700	05.86	0.7598	-0.0274	0.0931	-0.7655	-0.0133	0.5773	0.0017	05.86	-00.01	-0.0017	0.0003	0.0038	180.0	0.0016
079	0.442	0.701	05.35	0.7210	-0.0174	0.0820	-0.7256	-0.0127	0.5198	0.0017	05.35	-00.01	-0.0018	0.0002	0.0032	180.0	0.0017
080	0.442	0.700	04.31	0.6269	-0.0068	0.0641	-0.6301	-0.0151	0.3929	0.0017	04.31	-00.01	-0.0023	0.0001	0.0029	180.0	0.0022
081	0.442	0.701	03.25	0.5110	-0.0057	0.0528	-0.5132	-0.0221	0.2609	0.0017	03.25	-00.01	-0.0012	0.0005	0.0026	180.0	0.0011
082	0.442	0.701	01.14	0.2834	-0.0028	0.0398	-0.2843	-0.0326	0.0802	0.0016	01.14	-00.01	-0.0012	0.0001	0.0015	180.0	0.0011
083	0.442	0.701	-00.97	0.0520	0.0059	0.0353	-0.0515	-0.0346	0.0027	0.0017	-00.97	-00.01	-0.0002	0.0001	0.0016	180.0	0.0001
084	0.440	0.700	-03.08	-0.1764	0.0176	0.0393	0.1782	-0.0283	0.0310	0.0015	-03.08	-00.01	0.0006	0.0002	0.0017	180.0	-0.0007
087	0.440	0.701	07.27	0.7819	-0.0493	0.1181	-0.7907	-0.0163	0.6113	0.0019	07.27	-00.01	-0.0027	0.0007	0.0027	180.0	0.0026

TABLE 2(D)
 CLEAN AIRCRAFT
 ETR = 0° ETRCT) = +1/2°

SER	REVW.	INCH.	JINC.D.	LIFT.	PITCH.	DRAG	NORMAL	AXIAL.	CLSQ.	BASE.	AINC.	SLIP.	CROSS.	YAW M.	ROLL M	RANG.	SIDE
088	0.440	0.501	06.76	0.7584	-0.0352	0.1035	-0.7654	-0.0115	0.5751	0.0019	06.76	-00.01	-0.0027	0.0006	0.0024	180.0	0.002
088	0.440	0.501	06.76	0.7584	-0.0352	0.1035	-0.7654	-0.0115	0.5751	0.0019	06.76	-00.01	-0.0027	0.0006	0.0024	180.0	0.002
090	0.440	0.499	06.25	0.7212	-0.0249	0.0903	-0.7268	-0.0094	0.5200	0.0018	06.25	-00.01	-0.0032	0.0005	0.0022	180.0	0.003
091	0.440	0.501	05.74	0.6802	-0.0182	0.0796	-0.6849	-0.0092	0.4626	0.0019	05.74	-00.01	-0.0030	0.0005	0.0021	180.0	0.002
092	0.437	0.499	05.23	0.6304	-0.0142	0.0695	-0.6342	-0.0101	0.3973	0.0017	05.23	-00.01	-0.0025	0.0005	0.0024	180.0	0.002
093	0.440	0.499	04.19	0.5392	-0.0105	0.0564	-0.5420	-0.0151	0.2906	0.0016	04.19	-00.01	-0.0017	0.0005	0.0026	180.0	0.001
094	0.440	0.501	03.16	0.4455	-0.0078	0.0473	-0.4475	-0.0210	0.1983	0.0017	03.16	-00.01	-0.0012	0.0004	0.0024	180.0	0.001
095	0.440	0.501	04.09	0.2499	-0.0005	0.0375	-0.2507	-0.0311	0.0624	0.0017	04.09	-00.01	-0.0005	0.0002	0.0018	180.0	0.000
096	0.440	0.499	-00.98	0.0464	0.0095	0.0339	-0.0459	-0.0333	0.0020	0.0015	-00.98	-00.01	0.0003	0.0001	0.0016	180.0	-0.000
097	0.440	0.501	-03.05	-0.1575	0.0222	0.0375	0.1592	-0.0276	0.0247	0.0015	-03.05	-00.01	0.0014	0.0002	0.0019	180.0	-0.001

TABLE 2(C)
 CLEAR AIRCRAFT
 ETR = 0° ETRACT = +1 1/2°

SER	REYN.	BACH.	INCID.	LIFT.	PITCH.	DRAW	NORMAL	AXIAL.	CLSQ.	BASE.	RJIC.	SLIP.	CROSS.	YAW M.	ROLL M	RANG.	SIDE F
002	0.455	0.900	07.42	0.8529	-0.1083	0.1699	-0.8679	-0.0560	0.7274	0.0023	07.42	-00.01	-0.0010	0.0011	-0.0004	179.9	0.0010
003	0.455	0.899	06.90	0.8209	-0.1144	0.1552	-0.8337	-0.0533	0.6737	0.0022	06.90	-00.01	-0.0001	0.0012	-0.0008	179.9	0.0000
004	0.455	0.899	06.37	0.7865	-0.1200	0.1426	-0.7976	-0.0520	0.6185	0.0024	06.37	-00.01	-0.0002	0.0011	-0.0019	179.9	0.0001
005	0.455	0.899	05.84	0.7528	-0.1222	0.1303	-0.7623	-0.0504	0.5667	0.0025	05.84	-00.01	0.0021	0.0017	-0.0012	179.9	-0.0022
006	0.455	0.899	05.32	0.7203	-0.1265	0.1196	-0.7283	-0.0499	0.5187	0.0024	05.32	-00.01	0.0004	0.0014	-0.0010	179.9	-0.0005
007	0.455	0.899	04.27	0.6459	-0.1262	0.1006	-0.6517	-0.0500	0.4171	0.0022	04.27	-00.01	0.0005	0.0014	0.0001	180.0	-0.0006
008	0.455	0.899	03.22	0.5534	-0.1169	0.0845	-0.5574	-0.0511	0.3061	0.0021	03.22	-00.01	0.0010	0.0008	0.0006	180.0	-0.0011
009	0.457	0.900	01.11	0.3300	-0.0960	0.0601	-0.3312	-0.0516	0.1087	0.0021	01.11	-00.01	0.0037	0.0023	0.0009	180.0	-0.0038
010	0.457	0.900	-01.03	0.0604	-0.0586	0.0484	-0.0597	-0.0474	0.0036	0.0021	-01.03	-00.01	0.0051	0.0023	0.0012	180.0	-0.0052
011	0.457	0.901	-03.16	-0.2415	-0.0071	0.0570	-0.2442	-0.0418	0.0581	0.0019	-03.16	-00.02	0.0067	0.0026	0.0014	180.0	-0.0068
014	0.457	0.879	07.44	0.8277	-0.0706	0.1562	-0.8411	-0.0455	0.6850	0.0021	07.44	-00.01	-0.0019	0.0013	0.0012	180.0	0.0018
015	0.457	0.879	06.90	0.8191	-0.0706	0.1482	-0.8310	-0.0465	0.6707	0.0023	06.90	-00.01	-0.0008	0.0011	-0.0005	179.9	0.0007
016	0.455	0.880	06.38	0.7864	-0.0728	0.1353	-0.7967	-0.0448	0.6183	0.0023	06.38	-00.01	0.0005	0.0012	-0.0011	179.9	-0.0006
017	0.458	0.881	05.85	0.7531	-0.0767	0.1240	-0.7620	-0.0442	0.5672	0.0024	05.85	-00.01	0.0010	0.0015	-0.0012	179.9	-0.0011
018	0.458	0.881	05.33	0.7202	-0.0793	0.1136	-0.7277	-0.0439	0.5186	0.0023	05.33	-00.01	0.0004	0.0011	-0.0006	179.9	-0.0005
019	0.460	0.860	04.29	0.6460	-0.0704	0.0958	-0.6515	-0.0451	0.4172	0.0021	04.29	-00.01	0.0008	0.0015	-0.0002	179.9	-0.0009
020	0.460	0.860	03.25	0.5598	-0.0696	0.0793	-0.5635	-0.0453	0.3132	0.0022	03.25	-00.02	0.0025	0.0021	0.0008	180.0	-0.0026
021	0.458	0.879	01.14	0.3510	-0.0784	0.0549	-0.3521	-0.0462	0.1230	0.0018	01.14	-00.02	0.0034	0.0028	0.0010	180.0	-0.0035
022	0.458	0.880	-01.00	0.0834	-0.0503	0.0438	-0.0827	-0.0433	0.0069	0.0019	-01.00	-00.02	0.0046	0.0024	0.0013	180.0	-0.0047
023	0.458	0.879	-03.16	-0.2338	-0.0124	0.0511	0.2361	-0.0363	0.0545	0.0019	-03.16	-00.02	0.0072	0.0029	0.0011	180.0	-0.0073
026	0.460	0.861	07.40	0.8125	-0.1014	0.1528	-0.8235	-0.0446	0.6801	0.0023	07.40	-00.01	-0.0002	0.0008	0.0045	180.0	0.0001
027	0.460	0.861	06.93	0.7984	-0.0996	0.1378	-0.8073	-0.0382	0.6374	0.0022	06.93	-00.01	-0.0009	0.0013	0.0007	180.0	0.0008
028	0.460	0.859	06.38	0.7975	-0.1087	0.1330	-0.8075	-0.0415	0.6359	0.0020	06.38	-00.01	-0.0003	0.0012	-0.0008	179.9	0.0002
029	0.460	0.861	05.86	0.7663	-0.1141	0.1207	-0.7747	-0.0397	0.5871	0.0022	05.86	-00.01	-0.0003	0.0011	-0.0008	179.9	0.0002
030	0.460	0.860	05.34	0.7304	-0.1100	0.1091	-0.7375	-0.0383	0.5335	0.0023	05.34	-00.01	0.0006	0.0013	-0.0006	179.9	-0.0007
031	0.460	0.861	04.31	0.6552	-0.0956	0.0908	-0.6603	-0.0392	0.4292	0.0021	04.31	-00.01	0.0005	0.0015	-0.0001	179.9	-0.0006
032	0.460	0.863	03.27	0.5691	-0.0838	0.0749	-0.5725	-0.0403	0.3236	0.0021	03.27	-00.01	0.0019	0.0017	0.0008	180.0	-0.0020
033	0.457	0.860	01.16	0.3633	-0.0819	0.0514	-0.3644	-0.0422	0.1319	0.0019	01.16	-00.02	0.0030	0.0023	0.0011	180.0	-0.0031
034	0.458	0.859	-00.99	0.0823	-0.0368	0.0402	-0.0817	-0.0399	0.0067	0.0018	-00.99	-00.02	0.0041	0.0024	0.0010	180.0	-0.0042
035	0.460	0.861	-03.16	-0.2240	-0.0158	0.0465	0.2261	-0.0325	0.0500	0.0017	-03.16	-00.01	0.0064	0.0025	0.0013	180.0	-0.0065
040	0.458	0.841	07.38	0.8159	-0.1155	0.1499	-0.8285	-0.0417	0.6656	0.0021	07.38	-00.01	0.0010	0.0014	0.0037	180.0	-0.0011
041	0.462	0.839	06.91	0.7920	-0.0766	0.1374	-0.8029	-0.0393	0.6271	0.0019	06.91	-00.01	0.0002	0.0012	0.0028	180.0	-0.0003
043	0.462	0.841	06.94	0.7920	-0.0766	0.1374	-0.8029	-0.0393	0.6271	0.0019	06.91	-00.01	0.0002	0.0012	0.0028	180.0	-0.0003
043	0.462	0.841	06.42	0.7834	-0.0618	0.1267	-0.7928	-0.0364	0.6136	0.0019	06.42	-00.01	-0.0016	0.0008	0.0027	180.0	0.0015
044	0.462	0.841	05.87	0.7777	-0.1059	0.1172	-0.7857	-0.0350	0.6047	0.0021	05.87	-00.01	-0.0013	0.0011	-0.0007	179.9	0.0013
045	0.458	0.839	05.36	0.7429	-0.0972	0.1067	-0.7497	-0.0348	0.5518	0.0021	05.36	-00.01	0.0006	0.0014	-0.0003	179.9	-0.0007

TABLE 2 (C)
CLEAR AIRCRAFT
ETA = 0° ETRKT = +1 1/2°

SER	REYN.	KACH.	INCID.	LIFT.	PITCH.	DRAW	NORMAL	AXIAL.	CLSO.	BASE.	AIHC.	SLIP.	CROSS.	YAN M.	ROLL M	RANG.	SIDE F
046	0.462	0.841	04.32	0.6683	-0.0817	0.0864	-0.6730	-0.0336	0.4465	0.0022	04.32	-00.01	0.0008	0.0015	0.0002	180.0	-0.0009
047	0.462	0.840	03.29	0.5855	-0.0577	0.0698	-0.5886	-0.0341	0.3427	0.0021	03.29	-00.01	0.0018	0.0016	0.0008	180.0	-0.0019
048	0.462	0.840	01.17	0.3588	-0.0459	0.0481	-0.3598	-0.0388	0.1286	0.0020	01.17	-00.02	0.0031	0.0025	0.0012	180.0	-0.0032
049	0.462	0.840	-00.99	0.0764	-0.0294	0.0389	-0.0758	-0.0384	0.0057	0.0019	-00.99	-00.01	0.0044	0.0023	0.0010	180.0	-0.0045
050	0.462	0.839	-03.15	-0.2079	-0.0183	0.0430	0.2099	-0.0299	0.0431	0.0017	-03.15	-00.01	0.0054	0.0024	0.0012	180.0	-0.0055
053	0.455	0.801	07.38	0.8329	-0.1134	0.1450	-0.8447	-0.0349	0.6936	0.0019	07.38	-00.01	0.0008	0.0011	0.0009	180.0	-0.0009
054	0.455	0.799	06.87	0.8112	-0.1077	0.1319	-0.8213	-0.0317	0.6580	0.0022	06.87	-00.01	0.0019	0.0016	0.0029	180.0	-0.0020
055	0.457	0.798	06.37	0.7919	-0.0990	0.1214	-0.8006	-0.0308	0.6270	0.0020	06.37	-00.01	0.0040	0.0015	0.0037	180.0	-0.0011
056	0.458	0.802	05.87	0.7846	-0.0908	0.1108	-0.7919	-0.0278	0.6155	0.0021	05.87	-00.01	0.0013	0.0014	0.0020	180.0	-0.0014
057	0.457	0.798	05.37	0.7665	-0.0855	0.0995	-0.7726	-0.0252	0.5875	0.0020	05.37	-00.01	0.0010	0.0014	0.0004	180.0	-0.0010
058	0.455	0.799	04.35	0.6958	-0.0540	0.0802	-0.7000	-0.0250	0.4840	0.0022	04.35	-00.01	0.0017	0.0018	0.0007	180.0	-0.0018
059	0.455	0.800	03.30	0.5901	-0.0394	0.0626	-0.5928	-0.0267	0.3481	0.0018	03.30	-00.01	0.0029	0.0021	0.0016	180.0	-0.0030
060	0.455	0.800	01.16	0.3295	-0.0301	0.0429	-0.3304	-0.0345	0.1085	0.0018	01.16	-00.01	0.0039	0.0023	0.0011	180.0	-0.0040
061	0.455	0.799	-00.99	0.0708	-0.0228	0.0365	-0.0702	-0.0359	0.0049	0.0018	-00.99	-00.01	0.0043	0.0023	0.0009	180.0	-0.0044
062	0.458	0.799	-03.13	-0.1898	-0.0147	0.0402	0.1916	-0.0282	0.0359	0.0016	-03.13	-00.01	0.0052	0.0023	0.0012	180.0	-0.0053
063	0.473	0.751	07.38	0.8361	-0.1030	0.1377	-0.8469	-0.0272	0.6989	0.0020	07.38	-00.01	0.0011	0.0020	0.0016	180.0	-0.0012
064	0.471	0.750	06.88	0.8173	-0.0837	0.1254	-0.8025	-0.0245	0.6679	0.0020	06.88	-00.01	0.0010	0.0020	0.0018	180.0	-0.0011
065	0.473	0.750	06.39	0.7944	-0.0608	0.1137	-0.8023	-0.0225	0.6311	0.0020	06.39	-00.01	0.0024	0.0018	0.0014	180.0	-0.0029
066	0.473	0.750	05.88	0.7817	-0.0688	0.1022	-0.7882	-0.0196	0.6110	0.0020	05.88	-00.01	0.0032	0.0020	0.0043	180.0	-0.0033
066	0.473	0.751	05.40	0.7379	-0.0191	0.0885	-0.7430	-0.0168	0.5444	0.0019	05.40	-00.01	0.0028	0.0020	0.0033	180.0	-0.0029
067	0.473	0.751	04.35	0.6777	-0.0308	0.0715	-0.6813	-0.0179	0.4591	0.0019	04.35	-00.01	0.0018	0.0017	0.0016	180.0	-0.0019
068	0.471	0.749	03.28	0.5530	-0.0286	0.0568	-0.5555	-0.0230	0.3056	0.0020	03.28	-00.01	0.0031	0.0022	0.0018	180.0	-0.0032
069	0.471	0.749	01.14	0.3071	-0.0270	0.0420	-0.3080	-0.0342	0.0942	0.0016	01.14	-00.01	0.0037	0.0024	0.0012	180.0	-0.0038
070	0.473	0.750	-00.99	0.0660	-0.0191	0.0370	-0.0654	-0.0365	0.0043	0.0017	-00.99	-00.01	0.0046	0.0023	0.0012	180.0	-0.0047
071	0.473	0.750	-03.11	-0.1759	-0.0084	0.0407	0.1777	-0.0295	0.0308	0.0016	-03.11	-00.01	0.0056	0.0024	0.0014	180.0	-0.0057
074	0.455	0.701	07.36	0.8242	-0.0790	0.1330	-0.8346	-0.0245	0.6791	0.0018	07.36	-00.01	0.0021	0.0020	0.0036	180.0	-0.0022
075	0.455	0.699	06.85	0.8175	-0.0794	0.1202	-0.8261	-0.0197	0.6681	0.0020	06.85	-00.01	0.0021	0.0023	0.0038	180.0	-0.0022
076	0.455	0.699	06.36	0.7963	-0.0651	0.1063	-0.8032	-0.0157	0.6339	0.0018	06.36	-00.01	0.0029	0.0023	0.0039	180.0	-0.0030
077	0.453	0.701	05.85	0.7701	-0.0520	0.0951	-0.7759	-0.0140	0.5930	0.0021	05.85	-00.01	0.0028	0.0023	0.0038	180.0	-0.0029
078	0.455	0.700	05.34	0.7313	-0.0410	0.0840	-0.7360	-0.0137	0.5347	0.0019	05.34	-00.01	0.0027	0.0023	0.0028	180.0	-0.0028
079	0.455	0.700	04.30	0.6364	-0.0302	0.0662	-0.6397	-0.0162	0.4048	0.0020	04.30	-00.01	0.0032	0.0025	0.0023	180.0	-0.0033
080	0.455	0.700	03.24	0.5227	-0.0294	0.0533	-0.5250	-0.0218	0.2730	0.0019	03.24	-00.01	0.0037	0.0022	0.0020	180.0	-0.0038
081	0.455	0.699	01.13	0.2929	-0.0255	0.0401	-0.2937	-0.0325	0.0856	0.0019	01.13	-00.01	0.0029	0.0021	0.0010	180.0	-0.0030
082	0.457	0.700	-00.99	0.0627	-0.0169	0.0364	-0.0622	-0.0359	0.0038	0.0016	-00.99	-00.01	0.0047	0.0024	0.0010	180.0	-0.0048
083	0.455	0.699	-03.10	-0.1668	-0.0052	0.0397	0.1686	-0.0292	0.0277	0.0015	-03.10	-00.01	0.0052	0.0023	0.0013	180.0	-0.0053
086	0.450	0.499	07.26	0.7928	-0.0704	0.1231	-0.8021	-0.0197	0.6284	0.0022	07.26	-00.01	0.0015	0.0026	0.0024	180.0	-0.0016

TABLE 2(E)
 CLEAR AIRCRAFT
 ETA = 0° ETRKT = +1 1/2°

SER	REYN.	MACH.	INCID.	LIFT.	PITCH.	DRAW	NORMAL	AXIAL.	CLSQ.	BASE.	AINC.	SLIP.	CROSS.	YAW M.	ROLL M	RANG.	SIDE F
027	0.449	0.501	06.76	0.7689	-0.0582	0.1047	-0.7760	-0.0115	0.5911	0.0020	06.76	-00.01	0.0018	0.0025	0.0020	180.0	-0.0018
028	0.449	0.502	06.25	0.7321	-0.0471	0.0916	-0.7378	-0.0091	0.5359	0.0022	06.25	-00.01	0.0013	0.0024	0.0018	180.0	-0.0014
029	0.450	0.500	05.74	0.6903	-0.0405	0.0809	-0.6950	-0.0092	0.4763	0.0022	05.74	-00.01	0.0016	0.0024	0.0017	180.0	-0.0017
030	0.452	0.501	05.22	0.6439	-0.0365	0.0712	-0.6478	-0.0102	0.4145	0.0021	05.22	-00.01	0.0020	0.0024	0.0020	180.0	-0.0021
031	0.452	0.501	04.19	0.5516	-0.0326	0.0576	-0.5545	-0.0152	0.3042	0.0020	04.19	-00.01	0.0030	0.0024	0.0024	180.0	-0.0031
032	0.452	0.500	03.15	0.4551	-0.0294	0.0482	-0.4571	-0.0211	0.2070	0.0021	03.15	-00.01	0.0035	0.0023	0.0019	180.0	-0.0036
033	0.450	0.499	01.08	0.2607	-0.0217	0.0377	-0.2615	-0.0310	0.0678	0.0019	01.08	-00.01	0.0038	0.0023	0.0012	180.0	-0.0039
034	0.471	0.502	-00.99	0.0565	-0.0122	0.0345	-0.0560	-0.0336	0.0031	0.0019	-00.99	-00.01	0.0042	0.0022	0.0013	180.0	-0.0043
035	0.471	0.499	-03.06	-0.1464	0.0001	0.0364	0.1481	-0.0268	0.0213	0.0018	-03.06	-00.01	0.0050	0.0022	0.0016	180.0	-0.0051

TABLE 2(F)
CLEAN AIRCRAFT
ETA = 0° ETRACT = +2 1/2°

SER	REYN.	KACH.	INC/D.	LIFT.	PITCH.	DRAW	NORMAL	AXIAL.	CLSQ.	BASE.	RINC.	SLIP.	CROSS.	YAN M.	ROLL M	RANG.	SIDE F
002	0.455	0.900	07.41	0.8574	-0.1181	0.1681	-0.8720	-0.0538	0.7349	0.0023	07.41	(0.00	-0.0046	-0.0010	0.0002	180.0	0.0045
003	0.452	0.898	06.89	0.8246	-0.1243	0.1534	-0.8371	-0.0511	0.6798	0.0023	06.89	(0.00	-0.0050	-0.0010	0.0000	180.0	0.0049
004	0.455	0.899	06.36	0.7900	-0.1300	0.1408	-0.8008	-0.0501	0.6240	0.0023	06.36	(0.00	-0.0045	-0.0012	-0.0011	179.9	0.0044
005	0.455	0.898	05.83	0.7575	-0.1360	0.1280	-0.7667	-0.0482	0.5738	0.0021	05.83	(0.00	-0.0041	-0.0009	-0.0007	179.9	0.0040
006	0.455	0.898	05.31	0.7259	-0.1402	0.1180	-0.7338	-0.0480	0.5269	0.0023	05.31	(0.00	-0.0030	-0.0006	-0.0004	179.9	0.0029
007	0.457	0.904	04.26	0.6523	-0.1463	0.1009	-0.6581	-0.0497	0.4253	0.0025	04.26	(0.01	-0.0028	-0.0004	0.0007	180.0	0.0027
008	0.455	0.901	03.21	0.5614	-0.1411	0.0838	-0.5654	-0.0500	0.3150	0.0022	03.21	(0.01	-0.0010	0.0006	0.0011	180.0	0.0009
009	0.457	0.901	01.09	0.3356	-0.1174	0.0587	-0.3368	-0.0502	0.1125	0.0022	01.09	(0.01	-0.0010	0.0001	0.0014	180.0	0.0009
010	0.455	0.899	-01.04	0.0692	-0.0784	0.0475	-0.0684	-0.0486	0.0047	0.0021	-01.04	(0.01	0.0002	0.0003	0.0016	180.0	-0.0003
011	0.455	0.899	-03.18	-0.2360	-0.0270	0.0574	0.2387	-0.0423	0.0555	0.0020	-03.18	(0.01	0.0029	0.0005	0.0019	180.0	-0.0030
014	0.457	0.879	07.42	0.8306	-0.0927	0.1546	-0.8437	-0.0440	0.6897	0.0020	07.42	(0.00	-0.0065	-0.0011	0.0016	180.0	0.0064
015	0.457	0.880	06.89	0.8196	-0.1170	0.1483	-0.8316	-0.0468	0.6717	0.0021	06.89	(0.00	-0.0042	-0.0008	0.0003	180.0	0.0041
016	0.458	0.882	06.37	0.7890	-0.1217	0.1358	-0.7993	-0.0450	0.6224	0.0024	06.37	(0.00	-0.0042	-0.0011	-0.0005	179.9	0.0041
017	0.457	0.880	05.84	0.7571	-0.1273	0.1229	-0.7658	-0.0430	0.5732	0.0021	05.84	(0.00	-0.0024	-0.0006	-0.0007	179.9	0.0023
018	0.455	0.880	05.32	0.7249	-0.1319	0.1128	-0.7323	-0.0429	0.5254	0.0021	05.32	(0.00	-0.0042	-0.0010	-0.0002	179.9	0.0041
019	0.458	0.881	04.27	0.6557	-0.1314	0.0944	-0.6610	-0.0432	0.4299	0.0021	04.27	(0.00	-0.0039	-0.0009	0.0002	180.0	0.0038
020	0.458	0.881	03.23	0.5678	-0.1211	0.0781	-0.5714	-0.0438	0.3222	0.0022	03.23	(0.00	-0.0011	-0.0002	0.0013	180.0	0.0010
021	0.458	0.880	01.12	0.3585	-0.0985	0.0545	-0.3596	-0.0455	0.1284	0.0020	01.12	(0.01	0.0003	0.0003	0.0014	180.0	-0.0004
022	0.458	0.879	-01.02	0.0899	-0.0697	0.0422	-0.0892	-0.0417	0.0080	0.0021	-01.02	(0.01	0.0008	0.0003	0.0017	180.0	-0.0009
023	0.458	0.880	-03.18	-0.2301	-0.0304	0.0496	0.2324	-0.0350	0.0528	0.0019	-03.18	(0.01	0.0042	0.0009	0.0016	180.0	-0.0043
026	0.460	0.860	07.39	0.8216	-0.1198	0.1536	-0.8246	-0.0446	0.6749	0.0021	07.39	(0.00	-0.0024	-0.0002	0.0038	180.0	0.0023
027	0.460	0.861	06.91	0.8110	-0.0861	0.1424	-0.8223	-0.0417	0.6576	0.0020	06.91	(0.00	-0.0064	-0.0011	0.0010	180.0	0.0063
028	0.457	0.860	06.37	0.7908	-0.1204	0.1317	-0.8086	-0.0401	0.6380	0.0021	06.37	(0.00	-0.0037	-0.0008	-0.0003	179.9	0.0036
029	0.457	0.859	05.85	0.7697	-0.1241	0.1204	-0.7781	-0.0392	0.5924	0.0021	05.85	(0.00	-0.0033	-0.0008	-0.0003	179.9	0.0032
030	0.457	0.860	05.33	0.7364	-0.1266	0.1085	-0.7434	-0.0375	0.5423	0.0022	05.33	(0.00	-0.0039	-0.0007	-0.0001	179.9	0.0038
031	0.457	0.861	04.29	0.6636	-0.1166	0.0895	-0.6685	-0.0374	0.4402	0.0022	04.29	(0.00	-0.0032	-0.0006	0.0003	180.0	0.0031
032	0.457	0.860	03.25	0.5793	-0.1033	0.0729	-0.5826	-0.0379	0.3355	0.0021	03.25	(0.01	-0.0023	-0.0002	0.0013	180.0	0.0023
033	0.457	0.860	01.14	0.3704	-0.0804	0.0496	-0.3714	-0.0401	0.1371	0.0021	01.14	(0.01	-0.0003	0.0001	0.0016	180.0	0.0002
034	0.457	0.861	-01.01	0.0899	-0.0565	0.0395	-0.0893	-0.0392	0.0080	0.0019	-01.01	(0.01	0.0011	0.0004	0.0015	180.0	-0.0002
035	0.457	0.860	-03.17	-0.2184	-0.0345	0.0497	0.2205	-0.0316	0.0475	0.0020	-03.17	(0.01	0.0025	0.0006	0.0018	180.0	-0.0026
038	0.457	0.840	07.38	0.8269	-0.1255	0.1499	-0.8294	-0.0406	0.6836	0.0018	07.38	(0.00	-0.0028	-0.0004	0.0035	180.0	0.0027
039	0.457	0.839	06.89	0.8089	-0.1056	0.1371	-0.8196	-0.0373	0.6542	0.0018	06.89	(0.00	-0.0031	-0.0005	0.0023	180.0	0.0030
040	0.455	0.841	06.37	0.8003	-0.1123	0.1281	-0.8097	-0.0363	0.6404	0.0021	06.37	(0.00	-0.0038	-0.0009	0.0008	180.0	0.0037
041	0.457	0.839	05.85	0.7863	-0.1242	0.1169	-0.7942	-0.0341	0.6181	0.0020	05.85	(0.00	-0.0031	-0.0006	-0.0002	179.9	0.0030
042	0.455	0.841	05.34	0.7511	-0.1204	0.1063	-0.7578	-0.0338	0.5640	0.0022	05.34	(0.00	-0.0032	-0.0008	0.0002	180.0	0.0031
043	0.455	0.841	04.31	0.6772	-0.1041	0.0878	-0.6820	-0.0346	0.4585	0.0021	04.31	(0.00	-0.0028	-0.0006	0.0005	180.0	0.0027

TABLE 2(F)
 CLEAN AIRCRAFT
 ETA = 0° ETRACT = +2 1/2°

SER	REYN.	MACH.	JNC'D.	LIFT.	PITCH.	DRAG	NORMAL	AXIAL.	CLSQ.	BASE.	AINC.	SLIP.	CROSS.	YAW M.	ROLL M	RANG.	SIDE F
044	0.455	0.841	03.27	0.5929	-0.0896	0.0708	-0.5961	-0.0348	0.3514	0.0021	03.27	-00.01	-0.0028	-0.0003	0.0012	180.0	0.0027
045	0.455	0.841	01.15	0.3661	-0.0662	0.0468	-0.3671	-0.0375	0.1340	0.0019	01.15	-00.01	-0.0009	0.0004	0.0016	180.0	-0.0010
046	0.455	0.840	-01.00	0.0851	-0.0481	0.0376	-0.0845	-0.0372	0.0071	0.0019	-01.00	-00.01	0.0004	0.0002	0.0015	180.0	-0.0005
047	0.457	0.838	-03.16	-0.2022	-0.0368	0.0409	0.2040	-0.0281	0.0408	0.0016	-03.16	-00.01	0.0016	0.0006	0.0017	180.0	-0.0017
050	0.453	0.799	07.39	0.8342	-0.1042	0.1433	-0.8459	-0.0329	0.6958	0.0019	07.39	00.00	-0.0031	-0.0003	0.0021	180.0	0.0030
051	0.453	0.798	06.87	0.8214	-0.1156	0.1312	-0.8313	-0.0303	0.6746	0.0017	06.87	-00.01	-0.0029	0.0001	0.0027	180.0	0.0028
052	0.455	0.801	06.36	0.8024	-0.1093	0.1206	-0.8110	-0.0291	0.6438	0.0018	06.36	00.00	-0.0018	-0.0002	0.0029	180.0	0.0017
053	0.455	0.804	05.86	0.7905	-0.1014	0.1100	-0.7977	-0.0266	0.6247	0.0020	05.86	00.00	-0.0036	-0.0008	0.0021	180.0	0.0038
054	0.455	0.800	05.36	0.7780	-0.0973	0.1007	-0.7841	-0.0255	0.6052	0.0020	05.36	00.00	-0.0043	-0.0008	0.0006	180.0	0.0042
055	0.455	0.800	04.34	0.7044	-0.0744	0.0796	-0.7085	-0.0241	0.4960	0.0020	04.34	-00.01	-0.0035	-0.0004	0.0011	180.0	0.0034
056	0.453	0.799	03.29	0.5991	-0.0584	0.0609	-0.6017	-0.0246	0.3588	0.0018	03.29	-00.01	-0.0019	0.0003	0.0022	180.0	0.0018
057	0.455	0.800	01.15	0.3373	-0.0485	0.0424	-0.3382	-0.0338	0.1136	0.0019	01.15	-00.01	-0.0011	0.0004	0.0016	180.0	0.0007
058	0.455	0.800	-01.00	0.0764	-0.0404	0.0363	-0.0759	-0.0359	0.0059	0.0018	-01.00	-00.01	-0.0006	0.0003	0.0015	180.0	0.0009
059	0.455	0.801	-03.14	-0.1849	-0.0328	0.0387	0.1867	-0.0270	0.0340	0.0016	-03.14	-00.01	0.0012	0.0003	0.0017	180.0	-0.0013
062	0.471	0.750	07.36	0.8375	-0.1199	0.1364	-0.8482	-0.0261	0.7013	0.0018	07.36	00.00	-0.0022	-0.0002	0.0026	180.0	0.0021
063	0.471	0.749	06.88	0.8231	-0.0950	0.1227	-0.8320	-0.0212	0.6774	0.0020	06.88	00.00	-0.0028	-0.0004	0.0034	180.0	0.0027
064	0.471	0.749	06.37	0.8056	-0.0870	0.1126	-0.8132	-0.0205	0.6488	0.0020	06.37	00.00	-0.0008	0.0003	0.0042	180.0	0.0007
065	0.471	0.749	05.87	0.7884	-0.0798	0.1008	-0.7947	-0.0176	0.6215	0.0020	05.87	00.00	-0.0006	0.0001	0.0043	180.0	0.0005
066	0.473	0.752	05.39	0.7532	-0.0359	0.0898	-0.7584	-0.0166	0.5672	0.0020	05.39	00.00	-0.0014	-0.0002	0.0031	180.0	0.0013
067	0.471	0.749	04.34	0.6855	-0.0497	0.0709	-0.6890	-0.0169	0.4697	0.0020	04.34	00.00	-0.0021	-0.0002	0.0020	180.0	0.0020
068	0.468	0.748	03.27	0.5576	-0.0466	0.0544	-0.5599	-0.0209	0.3107	0.0016	03.27	-00.01	-0.0007	0.0003	0.0022	180.0	0.0006
069	0.473	0.752	01.13	0.3149	-0.0445	0.0408	-0.3157	-0.0326	0.0990	0.0020	01.13	-00.01	-0.0000	0.0004	0.0016	180.0	-0.0001
070	0.471	0.750	-01.00	0.0732	-0.0356	0.0355	-0.0727	-0.0352	0.0052	0.0016	-01.00	-00.01	0.0003	0.0001	0.0016	180.0	-0.0004
071	0.471	0.749	-03.12	-0.1703	-0.0253	0.0380	0.1720	-0.0272	0.0289	0.0015	-03.12	-00.01	0.0014	0.0001	0.0017	180.0	-0.0019
074	0.457	0.700	07.36	0.8192	-0.0820	0.1305	-0.8293	-0.0227	0.6710	0.0018	07.36	00.00	-0.0031	-0.0001	0.0040	180.0	0.0030
075	0.457	0.702	06.85	0.8273	-0.0983	0.1204	-0.8359	-0.0190	0.6843	0.0019	06.85	-00.01	-0.0012	0.0004	0.0041	180.0	0.0011
076	0.457	0.701	06.36	0.7942	-0.0583	0.1059	-0.8012	-0.0154	0.6307	0.0019	06.36	-00.01	-0.0006	0.0006	0.0046	180.0	0.0009
077	0.457	0.700	05.84	0.7766	-0.0699	0.0951	-0.7814	-0.0137	0.6016	0.0019	05.84	00.00	0.0001	0.0003	0.0041	180.0	-0.0002
078	0.457	0.700	05.33	0.7413	-0.0599	0.0835	-0.7459	-0.0125	0.5494	0.0018	05.33	-00.01	-0.0019	0.0002	0.0032	180.0	0.0018
079	0.457	0.699	04.29	0.6440	-0.0485	0.0638	-0.6471	-0.0138	0.4146	0.0017	04.29	-00.01	-0.0015	0.0004	0.0028	180.0	0.0014
080	0.457	0.701	03.23	0.5300	-0.0472	0.0523	-0.5322	-0.0206	0.2807	0.0018	03.23	-00.01	-0.0007	0.0005	0.0026	180.0	0.0006
081	0.457	0.699	01.12	0.3004	-0.0424	0.0395	-0.3012	-0.0321	0.0901	0.0016	01.12	-00.01	-0.0004	0.0003	0.0015	180.0	0.0003
082	0.457	0.701	-01.00	0.0699	-0.0330	0.0383	-0.0694	-0.0350	0.0048	0.0016	-01.00	-00.01	-0.0002	0.0001	0.0015	180.0	0.0001
083	0.457	0.700	-03.11	-0.1600	-0.0213	0.0380	0.1617	-0.0279	0.0254	0.0015	-03.11	-00.01	0.0014	0.0003	0.0017	180.0	-0.0015
086	0.450	0.499	07.25	0.8012	-0.0871	0.1204	-0.8101	-0.0165	0.6418	0.0018	07.25	-00.01	-0.0022	0.0008	0.0027	180.0	0.0021
087	0.449	0.502	06.75	0.7756	-0.0745	0.1049	-0.7827	-0.0110	0.6015	0.0019	06.75	-00.01	-0.0024	0.0007	0.0024	180.0	0.0023

TABLE 2(F)
 CLEAR AIRCRAFT
 ETA = (° ETRACT) = +2 1/2°

SER	REYN.	MACH.	INCID.	LIFT.	PITCH.	DRAG	NORMAL	AXIAL	CLSQ.	BASE.	RIINC.	SLIP.	CROSS.	YAW M.	ROLL M	RANG.	SIDE F
028	0.452	0.501	06.24	0.7414	-0.0642	0.0918	-0.7471	-0.0087	0.5496	0.0020	06.24	-00.01	-0.0026	0.0005	0.0022	180.0	0.0025
029	0.447	0.498	05.73	0.6950	-0.0373	0.0799	-0.6996	-0.0084	0.4828	0.0018	05.73	-00.01	-0.0023	0.0004	0.0020	180.0	0.0022
030	0.450	0.500	05.21	0.6514	-0.0334	0.0708	-0.6553	-0.0094	0.4243	0.0020	05.21	-00.01	-0.0020	0.0005	0.0024	180.0	0.0019
031	0.449	0.501	04.18	0.5581	-0.0491	0.0569	-0.5608	-0.0141	0.3112	0.0020	04.18	-00.01	-0.0012	0.0005	0.0027	180.0	0.0011
032	0.450	0.499	03.14	0.4614	-0.0453	0.0476	-0.4634	-0.0202	0.2128	0.0020	03.14	-00.01	-0.0012	0.0002	0.0024	180.0	0.0011
033	0.450	0.500	01.07	0.2666	-0.0370	0.0364	-0.2673	-0.0298	0.0710	0.0016	01.07	-00.01	-0.0004	0.0004	0.0016	180.0	0.0003
034	0.450	0.500	-01.00	0.0637	-0.0268	0.0328	-0.0632	-0.0322	0.0039	0.0018	-01.00	-00.01	0.0003	0.0002	0.0017	180.0	-0.0004
035	0.449	0.501	-03.07	-0.1395	-0.0140	0.0352	0.1411	-0.0262	0.0193	0.0016	-03.07	-00.01	0.0014	0.0003	0.0018	180.0	-0.0015

TABLE 2 (G)
CLEAN AIRCRAFT
ETA = 0° ETR(T) = +3 1/2°

SER	REYN.	HACH.	INCLD.	LIFT.	PITCH.	DRAG	NORMAL	AXIAL.	CLSQ.	BASE.	RINC.	SLIP.	CROSS.	YAW M.	ROLL M	RANG.	SIDE F
002	0.455	0.899	07.41	0.8517	-0.1177	0.1696	-0.8666	-0.0558	0.7254	0.0024	07.41	(0.02	0.0000	0.0019	0.0000	180.0	-0.0001
003	0.452	0.900	06.89	0.8207	-0.1235	0.1553	-0.8135	-0.0532	0.6735	0.0025	06.89	(0.01	0.0004	0.0017	-0.0003	179.9	-0.0005
004	0.452	0.898	06.36	0.7853	-0.1304	0.1411	-0.7962	-0.0508	0.6166	0.0025	06.36	(0.01	0.0011	0.0017	-0.0009	179.9	-0.0012
005	0.452	0.898	05.83	0.7546	-0.1372	0.1289	-0.7638	-0.0491	0.5693	0.0024	05.83	(0.01	0.0013	0.0016	-0.0006	179.9	-0.0014
006	0.452	0.900	05.31	0.7234	-0.1424	0.1188	-0.7314	-0.0489	0.5233	0.0025	05.31	(0.01	0.0003	0.0015	-0.0005	179.9	-0.0004
007	0.455	0.901	04.25	0.6538	-0.1554	0.1007	-0.6596	-0.0495	0.4274	0.0025	04.25	(0.01	0.0005	0.0016	0.0002	180.0	-0.0006
008	0.455	0.901	03.19	0.5698	-0.1660	0.0843	-0.5737	-0.0502	0.3245	0.0024	03.19	(0.01	0.0013	0.0019	0.0008	180.0	-0.0014
009	0.452	0.898	01.07	0.3507	-0.1458	0.0592	-0.3519	-0.0505	0.1229	0.0022	01.07	(0.02	0.0027	0.0027	0.0010	180.0	-0.0028
010	0.453	0.902	-01.07	0.0796	-0.1097	0.0486	-0.0748	-0.0477	0.0056	0.0024	-01.07	(0.02	0.0057	0.0032	0.0011	180.0	-0.0057
011	0.452	0.899	-03.20	-0.2262	-0.0572	0.0564	0.2289	-0.0415	0.0510	0.0022	-03.20	(0.02	0.0073	0.0029	0.0014	180.0	-0.0074
014	0.455	0.881	07.41	0.8289	-0.1059	0.1561	-0.8422	-0.0454	0.6869	0.0024	07.41	(0.01	-0.0029	0.0013	0.0011	180.0	0.0028
015	0.457	0.879	06.88	0.8191	-0.1231	0.1481	-0.8111	-0.0465	0.6708	0.0023	06.88	(0.02	0.0006	0.0019	-0.0003	179.9	-0.0007
016	0.455	0.881	06.36	0.7881	-0.1278	0.1375	-0.7986	-0.0468	0.6210	0.0024	06.36	(0.01	-0.0007	0.0010	-0.0009	179.9	0.0006
017	0.457	0.879	05.84	0.7577	-0.1344	0.1241	-0.7665	-0.0439	0.5741	0.0024	05.84	(0.01	0.0004	0.0013	-0.0007	179.9	-0.0005
018	0.455	0.880	05.31	0.7249	-0.1400	0.1132	-0.7323	-0.0433	0.5254	0.0023	05.31	(0.01	0.0019	0.0020	-0.0002	179.9	-0.0020
019	0.457	0.879	04.26	0.6616	-0.1486	0.0946	-0.6669	-0.0430	0.4376	0.0022	04.26	(0.02	0.0028	0.0022	0.0000	179.9	-0.0029
020	0.453	0.879	03.21	0.5798	-0.1507	0.0798	-0.5835	-0.0449	0.3361	0.0023	03.21	(0.02	0.0026	0.0022	0.0008	180.0	-0.0027
021	0.458	0.881	01.10	0.3687	-0.1305	0.0547	-0.3698	-0.0454	0.1358	0.0023	01.10	(0.02	0.0037	0.0029	0.0009	180.0	-0.0038
022	0.457	0.878	-01.04	0.0994	-0.0982	0.0419	-0.0987	-0.0417	0.0097	0.0021	-01.04	(0.02	0.0053	0.0030	0.0011	180.0	-0.0054
023	0.458	0.881	-03.20	-0.2202	-0.0592	0.0498	0.2229	-0.0353	0.0483	0.0022	-03.20	(0.02	0.0082	0.0031	0.0010	180.0	-0.0083
026	0.460	0.861	07.38	0.8193	-0.1269	0.1544	-0.8329	-0.0456	0.6711	0.0022	07.38	(0.01	0.0008	0.0017	0.0032	180.0	-0.0009
027	0.457	0.860	06.89	0.8010	-0.1071	0.1394	-0.8121	-0.0400	0.6416	0.0023	06.89	(0.01	-0.0028	0.0008	0.0012	180.0	0.0027
028	0.457	0.860	06.37	0.8008	-0.1280	0.1321	-0.8106	-0.0402	0.6412	0.0023	06.37	(0.01	-0.0006	0.0014	-0.0007	179.9	0.0005
029	0.458	0.859	05.84	0.7726	-0.1341	0.1213	-0.7810	-0.0396	0.5968	0.0024	05.84	(0.01	0.0019	0.0019	-0.0006	179.9	-0.0019
030	0.457	0.861	05.32	0.7397	-0.1394	0.1093	-0.7468	-0.0378	0.5471	0.0025	05.32	(0.01	0.0009	0.0018	-0.0002	179.9	-0.0010
031	0.457	0.861	04.27	0.6744	-0.1432	0.0913	-0.6795	-0.0384	0.4547	0.0023	04.27	(0.01	0.0005	0.0017	0.0001	180.0	-0.0005
032	0.458	0.859	03.23	0.5917	-0.1313	0.0730	-0.5950	-0.0374	0.3500	0.0021	03.23	(0.01	0.0021	0.0021	0.0008	180.0	-0.0022
033	0.457	0.861	01.12	0.3798	-0.1111	0.0512	-0.3808	-0.0415	0.1441	0.0023	01.12	(0.02	0.0042	0.0031	0.0011	180.0	-0.0042
034	0.457	0.861	-01.03	0.0984	-0.0894	0.0379	-0.0979	-0.0375	0.0096	0.0022	-01.03	(0.02	0.0054	0.0028	0.0009	180.0	-0.0055
035	0.460	0.861	-03.20	-0.2097	-0.0625	0.0443	0.2117	-0.0306	0.0438	0.0020	-03.20	(0.02	0.0066	0.0031	0.0012	180.0	-0.0067
038	0.457	0.839	07.37	0.8276	-0.1307	0.1508	-0.8403	-0.0411	0.6849	0.0022	07.37	(0.01	0.0009	0.0019	0.0026	180.0	-0.0010
039	0.457	0.839	06.86	0.8111	-0.1340	0.1389	-0.8220	-0.0398	0.6578	0.0022	06.86	(0.01	0.0033	0.0023	0.0025	180.0	-0.0034
040	0.457	0.839	06.39	0.7828	-0.0941	0.1289	-0.8027	-0.0347	0.6298	0.0021	06.39	(0.01	0.0012	0.0018	0.0006	180.0	-0.0013
041	0.455	0.841	05.84	0.7883	-0.1363	0.1171	-0.7962	-0.0340	0.6213	0.0022	05.84	(0.01	0.0012	0.0016	-0.0006	179.9	-0.0013
042	0.457	0.839	05.32	0.7593	-0.1387	0.1059	-0.7660	-0.0328	0.5765	0.0022	05.32	(0.02	0.0015	0.0021	0.0000	180.0	-0.0015
043	0.457	0.840	04.29	0.6893	-0.1321	0.0872	-0.6940	-0.0331	0.4750	0.0023	04.29	(0.01	0.0010	0.0017	0.0004	180.0	-0.0011

TABLE 2(8)
CLEAN AIRCRAFT
ETA = 0° ETRACT = +3 1/2°

SER	REYN.	MACH.	INCID.	LIFT.	PITCH.	DRAW	NORMAL	AXIAL.	CLSQ.	BASE.	RIIC.	SLIP.	CROSS.	YAW M.	ROLL M	RANG.	SIDE F
044	0.457	0.839	03.25	0.6059	-0.1163	0.0707	-0.6090	-0.0342	0.3670	0.0021	03.25	-00.02	0.0033	0.0023	0.0009	180.0	-0.0033
045	0.455	0.840	01.13	0.3756	-0.0938	0.0464	-0.3765	-0.0368	0.1410	0.0021	01.13	-00.02	0.0040	0.0030	0.0011	180.0	-0.0041
046	0.457	0.838	-01.02	0.0918	-0.0752	0.0367	-0.0912	-0.0364	0.0083	0.0020	-01.02	-00.02	0.0050	0.0033	0.0009	180.0	-0.0050
047	0.455	0.840	-03.19	-0.1935	-0.0641	0.0415	0.1954	-0.0289	0.0373	0.0019	-03.19	-00.02	0.0061	0.0028	0.0013	180.0	-0.0062
050	0.467	0.799	07.37	0.8322	-0.1217	0.1453	-0.8441	-0.0351	0.6925	0.0021	07.37	-00.01	0.0008	0.0016	0.0024	180.0	-0.0009
051	0.467	0.801	06.87	0.8228	-0.1263	0.1331	-0.8329	-0.0316	0.6768	0.0022	06.87	-00.02	0.0028	0.0026	0.0023	180.0	-0.0029
052	0.467	0.801	06.35	0.8107	-0.1335	0.1224	-0.8194	-0.0296	0.6572	0.0023	06.35	-00.01	0.0022	0.0020	0.0023	180.0	-0.0023
053	0.467	0.800	05.88	0.7951	-0.0951	0.1098	-0.8023	-0.0256	0.6321	0.0022	05.88	-00.01	-0.0006	0.0016	0.0015	180.0	0.0009
054	0.467	0.800	05.35	0.7888	-0.1232	0.1009	-0.7949	-0.0247	0.6222	0.0022	05.35	-00.01	0.0003	0.0015	0.0002	180.0	-0.0004
055	0.467	0.799	04.32	0.7184	-0.1025	0.0803	-0.7225	-0.0238	0.5160	0.0021	04.32	-00.01	0.0017	0.0021	0.0009	180.0	-0.0018
056	0.470	0.801	03.27	0.6079	-0.0866	0.0628	-0.6106	-0.0259	0.3694	0.0021	03.27	-00.02	0.0030	0.0024	0.0019	180.0	-0.0031
057	0.467	0.799	01.13	0.3463	-0.0757	0.0432	-0.3472	-0.0345	0.1198	0.0019	01.13	-00.02	0.0035	0.0027	0.0012	180.0	-0.0036
058	0.467	0.800	-01.02	0.0853	-0.0673	0.0358	-0.0847	-0.0353	0.0072	0.0020	-01.02	-00.02	0.0045	0.0028	0.0011	180.0	-0.0046
059	0.467	0.800	-03.16	-0.1756	-0.0584	0.0398	0.1775	-0.0283	0.0307	0.0017	-03.16	-00.02	0.0063	0.0029	0.0014	180.0	-0.0064
062	0.462	0.751	07.34	0.8415	-0.1385	0.1357	-0.8521	-0.0249	0.7080	0.0021	07.34	-00.01	0.0021	0.0024	0.0025	180.0	-0.0022
063	0.462	0.751	06.85	0.8272	-0.1224	0.1258	-0.8364	-0.0242	0.6841	0.0021	06.85	-00.01	0.0021	0.0022	0.0033	180.0	-0.0022
064	0.460	0.750	06.34	0.8145	-0.1221	0.1127	-0.8221	-0.0199	0.6634	0.0021	06.34	-00.01	0.0027	0.0022	0.0039	180.0	-0.0028
065	0.460	0.749	05.85	0.7967	-0.1025	0.1027	-0.8031	-0.0189	0.6346	0.0021	05.85	-00.01	0.0041	0.0024	0.0038	180.0	-0.0042
066	0.460	0.748	05.34	0.7760	-0.0942	0.0908	-0.7812	-0.0162	0.6020	0.0019	05.34	-00.01	0.0028	0.0023	0.0026	180.0	-0.0028
067	0.462	0.750	04.31	0.6967	-0.0784	0.0712	-0.7001	-0.0164	0.4851	0.0022	04.31	-00.01	0.0021	0.0022	0.0016	180.0	-0.0022
068	0.460	0.749	03.25	0.5696	-0.0748	0.0560	-0.5719	-0.0217	0.3243	0.0019	03.25	-00.02	0.0037	0.0026	0.0018	180.0	-0.0038
069	0.462	0.751	01.11	0.3245	-0.0715	0.0419	-0.3253	-0.0337	0.1052	0.0020	01.11	-00.02	0.0033	0.0025	0.0011	180.0	-0.0034
070	0.462	0.751	-01.02	0.0806	-0.0620	0.0361	-0.0800	-0.0357	0.0064	0.0019	-01.02	-00.02	0.0047	0.0027	0.0011	180.0	-0.0048
071	0.463	0.750	-03.14	-0.1590	-0.0507	0.0383	0.1607	-0.0278	0.0252	0.0017	-03.14	-00.02	0.0057	0.0028	0.0012	180.0	-0.0058
074	0.449	0.699	07.33	0.8417	-0.1247	0.1339	-0.8520	-0.0233	0.7083	0.0021	07.33	-00.01	0.0031	0.0026	0.0035	180.0	-0.0031
075	0.449	0.700	06.83	0.8327	-0.1225	0.1211	-0.8413	-0.0191	0.6934	0.0021	06.83	-00.01	0.0033	0.0026	0.0042	180.0	-0.0034
076	0.449	0.701	06.34	0.8092	-0.0955	0.1070	-0.8162	-0.0149	0.6547	0.0021	06.34	-00.01	0.0035	0.0028	0.0044	180.0	-0.0036
077	0.449	0.701	05.82	0.7887	-0.0980	0.0956	-0.7944	-0.0130	0.6219	0.0021	05.82	-00.01	0.0033	0.0026	0.0037	180.0	-0.0034
078	0.449	0.700	05.31	0.7500	-0.0873	0.0843	-0.7546	-0.0124	0.5624	0.0021	05.31	-00.01	0.0027	0.0025	0.0027	180.0	-0.0028
079	0.449	0.699	04.27	0.6935	-0.0766	0.0659	-0.6967	-0.0152	0.4269	0.0020	04.27	-00.01	0.0027	0.0023	0.0022	180.0	-0.0028
080	0.449	0.701	03.21	0.5372	-0.0744	0.0538	-0.5395	-0.0216	0.2884	0.0019	03.21	-00.02	0.0043	0.0033	0.0022	180.0	-0.0044
081	0.449	0.701	01.10	0.3100	-0.0685	0.0395	-0.3108	-0.0316	0.0960	0.0020	01.10	-00.01	0.0039	0.0026	0.0011	180.0	-0.0040
082	0.449	0.700	-01.01	0.0787	-0.0582	0.0342	-0.0781	-0.0338	0.0061	0.0018	-01.01	-00.01	0.0044	0.0025	0.0010	180.0	-0.0049
083	0.452	0.701	-03.12	-0.1505	-0.0463	0.0364	0.1522	-0.0265	0.0225	0.0017	-03.12	-00.01	0.0059	0.0028	0.0013	180.0	-0.0060
086	0.449	0.500	07.24	0.8094	-0.1106	0.1213	-0.8183	-0.0162	0.6550	0.0021	07.24	-00.01	0.0016	0.0029	0.0024	180.0	-0.0020
087	0.449	0.500	06.74	0.7879	-0.0986	0.1057	-0.7950	-0.0103	0.6208	0.0021	06.74	-00.01	0.0020	0.0028	0.0020	180.0	-0.0021

TABLE 2(8)
 CLEAR AIRCRAFT
 ETA = 0° ETRACT = +3 1/2°

SER	REYN.	KACH.	INCID.	LIFT.	PITCH.	DRAG	NORMAL	AXIAL.	CLSQ.	BASE.	RIHC.	SLIP.	CROSS.	YAW M.	ROLL M	RANG.	SIDE F
088	0.447	0.498	06.23	0.7494	-0.0883	0.0920	-0.7551	-0.0080	0.5615	0.0022	06.23	-(0.01	0.0015	0.0027	0.0018	180.0	-0.0016
089	0.450	0.500	05.72	0.7073	-0.0834	0.0810	-0.7120	-0.0079	0.5001	0.0022	05.72	-(0.01	0.0018	0.0027	0.0017	180.0	-0.0019
090	0.450	0.500	05.20	0.6620	-0.0798	0.0720	-0.6659	-0.0095	0.4381	0.0021	05.20	-(0.01	0.0022	0.0027	0.0019	180.0	-0.0023
091	0.450	0.499	04.17	0.5695	-0.0753	0.0580	-0.5723	-0.0143	0.3241	0.0021	04.17	-(0.01	0.0027	0.0027	0.0024	180.0	-0.0028
092	0.450	0.499	03.13	0.4734	-0.0712	0.0484	-0.4754	-0.0202	0.2239	0.0022	03.13	-(0.01	0.0034	0.0028	0.0020	180.0	-0.0035
093	0.450	0.500	01.06	0.2765	-0.0613	0.0370	-0.2772	-0.0299	0.0763	0.0020	01.06	-(0.01	0.0037	0.0025	0.0012	180.0	-0.0038
094	0.450	0.499	-01.01	0.0733	-0.0506	0.0332	-0.0728	-0.0327	0.0053	0.0019	-01.01	-(0.01	0.0046	0.0025	0.0013	180.0	-0.0047
095	0.447	0.498	-03.08	-0.1302	-0.0377	0.0394	0.1318	-0.0267	0.0168	0.0017	-03.08	-(0.01	0.0055	0.0026	0.0013	180.0	-0.0056

TABLE 3(A)
CLEAN AIRCRAFT
ETA = -15° ETRACT = +1/2°

SER	REVN.	MACH.	INC(D)	LIFT.	PITCH.	DRAG	NORMAL	AXIAL.	CLSR.	BASE.	MINC.	SLIP.	CROSS.	YAN M.	ROLL M	RANG.	SIDE F
002	0.457	0.899	06.53	0.7255	0.0719	0.1469	-0.7376	-0.0620	0.5263	0.0014	06.53	-00.03	-0.0380	-0.0007	-0.0017	179.9	0.0380
003	0.458	0.898	04.46	0.5676	0.1046	0.1070	-0.5744	-0.0612	0.3280	0.0012	04.46	-00.03	-0.0297	0.0004	0.0001	180.0	0.0296
004	0.458	0.898	02.37	0.3720	0.1345	0.0784	-0.3751	-0.0620	0.1383	0.0009	02.37	-00.02	-0.0179	0.0009	0.0019	180.0	0.0178
005	0.460	0.899	00.25	0.1292	0.1734	0.0643	-0.1296	-0.0632	0.0166	0.0005	00.25	-00.02	-0.0063	0.0014	0.0017	180.0	0.0062
006	0.453	0.880	06.53	0.7187	0.0849	0.1407	-0.7302	-0.0570	0.5165	0.0011	06.53	-00.03	-0.0373	-0.0002	-0.0016	179.9	0.0373
007	0.453	0.881	04.47	0.5648	0.1199	0.1024	-0.5712	-0.0570	0.3189	0.0011	04.47	-00.03	-0.0296	0.0002	0.0000	180.0	0.0295
008	0.453	0.880	02.38	0.3832	0.1501	0.0754	-0.3861	-0.0584	0.1467	0.0010	02.38	-00.03	-0.0180	0.0014	0.0018	180.0	0.0179
009	0.453	0.879	00.27	0.1480	0.1866	0.0604	-0.1484	-0.0593	0.0219	0.0005	00.27	-00.02	-0.0072	0.0015	0.0020	180.0	0.0072
012	0.462	0.863	06.54	0.7182	0.0953	0.1383	-0.7294	-0.0540	0.5158	0.0016	06.54	-00.03	-0.0377	-0.0003	-0.0007	179.9	0.0376
013	0.458	0.859	04.49	0.5767	0.1340	0.0976	-0.5826	-0.0511	0.3323	0.0011	04.49	-00.03	-0.0297	0.0004	0.0005	180.0	0.0297
014	0.458	0.858	02.41	0.3999	0.1692	0.0707	-0.4026	-0.0531	0.1598	0.0008	02.41	-00.02	-0.0193	0.0009	0.0021	180.0	0.0192
015	0.457	0.860	00.29	0.1489	0.2008	0.0565	-0.1493	-0.0554	0.0221	0.0004	00.29	-00.02	-0.0075	0.0018	0.0020	180.0	0.0074
016	0.450	0.840	06.53	0.7162	0.0995	0.1304	-0.7265	-0.0471	0.5129	0.0010	06.53	-00.03	-0.0361	0.0000	0.0003	180.0	0.0361
017	0.450	0.840	04.49	0.5872	0.1486	0.0937	-0.5928	-0.0465	0.3447	0.0010	04.49	-00.03	-0.0300	0.0005	0.0007	180.0	0.0299
018	0.450	0.840	02.42	0.4033	0.1846	0.0665	-0.4058	-0.0488	0.1625	0.0007	02.42	-00.03	-0.0204	0.0014	0.0024	180.0	0.0203
019	0.450	0.839	00.28	0.1345	0.2113	0.0542	-0.1349	-0.0530	0.0180	0.0006	00.28	-00.02	-0.0062	0.0017	0.0019	180.0	0.0061
022	0.467	0.801	06.54	0.7164	0.1190	0.1243	-0.7260	-0.0408	0.5131	0.0011	06.54	-00.03	-0.0360	0.0006	0.0016	180.0	0.0360
023	0.463	0.800	04.54	0.6115	0.1810	0.0867	-0.6166	-0.0370	0.3738	0.0011	04.54	-00.03	-0.0308	0.0009	0.0015	180.0	0.0307
024	0.463	0.800	02.42	0.3802	0.2076	0.0601	-0.3825	-0.0434	0.1444	0.0006	02.42	-00.03	-0.0187	0.0020	0.0023	180.0	0.0187
025	0.463	0.800	00.27	0.1194	0.2175	0.0518	-0.1157	-0.0509	0.0132	0.0004	00.27	-00.02	-0.0056	0.0022	0.0019	180.0	0.0055
026	0.445	0.751	06.52	0.7115	0.1493	0.1171	-0.7203	-0.0346	0.5062	0.0009	06.52	-00.03	-0.0343	0.0012	0.0033	180.0	0.0342
027	0.445	0.751	04.50	0.5879	0.2107	0.0774	-0.5922	-0.0299	0.3455	0.0010	04.50	-00.03	-0.0294	0.0016	0.0022	180.0	0.0294
028	0.447	0.752	02.37	0.3415	0.2140	0.0574	-0.3437	-0.0426	0.1165	0.0007	02.37	-00.02	-0.0160	0.0017	0.0022	180.0	0.0159
029	0.445	0.749	00.24	0.0988	0.2229	0.0484	-0.0991	-0.0477	0.0097	0.0004	00.24	-00.02	-0.0049	0.0019	0.0018	180.0	0.0048
030	0.426	0.702	06.48	0.6980	0.1719	0.1110	-0.7062	-0.0305	0.4871	0.0010	06.48	-00.03	-0.0322	0.0020	0.0038	180.0	0.0321
031	0.426	0.701	04.43	0.5354	0.2171	0.0717	-0.5394	-0.0291	0.2865	0.0009	04.43	-00.03	-0.0256	0.0019	0.0029	180.0	0.0255
032	0.422	0.700	02.32	0.3130	0.2206	0.0545	-0.3151	-0.0411	0.0979	0.0006	02.32	-00.02	-0.0156	0.0021	0.0022	180.0	0.0155
033	0.422	0.698	00.22	0.0826	0.2293	0.0483	-0.0829	-0.0478	0.0067	0.0003	00.22	-00.02	-0.0046	0.0020	0.0018	180.0	0.0045
036	0.440	0.499	06.35	0.6319	0.1887	0.0931	-0.6384	-0.0212	0.3992	0.0014	06.35	-00.03	-0.0309	0.0021	0.0021	180.0	0.0308
037	0.440	0.499	04.29	0.4497	0.2066	0.0619	-0.4532	-0.0272	0.2021	0.0009	04.29	-00.02	-0.0212	0.0022	0.0029	180.0	0.0211
038	0.440	0.500	02.23	0.2603	0.2194	0.0492	-0.2621	-0.0385	0.0677	0.0006	02.23	-00.02	-0.0123	0.0021	0.0024	180.0	0.0122
039	0.440	0.500	00.16	0.0586	0.2275	0.0458	-0.0589	-0.0452	0.0033	0.0005	00.16	-00.01	-0.0032	0.0021	0.0021	180.0	0.0031

TABLE 3(B)
 CLEAN AIRCRAFT
 ETR = -10° ETRCT = +1.2°

SER	REVW	HIGH	INC.D.	LIFT.	PITCH.	DRAW	NORMAL	AXIAL.	CLSQ.	BASE.	AINC.	SLIP.	CROSS.	YAW M.	ROLL M	RANG.	SIDE F
002	0.457	0.901	06.47	0.7564	-0.0067	0.1438	-0.7679	-0.0559	0.5224	0.0018	06.47	00.00	-0.0051	-0.0015	-0.0012	179.9	0.0050
003	0.457	0.900	04.40	0.5935	0.0341	0.1033	-0.5997	-0.0557	0.3521	0.0017	04.40	00.00	-0.0035	-0.0012	0.0004	180.0	0.0034
004	0.457	0.899	02.31	0.3929	0.0630	0.0735	-0.3956	-0.0562	0.1543	0.0014	02.31	00.00	-0.0013	-0.0005	0.0016	180.0	0.0012
005	0.457	0.900	00.18	0.1435	0.0972	0.0584	-0.1437	-0.0567	0.0205	0.0012	00.18	00.00	0.0000	-0.0004	0.0015	180.0	-0.0001
006	0.450	0.879	06.46	0.7485	0.0059	0.1371	-0.7593	-0.0504	0.5602	0.0016	06.46	00.00	-0.0049	-0.0015	-0.0010	179.9	0.0048
007	0.450	0.879	04.41	0.5905	0.0528	0.0969	-0.5963	-0.0498	0.3486	0.0014	04.41	00.00	-0.0037	-0.0013	0.0001	180.0	0.0036
008	0.450	0.879	02.32	0.4054	0.0803	0.0696	-0.4080	-0.0518	0.1643	0.0013	02.32	00.00	-0.0012	-0.0004	0.0016	180.0	0.0011
009	0.450	0.879	00.21	0.1707	0.1117	0.0531	-0.1710	-0.0514	0.0290	0.0011	00.21	00.00	-0.0010	-0.0006	0.0017	180.0	0.0009
012	0.460	0.860	06.48	0.7528	0.0159	0.1338	-0.7632	-0.0464	0.5666	0.0016	06.48	00.00	-0.0048	-0.0015	-0.0005	179.9	0.0047
013	0.460	0.858	04.43	0.6012	0.0645	0.0917	-0.6066	-0.0435	0.3614	0.0014	04.43	00.00	-0.0035	-0.0013	0.0005	180.0	0.0034
014	0.463	0.860	02.35	0.4214	0.0958	0.0655	-0.4238	-0.0468	0.1774	0.0013	02.35	00.00	-0.0011	-0.0005	0.0018	180.0	0.0010
015	0.463	0.860	00.23	0.1729	0.1268	0.0485	-0.1728	-0.0468	0.0296	0.0011	00.23	00.00	-0.0003	-0.0003	0.0018	180.0	0.0002
016	0.453	0.839	06.49	0.7361	0.0504	0.1241	-0.7455	-0.0387	0.5418	0.0014	06.49	00.00	-0.0056	-0.0016	0.0007	180.0	0.0055
017	0.457	0.840	04.44	0.6121	0.0755	0.0890	-0.6173	-0.0399	0.3746	0.0013	04.44	00.00	-0.0036	-0.0008	0.0007	180.0	0.0035
018	0.455	0.841	02.36	0.4289	0.1101	0.0619	-0.4312	-0.0429	0.1838	0.0012	02.36	00.00	-0.0020	-0.0004	0.0020	180.0	0.0019
019	0.455	0.840	00.23	0.1621	0.1369	0.0461	-0.1623	-0.0444	0.0262	0.0011	00.23	00.01	0.0000	0.0002	0.0017	180.0	-0.0001
022	0.471	0.801	06.48	0.7517	0.0311	0.1203	-0.7605	-0.0334	0.5650	0.0013	06.48	00.00	-0.0030	-0.0010	0.0020	180.0	0.0029
023	0.470	0.800	04.48	0.6416	0.1027	0.0826	-0.6462	-0.0308	0.4315	0.0014	04.48	00.00	-0.0037	-0.0009	0.0013	180.0	0.0036
024	0.470	0.800	02.37	0.4102	0.1327	0.0544	-0.4122	-0.0363	0.1681	0.0010	02.37	00.00	-0.0016	-0.0002	0.0021	180.0	0.0015
025	0.470	0.801	00.22	0.1415	0.1413	0.0432	-0.1418	-0.0418	0.0199	0.0009	00.22	00.00	0.0000	-0.0003	0.0017	180.0	-0.0001
026	0.449	0.750	06.46	0.7486	0.0600	0.1126	-0.7566	-0.0264	0.5603	0.0012	06.46	00.00	-0.0018	-0.0003	0.0036	180.0	0.0017
027	0.449	0.750	04.45	0.6223	0.1271	0.0716	-0.6261	-0.0218	0.3872	0.0014	04.45	00.01	-0.0030	-0.0002	0.0021	180.0	0.0030
028	0.450	0.752	02.32	0.3735	0.1324	0.0488	-0.3753	-0.0325	0.1394	0.0011	02.32	00.00	-0.0008	-0.0002	0.0021	180.0	0.0007
029	0.449	0.750	00.19	0.1270	0.1403	0.0415	-0.1272	-0.0403	0.0160	0.0008	00.19	00.00	-0.0007	-0.0002	0.0016	180.0	0.0005
030	0.426	0.699	06.43	0.7383	0.0798	0.1061	-0.7456	-0.0214	0.5450	0.0014	06.43	00.00	-0.0004	0.0003	0.0042	186.9	0.0003
031	0.429	0.700	04.38	0.5759	0.1217	0.0658	-0.5794	-0.0204	0.3315	0.0012	04.38	00.00	-0.0014	-0.0001	0.0029	180.0	0.0013
032	0.427	0.701	02.27	0.3494	0.1289	0.0477	-0.3511	-0.0328	0.1220	0.0011	02.27	00.01	-0.0011	-0.0001	0.0021	180.0	0.0010
033	0.429	0.701	00.16	0.1176	0.1385	0.0409	-0.1178	-0.0398	0.0137	0.0008	00.16	00.00	-0.0004	-0.0002	0.0016	180.0	0.0003
036	0.449	0.501	06.31	0.6737	0.0950	0.0898	-0.6796	-0.0136	0.4577	0.0016	06.31	00.01	-0.0028	0.0003	0.0024	180.0	0.0027
037	0.449	0.501	04.25	0.4920	0.1112	0.0581	-0.4950	-0.0199	0.2418	0.0015	04.25	00.01	-0.0016	0.0002	0.0028	180.0	0.0015
038	0.450	0.500	02.18	0.2986	0.1201	0.0437	-0.3001	-0.0312	0.0890	0.0011	02.18	00.01	-0.0004	0.0002	0.0022	180.0	0.0003
039	0.450	0.500	00.11	0.0957	0.1320	0.0390	-0.0958	-0.0378	0.0090	0.0010	00.11	00.01	0.0003	0.0001	0.0020	180.0	-0.0004

TABLE 3(C)
 CLEAN AIRCRAFT
 ETR = -5° ETRCT = +1/2°

SER	REVW.	WICH.	INC/D.	LIFT.	PITCH.	DRAW	NORMAL	AXIAL.	CLSQ.	BASE.	RIIC.	SLIP.	CROSS.	YAN M.	ROLL M	RANG.	SIDE F
002	0.452	0.903	06.42	0.7779	-0.0733	0.1418	-0.7890	-0.0518	0.6051	0.0022	06.42	00.00	-0.0050	-0.0016	-0.0011	179.9	0.0049
003	0.449	0.900	04.34	0.6178	-0.0397	0.1009	-0.6238	-0.0518	0.3816	0.0020	04.34	00.00	-0.0035	-0.0006	0.0005	180.0	0.0034
004	0.449	0.900	02.24	0.4178	-0.0133	0.0691	-0.4203	-0.0508	0.1744	0.0019	02.24	00.00	-0.0019	-0.0004	0.0016	180.0	0.0018
005	0.452	0.901	00.12	0.1673	0.0146	0.0532	-0.1675	-0.0510	0.0279	0.0018	00.12	00.00	-0.0002	-0.0004	0.0014	180.0	0.0001
006	0.445	0.891	06.42	0.7709	-0.0392	0.1348	-0.7813	-0.0458	0.5943	0.0020	06.42	00.00	-0.0053	-0.0014	-0.0008	179.9	0.0052
007	0.445	0.891	04.35	0.6143	-0.0224	0.0940	-0.6198	-0.0452	0.3773	0.0019	04.35	00.00	-0.0040	-0.0009	0.0002	180.0	0.0039
008	0.445	0.892	02.26	0.4290	-0.0003	0.0660	-0.4313	-0.0471	0.1839	0.0019	02.26	00.00	-0.0005	-0.0003	0.0016	180.0	0.0004
009	0.445	0.890	00.14	0.1940	0.0288	0.0485	-0.1940	-0.0465	0.0375	0.0016	00.14	00.00	-0.0005	-0.0004	0.0014	180.0	0.0004
012	0.455	0.911	06.43	0.7756	-0.0479	0.1321	-0.7857	-0.0425	0.6016	0.0019	06.43	00.00	-0.0050	-0.0013	-0.0004	179.9	0.0049
013	0.452	0.900	04.37	0.6250	-0.0094	0.0893	-0.6301	-0.0396	0.3906	0.0018	04.37	00.00	-0.0037	-0.0008	0.0004	180.0	0.0036
014	0.455	0.911	02.29	0.4469	0.0166	0.0620	-0.4492	-0.0424	0.1995	0.0017	02.29	00.00	-0.0024	-0.0008	0.0018	180.0	0.0023
015	0.452	0.902	00.16	0.1974	0.0437	0.0445	-0.1976	-0.0424	0.0388	0.0015	00.16	00.00	-0.0003	-0.0001	0.0017	180.0	0.0002
016	0.445	0.890	06.45	0.7590	-0.0080	0.1263	-0.7685	-0.0384	0.5760	0.0018	06.45	00.00	-0.0047	-0.0014	-0.0003	179.9	0.0046
017	0.445	0.890	04.38	0.6388	0.0034	0.0864	-0.6437	-0.0354	0.4080	0.0018	04.38	00.00	-0.0037	-0.0010	0.0006	180.0	0.0036
018	0.447	0.891	02.30	0.4544	0.0323	0.0593	-0.4566	-0.0394	0.2064	0.0016	02.30	-00.01	-0.0010	0.0002	0.0020	180.0	0.0009
019	0.447	0.891	00.16	0.1858	0.0368	0.0412	-0.1861	-0.0392	0.0345	0.0015	00.16	00.00	-0.0009	-0.0002	0.0016	180.0	0.0008
022	0.462	0.912	06.44	0.7705	-0.0182	0.1190	-0.7791	-0.0302	0.5936	0.0016	06.44	00.00	-0.0035	-0.0010	0.0022	180.0	0.0034
023	0.462	0.909	04.42	0.6672	0.0296	0.0801	-0.6715	-0.0266	0.4450	0.0018	04.42	00.00	-0.0028	-0.0006	0.0015	180.0	0.0027
024	0.462	0.900	02.31	0.4343	0.0350	0.0501	-0.4361	-0.0311	0.1885	0.0015	02.31	00.00	-0.0014	-0.0002	0.0020	180.0	0.0013
025	0.462	0.900	00.16	0.1678	0.0628	0.0397	-0.1680	-0.0380	0.0280	0.0013	00.16	-00.01	-0.0006	-0.0001	0.0017	180.0	0.0005
026	0.442	0.752	06.42	0.7688	-0.0005	0.1108	-0.7764	-0.0226	0.5909	0.0015	06.42	00.00	-0.0006	0.0000	0.0043	180.0	0.0005
027	0.440	0.750	04.40	0.6460	0.0332	0.0691	-0.6495	-0.0178	0.4372	0.0016	04.40	00.00	-0.0026	-0.0004	0.0021	180.0	0.0023
028	0.440	0.750	02.26	0.3970	0.0570	0.0469	-0.3987	-0.0298	0.1575	0.0014	02.26	00.00	-0.0010	-0.0002	0.0020	180.0	0.0009
029	0.442	0.750	00.14	0.1540	0.0638	0.0388	-0.1542	-0.0370	0.0236	0.0015	00.14	00.00	-0.0004	-0.0001	0.0016	180.0	0.0003
030	0.419	0.700	06.38	0.7592	0.0136	0.1093	-0.7664	-0.0184	0.5764	0.0018	06.38	00.00	-0.0011	0.0002	0.0044	180.0	0.0010
031	0.419	0.701	04.33	0.5977	0.0322	0.0637	-0.6010	-0.0167	0.3572	0.0016	04.33	-00.01	-0.0020	0.0000	0.0027	180.0	0.0019
032	0.422	0.699	02.22	0.3719	0.0352	0.0449	-0.3735	-0.0289	0.1383	0.0015	02.22	-00.01	-0.0008	0.0000	0.0019	180.0	0.0007
033	0.419	0.700	00.12	0.1431	0.0637	0.0377	-0.1433	-0.0361	0.0204	0.0014	00.12	00.00	-0.0009	-0.0002	0.0016	180.0	0.0008
036	0.437	0.500	06.28	0.6992	0.0311	0.0892	-0.7049	-0.0102	0.4888	0.0019	06.28	-00.01	-0.0025	0.0002	0.0022	180.0	0.0024
037	0.437	0.499	04.22	0.5162	0.0447	0.0564	-0.5191	-0.0165	0.2663	0.0017	04.22	-00.01	-0.0009	0.0002	0.0028	180.0	0.0008
038	0.437	0.500	02.15	0.3264	0.0322	0.0416	-0.3278	-0.0277	0.1064	0.0016	02.15	-00.01	-0.0006	0.0001	0.0021	180.0	0.0005
039	0.437	0.499	00.08	0.1237	0.0626	0.0362	-0.1239	-0.0345	0.0132	0.0015	00.08	00.00	0.0004	0.0000	0.0018	180.0	-0.0009

TABLE 3(D)
CLEAN AIRCRAFT
ETA = 0°E(TACT) = +1/2°

SER	REYN.	MACH.	MKC/D	LIFT.	PITCH.	DRAW	NORMAL	AXIAL.	CLSD.	BASE.	RIHC.	SLIP.	CROSS.	YAN M.	ROLL M	RANG.	SIDE F
002	0.447	0.890	07.42	0.8615	-0.1186	0.1684	-0.8762	-0.0536	0.7421	0.0021	07.42	(0.01	-0.0033	-0.0005	-0.0002	179.9	0.0032
003	0.449	0.900	06.90	0.8304	-0.1193	0.1560	-0.8432	-0.0528	0.6894	0.0023	06.90	(0.00	-0.0034	-0.0009	-0.0003	179.9	0.0033
004	0.449	0.901	06.37	0.7936	-0.1237	0.1429	-0.8047	-0.0518	0.6298	0.0022	06.37	(0.00	-0.0039	-0.0011	-0.0010	179.9	0.0038
005	0.449	0.901	05.85	0.7549	-0.1221	0.1298	-0.7643	-0.0500	0.5699	0.0022	05.85	(0.00	-0.0042	-0.0011	-0.0005	179.9	0.0041
006	0.450	0.899	05.33	0.7208	-0.1181	0.1195	-0.7289	-0.0498	0.5195	0.0023	05.33	(0.00	-0.0043	-0.0015	-0.0006	179.9	0.0042
007	0.450	0.899	04.29	0.6402	-0.1081	0.0995	-0.6460	-0.0492	0.4098	0.0021	04.29	(0.00	-0.0040	-0.0010	0.0004	180.0	0.0038
008	0.447	0.900	03.24	0.5453	-0.0991	0.0831	-0.5492	-0.0501	0.2972	0.0021	03.24	(0.00	-0.0026	-0.0010	0.0011	180.0	0.0025
009	0.449	0.901	01.12	0.3184	-0.0756	0.0583	-0.3196	-0.0502	0.1013	0.0019	01.12	(0.00	-0.0017	-0.0004	0.0015	180.0	0.0016
010	0.447	0.900	-01.01	0.0495	-0.0372	0.0474	-0.0488	-0.0466	0.0024	0.0017	-01.01	(0.00	0.0004	-0.0001	0.0017	180.0	-0.0003
011	0.449	0.900	-03.15	-0.2530	0.0154	0.0576	0.2557	-0.0421	0.0639	0.0016	-03.15	(0.00	0.0015	0.0000	0.0020	180.0	-0.0016
014	0.453	0.879	07.44	0.8354	-0.0773	0.1599	-0.8492	-0.0484	0.6977	0.0019	07.44	(0.00	-0.0055	-0.0011	0.0008	180.0	0.0054
015	0.450	0.880	06.90	0.8232	-0.1143	0.1485	-0.8352	-0.0464	0.6775	0.0021	06.90	(0.01	-0.0034	-0.0003	-0.0002	179.9	0.0033
016	0.452	0.878	06.38	0.7896	-0.1135	0.1348	-0.7998	-0.0443	0.6233	0.0020	06.38	(0.00	-0.0050	-0.0014	-0.0008	179.9	0.0049
017	0.450	0.881	05.86	0.7529	-0.1100	0.1233	-0.7617	-0.0437	0.5668	0.0021	05.86	(0.00	-0.0041	-0.0013	-0.0004	179.9	0.0040
018	0.450	0.881	05.34	0.7147	-0.1056	0.1120	-0.7221	-0.0429	0.5107	0.0021	05.34	(0.00	-0.0043	-0.0013	-0.0001	179.9	0.0042
019	0.450	0.879	04.31	0.6402	-0.0893	0.0932	-0.6455	-0.0429	0.4098	0.0020	04.31	(0.00	-0.0032	-0.0011	0.0002	180.0	0.0031
020	0.450	0.879	03.26	0.5509	-0.0780	0.0767	-0.5545	-0.0434	0.3033	0.0018	03.26	(0.00	-0.0023	-0.0009	0.0013	180.0	0.0022
021	0.450	0.880	01.15	0.3405	-0.0584	0.0559	-0.3416	-0.0474	0.1158	0.0017	01.15	(0.00	-0.0018	-0.0006	0.0016	180.0	0.0017
022	0.450	0.880	-00.99	0.0735	-0.0290	0.0416	-0.0729	-0.0413	0.0053	0.0016	-00.99	(0.00	-0.0006	-0.0002	0.0018	180.0	0.0005
023	0.450	0.879	-03.15	-0.2468	0.0114	0.0500	0.2491	-0.0350	0.0608	0.0015	-03.15	(0.00	0.0028	0.0003	0.0017	180.0	-0.0030
026	0.452	0.861	07.41	0.8268	-0.1075	0.1538	-0.8398	-0.0439	0.6835	0.0020	07.41	(0.00	-0.0037	-0.0012	0.0034	180.0	0.0036
027	0.449	0.860	06.91	0.8127	-0.0919	0.1418	-0.8240	-0.0411	0.6604	0.0019	06.91	(0.00	-0.0058	-0.0014	0.0003	180.0	0.0057
028	0.452	0.861	06.39	0.7942	-0.1060	0.1315	-0.8040	-0.0403	0.6307	0.0020	06.39	(0.00	-0.0046	-0.0014	-0.0005	179.9	0.0045
029	0.452	0.862	05.87	0.7608	-0.1012	0.1200	-0.7692	-0.0395	0.5787	0.0020	05.87	(0.00	-0.0045	-0.0014	-0.0002	179.9	0.0044
030	0.452	0.860	05.35	0.7236	-0.0918	0.1089	-0.7308	-0.0389	0.5236	0.0020	05.35	(0.00	-0.0040	-0.0014	0.0002	180.0	0.0039
031	0.450	0.859	04.32	0.6498	-0.0743	0.0878	-0.6547	-0.0367	0.4221	0.0019	04.32	(0.00	-0.0040	-0.0011	0.0004	180.0	0.0039
032	0.452	0.860	03.28	0.5616	-0.0630	0.0743	-0.5650	-0.0401	0.3152	0.0020	03.28	(0.00	-0.0024	-0.0009	0.0013	180.0	0.0023
033	0.452	0.860	01.17	0.3533	-0.0426	0.0511	-0.3544	-0.0423	0.1247	0.0015	01.17	(0.01	-0.0002	-0.0002	0.0017	180.0	0.0001
034	0.452	0.860	-00.98	0.0727	-0.0162	0.0386	-0.0721	-0.0382	0.0052	0.0016	-00.98	(0.01	-0.0001	0.0000	0.0018	180.0	0.0000
035	0.450	0.859	-03.14	-0.2334	0.0065	0.0434	0.2384	-0.0312	0.0543	0.0014	-03.14	(0.00	0.0019	0.0001	0.0019	180.0	-0.0020
038	0.449	0.840	07.39	0.8197	-0.1079	0.1478	-0.8320	-0.0393	0.6718	0.0018	07.39	(0.00	-0.0024	-0.0007	0.0031	180.0	0.0022
039	0.445	0.840	06.89	0.8044	-0.0964	0.1376	-0.8152	-0.0382	0.6468	0.0018	06.89	(0.00	-0.0035	-0.0010	0.0020	180.0	0.0034
040	0.445	0.840	06.39	0.7920	-0.0899	0.1267	-0.8013	-0.0359	0.6272	0.0018	06.39	(0.00	-0.0042	-0.0010	0.0009	180.0	0.0041
041	0.445	0.840	05.88	0.7722	-0.0889	0.1163	-0.7802	-0.0346	0.5962	0.0019	05.88	(0.00	-0.0047	-0.0014	-0.0002	179.9	0.0046
042	0.447	0.841	05.37	0.7361	-0.0816	0.1055	-0.7429	-0.0343	0.5419	0.0019	05.37	(0.00	-0.0037	-0.0012	0.0004	180.0	0.0036
043	0.447	0.840	04.34	0.6606	-0.0623	0.0897	-0.6653	-0.0336	0.4362	0.0019	04.34	(0.00	-0.0036	-0.0012	0.0007	180.0	0.0035

TABLE 3(D)
CLEAN AIRCRAFT
ETA = 0° ETRACT = +1/2°

SER	REVN.	HACH.	INC'D.	LIFT.	PITCH.	DRAW	NORMAL	AXIAL.	CLSD.	BASE.	RIHC.	SLIP.	CROSS.	YAW M.	ROLL M	RANG.	SIDE F
044	0.449	0.840	03.30	0.5768	-0.0487	0.0711	-0.5801	-0.0360	0.7326	0.0048	03.30	00.00	-0.0022	-0.0010	0.0015	180.0	0.0021
045	0.445	0.839	01.18	0.3475	-0.0253	0.0468	-0.3485	-0.0381	0.1206	0.0045	01.18	00.00	-0.0013	-0.0002	0.0018	180.0	0.0012
046	0.447	0.841	-00.97	0.0667	-0.0092	0.0380	-0.0661	-0.0377	0.0044	0.0045	-00.97	00.00	-0.0004	-0.0000	0.0017	180.0	0.0003
047	0.449	0.839	-03.14	-0.2211	0.0041	0.0431	0.2231	-0.0297	0.0488	0.0013	-03.14	00.00	0.0019	0.0000	0.0020	180.0	-0.0020
048	0.447	0.841	07.40	0.8197	-0.1083	0.1476	-0.8320	-0.0389	0.6719	0.0020	07.40	00.00	-0.0032	-0.0010	0.0026	180.0	0.0031
051	0.444	0.801	07.39	0.8195	-0.0996	0.1416	-0.8311	-0.0334	0.6715	0.0017	07.39	00.00	-0.0020	-0.0007	0.0025	180.0	0.0019
052	0.445	0.799	06.88	0.8087	-0.0926	0.1299	-0.8186	-0.0302	0.6539	0.0018	06.88	00.00	-0.0033	-0.0007	0.0029	180.0	0.0032
053	0.442	0.798	06.38	0.7953	-0.0852	0.1199	-0.8038	-0.0290	0.6324	0.0017	06.38	00.00	-0.0034	-0.0005	0.0031	180.0	0.0033
054	0.445	0.800	05.90	0.7694	-0.0496	0.1085	-0.7766	-0.0270	0.5920	0.0018	05.90	00.00	-0.0034	-0.0010	0.0018	180.0	0.0033
055	0.445	0.800	05.34	0.7604	-0.0579	0.0986	-0.7664	-0.0251	0.5782	0.0017	05.34	00.00	-0.0043	-0.0012	0.0006	180.0	0.0042
056	0.444	0.801	04.36	0.6880	-0.0359	0.0793	-0.6922	-0.0249	0.4733	0.0018	04.36	00.00	-0.0023	-0.0008	0.0012	180.0	0.0022
057	0.444	0.801	03.32	0.5846	-0.0212	0.0615	-0.5873	-0.0258	0.3417	0.0017	03.32	00.00	-0.0016	-0.0004	0.0023	180.0	0.0015
058	0.444	0.801	01.17	0.3203	-0.0108	0.0418	-0.3211	-0.0338	0.1025	0.0015	01.17	00.00	-0.0011	-0.0006	0.0017	180.0	0.0010
059	0.445	0.799	-00.97	0.0591	-0.0026	0.0373	-0.0586	-0.0370	0.0034	0.0013	-00.97	00.00	-0.0001	-0.0002	0.0016	180.0	0.0000
060	0.445	0.800	-03.12	-0.2018	0.0071	0.0403	0.2036	-0.0281	0.0406	0.0012	-03.12	00.00	0.0009	-0.0002	0.0019	180.0	-0.0010
063	0.442	0.750	07.39	0.8222	-0.0756	0.1357	-0.8330	-0.0272	0.6759	0.0016	07.39	00.00	-0.0016	-0.0003	0.0048	180.0	0.0015
064	0.442	0.750	06.89	0.7967	-0.0502	0.1242	-0.8056	-0.0232	0.6346	0.0015	06.89	00.00	-0.0006	-0.0004	0.0051	180.0	0.0005
065	0.440	0.749	06.38	0.7944	-0.0631	0.1122	-0.8020	-0.0214	0.6310	0.0017	06.38	00.00	-0.0018	-0.0004	0.0046	180.0	0.0017
066	0.442	0.750	05.88	0.7730	-0.0487	0.1008	-0.7794	-0.0193	0.5974	0.0017	05.88	00.00	-0.0011	-0.0004	0.0043	180.0	0.0010
067	0.442	0.749	05.38	0.7504	-0.0321	0.0888	-0.7555	-0.0163	0.5630	0.0017	05.38	00.00	-0.0015	-0.0005	0.0028	180.0	0.0014
068	0.442	0.749	04.35	0.6671	-0.0113	0.0691	-0.6705	-0.0166	0.4449	0.0017	04.35	00.00	-0.0022	-0.0006	0.0022	180.0	0.0021
069	0.442	0.749	03.29	0.5430	-0.0089	0.0545	-0.5454	-0.0221	0.2947	0.0016	03.29	00.00	-0.0014	-0.0004	0.0023	180.0	0.0013
070	0.442	0.750	01.15	0.2952	-0.0078	0.0411	-0.2961	-0.0338	0.0871	0.0014	01.15	-00.01	-0.0007	0.0000	0.0017	180.0	0.0006
071	0.442	0.750	-00.97	0.0548	0.0006	0.0354	-0.0543	-0.0351	0.0029	0.0012	-00.97	00.00	-0.0011	-0.0005	0.0017	180.0	0.0010
072	0.442	0.749	-03.10	-0.1873	0.0120	0.0385	0.1890	-0.0272	0.0350	0.0012	-03.10	00.00	0.0008	-0.0002	0.0020	180.0	-0.0009
076	0.440	0.699	07.36	0.8147	-0.0742	0.1299	-0.8248	-0.0228	0.6637	0.0016	07.36	00.00	-0.0029	-0.0003	0.0036	180.0	0.0028
077	0.442	0.701	06.88	0.7972	-0.0446	0.1157	-0.8054	-0.0177	0.6354	0.0018	06.88	00.00	-0.0021	0.0001	0.0045	180.0	0.0020
078	0.442	0.701	06.37	0.7821	-0.0458	0.1090	-0.7891	-0.0158	0.6117	0.0018	06.37	00.00	-0.0013	0.0002	0.50	180.0	0.0012
079	0.442	0.702	05.86	0.7570	-0.0330	0.0930	-0.7627	-0.0133	0.5730	0.0018	05.86	00.00	-0.0017	-0.0001	0.0042	180.0	0.0016
080	0.440	0.699	05.35	0.7193	-0.0217	0.0812	-0.7238	-0.0119	0.5173	0.0018	05.35	00.00	-0.0016	0.0000	0.0032	180.0	0.0015
081	0.442	0.701	04.31	0.6234	-0.0111	0.0640	-0.6265	-0.0153	0.3885	0.0017	04.31	00.00	-0.0020	-0.0002	0.0029	180.0	0.0019
082	0.442	0.700	03.25	0.5095	-0.0102	0.0518	-0.5118	-0.0211	0.2595	0.0017	03.25	00.00	-0.0019	-0.0006	0.0028	180.0	0.0018
083	0.442	0.700	01.14	0.2796	-0.0067	0.0391	-0.2805	-0.0321	0.0781	0.0018	01.14	00.00	-0.0012	-0.0004	0.0017	180.0	0.0011
084	0.442	0.700	-00.98	0.0500	0.0024	0.0355	-0.0495	-0.0351	0.0024	0.0013	-00.98	00.00	0.0000	-0.0003	0.0017	180.0	-0.0001
085	0.442	0.700	-03.09	-0.1782	0.0150	0.0383	0.1799	-0.0275	0.0316	0.0012	-03.09	00.00	0.0008	-0.0002	0.0020	180.0	-0.0009
086	0.437	0.501	07.27	0.7803	-0.0525	0.1167	-0.7889	-0.0149	0.6088	0.0021	07.27	-00.01	-0.0027	0.0002	0.0027	180.0	0.0026

TABLE 3(D)
 CLEAN AIRCRAFT
 $\text{ETA} = 0^\circ \text{TRACT} = +1/2^\circ$

SER	REYN.	MACH.	INCID.	LIFT.	PITCH.	DRAG	NORMAL	AXIAL.	CLSQ.	BASE.	RIHC.	SLIP.	CROSS.	YAW M.	ROLL M	RANG.	SIDE F
089	0.437	0.501	06.76	0.7534	-0.0370	0.1016	-0.7602	-0.0102	0.5676	0.0020	06.76	-(0.01	-0.0027	0.0002	0.0023	180.0	0.0026
090	0.437	0.501	06.26	0.7178	-0.0270	0.0893	-0.7234	-0.0085	0.5153	0.0020	06.26	-(0.01	-0.0026	0.0003	0.0024	180.0	0.0025
091	0.437	0.501	05.74	0.6725	-0.0221	0.0784	-0.6770	-0.0087	0.4521	0.0020	05.74	-(0.01	-0.0027	0.0001	0.0023	180.0	0.0026
092	0.434	0.500	05.23	0.6305	-0.0188	0.0697	-0.6344	-0.0099	0.3974	0.0021	05.23	-(0.01	-0.0020	0.0001	0.0024	180.0	0.0019
093	0.437	0.500	04.19	0.5358	-0.0149	0.0560	-0.5386	-0.0149	0.2869	0.0018	04.19	-(0.01	-0.0015	0.0000	0.0028	180.0	0.0014
094	0.437	0.502	03.16	0.4420	-0.0117	0.0472	-0.4440	-0.0209	0.1952	0.0018	03.16	-(0.01	-0.0011	0.0000	0.0026	180.0	0.0011
095	0.437	0.502	01.09	0.2464	-0.0045	0.0371	-0.2472	-0.0308	0.0606	0.0017	01.09	(0.00	-0.0007	-0.0002	0.0019	180.0	0.0006
096	0.437	0.500	-00.98	0.0443	0.0058	0.0331	-0.0438	-0.0324	0.0018	0.0015	-00.98	-(0.01	0.0000	0.0000	0.0019	180.0	-0.0001
097	0.437	0.500	-03.05	-0.1577	0.0187	0.0368	0.1593	-0.0270	0.0248	0.0014	-03.05	(0.00	0.0006	-0.0002	0.0022	180.0	-0.0007

TABLE 3(E)
 CLEAN AIRCRAFT
 ETR = +5° ETRACT) = +1/2°

SER	REVN.	MACH.	INC/D.	LIFT.	PITCH.	DRAG	NORMAL	AXIAL.	CL SQ.	BASE.	PLND.	SLIP.	CROSS.	YAW M.	ROLL M	RANG.	SIDE F
002	0.447	0.902	06.36	0.7897	-0.1371	0.1407	-0.8005	-0.0498	0.6236	0.0026	06.36	-(0.01	0.0007	0.0012	-0.0010	179.9	-0.0007
003	0.444	0.899	04.25	0.6548	-0.1605	0.0986	-0.6604	-0.0475	0.4286	0.0024	04.25	-(0.01	0.0021	0.0018	0.0002	180.0	-0.0022
004	0.447	0.902	02.13	0.4622	-0.1594	0.0713	-0.4647	-0.0518	0.2135	0.0023	02.13	-(0.01	0.0037	0.0023	0.0011	180.0	-0.0038
005	0.447	0.901	00.00	0.2148	-0.1299	0.0512	-0.2149	-0.0490	0.0460	0.0022	00.00	-(0.02	0.0043	0.0025	0.0008	180.0	-0.0044
006	0.440	0.880	06.35	0.7927	-0.1417	0.1350	-0.8029	-0.0442	0.6282	0.0023	06.35	-(0.01	0.0014	0.0015	-0.0003	179.9	-0.0015
007	0.442	0.882	04.25	0.6599	-0.1550	0.0949	-0.6652	-0.0435	0.4353	0.0022	04.25	-(0.01	0.0018	0.0018	-0.0002	179.9	-0.0019
008	0.440	0.881	02.16	0.4774	-0.1364	0.0649	-0.4796	-0.0448	0.2278	0.0021	02.16	-(0.02	0.0048	0.0025	0.0010	180.0	-0.0049
009	0.440	0.880	00.03	0.2396	-0.1115	0.0459	-0.2398	-0.0438	0.0573	0.0020	00.03	-(0.02	0.0043	0.0025	0.0009	180.0	-0.0044
012	0.440	0.860	06.35	0.8035	-0.1382	0.1317	-0.8133	-0.0397	0.6455	0.0023	06.35	-(0.01	0.0003	0.0012	-0.0007	179.9	-0.0004
013	0.440	0.860	04.27	0.6745	-0.1431	0.0886	-0.6793	-0.0361	0.4549	0.0020	04.27	-(0.01	0.0015	0.0015	0.0000	180.0	-0.0015
014	0.440	0.861	02.18	0.4937	-0.1201	0.0602	-0.4958	-0.0395	0.2436	0.0019	02.18	-(0.01	0.0041	0.0020	0.0012	180.0	-0.0042
015	0.439	0.858	00.05	0.2392	-0.0916	0.0425	-0.2393	-0.0405	0.0571	0.0018	00.05	-(0.02	0.0053	0.0026	0.0011	180.0	-0.0054
016	0.434	0.840	06.35	0.8084	-0.1388	0.1267	-0.8176	-0.0346	0.6534	0.0019	06.35	-(0.01	-0.0002	0.0012	-0.0004	179.9	0.0001
017	0.434	0.840	04.28	0.6866	-0.1304	0.0866	-0.6912	-0.0331	0.4713	0.0020	04.28	-(0.01	0.0011	0.0012	0.0001	180.0	-0.0012
018	0.434	0.840	02.19	0.4978	-0.1010	0.0565	-0.4997	-0.0354	0.2477	0.0020	02.19	-(0.01	0.0033	0.0023	0.0013	180.0	-0.0034
019	0.434	0.839	00.05	0.2261	-0.0793	0.0408	-0.2262	-0.0388	0.0510	0.0018	00.05	-(0.02	0.0044	0.0026	0.0009	180.0	-0.0045
022	0.455	0.800	06.37	0.8019	-0.1079	0.1201	-0.8104	-0.0284	0.6429	0.0019	06.37	-(0.01	0.0039	0.0024	0.0029	180.0	-0.0040
023	0.455	0.799	04.33	0.7153	-0.1013	0.0797	-0.7193	-0.0235	0.5116	0.0019	04.33	-(0.01	0.0007	0.0017	0.0009	180.0	-0.0007
024	0.455	0.801	02.20	0.4753	-0.0788	0.0496	-0.4770	-0.0294	0.2298	0.0019	02.20	-(0.01	0.0033	0.0021	0.0013	180.0	-0.0034
025	0.455	0.801	00.05	0.2114	-0.0718	0.0380	-0.2116	-0.0361	0.0446	0.0018	00.05	-(0.02	0.0044	0.0025	0.0010	180.0	-0.0045
026	0.437	0.750	06.34	0.8117	-0.1170	0.1122	-0.8192	-0.0200	0.6587	0.0018	06.34	-(0.01	0.0045	0.0025	0.0046	180.0	-0.0046
027	0.437	0.749	04.30	0.6896	-0.0780	0.0711	-0.6931	-0.0172	0.4754	0.0019	04.30	-(0.01	0.0024	0.0020	0.0016	180.0	-0.0025
028	0.434	0.751	02.17	0.4399	-0.0742	0.0459	-0.4415	-0.0275	0.1934	0.0018	02.17	-(0.01	0.0039	0.0023	0.0012	180.0	-0.0040
029	0.437	0.748	00.04	0.1973	-0.0668	0.0370	-0.1974	-0.0353	0.0388	0.0016	00.04	-(0.01	0.0045	0.0025	0.0009	180.0	-0.0046
030	0.414	0.701	06.31	0.8071	-0.1087	0.1069	-0.8141	-0.0156	0.6514	0.0020	06.31	-(0.01	0.0029	0.0024	0.0040	180.0	-0.0030
031	0.416	0.701	04.25	0.6473	-0.0765	0.0654	-0.6505	-0.0153	0.4188	0.0019	04.25	-(0.01	0.0037	0.0025	0.0023	180.0	-0.0038
032	0.414	0.700	02.14	0.4182	-0.0720	0.0460	-0.4197	-0.0287	0.1747	0.0017	02.14	-(0.01	0.0035	0.0022	0.0012	180.0	-0.0036
033	0.414	0.699	00.04	0.1889	-0.0636	0.0399	-0.1890	-0.0342	0.0396	0.0017	00.04	-(0.01	0.0049	0.0024	0.0009	180.0	-0.0046
037	0.434	0.501	06.23	0.7459	-0.0889	0.0916	-0.7516	-0.0079	0.5563	0.0023	06.23	-(0.01	0.0019	0.0026	0.0017	180.0	-0.0020
037	0.434	0.501	06.23	0.7459	-0.0889	0.0916	-0.7516	-0.0079	0.5563	0.0023	06.23	-(0.01	0.0019	0.0026	0.0017	180.0	-0.0020
038	0.431	0.500	04.16	0.5634	-0.0753	0.0574	-0.5662	-0.0144	0.3173	0.0019	04.16	-(0.01	0.0028	0.0027	0.0022	180.0	-0.0029

TABLE 3(F)
 CLEAR AIRCRAFT
 ETA = +10° ETRACT = +172°

SER	REVN.	MACH.	INCID.	LIFT.	PITCH.	DRAG	NORMAL	AXIAL.	CLSD.	BASE.	AINC.	SLIP.	CROSS.	YAW M.	ROLL M	RANG.	SIDE F
002	0.460	0.901	06.35	0.7795	-0.1369	0.1484	-0.7912	-0.0588	0.6074	0.0023	06.35	-00.01	0.0007	0.0012	-0.0010	179.9	-0.0008
003	0.457	0.899	04.24	0.6482	-0.1638	0.1051	-0.6543	-0.0550	0.4200	0.0019	04.24	-00.01	0.0007	0.0011	0.0002	180.0	-0.0008
004	0.457	0.899	02.10	0.4782	-0.2002	0.0728	-0.4806	-0.0533	0.2285	0.0020	02.10	-00.01	0.0034	0.0020	0.0010	180.0	-0.0035
005	0.460	0.901	00.05	0.2364	-0.1887	0.0542	-0.2364	-0.0524	0.0557	0.0020	00.05	-00.02	0.0042	0.0024	0.0007	180.0	-0.0043
006	0.453	0.879	06.34	0.7876	-0.1456	0.1378	-0.7982	-0.0479	0.6203	0.0020	06.34	-00.01	0.0007	0.0015	-0.0010	179.9	-0.0007
007	0.453	0.880	04.24	0.6608	-0.1699	0.0946	-0.6661	-0.0436	0.4265	0.0019	04.24	-00.01	-0.0001	0.0011	0.0001	180.0	0.0000
008	0.453	0.879	02.11	0.4988	-0.1968	0.0673	-0.5010	-0.0471	0.2486	0.0018	02.11	-00.01	0.0039	0.0022	0.0011	180.0	-0.0040
009	0.453	0.880	00.02	0.2640	-0.1817	0.0490	-0.2640	-0.0472	0.0696	0.0019	00.02	-00.01	0.0046	0.0023	0.0008	180.0	-0.0047
012	0.460	0.899	06.36	0.7973	-0.1385	0.1346	-0.8074	-0.0435	0.6355	0.0020	06.36	-00.01	0.0017	0.0018	-0.0004	179.9	-0.0018
013	0.462	0.861	04.25	0.6726	-0.1629	0.0944	-0.6779	-0.0423	0.4523	0.0019	04.25	-00.01	0.0018	0.0017	0.0004	180.0	-0.0019
014	0.460	0.860	02.13	0.5172	-0.1884	0.0623	-0.5193	-0.0412	0.2673	0.0018	02.13	-00.02	0.0039	0.0025	0.0013	180.0	-0.0040
015	0.463	0.861	00.01	0.2642	-0.1673	0.0452	-0.2643	-0.0434	0.0697	0.0018	00.01	-00.02	0.0052	0.0030	0.0010	180.0	-0.0053
016	0.453	0.839	06.34	0.7977	-0.1422	0.1261	-0.8069	-0.0351	0.6362	0.0021	06.34	-00.01	0.0015	0.0018	0.0003	180.0	-0.0016
017	0.453	0.840	04.26	0.6948	-0.1658	0.0888	-0.6996	-0.0351	0.4826	0.0019	04.26	-00.01	0.0010	0.0014	0.0003	180.0	-0.0011
018	0.453	0.840	02.14	0.5257	-0.1767	0.0599	-0.5277	-0.0385	0.2762	0.0017	02.14	-00.02	0.0040	0.0025	0.0012	180.0	-0.0041
019	0.453	0.838	00.00	0.2534	-0.1950	0.0410	-0.2535	-0.0395	0.0641	0.0016	00.00	-00.02	0.0041	0.0025	0.0009	180.0	-0.0042
022	0.470	0.800	06.34	0.8094	-0.1448	0.1232	-0.8181	-0.0311	0.6550	0.0019	06.34	-00.01	0.0014	0.0017	0.0010	180.0	-0.0015
023	0.470	0.800	04.29	0.7325	-0.1552	0.0834	-0.7368	-0.0265	0.5365	0.0018	04.29	-00.02	0.0046	0.0027	0.0009	180.0	-0.0047
024	0.467	0.798	02.15	0.5023	-0.1556	0.0517	-0.5040	-0.0314	0.2522	0.0015	02.15	-00.01	0.0031	0.0020	0.0013	180.0	-0.0032
025	0.470	0.800	00.00	0.2377	-0.1478	0.0403	-0.2378	-0.0389	0.0564	0.0015	00.00	-00.02	0.0050	0.0028	0.0010	180.0	-0.0051
026	0.449	0.750	06.31	0.8351	-0.1662	0.1155	-0.8429	-0.0212	0.6973	0.0018	06.31	-00.01	0.0046	0.0025	0.0036	180.0	-0.0047
027	0.449	0.750	04.25	0.7173	-0.1539	0.0740	-0.7209	-0.0189	0.5145	0.0016	04.25	-00.01	0.0033	0.0021	0.0015	180.0	-0.0034
028	0.449	0.751	02.12	0.4707	-0.1501	0.0487	-0.4723	-0.0296	0.2314	0.0016	02.12	-00.02	0.0045	0.0027	0.0012	180.0	-0.0046
029	0.449	0.750	00.00	0.2262	-0.1412	0.0388	-0.2263	-0.0373	0.0511	0.0016	00.00	-00.01	0.0052	0.0027	0.0010	180.0	-0.0053
030	0.426	0.700	06.27	0.8353	-0.1758	0.1108	-0.8426	-0.0170	0.6976	0.0019	06.27	-00.01	0.0037	0.0025	0.0040	180.0	-0.0038
031	0.426	0.699	04.21	0.6745	-0.1519	0.0674	-0.6777	-0.0160	0.4548	0.0017	04.21	-00.01	0.0047	0.0025	0.0022	180.0	-0.0048
032	0.429	0.700	02.10	0.4485	-0.1462	0.0472	-0.4501	-0.0291	0.2011	0.0016	02.10	-00.01	0.0037	0.0027	0.0012	180.0	-0.0038
033	0.426	0.699	00.00	0.2184	-0.1362	0.0392	-0.2185	-0.0377	0.0476	0.0016	00.00	-00.01	0.0051	0.0028	0.0008	180.0	-0.0052
036	0.447	0.500	06.20	0.7751	-0.1586	0.0955	-0.7810	-0.0092	0.6007	0.0020	06.20	-00.01	0.0018	0.0027	0.0017	180.0	-0.0019
037	0.447	0.500	04.13	0.5938	-0.1453	0.0610	-0.5968	-0.0160	0.3525	0.0020	04.13	-00.01	0.0035	0.0027	0.0021	180.0	-0.0036
038	0.447	0.499	02.07	0.4012	-0.1350	0.0436	-0.4026	-0.0275	0.1609	0.0016	02.07	-00.01	0.0044	0.0024	0.0014	180.0	-0.0048
039	0.449	0.501	00.00	0.1993	-0.1237	0.0362	-0.1994	-0.0346	0.0396	0.0017	00.00	-00.01	0.0048	0.0025	0.0011	180.0	-0.0049

TABLE 4
CLEAN AIRCRAFT
TAILPLANE OFF

SER	REYN.	MACH.	INCID.	LIFT.	PITCH.	DRAG	NORMAL	AXIAL.	CLSQ.	BASE.	AINC.	SLIP.	CROSS.	YAW M.	ROLL M	RANG.	SIDE F
076	0.457	0.900	00.05	0.2218	-0.0816	0.0475	-0.2320	-0.0447	0.0491	0.0013	00.05	04.05	0.0174	-0.0074	0.0013	-090.0	-0.0208
077	0.457	0.900	00.05	0.2115	-0.0815	0.0474	-0.2317	-0.0452	0.0447	0.0017	00.05	02.02	0.0066	-0.0039	0.0007	-090.0	-0.0103
078	0.457	0.900	00.05	0.2148	-0.0817	0.0469	-0.2350	-0.0451	0.0461	0.0015	00.05	01.01	0.0043	-0.0021	0.0004	-090.0	-0.0052
079	0.460	0.902	00.04	0.2071	-0.0818	0.0475	-0.2073	-0.0456	0.0428	0.0018	00.04	00.00	0.0003	-0.0001	0.0002	-090.0	-0.0004
082	0.462	0.800	00.08	0.2111	-0.0383	0.0363	-0.2112	-0.0335	0.0444	0.0012	00.08	04.05	0.0160	-0.0071	0.0006	-090.0	-0.0206
083	0.458	0.800	00.08	0.2114	-0.0381	0.0346	-0.2116	-0.0326	0.0446	0.0013	00.08	02.02	0.0085	-0.0037	0.0004	-090.0	-0.0099
084	0.460	0.803	00.08	0.2125	-0.0384	0.0345	-0.2126	-0.0326	0.0450	0.0015	00.08	01.01	0.0042	-0.0019	0.0003	-090.0	-0.0049
085	0.458	0.798	00.08	0.2109	-0.0381	0.0341	-0.2110	-0.0326	0.0443	0.0013	00.08	00.00	0.0000	-0.0001	0.0003	-090.0	-0.0001
088	0.444	0.501	00.04	0.1654	-0.0281	0.0327	-0.1655	-0.0294	0.0273	0.0014	00.04	04.03	0.0177	-0.0068	0.0008	-090.0	-0.0201
089	0.444	0.500	00.04	0.1653	-0.0273	0.0312	-0.1655	-0.0294	0.0272	0.0014	00.04	02.01	0.0083	-0.0035	0.0005	-090.0	-0.0095
090	0.444	0.499	00.04	0.1647	-0.0270	0.0306	-0.1648	-0.0289	0.0270	0.0016	00.04	01.00	0.0041	-0.0018	0.0004	-090.0	-0.0048
091	0.444	0.499	00.04	0.1648	-0.0269	0.0308	-0.1650	-0.0293	0.0271	0.0014	00.04	00.00	0.0000	-0.0001	0.0003	-090.0	-0.0001

TABLE 4
CLEAN AIRCRAFT
TAILPLANE OFF

SER	REYN.	MACH.	INCID.	LIFT.	PITCH.	DRAW	NORMAL	AXIAL.	CLSQ.	BASE.	AIRC.	SLIP.	CROSS.	YAW M.	ROLL M	RANG.	SIDE F
002	0.442	0.899	07.45	0.8496	-0.0759	0.1641	-0.8638	-0.0509	0.7216	0.0017	07.45	-00.01	-0.0036	-0.0001	-0.0008	179.9	0.0035
003	0.444	0.901	06.40	0.7776	-0.0761	0.1367	-0.7881	-0.0472	0.6046	0.0019	06.40	-00.01	-0.0036	-0.0006	-0.0022	179.9	0.0035
004	0.444	0.899	05.35	0.7067	-0.0770	0.1131	-0.7143	-0.0448	0.4952	0.0018	05.35	00.00	-0.0030	-0.0007	-0.0008	179.9	0.0029
005	0.444	0.901	04.30	0.6310	-0.0824	0.0944	-0.6364	-0.0449	0.3980	0.0019	04.30	00.00	-0.0025	-0.0005	0.0004	180.0	0.0024
006	0.444	0.900	03.25	0.5423	-0.0831	0.0777	-0.5460	-0.0449	0.2939	0.0019	03.25	00.00	-0.0011	-0.0003	0.0011	180.0	0.0010
007	0.444	0.900	01.11	0.3278	-0.0858	0.0534	-0.3289	-0.0454	0.1073	0.0017	01.11	-00.01	-0.0008	0.0001	0.0014	180.0	0.0007
008	0.444	0.901	-01.03	0.0640	-0.0673	0.0435	-0.0633	-0.0430	0.0040	0.0017	-01.03	-00.01	0.0011	0.0008	0.0016	180.0	-0.0012
009	0.444	0.899	-03.18	-0.2278	-0.0385	0.0514	0.2302	-0.0372	0.0517	0.0016	-03.18	00.00	0.0020	0.0000	0.0019	180.0	-0.0021
012	0.455	0.801	07.44	0.7991	-0.0300	0.1363	-0.8101	-0.0303	0.6384	0.0013	07.44	00.00	-0.0037	-0.0013	0.0018	180.0	0.0036
013	0.455	0.801	06.42	0.7710	-0.0260	0.1156	-0.7792	-0.0271	0.5943	0.0015	06.42	00.00	-0.0028	-0.0007	0.0029	180.0	0.0027
014	0.455	0.799	05.41	0.7490	-0.0267	0.0939	-0.7546	-0.0213	0.5609	0.0015	05.41	-00.01	-0.0026	-0.0002	0.0004	180.0	0.0025
015	0.455	0.799	04.37	0.6848	-0.0236	0.0737	-0.6886	-0.0197	0.4689	0.0016	04.37	-00.01	-0.0030	-0.0002	0.0012	180.0	0.0029
016	0.455	0.801	03.32	0.5859	-0.0235	0.0584	-0.5884	-0.0226	0.3832	0.0018	03.32	-00.01	-0.0010	0.0002	0.0021	180.0	0.0009
017	0.455	0.800	01.16	0.3316	-0.0333	0.0377	-0.3324	-0.0296	0.1099	0.0014	01.16	-00.01	-0.0006	0.0005	0.0017	180.0	0.0005
018	0.455	0.800	-01.00	0.0779	-0.0440	0.0322	-0.0774	-0.0322	0.0060	0.0015	-01.00	-00.01	0.0001	0.0001	0.0016	180.0	-0.0002
019	0.455	0.801	-03.16	-0.1736	-0.0568	0.0348	0.1751	-0.0238	0.0300	0.0014	-03.16	-00.01	0.0012	0.0002	0.0019	180.0	-0.0013
022	0.444	0.903	07.29	0.7623	-0.0066	0.1107	-0.7703	-0.0111	0.5810	0.0021	07.29	-00.01	-0.0017	0.0005	0.0030	180.0	0.0016
023	0.444	0.900	06.27	0.7101	0.0039	0.0861	-0.7154	-0.0064	0.5042	0.0017	06.27	-00.01	-0.0017	0.0006	0.0024	180.0	0.0016
024	0.440	0.900	05.24	0.6247	0.0035	0.0654	-0.6282	-0.0062	0.3901	0.0019	05.24	-00.01	-0.0016	0.0006	0.0024	180.0	0.0015
025	0.440	0.901	04.20	0.5361	-0.0029	0.0526	-0.5386	-0.0115	0.2872	0.0018	04.20	-00.01	-0.0009	0.0005	0.0029	180.0	0.0008
026	0.440	0.900	03.16	0.4460	-0.0104	0.0434	-0.4478	-0.0169	0.1987	0.0019	03.16	-00.01	0.0001	0.0007	0.0026	180.0	-0.0002
027	0.440	0.901	01.08	0.2591	-0.0225	0.0332	-0.2598	-0.0269	0.0670	0.0015	01.08	-00.01	-0.0003	0.0002	0.0018	180.0	0.0002
028	0.440	0.901	-01.00	0.0650	-0.0333	0.0297	-0.0646	-0.0293	0.0041	0.0016	-01.00	-00.01	0.0005	0.0002	0.0019	180.0	-0.0006
029	0.440	0.499	-03.08	-0.1243	-0.0430	0.0319	0.1257	-0.0237	0.0153	0.0015	-03.08	00.00	0.0008	-0.0001	0.0020	180.0	-0.0009

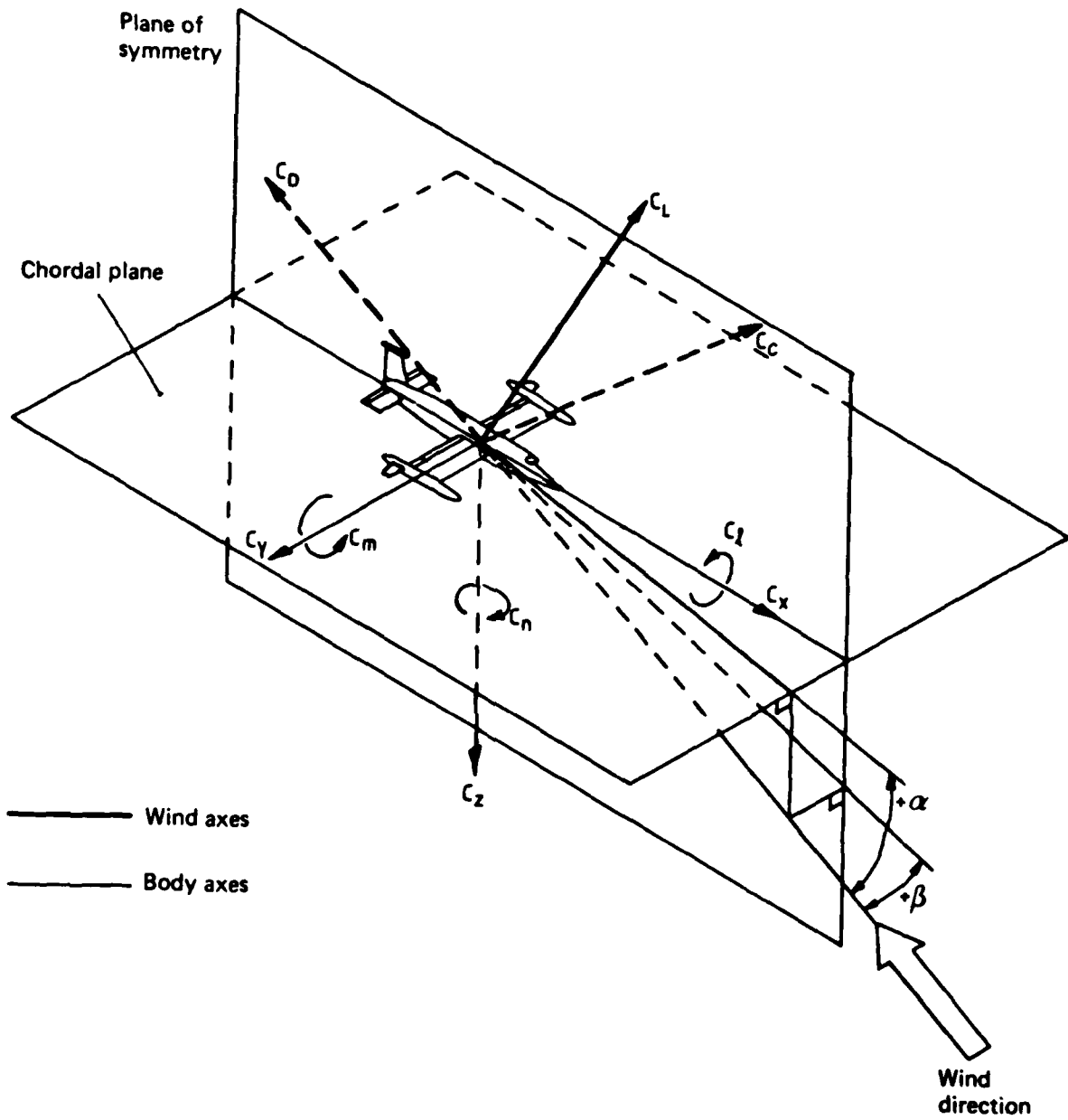

FIG. 1 FORCE AND MOMENT AXES SYSTEM

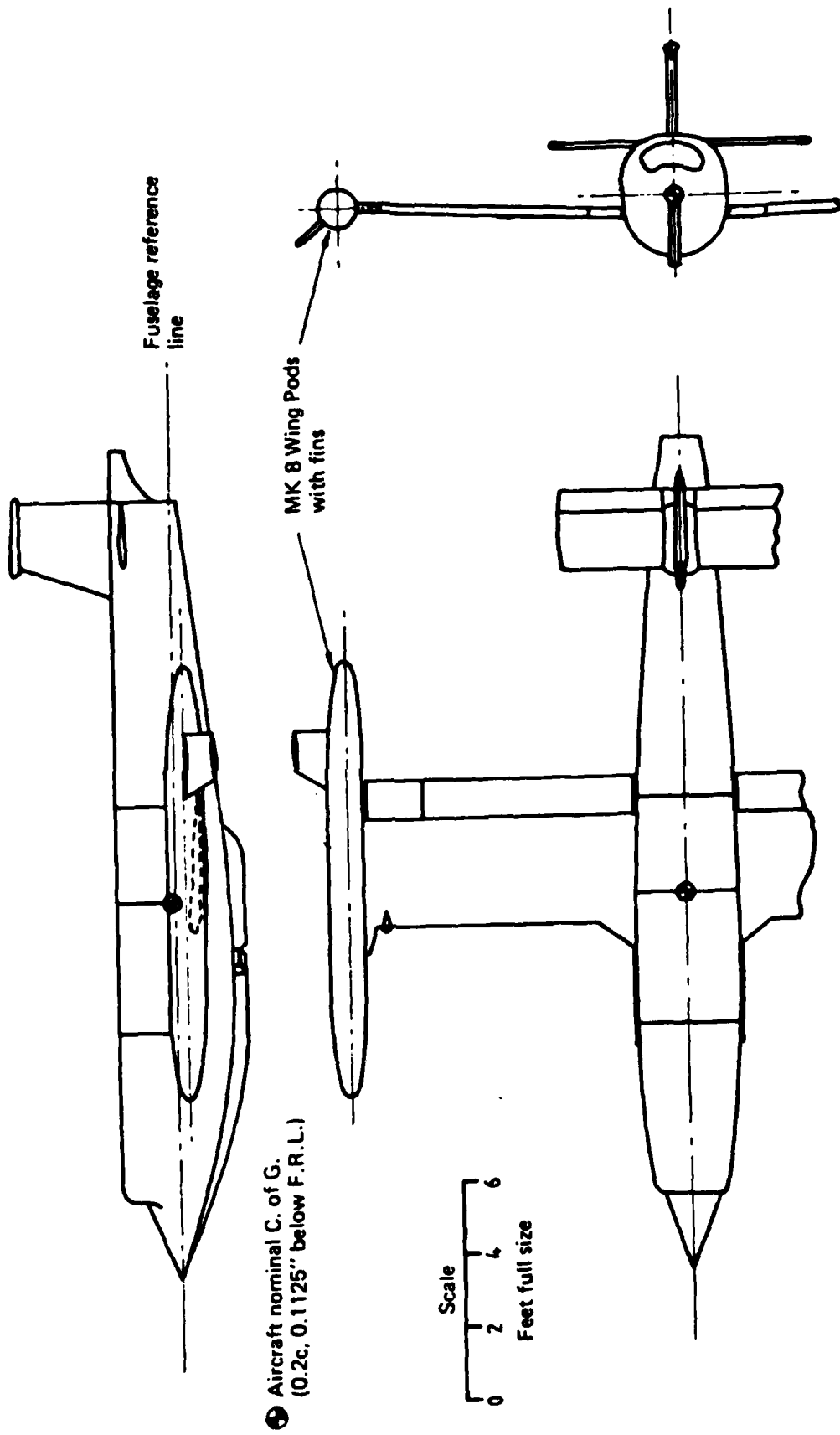

FIG. 2 SKETCH OF MODEL



FIG. 3 PHOTOGRAPH OF MODEL

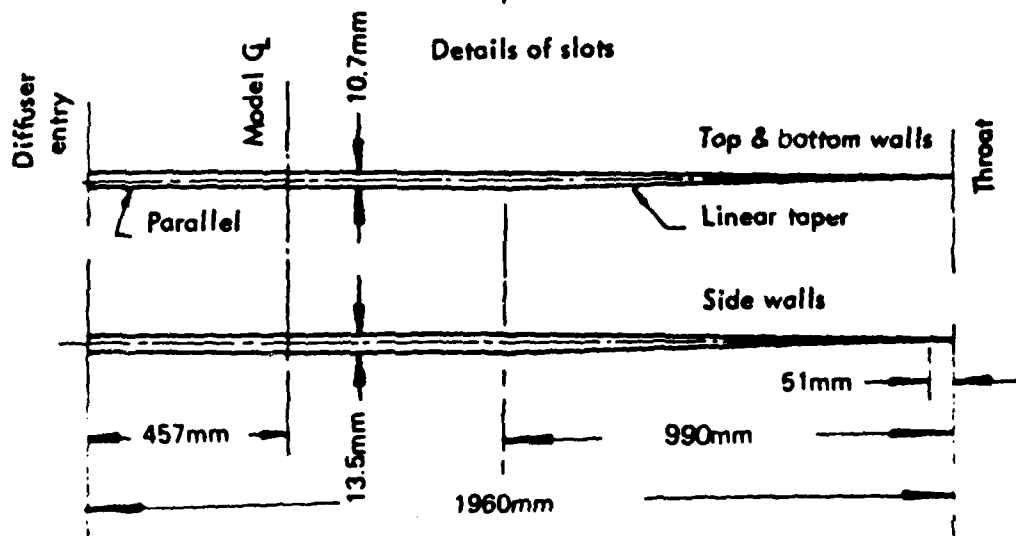
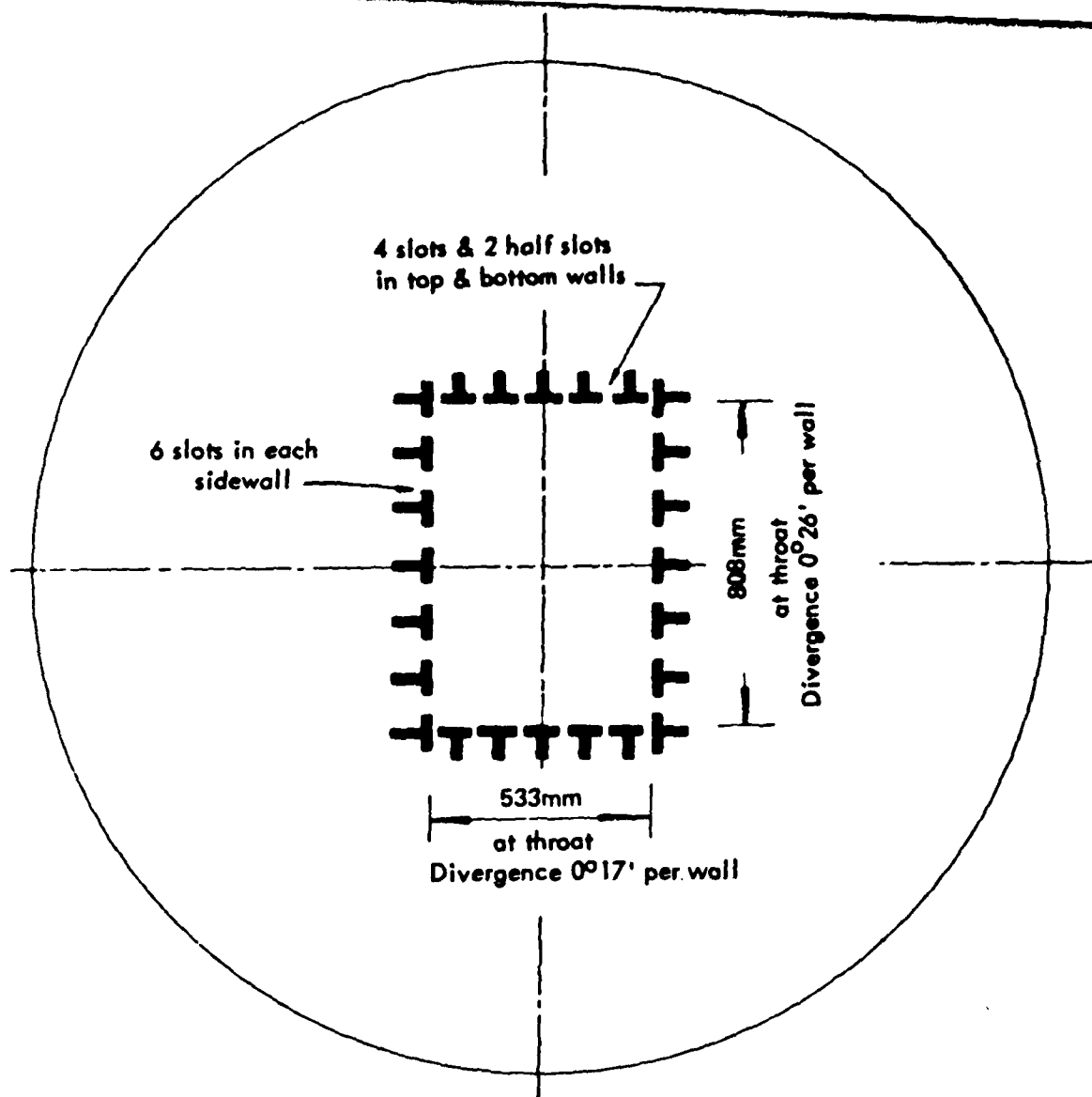
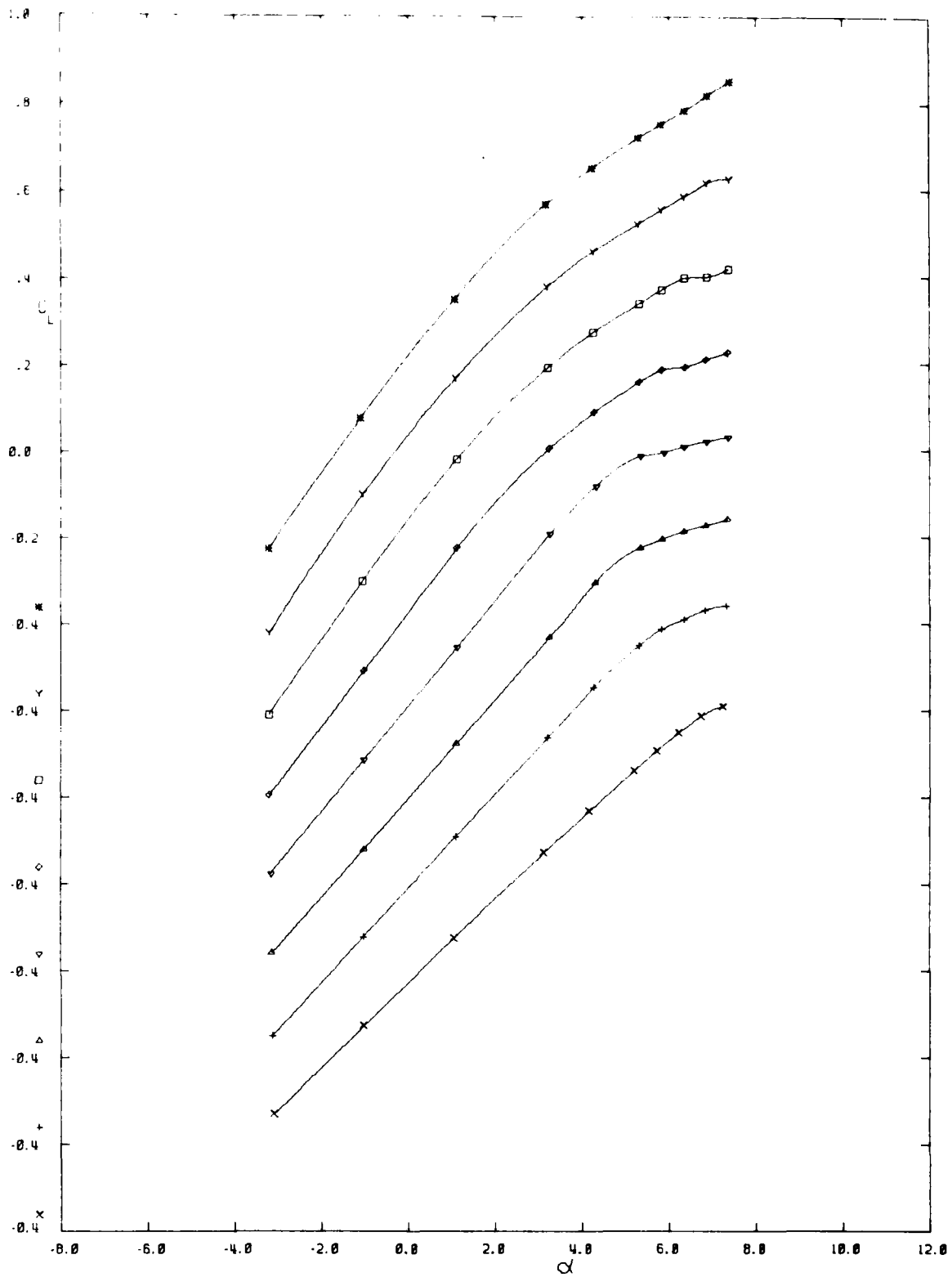
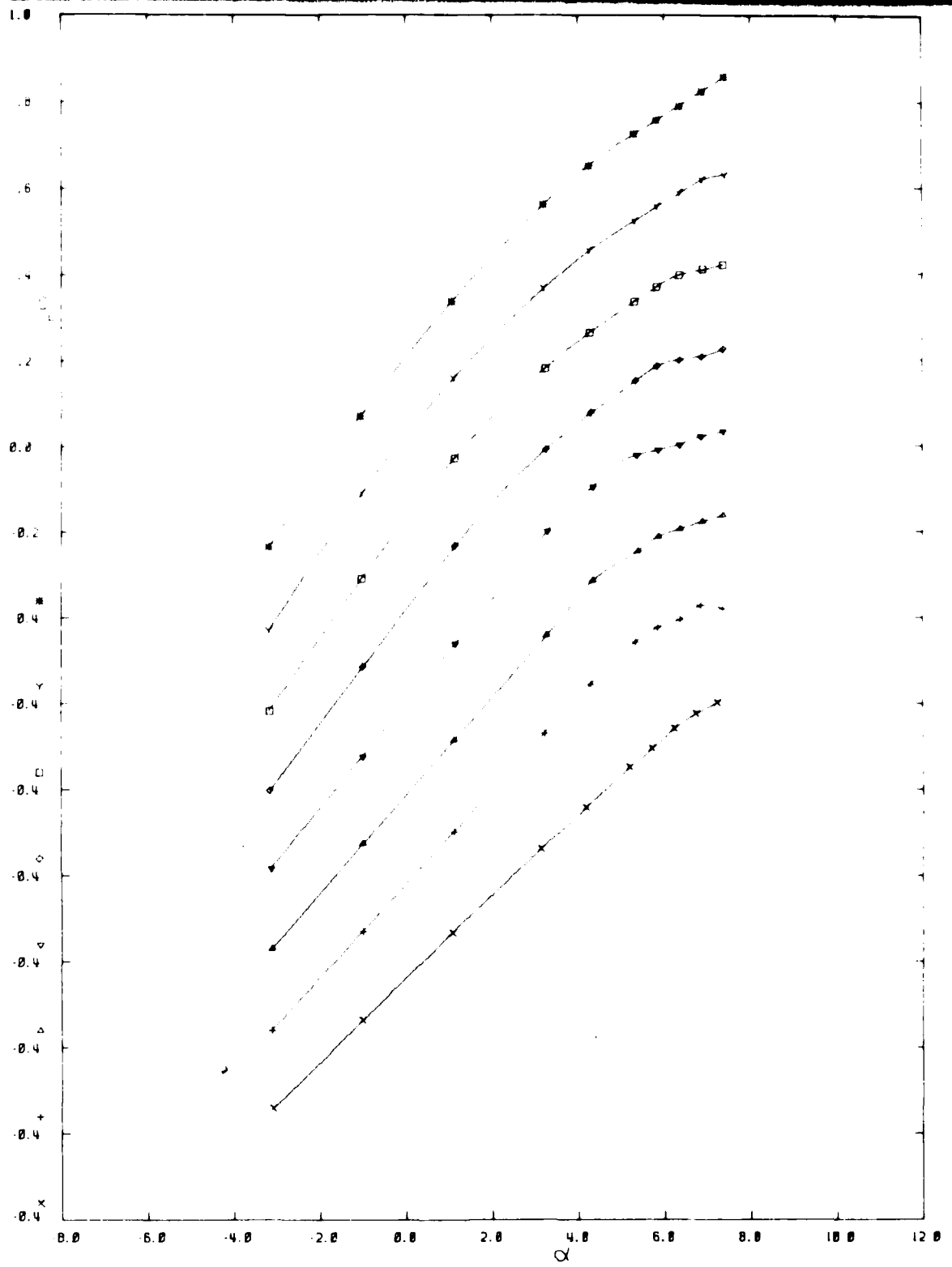

FIG. 4 DETAILS OF SLOTTED TEST SECTION



SYMBOL	M
x	.50
+	.70
△	.75
▽	.80
◇	.84
□	.86
Y	.88
■	.90

FIGURE 5(a)
 VARIATION OF LIFT COEFFICIENT WITH INCIDENCE
 $\eta_r = 3.5 \quad \eta = 0$



SYMBOL	M
x	.50
+	.70
△	.75
▽	.80
◇	.84
□	.86
γ	.88
*	.90

FIGURE 5(b)
 VARIATION OF LIFT COEFFICIENT WITH INCIDENCE
 $\eta_r = 2.5 \quad \eta = 0$

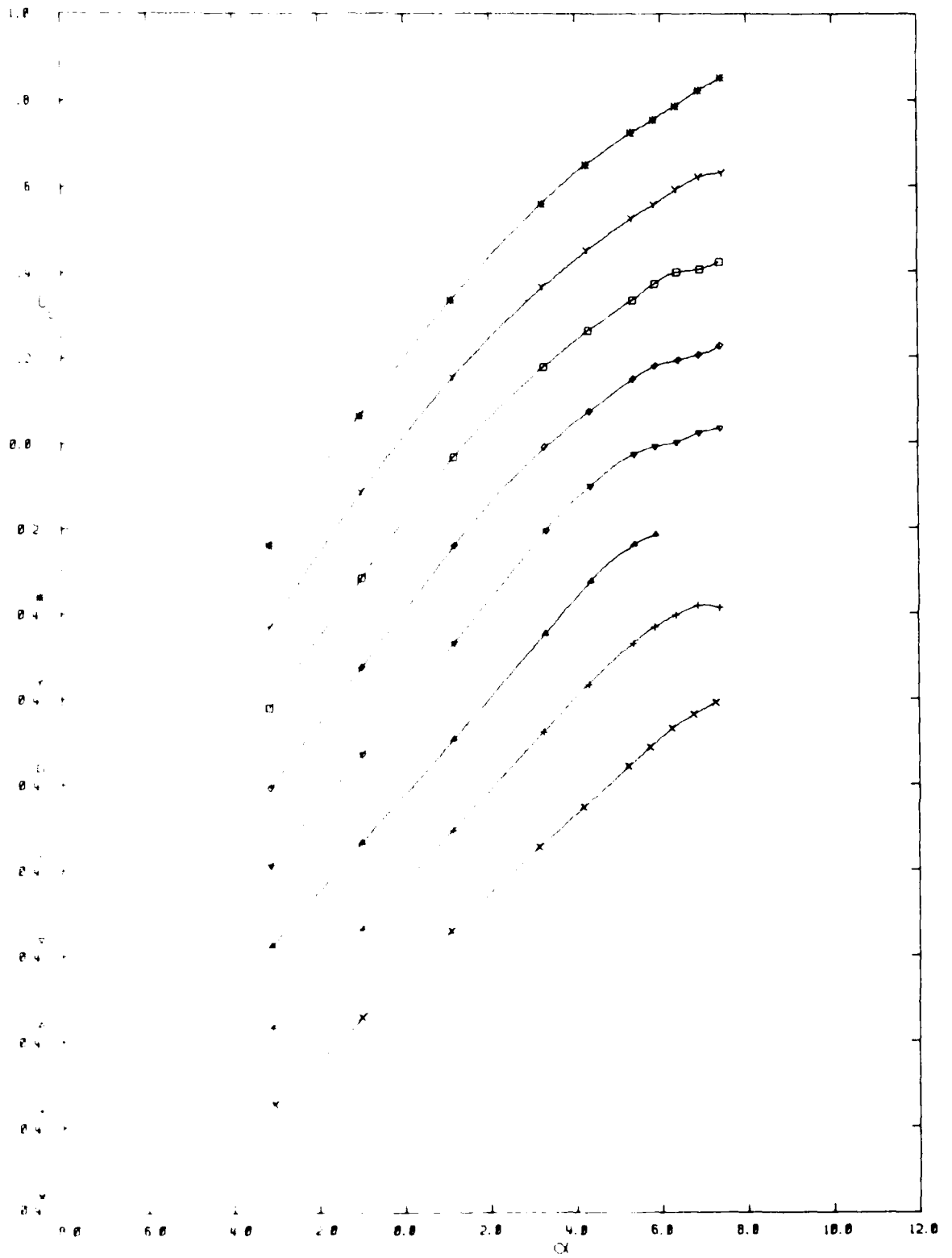

M
 ∇ 1.0
 \ast 1.1
 Δ 1.2
 \circ 1.4
 \square 1.6
 \times 1.8
 \bullet 2.0
 \diamond 2.2
 \cdot 2.4
 \circ 2.6

FIGURE 5(a)
 VARIATION OF LIFT COEFFICIENT WITH INCIDENCE.
 $\eta_T = 1.5 \quad \eta = 0$

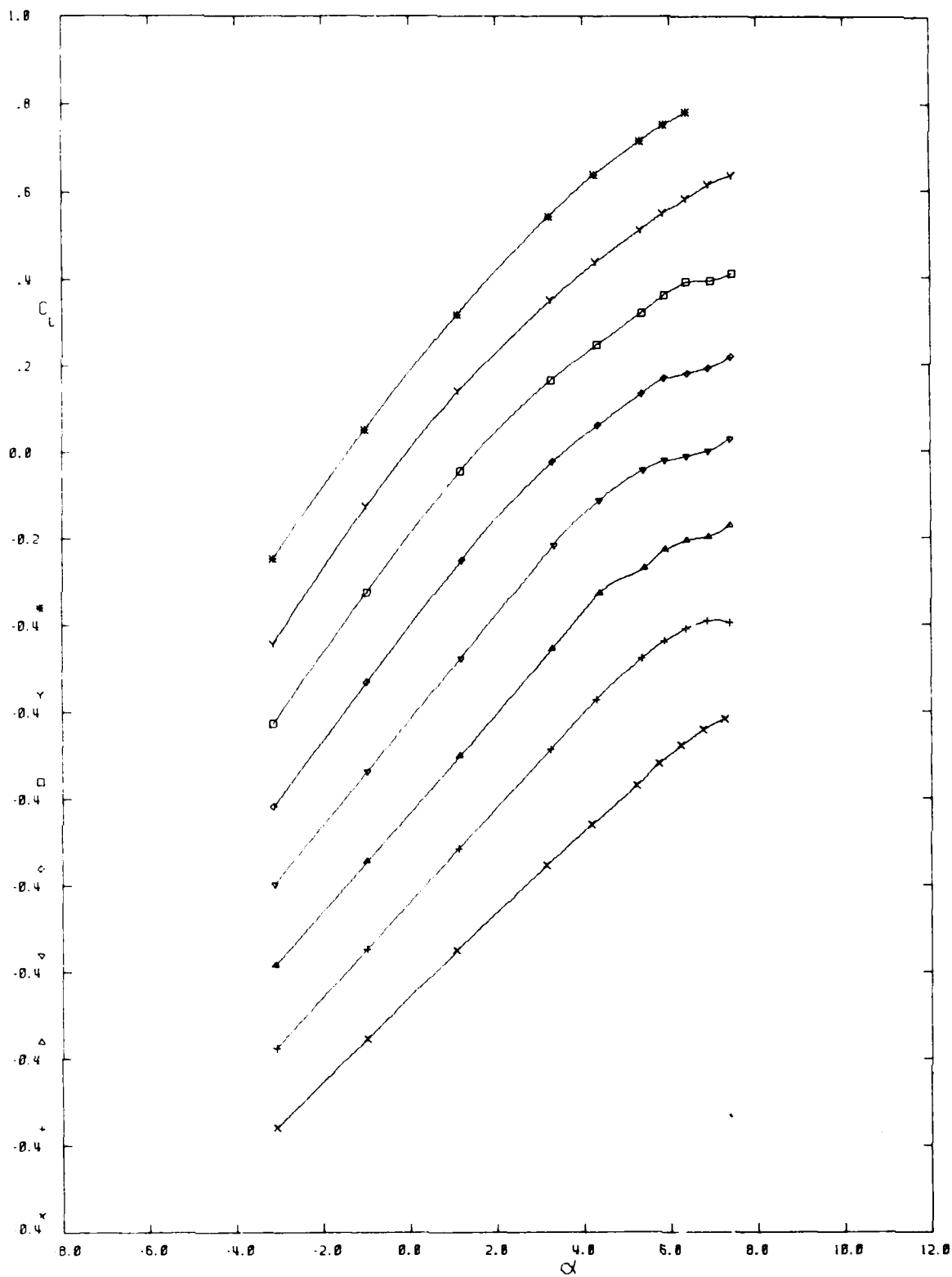

SYMBOL	M
x	.50
+	.70
△	.75
▽	.80
◇	.84
□	.86
Y	.88
*	.90

FIGURE 5(d)
 VARIATION OF LIFT COEFFICIENT WITH INCIDENCE.
 $\eta_r = 0.5 \quad \eta = 0$

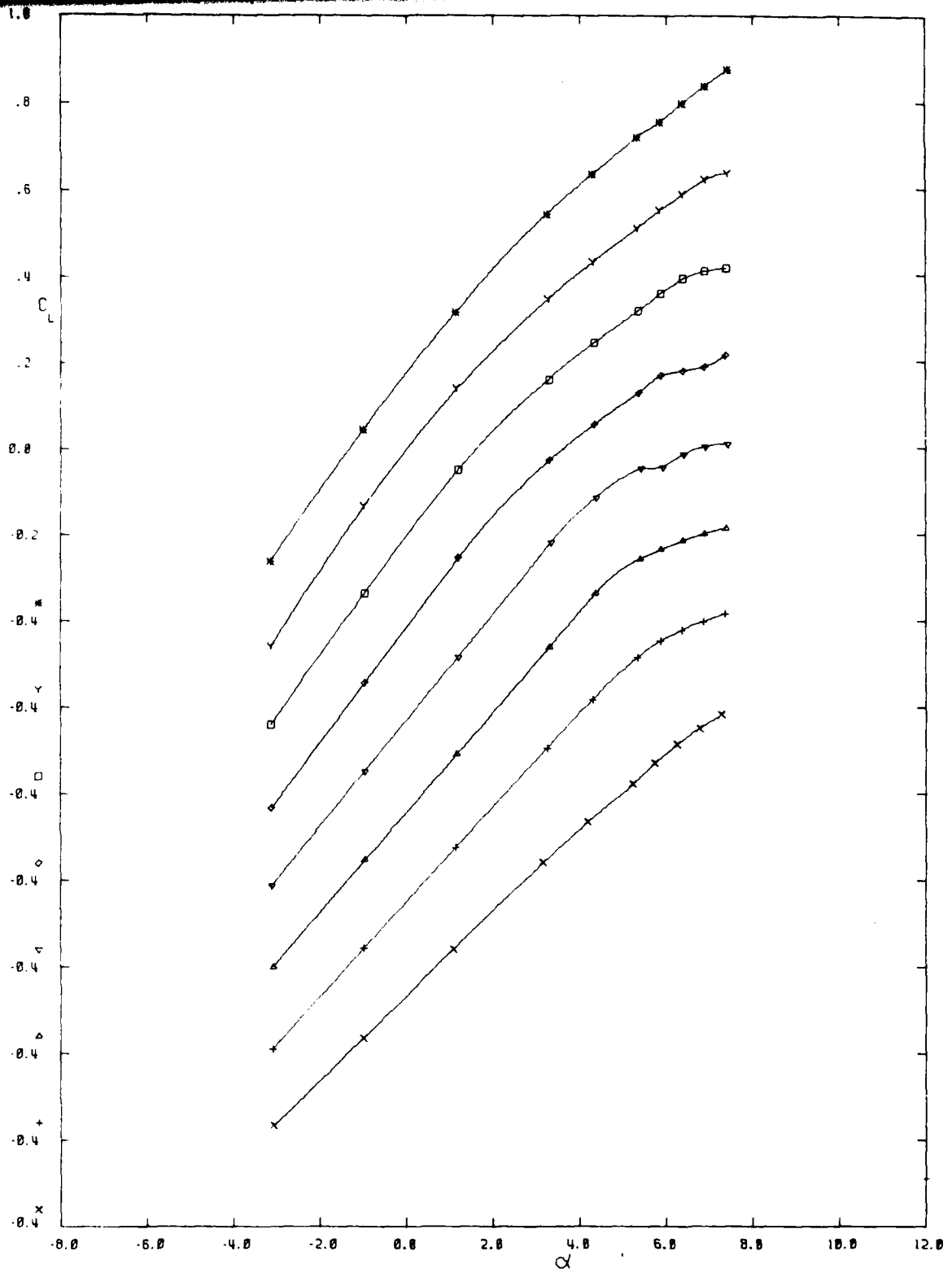

SYMBOL	M
x	.50
+	.70
△	.75
▽	.80
◇	.84
□	.86
Y	.88
*	.90

FIGURE 5(e)
 VARIATION OF LIFT COEFFICIENT WITH INCIDENCE.
 $\eta_r = -0.5 \quad \eta = 0$

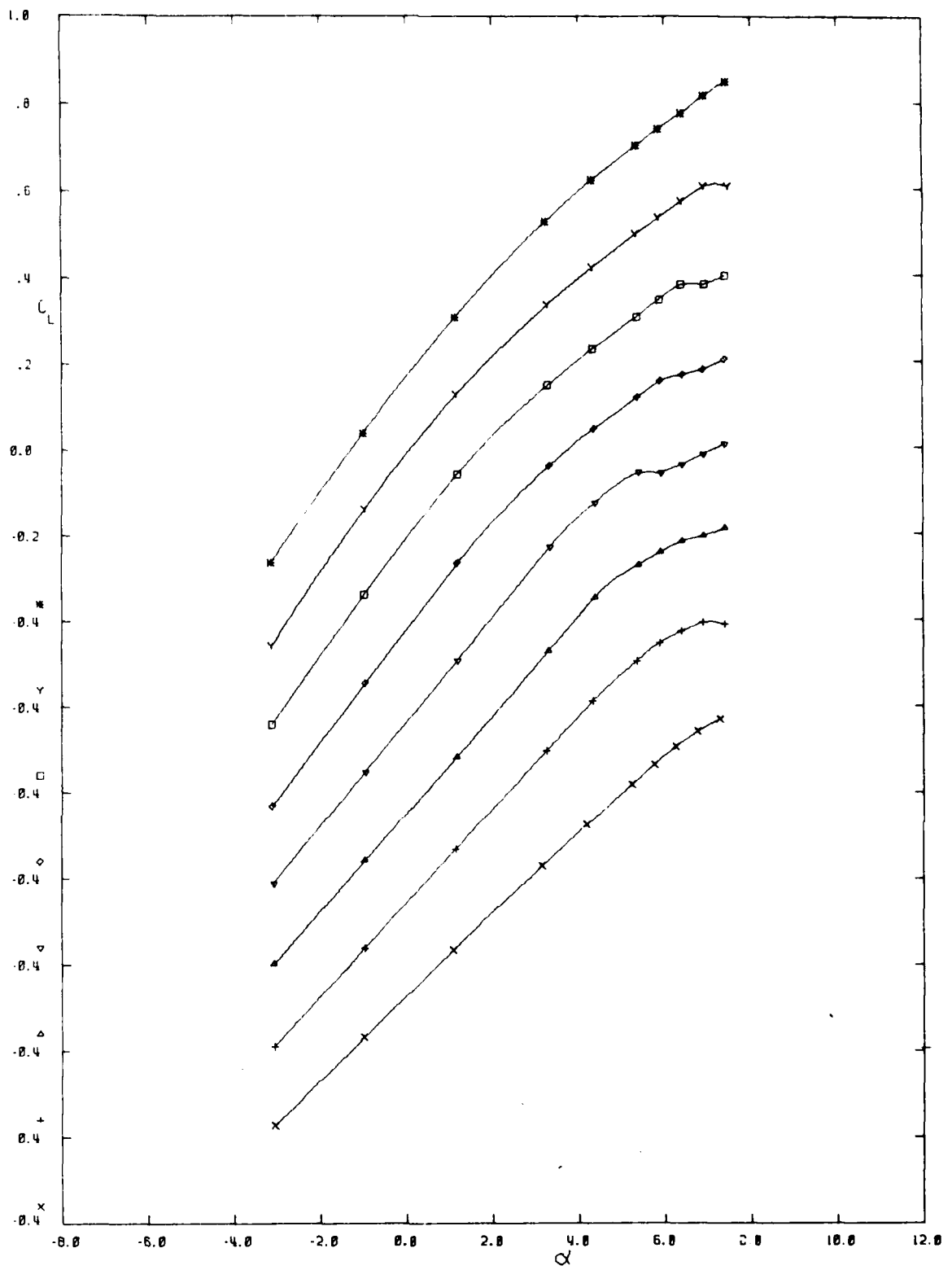

SYMBOL	M
x	.50
+	.70
△	.75
▽	.80
◇	.84
□	.86
Y	.88
*	.90

FIGURE 5(?)
 VARIATION OF LIFT COEFFICIENT WITH INCIDENCE.
 $\eta_r = -1.5 \quad \eta = 0$

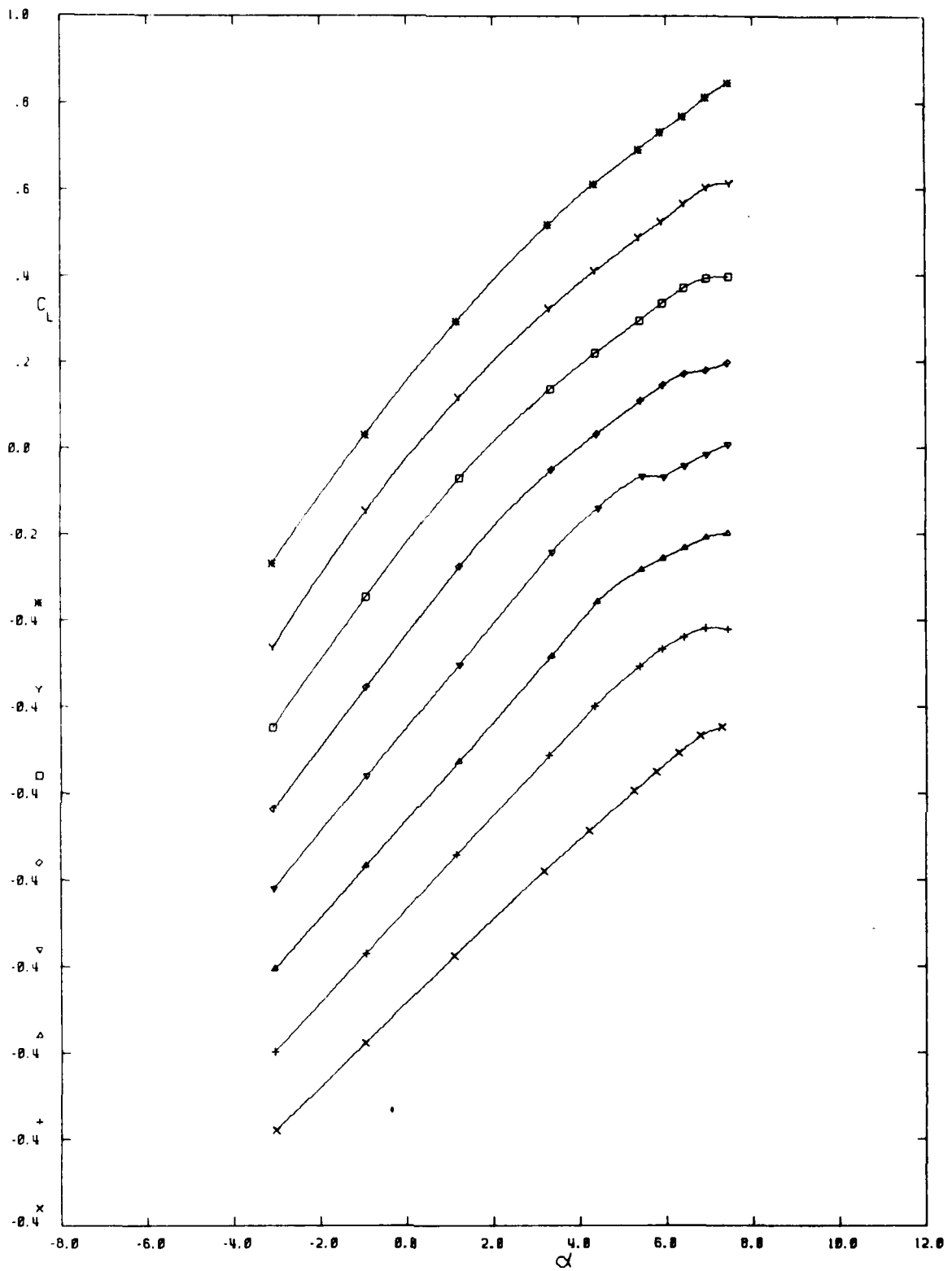

SYMBOL	M
x	.50
+	.70
△	.75
▽	.80
◇	.84
□	.86
Y	.88
*	.90

FIGURE 5(g)
 VARIATION OF LIFT COEFFICIENT WITH INCIDENCE.
 $\eta_r = -2.5 \quad \eta = 0$

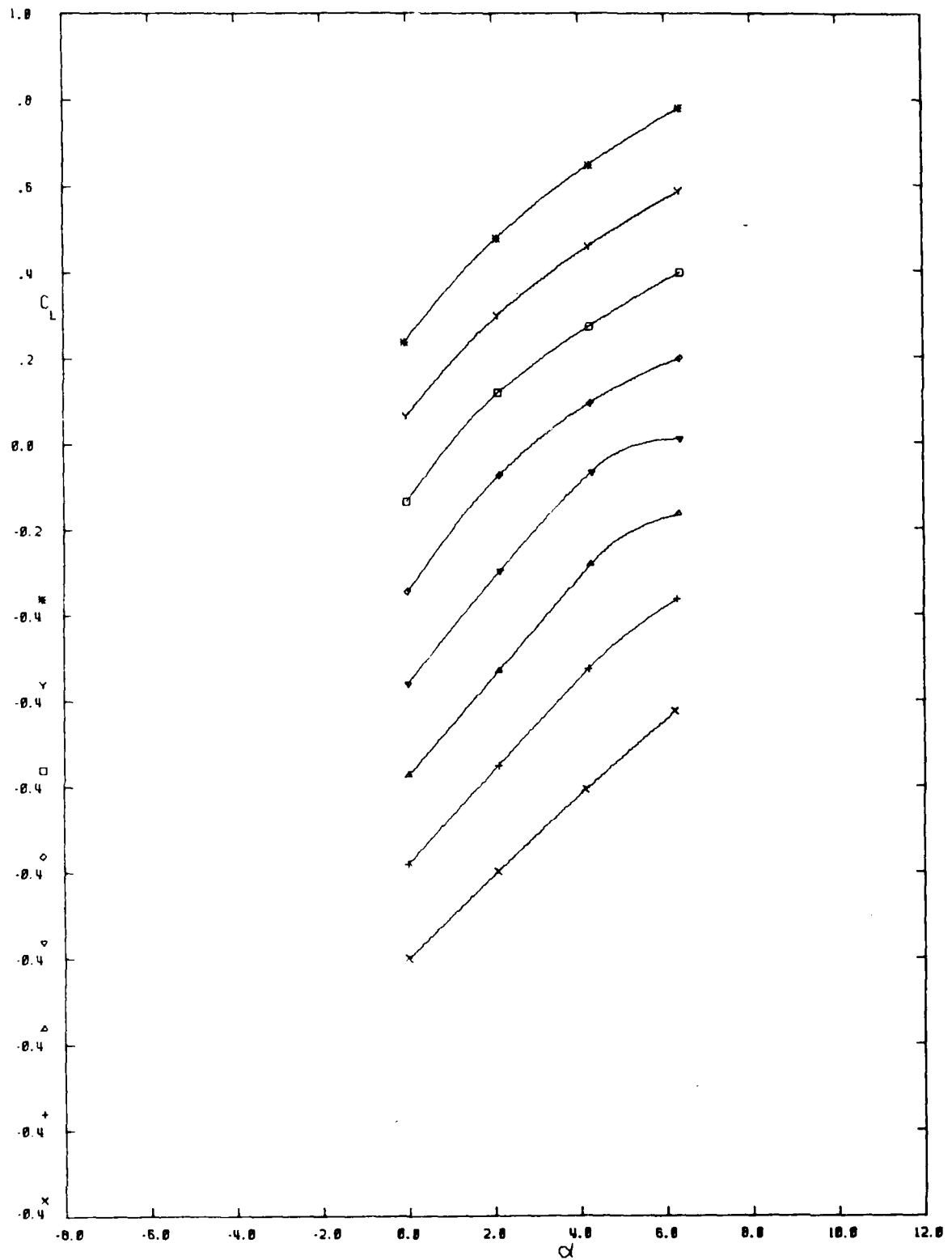

SYMBOL	M
x	.50
+	.70
Δ	.75
▽	.80
◇	.84
□	.86
Y	.88
*	.90

FIGURE 6(0)
 VARIATION OF LIFT COEFFICIENT WITH INCIDENCE.
 $\eta_r = 0.5 \quad \eta = 10$

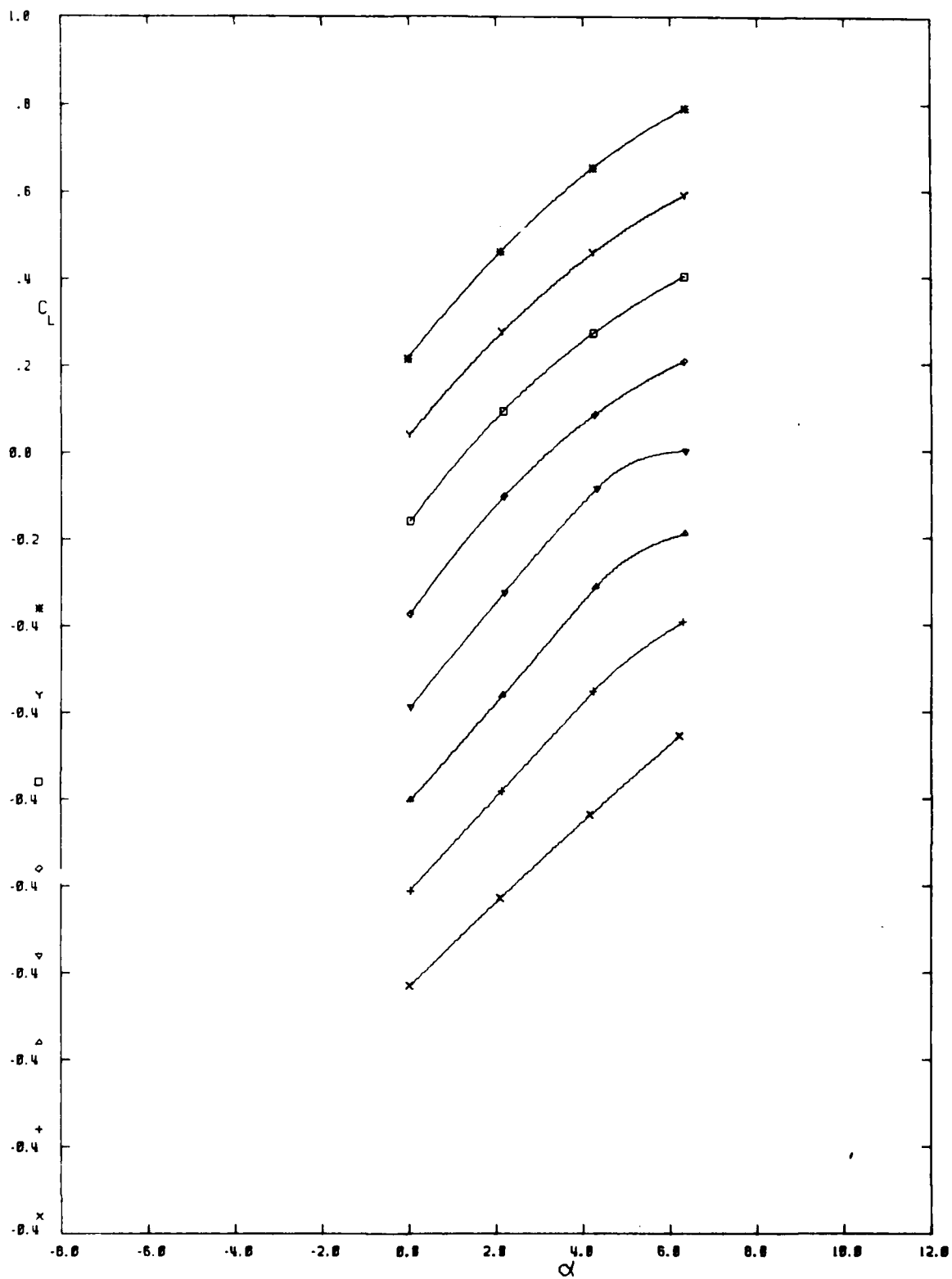

SYMBOL	M
x	.50
+	.70
△	.75
▽	.80
◇	.84
□	.86
Y	.88
⊗	.90

FIGURE 6(b)
 VARIATION OF LIFT COEFFICIENT WITH INCIDENCE.
 $\eta_r = 0.5 \quad \eta = 5$

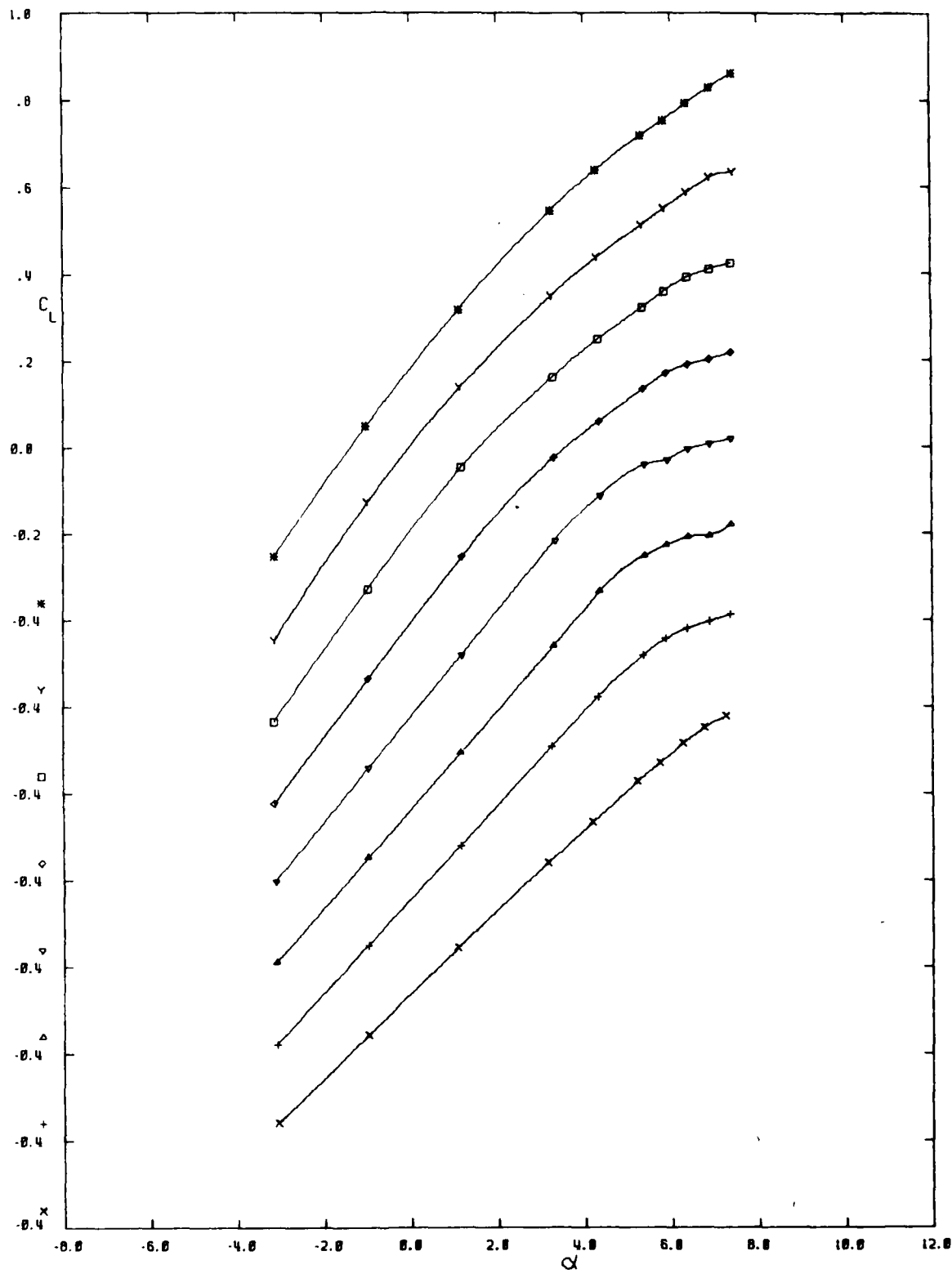

SYMBOL	M
x	.50
+	.70
△	.75
▽	.80
◇	.84
□	.86
Y	.88
■	.90

FIGURE 6(c)
 VARIATION OF LIFT COEFFICIENT WITH INCIDENCE.
 $\eta_r = 0.5 \quad \eta = 0$

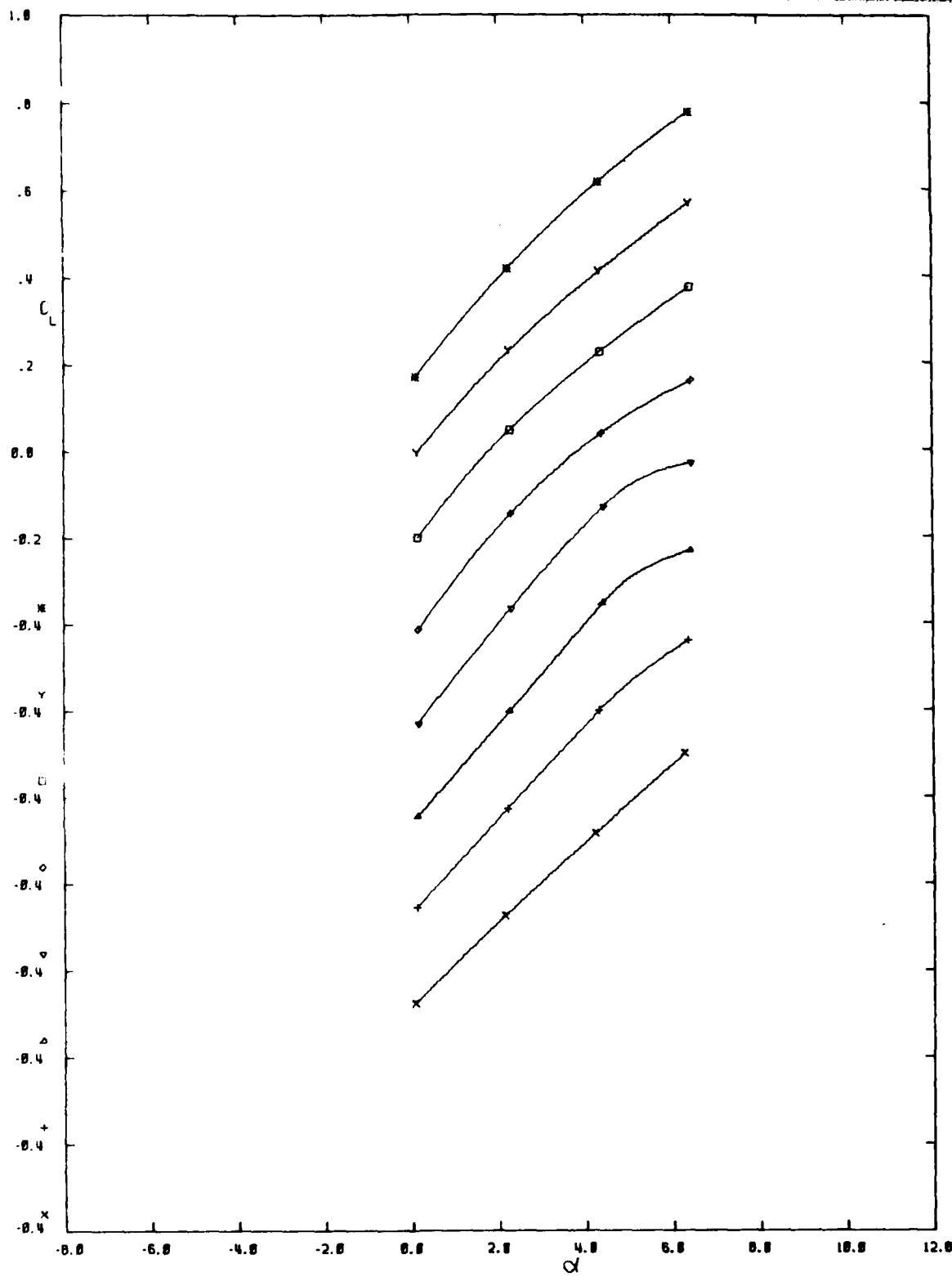

SYMBOL	M
x	.50
+	.70
△	.75
▽	.80
○	.84
□	.86
Y	.88
■	.90

FIGURE 6(d)
 VARIATION OF LIFT COEFFICIENT WITH INCIDENCE.
 $\eta_r = 0.5 \quad \eta = -5$

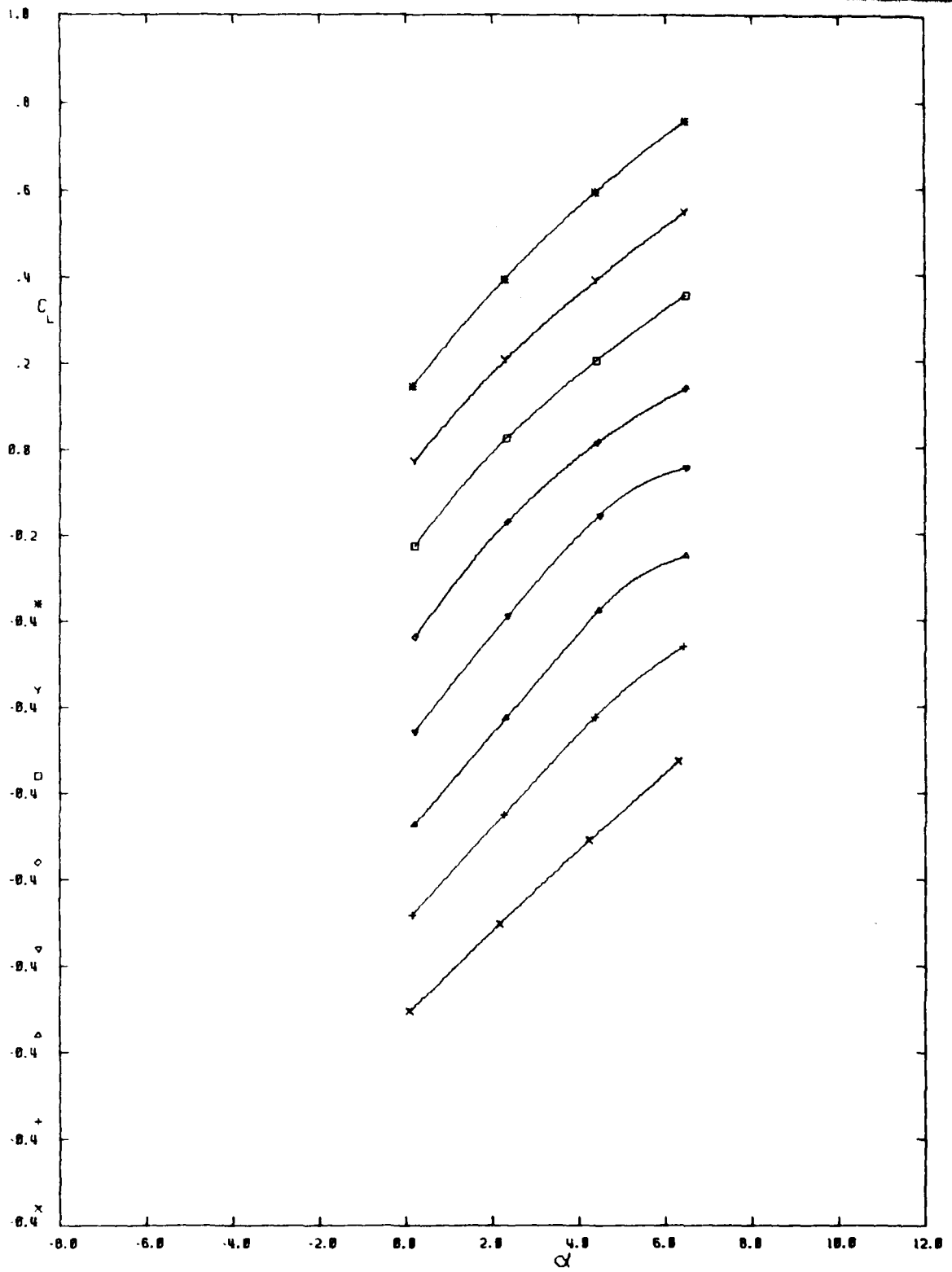

SYMBOL	M
x	.50
+	.70
Δ	.75
∇	.80
\diamond	.84
\square	.86
Y	.88
*	.90

FIGURE 6(a)
 VARIATION OF LIFT COEFFICIENT WITH INCIDENCE.
 $\eta_r = 0.5 \quad \eta = -10$

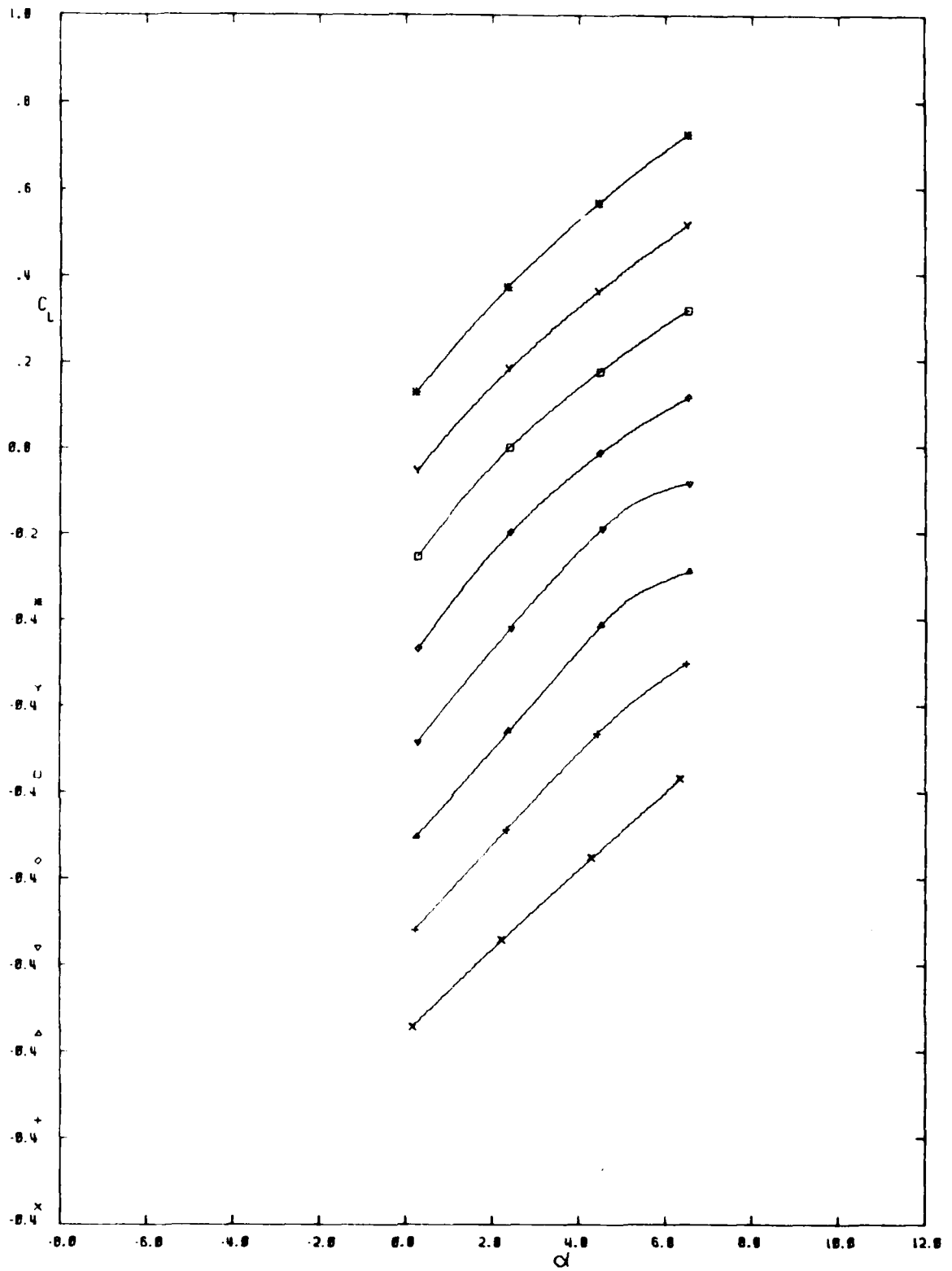

SYMBOL	M
x	.50
+	.70
△	.75
▽	.80
○	.84
□	.86
Y	.88
R	.90

FIGURE 6(1)
 VARIATION OF LIFT COEFFICIENT WITH INCIDENCE.
 $\eta_T = 0.5$ $\eta = -15$

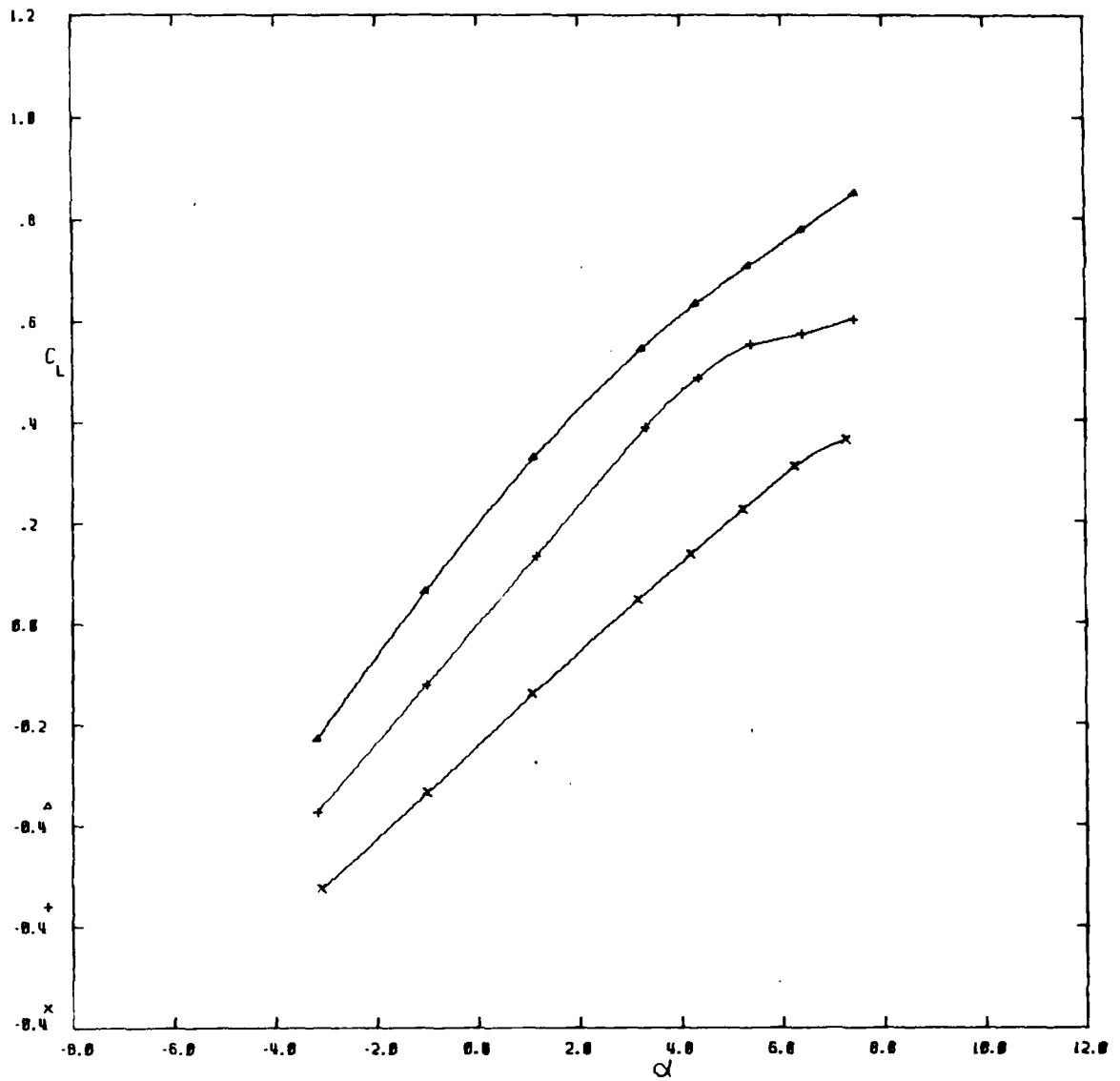

SYMBOL	M
x	.50
+	.60
^	.90

FIGURE 7
 VARIATION OF LIFT COEFFICIENT WITH INCIDENCE.
 TAIL PLANE OFF.

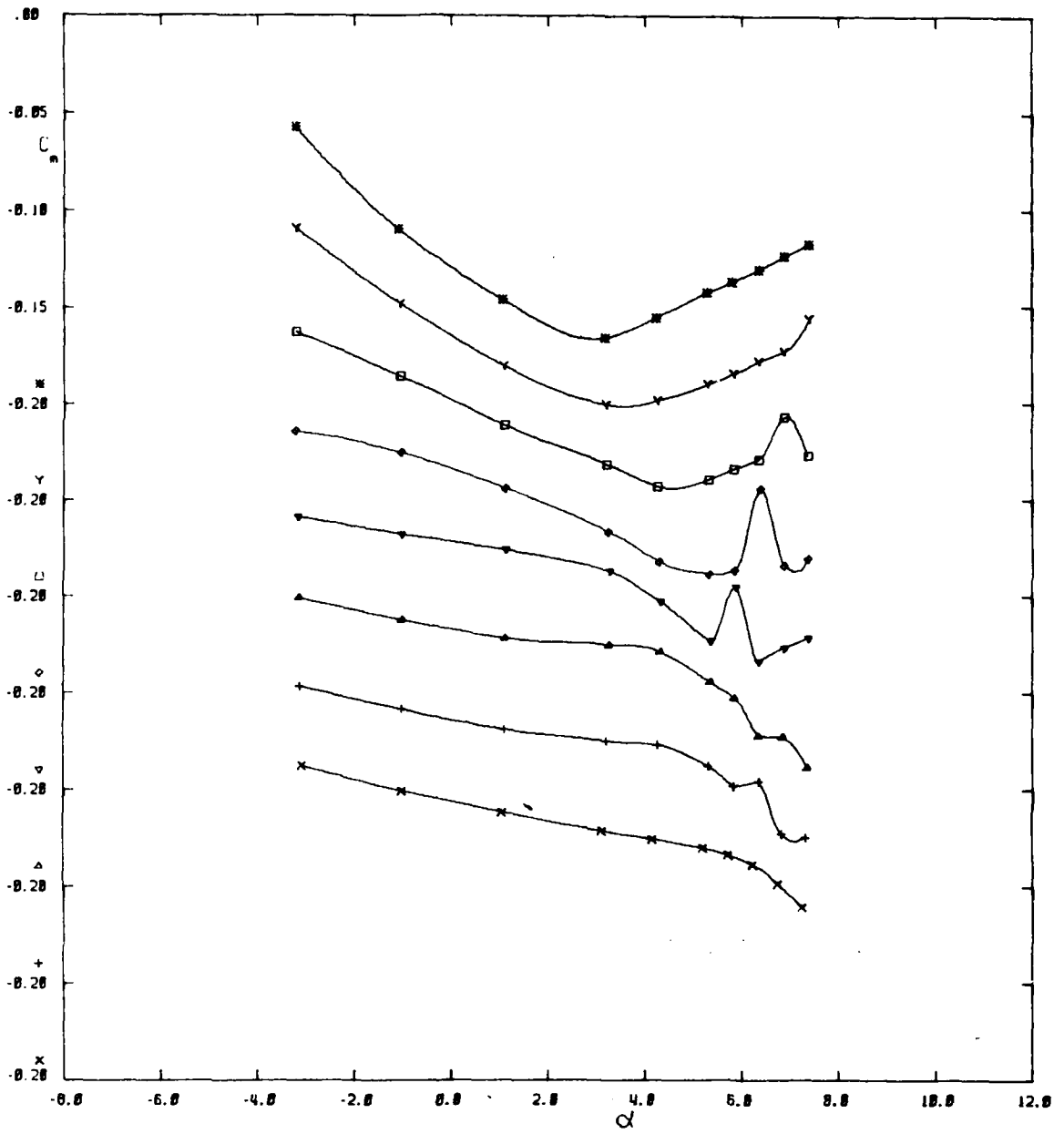

SYMBOL	M
x	.50
+	.70
△	.75
▽	.80
◇	.85
□	.86
Y	.88
*	.90

FIGURE 8(6)
 VARIATION OF PITCHING MOMENT COEFFICIENT WITH INCIDENCE.
 $\eta_r = 3.5 \quad \eta = 0$

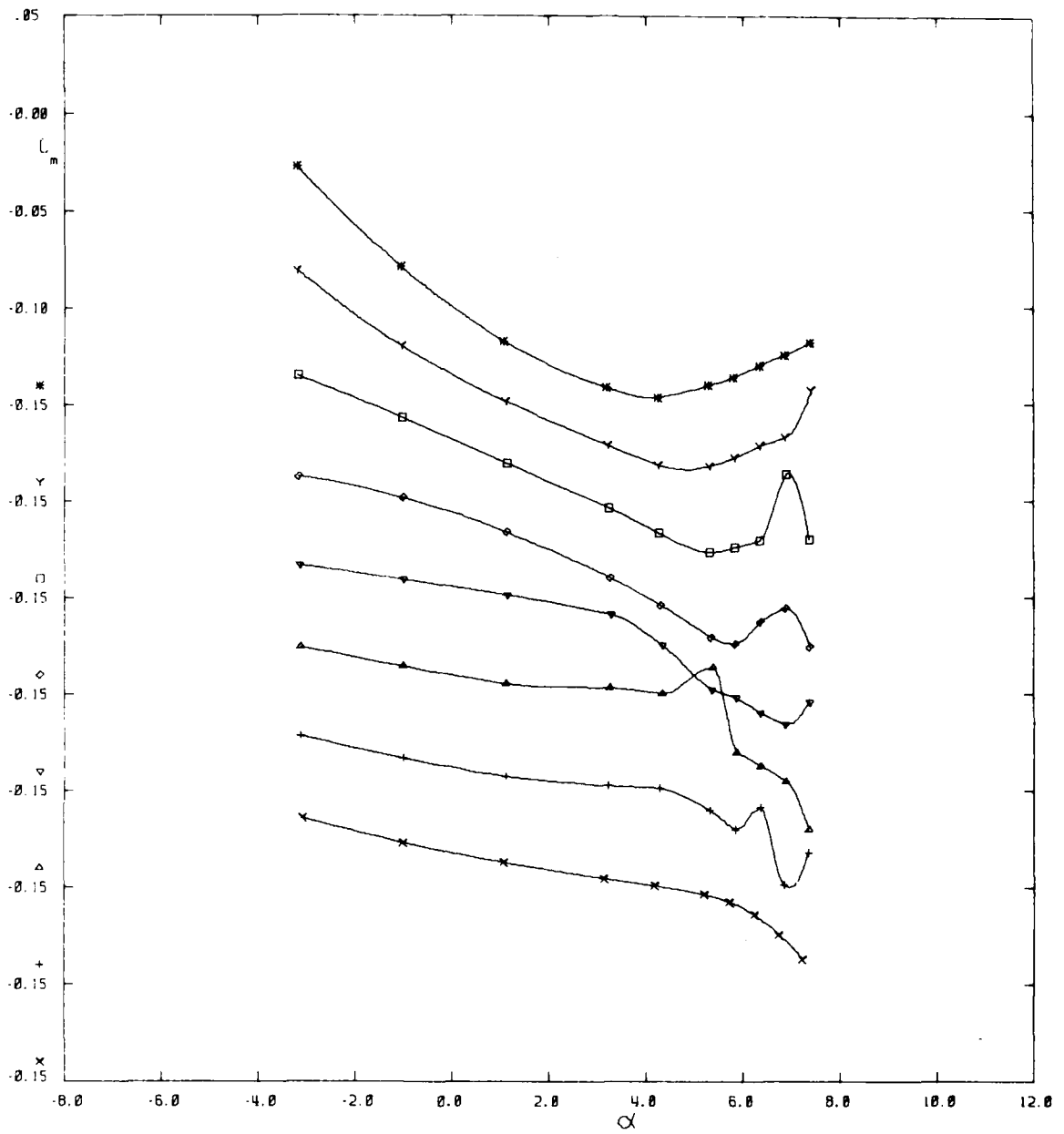

SYMBOL	M
x	.50
+	.70
△	.75
▽	.80
◇	.84
□	.86
Y	.88
*	.90

FIGURE 8(b)
 VARIATION OF PITCHING MOMENT COEFFICIENT WITH INCIDENCE.
 $\eta_{\tau} = 2.5$ $\eta = 0$

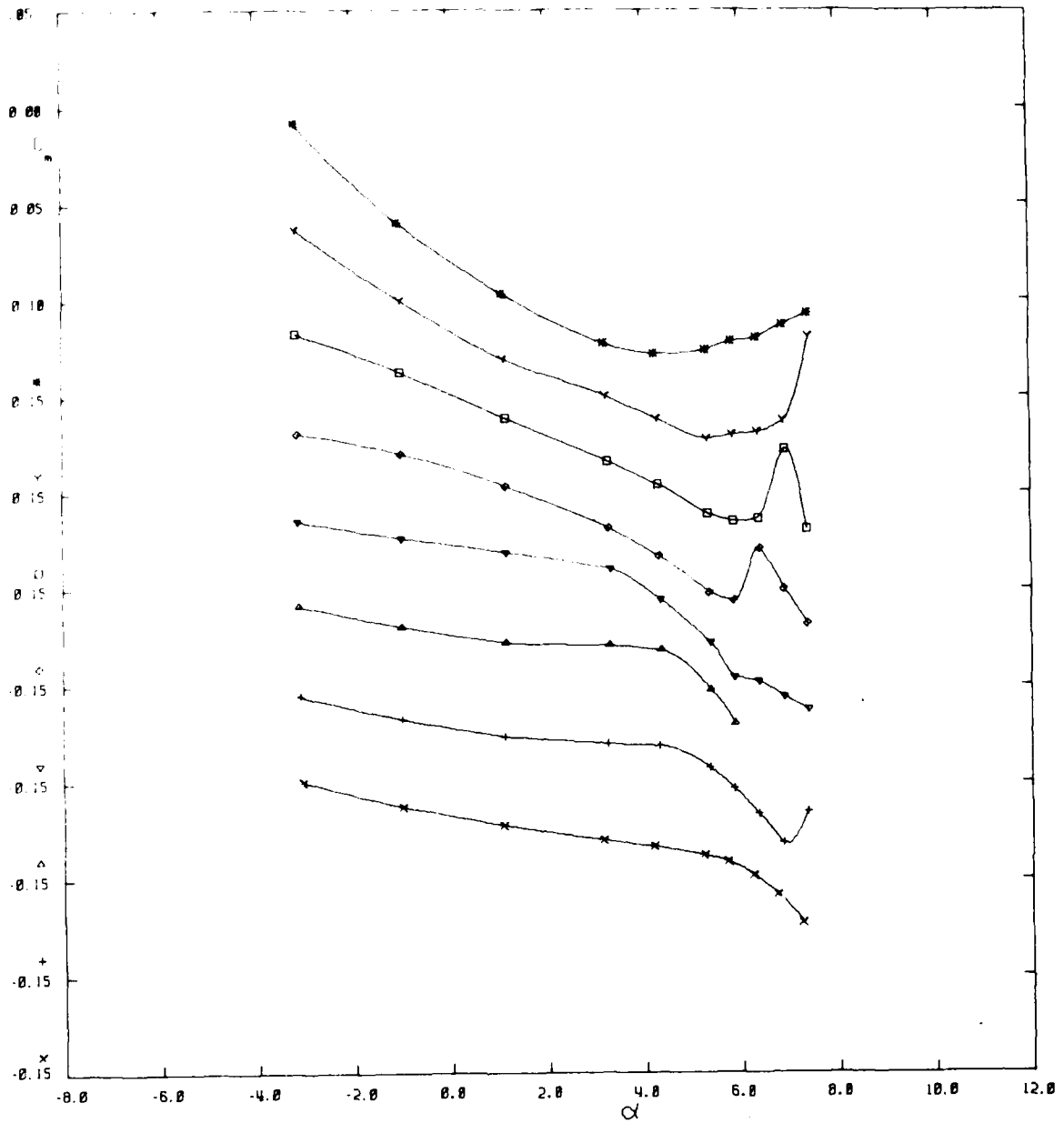

SYMBOL	M
x	.50
+	.70
△	.75
▽	.80
◇	.84
□	.86
Y	.88
※	.90

FIGURE 8(c)
 VARIATION OF PITCHING MOMENT COEFFICIENT WITH INCIDENCE.
 $\eta_r = 1.5 \quad \eta = 0$

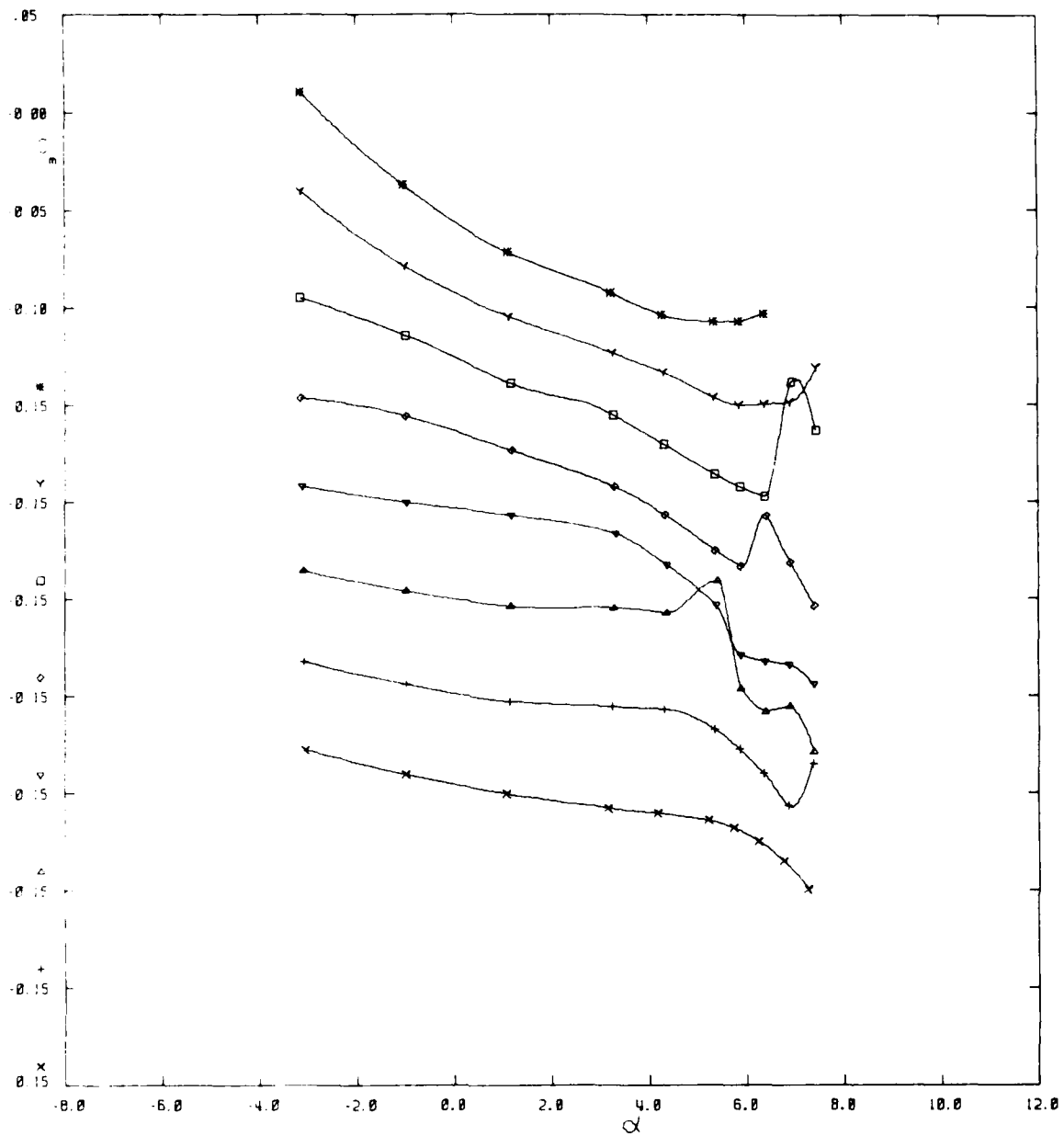

SYMBOL	M
x	.50
+	.70
Δ	.75
∇	.80
\diamond	.84
\square	.86
Y	.88
*	.90
\circ	.92
\times	.94

FIGURE 8(d)
 VARIATION OF PITCHING MOMENT COEFFICIENT WITH INCIDENCE.
 $\eta_r = 0.5$ $\eta = 0$

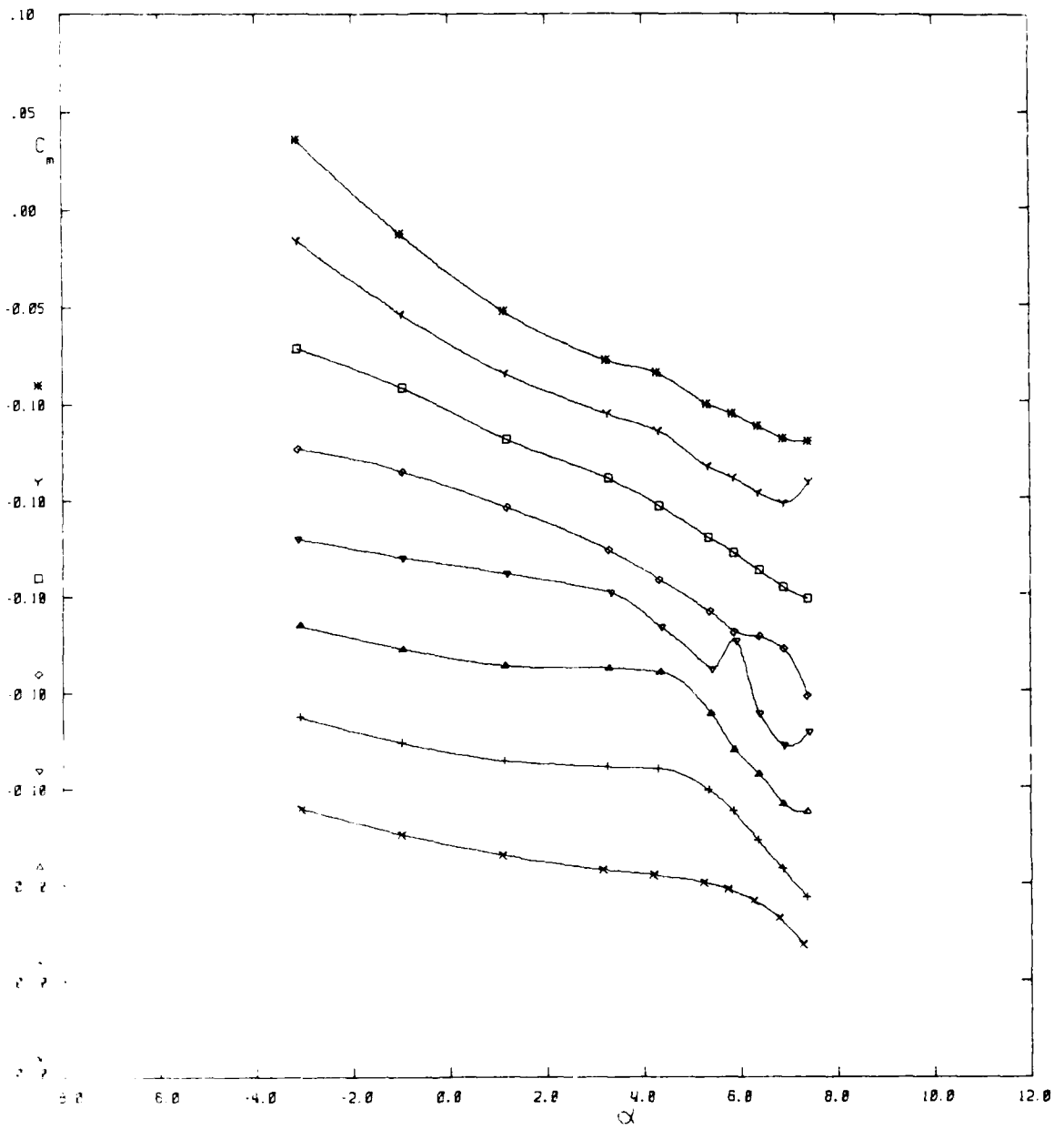

SYMBOL	M
x	.50
+	.70
△	.75
▽	.80
◇	.84
□	.86
∇	.88
○	.90

FIGURE 8(e)
 VARIATION OF PITCHING MOMENT COEFFICIENT WITH INCIDENCE.
 $\eta_r = -0.5 \quad \eta = 0$

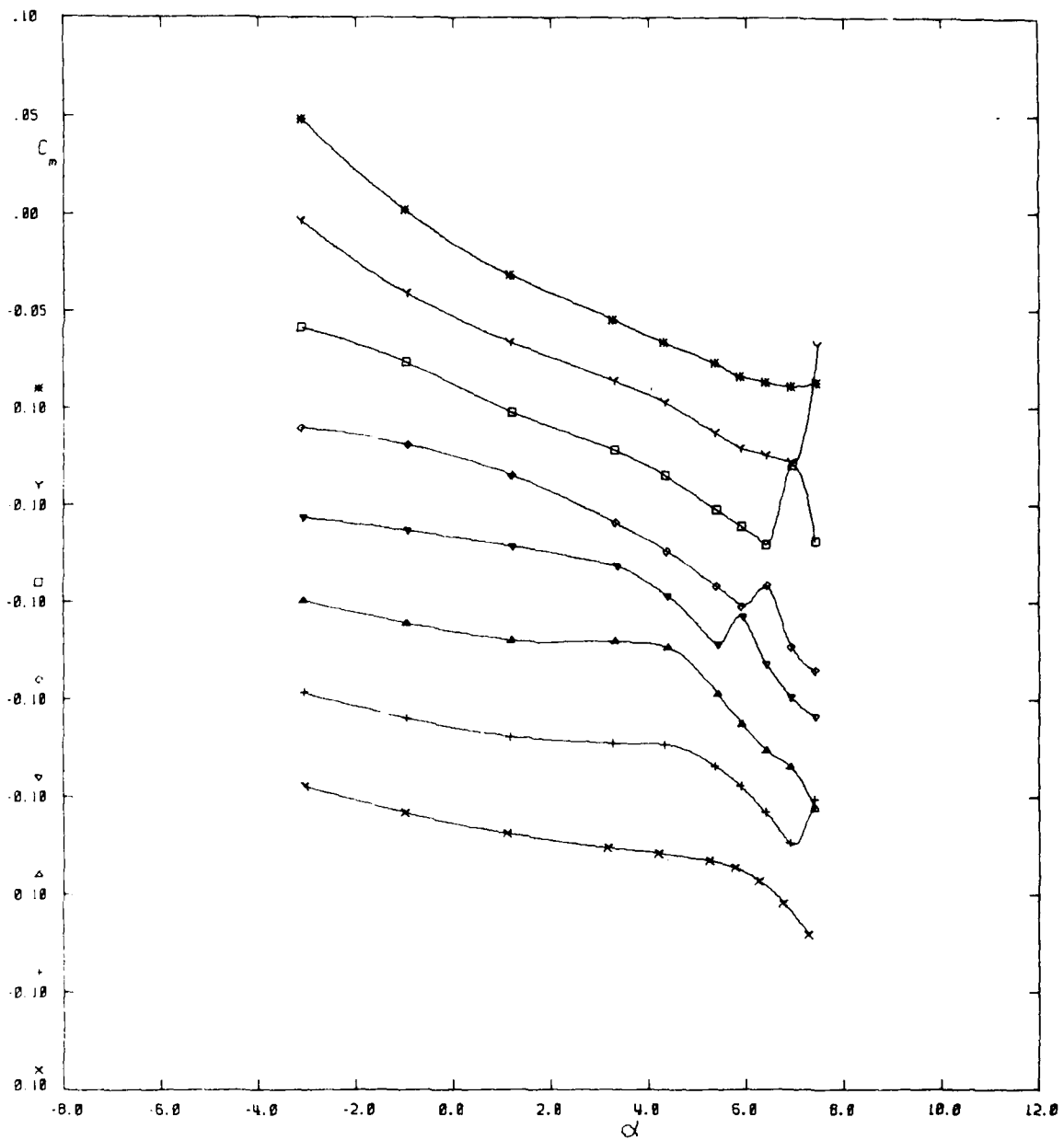

SYMBOL	M
x	.50
+	.70
△	.75
▽	.80
◇	.84
□	.86
Y	.88
*	.90

FIGURE 8(f)
 VARIATION OF PITCHING MOMENT COEFFICIENT WITH INCIDENCE.
 $\eta_{\tau} = -1.5$ $\eta = 0$

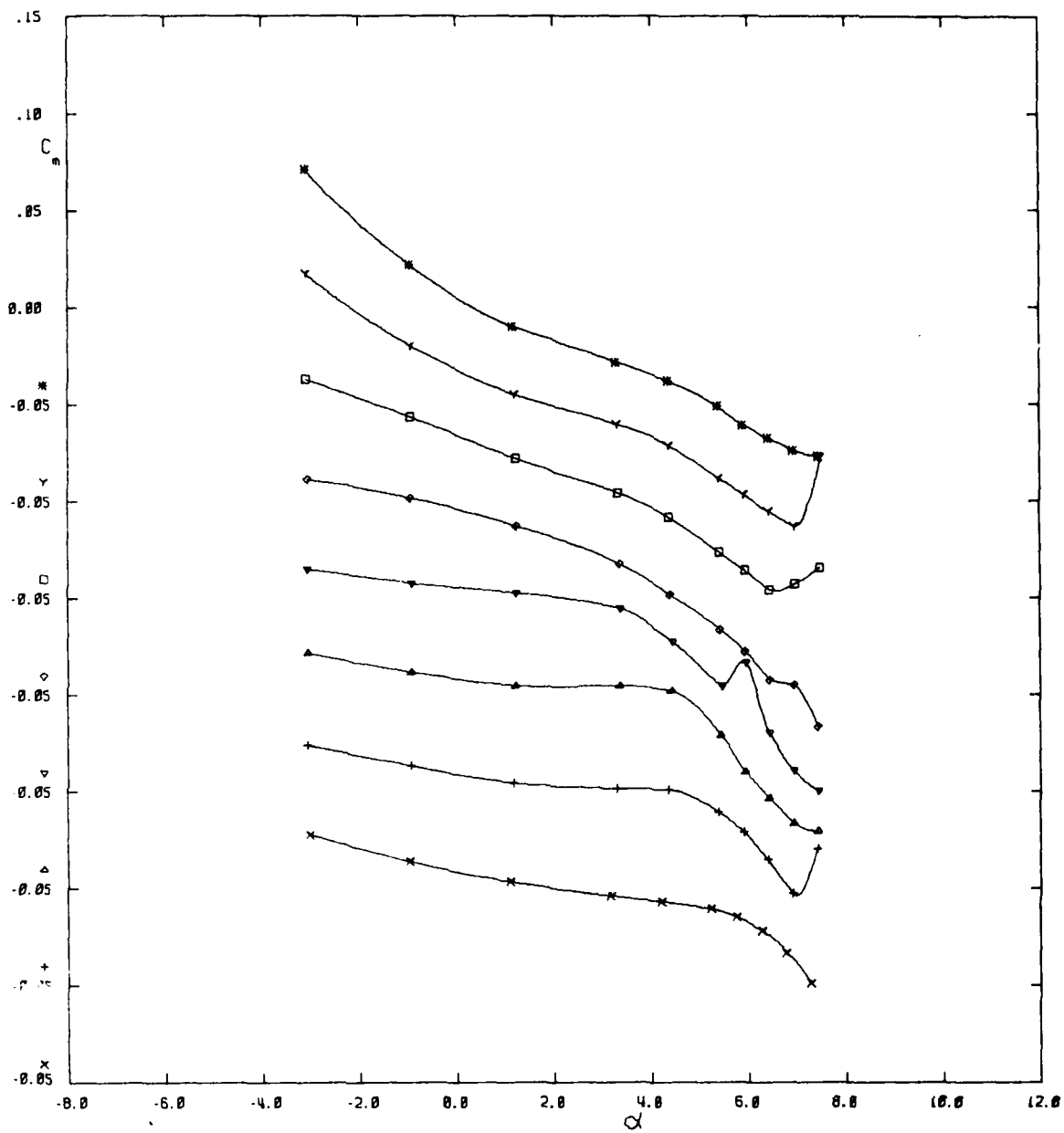

SYMBOL	M
x	.50
+	.70
△	.75
▽	.80
◇	.84
□	.86
Y	.88
*	.90

FIGURE 8(a)
 VARIATION OF PITCHING MOMENT COEFFICIENT WITH INCIDENCE.
 $\eta_T = -2.5$ $\eta = 0$

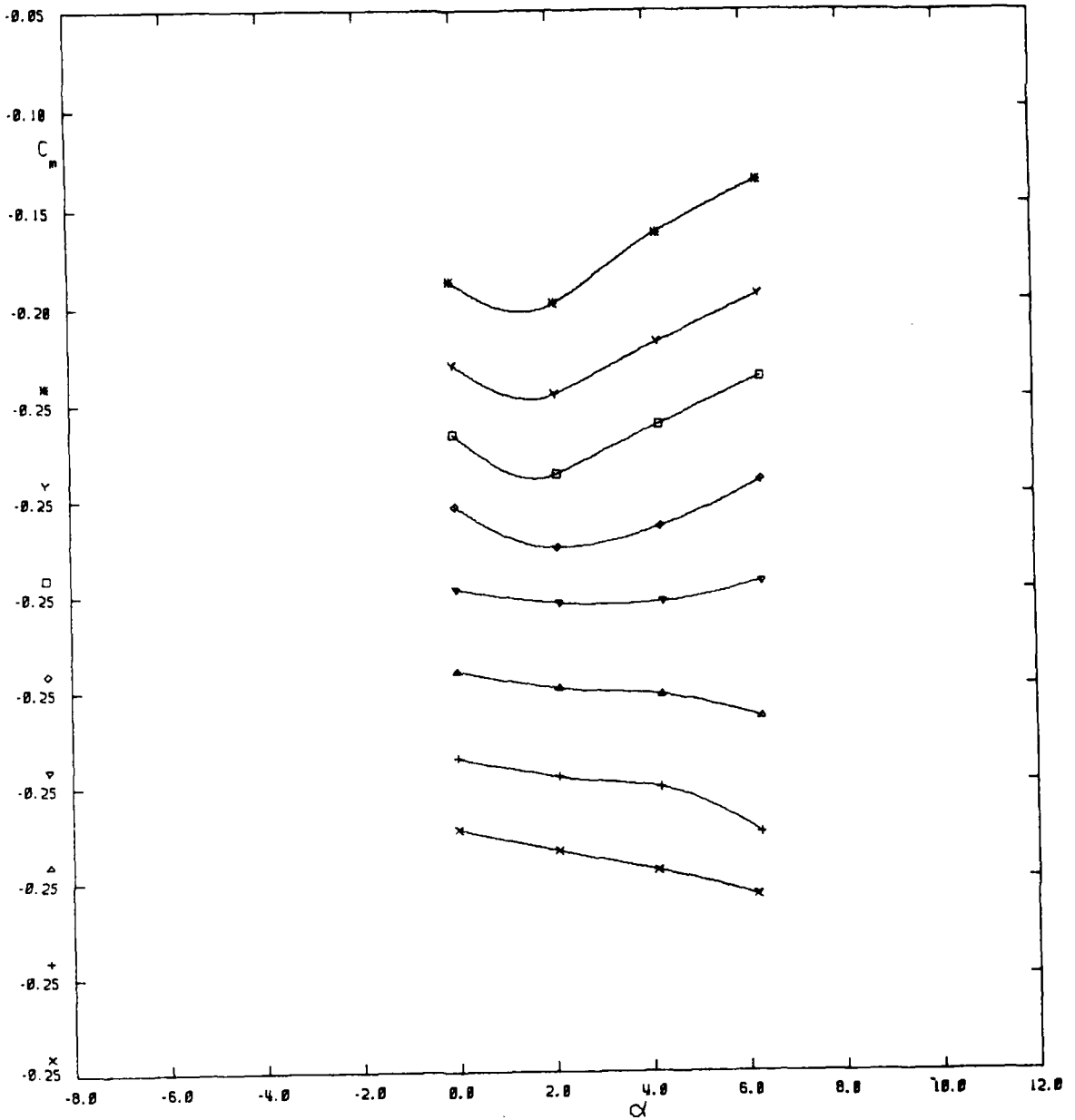

SYMBOL	M
X	.50
+	.70
^	.75
v	.80
o	.84
□	.86
Y	.88
*	.90

FIGURE 9(a)
 VARIATION OF PITCHING MOMENT COEFFICIENT WITH INCIDENCE.
 $\eta_r = 0.5$ $\eta = 10$

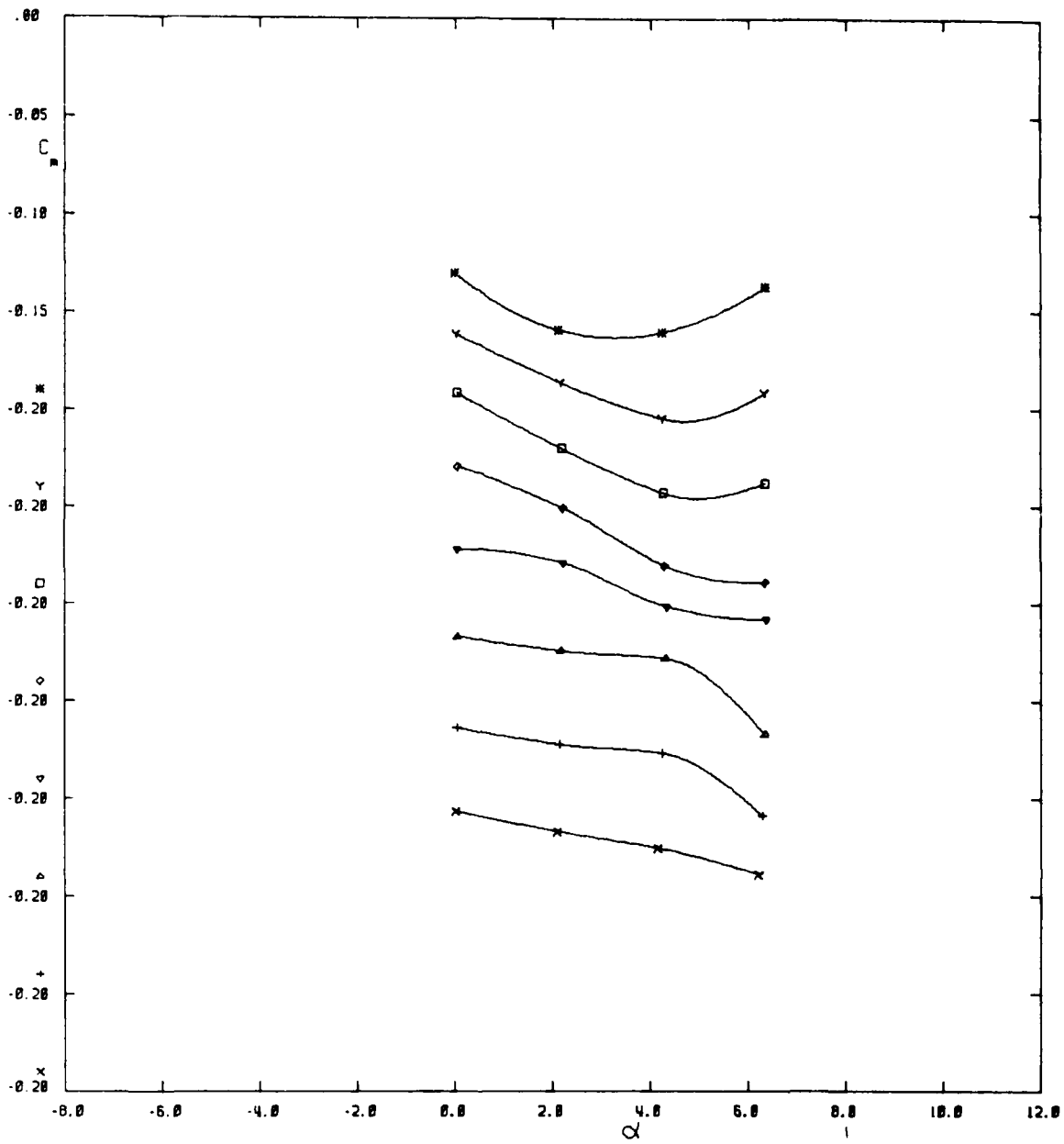

SYMBOL	M
x	.50
+	.70
△	.75
▽	.80
◇	.84
□	.86
Y	.88
*	.90

FIGURE 9(b)
 VARIATION OF PITCHING MOMENT COEFFICIENT WITH INCIDENCE.
 $\eta_T = 0.5$ $\eta = 5$

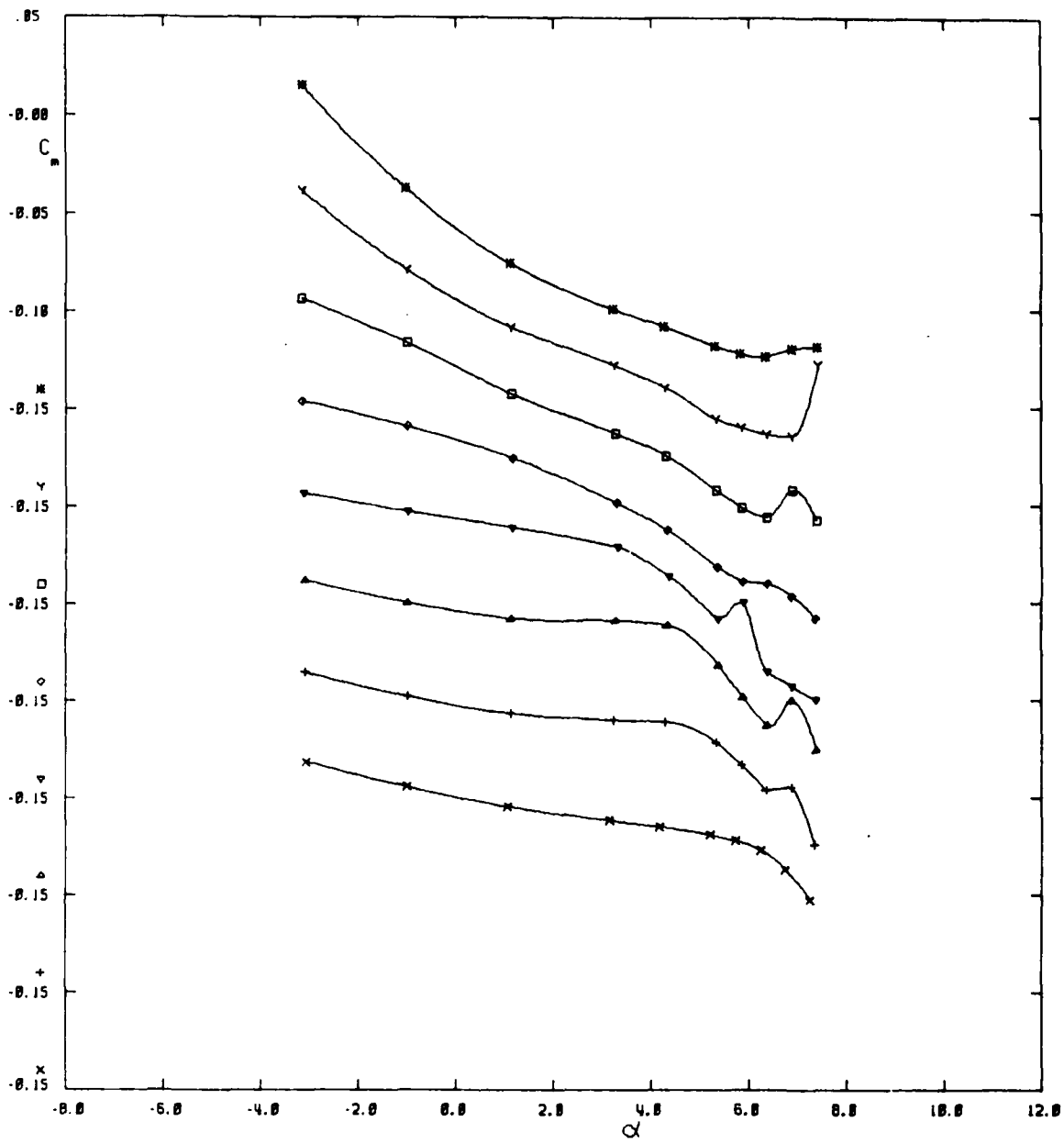

SYMBOL	M
x	.50
+	.70
△	.75
▽	.80
○	.84
□	.86
Y	.88
■	.90

FIGURE 9(c)
 VARIATION OF PITCHING MOMENT COEFFICIENT WITH INCIDENCE.
 $\eta_T = 0.5$ $\eta = 0$

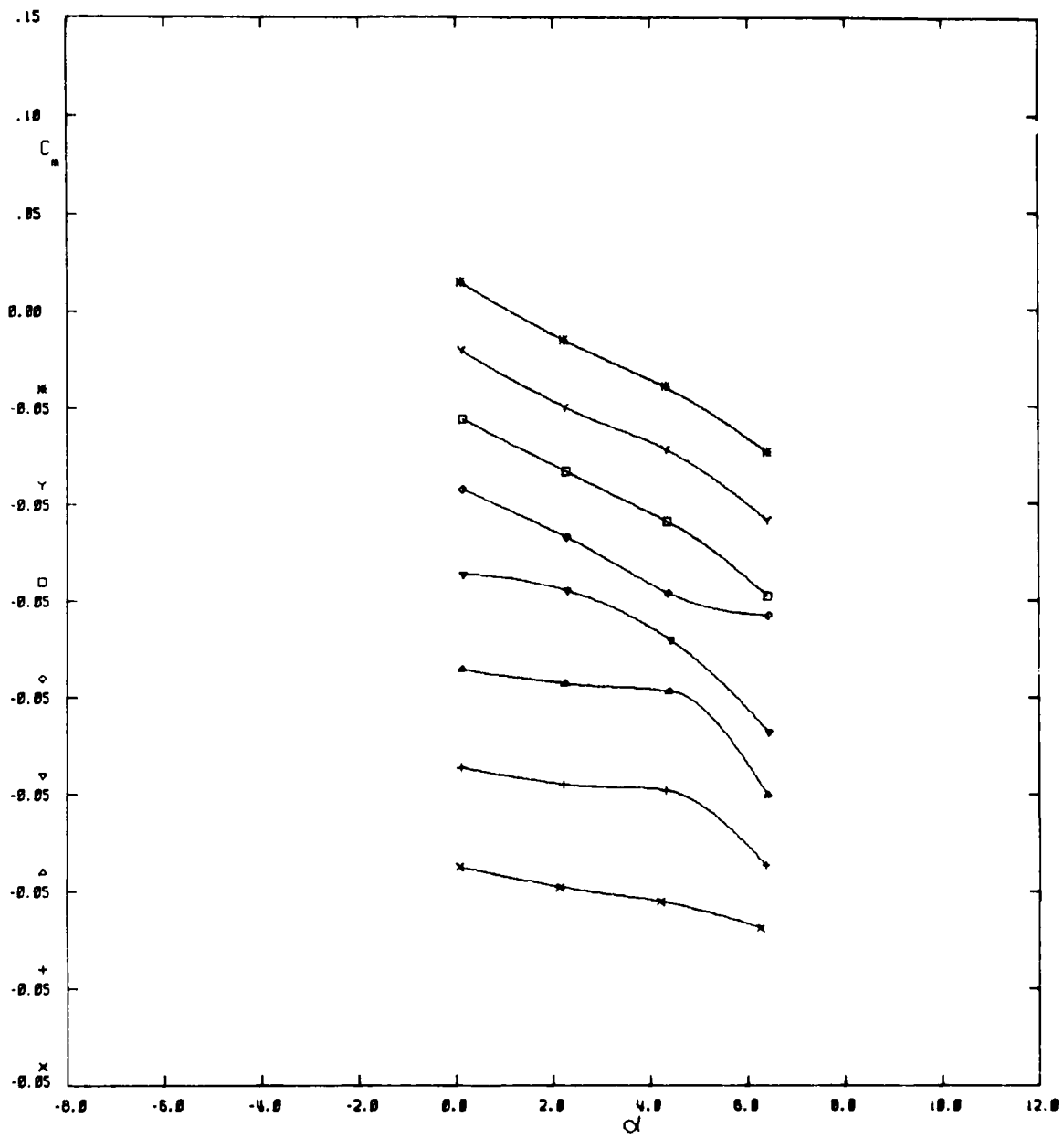

SYMBOL	M
x	.50
+	.70
△	.75
▽	.80
◇	.84
□	.86
Y	.88
*	.90
•	.92
◊	.94
◊	.96
◊	.98

FIGURE 9(d)
 VARIATION OF PITCHING MOMENT COEFFICIENT WITH INCIDENCE.
 $\eta_r = 0.5$ $\eta = .5$

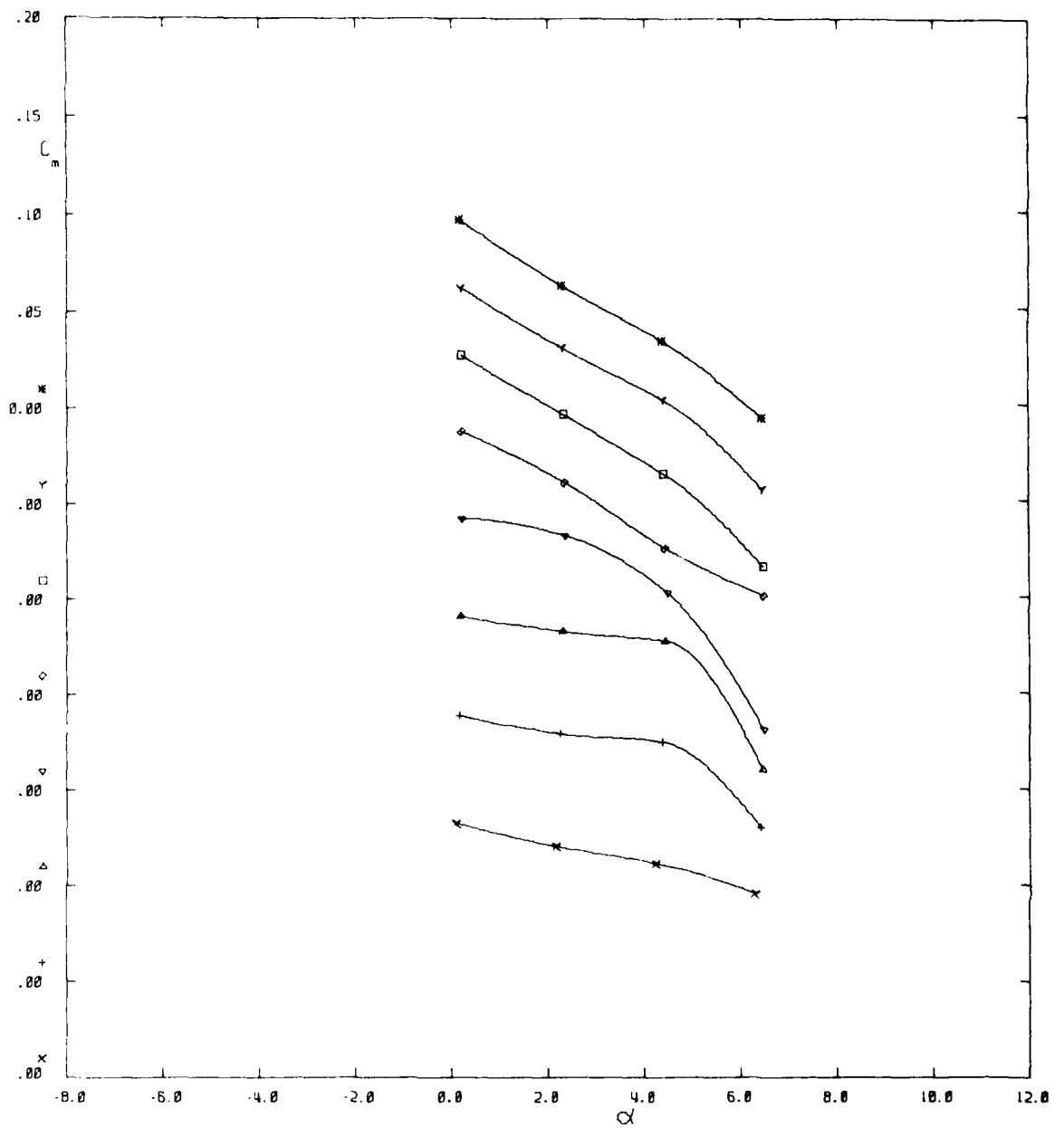

SYMBOL	M
x	.50
+	.70
△	.75
▽	.80
◇	.84
□	.86
Y	.88
*	.90

FIGURE 9(e)
 VARIATION OF PITCHING MOMENT COEFFICIENT WITH INCIDENCE.
 $\eta_r = 0.5$ $\eta = -10$

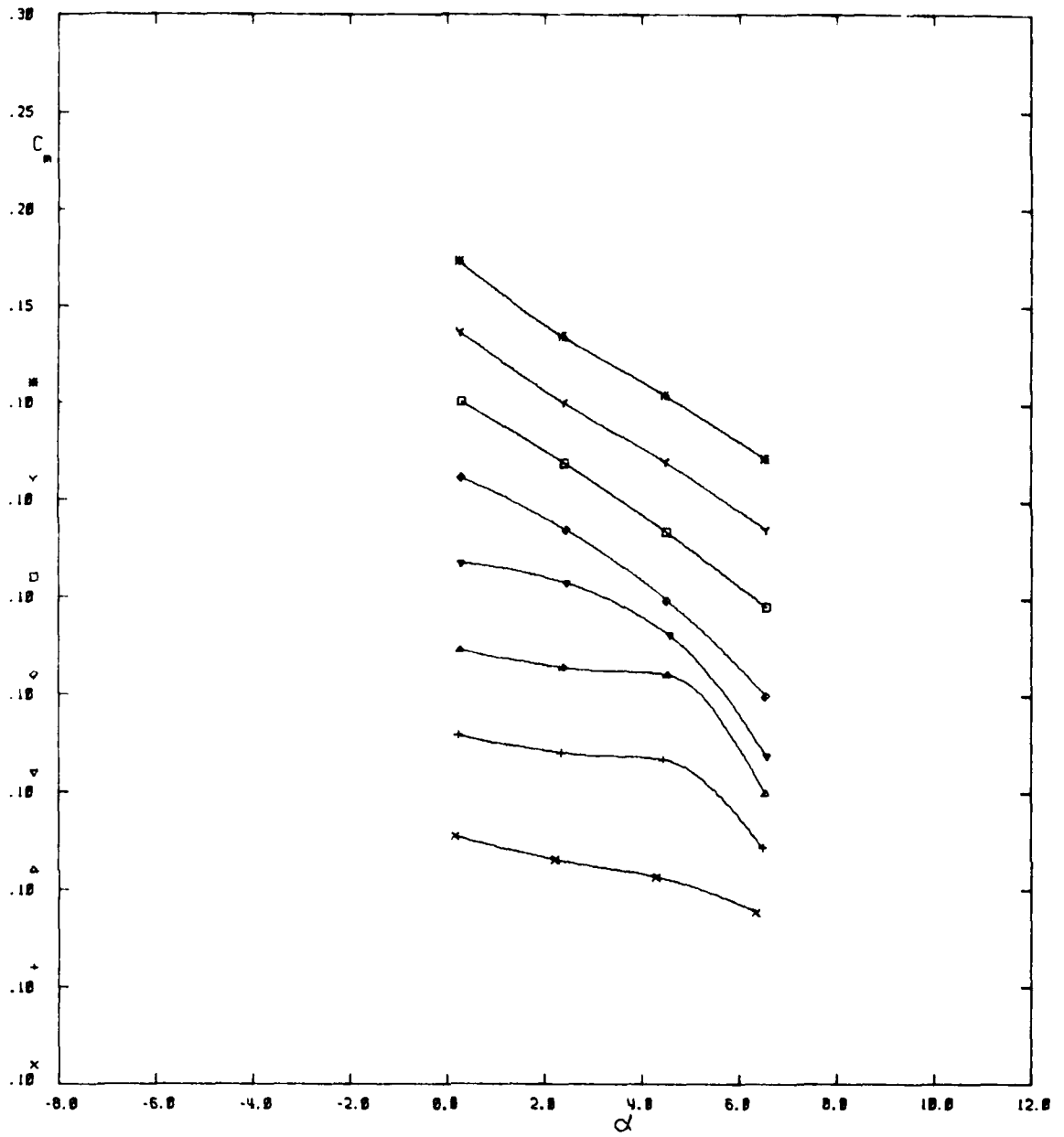

SYMBOL	M
x	.50
+	.70
△	.75
▽	.80
◇	.84
□	.86
Y	.88
■	.90

FIGURE 9(?)
 VARIATION OF PITCHING MOMENT COEFFICIENT WITH INCIDENCE.
 $\eta_T = 0.5$ $\eta = -15$

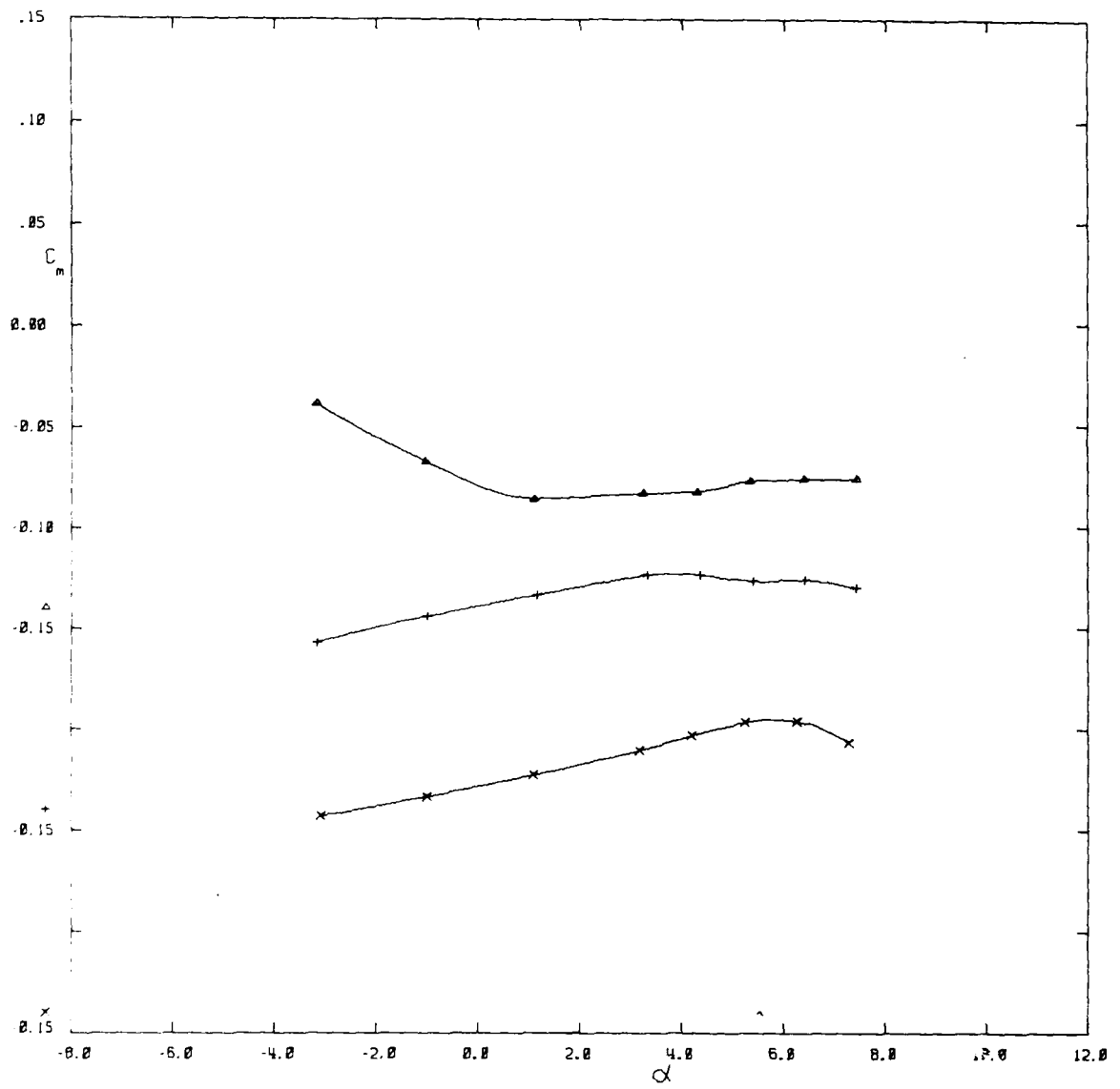

SYMBOL M
 x .50
 + .80
 triangle .90

FIGURE 10
 VARIATION OF PITCHING MOMENT COEFFICIENT WITH INCIDENCE.
 TAIL PLANE OFF.

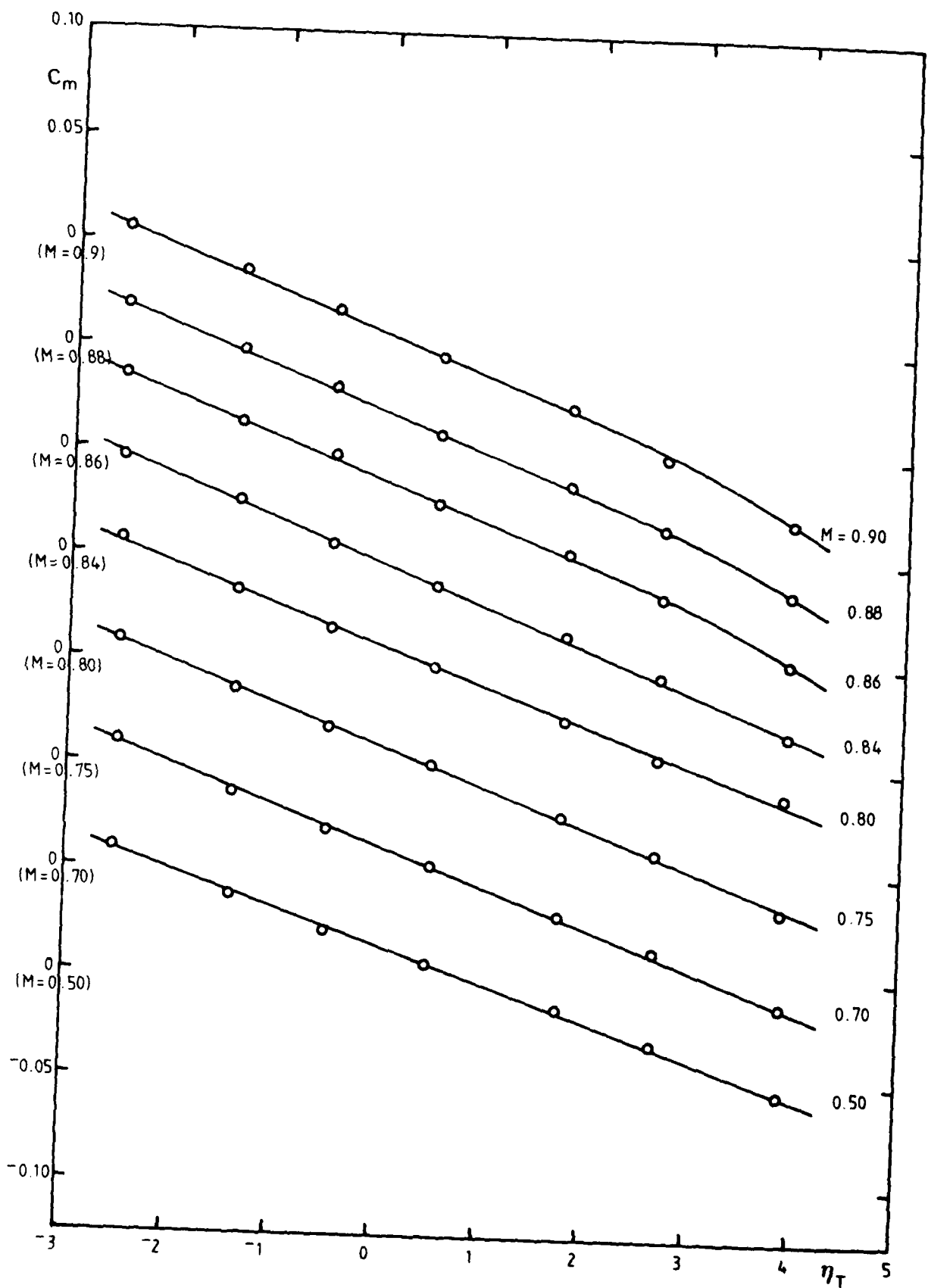

FIG. 11(a) VARIATION OF PITCHING MOMENT COEFFICIENT WITH TAILPLANE ANGLE
 $(\alpha = 0^\circ; \eta = 0^\circ)$

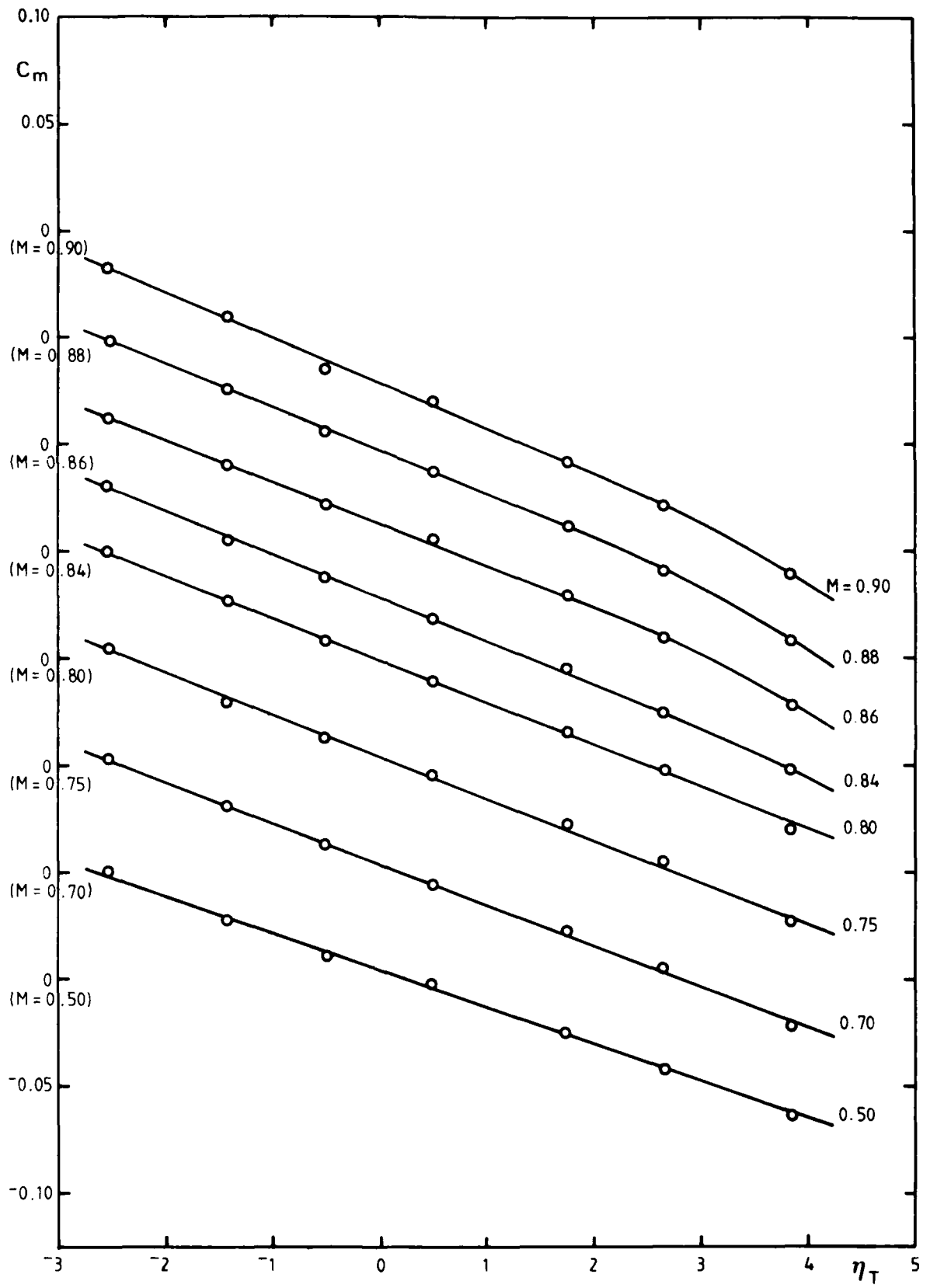

FIG. 11(b) VARIATION OF PITCHING WITH TAILPLANE ANGLE $\alpha = 2^\circ$; $\eta = 0^\circ$

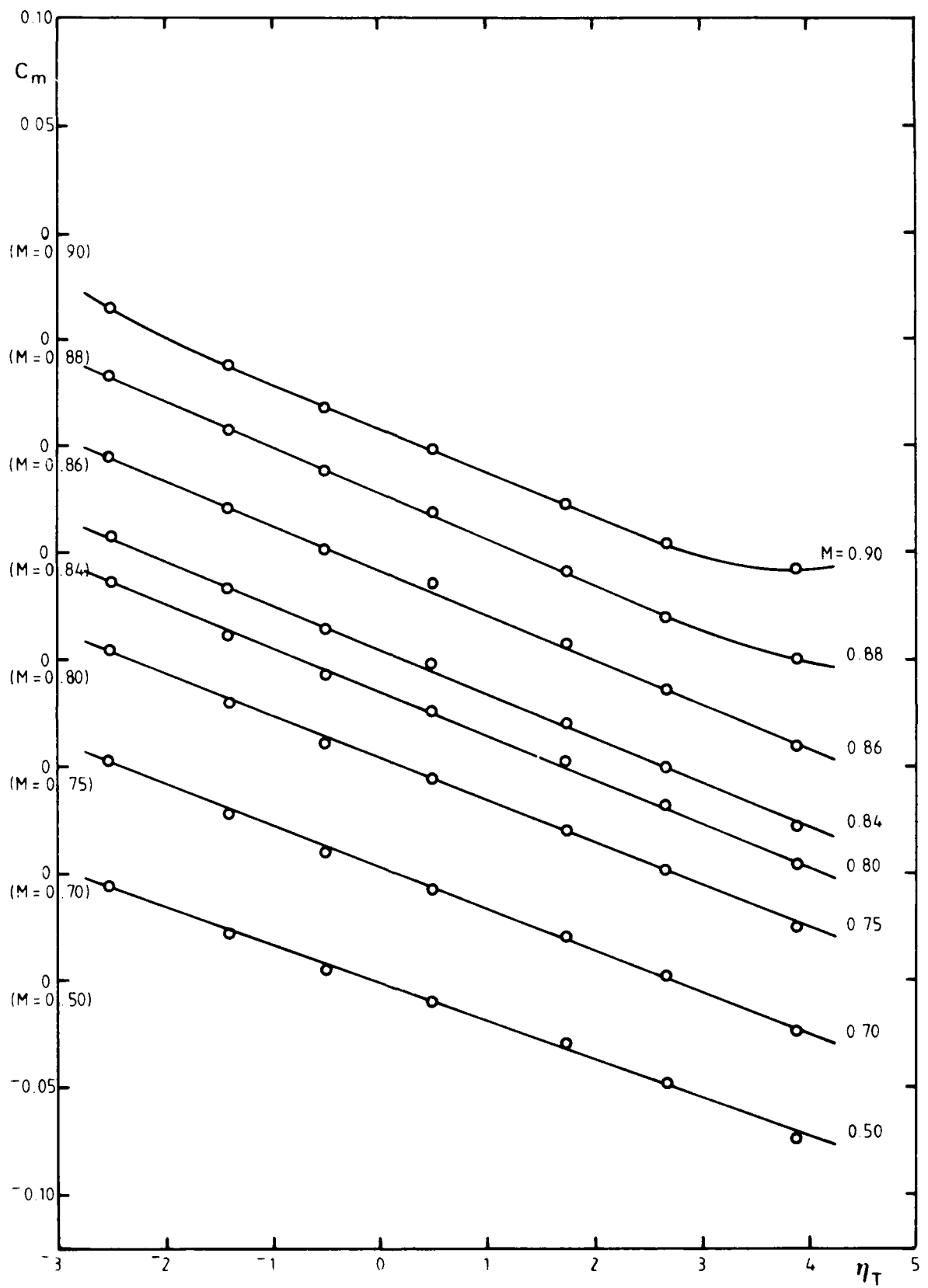

FIG. 11(c) VARIATION OF PITCHING MOMENT COEFFICIENT WITH TAILPLANE ANGLE
 $\alpha = 4^\circ; \eta = 0^\circ$

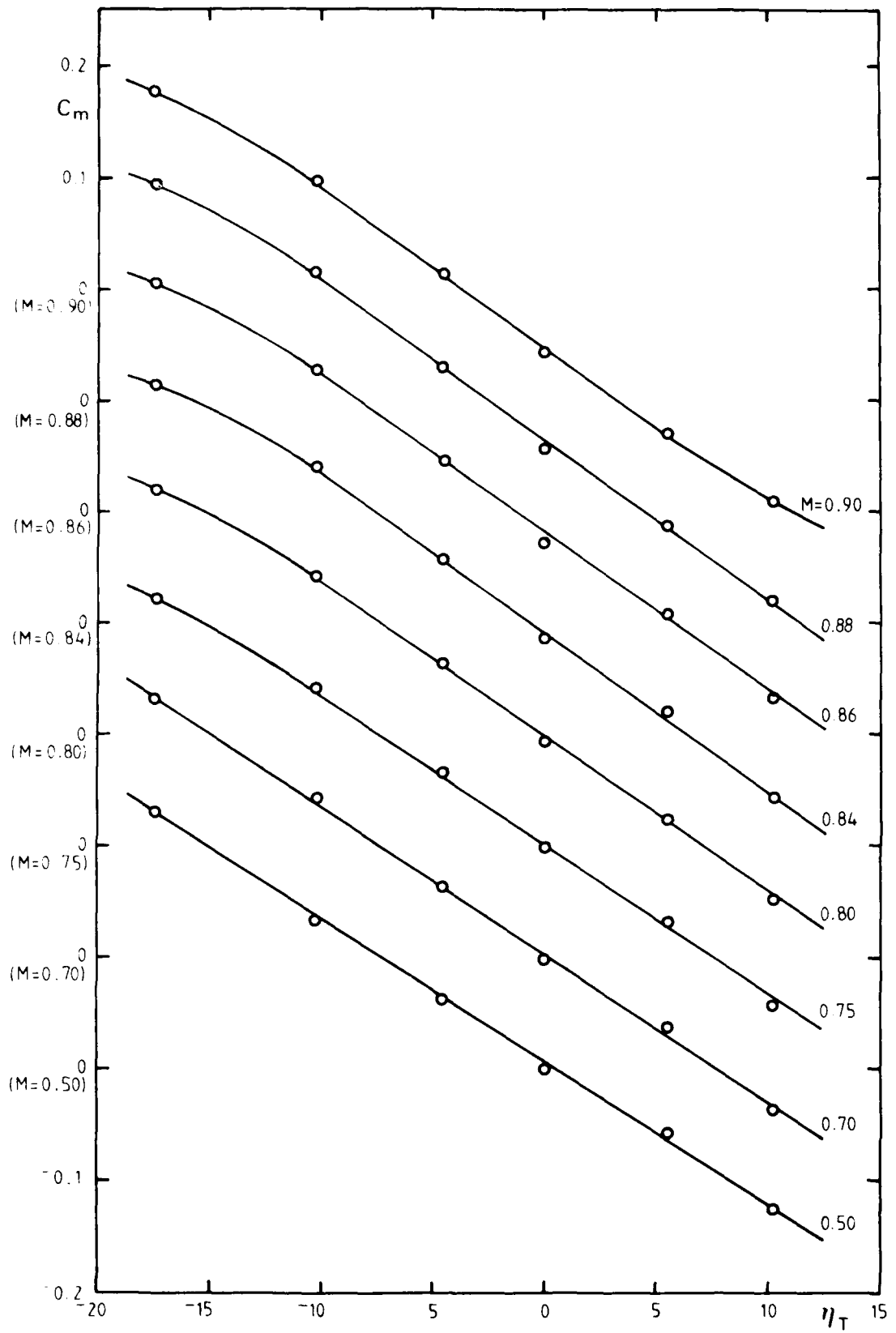

FIG. 12(a) VARIATION OF PITCHING MOMENT COEFFICIENT WITH ELEVATOR ANGLE
 $\alpha = 0^\circ$; $\eta_T = \frac{1}{2}^\circ$

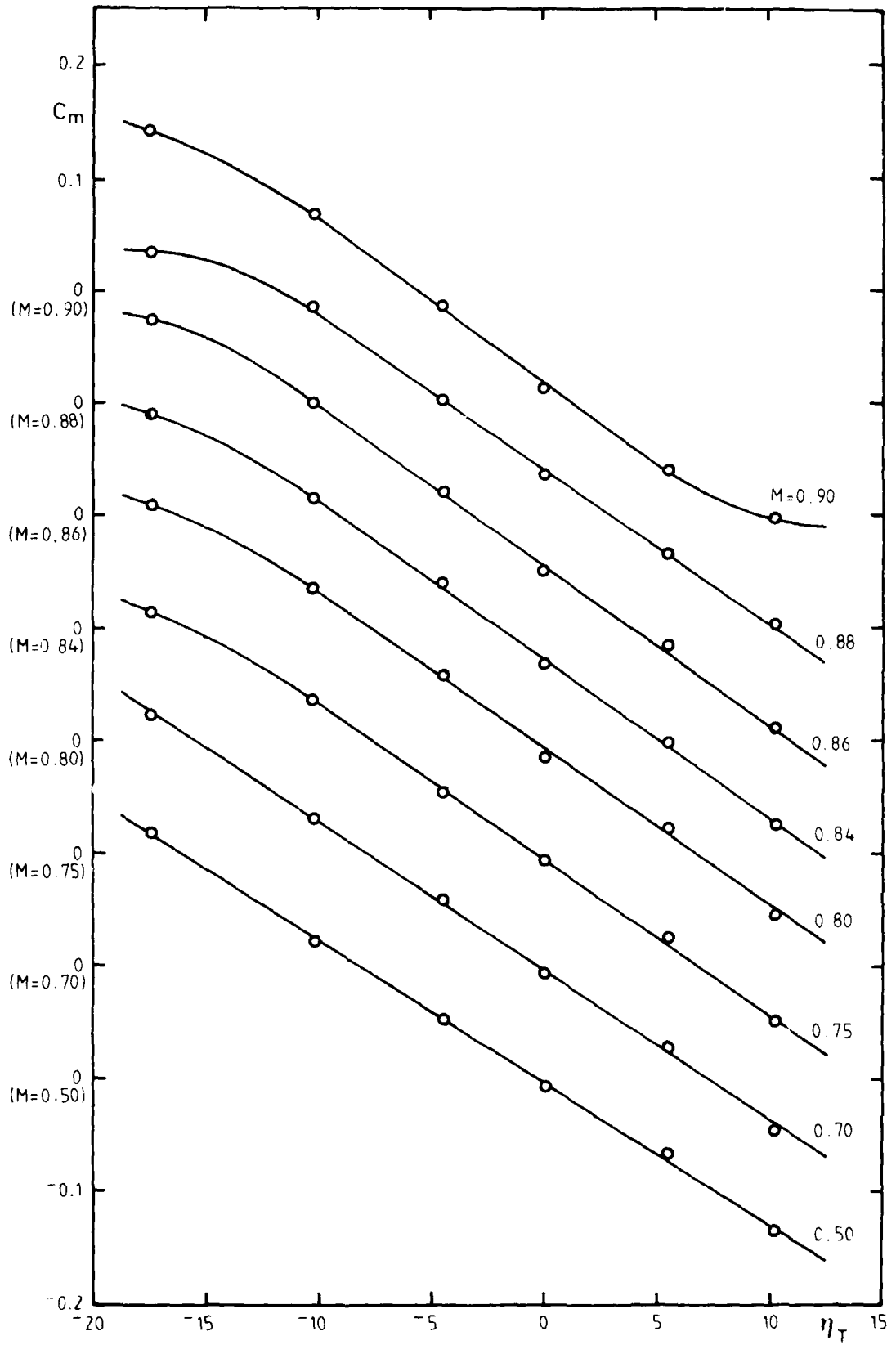

FIG. 12(b) VARIATION OF PITCHING MOMENT COEFFICIENT WITH ELEVATOR ANGLE
 $\alpha = 2^\circ; \eta_T = \frac{1}{2}^\circ$

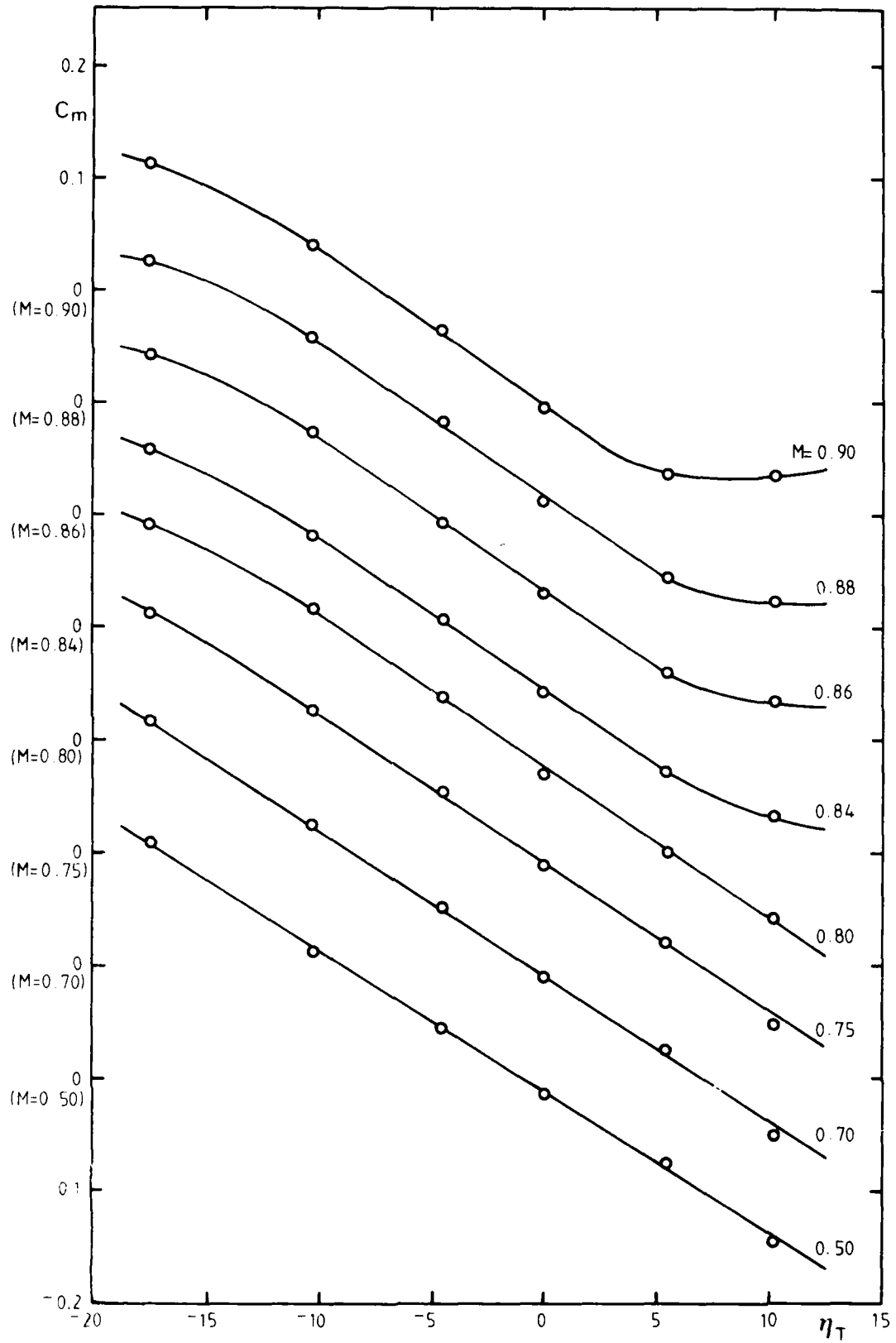

FIG. 12(c) VARIATION OF PITCHING MOMENT COEFFICIENT WITH ELEVATOR ANGLE
 $\alpha = 0^\circ; \eta_T = \frac{1}{2}^\circ$

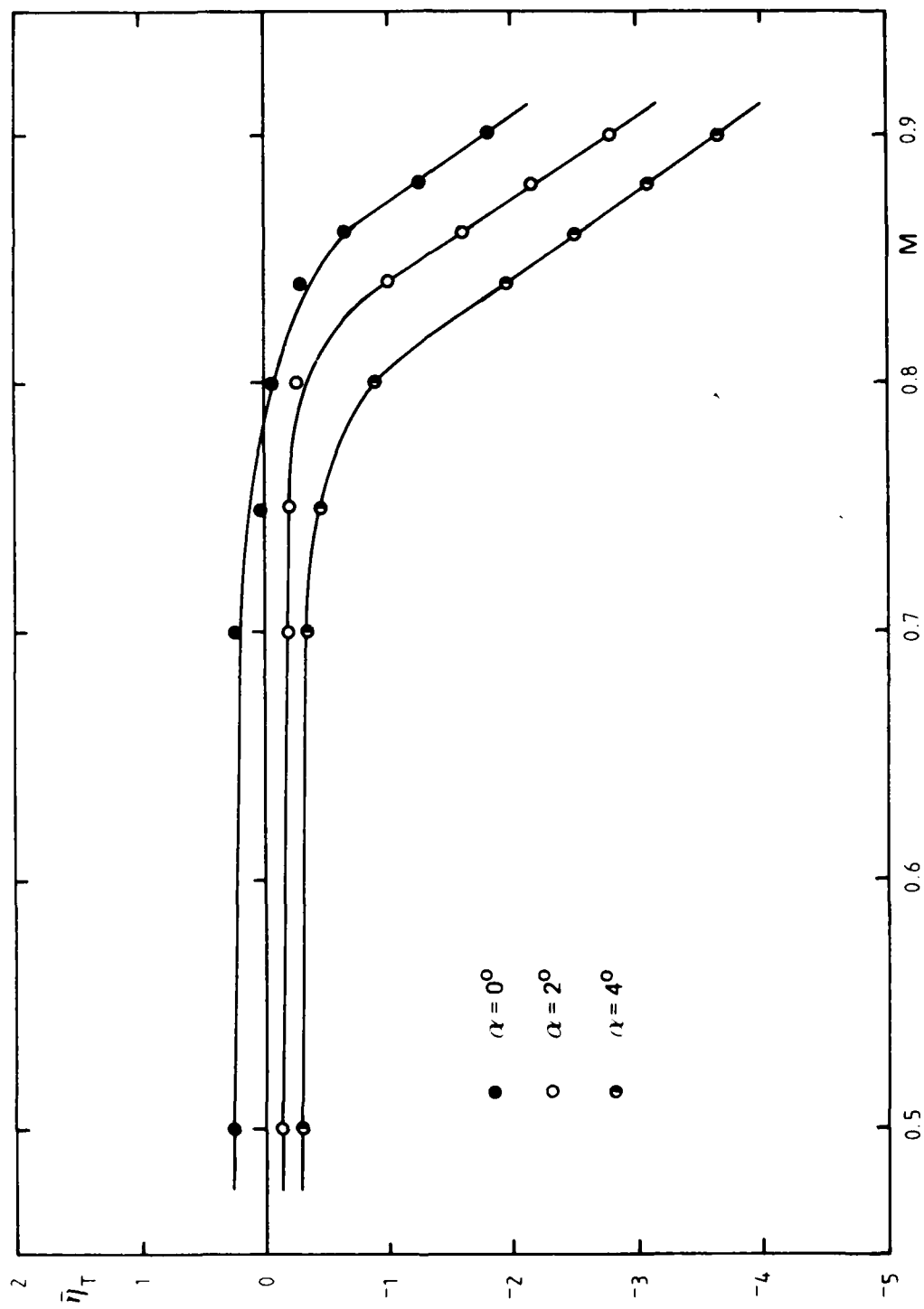

FIG. 13 VARIATION OF TAILPLANE ANGLE TO TRIM WITH MACH NUMBER $\eta = 0^\circ$

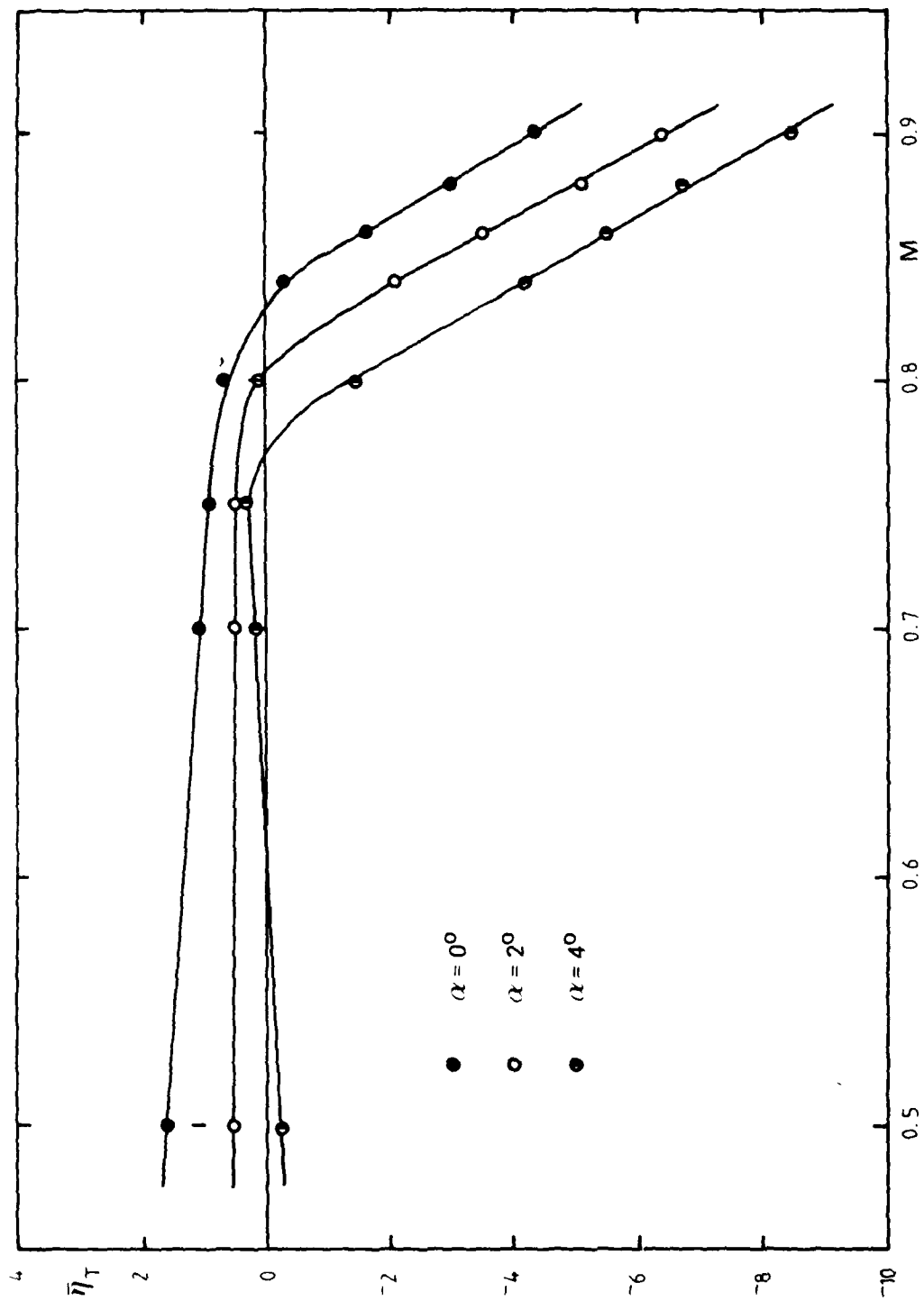

FIG. 14 VARIATION OF ELEVATOR ANGLE TO TRIM WITH MACH NUMBER $\eta_T = \frac{1}{2}^\circ$

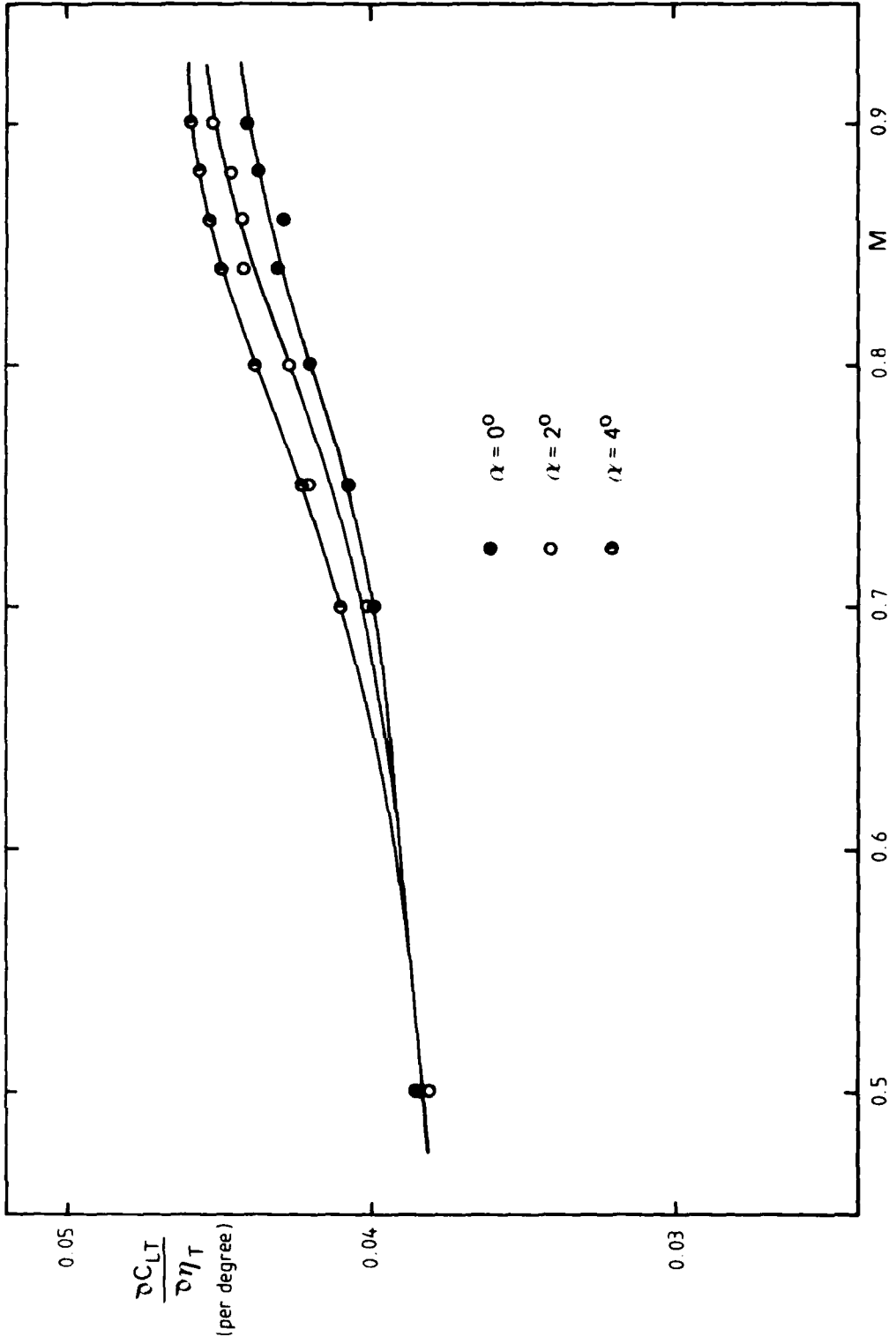

FIG. 15 VARIATION OF TAILPLANE EFFECTIVENESS WITH MACH NUMBER $\eta = 0^\circ$

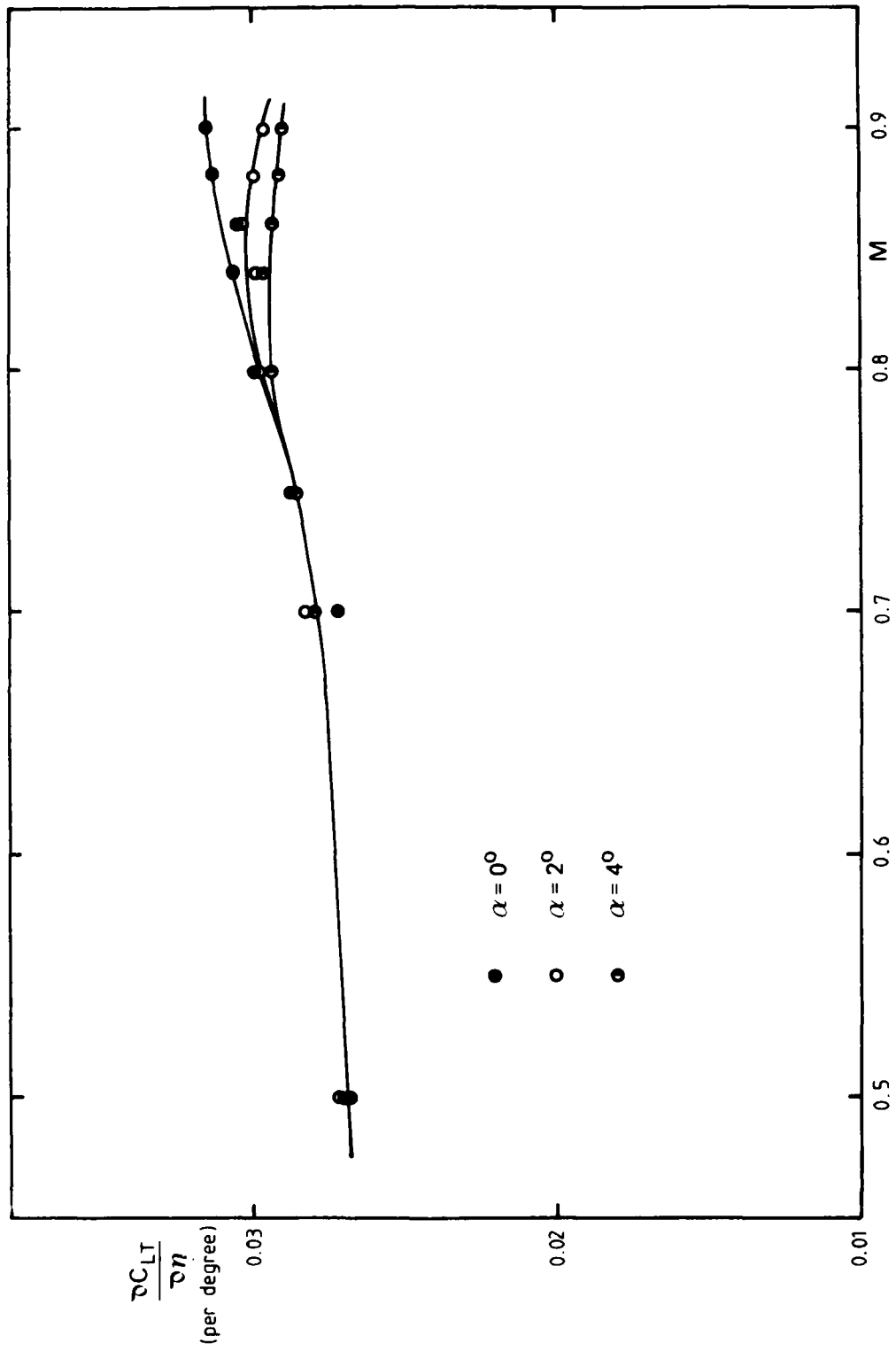

FIG. 16 VARIATION OF ELEVATOR EFFECTIVENESS WITH MACH NUMBER $\eta_T = \frac{1}{2}^\circ$

DISTRIBUTION

Copy No.

AUSTRALIA

Department of Defence

Central Office

Chief Defence Scientist	1
Deputy Chief Defence Scientist	2
Superintendent, Science and Technology Programs	3
Australian Defence Scientific and Technical Representative (UK)	—
Counsellor, Defence Science (USA)	—
Joint Intelligence Organisation	4
Defence Library	5
Document Exchange Centre, D.I.S.B.	6-23

Aeronautical Research Laboratories

Chief Superintendent	24
Library	25
Superintendent — Aerodynamics Division	26
Divisional File — Aerodynamics	27
Author: B. D. Fairlie	28
Transonic Aerodynamics Group	29-33

Materials Research Laboratories

Library	34
---------	----

Defence Research Centre, Salisbury

Library	35
---------	----

Central Studies Establishment

Information Centre	36
--------------------	----

Engineering Development Establishment

Library	37
---------	----

RAN Research Laboratory

Library	38
---------	----

Navy Office

Naval Scientific Adviser	39
--------------------------	----

Army Office

Army Scientific Adviser	40
Royal Military College Library	41

Air Force Office

Aircraft Research and Development Unit, Scientific Flight Group	42
Air Force Scientific Adviser	43
Technical Division Library	44
DGAIRENG	45
HQ Support Command (SENGSO)	46
RAAF Academy, Point Cook	47

**Department of Productivity
Government Aircraft Factories**

Manager	48
Library	49
Mr P. Hughes	50
Mr D. Pilkington	51
Spares	52-62

DATE
FILMED
— 8