

AD-A098 339

AERONAUTICAL RESEARCH LABS MELBOURNE (AUSTRALIA)
STATIC BENDING TESTS ON GRP-VINYL FOAM SANDWICH BEAMS.(U)
OCT 80 P H TOWNSHEND
ARL/STRUC-TM-324

F/6 11/9

UNCLASSIFIED

NL

1 2 3
4 5 6 7 8 9 10 11 12
13

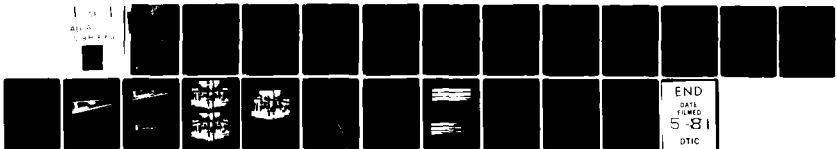

END
DATE
FILMED
5-81
DTIC

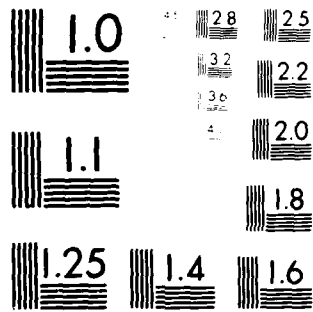

MICROCOPY RESOLUTION TEST CHART
 NATIONAL BUREAU OF STANDARDS-1963-A

UNCLASSIFIED
LEVEL II

ARL-STRUC-TECH-MEMO-324

AR-002-243



12

AD A 098 339

**DEPARTMENT OF DEFENCE
DEFENCE SCIENCE AND TECHNOLOGY ORGANISATION
AERONAUTICAL RESEARCH LABORATORIES**

MELBOURNE, VICTORIA

Structures Technical Memorandum 324

STATIC BENDING TESTS ON GRP-VINYL FOAM SANDWICH BEAMS

P.H. TOWNSHEND

**DTIC
SELECTE
APR 30 1981**

THE UNITED STATES NATIONAL
TECHNICAL INFORMATION SERVICE
IS AUTHORISED TO
REPRODUCE AND SELL THIS REPORT

Approved for Public Release.



© COMMONWEALTH OF AUSTRALIA 1980

OCTOBER 1980

COPY N

DTIC FILE COPY

UNCLASSIFIED 30 004

DEPARTMENT OF DEFENCE
DEFENCE SCIENCE AND TECHNOLOGY ORGANISATION
AERONAUTICAL RESEARCH LABORATORIES

11-1-58 11.5.58

9) T. ... m 0.3

Structures Technical Memorandum 324

STATIC BENDING TESTS ON GRP-VINYL FOAM SANDWICH BEAMS.

10) P.H. TOWNSHEND

14) ... -TM-4

SUMMARY

Static bending tests were made on three beams of glass reinforced plastic (GRP) and rigid vinyl foam sandwich in order to determine their bending strengths and modes of failure.

The static strength data was also required to establish load levels for subsequent bending fatigue tests on this type of sandwich construction which the Royal Australian Navy proposes to use for a catamaran minehunter.

POSTAL ADDRESS: Chief Superintendent, Aeronautical Research Laboratories,
P.O. Box 4331, Melbourne, Victoria, 3001, Australia.

DOCUMENT CONTROL DATA SHEET

Security classification of this page: UNCLASSIFIED

<p>1. DOCUMENT NUMBERS</p> <p>a. AR Number: AR-002-243</p> <p>b. Document Series and Number: STRUCTURES TECHNICAL MEMORANDUM 324</p> <p>c. Report Number: ARL-STRUC-TECH-MEMO-324</p>	<p>2. SECURITY CLASSIFICATION</p> <p>a. Complete document: UNCLASSIFIED</p> <p>b. Title in isolation: UNCLASSIFIED</p> <p>c. Summary in isolation: UNCLASSIFIED</p>
---	---

3. TITLE:

STATIC BENDING TESTS ON GRP-VINYL FOAM SANDWICH BEAMS.

<p>4. PERSONAL AUTHOR: TOWNSHEND, P.H.</p>	<p>5. DOCUMENT DATE: October, 1980</p> <p>6. TYPE OF REPORT AND PERIOD COVERED:</p>
<p>7. CORPORATE AUTHOR(S): Aeronautical Research Laboratories</p>	<p>8. REFERENCE NUMBERS</p> <p>a. Task: NAV 78 024</p> <p>b. Sponsoring Agency: NAVY</p>
<p>9. COST CODE: 26 4700</p>	<p>11. COMPUTER PROGRAM(S) (Title(s) and language(s)):</p>
<p>10. IMPRINT: Aeronautical Research Laboratories, Melbourne</p>	

12. RELEASE LIMITATIONS (of the document):

Approved for Public Release.

12.0 OVERSEAS:	N.O.		P.R.	1	A	B	C	D	E	
----------------	------	--	------	---	---	---	---	---	---	--

13. ANNOUNCEMENT LIMITATIONS (of the information on this page):

No Limitations.

<p>14. DESCRIPTORS:</p> <p>Composite materials. Fiberglass reinforced plastics. Sandwich laminates. Chopped fiber components.</p>	<p>Bend tests. Reinforced plastics. Static tests.</p>	<p>15. COSATI CODES:</p> <p>1104 1402</p>
---	---	---

16. ABSTRACT:

Static bending tests were made on three beams of glass reinforced plastic (GRP) and rigid vinyl foam sandwich in order to determine their bending strengths and modes of failure.

The static strength data was also required to establish load levels for subsequent bending fatigue tests on this type of sandwich construction which the Royal Australian Navy proposes to use for a catamaran minehunter.

CONTENTS

	<u>PAGE NO.</u>
1. INTRODUCTION	1
2. DESCRIPTION OF SPECIMENS	1
3. METHOD OF TESTING	1
4. TESTS AND TEST RESULTS	2
4.1 Specimen No. 1 (2 x 30 mm foam core)	2
4.2 Specimen No. 2 (1 x 60 mm foam core)	3
4.3 Specimen No. 3 (1 x 60 mm foam core)	3
5. DISCUSSION AND CONCLUSIONS	3

REFERENCE

TABLE

FIGURES

DISTRIBUTION

Accession For	
NTIS GRA&I	<input checked="" type="checkbox"/>
DTIC TAB	<input type="checkbox"/>
Unannounced	<input type="checkbox"/>
Justification	
By _____	
Distribution/ _____	
Availability Codes	
_____ and/or _____	
Dist _____	
A	

1. INTRODUCTION

Tests were required to establish the static bending strengths and behaviour of beams of sandwich construction made from glass reinforced plastic (GRP) and rigid vinyl foam core to provide design data for the proposed Royal Australian Navy catamaran minehunter. The tests were conducted in a four-point bending configuration in order to compare the the results with those obtained on a similar type of sandwich construction by the Royal Swedish Navy. The data from these tests will also be used as the basis for the loads for fatigue tests with the same bending configuration.

2. DESCRIPTION OF SPECIMENS

Three sandwich beam specimens of overall dimensions 200 cm long, 30 cm wide, and approximately 78 mm deep were manufactured by the Materials Research Laboratories (MRL). The specimens comprised a 60 mm rigid vinyl foam core sandwiched between skins of glass reinforced plastic made up from eight layers of 300 gm/m² woven roving interspersed with layers of chopped strand mat, bonded together by polyester resin, and starting and terminating with a chopped strand mat layer. The "Klegecell" rigid vinyl foam core was of 130 kg/m³ density and in the first specimen was made up from two 30 mm thicknesses. The two thickness core was originally devised because of initial supply difficulties with 60 mm foam but was considered to be a valid subject for comparison in the event of supply shortages of the designated 60 mm foam.

Two angular butt-joints (included angle 40°) were included in the 30 mm foam, one in each sheet; the joint was formed from resin and talc and was a tentative design for evaluation during this test. The three beams were hand laid up and because of the associated unevenness of the GRP surface it was necessary to cast pads of Epirez 324A epoxy at two locations on each side of the beam to provide level and parallel loading areas.

3. METHOD OF TESTING

The tests were carried out in a universal testing machine using a four point bending rig built up from steel channel beams and steel links. The four-point bending method produces a constant bending moment over the central length between the inner loading points while the shear force is zero; the shear force is constant between the inner and outer loading points. The load was applied at two points situated 400 mm on either side of the beam centreline and reacted at two points 850 mm on either side of the beam centreline, as shown in Fig. 1.

Load was applied by transverse loading or reaction frames astride the beam incorporating a steel angle section knife edge to transmit load into the loading pad and to allow rotational movement of the pad with increasing beam deflection. See Fig. 2.

The loading pads comprised 6 mm thick rubber bonded to the Epirez surfaces backed by a 6 mm thick steel plate bonded in turn to the rubber as illustrated in Fig. 3.

The transverse loading frames were attached to a loading beam mounted on the upper surface of the moving head of a universal testing machine. The reaction frames were attached to another longer beam attached to the lower surface of the fixed head of the testing machine. A general view of the testing gear assembled into the testing machine is shown in Fig. 7.

Electrical resistance strain gauges were installed in five positions on the GRP skins of the second and third beams. Three were situated transversely across the centreline of the beam on the top surface and two on the lower surface opposite to two of the top gauges as indicated in Fig. 4. The gauges were 20 mm gauge length TML-7L-20 and the adhesive used was M-Bond 200.

Two standard dial indicators situated transversely were used to measure deflection at the beam centreline positions.

4. TESTS AND TEST RESULTS

4.1 Specimen No. 1 (core of two-30 mm thicknesses of foam)

As this specimen was manufactured as an interim measure it was decided to use this beam for preliminary tests to check the operation of the test rig, and to ensure that the method of load application to the beam was satisfactory. Some doubts had been expressed on the adequacy of the loading pads due to the relatively low compressive strength of the foam.

Load was applied to the beam in increments of 10 kN and deflections of the centre of the beam were recorded at each increment. Failure occurred at 71.75 kN by shear failure of the foam core between the outer reaction and inner loading frames. The failure appeared to emanate from the centreline of the foam at the top of the V-butt joint probably due to the stress concentration caused by the solid polyester resin-talc wedge.

The failure propagated through the foam at approximately 55° to the GRP-foam joint and along the tension surface to the end of the beam, separating the GRP from the foam core. Some separation of chopped strand mat fibre also occurred. The failure then propagated along the compression surface of the beam from the other end of initial core failure, the foam-GRP joint again separating with some foam failure and some delamination of the chopped strand mat. See Fig. 5. No signs of compression failure were apparent under the loading pads.

4.2 Specimen No. 2 (core of 60 mm thickness foam)

Load was applied to the beam in increments of 10 kN and strain gauge and deflection readings were taken at each increment. Failure occurred at 77.5 kN by shear across the foam core at 55° to the horizontal, the failure propagating along the tension side of the beam through the foam core and then through the adhesive with some delamination of the chopped strand mat. The secondary failure along the compression surface resulted in some shattering of the foam as shown in Fig. 6(a).

Deflection and strain gauge readings are shown in Figs. 9 and 10.

4.3 Specimen No. 3 (core of 60 mm thickness foam)

The test procedure adopted was as for the previous specimen (Para. 4.2).

Failure occurred at 74.5 kN again by shear failure of the foam core at approximately 55° to the horizontal. See Fig. 6(b).

Figs. 7 and 8 show the beam at various loading stages.

Strain gauge and deflection readings are shown in Figs. 9 and 10.

The failures of the three specimens have been photographed together for purposes of comparison in Fig. 11.

5. DISCUSSION AND CONCLUSIONS

The first specimen tested (2 x 30 mm thickness foam) failed at a lower load than specimen numbers 2 and 3 probably due to the polyester-talc joints in the foam. This specimen also exhibited somewhat stiffer load-deflection characteristics probably due to the reduced shear deflection of the core caused by the longitudinal centreline adhesive joint.

Specimens 2 and 3 failed in a similar manner in a similar position - the angles of failure were almost identical. Fig. 12 shows the failure situations of all three beams for comparative purposes.

For the sandwich beams under consideration the shear stress over the depth of the foam core may be assumed to be constant when the flexural stiffness value of the core is considered to be insignificant compared with the flexural stiffness of the GRP skins.

The average shear stress in the foam core for specimens 2 and 3 at failure is approximately therefore:

$$= \frac{Q}{bd} = \frac{38,000}{300 \times 68} = 1.86 \text{ MPa} \quad \text{where} \quad \begin{array}{l} Q = \text{shear force} \\ b = \text{breadth} \\ d = \text{depth centre to centre,} \\ \text{GRP skins.} \end{array}$$

This value compares favourably with the figure of 1.90 MPa from torsion tests on 50 mm diameter cylinders carried out at MRL.

Comparison with Royal Swedish Navy results (Ref. 1) can only be tentative because full details of the sandwich construction have not been provided e.g. GRP skin thickness and failing load are quoted but no details of the skin construction or foam thickness are given.

However comparative results are tabulated in Table I and if due allowance is made for some assumed values ARL results compare favourably with those available from Sweden.

The average failing load of specimens 2 and 3 was 76 kN, this value will be used as a basis for the subsequent fatigue tests on similar sandwich beam specimens.

REFERENCE

1. Torkild Rand and Karl Axel. Sandwich Laminate of GRP/Expanded P.V.C. Plast forum. Nos. 4 and 5, 1976.

TABLE I. COMPARATIVE TEST RESULTS A.R.L.-SWEDEN

Ref.	GRP skin thickness mm.	Foam core thickness mm.	Foam core density Kg/m ³	EM at failure Nm	Shear Stress in core MPa	Direct Stress in skin MPa	Location of failure
ARL NO. 1	8	2 x 30	130	16,140	1.76	98.9	core
ARL NO. 2	8	60	130	17,430	1.90	107	core
ARL NO. 3	8	60	130	16,760	1.83	103	core
SWEDISH INST. OF TECHNOLOGY	12	60	100	13,790*	1.68	63.6	core
	12	60	150	23,400*	2.82	112.8	core
	12	60	200	29,900*	3.64	146.7	skin
	12	90	200	40,725*	3.28	143	skin

* Estimated Value

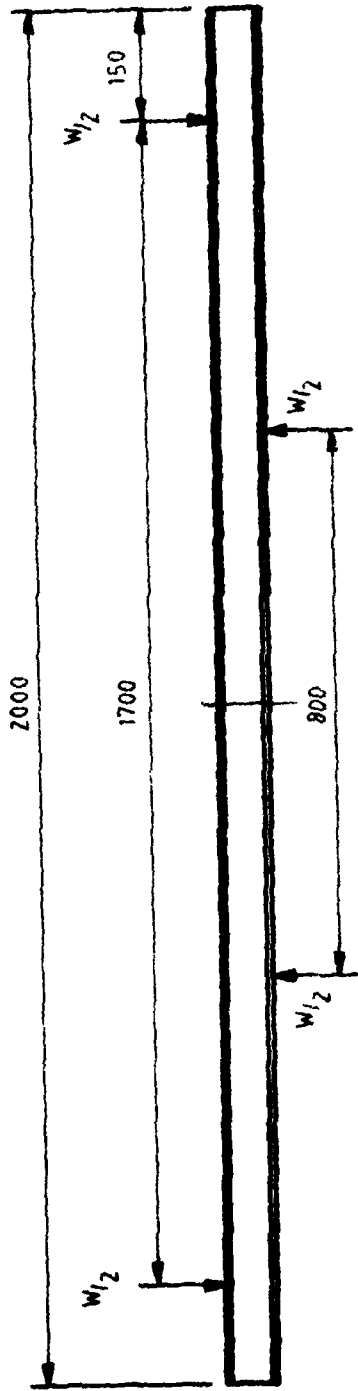

Beam width 300
All dimensions mm

FIG. 1 LOADING DIAGRAM

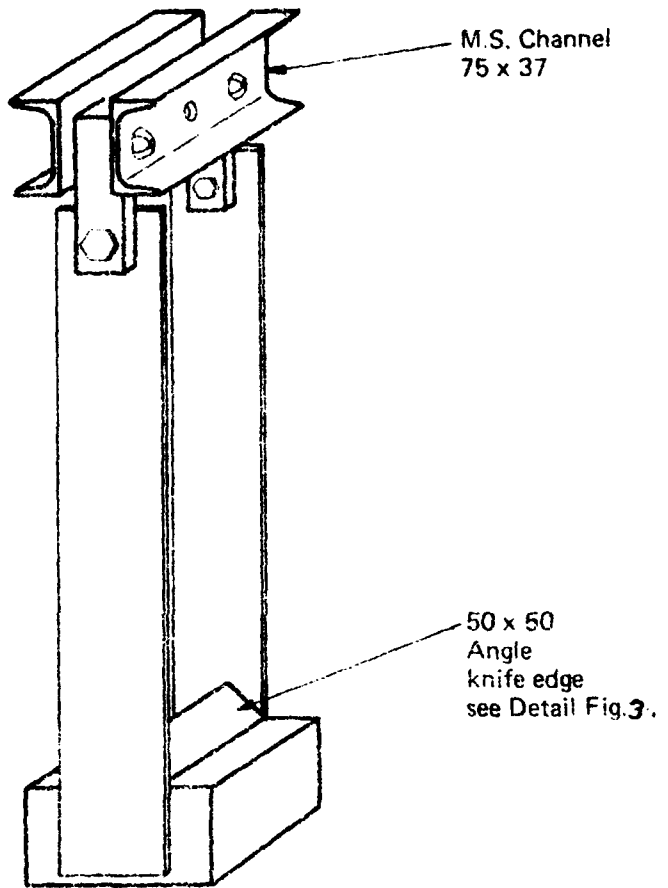

All dimensions in mm.

FIG. 2 DETAIL OF LOADING FRAME

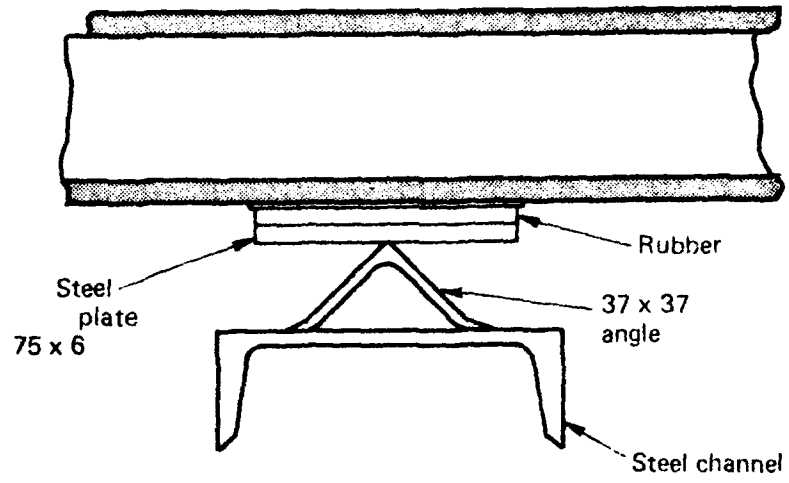

All dimensions in mm

FIG. 3 DETAIL OF LOADING PAD

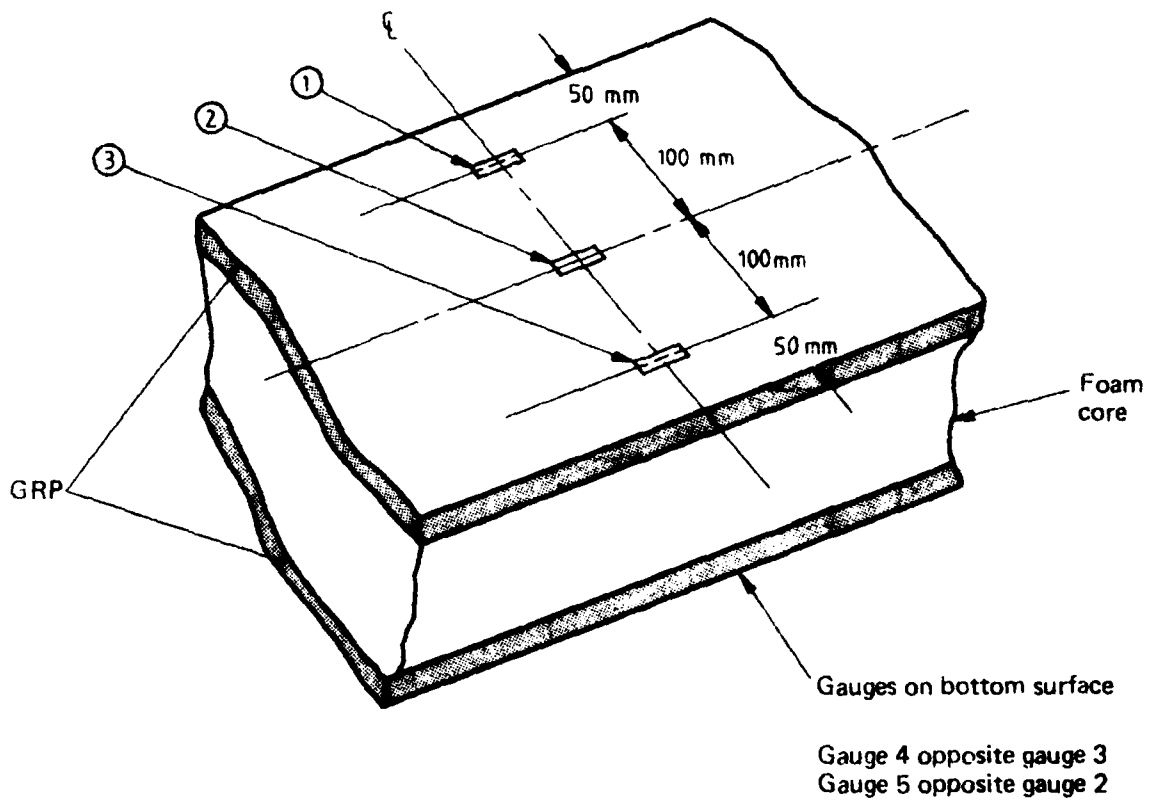

FIG. 4 STRAIN GAUGE POSITIONS



FIG. 5 DETAIL OF FAILURE - NO 1 BEAM



(a) Detail of failure No 2 beam



(b) Detail of failure No 3 beam

FIG. 8 FAILURE OF MINEHUNTER BEAMS SPECIMENS 2 & 3



(a) Beam No 3 at zero load



(b) Beam No 3 at 70kN load

FIG. 7 LOADING OF MINE HUNTER BEAMS SPECIMEN NO 3

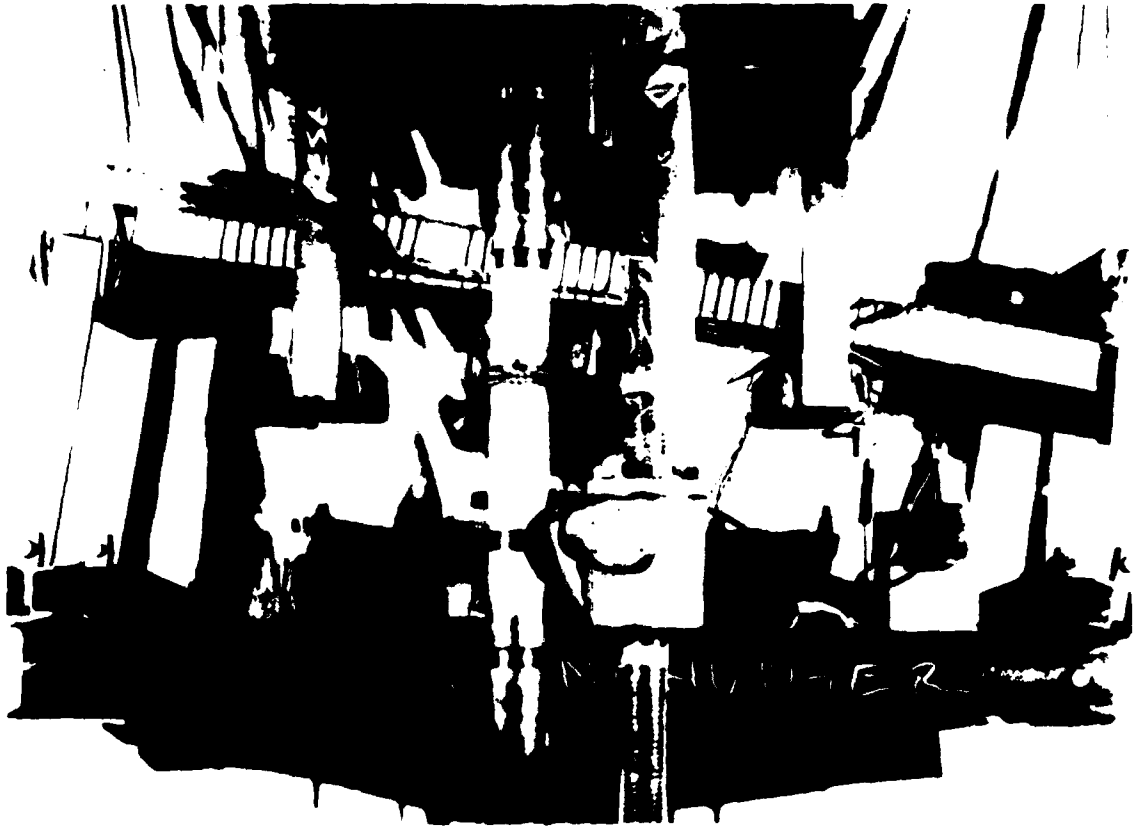

FIG. 8 BEAM NO 3 AFTER FAILURE AT 74.75kN LOAD

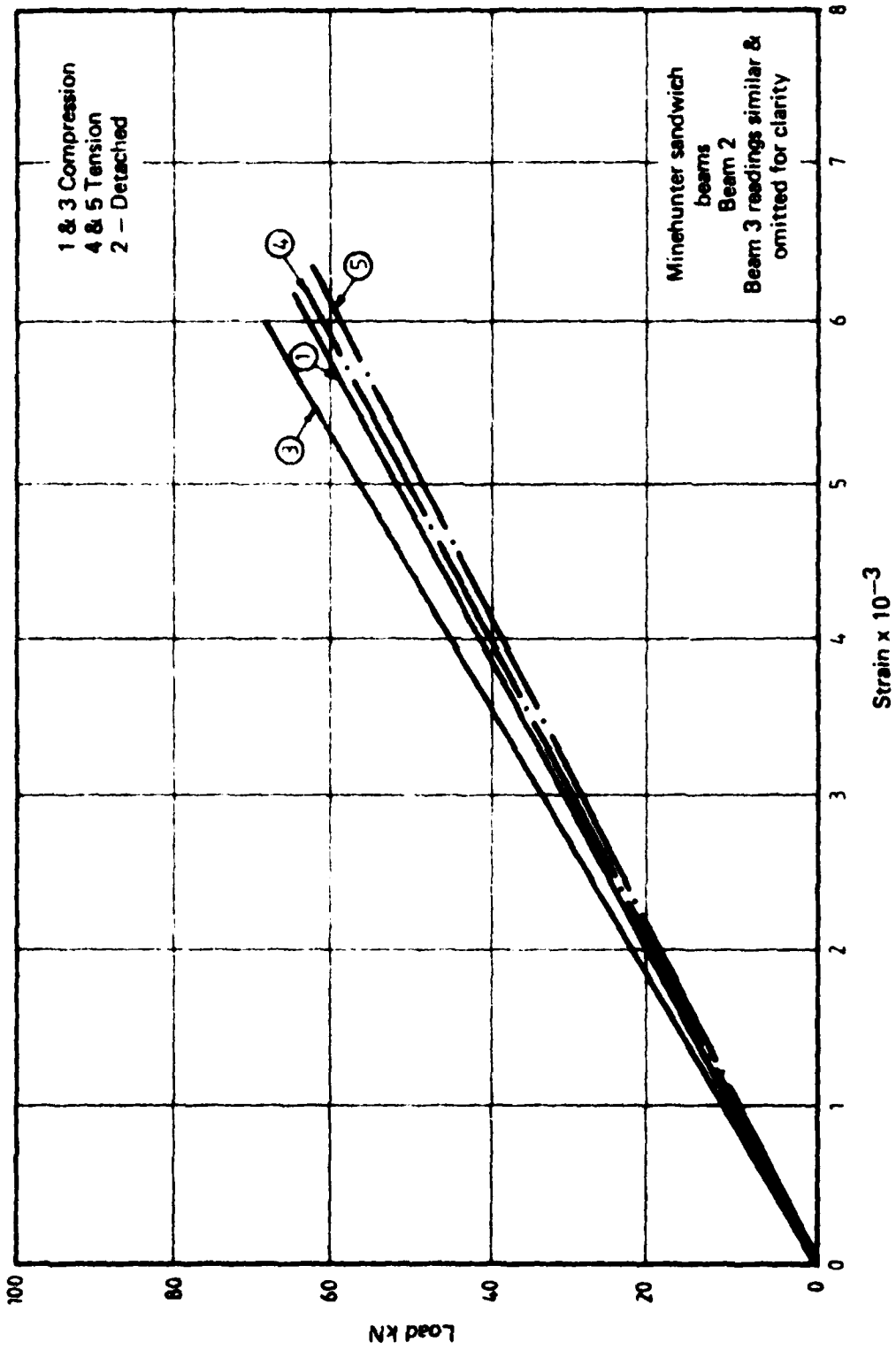

FIG. 9 STRAIN IN GRP SKINS (FOR GAUGE POSITIONS SEE FIG. 4)

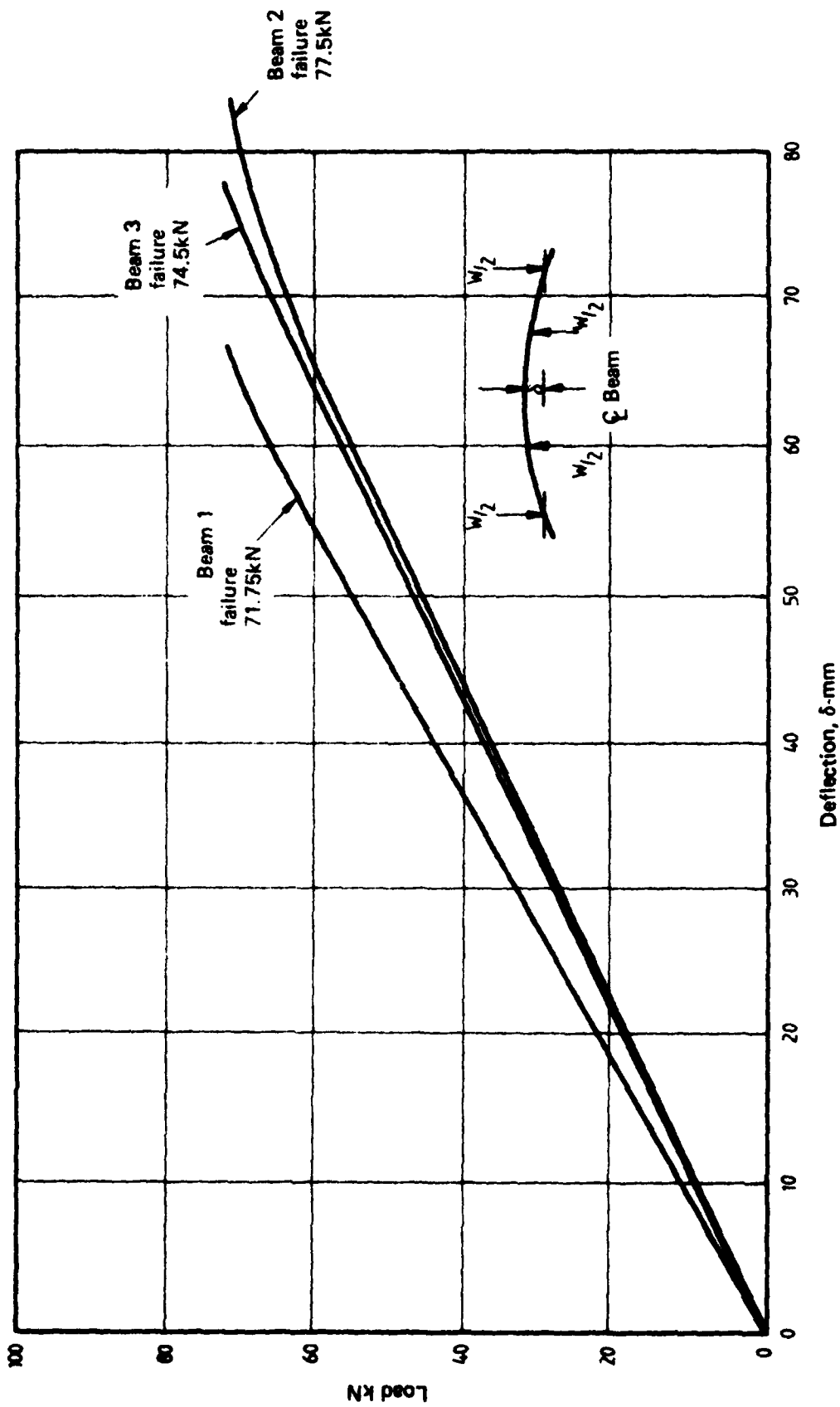
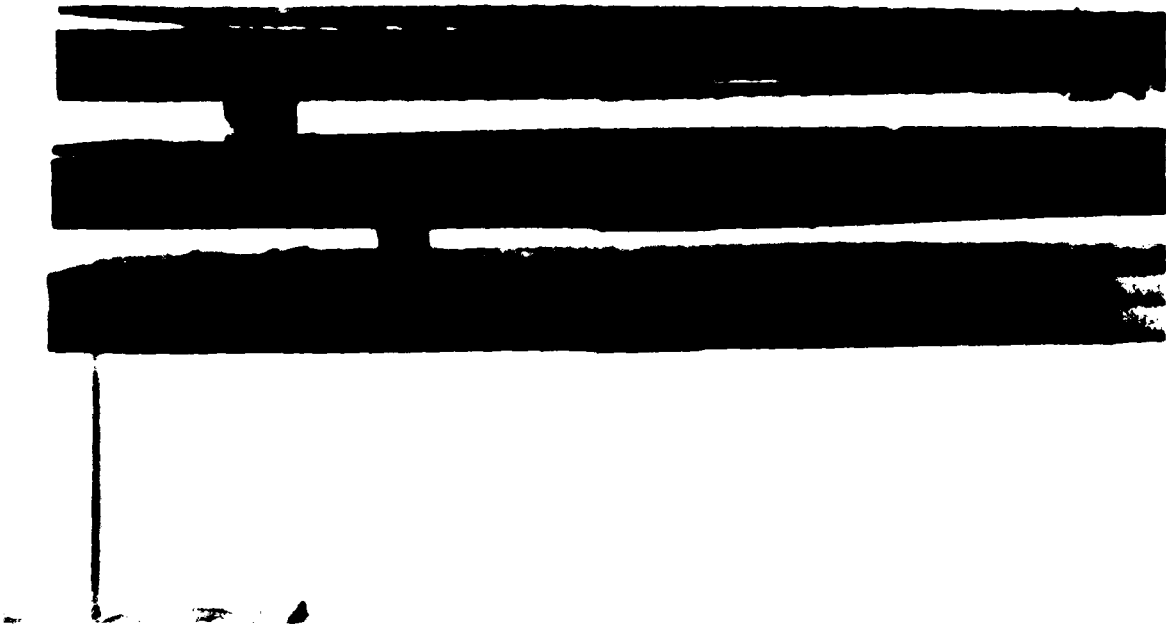
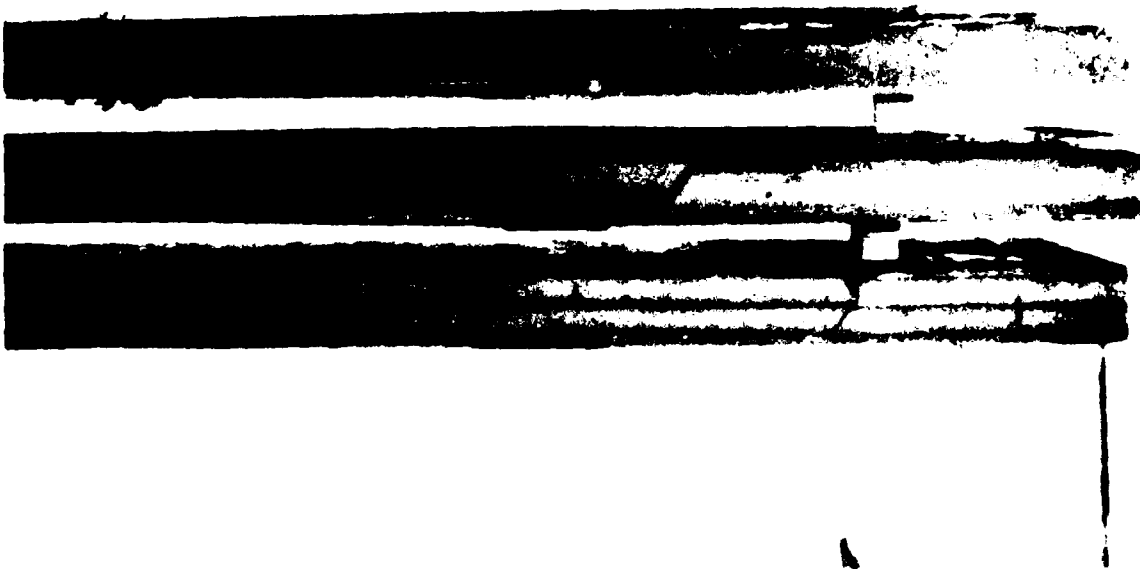

FIG. 10 OVERALL BEAM DEFLECTION MEASUREMENTS



(a) Failures of three beams. Viewed from right.



(b) Failure viewed from opposite side (left)

FIG. 11 MINEHUNTER BEAMS AFTER FAILURE

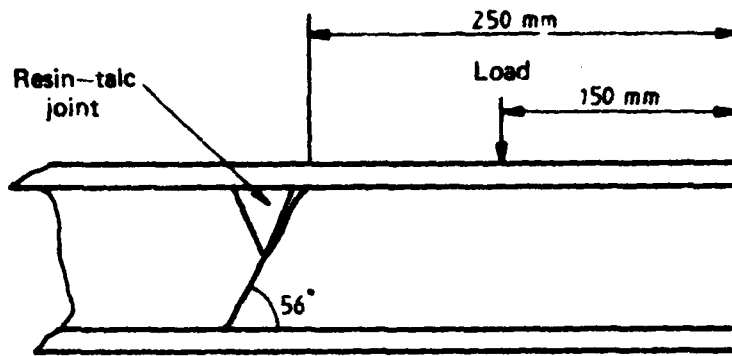

Beam no 1 (2 x 30mm core)

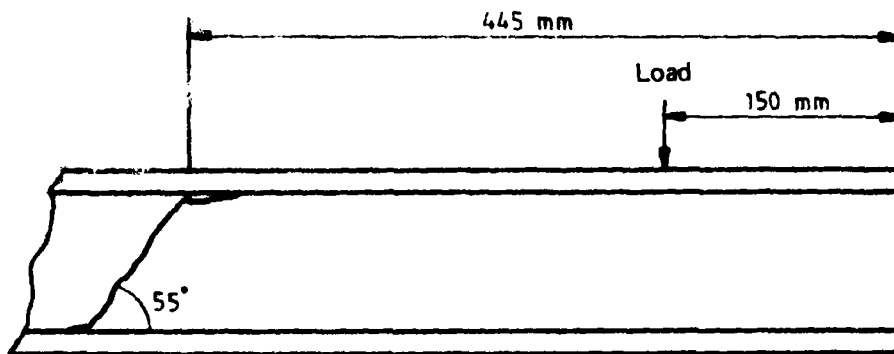

Beam no 2 (60mm core)

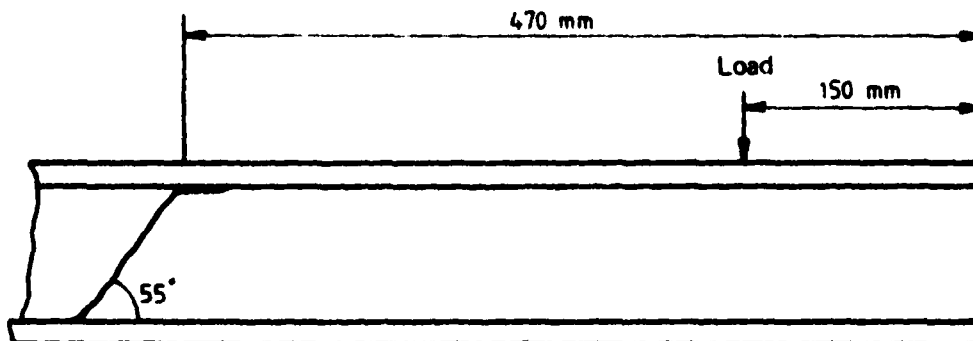

Beam no 3 (60mm core)

Positions of failures in foam core

FIG. 12 MINEHUNTER BEAMS

DISTRIBUTION

COPY NO.

AUSTRALIA

Department of Defence

Central Office

Chief Defence Scientist	1
Deputy Chief Defence Scientist	2
Superintendent, Science and Technology Programs	3
Australian Defence Scientific and Technical Rep. (UK)	-
Counsellor, Defence Science (USA)	-
Joint Intelligence Organisation	4
Defence Central Library	5
Document Exchange Centre, D.I.S.B.	6-22
DGAD (NCO)	23

Aeronautical Research Laboratories

Chief Superintendent	24
Library	25
Superintendent - Structures Division	26
Divisional File - Structures	27
Author: P.H. Townshend	28
C.A. Patching	29
B.C. Hoskin	30
A.A. Baker	31
R.G. Parker	32

Materials Research Laboratories

Library	33
B. Paul, Polymer Group	34

Defence Research Centre, Salisbury

Library	35
PO/SI - Dr. J. Wilson	36
L. Drummond, Prop. and Marine Chemistry	37

Central Studies Establishment

Information Centre	38
--------------------	----

Engineering Development Establishment

Library	39
---------	----

RAW Research Laboratory

Library	40
---------	----

DISTRIBUTION (CONTD.)

COPY NO.

Defence Regional Office

Library 41

Navy Office

Naval Scientific Adviser 42

Design Branch - DGND - J.G. Cameron 43

A/DNSD, B. Robson 44

Army Office

Royal Military College Library 45

Air Force Office

Air Force Scientific Adviser 46

UNITED KINGDOM

Royal Aircraft Establishment.

Farnborough, Library 47

Bedford, Library 48

Admiralty Materials Laboratories, Dr. R.G. Watson 49

Naval Construction Research Establishment, Superintendent 50

SPARES

51-56

ATE
LMED
-8