

AD-A098 404

FOREIGN TECHNOLOGY DIV WRIGHT-PATTERSON AFB OH
HOLOGRAPHIC MEMORY DEVICES WITH INJECTION LASERS. (U)
FEB 81 V N MOROZOV
FTD-ID(RS)T-0893-80

F/G 14/5

UNCLASSIFIED

NL

101
5000000



0

END
DATE
FILMED
5 81
DTIC

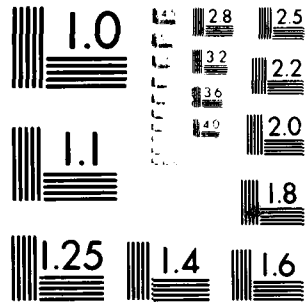

MICROCOPY RESOLUTION TEST CHART
NATIONAL BUREAU OF STANDARDS-1963-A

514

FTD-ID(RS)T-0893-80

2

FOREIGN TECHNOLOGY DIVISION



HOLOGRAPHIC MEMORY DEVICES WITH INJECTION LASERS

by

Valentin Nikolaevich Morozov

S DTIC
ELECTE
MAY 0 4 1981
D
E

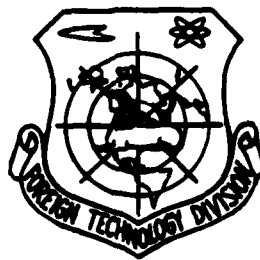

Approved for public release;
distribution unlimited.

AD A 098 404

DTIC FILE COPY



8 1 3 1 7 0 5 8

EDITED TRANSLATION

(14) FTD-ID(RS)T-0893-80 (11) 9 February 1981

MICROFICHE NR: FTD-81-C-000109

(5) HOLOGRAPHIC MEMORY DEVICES WITH INJECTION LASERS,

By (10) Valentin Nikolaevich/Morozov

English pages: 20

(21) Source: Rozprawy Elektrotechniczne, 25, (Poland) 1979, Nr. 3, 1979, pp. 749-762 1979.

Country of origin: Poland

Translated by: SCITRAN
F33657-78-D-0619

Requester: FTD/SDEO

Approved for public release; distribution unlimited.

Accession For	
NTIS GRA&I	<input checked="" type="checkbox"/>
DTIC TAB	<input type="checkbox"/>
Unannounced	<input type="checkbox"/>
Justification	
By _____	
Distribution/	
Availability Codes	
Dist	Avail and/or Special
A	

<p>THIS TRANSLATION IS A RENDITION OF THE ORIGINAL FOREIGN TEXT WITHOUT ANY ANALYTICAL OR EDITORIAL COMMENT. STATEMENTS OR THEORIES ADVOCATED OR IMPLIED ARE THOSE OF THE SOURCE AND DO NOT NECESSARILY REFLECT THE POSITION OR OPINION OF THE FOREIGN TECHNOLOGY DIVISION.</p>	<p>PREPARED BY: TRANSLATION DIVISION FOREIGN TECHNOLOGY DIVISION WP.AFB, OHIO.</p>
---	--

14155

HOLOGRAPHIC MEMORY DEVICES WITH INJECTION LASERS¹.

Valentin Nikolaevich Morozov
(Moscow)

The P.N. Lebedev Physics Institute of the
Academy of Sciences of USSR

Received Feb. 23, 1978

The subject of this work concerns the problems related to the application of injection lasers to the construction of opto-electronic memory of the ROM type. The main optical requirements for lasers and holograms used for this purpose are analysed. The analysis is supported by appropriate calculations and experimental data.

1. INTRODUCTION

Studies directed to the construction of permanent holographic memory of the ROM (read-only memory) type have accelerated recently. Many specialists believe that opto-electronic memory will replace the existing or currently studied other types of memory of the ROM type [1-4]. The holographic memory record has many important advantages over other types of recording. The holographic record has interference character. Thus the information is distributed over the entire surface of the hologram, which assures high reliability of its storage. In addition, the same surface undergoing multiple exposure can store a large number of holograms. Holographic memory can be endowed with functions of information

¹Article based on the lecture given by the author at the seminar "Semiconductor lasers", organized by the Physics Institute of PAN on Sept. 26, 1977 in Warsaw.

processing [5-6].

Holographic memory devices with free choice and block organization of the information contain the following basic subunits: laser, deflection system, hologram matrix and photodetector matrix. Each block of information is recorded on a separate hologram. The laser radiation is directed onto any hologram using a fast-acting deflection system. During illumination of a given hologram by a laser beam, the cards with information recorded in the form of a collection of light and dark points are projected onto a matrix of photodetectors transforming the signals of light into electric pulses. The content of all holograms is projected onto the same matrix of photodetectors, so that a single set of photodetectors is sufficient for reading all the holograms.

Fig. 1 represents a diagram of a holographic memory device. Sources of radiation are usually helium-neon lasers, while beam deflection is achieved by electro-optical or acoustic-optical deflectors.

A serious disadvantage of helium-neon lasers is their low efficiency, reaching about 0.1%. In addition, the large size of these lasers and the necessity of using high voltages for their charging make it more difficult to construct miniaturized optical memories.

1750

A new and very promising concept is the application of coupled lasers as the source of radiation for holographic memory [1, 7, 8]. High efficiency, ranging from 10 to 50%, small size of the coupled laser, simplicity of charging and small inertia make it an almost ideal source of radiation for holographic memory. The possibility of generating matrices of integrated bands of coupled lasers leads to a significant simplification of the beam deflection system.

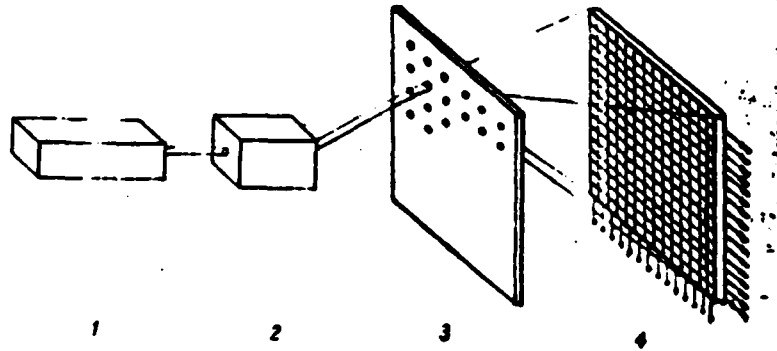

Fig. 1. Idealized diagram of holographic memory device. 1-laser, 2-deflector, 3-matrix of holograms, 4-matrix of photodetectors.

A coupled laser has many properties distinguishing it from solid-state lasers and gas lasers. When the excitation is carried out by currents much stronger than the threshold value, the radiation has a multi-mode character. A characteristic property of coupled lasers is the considerable difference between the dimensions of the active area along the coupling and across it.

If the active area has a width greater than 30-40 μm , there are generated in it separate fibers of radiation of 10-20 μm width. Emission of radiation from individual fibers is independent.

We will now discuss the results of a series of studies on the effects of time and spatial coherence of radiation of coupled lasers on the quality of the image reproduced from holograms.

2. TIME AND SPATIAL COHERENCE OF RADIATION OF COUPLED LASERS.

The spatial coherence of radiation of semiconductor lasers in the far range is related to the modal structure and the distribution of the energy of radiation field on the

output mirror. The spatial coherence depends strongly on the structure of transverse modes, but is practically independent of the type of laser operation (continuous or pulse operation). Fig. 2. shows the dependence of the modulus of the spatial coherence function of radiation on angular distance between the points on the surface of the front of radiation wave under study, the radiation being emitted by a semiconductor laser for various pumping currents. /751



Fig. 2. Dependence of the modulus of spatial coherence function on angular distance between points.

Curve 1 corresponds to the direction perpendicular to the coupling p-n, curves 2 and 3 - to the direction parallel to the coupling. For curve 2 the pumping current is greater by 30% than the threshold value, and for curve 3 - by 50%.

In the case of single-mode operation the spatial coherence remains constant within the limits of the measurement in both planes - parallel and perpendicular to the plane of the coupling. An increase in pumping current and transition of laser operation to multi-mode operation does not alter the coherence in the long range in the plane perpendicular to the coupling, but the coherence in the parallel plane is significantly worsened.

In the first approximation, the wide coupling p-n can be

identified with a heat source with transverse dimensions equal to the length of the coupling. An increase of spatial coherence in the direction parallel to the coupling can be achieved by decreasing its transverse dimensions or by isolating individual radiation fibers.

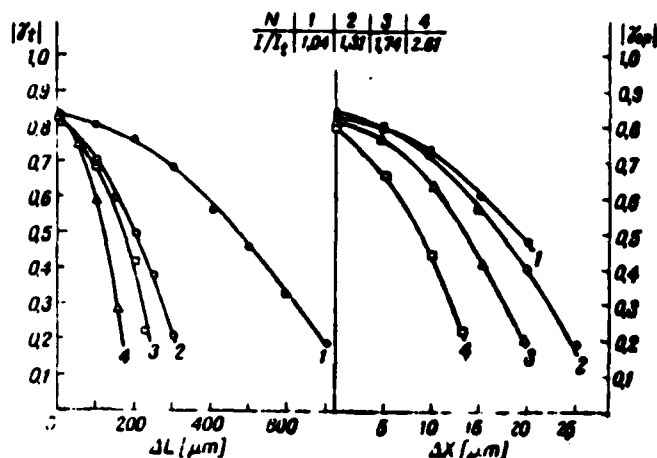

Fig. 3. Spatial and time coherence of pulse radiation of a coupled laser operating at room temperature [9].

When the threshold current is exceeded by 5-10%, or more, coupled lasers go into multi-mode operation. The width of radiation spectrum is then 10-30 Å, which corresponds to a coherence path of only several hundreds of microns.

Fig. 3 . shows the absolute values of the spatial and time coherence function for the radiation of coupled pulse laser operating at room temperature [9]. Curves 1-4 correspond to currents exceeding the threshold value by 5, 30, 75 and 250%, respectively. From a comparison of the curves it can be seen that coherence and radiation of coupled lasers depend strongly on the pumping current. The area of the laser from which coherent radiation is emitted and the length of coherence path are decreased with increased pumping current.

3. REPRODUCTION OF HOLOGRAMS USING SEMICONDUCTOR LASERS.

The effect of partial coherence of radiation from coupled lasers on the quality of the image reproduced from a hologram has been studied theoretically as well as experimentally.

The theoretical analysis is based on the wave equation for reciprocal coherence function. When the illumination of the hologram is uniform, the distribution of image intensity along the x-axis is given by the following formula²:

$$I(x) = I_0 \frac{1}{2\rho_0} \int_{-\infty}^{\infty} \text{sinc}^2 \left(\frac{ax}{\lambda z_0} + \rho \right) d\rho.$$

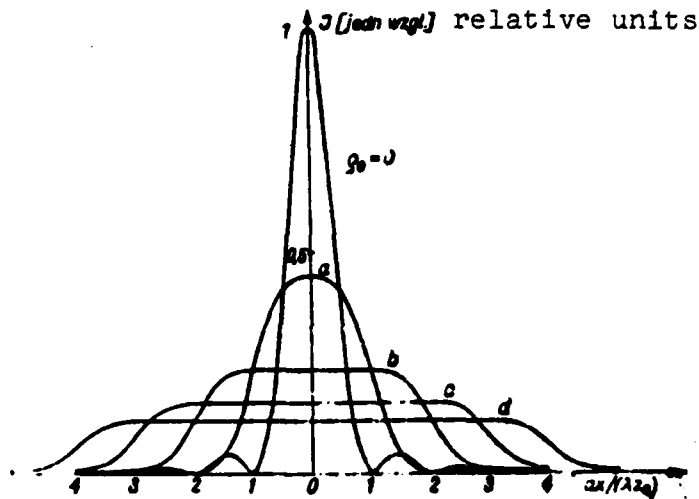

Fig. 4. Distribution of image intensity of a point depending on the degree of spatial coherence. Curves a,b,c,d were obtained by assuming the value ρ_0 equal to 1,2,3, and 4, respectively [10].

²The symbols appearing in this formula represent the following: I_0 - the intensity of the source, z_0 - distance from the source to the hologram. The author used the notation accepted in diffraction theory:

$$\text{sinc } x = \frac{\sin x}{x}$$

where $\rho = \frac{a}{2\theta_0 F}$ a - diameter of the hologram, F - distance of the source from the hologram, θ_0 - angle of spatial coherence. The quantity θ_0 is the ratio of the angular dimensions of the hologram to the angle of spatial coherence [10].

Fig. 4. shows the value of the integral which appears in the formula above for various angular dimensions of the source. The axis corresponds to the intensity and the unitless quantity $ax/\lambda z_0$. The value $\rho_0 = 0$ corresponds to the limiting case of completely spatially coherent radiation. The image of the point is in this case the same as the diffraction image. For $\rho_0 = 1$ (curve a) the degree of reciprocal coherence for a pair of points located at the center and at the edge of the hologram equals zero. For $\rho_0 > 1$ the dimensions of the image are inversely proportional to the angle of spatial coherence. It follows that if the angular dimensions of the source exceed the value of the diffraction angle of the hologram, then the size of the image begins to depend on the size of the source.

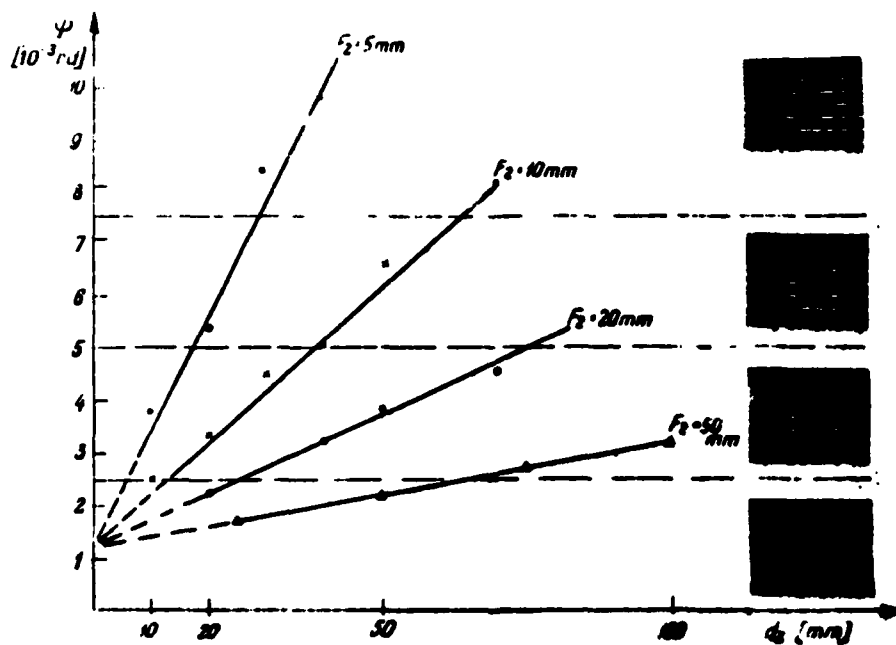

Fig. 5. Dependence of angular dimensions of the image reproduced on the width of the active area of coupled laser [11].

Fig. 5. shows the experimental curves which illustrate the dependence of altering the angular dimensions of a point in the image reproduced on the width of active area (along the p-n coupling). Curves 1-4 were obtained for different focal lengths of the lens used in reproduction. The distance of the hologram from the image was constant. The decrease in the dimensions of point images with the altering width of active area is limited by factors such as diffraction on the hologram aperture and the spectral width of reproducing radiation. On the right hand side of the same figure we show fragments of the image of 10^3 points from a hologram with a diameter of 1 mm. The signal/noise ratio for light and dark points in the image reproduced reached 20-30. The width of active area in the series of photographs from the lowermost to the top was 20, 40, 60, and 80 μ m, respectively. The widening of a point image in the direction perpendicular to the coupling p-n is small, since the thickness of active area was only 1-3 μ m [11].

/754

An evaluation of the effect of spectrum width of coupled laser radiation on the quality of image reproduction can be carried out based on the approximate formula for angular dimensions of a "point":

$$v \approx 2 \frac{\lambda}{a} \left[1 + \frac{4\lambda}{\lambda^2} a \left(\frac{\lambda}{2} + \sin \theta \right) \right].$$

The first term of this expression corresponds to the dimensions of the point which follow from diffraction on the hologram aperture, the second describes the magnification of the point related to the spectral radiation width. It can be seen that the decisive factor is the ratio of the difference of the paths of two extreme rays interfering with each other and creating the image of a point, to the length of radiation coherence. For angle $\theta=15^\circ$ and hologram diameter $a=1$ mm, the dimensions of a point double compared to its diffraction image

at spectrum width equal to 20\AA . The widening of the image in the direction perpendicular to interference lines is smaller [10].

Taking into account also the extent of the source such as a coupled laser, it is possible to estimate the angular dimensions of a point reproduced from a hologram using the following approximate formula: $\psi = 2,44 \frac{\lambda}{a} + \frac{d_x}{F} \cos \theta + \frac{\Delta \lambda}{\lambda} \left(\frac{A}{2} + \sin \theta \right)$.

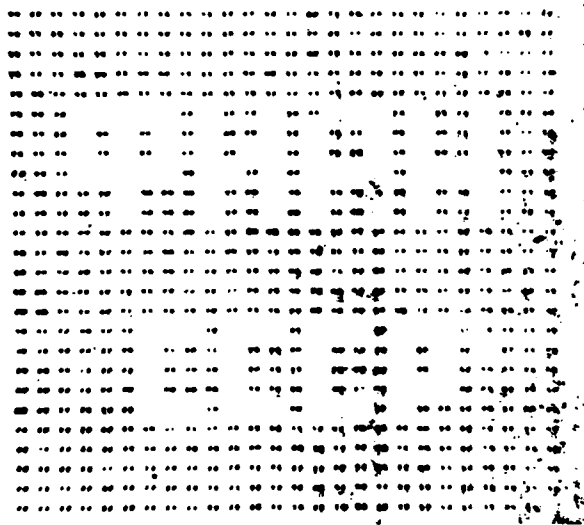

Fig. 6. Fragment of an image reproduced using a coupled laser from a hologram with recording density of 10^4 bits/mm².

The first component here is the diffraction image of a point, while the second is related to the extent of radiation source. The width of p-n coupling is denoted by d_x . As follows from this, the number of points capable of being reproduced from a hologram with diameter a using a coupled laser with spectral line width $\Delta \lambda$ and coupling width d_x , is given by the formula:

1755

$$N = \left[2,44 \frac{\lambda}{a} + \frac{d_x}{F} \cos \theta + \frac{\Delta \lambda}{\lambda} \left(\frac{A}{2} + \sin \theta \right) \right]^2$$

where A is the relative aperture of the objective used during hologram recording (7).

Fig. 6. shows a fragment of an image with the number of points equal to 10^4 , reproduced using a coupled laser from a hologram with diameter of 1 mm. The signal/noise ratio in the image is greater than 20. The width of active area of the laser used was $20\mu\text{m}$, the focal length of the collimating lens, $F=10$ mm, and spectral line width - 15\AA .

4. HOLOGRAM GENERATION USING COUPLED LASER RADIATION.

Up to now we have considered the problem of hologram reproduction using the radiation of coupled lasers, while the holograms were obtained using a helium-neon laser. Alteration of the wavelength of the source which reproduces the hologram causes significant worsening of image quality for large holograms because of aberration. However, if the hologram has a surface of the order of 1 mm^2 , the aberration is relatively small and the main effect related to the change in wavelength reduces to a change in spatial location of the point.

As a result of experimental studies, holograms have been generated using radiation of coupled lasers. The holographic image was registered in plates of material sensitive to infrared, optimized for wavelength $\lambda=0.85\mu\text{m}$ emitted by a semiconductor laser. The plates had a sensitivity of 10^{-6} J/mm^2 and a discriminating capacity at least 1500 lines/mm. Creation of microholograms using coupled lasers with small spatial and time radiation coherence is possible because the difference of optical paths between the reference beam and the terminal element of the plate is also small for small holograms. Fig. 7. shows the required spatial and time length of coherence necessary for recording holograms. It can be seen that

/756

$$\Delta l_t = \lambda \cdot \theta$$

$$\Delta l_t = \dots$$

$$\Delta l_{sp} = \frac{\lambda \cdot K}{K}$$

$$\Delta l_{sp} = 14 \mu m$$

$$A = \frac{a}{F} = 0.3$$

$$a = 1 \text{ mm}$$

$$\theta = 30^\circ$$

$$a = 1 \text{ mm}$$

$$\theta = 30^\circ$$

$$K = 60$$

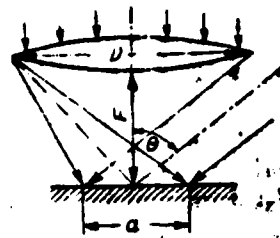

a - hologram diameter

K = powiększenie układu optycznego

Fig. 7. Diagram of hologram record and the requirements imposed on the coherence of coupled lasers [9]. The symbols appearing in Fig. 7 denote the following: Δl_t - length of time coherence, /illegible/ used to record the hologram, Δl_{sp} - length of spatial coherence. a - diameter of hologram, K - enlargement of optical system.

generation of holograms with an area of the order of 1 mm^2 is possible even when meeting extremely stringent requirements. The lowering of the density of recording data, resulting from insufficient spatial coherence can be avoided by an appropriate choice of optical system enlargement during collimation of the laser beam. The basic factor limiting the density of information recording is therefore the degree of time coherence. Because coupled lasers operating at room temperature have relatively low time coherence, it is necessary to equalize carefully the optical paths during hologram generation. The maximum difference of these paths can be at most 10% of the length of time coherence.

Fig. 8. shows a photograph of an actual plate image containing approximately 1000 elements, recreated on the basis of a hologram. The intensity of pumping current was 1.5 of the threshold value, which corresponded to the length of spatial coherence of $170 \mu m$ and the length of coherence area in the coupling p-n of $14 \mu m$. The average radiation energy of a coupled laser required to generate a hologram with a diameter

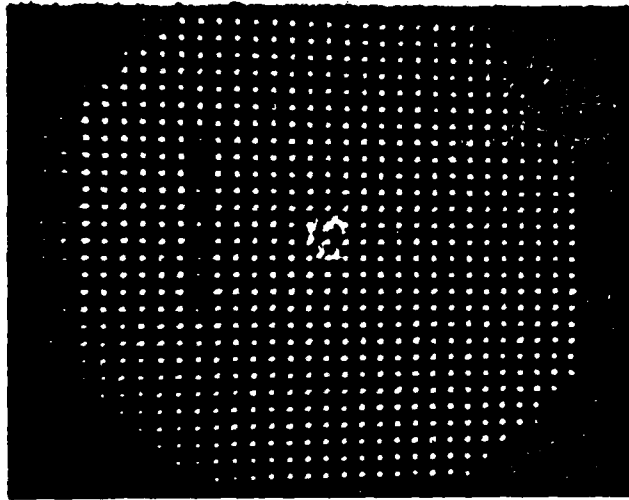

Fig. 8. Photograph of the image of a holographic plate recreated on the basis of coherent laser [9].

of 1 mm illumination time of 1 second was 10^{-4} J. The diffraction selectivity of the hologram was amounted to 12% and the signal-to-noise ratio for the entire area of the image recreated from the hologram amounted to at least 10 [9].

In memory systems with coupled lasers the matrices of holograms are often produced using gas lasers. The difference between the wavelengths of radiation from the source generating and regenerating the hologram causes certain shifts of the elements of the images regenerated from different holograms. This results in limiting to some extent the informational capacity of the memory. Therefore calculations were made of the limit capacity of opto-electronic memory. Also, the optimal values of parameters for which maximum capacity can be achieved were determined.

757

The calculations conducted indicate that the limit capacity in the case of hologram generation using He-Ne laser and their reading using coherent laser is 3×10^7 bits. This maximum value is achieved for holographic plates and rasters

of collimation lenses with dimensions of 30 mm, hologram diameter equal to 1 mm and the distance of holographic plates from the raster equal to 240 mm. The distance between the centers of photodetectors and between the information points is here 200 μm [12].

5. ENERGY RELATIONS.

A radiation photodetector can be a matrix of silica diodes with sensitivity within the range of $10^{-12} - 10^{-14}$ J. If the minimum energy required for registering a signal from the photodetector is denoted W_ϕ , the diffraction effectiveness of the hologram - η , the losses on optical elements - σ , and the number of elements of the image - N , then the minimum energy required for the laser equals:

$$W_{\text{min}} = \frac{W_\phi N}{\eta \sigma}.$$

A laser with the width of p-n coupling equal d_x delivers during the time of exposure t the energy equal

$$W_{p-n} = k d_x t = \frac{k t F \sigma}{\sqrt{N}},$$

where k - power of semiconductor laser corresponding to a unit of the width of the coupling.

Fig. 9. shows the graphs of the dependence of minimum radiation energy of the laser on the number N of photodiodes in the matrix. Broken lines a and b determine the level of energy required for foolproof registration of the image by a matrix containing N photodiodes. Curves 1-3 illustrate the dependence of the laser energy radiated in 100 ns, 200 ns, and 1 μs , respectively, on the number N of bits in the image regenerated. The use of semiconductor lasers with energy parameters lying above the curve a or b assures foolproof

758

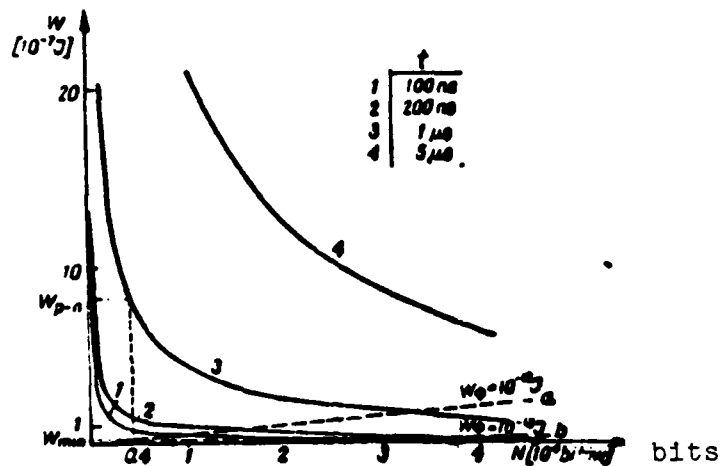

Fig. 9. Energy dependencies in a system consisting of a coupled laser, hologram and a matrix of photodetectors.

registration of the regenerated image using photodiodes. Modern band long-life lasers with an active area of width 10-20 μ m have an average power of the order of 10mW. For a pulse of length 10 ns , diffraction effectiveness of the hologram 20% and energy corresponding to one photodetector equal to 2×10^{-13} J, the required pulse power is 100mW. Therefore, for an average power of ~ 10 mW and an amount of information of 10^4 bits the average reading frequency is about 1 MHz.

6. BASIC DIAGRAMS OF HOLOGRAPHIC MEMORY SYSTEMS WITH COUPLED LASERS

The application of coupled lasers to holographic memory can significantly reduce its dimensions and energy usage and simplify the optical systems. One of the possible constructions of holographic memory of ROM type is represented in Fig. 10. The memory consists of a matrix of coupled lasers with a raster of collimation microlenses, a matrix of holograms, and a matrix of photodetectors. Each hologram contains an information block with 10^4 bits capacity. The choice

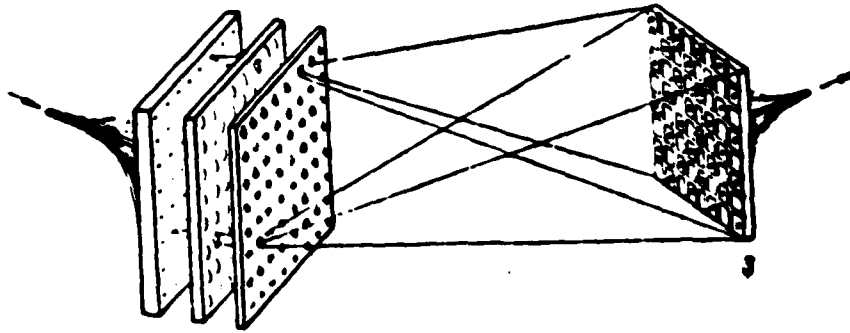

Fig. 10. Idealized diagram of holographic memory containing a matrix of coupled lasers. 1 - laser matrix, 2 - hologram matrix, 3 - photodetector matrix.

of any arbitrary information card is realized by turning on the appropriate laser in the matrix. The actual image regenerated from any hologram is projected onto the photodetector matrix which transforms light signals into electrical pulses. If the hologram has a capacity of 10^4 bits, then the memory with a capacity of 10^7 bits must contain 10^3 coupled lasers.

A significant reduction of the number of lasers while maintaining unchanged memory capacity can be achieved by using strips of coupled lasers and a single-dimension deflector of radiation.

An experimental system of holographic memory has been constructed in which a parallel radiation beam of a coupled laser is deflected by an acoustic-optical deflector containing an ultrasound cell of lead molybdate. A diagram of such a memory is shown in Fig. 11. The choice of level destination is achieved by turning on the appropriate laser in the band, and vertically - by deflection of the beam by appropriate angle. If there are 64 lasers in the band and the deflector makes it possible to deflect the beam in 64 posi-

/759

tions, then the total memory capacity at hologram capacity equal to 10^4 bits is 4×10^7 bits.

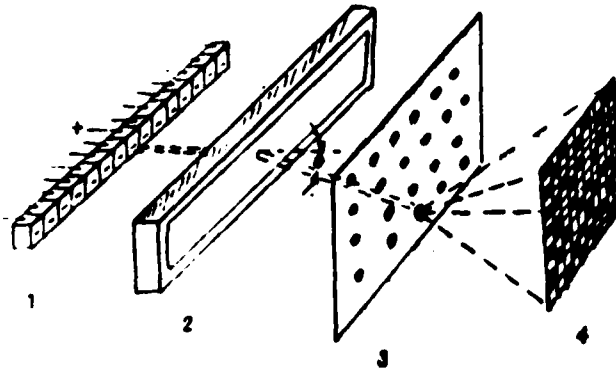

Fig. 11. Idealized diagram of holographic memory with a band of coupled lasers. 1 - laser band, 2 - single-dimension deflector, 3 - hologram matrix, 4 - photodetector matrix.

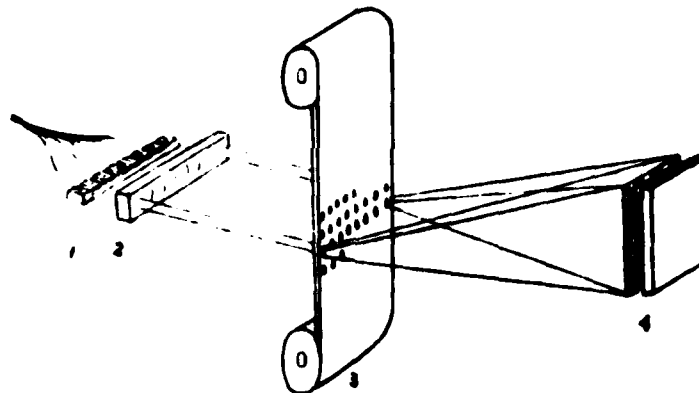

Fig. 12. Idealized diagram of enlarged holographic memory with a band of coupled lasers. 1 - laser band, 2 - deflector, 3 - tape with holograms, 4 - photodetector matrix.

The capacity of holographic memory with free choice is limited to 10^8 bits, which is related to the fact that the diameters of accessible optical systems usually do not exceed 30-50 cm. However, it can be considerably increased by using the method of hologram matrix exchange. Fig. 12 shows a diagram of such a system of memory with increased hologram set.

...и был экспериментально и в 1964 г.
 Он не только использовал формулы в море
 Ином раз, пытаюсь вывести при своем аппарате.
 Тогда просто писал результаты, замечая
 Если все выведи правильно, то там и получится
 то экспериментом он владеет исключительно. Многие случаи
 видел в жизни, над которыми работал, хотя бы раз в жизни
 примерно малом виде этого

Своеобразным характером мышления Розенфельд всегда
 было видеть. Беседа с ним на научные темы. Он любил, когда кто-то
 рассказывал об опытах, но чтобы он слушал с интересом — а на его
 зательному лицу сразу было видно, слушает он с интересом или
 нет — надо было говорить только об основных фактах и выводах.
 вдалеке в технические подробности, которые Розенфельд не интересовали
 были. Когда мне приходилось приводить ему для утверждения чертежи
 импульсного генератора большой мощности для получения сильных
 магнитных полей, то он из вежливости шел перед собой и
 обращая внимание на то, что они лежали перед ним среди бумаг, и
 говорил: «Этот чертеж меня не интересует, вы просто учтите его
 только на тот случай, если машина работает. Основная идея изобретения
 — сделана очень быстро, с полуслова. Это меня поразило, ведь
 первые годы моего пребывания в Кембридже, когда надо было
 написать бумагу в газете или настоящие письма, что не мог
 писать с собой и сшить, и, несмотря на это, Розенфельд
 о своем деле и делал всегда очень интересные опыты
 прежде, чем рассказывать о своем опыте, машин
 идела и эксперименты. Он любил спрашивать до
 этого у него в дипломном курсе всегда бы
 писал карандашом. Он держал карандаш
 — очень удобным образом, и
 где держащей рукой, ру
 на стороне»

Fig. 13. A page of print recreated from a hologram using a coupled laser.

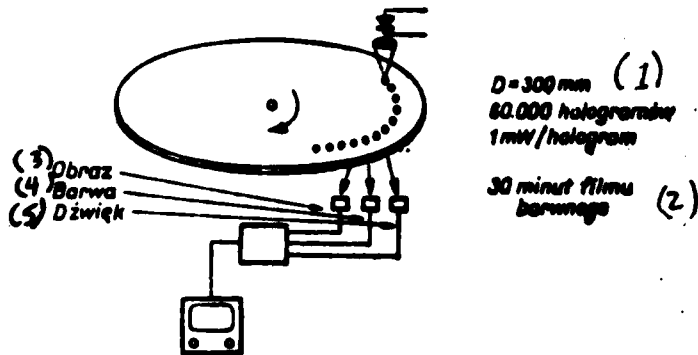

Fig. 14. Idealized diagram of a disc with visual holograms. 1 - D=300mm, 60 000 holograms, 1mW/hologram, 2 - 30 min of color film, 3 - image, 4 - color, 5 - sound.

A change in the information complex is realized by mechanical displacement of holograms. The choice of destination is carried out as previously by turning on appropriate laser. For a band containing 30 lasers operating in concert with a band of width 36 mm with 30 holograms of diameter 1 mm and capacity 10^4 bits each, the total memory capacity will be 3×10^{10} bits at band length of 10^2 m. If the holograms have small surface, then semiconductor lasers may be used to recreate images with analog information. Fig. 13 shows an image of a page of print recreated from a hologram of diameter 1 mm. The quality of this image is not worse than an image recreated using gas laser. Thus, coupled lasers can be used in image recording.

Fig. 14 shows a diagram of a disc with holograms containing visual information. The holographic recording system for images is distinguished by several advantages compared to binary recording. They include a considerably simpler system of path selection, a greater tolerance for accuracy of the mechanical system and, as a result, lower cost of the receiver. The hologram contains the information related to object illumination and its color, while another single-dimension hologram contains the sound track. A thirty-minute color and sound film can be recorded on a disc with diameter of 30 cm [14]. It is obvious that the best radiation source for this system is a coupled laser.

The present brief review contains a discussion of the application of coupled lasers to holographic memory only. The application of coupled lasers is much more extensive. They are used in optical communication systems, better logic elements can be constructed based on coupled lasers. Efforts are directed toward a design of integrated opto-electronic system on GaAs base. It seems that as technology advances, as the operational life of coupled lasers is increased, as

laser activity is obtained at new wavelengths, especially in the visible range, the coupled lasers will find ever wider application in opto-electronics. It also seems that most of the optical information processing systems will be constructed using these lasers.

References

1. N.G. Basov, W.H. Culver, B. Shab, *Applications of lasers to computers*, w: *Laser Handbook*, F.T. Arecchi, E.O. Schulz-Dubois (eds.), North Holland, Amsterdam 1972, t. 2, s. 1640-1693.
2. A.L. Mikaelian, W.I. Boriniew, *Golograficzne systemy pamieci*, *Radiotekhn. i Elektron.*, 19 (1974), s. 898-926.
3. H. Kiemle, *Considerations on holographic memories in the gigabyte region*, *Appl. Opt.*, 13 (1974), s. 803-807.
4. D. Pohl, *Stacked optical memories*, *Appl. Opt.*, 13 (1974), s. 341-346.
5. P.E. Twierdochleb, *Optyczne systemy pamieci z wyborkoj po sodiertaniju*, *Awtometrija*, nr 6 (1976), s. 3-14.
6. I.S. Gibin, M.A. Gofman, S.F. Kibiriew, P.E. Twierdochleb, *Izsladowanijs odnogo wariana gologrammnoj priznakowej pamieci*, *Awtometrija*, nr 6 (1976), s. 24-35.
7. N.G. Basov, W.W. Nikitin, W.D. Samojlow, G.I. Siemienow, *Optyczne pamieci na iniekcjonnych lazerach*, preprint FIAN, nr 83, 1975.
8. Ju M. Popow, *Primenenije poluprowodnikowych lazerow w sistemach optycznej pamieci*, w: *Semiconductor Sources of Electromagnetic Radiation*, M.A. Herman (ed.), PWN, Warszawa (1976), s. 521-542.
9. S.P. Kalasznikow, I.I. Klimow, W.W. Nikitin, G.I. Siemienow, *Zapis Fourier-gologramm izluczeniem impulsnych poluprowodnikowych lazerow*, *Kwant. Elektr.*, 1 (1977), s. 1666-1672.
10. W.N. Morozow, *Wosstanowlenije gologramm czasticzo kogierentnym izluczeniem*, *Kwant. Elektr.*, nr 5 (17) (1973), s. 5-13.
11. W.W. Nikitin, W.D. Samojlow, G.I. Siemienow, *Wlijanije paramietrow iniekcjonnych lazerow na wosstanowlenije fazowych gologramm*, *Kwant. Elektr.*, 1 (1974), s. 7-13.
12. M.A. Majorczuk, W.D. Samojlow, *Informacionnaja jemkost zapominajusczego ustrojstwa pri zapisi i szczywanii gologramm istocznikami s razlicznymi dlinami wozn izluczenia*, *Kwant. Elektr.*, 1 (1974), s. 609-614.
13. W.P. Karpielcew, W.D. Samojlow, *Wosstanowlenije mikrogologramm s tebejnoj informaczej s pomoszczju iniekcjonnych lazerow*, *Kwant. Elektr.*, 1 (1974), s. 162-168.
14. Y. Tsunoda, K. Tatsuno, K. Kataoka, Y. Takeda, *Holographic video disk: an alternative approach to optical video disks*, *Appl. Opt.*, 15 (1976), s. 1398-1403.

HOLOGRAPHIC MEMORY DEVICES WITH INJECTION LASERS

Summary

The article reviews problems connected with applications of injection lasers in constructions of the optoelectronic ROM memory. Principal optical requirements for lasers and holograms used in such devices are analysed. The analysis is supported by appropriate calculations and experimental results.

END

DATE
FILMED

5 81

DTIC