

MICROCOPY RESOLUTION TEST CHART

NATIONAL BUREAU OF STANDARDS-1963-A

LEVEL II

(11)

construction
engineering
research
laboratory



United States Army
Corps of Engineers
... Serving the Army
... Serving the Nation

TECHNICAL REPORT M-285

Mar 1981

Improved Roofing Materials & Systems

AD A 098 458

6
A STUDY OF CLIMATIC EFFECTS ON ROOF SYSTEMS
AT CAPE HATTERAS, NORTH CAROLINA.

9) Final rept.

14

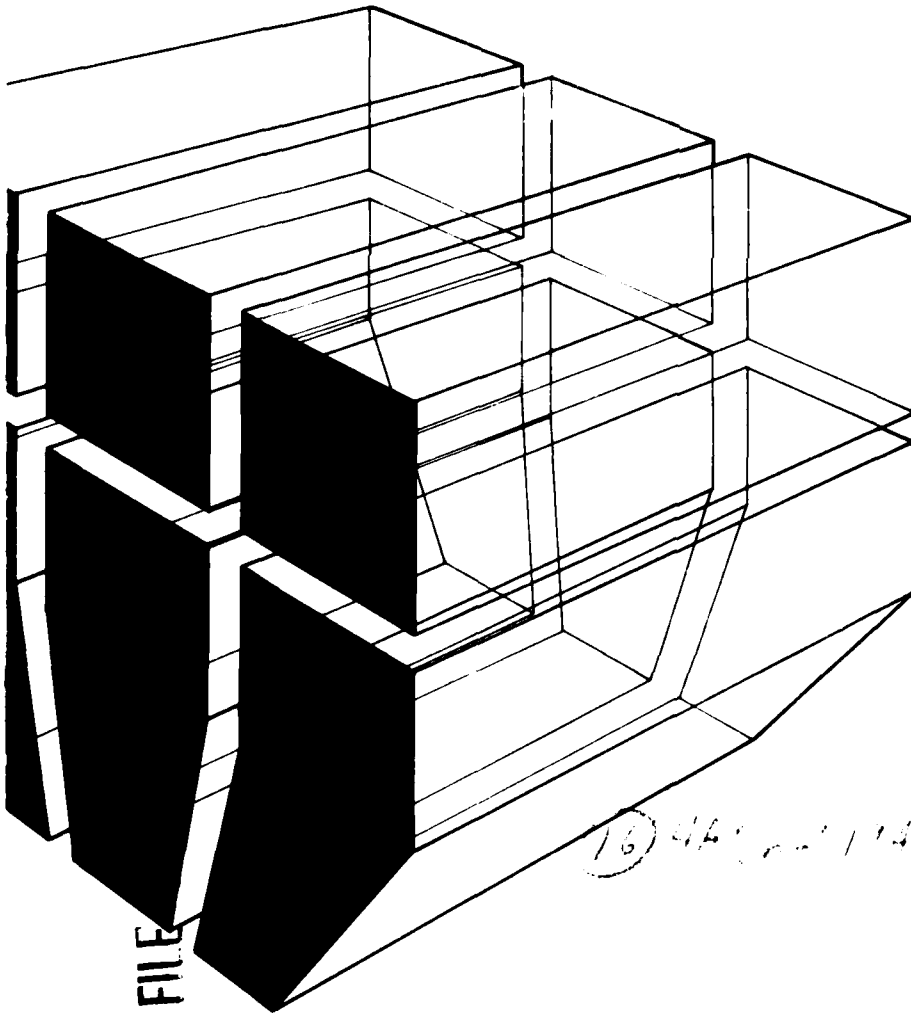

by
Barry J. Dempsey

13
14

DTIC
ELECTE
MAY 5 1981

A



DTIC FILE

Approved for public release; distribution unlimited.

81 5 04 124

The contents of this report are not to be used for advertising, publication, or promotional purposes. Citation of trade names does not constitute an official indorsement or approval of the use of such commercial products. The findings of this report are not to be construed as an official Department of the Army position, unless so designated by other authorized documents.

***DESTROY THIS REPORT WHEN IT IS NO LONGER NEEDED
DO NOT RETURN IT TO THE ORIGINATOR***

UNCLASSIFIED

SECURITY CLASSIFICATION OF THIS PAGE (When Data Entered)

REPORT DOCUMENTATION PAGE		READ INSTRUCTIONS BEFORE COMPLETING FORM
1. REPORT NUMBER CERL-TR-M-285	2. GOVT ACCESSION NO. AD-A098 458	3. RECIPIENT'S CATALOG NUMBER
4. TITLE (and Subtitle) A STUDY OF CLIMATIC EFFECTS ON ROOF SYSTEMS AT CAPE HATTERAS, NORTH CAROLINA		5. TYPE OF REPORT & PERIOD COVERED FINAL
		6. PERFORMING ORG. REPORT NUMBER
7. AUTHOR(s) BARRY J. DEMPSEY		8. CONTRACT OR GRANT NUMBER(s)
9. PERFORMING ORGANIZATION NAME AND ADDRESS U.S. ARMY CONSTRUCTION ENGINEERING RESEARCH LABORATORY P.O. Box 4005, Champaign, IL 61820		10. PROGRAM ELEMENT, PROJECT, TASK AREA & WORK UNIT NUMBERS 4A76271AT41-B-022
11. CONTROLLING OFFICE NAME AND ADDRESS		12. REPORT DATE March 1981
		13. NUMBER OF PAGES 101
14. MONITORING AGENCY NAME & ADDRESS (if different from Controlling Office)		15. SECURITY CLASS. (of this report) Unclassified
		15a. DECLASSIFICATION/DOWNGRADING SCHEDULE
16. DISTRIBUTION STATEMENT (of this Report) Approved for public release; distribution unlimited.		
17. DISTRIBUTION STATEMENT (of the abstract entered in Block 20, if different from Report)		
18. SUPPLEMENTARY NOTES Copies are obtainable from the National Technical Information Service Springfield, VA 22151		
19. KEY WORDS (Continue on reverse side if necessary and identify by block number) Cape Hatteras, NC roofs climate		
20. ABSTRACT (Continue on reverse side if necessary and identify by block number) A heat-transfer model was used to conduct a comprehensive study of nine composite roof systems for six building structures subjected to weather conditions at Cape Hatteras, NC. Based on analysis of the time-temperature regimes in the roof systems, numerous temperature and durability parameters were determined quantitatively. The durability parameters evaluated included the number of freeze-thaw cycles, rates of temperature change, lengths of freezing and thawing periods, and the range of temperature change. The thermal strains		

DD FORM 1 JAN 73 1473

EDITION OF 1 NOV 65 IS OBSOLETE

UNCLASSIFIED

SECURITY CLASSIFICATION OF THIS PAGE (When Data Entered)

UNCLASSIFIED

SECURITY CLASSIFICATION OF THIS PAGE(When Data Entered)

Block 20 continued.

in the various roofing layers were determined for unbonded interface conditions, and the transient heat flux was determined for the nine roof systems.

UNCLASSIFIED

SECURITY CLASSIFICATION OF THIS PAGE(When Data Entered)

FOREWORD

This project was performed for the Directorate of Military Programs, Office of the Chief of Engineers (OCE) under Project 4A76271AT41, "Military Facilities Engineering Technology"; Task B, "Facilities Operation and Maintenance"; Work Unit 022, "Improved Roofing Materials and Systems."

The work was performed by Dr. B. J. Dempsey, Consulting Engineer, Urbana, IL, for the Engineering and Materials Division (EM) of the U.S. Army Construction Engineering Research Laboratory (CERL), Champaign, IL. The project was done under Purchase Order DACA 88-79-M-0009, issued 20 October 1978, with Modification No. P00001, dated 2 November 1978.

Mr. John Ichter, DAEN-MPE-S, was the OCE Technical Monitor. Dr. Eugene Marvin and Mr. Myer Rosenfield were the CERL project coordinators.

Dr. R. Quattrone is Chief of CERL-EM. COL L. J. Circeo is Commander and Director of CERL, and Dr. L. R. Shaffer is Technical Director.

Accession For	
NTIS GRA&I	<input checked="" type="checkbox"/>
DTIC TAB	<input type="checkbox"/>
Unannounced	<input type="checkbox"/>
Justification	
Distribution/	
Availability Codes	
Avail and/or	
Dist	Special
A	

CONTENTS

	<u>Page</u>
DD FORM 1473	1
FOREWORD	3
LIST OF TABLES AND FIGURES	5
1 INTRODUCTION.....	11
Problem Statement	
Background	
Objective	
Approach	
Mode of Technology Transfer	
2 TESTING PROGRAM.....	14
3 DATA.....	16
4 ANALYSIS AND DISCUSSION.....	17
Temperature Effects	
Cooling and Warming Rates	
Length of Freezing and Thawing Periods	
Number of Freeze-Thaw Cycles	
Transient Heat Flux	
5 SUMMARY AND CONCLUSIONS.....	21
Summary	
Conclusions	
REFERENCES	23
TABLES	25
FIGURES	87
LIST OF ABBREVIATIONS	101
DISTRIBUTION	

TABLES

<u>Number</u>		<u>Page</u>
1	Average Temperature Above Freezing for Roof System 5, °F	25
2	Average Temperature Below Freezing for Roof System 5, °F	26
3	Average Cooling Rate for Roof System 5, °F/hr	27
4	Average Warming Rate for Roof System 5, °F/hr	28
5	Average Length of Freezing Period for Roof System 5, Days	29
6	Average Length of Thawing Period for Roof System 5, Days	30
7	Average Number of Freeze-Thaw Cycles for Roof System 5	31
8	Average Temperature Above Freezing for Roof System 18, °F	32
9	Average Temperature Below Freezing for Roof System 18, °F	33
10	Average Cooling Rate for Roof System 18, °F/hr	34
11	Average Warming Rate for Roof System 18, °F/hr	35
12	Average Length of Freezing Period for Roof System 18, Days	36
13	Average Length of Thawing Period for Roof System 18, °F	37
14	Average Number of Freeze-Thaw Cycles for Roof System 18	38
15	Average Temperature Above Freezing for Roof System 2, °F	39
16	Average Temperature Below Freezing for Roof System 2, °F	40
17	Average Cooling Rate for Roof System 2, °F/hr	41
18	Average Warming Rate for Roof System 2, °F/hr	42

TABLES (Cont'd)

<u>Number</u>		<u>Page</u>
19	Average Length of Freezing Period for Roof System 2, Days	43
20	Average Length of Thawing Period for Roof System 2, Days	44
21	Average Number of Freeze-Thaw Cycles for Roof System 2	45
22	Average Temperature Above Freezing for Roof System 3A, °F	46
23	Average Temperature Below Freezing for Roof System 3A, °F	47
24	Average Cooling Rate for Roof System 3A, °F/hr	48
25	Average Warming Rate for Roof System 3A, °F/hr	49
26	Average Length of Freezing Period for Roof System 3A, Days	50
27	Average Length of Thawing Period for Roof System 3A, Days	51
28	Average Number of Freeze-Thaw Cycles for Roof System 3A	52
29	Average Temperature Above Freezing for Roof System 3B, °F	53
30	Average Temperature Below Freezing for Roof System 3B, °F	54
31	Average Cooling Rate for Roof System 3B, °F/hr	55
32	Average Warming Rate for Roof System 3B, °F/hr	56
33	Average Length of Freezing Period for Roof System 3B, Days	57
34	Average Length of Thawing Period for Roof System 3B, Days	58
35	Average Number of Freeze-Thaw Cycles for Roof System 3B	59
36	Average Temperature Above Freezing for Roof System 4A, °F	60

TABLES (Cont'd)

<u>Number</u>		<u>Page</u>
37	Average Temperature Below Freezing for Roof System 4A, °F	61
38	Average Cooling Rate for Roof System 4A, °F/hr	62
39	Average Warming Rate for Roof System 4A, °F/hr	63
40	Average Length of Freezing Period for Roof System 4A, Days	64
41	Average Length of Thawing Period for Roof System 4A, Days	65
42	Average Number of Freeze-Thaw Cycles for Roof System 4A	66
43	Average Temperature Above Freezing for Roof System 4B, °F	67
44	Average Temperature Below Freezing for Roof System 4B, °F	68
45	Average Cooling Rate for Roof System 4B, °F/hr	69
46	Average Warming Rate for Roof System 4B, °F/hr	70
47	Average Length of Freezing Period for Roof System 4B, Days	71
48	Average Length of Thawing Period for Roof System 4B, Days	72
49	Average Number of Freeze-Thaw Cycles for Roof System 4B	73
50	Average Temperature Above Freezing for Roof System 34, °F	74
51	Average Temperature Below Freezing for Roof System 34, °F	75
52	Average Cooling Rate for Roof System 34, °F/hr	76
53	Average Warming Rate for Roof System 34, °F/hr	77
54	Average Length of Freezing Period for Roof System 34, Days	78

TABLES (Cont'd)

<u>Number</u>		<u>Page</u>
55	Average Length of Thawing Period for Roof Systems 34, Days	79
56	Average Number of Freeze-Thaw Cycles for Roof System 34, Days	80
57	Transient Heat Flux, Btu/hr-sq ft	81
58	Thermal Strains in Composite Roof Systems for Cape Hatteras, NC	83
59	Roof System Ranking in Relation to Computed Parameters	86

FIGURES

1	Roof System 5, Building 5, Cape Hatteras, NC	87
2	Roof System 18, Building 18, Cape Hatteras, NC	88
3	Roof System 2, Building 2, Cape Hatteras, NC	89
4	Roof System 3A, Building 3, Cape Hatteras, NC	90
5	Roof System 3B, Building 3, Cape Hatteras, NC	91
6	Roof System 4A, Building 4, Cape Hatteras, NC	92
7	Roof System 4B, Building 4, Cape Hatteras, NC	93
8	Roof System 34A, Building 34, Cape Hatteras, NC	94
9	Roof System 34B, Building 34, Cape Hatteras, NC	95
10	Idealized Freeze-Thaw Cycle for a Roof System	96
11	Average Cooling Rates for Roof Systems on Buildings 5, 18, and 2	96
12	Average Cooling Rates for Roof Systems on Buildings 3 and 4	97
13	Average Cooling Rates for Roof Systems on Building 34	97
14	Average Warming Rates for Roof Systems on Buildings 5, 18, and 2	98

FIGURES (Cont'd)

<u>Number</u>		<u>Page</u>
15	Average Warming Rates for Roof Systems on Buildings 3 and 4	98
16	Average Warming Rates for Roof Systems on Building 34	99
17	Average Number of Freeze-Thaw Cycles Per Year	99
18	Transient Heat Flux for Buildings 5, 18, 2, and 3	100
19	Transient Heat Flux for Buildings 4 and 34	100

A STUDY OF CLIMATIC EFFECTS ON ROOF SYSTEMS
AT CAPE HATTERAS, NORTH CAROLINA

1 INTRODUCTION

Problem Statement

Roofing systems currently used at military installations are generally short-lived for a variety of reasons. One major factor contributing to roof deterioration is the stress caused by the effects of climate (e.g., freeze-thaw cycles, exposure to temperature extremes, ultraviolet radiation, high winds, and hail).

Short-lived roofing has created unacceptably high life-cycle costs. For example, in FY78 the Government spent \$54 million on reroofing at military installations, and \$28 million during the first quarter of FY79. To help reduce these costs, the U.S. Army Construction Engineering Research Laboratory (CERL) is studying the effects of climate on several types of roofing systems in order to find which ones perform best under the various climatic stresses.

Background

The basic components of a composite roof system are the structural deck, vapor barrier, insulation, and built-up membrane. The structural deck and built-up membrane are common to all roof systems and are necessary for strength and weatherproofing. An insulating layer between the deck and membrane is being used more widely in modern roof construction to decrease heating and cooling costs. The vapor barrier is an impermeable membrane normally placed on the structural deck to prevent the flow of water vapor into the insulation or built-up membrane.

Brotherson¹ has discussed many causes of built-up roofing (BUR) failures. Griffin² has indicated that 10 to 15 percent of the built-up roofs in the United States fail prematurely. He has indicated that in severely cold regions, the incidence of roof problems exceeds the national average.

Climate greatly influences the performance of composite roof systems. Wrinkling, splitting, blistering, delamination, and alligating are a few of the climate-related distresses which can occur in the built-up membrane. Epstein and Putnam³ have indicated that cyclic freezing and thawing can

¹ D. E. Brotherson, "An Investigation into the Causes of Built-Up Roofing Failures," Research Report 61-2 (University of Illinois, October 1961), pp 1-10.

² C. W. Griffin, Manual of Built-Up Roof Systems (McGraw-Hill, 1970).

³ K. A. Epstein and L. E. Putnam, "Performance Criteria for the Protected Membrane Roof Systems," Proceedings of the Symposium on Roofing Technology (National Bureau of Standards and National Roofing Contractors Association, September 1977), pp 49-60.

increase water absorption in insulating material and reduce thermal resistance. Lee, Dupuis, and Johnson⁴ and Cash⁵ have noted that thermally generated stresses can develop in built-up roof systems as a result of temperature changes. Cracking and deterioration of concrete as a result of freeze-thaw action is well documented. The accumulation of water often contributes to problems of durability in composite roof systems. Water vapor tends to diffuse through composite roof systems from a warm, humid interior to a cold, dry exterior. Laaly⁶ has indicated that freeze-thaw cycles decreased the strength of immersed, asphalt-based, built-up membranes from 14 to 19 percent of dry strength for one cycle to 11 percent for 10 cycles.

Griffin⁷ has indicated that there are appropriate American Society for Testing and Materials (ASTM) and Federal standards for testing important properties of component materials such as the surfacing aggregates, felts, bitumens, insulation, vapor barriers, and structural decks used in roofing systems. However, he states that there are no generally accepted tests for performance of composite roof systems assembled from these components. For performance evaluation of composite roof systems, researchers recommend either modifying existing tests or developing new tests.

It is apparent that the temperature regime must be quantitatively characterized if the service life and performance of composite roof systems are to be predicted for a given climate. This report describes development of quantitative temperature parameters obtained through a theoretical heat-transfer model and the application of these parameters to evaluating the durability of composite roof systems.

These parameters are used to theoretically analyze the effects of the climate at Cape Hatteras on heat loss through building roofs. Three of the roofs included in this study are being built at each of three Army installations in CONUS. Behavior of these roofs will be monitored for 2 years and the results compared to the theoretical predictions.

Objective

The objective of this study is to analyze the influence of climate on the durability and performance of nine different roof systems at Cape Hatteras, NC.

⁴ J. W. Lee, R. M. Dupuis, and J. E. Johnson, "Experimental Determination of Temperature Induced Loads in BUR Systems," Proceedings of the Symposium on Roofing Technology (National Bureau of Standards and National Roofing Contractors Association, September 1977), pp 38-48.

⁵ C. G. Cash, "Thermal Warp-A Hypothesis for Built-Up Roofing Splitting Failures," Roofing Systems, Special Technical Publication 603 (American Society for Testing Materials [ASTM] 1976), pp 114-131.

⁶ H. O. Laaly, "Effects of Moisture and Freeze-Thaw Cycles on the Strength of Bituminous Built-Up Roofing Membranes," Proceedings of the Symposium on Roofing Technology (National Bureau of Standards and National Roofing Contractors Association, September 1977), pp 244-251.

⁷ C. W. Griffin, Manual of Built-Up Roof Systems (McGraw-Hill, 1970).

Approach

The specific tasks performed in this study were:

1. Determining the temperature variation in the roof sections as a function of time and position
2. Quantitatively determining the pertinent temperature parameters in the various layers of the roof sections
3. Evaluating the thermal strain in the roofing layers
4. Determining the transient heat flux through the roof sections
5. Comparing the relative durabilities and performance levels of the roof systems
6. Providing recommendations for laboratory and field testing to verify roof performance in different climatic zones.

Mode of Technology Transfer

Technology transfer will be accomplished by preparation of new or revised military construction guide specifications for the types of roofs selected.

2 TESTING PROGRAM

Based on previous work by Dempsey⁸ a finite-difference, heat-transfer model was used to compute the temperature regime and transient heat flux as a function of time for nine roof systems. In the transient heat-transfer model, the energy balance for an increment of time is expressed as:

$$\begin{array}{l} \text{Heat added to a} \\ \text{nodal volume} \end{array} + \begin{array}{l} \text{Heat given up by} \\ \text{a nodal volume} \end{array} + \begin{array}{l} \text{Heat stored in a} \\ \text{nodal volume} \end{array}$$

The roof systems at Cape Hatteras were analyzed for Buildings 5, 18, 2, 3, 4, and 34, and identified according to building number and section thickness as 5, 12, 2, 3A, 3B, 4A, 4B, 34A, and 34B. Figures 1 through 9 show the representative composite roof systems studied, including the physical and thermal properties of the various roofing layers. The surface boundary temperatures of the roof systems were determined from climatic data and included meteorological parameters such as short-wave radiation, long-wave radiation, convection, and air temperature. Ten years of climatic data (July 1, 1967 through June 30, 1977) from Cape Hatteras, NC, were used as input. The boundary temperatures at the bottom of the roof systems were related to the expected interior room temperatures shown in Figures 1 through 9.

The literature provides a more comprehensive discussion of the heat transfer model's capabilities and validation.⁹

In previous work on roof systems, Dempsey¹⁰ has indicated that the temperature parameters pertinent to durability and performance are:

- ⁸ B. J. Dempsey, A Heat-Transfer Model for Evaluating Frost Action and Temperature Related Effects in Multilayered Pavement Systems, Ph.D. Thesis (University of Illinois, 1969); B. J. Dempsey, "Quantitative Freezing and Thawing Parameters for Composite Roof Decks," ASTM Proceedings, First International Conference on Durability of Building Materials and Components (ASTM, 1978).
- ⁹ B. J. Dempsey, Ph.D. Thesis; B. J. Dempsey, "Quantitative Freezing and Thawing Parameters for Composite Roof Decks"; M. R. Thompson and B. J. Dempsey, "Quantitative Characterization of Cyclic Freezing and Thawing in Stabilized Pavement Materials," Highway Research Record 304 (Highway Research Board, 1970) pp 38-44; B. J. Dempsey and M. R. Thompson, "A Heat-Transfer Model for Evaluating Frost Action and Temperature Related Effects in Multilayered Pavement Systems," Highway Research Record 342 (Highway Research Board, 1970), pp 39-56; C. R. Marek and B. J. Dempsey, "A Model Utilizing Climatic Factors for Determining Stresses and Deflections in Flexible Pavement Systems," Proceedings (The Third International Conference on the Structural Design of Asphalt Pavements, London, England, September 1972), pp 101-114; B. J. Dempsey and M. R. Thompson, "Effects of Freeze-Thaw Parameters on the Durability of Stabilized Materials," Highway Research Record 379 (Highway Research Board, 1972), pp 10-18.
- ¹⁰ B. J. Dempsey, "Quantitative Freezing and Thawing Parameters to Composite Roof Decks."

1. Cooling rate
2. Temperature below freezing
3. Length of freezing period
4. Warming rate
5. Temperature above freezing
6. Length of thawing period
7. Number of freezing and thawing periods
8. Temperature variability

Figure 10 shows an idealized freeze-thaw cycle for a roof system. The quantitative parameters for the idealized freeze-thaw cycle are dependent on the geographical location, month in the freezing period, year, and location in the composite roof system. The freeze-thaw history at a selected point in the roof system can be simulated by developing an idealized freeze-thaw cycle for each winter month for a chosen number of years of climatic data and determining the number of freeze-thaw cycles that occurred during each month. Dempsey¹¹ has shown that statistical analyses of such data provide satisfactory information for quantitative characterization of the freeze-thaw environment. Furthermore, the data are valuable input for laboratory testing procedures when it is desirable to simulate field conditions.¹²

¹¹B. J. Dempsey, "Quantitative Freezing and Thawing Parameters for Composite Roof Decks."

¹²B. J. Dempsey, "A Programmed Freeze-Thaw Durability Testing Unit for Evaluating Paving Materials," Journal of Materials, Vol 7, No. 2 (ASTM, June 1972), pp 143-147.

3 DATA

Tables 1 through 7 show temperature parameter data for various layers and depths of Building 5's roof system for 10 years of climatic input. The data include average temperature above freezing, average temperature below freezing, average cooling rate, average warming rate, average length of freezing period, average length of thawing period, and average number of freeze-thaw cycles. The data are statistically summarized over the 10-year study period for each month and for the year.

In a similar manner, Tables 8 through 56 provide the data for roof systems 18, 2, 3A, 3B, 4A, 4B, 34A, and 34B.

Table 57 presents the transient heat flux for the nine roof systems. These data are also statistically summarized over the 10-year study period for each month and for the year.

4 ANALYSIS AND DISCUSSION

Temperature Effects

Tables 1, 8, 15, 22, 29, 36, 43, and 50 present temperature data in the roofing systems for conditions above freezing. Tables 2, 9, 16, 23, 30, 37, 44, and 51 provide temperature data for conditions below freezing.

Analysis of the data indicates that the freezing gradient generally does not penetrate below the surface layer of the roof systems in Cape Hatteras. The freezing gradient was found to penetrate the existing built-up layer on Building 18 as well as the gravel layers in roof systems 3A, 3B, 4A, and 4B. There was also some penetration of the freezing gradient into the built-up layer in roof systems 3A and 3B; however, the underlying insulation layers in all of the roof systems were highly effective in preventing deeper penetration of the freezing gradients.

The temperature above freezing generally varied with time of year and depth in the roof system. The data indicated that the temperature variability for a specified month for the 10 years of climatic input was not large. The temperatures in the deeper layers of the roof systems were fairly uniform, since they were controlled by the building's interior room temperature.

Temperature variations can influence the thermal strain experienced by roofing layers. Table 58 shows thermal strains in the nine roof systems for temperature variations of plus and minus three standard deviations from the mean temperature for 10 years of climatic data. The thermal strains in Table 58 are computed for a condition of no bonding or restraint between roof system layers.

Analysis of the data indicates that the thermal strains in the GAF mineral shield on Building 4 (roof systems 4A and 4B) and the Ethylene Propylene Diene Monomer (EPDM) membrane on Building 34 (roof systems 34A and 34B) are reasonably larger. The 25-mil diathon coating on Building 5 and the 40-mil Gacoflex membrane on Building 18 also experience relatively large thermal strains. The probability of thermal cracking in these materials will depend on their stress-strain properties at various temperatures. Thermal strains may become more evident in these materials as they age and become less ductile.

The built-up layer in roof systems 18, 3A, and 3B may also be susceptible to thermal cracking. The layer of surface gravel in roof systems 3A and 3B has little influence on the temperature variability in the built-up layer.

Table 58 indicates that insulation layers are highly beneficial in decreasing temperature variability and, therefore, the thermal strain in composite roof systems. The data validate the benefits of the protected membrane

roof (PMR) concept discussed by Larsson, Ondrus, and Petersson.¹³ In the PMR concept, the roofing membrane layer is sandwiched between the deck below and the insulation above. For the membrane, the PMR concept offers drastic reduction in temperature ranges (thermal strain) and protection from chemicals, radiation, and physical hazards.

Cooling and Warming Rates

Tables 3, 10, 17, 24, 31, 38, 45, and 52 provide data for cooling rates in the composite roof systems. Tables 4, 11, 18, 25, 32, 39, 46, and 53 present the warming rate data.

Generally, the time of year did not greatly influence the cooling rate at specified depths in a given roof system. Except for Building 18, the surface cooling rate generally varied from about 2.0°F/hr (1.11°C/hr) to 2.5°F/hr (1.39°C/hr). The surface cooling rate for Building 18 varied from about 1.5°F/hr (0.83°C/hr) to 2.0°F/hr (1.11°C/hr).

The cooling rates were found to decrease with depth in the roof system and the type of layer material. Figures 11, 12, and 13 show the average annual cooling rates for the nine roof systems as a function of section depth.

Roof systems 5, 18, 2, 3A, 4A, 34A, and 34B experienced rather rapid decreases in the cooling rate as the section depth increased. It is interesting to note that the thicker roof systems (3B and 4B) showed a slower decrease in cooling rate with depth. Figure 12 indicates that increasing the thickness of the insulation layers in roof systems 3B and 4B did not substantially reduce the surface cooling rate from that shown for roof systems 3A and 4A.

The lower cooling rates noted for Building 18 (Figure 2) may be caused partly by the bright white surface of the Gacoflex and the higher interior room temperature of 85°F (29.4°C).

Except for the magnitude of the values, the warming rates shown in Tables 4, 11, 18, 25, 32, 39, 46, and 53 displayed the same trends as the cooling rates. Figures 14, 15, and 16 indicate that the annual warming rate was greatest at the surface of the roofing systems and decreased with depth in the sections. The surface warming rate varied from about 4.0°F/hr (2.22°C/hr) to 5.0°F/hr (2.78°C/hr) for all roof systems except on Building 18, which was about 3.5°F/hr (1.94°C/hr).

The significance of the effect of cooling and warming rates on roof systems may be how they influence the thermal strain rate. It is evident that with larger cooling and warming rates at the roof surface, materials at the surface would experience faster strain rates than materials deeper in the section, where cooling and warming rates are smaller.

¹³L. E. Larsson, J. Ondrus, B. Petersson, "The Protected Membrane Roof (PMR) - A Study Combining Field and Laboratory Tests," Proceedings of the Symposium on Roofing Technology (National Bureau of Standards and National Roofing Contractors Association, September 1977), pp 86-92.

Insulating layers helped decrease the rate of temperature change for both cooling and warming conditions. It would seem that the membrane protection of insulating layers can be effective in decreasing roof system durability failures. An additional benefit derived from insulation layers is moderation of the differential thermal strains occurring in the roofing layers as a result of differences in temperature, cooling rate, and warming rate.

Length of Freezing and Thawing Periods

Tables 5, 12, 19, 26, 33, 40, 47, and 54 present the average length of the thawing period in the roof systems during freeze-thaw cycles. Similarly, Tables 6, 13, 20, 27, 34, 41, 48, and 55 show the average length of the freezing period. Freezing is assumed to occur at 31°F (-0.5°C) in this study. The data indicate that freezing and thawing are generally confined to the surface layers of the roof systems. The average durations of the freezing periods are very short and indicate the influence of diurnal winter temperatures on roof system durability. Most of the freezing and thawing occurs during the winter months of December, January, February, and March. The duration of the freezing period increases, and the duration of the thawing period decreases during the colder months of January and February, indicating the larger number of freeze-thaw cycles which occur at that time. Freezing periods of short duration are probably less detrimental to the roofing layers than those of long duration because less moisture transfer results from freezing gradients and therefore less ice accumulates in the layers.

Number of Freeze-Thaw Cycles

Tables 7, 14, 21, 28, 35, 42, 49, and 56 show the number of freeze-thaw cycles in the roof systems. Figure 17 summarizes the average annual number of freeze-thaw cycles at various depths in the roof systems on the different buildings. As noted in the tables and in Figure 17, most freeze-thaw cycles occurred at the surface (0.0 in. [0.0 cm]) of the roof systems. The built-up roofing layers on Buildings 18 and 3 (roof systems 3A and 3B) also experienced cyclic freeze-thaw action at depths of 0.5 in. (1.27 cm) and 1.0 in. (2.54 cm). Some freeze-thaw cycles are noted in the insulating layers of roof systems 4A and 4B. It is apparent that the gravel surface layers on roof systems 3A and 3B have little insulating value to freeze-thaw temperatures. In all of the roofing systems, 1 to 2 in. (2.54 to 5.08 cm) of insulation were adequate for preventing cyclic freeze-thaw action.

Epstein and Putnam¹⁴ have indicated that insulation must be resistant to water and to freeze-thaw action. They found that water absorption by various insulations after freeze-thaw exposure could range from less than 10 percent to more than 80 percent during a 10-year period. They also indicated that 500 to 700 freeze-thaw cycles would be a conservative estimate for most locations during a typical 10-year period. Figure 17 shows that the upper roofing

¹⁴K. A. Epstein and L. E. Putnam, "Performance Criteria for the Protected Membrane Roof Systems," Proceedings of the Symposium on Roofing Technology (National Bureau of Standards and National Roofing Contractors Association, September, 1977), pp 49-60.

layers at Cape Hatteras would experience an average of 200 to 600 freeze-thaw cycles during a 10-year period. As shown in Tables 7, 14, 21, 28, 35, 42, 49, and 56, the number of freeze-thaw cycles over a 10-year period at $\bar{X} + 3\sigma$ would range from about 200 to 900.

Cyclic freezing and thawing could have detrimental effects on the durability of built-up roofing layers on Buildings 18 and 3, as well as on the three-ply GAF mineral shield layer on Building 4. It is important to use durable materials at the surface of roof systems so that splitting, blistering, delamination, alligatoring, and other durability failures can be minimized. The smaller number of freeze-thaw cycles noted at the roof surface on Building 18 is caused partly by the higher interior room temperature of 85°F (29.4°C) (see Figure 17).

Transient Heat Flux

Table 57 presents the transient heat flux for the roof systems studied. Figures 18 and 19 show the average heat flux for each month analyzed. As expected, heat was transferred into the roof system during the summer and out of the roof system during the winter.

Roof systems 5, 4B, 34A, and 34B displayed the lowest flux values in both winter and summer weather. Roof systems 18, 2, and 3A showed high values of heat flux. Roof systems 3B and 4A displayed intermediate flux values. The large flux loss noted for Building 18 (Figure 2) was probably influenced by the 85°F (29.4°C) interior temperature used in the analysis. However, the 80°F (26.7°C) interior temperature used in the analysis of Building 5 (Figure 1) did not cause a large flux loss. The greater insulation thickness and the 1 in. (2.54 cm) of gypsum concrete improved the thermal efficiency of Building 5 over that of Building 18. Although the roof system on Building 2 is very deep, Figure 18 shows that the heat flux is large in both summer and winter. This would indicate that the thermal efficiency of a roofing system is not always a function of total thickness, but that it is a function of layer combinations, type of insulation, layer thickness, and temperature differentials.

5 SUMMARY AND CONCLUSIONS

Summary

In previous work, Dempsey¹⁵ has found that freeze-thaw cycles, cooling rate, freezing period, and freezing temperature were the most important parameters affecting the durability of roofing materials. These parameters are important, since it is the combination of a slow cooling or freezing rate and freeze-thaw cycles that often causes moisture buildup and associated durability problems in the various roofing layers. In addition, the rate of temperature change and the magnitude of temperature can be expected to influence the rate and magnitude of strain.

Table 59 ranks the roof systems in relation to the computed parameters. In terms of freeze-thaw cycles, the roof systems with surface layers of aggregate displayed fewer numbers of freeze-thaw cycles and therefore should provide better durability properties.

The lower the cooling rate is, the higher is the potential of moisture transfer; thus, more damage can occur.

When evaluated alone, the length of the freezing period is not a major influence on roof performance; however, it does contribute to the freeze-thaw durability.

The thermal strain in the upper layers of the roof systems is an important temperature parameter influencing roof performance. Roof systems having an insulation layer beneath an aggregate layer displayed the lowest thermal strains (Table 58).

The thermal efficiency of the roof structures is based on the heat flux during the year. The magnitude of the heat flux appears to be controlled by factors other than insulation layer thickness and roof system thickness. In transient heat-transfer analysis, it is evident that the heat storage capabilities of the layers are also important in determining the magnitude of the heat flux gained or lost through the roof system.

In summary, the performance of the roof systems analyzed in this study appear to depend on how well they resist the climate parameters which cause distress.

Conclusions

The following conclusions have been drawn from this study:

¹⁵B. J. Dempsey, "Quantitative Freezing and Thawing Parameters for Composite Roof Decks," ASTM Proceedings, First International Conference on Durability of Building Materials and Components (ASTM, 1978).

1. Materials of high quality and durability are required at the roof surface because of the temperature variability and freeze-thaw action which occur there.

2. Insulating materials help moderate the rate and magnitude of temperature changes in roof systems; however, insulation may increase the severity of climatic effects on surface membranes.

3. The data obtained in this study showed that membrane roofs in which the roofing membrane layer is sandwiched between the deck below and the insulation above are subjected to fewer freeze-thaw cycles and less thermal strain.

4. Transient heat flux in composite roof systems is related to layer thickness, layer thermal properties, and layer physical properties. Total roof thickness alone is not indicative of thermal efficiency.

REFERENCES

- Brotherson, D. E., "An Investigation into the Causes of Built-Up Roofing Failures," Research Report 61-2 (University of Illinois, October 1961), pp 1-10.
- Cash, C. G., "Thermal Warp - A Hypothesis for Built-Up Roofing Splitting Failures," Roofing Systems, Special Technical Publication 603 Symposium (American Society for Testing and Materials [ASTM], 1976) pp 114-131.
- Dempsey, B. J., A Heat-Transfer Model for Evaluating Frost Action and Temperature Related Effects in Multilayered Pavement Systems, Ph.D. Thesis (University of Illinois, 1969).
- Dempsey, B. J., "Quantitative Freezing and Thawing Parameters for Composite Roof Decks," ASTM Proceedings, First International Conference on Durability of Building Materials and Components (ASTM, Special Technical Publication 691, 1980).
- Dempsey, B. J., and M. R. Thompson, "A Heat-Transfer Model for Evaluating Frost Action and Temperature Related Effects in Multilayered Pavement Systems," Highway Research Record 342 (Highway Research Board, 1970), pp 39-56.
- Dempsey, B. J., and M. R. Thompson, "Effects of Freeze-Thaw Parameters on the Durability of Stabilized Materials," Highway Research Record 379 (Highway Research Board, 1972), pp 10-18.
- Dempsey, B. J., "A Programmed Freeze-Thaw Durability Testing Unit for Evaluating Paving Materials," Journal of Materials, Vol 7, No. 2, (ASTM, June 1972), pp 143-147.
- Epstein, K. A., and L. E. Putnam, "Performance Criteria for the Protected Membrane Roof Systems," Proceedings of the Symposium on Roofing Technology (National Bureau of Standards and National Roofing Contractors Association, September 1977), pp 49-60.
- Griffin, C. W., Manual of Built-Up Roof Systems (McGraw-Hill, 1970).
- Laaly, H. O., "Effects of Moisture and Freeze-Thaw Cycles on the Strength of Bituminous Built-Up Roofing Membranes," Proceedings of the Symposium on Roofing Technology (National Bureau of Standards and National Roofing Contractors Association, September 1977), pp 244-251.
- Larsson, L. E., J. Ondrus, and B. Petersson, "The Protected Membrane Roof (PMR) - A Study Combining Field and Laboratory Tests," Proceedings of the Symposium on Roofing Technology (National Bureau of Standards and National Roofing Contractors Association, September 1977), pp 86-92.
- Lee, J. W., R. M. Dupuis, and J. E. Johnson, "Experimental Determination of Temperature Induced Loads in BUR Systems," Proceedings of the Symposium on Roofing Technology (National Bureau of Standards and National Roofing Contractors Association, September 1977), pp 38-48.

Marek, C. R., and B. J. Dempsey, "A Model Utilizing Climatic Factors for Determining Stresses and Deflections in Flexible Pavement Systems," Proceedings (The Third International Conference on the Structural Design of Asphalt Pavements, London, England, September 1972), pp 101-114.

Thompson, M. R., and B. J. Dempsey, "Quantitative Characterization of Cyclic Freezing and Thawing in Stabilized Pavement Materials," Highway Research Record 304 (Highway Research Board, 1970), pp 38-44.

Table 1

Average Temperature Above Freezing for Roof System 5, °F

Building Identification		5			
Roofing Layer		25 mil Diathon	Polyurethane Foam	Gypsum Concrete	Gypsum Plank
Depth in Section (in.)		0.0	1.0	3.0	4.0
July	\bar{X}	97.00	88.93	81.16	80.53
	σ	2.63	1.43	0.24	0.13
	V, %	2.71	1.61	0.30	0.16
August	\bar{X}	94.11	87.36	81.03	80.47
	σ	3.32	1.83	0.34	0.18
	V, %	3.53	2.09	0.42	0.23
September	\bar{X}	84.17	82.07	80.14	80.04
	σ	3.11	1.78	0.35	0.21
	V, %	3.69	2.17	0.44	0.26
October	\bar{X}	74.53	76.84	79.12	79.53
	σ	1.34	0.78	0.18	0.13
	V, %	1.80	1.02	0.22	0.16
November	\bar{X}	61.11	68.15	77.33	78.63
	σ	1.90	1.54	0.33	0.17
	V, %	3.00	2.27	0.43	0.21
December	\bar{X}	57.14	63.84	76.46	78.20
	σ	2.18	1.66	0.33	0.20
	V, %	3.82	2.60	0.44	0.25
January	\bar{X}	55.04	60.16	75.70	77.82
	σ	1.83	1.16	0.25	0.15
	V, %	3.33	1.93	0.33	0.20
February	\bar{X}	59.05	62.62	76.18	78.05
	σ	4.10	1.94	0.39	0.20
	V, %	6.95	3.10	0.51	0.26
March	\bar{X}	63.57	67.18	77.08	78.50
	σ	3.71	1.81	0.36	0.20
	V, %	5.83	2.70	0.46	0.26
April	\bar{X}	70.61	73.70	78.26	79.09
	σ	1.62	1.16	0.26	0.18
	V, %	2.30	1.57	0.33	0.22
May	\bar{X}	81.04	79.63	79.26	79.58
	σ	1.72	0.98	0.22	0.13
	V, %	2.12	1.23	0.28	0.16
June	\bar{X}	89.92	84.78	80.26	80.08
	σ	1.49	0.79	0.11	0.06
	V, %	1.66	0.93	0.14	0.08
Year	\bar{X}	75.35	74.68	78.51	79.22
	σ	0.87	0.39	0.09	0.10
	V, %	1.15	0.53	0.11	0.12

$$^{\circ}\text{C} = (^{\circ}\text{F} - 32)/1.8$$

Table 2

Average Temperature Below Freezing for Roof System 5, °F

Building Identification		5			
Roofing Layer		25 mil Diathon	Polyurethane Foam	Gypsum Concrete	Gypsum Plank
Depth in Section (in.)		0.0	1.0	3.0	4.0
July	\bar{X} σ V, %	---	---	---	---
August	\bar{X} σ V, %	---	---	---	---
September	\bar{X} σ V, %	---	---	---	---
October	\bar{X} σ V, %	---	---	---	---
November	\bar{X} σ V, %	26.53 3.49 13.16	---	---	---
December	\bar{X} σ V, %	28.00 1.16 4.15	---	---	---
January	\bar{X} σ V, %	25.14 2.74 10.89	---	---	---
February	\bar{X} σ V, %	25.55 2.22 8.69	---	---	---
March	\bar{X} σ V, %	26.20 1.21 4.62	---	---	---
April	\bar{X} σ V, %	27.99 0.00 0.00	---	---	---
May	\bar{X} σ V, %	---	---	---	---
June	\bar{X} σ V, %	---	---	---	---
Year	\bar{X} σ V, %	25.98 1.06 4.09	---	---	---

$^{\circ}\text{C} = (^{\circ}\text{F} - 32)/1.8$

Table 3

Average Cooling Rate for Roof System 5, °F/hr

Building Identification		5			
Roofing Layer		25 mil Diathon	Polyurethane Foam	Gypsum Concrete	Gypsum Plank
Depth in Section (in.)		0.0	1.0	3.0	4.0
July	\bar{X}	1.98	1.06	0.29	0.13
	σ	0.16	0.09	0.03	0.02
	V, %	8.27	8.48	9.64	13.11
August	\bar{X}	2.11	1.13	0.27	0.08
	σ	0.24	0.13	0.04	0.01
	V, %	11.23	11.42	13.59	13.99
September	\bar{X}	2.35	1.23	0.15	0.08
	σ	0.18	0.10	0.01	0.01
	V, %	7.76	7.78	9.24	7.33
October	\bar{X}	2.27	1.16	0.13	0.07
	σ	0.17	0.09	0.01	0.01
	V, %	7.48	7.49	6.43	7.90
November	\bar{X}	2.22	1.13	0.12	0.06
	σ	0.17	0.09	0.01	0.01
	V, %	7.72	7.68	8.35	8.05
December	\bar{X}	2.08	1.05	0.12	0.06
	σ	0.16	0.08	0.01	0.00
	V, %	7.61	7.71	8.31	7.97
January	\bar{X}	2.08	1.05	0.12	0.06
	σ	0.15	0.08	0.01	0.00
	V, %	7.24	7.27	5.07	7.33
February	\bar{X}	2.34	1.19	0.14	0.07
	σ	0.29	0.15	0.02	0.01
	V, %	12.40	12.39	11.70	12.60
March	\bar{X}	2.58	1.33	0.17	0.08
	σ	0.20	0.11	0.01	0.01
	V, %	7.94	7.93	8.77	7.68
April	\bar{X}	2.45	1.30	0.23	0.08
	σ	0.16	0.09	0.01	0.01
	V, %	6.51	6.58	4.94	7.69
May	\bar{X}	2.24	1.20	0.31	0.11
	σ	0.10	0.05	0.02	0.01
	V, %	4.28	4.39	5.06	8.23
June	\bar{X}	2.03	1.09	0.30	0.15
	σ	0.14	0.07	0.02	0.01
	V, %	6.81	6.86	7.18	7.22
Year	\bar{X}	2.23	1.16	0.18	0.08
	σ	0.06	0.03	0.01	0.00
	V, %	2.65	2.65	3.10	2.95

$$^{\circ}\text{C/hr} = (^{\circ}\text{F/hr})/1.8$$

Table 4

Average Warming Rate for Roof System 5, ⁵F

Building Identification		5			
Roofing Layer		25 mil Diathon	Polyurethane Foam	Gypsum Concrete	Gypsum Plank
Depth in Section (in.)		0.0	1.0	3.0	4.0
July	\bar{X}	4.86	2.82	0.27	0.13
	σ	0.44	0.26	0.03	0.01
	V, %	9.01	9.25	9.25	8.09
August	\bar{X}	5.24	2.92	0.25	0.16
	σ	0.65	0.37	0.03	0.02
	V, %	12.51	12.64	11.84	9.82
September	\bar{X}	5.12	2.34	0.33	0.17
	σ	0.44	0.19	0.02	0.01
	V, %	8.67	7.97	6.37	7.99
October	\bar{X}	2.66	1.52	0.29	0.15
	σ	0.20	0.11	0.03	0.01
	V, %	7.52	7.48	8.85	7.32
November	\bar{X}	2.62	1.49	0.27	0.14
	σ	0.21	0.12	0.02	0.01
	V, %	8.10	8.11	7.85	8.20
December	\bar{X}	2.42	1.38	0.23	0.13
	σ	0.16	0.09	0.02	0.01
	V, %	6.69	6.62	7.52	8.38
January	\bar{X}	2.38	1.36	0.23	0.13
	σ	0.18	0.10	0.02	0.01
	V, %	7.57	7.57	9.64	8.69
February	\bar{X}	2.81	1.60	0.29	0.16
	σ	0.41	0.23	0.04	0.02
	V, %	14.66	14.54	14.88	14.07
March	\bar{X}	4.26	2.04	0.34	0.18
	σ	0.41	0.18	0.03	0.02
	V, %	9.69	8.80	9.09	8.60
April	\bar{X}	6.03	3.17	0.29	0.20
	σ	0.35	0.19	0.02	0.01
	V, %	5.84	5.94	7.71	6.24
May	\bar{X}	5.54	3.18	0.29	0.16
	σ	0.27	0.16	0.01	0.00
	V, %	4.91	5.03	4.89	3.21
June	\bar{X}	5.01	2.91	0.29	0.13
	σ	0.38	0.22	0.02	0.01
	V, %	7.49	7.61	7.66	7.54
Year	\bar{X}	4.08	2.23	0.28	0.15
	σ	0.11	0.06	0.01	0.00
	V, %	2.79	2.67	2.50	2.55

$$^{\circ}\text{C/hr} = (^{\circ}\text{F/hr})/1.8$$

Table 5

Average Length of Freezing Period for Roof System 5, Days

Building Identification		5			
Roofing Layer		25 mil Diathon	Polyurethane Foam	Gypsum Concrete	Gypsum Plank
Depth in Section (in.)		0.0	1.0	3.0	4.0
July	\bar{X}	---	---	---	---
	σ	---	---	---	---
	V, %	---	---	---	---
August	\bar{X}	---	---	---	---
	σ	---	---	---	---
	V, %	---	---	---	---
September	\bar{X}	---	---	---	---
	σ	---	---	---	---
	V, %	---	---	---	---
October	\bar{X}	---	---	---	---
	σ	---	---	---	---
	V, %	---	---	---	---
November	\bar{X}	0.10	---	---	---
	σ	0.09	---	---	---
	V, %	90.97	---	---	---
December	\bar{X}	0.12	---	---	---
	σ	0.04	---	---	---
	V, %	32.18	---	---	---
January	\bar{X}	0.21	---	---	---
	σ	0.08	---	---	---
	V, %	38.49	---	---	---
February	\bar{X}	0.16	---	---	---
	σ	0.05	---	---	---
	V, %	29.21	---	---	---
March	\bar{X}	0.12	---	---	---
	σ	0.03	---	---	---
	V, %	22.64	---	---	---
April	\bar{X}	0.02	---	---	---
	σ	0.04	---	---	---
	V, %	200.00	---	---	---
May	\bar{X}	---	---	---	---
	σ	---	---	---	---
	V, %	---	---	---	---
June	\bar{X}	---	---	---	---
	σ	---	---	---	---
	V, %	---	---	---	---
Year	\bar{X}	0.16			
	σ	0.03			
	V, %	16.66			

Table 6

Average Length of Thawing Period for Roof System 5, Days

Building Identification		5			
Roofing Layer		25 mil Diathon	Polyurethane Foam	Gypsum Concrete	Gypsum Plank
Depth in Section (in.)		0.0	1.0	3.0	4.0
July	\bar{X}	---	---	---	---
	σ	---	---	---	---
	V, %	---	---	---	---
August	\bar{X}	---	---	---	---
	σ	---	---	---	---
	V, %	---	---	---	---
September	\bar{X}	---	---	---	---
	σ	---	---	---	---
	V, %	---	---	---	---
October	\bar{X}	---	---	---	---
	σ	---	---	---	---
	V, %	---	---	---	---
November	\bar{X}	12.30	---	---	---
	σ	11.82	---	---	---
	V, %	96.11	---	---	---
December	\bar{X}	2.75	---	---	---
	σ	1.08	---	---	---
	V, %	39.18	---	---	---
January	\bar{X}	1.36	---	---	---
	σ	0.26	---	---	---
	V, %	18.89	---	---	---
February	\bar{X}	1.77	---	---	---
	σ	0.55	---	---	---
	V, %	31.00	---	---	---
March	\bar{X}	3.57	---	---	---
	σ	1.80	---	---	---
	V, %	50.41	---	---	---
April	\bar{X}	26.24	---	---	---
	σ	7.52	---	---	---
	V, %	28.65	---	---	---
May	\bar{X}	---	---	---	---
	σ	---	---	---	---
	V, %	---	---	---	---
June	\bar{X}	---	---	---	---
	σ	---	---	---	---
	V, %	---	---	---	---
Year	\bar{X}	6.18	---	---	---
	σ	0.48	---	---	---
	V, %	7.74	---	---	---

Table 7

Average Number of Freeze-Thaw Cycles for Roof System 5

Building Identification		5			
Roofing Layer		25 mil Diathon	Polyurethane Foam	Gypsum Concrete	Gypsum Plank
Depth in Section (in.)		0.0	1.0	3.0	4.0
July	\bar{X}	---	---	---	---
	σ	---	---	---	---
	V, %	---	---	---	---
August	\bar{X}	---	---	---	---
	σ	---	---	---	---
	V, %	---	---	---	---
September	\bar{X}	---	---	---	---
	σ	---	---	---	---
	V, %	---	---	---	---
October	\bar{X}	---	---	---	---
	σ	---	---	---	---
	V, %	---	---	---	---
November	\bar{X}	2.75	0.00	0.00	0.00
	σ	1.89			
	V, %	68.84			
December	\bar{X}	10.75	0.00	0.00	0.00
	σ	3.30			
	V, %	30.74			
January	\bar{X}	19.25	0.00	0.00	0.00
	σ	2.87			
	V, %	14.92			
February	\bar{X}	14.75	0.00	0.00	0.00
	σ	5.56			
	V, %	37.70			
March	\bar{X}	9.00	0.00	0.00	0.00
	σ	4.55			
	V, %	50.51			
April	\bar{X}	0.25	0.00	0.00	0.00
	σ	0.50			
	V, %	200.00			
May	\bar{X}	---	---	---	---
	σ	---	---	---	---
	V, %	---	---	---	---
June	\bar{X}	---	---	---	---
	σ	---	---	---	---
	V, %	---	---	---	---
Year	\bar{X}	56.75	0.00	0.00	0.00
	σ	4.57			
	V, %	8.06			

Table 8

Average Temperature Above Freezing for Roof System 18, °F

Building Identification		18			
Roofing Layer		Gacoflex	Built-Up Roofing	Insulation	Gypsum Plank
Depth in Section (in.)		0.0	0.5	1.0	2.5
July	\bar{X}	87.59	86.90	86.01	85.01
	σ	1.30	1.15	0.74	0.20
	V, %	1.48	1.32	0.86	0.23
August	\bar{X}	86.20	85.68	85.30	84.93
	σ	1.76	1.60	1.04	0.25
	V, %	2.04	1.87	1.22	0.29
September	\bar{X}	79.34	79.67	81.49	84.13
	σ	2.33	2.17	1.42	0.34
	V, %	2.94	2.73	1.74	0.41
October	\bar{X}	71.49	72.51	76.84	83.06
	σ	1.97	1.83	1.19	0.31
	V, %	2.76	2.52	1.55	0.37
November	\bar{X}	59.67	60.86	69.07	81.24
	σ	1.94	1.82	1.40	0.34
	V, %	3.26	2.99	2.02	0.42
December	\bar{X}	55.57	56.62	66.02	80.53
	σ	3.07	3.50	2.38	0.56
	V, %	5.52	6.18	3.60	0.69
January	\bar{X}	52.55	52.76	62.46	79.71
	σ	2.79	3.48	2.78	0.65
	V, %	5.30	6.59	4.44	0.82
February	\bar{X}	54.12	54.77	63.24	79.88
	σ	2.32	2.36	1.67	0.39
	V, %	4.29	4.31	2.63	0.49
March	\bar{X}	58.95	59.89	67.84	80.95
	σ	2.01	1.75	1.79	0.43
	V, %	3.41	2.93	2.65	0.53
April	\bar{X}	66.07	67.02	72.98	82.09
	σ	1.75	1.63	1.31	0.33
	V, %	2.65	2.43	1.80	0.40
May	\bar{X}	74.62	74.79	78.13	83.19
	σ	1.51	1.38	0.88	0.21
	V, %	2.03	1.84	1.13	0.25
June	\bar{X}	83.17	82.72	83.25	84.33
	σ	1.73	1.60	1.04	0.24
	V, %	2.08	1.94	1.25	0.29
Year	\bar{X}	69.71	69.96	74.45	82.44
	σ	0.54	0.63	0.63	0.18
	V, %	0.77	0.90	0.84	0.21

$$^{\circ}\text{C} = (^{\circ}\text{F} - 32)/1.8$$

Table 9

Average Temperature Below Freezing for Roof System 18, °F

Building Identification		18			
Roofing Layer		Gacoflex	Built-Up Roofing	Insulation	Gypsum Plank
Depth in Section (in.)		0.0	0.5	1.0	2.5
July	\bar{X}	---	---	---	---
	σ				
	V, %				
August	\bar{X}	---	---	---	---
	σ				
	V, %				
September	\bar{X}	---	---	---	---
	σ				
	V, %				
October	\bar{X}	---	---	---	---
	σ				
	V, %				
November	\bar{X}	28.74	28.38	---	---
	σ	2.61	0.00		
	V, %	9.07	0.00		
December	\bar{X}	28.56	30.30	---	---
	σ	1.55	1.41		
	V, %	5.43	4.65		
January	\bar{X}	26.58	28.70	---	---
	σ	3.36	2.64		
	V, %	12.64	9.21		
February	\bar{X}	27.11	28.81	---	---
	σ	1.49	1.00		
	V, %	5.49	3.45		
March	\bar{X}	27.81	29.22	---	---
	σ	0.78	1.79		
	V, %	2.80	6.13		
April	\bar{X}	28.63	31.31	---	---
	σ	0.44	0.43		
	V, %	1.55	1.36		
May	\bar{X}	---	---	---	---
	σ				
	V, %				
June	\bar{X}	---	---	---	---
	σ				
	V, %				
Year	\bar{X}	27.38	28.87		
	σ	1.26	1.27		
	V, %	4.60	4.39		

$$^{\circ}\text{C} = (^{\circ}\text{F} - 32)/1.8$$

Table 10

Average Cooling Rate for Roof System 18, °F/hr

Building Identification		18			
Roofing Layer	Gacoflex	Built-Up Roofing	Insulation	Gypsum Plank	
Depth in Section (in.)	0.0	0.5	1.0	2.5	
July	\bar{X}	1.62	1.62	1.08	0.27
	σ	0.14	0.15	0.10	0.03
	V, %	8.95	9.02	9.09	9.43
August	\bar{X}	1.74	1.73	1.14	0.27
	σ	0.14	0.14	0.10	0.02
	V, %	8.18	8.32	8.44	8.97
September	\bar{X}	1.84	1.77	1.15	0.26
	σ	0.12	0.12	0.08	0.02
	V, %	6.65	6.68	6.71	6.92
October	\bar{X}	1.60	1.53	1.00	0.23
	σ	0.18	0.17	0.11	0.03
	V, %	11.03	11.03	11.06	11.23
November	\bar{X}	1.62	1.55	1.01	0.23
	σ	0.13	0.12	0.08	0.02
	V, %	7.84	7.88	7.87	7.83
December	\bar{X}	1.44	1.38	0.90	0.20
	σ	0.16	0.15	0.10	0.02
	V, %	11.23	11.20	11.20	11.18
January	\bar{X}	1.45	1.40	0.91	0.20
	σ	0.11	0.11	0.07	0.02
	V, %	7.63	7.65	7.71	8.05
February	\bar{X}	1.71	1.64	1.07	0.24
	σ	0.20	0.19	0.12	0.03
	V, %	11.49	11.50	11.49	11.42
March	\bar{X}	1.95	1.87	1.21	0.27
	σ	0.19	0.18	0.12	0.03
	V, %	9.51	9.51	9.52	9.63
April	\bar{X}	2.01	1.97	1.29	0.30
	σ	0.15	0.14	0.09	0.02
	V, %	7.33	7.24	7.19	6.95
May	\bar{X}	1.84	1.83	1.21	0.29
	σ	0.16	0.16	0.11	0.03
	V, %	8.49	8.59	8.66	9.00
June	\bar{X}	1.71	1.71	1.14	0.28
	σ	0.10	0.10	0.07	0.02
	V, %	5.88	5.89	5.89	5.87
Year	\bar{X}	1.71	1.67	1.09	0.25
	σ	0.08	0.08	0.05	0.01
	V, %	4.84	4.82	4.83	4.92

$$^{\circ}\text{C/hr} = (^{\circ}\text{F/hr})/1.8$$

Table 11

Average Warming Rate for Roof System 18, °F/hr

Building Identification		18			
Roofing Layer		Gacoflex	Built-Up Roofing	Insulation	Gypsum Plank
Depth in Section (in.)		0.0	0.5	1.0	2.5
July	\bar{X}	3.24	3.24	2.16	0.53
	σ	0.27	0.27	0.18	0.05
	V, %	8.35	8.44	8.51	8.86
August	\bar{X}	3.47	3.44	2.27	0.54
	σ	0.27	0.28	0.18	0.05
	V, %	7.86	8.02	8.14	8.69
September	\bar{X}	3.63	3.50	2.28	0.52
	σ	0.25	0.24	0.16	0.04
	V, %	6.77	6.78	6.82	7.00
October	\bar{X}	3.17	3.04	1.98	0.45
	σ	0.32	0.31	0.20	0.05
	V, %	10.23	10.24	10.27	10.43
November	\bar{X}	3.18	3.05	1.99	0.44
	σ	0.27	0.26	0.17	0.04
	V, %	8.52	8.54	8.53	8.48
December	\bar{X}	2.88	2.77	1.80	0.40
	σ	0.30	0.28	0.19	0.04
	V, %	10.29	10.29	10.29	10.42
January	\bar{X}	2.89	2.78	1.81	0.40
	σ	0.24	0.23	0.15	0.04
	V, %	8.35	8.33	8.38	8.70
February	\bar{X}	3.45	3.30	2.15	0.48
	σ	0.42	0.40	0.26	0.06
	V, %	12.20	12.20	12.18	12.12
March	\bar{X}	3.91	3.74	2.44	0.55
	σ	0.38	0.36	0.24	0.05
	V, %	9.71	9.72	9.74	9.90
April	\bar{X}	4.07	3.99	2.62	0.60
	σ	0.25	0.24	0.16	0.03
	V, %	6.05	6.02	5.97	5.76
May	\bar{X}	3.71	3.69	2.45	0.59
	σ	0.35	0.35	0.23	0.06
	V, %	9.35	9.40	9.45	9.71
June	\bar{X}	3.46	3.45	2.31	0.57
	σ	0.22	0.22	0.14	0.04
	V, %	6.34	6.31	6.28	6.20
Year	\bar{X}	3.42	3.33	2.19	0.51
	σ	0.17	0.16	0.11	0.02
	V, %	4.86	4.83	4.83	4.84

$$^{\circ}\text{C/hr} = (^{\circ}\text{F/hr})/1.8$$

Table 12

Average Length of Freezing Period for Roof System 18, Days

Building Identification		18			
Roofing Layer		Gacoflex	Built-Up Roofing	Insulation	Gypsum Plank
Depth in Section (in.)		0.0	0.5	1.0	2.5
July	\bar{X}	---	---	---	---
	σ	---	---	---	---
	V, %	---	---	---	---
August	\bar{X}	---	---	---	---
	σ	---	---	---	---
	V, %	---	---	---	---
September	\bar{X}	---	---	---	---
	σ	---	---	---	---
	V, %	---	---	---	---
October	\bar{X}	---	---	---	---
	σ	---	---	---	---
	V, %	---	---	---	---
November	\bar{X}	0.07	---	---	---
	σ	0.08	---	---	---
	V, %	109.79	---	---	---
December	\bar{X}	0.12	---	---	---
	σ	0.06	---	---	---
	V, %	46.97	---	---	---
January	\bar{X}	0.21	---	---	---
	σ	0.13	---	---	---
	V, %	60.31	---	---	---
February	\bar{X}	0.16	---	---	---
	σ	0.05	---	---	---
	V, %	29.16	---	---	---
March	\bar{X}	0.09	---	---	---
	σ	0.05	---	---	---
	V, %	56.07	---	---	---
April	\bar{X}	0.03	---	---	---
	σ	0.04	---	---	---
	V, %	149.69	---	---	---
May	\bar{X}	---	---	---	---
	σ	---	---	---	---
	V, %	---	---	---	---
June	\bar{X}	---	---	---	---
	σ	---	---	---	---
	V, %	---	---	---	---
Year	\bar{X}	0.16	---	---	---
	σ	0.04	---	---	---
	V, %	26.34	---	---	---

Table 13

Average Length of Thawing Period for Roof System 18, °F

Building Identification		18			
Roofing Layer		Gacoflex	Built-Up Roofing	Insulation	Gypsum Plank
Depth in Section (in.)		0.0	0.5	1.0	2.5
July	\bar{X}	---	---	---	---
	σ				
	V, %				
August	\bar{X}	---	---	---	---
	σ				
	V, %				
September	\bar{X}	---	---	---	---
	σ				
	V, %				
October	\bar{X}	---	---	---	---
	σ				
	V, %				
November	\bar{X}	15.53	---	---	---
	σ	11.31			
	V, %	72.33			
December	\bar{X}	7.65	---	---	---
	σ	4.68			
	V, %	61.18			
January	\bar{X}	2.94	---	---	---
	σ	2.28			
	V, %	77.49			
February	\bar{X}	2.83	---	---	---
	σ	1.26			
	V, %	44.36			
March	\bar{X}	9.61	---	---	---
	σ	10.60			
	V, %	110.30			
April	\bar{X}	24.15	---	---	---
	σ	9.20			
	V, %	38.09			
May	\bar{X}	---	---	---	---
	σ				
	V, %				
June	\bar{X}	---	---	---	---
	σ				
	V, %				
Year	\bar{X}	11.78			
	σ	5.13			
	V, %	43.53			

Table 14

Average Number of Freeze-Thaw Cycles for Roof System 18

Building Identification		18			
Roofing Layer		Gacoflex	Built-Up Roofing	Insulation	Gypsum Plank
Depth in Section (in.)		0.0	0.5	1.0	2.5
July	\bar{X}	---	---	---	---
	σ				
	V, %				
August	\bar{X}	---	---	---	---
	σ				
	V, %				
September	\bar{X}	---	---	---	---
	σ				
	V, %				
October	\bar{X}	---	---	---	---
	σ				
	V, %				
November	\bar{X}	1.83	0.50	0.00	0.00
	σ	1.60	1.22		
	V, %	87.39	244.95		
December	\bar{X}	4.50	1.67	0.00	0.00
	σ	3.39	1.37		
	V, %	75.36	81.98		
January	\bar{X}	11.83	5.83	0.00	0.00
	σ	5.04	4.45		
	V, %	42.56	76.22		
February	\bar{X}	10.17	6.67	0.00	0.00
	σ	5.46	4.27		
	V, %	53.66	64.11		
March	\bar{X}	4.50	2.50	0.00	0.00
	σ	3.27	2.81		
	V, %	72.69	112.43		
April	\bar{X}	0.50	0.50	0.00	0.00
	σ	0.84	0.84		
	V, %	167.33	167.33		
May	\bar{X}	---	---	---	---
	σ				
	V, %				
June	\bar{X}	---	---	---	---
	σ				
	V, %				
Year	\bar{X}	33.33	17.67	0.00	0.00
	σ	11.08	6.25		
	V, %	33.23	35.38		

Table 15

Average Temperature Above Freezing for Roof System 2, °F

Building Identification:		2				
Roofing Layer		No. 5 Gravel	Styrofoam Insulation	Built-Up Roofing	Gypsum Concrete	Gypsum Plank
Depth in Section (in.)		0.0	2.0	3.0	4.5	6.5
July	\bar{X}	92.56	83.96	76.11	74.54	72.87
	σ	1.78	1.03	0.36	0.24	0.09
	V, %	1.93	1.22	0.48	0.32	0.12
August	\bar{X}	90.85	83.08	75.82	74.40	72.82
	σ	2.21	1.34	0.54	0.35	0.17
	V, %	2.43	1.62	0.71	0.48	0.23
September	\bar{X}	83.39	78.64	74.00	73.09	72.32
	σ	2.49	1.58	0.69	0.48	0.19
	V, %	2.99	2.01	0.93	0.65	0.26
October	\bar{X}	74.54	73.10	71.58	71.42	71.70
	σ	1.84	1.20	0.59	0.43	0.18
	V, %	2.47	1.65	0.82	0.60	0.25
November	\bar{X}	61.77	64.21	67.57	68.63	70.65
	σ	1.86	1.46	0.69	0.49	0.20
	V, %	3.01	2.28	1.02	0.72	0.29
December	\bar{X}	58.11	60.65	66.01	67.55	70.25
	σ	2.68	2.44	1.16	0.83	0.32
	V, %	4.60	4.02	1.76	1.23	0.46
January	\bar{X}	56.22	56.99	64.34	66.38	69.81
	σ	1.76	2.76	1.35	0.97	0.39
	V, %	3.13	4.84	2.09	1.46	0.55
February	\bar{X}	58.82	58.34	64.79	66.65	69.90
	σ	3.27	1.71	0.77	0.55	0.23
	V, %	5.57	2.93	1.19	0.82	0.33
March	\bar{X}	63.95	63.79	67.19	68.30	70.51
	σ	2.54	1.81	0.84	0.60	0.24
	V, %	3.97	2.83	1.24	0.88	0.33
April	\bar{X}	70.51	69.63	69.75	70.08	71.18
	σ	1.55	1.42	0.66	0.47	0.19
	V, %	2.20	2.04	0.95	0.67	0.27
May	\bar{X}	79.10	75.30	72.17	71.78	71.83
	σ	2.03	1.20	0.46	0.30	0.14
	V, %	2.57	1.60	0.64	0.42	0.19
June	\bar{X}	88.02	80.93	74.62	73.48	72.47
	σ	1.91	1.19	0.52	0.36	0.17
	V, %	2.17	1.47	0.69	0.50	0.24
Year	\bar{X}	74.09	70.79	70.37	70.55	71.37
	σ	0.68	0.56	0.31	0.23	0.14
	V, %	0.92	0.79	0.44	0.32	0.20

$$^{\circ}\text{C} = (^{\circ}\text{F} - 32)/1.8$$

Table 16

Average Temperature Below Freezing for Roof System 2, °F

Building Identification		2				
Roofing Layer		No. 5 Gravel	Styrofoam Insulation	Built-Up Roofing	Gypsum Concrete	Gypsum Plank
Depth in Section (in.)		0.0	2.0	3.0	4.5	6.5
July	\bar{X}	---	---	---	---	---
	σ	---	---	---	---	---
	V, %	---	---	---	---	---
August	\bar{X}	---	---	---	---	---
	σ	---	---	---	---	---
	V, %	---	---	---	---	---
September	\bar{X}	---	---	---	---	---
	σ	---	---	---	---	---
	V, %	---	---	---	---	---
October	\bar{X}	---	---	---	---	---
	σ	---	---	---	---	---
	V, %	---	---	---	---	---
November	\bar{X}	26.28	---	---	---	---
	σ	3.28	---	---	---	---
	V, %	12.47	---	---	---	---
December	\bar{X}	27.94	---	---	---	---
	σ	1.98	---	---	---	---
	V, %	7.09	---	---	---	---
January	\bar{X}	24.80	---	---	---	---
	σ	3.91	---	---	---	---
	V, %	15.77	---	---	---	---
February	\bar{X}	25.45	---	---	---	---
	σ	2.24	---	---	---	---
	V, %	8.81	---	---	---	---
March	\bar{X}	27.30	---	---	---	---
	σ	2.19	---	---	---	---
	V, %	8.02	---	---	---	---
April	\bar{X}	28.82	---	---	---	---
	σ	2.08	---	---	---	---
	V, %	7.21	---	---	---	---
May	\bar{X}	---	---	---	---	---
	σ	---	---	---	---	---
	V, %	---	---	---	---	---
June	\bar{X}	---	---	---	---	---
	σ	---	---	---	---	---
	V, %	---	---	---	---	---
Year	\bar{X}	26.00	---	---	---	---
	σ	1.29	---	---	---	---
	V, %	4.95	---	---	---	---

$$^{\circ}\text{C} = (^{\circ}\text{F} - 32)/1.8$$

Table 17

Average Cooling Rate for Roof System 2, °F/hr

Building Identification		2				
Roofing Layer		No. 5 Gravel	Styrofoam Insulation	Built-Up Roofing	Gypsum Concrete	Gypsum Plank
Depth in Section (in.)		0.0	2.0	3.0	4.5	6.5
July	\bar{X}	2.47	1.51	0.46	0.24	0.07
	σ	0.23	0.14	0.05	0.03	0.01
	V, %	9.19	9.39	10.18	10.80	11.55
August	\bar{X}	2.63	1.59	0.47	0.24	0.07
	σ	0.24	0.15	0.05	0.03	0.01
	V, %	9.19	9.49	10.56	11.39	12.35
September	\bar{X}	2.65	1.56	0.44	0.22	0.06
	σ	0.19	0.11	0.03	0.02	0.01
	V, %	7.04	7.18	7.87	8.48	9.26
October	\bar{X}	2.28	1.33	0.36	0.18	0.05
	σ	0.26	0.15	0.04	0.02	0.01
	V, %	11.24	11.37	11.96	12.30	12.98
November	\bar{X}	2.19	1.27	0.33	0.16	0.04
	σ	0.17	0.10	0.03	0.01	0.00
	V, %	7.57	7.63	7.71	6.41	9.27
December	\bar{X}	1.90	1.09	0.28	0.13	0.03
	σ	0.21	0.12	0.03	0.01	0.00
	V, %	10.85	10.81	10.82	11.09	11.53
January	\bar{X}	1.93	1.11	0.28	0.13	0.03
	σ	0.16	0.09	0.02	0.01	0.00
	V, %	8.36	8.25	7.99	7.12	6.14
February	\bar{X}	2.34	1.35	0.35	0.17	0.04
	σ	0.26	0.15	0.04	0.01	0.00
	V, %	11.18	11.03	10.05	8.96	8.55
March	\bar{X}	2.73	1.58	0.43	0.21	0.06
	σ	0.26	0.15	0.04	0.02	0.00
	V, %	9.34	9.29	9.29	9.33	8.59
April	\bar{X}	2.91	1.73	0.49	0.25	0.07
	σ	0.19	0.11	0.03	0.01	0.00
	V, %	6.47	6.34	6.09	6.00	4.84
May	\bar{X}	2.76	1.67	0.50	0.26	0.07
	σ	0.24	0.15	0.05	0.03	0.01
	V, %	8.78	8.98	9.66	10.21	10.89
June	\bar{X}	2.61	1.60	0.49	0.26	0.07
	σ	0.15	0.09	0.03	0.02	0.00
	V, %	5.56	5.60	5.77	5.99	6.35
Year	\bar{X}	2.45	1.45	0.41	0.20	0.06
	σ	0.12	0.07	0.02	0.01	0.00
	V, %	4.87	4.87	5.09	5.01	4.68

°C/hr = (°F/hr)/1.8

Table 18

Average Warming Rate for Roof System 2, °F/hr

Building Identification		2				
Roofing Layer		No. 5 Gravel	Styrofoam Insulation	Built-Up Roofing	Gypsum Concrete	Gypsum Plank
Depth in Section (in.)		0.0	2.0	3.0	4.5	6.5
July	\bar{X}	4.95	3.03	0.93	0.50	0.14
	σ	0.43	0.27	0.09	0.05	0.01
	V, %	8.67	8.86	9.51	10.01	10.57
August	\bar{X}	5.24	3.16	0.93	0.48	0.13
	σ	0.47	0.29	0.10	0.05	0.02
	V, %	8.96	9.26	10.31	10.11	12.03
September	\bar{X}	5.25	3.08	0.86	0.43	0.12
	σ	0.38	0.23	0.07	0.04	0.01
	V, %	7.20	7.32	7.93	8.50	9.27
October	\bar{X}	4.52	2.63	0.72	0.35	0.09
	σ	0.47	0.28	0.08	0.04	0.01
	V, %	10.48	10.59	11.04	11.82	12.16
November	\bar{X}	4.31	2.49	0.64	0.30	0.07
	σ	0.35	0.20	0.05	0.03	0.01
	V, %	8.04	8.11	8.37	10.57	11.13
December	\bar{X}	3.80	2.19	0.55	0.24	0.05
	σ	0.38	0.22	0.05	0.03	0.01
	V, %	10.08	9.96	9.75	10.55	14.33
January	\bar{X}	3.86	2.21	0.55	0.24	0.05
	σ	0.34	0.19	0.05	0.02	0.01
	V, %	8.75	8.66	8.65	9.35	11.17
February	\bar{X}	4.72	2.72	0.71	0.33	0.08
	σ	0.55	0.32	0.08	0.04	0.01
	V, %	11.72	1.62	11.01	11.41	9.23
March	\bar{X}	5.47	3.17	0.86	0.42	0.11
	σ	0.53	0.31	0.09	0.04	0.01
	V, %	9.72	9.70	9.91	10.18	11.01
April	\bar{X}	5.89	3.50	0.99	0.50	0.14
	σ	0.30	0.17	0.05	0.02	0.01
	V, %	5.08	4.97	4.66	4.54	5.37
May	\bar{X}	5.55	3.37	1.00	0.52	0.15
	σ	0.53	0.33	0.10	0.06	0.02
	V, %	9.62	9.78	10.40	10.91	11.54
June	\bar{X}	5.27	3.23	1.00	0.53	0.15
	σ	0.31	0.19	0.06	0.03	0.01
	V, %	5.83	5.84	5.95	6.10	6.33
Year	\bar{X}	4.90	2.90	0.81	0.40	0.11
	σ	0.24	0.14	0.04	0.02	0.01
	V, %	4.88	4.87	4.97	5.41	6.16

$$^{\circ}\text{C/hr} = (^{\circ}\text{F/hr})/1.8$$

Table 19

Average Length of Freezing Period for Roof System 2, Days

Building Identification		2				
Roofing Layer		No. 5 Gravel	Styrofoam Insulation	Built-Up Roofing	Gypsum Concrete	Gypsum Plank
Depth in Section (in.)		0.0	2.0	3.0	4.5	6.5
July	\bar{X} σ V, %	---	---	---	---	---
August	\bar{X} σ V, %	---	---	---	---	---
September	\bar{X} σ V, %	---	---	---	---	---
October	\bar{X} σ V, %	---	---	---	---	---
November	\bar{X} σ V, %	0.09 0.08 91.20	---	---	---	---
December	\bar{X} σ V, %	0.11 0.07 60.98	---	---	---	---
January	\bar{X} σ V, %	0.21 0.11 54.54	---	---	---	---
February	\bar{X} σ V, %	0.15 0.05 33.20	---	---	---	---
March	\bar{X} σ V, %	0.09 0.04 47.36	---	---	---	---
April	\bar{X} σ V, %	0.03 0.04 135.67	---	---	---	---
May	\bar{X} σ V, %	---	---	---	---	---
June	\bar{X} σ V, %	---	---	---	---	---
Year	\bar{X} σ V, %	0.15 0.03 20.40	--	---	---	---

Table 20

Average Length of Thawing Period for Roof System 2, Days

Building Identification		2				
Roofing Layer		No. 5 Gravel	Styrofoam Insulation	Built-Up Roofing	Gypsum Concrete	Gypsum Plank
Depth in Section (in.)		0.0	2.0	3.0	4.5	6.5
July	\bar{X}	---	---	---	---	---
	σ	---	---	---	---	---
	V, %	---	---	---	---	---
August	\bar{X}	---	---	---	---	---
	σ	---	---	---	---	---
	V, %	---	---	---	---	---
September	\bar{X}	---	---	---	---	---
	σ	---	---	---	---	---
	V, %	---	---	---	---	---
October	\bar{X}	---	---	---	---	---
	σ	---	---	---	---	---
	V, %	---	---	---	---	---
November	\bar{X}	15.52	---	---	---	---
	σ	11.32	---	---	---	---
	V, %	90.44	---	---	---	---
December	\bar{X}	6.36	---	---	---	---
	σ	4.94	---	---	---	---
	V, %	77.69	---	---	---	---
January	\bar{X}	2.66	---	---	---	---
	σ	2.38	---	---	---	---
	V, %	89.54	---	---	---	---
February	\bar{X}	2.34	---	---	---	---
	σ	0.84	---	---	---	---
	V, %	36.13	---	---	---	---
March	\bar{X}	6.16	---	---	---	---
	σ	4.83	---	---	---	---
	V, %	78.48	---	---	---	---
April	\bar{X}	20.40	---	---	---	---
	σ	10.80	---	---	---	---
	V, %	52.94	---	---	---	---
May	\bar{X}	---	---	---	---	---
	σ	---	---	---	---	---
	V, %	---	---	---	---	---
June	\bar{X}	---	---	---	---	---
	σ	---	---	---	---	---
	V, %	---	---	---	---	---
Year	\bar{X}	9.86	---	---	---	---
	σ	4.87	---	---	---	---
	V, %	49.44	---	---	---	---

$^{\circ}\text{C} = (^{\circ}\text{F} - 32)/1.8$

Table 21

Average Number of Freeze-Thaw Cycles for Roof System 2

Building Identification		2				
Roofing Layer		No. 5 Gravel	Styrofoam Insulation	Built-Up Roofing	Gypsum Concrete	Gypsum Plank
Depth in Section (in.)		0.0	2.0	3.0	4.5	6.5
July	\bar{X} σ V, %	---	---	---	---	---
August	\bar{X} σ V, %	---	---	---	---	---
September	\bar{X} σ V, %	---	---	---	---	---
October	\bar{X} σ V, %	---	---	---	---	---
November	\bar{X} σ V, %	1.83 1.60 87.39	0.00	0.00	0.00	0.00
December	\bar{X} σ V, %	6.33 4.72 74.51	0.00	0.00	0.00	0.00
January	\bar{X} σ V, %	14.00 6.20 44.26	0.00	0.00	0.00	0.00
February	\bar{X} σ V, %	11.67 5.39 46.21	0.00	0.00	0.00	0.00
March	\bar{X} σ V, %	6.17 4.17 67.58	0.00	0.00	0.00	0.00
April	\bar{X} σ V, %	1.00 1.26 126.49	0.00	0.00	0.00	0.00
May	\bar{X} σ V, %	---	---	---	---	---
June	\bar{X} σ V, %	---	---	---	---	---
Year	\bar{X} σ V, %	41.00 14.37 35.04	0.00	0.00	0.00	0.00

Table 22

Average Temperature Above Freezing for Roof System 3A, °F

Building Identification		3				
Roofing Layer		Light Colored Gravel		Built-up Roofing	Urethane Board	Gypsum Plank
Depth in Section (in.)		0.0	0.5	1.0	1.5	3.0
July	\bar{X}	92.65	92.39	90.64	83.22	73.90
	σ	2.00	1.98	1.80	1.08	0.21
	V, %	2.16	2.14	1.98	1.30	0.28
August	\bar{X}	90.71	90.50	89.07	82.36	73.82
	σ	2.44	2.41	2.24	1.37	0.27
	V, %	2.69	2.67	2.52	1.67	0.37
September	\bar{X}	83.31	80.25	82.66	78.51	73.14
	σ	2.76	2.75	2.60	1.60	0.31
	V, %	3.31	3.30	3.15	2.04	0.41
October	\bar{X}	74.96	74.99	74.95	73.77	72.25
	σ	1.63	1.62	1.52	0.95	0.20
	V, %	2.17	2.16	2.03	1.28	0.27
November	\bar{X}	61.74	61.63	62.31	65.33	70.64
	σ	1.56	1.85	1.74	1.38	0.28
	V, %	2.53	3.00	2.80	2.11	0.40
December	\bar{X}	58.14	57.93	57.68	61.91	69.99
	σ	2.77	2.75	2.92	2.22	0.43
	V, %	4.77	4.75	5.06	3.59	0.61
January	\bar{X}	56.55	56.24	56.19	58.76	69.40
	σ	1.71	1.86	2.18	2.67	0.51
	V, %	3.02	3.31	3.88	4.54	0.74
February	\bar{X}	59.38	59.19	58.61	60.37	69.70
	σ	3.98	3.61	3.28	1.72	0.33
	V, %	6.70	6.10	5.59	2.84	0.47
March	\bar{X}	64.33	64.16	63.57	64.87	70.55
	σ	2.80	2.80	1.96	1.56	0.31
	V, %	4.35	4.37	3.09	2.40	0.44
April	\bar{X}	70.33	70.24	69.96	70.18	71.52
	σ	1.44	1.43	1.48	1.21	0.25
	V, %	2.05	2.04	2.11	1.73	0.35
May	\bar{X}	79.01	78.80	77.81	75.32	72.42
	σ	2.12	2.09	1.91	1.16	0.22
	V, %	2.68	2.65	2.46	1.54	0.30
June	\bar{X}	87.87	87.60	86.02	80.33	73.31
	σ	1.92	1.91	1.77	1.09	0.22
	V, %	2.19	2.18	2.06	1.35	0.30
Year	\bar{X}	74.24	74.03	73.19	71.31	71.73
	σ	0.77	0.68	0.47	0.43	0.12
	V, %	1.04	0.92	0.64	0.60	0.16

$$^{\circ}\text{C} = (^{\circ}\text{F} - 32)/1.8$$

Table 23

Average Temperature Below Freezing for Roof System 3A, °F

Building Identification		3				
Roofing Layer		Light Colored Gravel		Built-Up Roofing	Urethane Board	Gypsum Plank
Depth in Section (in.)		0.0	0.5	1.0	1.5	3.0
July	\bar{X}	---	---	---	---	---
	σ	---	---	---	---	---
	V, %	---	---	---	---	---
August	\bar{X}	---	---	---	---	---
	σ	---	---	---	---	---
	V, %	---	---	---	---	---
September	\bar{X}	---	---	---	---	---
	σ	---	---	---	---	---
	V, %	---	---	---	---	---
October	\bar{X}	---	---	---	---	---
	σ	---	---	---	---	---
	V, %	---	---	---	---	---
November	\bar{X}	26.31	25.65	27.87		
	σ	3.95	3.14	3.09	---	---
	V, %	15.01	12.24	11.08		
December	\bar{X}	27.79	27.77	28.51		
	σ	1.49	1.58	1.43	---	---
	V, %	5.35	5.68	5.03		
January	\bar{X}	24.27	24.17	25.77		
	σ	3.29	3.32	3.32	---	---
	V, %	13.55	13.73	12.90		
February	\bar{X}	25.99	25.99	26.66		
	σ	1.94	2.05	1.72	---	---
	V, %	7.46	7.88	6.46		
March	\bar{X}	26.59	26.54	27.29		
	σ	1.14	1.05	0.74	---	---
	V, %	4.30	3.94	2.72		
April	\bar{X}	28.41	28.20	29.15		
	σ	1.80	1.75	2.28	---	---
	V, %	6.33	6.19	7.81		
May	\bar{X}	---	---	---	---	---
	σ	---	---	---	---	---
	V, %	---	---	---	---	---
June	\bar{X}	---	---	---	---	---
	σ	---	---	---	---	---
	V, %	---	---	---	---	---
Year	\bar{X}	26.07	25.92	26.82		
	σ	1.18	1.27	1.42		
	V, %	4.54	4.89	5.29		

$$^{\circ}\text{C} = (^{\circ}\text{F} - 32)/1.8$$

Table 24

Average Cooling Rate for Roof System 3A, °F/hr

Building Identification		3				
Roofing Layer		Light Colored Gravel		Built-Up Roofing	Urethane Board	Gypsum Plank
Depth in Section (in.)		0.0	0.5	1.0	1.5	3.0
July	\bar{X}	2.42	2.45	2.43	1.53	0.29
	σ	0.25	0.25	0.25	0.16	0.03
	V, %	10.20	10.22	10.33	10.42	10.90
August	\bar{X}	2.56	2.58	2.54	1.57	0.29
	σ	0.26	0.26	0.26	0.16	0.03
	V, %	10.01	10.05	10.19	10.31	10.95
September	\bar{X}	2.66	2.66	2.57	1.57	0.28
	σ	0.18	0.18	0.18	0.11	0.02
	V, %	6.89	6.90	6.91	6.96	7.32
October	\bar{X}	2.27	2.27	2.18	1.34	0.24
	σ	0.28	0.28	0.27	0.17	0.03
	V, %	12.33	12.34	12.38	12.43	12.72
November	\bar{X}	2.21	2.21	2.13	1.30	0.22
	σ	0.15	0.15	0.15	0.09	0.02
	V, %	6.76	6.78	6.87	6.92	7.17
December	\bar{X}	1.93	1.93	1.86	1.13	0.19
	σ	0.20	0.20	0.19	0.12	0.02
	V, %	10.25	10.24	10.22	10.21	10.21
January	\bar{X}	1.96	1.96	1.88	1.15	0.20
	σ	0.17	0.17	0.17	0.10	0.02
	V, %	8.94	8.92	8.90	8.93	9.19
February	\bar{X}	2.33	2.33	2.24	1.37	0.24
	σ	0.29	0.29	0.28	0.17	0.03
	V, %	12.42	12.42	12.44	12.43	12.27
March	\bar{X}	2.79	2.79	2.67	1.64	0.29
	σ	0.21	0.21	0.20	0.12	0.02
	V, %	7.56	7.55	7.51	7.53	7.69
April	\bar{X}	2.88	2.90	2.83	1.74	0.31
	σ	0.21	0.21	0.20	0.12	0.02
	V, %	7.26	7.24	7.18	7.15	7.00
May	\bar{X}	2.68	2.71	2.68	1.67	0.31
	σ	0.26	0.26	0.26	0.16	0.03
	V, %	9.65	9.68	9.80	9.89	10.34
June	\bar{X}	2.56	2.58	2.58	1.61	0.31
	σ	0.16	0.16	0.16	0.10	0.02
	V, %	6.11	6.12	6.16	6.19	6.35
Year	\bar{X}	2.44	2.45	2.38	1.47	0.26
	σ	0.12	0.13	0.12	0.08	0.01
	V, %	5.11	5.11	5.12	5.15	5.34

$$^{\circ}\text{C/hr} = (^{\circ}\text{F/hr})/1.8$$

Table 25

Average Warming Rate for Roof System 3A, °F/hr

Building Identification		3				
Roofing Layer		Light Colored Gravel		Built-Up Roofing	Urethane Board	Gypsum Plank
Depth in Section (in.)		0.0	0.5	1.0	1.5	3.0
July	\bar{X}	4.85	4.90	4.88	3.05	0.58
	σ	0.47	0.47	0.48	0.30	0.06
	V, %	9.61	9.64	9.76	9.85	10.33
August	\bar{X}	5.11	5.16	5.07	3.14	0.58
	σ	0.50	0.51	0.51	0.32	0.06
	V, %	9.83	9.88	10.02	10.15	10.80
September	\bar{X}	5.25	5.27	5.07	3.11	0.55
	σ	0.39	0.39	0.37	0.23	0.04
	V, %	7.38	7.38	7.39	7.43	7.76
October	\bar{X}	4.51	4.51	4.34	2.66	0.47
	σ	0.51	0.51	0.50	0.31	0.06
	V, %	11.40	11.40	11.45	11.49	11.77
November	\bar{X}	4.35	4.35	4.19	2.56	0.44
	σ	0.32	0.32	0.31	0.19	0.03
	V, %	7.39	7.41	7.47	7.51	7.70
December	\bar{X}	3.86	3.87	3.72	2.27	0.39
	σ	0.37	0.37	0.35	0.21	0.04
	V, %	9.47	9.46	9.44	9.44	9.44
January	\bar{X}	3.90	3.91	3.76	2.29	0.39
	σ	0.37	0.37	0.35	0.22	0.04
	V, %	9.43	9.40	9.37	9.38	9.58
February	\bar{X}	4.72	4.72	4.53	2.77	0.48
	σ	0.61	0.61	0.59	0.36	0.06
	V, %	12.91	12.91	12.92	12.91	12.76
March	\bar{X}	5.57	5.57	5.34	3.27	0.57
	σ	0.48	0.47	0.45	0.28	0.05
	V, %	8.54	8.52	8.49	8.51	8.76
April	\bar{X}	5.82	5.85	5.70	3.51	0.63
	σ	0.33	0.34	0.33	0.20	0.03
	V, %	5.74	5.74	5.71	5.68	5.50
May	\bar{X}	5.40	5.45	5.39	3.35	0.62
	σ	0.57	0.58	0.58	0.36	0.07
	V, %	10.63	10.65	10.74	10.81	11.20
June	\bar{X}	5.16	5.22	5.20	3.25	0.62
	σ	0.33	0.33	0.33	0.21	0.04
	V, %	6.40	6.41	6.42	6.43	6.50
Year	\bar{X}	4.87	4.90	4.76	2.94	0.53
	σ	0.25	0.25	0.24	0.15	0.03
	V, %	5.12	5.12	5.13	5.15	5.34

°C/hr = (°F/hr)1.8

Table 26

Average Length of Freezing Period for Roof System 3A, Days

Building Identification		3				
Roofing Layer		Light Colored Gravel		Built-Up Roofing	Urethane Board	Gypsum Plank
Depth in Section (in.)		0.0	0.5	1.0	1.5	3.0
July	\bar{X}	---	---	---	---	---
	σ					
	V, %					
August	\bar{X}	---	---	---	---	---
	σ					
	V, %					
September	\bar{X}	---	---	---	---	---
	σ					
	V, %					
October	\bar{X}	---	---	---	---	---
	σ					
	V, %					
November	\bar{X}	0.08	0.09	0.06		
	σ	0.09	0.09	0.07		
	V, %	117.68	103.86	121.73		
December	\bar{X}	0.11	0.11	0.10		
	σ	0.03	0.04	0.04		
	V, %	29.56	34.95	37.70		
January	\bar{X}	0.22	0.23	0.19		
	σ	0.10	0.10	0.10		
	V, %	46.13	45.60	55.63		
February	\bar{X}	0.14	0.14	0.13		
	σ	0.04	0.04	0.04		
	V, %	27.14	30.19	32.61		
March	\bar{X}	0.11	0.11	0.09		
	σ	0.02	0.02	0.02		
	V, %	22.94	21.08	17.19		
April	\bar{X}	0.04	0.04	0.03		
	σ	0.04	0.04	0.04		
	V, %	111.68	109.16	136.82		
May	\bar{X}	---	---	---		
	σ					
	V, %					
June	\bar{X}	---	---	---		
	σ					
	V, %					
Year	\bar{X}	0.15	0.15	0.13		
	σ	0.03	0.03	0.04		
	V, %	18.70	20.25	27.91		

Table 27

Average Length of Thawing Period for Roof System 3A, Days

Building Identification		3				
Roofing Layer		Light Colored Gravel		Built-Up Roofing	Urethane Board	Gypsum Plank
Depth in Section (in.)		0.0	0.5	1.0	1.5	3.0
July	\bar{X}	---	---	---	---	---
	V, %	---	---	---	---	---
August	\bar{X}	---	---	---	---	---
	V, %	---	---	---	---	---
September	\bar{X}	---	---	---	---	---
	V, %	---	---	---	---	---
October	\bar{X}	---	---	---	---	---
	V, %	---	---	---	---	---
November	\bar{X}	21.44	6.64	16.66	---	---
	V, %	21.44	21.44	21.44	---	---
December	\bar{X}	6.17	6.17	7.73	---	---
	V, %	31.79	38.70	60.82	---	---
January	\bar{X}	2.77	2.77	3.06	---	---
	V, %	28.69	35.15	40.29	---	---
February	\bar{X}	1.36	1.40	3.43	---	---
	V, %	38.99	37.05	49.32	---	---
March	\bar{X}	4.18	4.30	5.55	---	---
	V, %	44.02	40.93	32.83	---	---
April	\bar{X}	18.47	18.47	18.98	---	---
	V, %	58.83	58.84	54.12	---	---
May	\bar{X}	---	---	---	---	---
	V, %	---	---	---	---	---
June	\bar{X}	---	---	---	---	---
	V, %	---	---	---	---	---
Year	\bar{X}	9.22	9.60	12.07	---	---
	V, %	59.68	55.37	49.53	---	---

Table 28

Average Number of Freeze-Thaw Cycles for Roof System 3A

Building Identification		3				
Roofing Layer		Light Colored Gravel		Built-Up Roofing	Urethane Board	Gypsum Plank
Depth in Section (in.)		0.0	0.5	1.0	1.5	3.0
July	\bar{X}	---	---	---	---	---
	σ	---	---	---	---	---
	V, %	---	---	---	---	---
August	\bar{X}	---	---	---	---	---
	σ	---	---	---	---	---
	V, %	---	---	---	---	---
September	\bar{X}	---	---	---	---	---
	σ	---	---	---	---	---
	V, %	---	---	---	---	---
October	\bar{X}	---	---	---	---	---
	σ	---	---	---	---	---
	V, %	---	---	---	---	---
November	\bar{X}	2.20	1.80	1.80	---	---
	σ	2.05	1.79	1.79	---	---
	V, %	93.15	99.38	99.38	---	---
December	\bar{X}	7.40	6.80	4.20	---	---
	σ	5.41	4.66	3.03	---	---
	V, %	73.15	68.50	72.22	---	---
January	\bar{X}	14.80	14.00	11.80	---	---
	σ	7.22	6.56	5.02	---	---
	V, %	48.82	46.84	42.54	---	---
February	\bar{X}	12.00	11.60	9.00	---	---
	σ	6.40	6.02	6.04	---	---
	V, %	53.36	51.94	67.13	---	---
March	\bar{X}	7.60	7.20	5.20	---	---
	σ	4.10	3.70	2.77	---	---
	V, %	53.93	51.41	53.36	---	---
April	\bar{X}	1.20	1.20	1.00	---	---
	σ	1.30	1.30	1.00	---	---
	V, %	108.65	108.65	100.00	---	---
May	\bar{X}	---	---	---	---	---
	σ	---	---	---	---	---
	V, %	---	---	---	---	---
June	\bar{X}	---	---	---	---	---
	σ	---	---	---	---	---
	V, %	---	---	---	---	---
Year	\bar{X}	45.20	42.60	33.00	---	---
	σ	15.71	14.52	10.84	---	---
	V, %	34.75	34.08	32.85	---	---

Table 29

Average Temperature Above Freezing for Roof System 3B, °F

Building Identification		3				
Roofing Layer		Light Colored Gravel		Built-Up Roofing	Urethane Board	Gypsum Plank
Depth in Section (in.)		0.0	0.5	1.0	4.5	7.0
July	\bar{X}	93.07	92.86	91.83	77.83	72.40
	σ	1.82	1.80	1.70	0.50	0.07
	V, %	1.96	1.94	1.85	0.65	0.10
August	\bar{X}	91.26	91.10	90.35	77.64	72.38
	σ	2.25	2.24	2.16	0.71	0.13
	V, %	2.47	2.45	2.39	0.92	0.18
September	\bar{X}	83.56	83.54	83.39	75.49	72.20
	σ	2.53	2.53	2.50	0.84	0.12
	V, %	3.03	3.03	2.99	1.12	0.16
October	\bar{X}	74.55	74.59	74.68	72.56	71.96
	σ	1.87	1.87	1.84	0.64	0.09
	V, %	2.51	2.51	2.46	0.88	0.13
November	\bar{X}	61.85	61.90	61.91	67.78	71.55
	σ	1.73	1.73	1.86	0.80	0.11
	V, %	2.80	2.79	3.00	1.18	0.16
December	\bar{X}	58.75	58.89	58.34	65.86	71.39
	σ	1.86	1.68	2.53	1.31	0.16
	V, %	3.17	2.85	4.33	1.99	0.22
January	\bar{X}	56.54	56.43	56.44	63.91	71.23
	σ	1.84	1.71	1.57	1.47	0.16
	V, %	3.26	3.03	2.78	2.29	0.23
February	\bar{X}	59.54	59.40	58.97	64.67	71.28
	σ	3.85	3.82	3.23	0.90	0.13
	V, %	6.47	6.43	5.47	1.39	0.19
March	\bar{X}	64.74	64.71	64.02	67.58	71.52
	σ	2.81	2.83	2.57	0.97	0.13
	V, %	4.35	4.38	4.01	1.43	0.17
April	\bar{X}	70.68	70.58	70.19	70.59	71.78
	σ	1.75	1.75	1.53	0.78	0.12
	V, %	2.48	2.47	2.18	1.10	0.17
May	\bar{X}	79.39	79.20	78.38	73.30	72.01
	σ	2.07	2.05	1.96	0.62	0.07
	V, %	2.61	2.59	2.50	0.84	0.10
June	\bar{X}	88.49	88.26	87.19	76.10	72.25
	σ	1.95	1.94	1.88	0.63	0.09
	V, %	2.20	2.19	2.16	0.82	0.12
Year	\bar{X}	74.58	74.49	73.88	71.15	71.83
	σ	0.81	0.78	0.67	0.31	0.06
	V, %	1.08	1.05	0.91	0.44	0.09

$$^{\circ}\text{C} = (^{\circ}\text{F} - 32)/1.8$$

Table 30

Average Temperature Below Freezing for Roof System 3B, °F

Building Identification		3				
Roofing Layer		Light Colored Gravel		Built-Up Roofing	Urethane Board	Gypsum Plank
Depth in Section (in.)		0.0	0.5	1.0	4.5	7.0
July	\bar{X} σ V, %	---	---	---	---	---
August	\bar{X} σ V, %	---	---	---	---	---
September	\bar{X} σ V, %	---	---	---	---	---
October	\bar{X} σ V, %	---	---	---	---	---
November	\bar{X} σ V, %	26.66 4.02 15.06	26.64 4.08 15.30	25.03 2.77 11.08	---	---
December	\bar{X} σ V, %	27.18 1.41 5.20	27.24 1.51 5.54	26.80 1.43 5.34	---	---
January	\bar{X} σ V, %	23.84 3.60 15.11	23.73 3.51 14.78	24.03 3.48 14.48	---	---
February	\bar{X} σ V, %	24.96 1.55 6.19	24.80 1.66 6.68	24.57 2.23 9.05	---	---
March	\bar{X} σ V, %	26.89 2.28 8.48	26.78 2.10 7.83	26.02 1.84 7.06	---	---
April	\bar{X} σ V, %	27.56 2.42 8.77	27.25 2.48 9.09	26.37 1.57 5.95	---	---
May	\bar{X} σ V, %	---	---	---	---	---
June	\bar{X} σ V, %	---	---	---	---	---
Year	\bar{X} σ V, %	25.56 0.99 3.89	25.45 0.89 3.50	25.05 1.17 4.65	---	---

$$^{\circ}\text{C} = (^{\circ}\text{F} - 32)/1.8$$

Table 31

Average Cooling Rate for Roof System 3B, °F/hr

Building Identification		3				
Roofing Layer		Light Colored Gravel		Built-Up Roofing	Urethane Board	Gypsum Plank
Depth in Section (in.)		0.0	0.5	1.0	4.5	7.0
July	\bar{X}	2.48	2.52	2.61	0.89	0.06
	σ	0.23	0.23	0.24	0.09	0.01
	V, %	9.13	9.16	9.25	9.77	10.40
August	\bar{X}	2.65	2.68	2.75	0.90	0.06
	σ	0.24	0.25	0.26	0.09	0.01
	V, %	9.11	9.15	9.29	10.01	10.92
September	\bar{X}	2.69	2.70	2.71	0.85	0.05
	σ	0.19	0.19	0.19	0.06	0.00
	V, %	7.01	7.02	7.06	7.46	8.10
October	\bar{X}	2.31	2.32	2.32	0.72	0.04
	σ	0.26	0.26	0.26	0.08	0.01
	V, %	11.19	11.19	11.24	11.60	12.08
November	\bar{X}	2.22	2.23	2.24	0.67	0.04
	σ	0.17	0.17	0.17	0.05	0.00
	V, %	7.44	7.46	7.49	7.51	7.74
December	\bar{X}	1.94	1.94	1.95	0.58	0.03
	σ	0.21	0.21	0.21	0.06	0.00
	V, %	10.92	10.91	10.85	10.83	10.96
January	\bar{X}	1.98	1.99	1.99	0.59	0.03
	σ	0.17	0.17	0.17	0.05	0.00
	V, %	8.58	8.59	8.63	8.93	9.02
February	\bar{X}	2.39	2.39	2.39	0.72	0.04
	σ	0.27	0.27	0.27	0.08	0.00
	V, %	11.12	11.13	11.16	11.07	10.53
March	\bar{X}	2.78	2.79	2.79	0.86	0.05
	σ	0.26	0.26	0.26	0.08	0.01
	V, %	9.47	9.47	9.47	9.60	9.71
April	\bar{X}	2.95	2.98	3.02	0.95	0.06
	σ	0.19	0.19	0.19	0.06	0.00
	V, %	6.54	6.53	6.43	6.22	6.06
May	\bar{X}	2.77	2.81	2.90	0.96	0.06
	σ	0.24	0.25	0.26	0.09	0.01
	V, %	8.75	8.78	8.89	9.37	9.89
June	\bar{X}	2.62	2.66	2.76	0.95	0.06
	σ	0.15	0.15	0.15	0.05	0.00
	V, %	5.54	5.55	5.59	5.73	5.92
Year	\bar{X}	2.48	2.50	2.53	0.80	0.05
	σ	0.12	0.12	0.12	0.04	0.00
	V, %	4.92	4.92	4.92	5.08	5.35

$$^{\circ}\text{C/hr} = (^{\circ}\text{F/hr})/1.8$$

Table 32

Average Warming Rate for Roof System 3B, °F/hr

Building Identification		3				
Roofing Layer		Light Colored Gravel		Built-Up Roofing	Urethane Board	Gypsum Plank
Depth in Section (in.)		0.0	0.5	1.0	4.5	7.0
July	\bar{X}	4.98	5.04	5.23	1.78	0.12
	σ	0.43	0.44	0.46	0.17	0.01
	V, %	8.62	8.64	8.75	9.27	9.84
August	\bar{X}	5.28	5.34	5.48	1.78	0.12
	σ	0.47	0.48	0.50	0.17	0.01
	V, %	8.87	8.91	9.06	9.80	10.72
September	\bar{X}	5.33	5.35	5.37	1.68	0.11
	σ	0.38	0.38	0.39	0.13	0.01
	V, %	7.18	7.19	7.22	7.59	8.18
October	\bar{X}	4.58	4.60	4.60	1.42	0.09
	σ	0.48	0.48	0.48	0.15	0.01
	V, %	10.43	10.43	10.48	10.83	11.28
November	\bar{X}	4.38	4.40	4.40	1.32	0.08
	σ	0.35	0.35	0.35	0.11	0.01
	V, %	7.94	7.95	7.97	8.06	8.33
December	\bar{X}	3.88	3.89	3.89	1.15	0.06
	σ	0.39	0.40	0.39	0.12	0.01
	V, %	10.16	10.16	10.11	10.02	9.98
January	\bar{X}	3.96	3.97	3.98	1.18	0.07
	σ	0.36	0.36	0.36	0.11	0.01
	V, %	9.02	9.02	9.04	9.31	9.55
February	\bar{X}	4.82	4.84	4.83	1.46	0.09
	σ	0.56	0.56	0.56	0.17	0.01
	V, %	11.65	11.66	11.68	11.62	11.24
March	\bar{X}	5.57	5.59	5.58	1.71	0.11
	σ	0.55	0.55	0.55	0.17	0.01
	V, %	9.86	9.86	9.87	10.09	10.35
April	\bar{X}	5.96	6.01	6.10	1.92	0.12
	σ	0.31	0.31	0.31	0.09	0.01
	V, %	5.13	5.14	5.07	4.86	4.70
May	\bar{X}	5.58	5.65	5.83	1.94	0.13
	σ	0.54	0.54	0.57	0.20	0.01
	V, %	9.60	9.61	9.69	10.11	10.58
June	\bar{X}	5.29	5.36	5.57	1.92	0.13
	σ	0.31	0.31	0.32	0.11	0.01
	V, %	5.82	5.82	5.83	5.88	6.01
Year	\bar{X}	4.96	5.00	5.07	1.61	0.10
	σ	0.24	0.25	0.25	0.08	0.01
	V, %	4.93	4.93	4.93	5.07	5.21

°C/hr = (°F/hr)/1.8

Table 33

Average Length of Freezing Period for Roof System 3B, Days

Building Identification		3				
Roofing Layer		Light Colored Gravel		Built-Up Roofing	Urethane Board	Gypsum Plank
Depth in Section (in.)		0.0	0.5	1.0	4.5	7.0
July	\bar{X}	---	---	---	---	---
	σ	---	---	---	---	---
	V, %	---	---	---	---	---
August	\bar{X}	---	---	---	---	---
	σ	---	---	---	---	---
	V, %	---	---	---	---	---
September	\bar{X}	---	---	---	---	---
	σ	---	---	---	---	---
	V, %	---	---	---	---	---
October	\bar{X}	---	---	---	---	---
	σ	---	---	---	---	---
	V, %	---	---	---	---	---
November	\bar{X}	0.10	0.11	0.07	---	---
	σ	0.09	0.09	0.07	---	---
	V, %	90.00	81.82	100.00	---	---
December	\bar{X}	0.13	0.13	0.12	---	---
	σ	0.05	0.04	0.03	---	---
	V, %	41.82	30.77	25.00	---	---
January	\bar{X}	0.24	0.25	0.21	---	---
	σ	0.11	0.10	0.11	---	---
	V, %	44.62	40.00	52.38	---	---
February	\bar{X}	0.16	0.16	0.15	---	---
	σ	0.03	0.03	0.04	---	---
	V, %	16.49	18.75	2.67	---	---
March	\bar{X}	0.10	0.10	0.09	---	---
	σ	0.04	0.04	0.03	---	---
	V, %	45.35	40.00	33.33	---	---
April	\bar{X}	0.04	0.04	0.03	---	---
	σ	0.05	0.05	0.04	---	---
	V, %	129.42	125.00	133.33	---	---
May	\bar{X}	---	---	---	---	---
	σ	---	---	---	---	---
	V, %	---	---	---	---	---
June	\bar{X}	---	---	---	---	---
	σ	---	---	---	---	---
	V, %	---	---	---	---	---
Year	\bar{X}	0.16	0.16	0.14	---	---
	σ	0.02	0.02	0.03	---	---
	V, %	12.76	12.50	21.43	---	---

Table 34

Average Length of Thawing Period for Roof System 3B, Days

Building Identification		3							
Roofing Layer		Light Colored Gravel	0.5	Built-Up Roofing	1.0	Urethane Board	4.5	Gypsum Plank	7.0
Depth in Section (in.)		0.0	0.5	1.0	4.5	7.0			
July	\bar{X}	---	---	---	---	---			
	σ								
	V, %								
August	\bar{X}	---	---	---	---	---			
	σ								
	V, %								
September	\bar{X}	---	---	---	---	---			
	σ								
	V, %								
October	\bar{X}	---	---	---	---	---			
	σ								
	V, %								
November	\bar{X}	12.34	13.22	14.01					
	σ	9.30	8.96	9.04					
	V, %	75.39	67.78	64.52					
December	\bar{X}	5.50	5.63	6.65					
	σ	5.16	5.11	4.52					
	V, %	93.88	90.76	67.97					
January	\bar{X}	2.55	2.62	2.77					
	σ	2.43	2.41	2.38					
	V, %	95.30	91.98	85.92					
February	\bar{X}	2.14	2.24	3.16					
	σ	0.90	0.94	1.70					
	V, %	42.03	41.96	53.79					
March	\bar{X}	4.37	4.49	5.66					
	σ	2.19	1.95	2.06					
	V, %	50.20	43.43	36.39					
April	\bar{X}	19.56	19.45	19.74					
	σ	11.48	11.25	11.19					
	V, %	58.69	57.79	56.69					
May	\bar{X}	---	---	---					
	σ								
	V, %								
June	\bar{X}	---	---	---					
	σ								
	V, %								
Year	\bar{X}	8.54	8.91	11.41					
	σ	4.42	4.20	4.81					
	V, %	51.78	47.14	42.16					

Table 35

Average Number of Freeze-Thaw Cycles for Roof System 3B

Building Identification		3				
Roofing Layer		Light Colored Gravel		Built-Up Roofing	Urethane Board	Gypsum Plank
Depth in Section (in.)		0.0	0.5	1.0	4.5	7.0
July	\bar{X}	---	---	---	---	---
	σ					
	V, %					
August	\bar{X}	---	---	---	---	---
	σ					
	V, %					
September	\bar{X}	---	---	---	---	---
	σ					
	V, %					
October	\bar{X}	---	---	---	---	---
	σ					
	V, %					
November	\bar{X}	2.33	2.33	1.83	0.00	0.00
	σ	1.63	1.63	1.60		
	V, %	69.99	69.99	87.39		
December	\bar{X}	8.17	8.33	6.50	0.00	0.00
	σ	5.60	5.72	4.93		
	V, %	68.58	68.59	75.84		
January	\bar{X}	15.00	14.67	14.00	0.00	0.00
	σ	6.93	6.83	6.23		
	V, %	46.19	46.58	44.49		
February	\bar{X}	13.00	12.67	11.50	0.00	0.00
	σ	5.37	5.72	5.47		
	V, %	45.12	45.12	47.55		
March	\bar{X}	7.67	7.50	6.00	0.00	0.00
	σ	4.68	4.89	3.85		
	V, %	60.09	65.18	64.12		
April	\bar{X}	1.17	1.17	1.00	0.00	0.00
	σ	1.33	1.33	1.26		
	V, %	113.93	113.93	126.49		
May	\bar{X}	---	---	---	---	---
	σ					
	V, %					
June	\bar{X}	---	---	---	---	---
	σ					
	V, %					
Year	\bar{X}	47.33	46.67	40.83	0.00	0.00
	σ	15.82	16.27	14.19		
	V, %	33.42	34.86	34.75		

Table 36

Average Temperature Above Freezing for Roof System 4A, °F

Building Identification		4			
Roofing Layer		GAF Mineral Shield		Urethane Board	Gypsum Plank
Depth in Section (in.)		0.0	0.5	1.0	2.5
July	\bar{X}	93.59	91.67	83.81	73.98
	σ	1.95	1.76	1.06	0.19
	V, %	2.08	1.92	1.26	0.25
August	\bar{X}	91.74	90.04	82.92	73.92
	σ	2.34	2.15	1.31	0.25
	V, %	2.55	2.39	1.58	0.34
September	\bar{X}	83.79	83.11	78.82	73.24
	σ	2.51	2.37	1.47	0.29
	V, %	2.99	2.85	1.86	0.39
October	\bar{X}	75.02	75.03	73.87	72.32
	σ	1.83	1.73	1.07	0.22
	V, %	2.44	2.30	1.44	0.30
November	\bar{X}	62.54	63.05	65.95	70.80
	σ	1.91	1.67	1.34	0.28
	V, %	3.05	2.64	2.04	0.39
December	\bar{X}	58.47	58.50	62.71	70.19
	σ	2.79	3.07	2.24	0.43
	V, %	4.77	5.25	3.57	0.62
January	\bar{X}	56.19	55.85	59.42	69.57
	σ	1.98	2.44	2.50	0.49
	V, %	3.53	4.36	4.21	0.70
February	\bar{X}	58.66	58.65	60.76	69.82
	σ	3.03	2.97	1.58	0.31
	V, %	5.16	5.06	2.60	0.44
March	\bar{X}	64.00	64.14	65.75	70.76
	σ	2.07	1.94	1.68	0.33
	V, %	3.23	3.02	2.55	0.46
April	\bar{X}	71.84	71.35	71.24	71.75
	σ	1.69	1.60	1.28	0.26
	V, %	2.36	2.24	1.79	0.37
May	\bar{X}	81.35	80.05	76.66	72.64
	σ	2.10	1.91	1.16	0.21
	V, %	2.58	2.39	1.51	0.29
June	\bar{X}	90.51	88.69	81.92	73.57
	σ	1.95	1.82	1.12	0.22
	V, %	2.16	2.06	1.36	0.30
Year	\bar{X}	74.85	74.00	72.05	71.89
	σ	0.54	0.44	0.51	0.14
	V, %	0.72	0.60	0.70	0.20

$$^{\circ}\text{C} = (^{\circ}\text{F} - 32)/1.8$$

Table 37

Average Temperature Below Freezing for Roof System 4A, °F

Building Identification		4			
Roofing Layer		GAF Mineral Shield		Urethane Board	Gypsum Plank
Depth in Section (in.)		0.0	0.5	1.0	2.5
July	\bar{X}	---	---	---	---
	σ	---	---	---	---
	V, %	---	---	---	---
August	\bar{X}	---	---	---	---
	σ	---	---	---	---
	V, %	---	---	---	---
September	\bar{X}	---	---	---	---
	σ	---	---	---	---
	V, %	---	---	---	---
October	\bar{X}	---	---	---	---
	σ	---	---	---	---
	V, %	---	---	---	---
November	\bar{X}	28.02	29.40	---	---
	σ	2.54	0.63	---	---
	V, %	9.08	2.17	---	---
December	\bar{X}	28.16	29.14	---	---
	σ	1.84	0.83	---	---
	V, %	6.54	2.86	---	---
January	\bar{X}	26.33	27.56	---	---
	σ	3.23	2.67	---	---
	V, %	12.26	10.44	---	---
February	\bar{X}	26.74	27.73	---	---
	σ	1.45	2.59	---	---
	V, %	5.43	9.41	---	---
March	\bar{X}	27.64	29.05	---	---
	σ	0.96	2.09	---	---
	V, %	3.48	7.19	---	---
April	\bar{X}	28.82	29.57	---	---
	σ	0.16	0.19	---	---
	V, %	0.56	0.65	---	---
May	\bar{X}	---	---	---	---
	σ	---	---	---	---
	V, %	---	---	---	---
June	\bar{X}	---	---	---	---
	σ	---	---	---	---
	V, %	---	---	---	---
Year	\bar{X}	27.17	28.16	---	---
	σ	1.08	2.92	---	---
	V, %	3.96	10.53	---	---

$$^{\circ}\text{C} = (^{\circ}\text{F} - 32)/1.8$$

Table 38

Average Cooling Rate for Roof System 4A, °F/hr

Building Identification		4			
Roofing Layer		GAF Mineral Shield		Urethane Board	Gypsum Plank
Depth in Section (in.)		0.0	0.5	1.0	2.5
July	\bar{X}	2.13	2.17	1.38	0.28
	σ	0.19	0.20	0.13	0.03
	V,%	9.07	9.16	9.25	9.65
August	\bar{X}	2.32	2.34	1.47	0.29
	σ	0.21	0.21	0.14	0.03
	V,%	8.95	9.10	9.21	9.71
September	\bar{X}	2.43	2.38	1.48	0.27
	σ	0.17	0.17	0.10	0.02
	V,%	6.99	7.01	7.05	7.28
October	\bar{X}	2.11	2.05	1.26	0.23
	σ	0.24	0.23	0.14	0.03
	V,%	11.28	11.28	11.31	11.49
November	\bar{X}	2.03	1.99	1.23	0.22
	σ	0.15	0.15	0.09	0.02
	V,%	7.49	7.52	7.53	7.55
December	\bar{X}	1.78	1.74	1.08	0.19
	σ	0.20	0.19	0.12	0.02
	V,%	11.05	11.02	11.02	11.03
January	\bar{X}	1.82	1.78	1.10	0.20
	σ	0.15	0.15	0.09	0.02
	V,%	8.52	8.53	8.59	9.01
February	\bar{X}	2.18	2.13	1.31	0.24
	σ	0.24	0.24	0.15	0.03
	V,%	11.19	11.20	11.19	11.15
March	\bar{X}	2.54	2.47	1.53	0.28
	σ	0.24	0.24	0.15	0.03
	V,%	9.59	9.59	9.61	9.73
April	\bar{X}	2.62	2.62	1.64	0.31
	σ	0.18	0.18	0.11	0.02
	V,%	6.82	6.74	6.70	6.51
May	\bar{X}	2.40	2.44	1.54	0.31
	σ	0.21	0.21	0.14	0.03
	V,%	8.56	8.69	8.79	9.20
June	\bar{X}	2.24	2.28	1.45	0.30
	σ	0.12	0.13	0.08	0.02
	V,%	5.53	5.58	5.60	5.72
Year	\bar{X}	2.22	2.20	1.37	0.26
	σ	0.11	0.11	0.07	0.01
	V,%	4.96	4.94	4.95	5.06

$$^{\circ}\text{C/hr} = (^{\circ}\text{F/hr})/1.8$$

Table 39

Average Warming Rate for Roof System 4A, °F/hr

Building Identification		4			
Roofing Layer		GAF Mineral Shield		Urethane Board	Gypsum Plank
Depth in Section (in.)		0.0	0.5	1.0	2.5
July	\bar{X}	4.27	4.35	2.77	0.56
	σ	0.36	0.38	0.24	0.05
	V, %	8.50	8.62	8.71	9.13
August	\bar{X}	4.62	4.67	2.94	0.57
	σ	0.40	0.41	0.26	0.05
	V, %	8.68	8.85	8.96	9.48
September	\bar{X}	4.82	4.72	2.92	0.54
	σ	0.34	0.34	0.21	0.04
	V, %	7.16	7.18	7.21	7.42
October	\bar{X}	4.17	4.05	2.51	0.46
	σ	0.44	0.42	0.26	0.05
	V, %	10.47	10.48	10.51	10.68
November	\bar{X}	4.00	3.91	2.41	0.44
	σ	0.32	0.31	0.19	0.04
	V, %	8.02	8.04	8.04	8.03
December	\bar{X}	3.56	3.49	2.15	0.39
	σ	0.37	0.36	0.22	0.04
	V, %	10.27	10.27	10.27	10.27
January	\bar{X}	3.63	3.54	2.19	0.40
	σ	0.33	0.32	0.20	0.04
	V, %	9.02	9.00	9.05	9.43
February	\bar{X}	4.41	4.30	2.65	0.48
	σ	0.52	0.50	0.31	0.06
	V, %	11.75	11.75	11.74	11.71
March	\bar{X}	5.08	4.94	3.05	0.56
	σ	0.51	0.49	0.31	0.06
	V, %	9.97	9.98	10.00	10.17
April	\bar{X}	5.30	5.30	3.31	0.62
	σ	0.28	0.28	0.18	0.03
	V, %	5.33	5.32	5.29	5.13
May	\bar{X}	4.83	4.91	3.10	0.62
	σ	0.46	0.47	0.30	0.06
	V, %	9.51	9.58	9.65	9.98
June	\bar{X}	4.52	4.61	2.94	0.60
	σ	0.27	0.27	0.17	0.04
	V, %	5.87	5.88	5.88	5.91
Year	\bar{X}	4.43	4.40	2.74	0.52
	σ	0.22	0.22	0.14	0.03
	V, %	4.96	4.95	4.95	5.06

$$^{\circ}\text{C/hr} = (^{\circ}\text{F/hr})1.8$$

Table 40

Average Length of Freezing Period for Roof System 4A, Days

Building Identification		4			
Roofing Layer		GAF Mineral Shield	Urethane Board	Gypsum Plank	
Depth in Section (in.)		0.0	0.5	1.0	2.5
July	\bar{X} σ V, %	---	---	---	---
August	\bar{X} σ V, %				
September	\bar{X} σ V, %				
October	\bar{X} σ V, %				
November	\bar{X} σ V, %	0.07 0.07 100.00	---	---	---
December	\bar{X} σ V, %	0.11 0.05 48.10	---	---	---
January	\bar{X} σ V, %	0.18 0.10 56.37	---	---	---
February	\bar{X} σ V, %	0.13 0.04 28.64	---	---	---
March	\bar{X} σ V, %	0.07 0.04 60.44			
April	\bar{X} σ V, %	0.02 0.03 168.57	---	---	---
May	\bar{X} σ V, %				
June	\bar{X} σ V, %				
Year	\bar{X} σ V, %	0.13 0.03 20.89			

Table 41

Average Length of Thawing Period for Roof System 4A, Days

Building Identification		4			
Roofing Layer		GAF Mineral Shield	Urethane Board	Gypsum Plank	
Depth in Section (in.)		0.0	0.5	1.0	2.5
July	\bar{X} σ V, %				
August	\bar{X} σ V, %				
September	\bar{X} σ V, %				
October	\bar{X} σ V, %				
November	\bar{X} σ V, %	15.54 11.31 72.78			
December	\bar{X} σ V, %	7.28 4.98 68.38	---	---	---
January	\bar{X} σ V, %	2.83 2.32 81.98	---	---	---
February	\bar{X} σ V, %	2.81 1.27 45.09	---	---	---
March	\bar{X} σ V, %	9.46 10.69 113.03	---	---	---
April	\bar{X} σ V, %	24.15 9.19 38.08	---	---	---
May	\bar{X} σ V, %				
June	\bar{X} σ V, %				
Year	\bar{X} σ V, %	11.22 5.30 47.21			

Table 42

Average Number of Freeze-Thaw Cycles for Roof System 4A

Building Identification		4				
Roofing Layer		GAF Mineral Shield		Urethane Board	Gypsum Plank	
Depth in Section (in.)		0.0	0.5	1.0	2.5	
July	\bar{X}	---	---	---	---	---
	σ					
	V, %					
August	\bar{X}	---	---	---	---	---
	σ					
	V, %					
September	\bar{X}	---	---	---	---	---
	σ					
	V, %					
October	\bar{X}	---	---	---	---	---
	σ					
	V, %					
November	\bar{X}	1.83	1.50	0.00	0.00	0.00
	σ	1.60	1.38			
	V, %	87.39	91.89			
December	\bar{X}	5.33	3.33	0.00	0.00	0.00
	σ	4.23	2.66			
	V, %	79.25	79.75			
January	\bar{X}	12.67	9.50	0.00	0.00	0.00
	σ	5.32	3.94			
	V, %	41.97	41.44			
February	\bar{X}	10.33	8.50	0.00	0.00	0.00
	σ	5.47	5.47			
	V, %	52.89	64.33			
March	\bar{X}	4.83	4.00	0.00	0.00	0.00
	σ	3.66	2.90			
	V, %	75.64	72.46			
April	\bar{X}	0.50	0.50	0.00	0.00	0.00
	σ	0.34	0.34			
	V, %	67.33	67.33			
May	\bar{X}	---	---	---	---	---
	σ					
	V, %					
June	\bar{X}	---	---	---	---	---
	σ					
	V, %					
Year	\bar{X}	26.50	27.33	0.00	0.00	0.00
	σ	1.69	1.38			
	V, %	32.93	30.67			

Table 43

Average Temperature Above Freezing for Roof System 4B, °F

Building Identification		Roofing Layer				
		GAF Mineral Shield		Urethane Board		Gypsum Plank
Depth in Section (in.)		0.0	0.5	1.5	4.0	6.5
July	\bar{X}	94.05	92.88	87.85	78.07	72.44
	σ	1.98	1.86	1.40	0.55	0.08
	V, %	2.10	2.00	1.60	0.70	0.12
August	\bar{X}	92.19	91.20	86.92	77.92	72.42
	σ	2.39	2.29	1.81	0.75	0.12
	V, %	2.60	2.51	2.09	0.96	0.16
September	\bar{X}	84.08	83.87	81.56	75.82	72.24
	σ	2.57	2.54	2.06	0.87	0.13
	V, %	3.05	3.02	2.53	1.15	0.18
October	\bar{X}	75.09	75.24	74.65	72.94	72.00
	σ	1.88	1.85	1.50	0.64	0.11
	V, %	2.51	2.46	2.01	0.88	0.15
November	\bar{X}	62.87	62.69	63.58	68.22	71.60
	σ	1.81	1.79	1.80	0.82	0.09
	V, %	2.91	2.84	2.84	1.20	0.12
December	\bar{X}	58.76	59.16	59.04	66.37	71.45
	σ	2.75	2.78	3.13	1.33	0.15
	V, %	4.68	4.70	5.29	2.01	0.21
January	\bar{X}	56.39	56.73	55.30	64.38	71.29
	σ	1.82	1.67	3.13	1.47	0.16
	V, %	3.22	2.95	5.66	2.29	0.22
February	\bar{X}	58.92	59.28	57.22	65.15	71.34
	σ	3.32	3.54	2.30	0.91	0.12
	V, %	5.63	5.98	4.02	1.40	0.17
March	\bar{X}	64.17	64.47	63.36	68.08	71.58
	σ	1.96	1.92	2.37	0.99	0.13
	V, %	3.05	2.98	3.74	1.46	0.18
April	\bar{X}	71.89	71.47	70.64	71.14	71.84
	σ	1.58	1.68	1.81	0.78	0.08
	V, %	2.19	2.35	2.56	1.10	0.12
May	\bar{X}	81.49	80.46	77.83	73.92	72.08
	σ	2.14	2.03	1.56	0.63	0.08
	V, %	2.62	2.52	2.01	0.85	0.12
June	\bar{X}	90.87	89.65	85.05	76.79	72.32
	σ	2.00	1.94	1.54	0.63	0.08
	V, %	2.20	2.16	1.81	0.82	0.11
Year	\bar{X}	75.17	74.84	72.11	71.60	71.89
	σ	0.70	0.60	0.59	0.32	0.09
	V, %	0.93	0.80	0.82	0.44	0.13

$$^{\circ}\text{C} = (^{\circ}\text{F} - 32)/1.8$$

Table 44

Average Temperature Below Freezing for Roof System 4B, °F

Building Identification		4				
Roofing Layer		GAF Mineral Shield		Urethane Board	Gypsum Plank	
Depth in Section (in.)		0.0	0.5	1.5	4.0	6.5
July	\bar{X}	---	---	---	---	---
	σ	---	---	---	---	---
	V, %	---	---	---	---	---
August	\bar{X}	---	---	---	---	---
	σ	---	---	---	---	---
	V, %	---	---	---	---	---
September	\bar{X}	---	---	---	---	---
	σ	---	---	---	---	---
	V, %	---	---	---	---	---
October	\bar{X}	---	---	---	---	---
	σ	---	---	---	---	---
	V, %	---	---	---	---	---
November	\bar{X}	27.12	27.15	30.63	---	---
	σ	2.82	2.85	0.00	---	---
	V, %	10.39	10.49	0.00	---	---
December	\bar{X}	27.92	29.24	31.04	---	---
	σ	1.16	1.00	0.88	---	---
	V, %	4.16	3.55	2.83	---	---
January	\bar{X}	25.42	25.64	28.75	---	---
	σ	3.30	3.22	1.54	---	---
	V, %	12.97	12.56	5.36	---	---
February	\bar{X}	26.12	26.17	29.89	---	---
	σ	1.54	1.25	0.92	---	---
	V, %	5.88	4.78	3.08	---	---
March	\bar{X}	27.58	27.76	30.76	---	---
	σ	1.72	1.74	1.50	---	---
	V, %	6.22	6.28	4.89	---	---
April	\bar{X}	28.41	28.56	---	---	---
	σ	1.29	2.34	---	---	---
	V, %	4.54	8.18	---	---	---
May	\bar{X}	---	---	---	---	---
	σ	---	---	---	---	---
	V, %	---	---	---	---	---
June	\bar{X}	---	---	---	---	---
	σ	---	---	---	---	---
	V, %	---	---	---	---	---
Year	\bar{X}	26.51	26.63	29.78	---	---
	σ	1.07	1.04	1.28	---	---
	V, %	4.03	3.91	4.31	---	---

$$^{\circ}\text{C} = (^{\circ}\text{F} - 32)/1.8$$

Table 45

Average Cooling Rate for Roof System 4B, °F/hr

Building Identification		4				
Roofing Layer		GAF Mineral Shield		Urethane Board	Gypsum Plank	
Depth in Section (in.)		0.0	0.5	1.5	4.0	6.5
July	\bar{X}	2.20	2.34	2.04	0.87	0.06
	σ	0.20	0.21	0.19	0.08	0.01
	V, %	9.04	9.15	9.34	9.66	10.23
August	\bar{X}	2.39	2.52	2.14	0.88	0.06
	σ	0.21	0.23	0.20	0.09	0.01
	V, %	8.89	9.05	9.30	9.71	10.55
September	\bar{X}	2.50	2.55	2.09	0.84	0.06
	σ	0.17	0.18	0.15	0.06	0.00
	V, %	6.96	6.99	7.07	7.29	7.85
October	\bar{X}	2.16	2.19	1.79	0.71	0.05
	σ	0.24	0.25	0.20	0.08	0.01
	V, %	11.23	11.23	11.30	11.47	11.84
November	\bar{X}	2.09	2.13	1.74	0.68	0.04
	σ	0.16	0.16	0.13	0.05	0.00
	V, %	7.45	7.49	7.52	7.51	7.44
December	\bar{X}	1.83	1.87	1.52	0.60	0.04
	σ	0.20	0.21	0.17	0.07	0.00
	V, %	11.07	11.04	11.02	11.06	11.37
January	\bar{X}	1.87	1.90	1.56	0.61	0.04
	σ	0.16	0.16	0.14	0.06	0.00
	V, %	8.52	8.54	8.69	9.06	9.84
February	\bar{X}	2.25	2.28	1.86	0.74	0.05
	σ	0.25	0.26	0.21	0.08	0.01
	V, %	11.20	11.21	11.20	11.16	11.11
March	\bar{X}	2.61	2.65	2.16	0.86	0.06
	σ	0.25	0.25	0.21	0.08	0.01
	V, %	9.58	9.59	9.62	9.75	10.08
April	\bar{X}	2.70	2.81	2.34	0.94	0.06
	σ	0.18	0.19	0.16	0.06	0.00
	V, %	6.81	6.72	6.62	6.47	6.20
May	\bar{X}	2.47	2.63	2.26	0.95	0.06
	σ	0.21	0.23	0.20	0.09	0.01
	V, %	8.57	8.71	8.93	9.23	9.69
June	\bar{X}	2.31	2.46	2.16	0.93	0.07
	σ	0.13	0.14	0.12	0.05	0.00
	V, %	5.52	5.57	5.63	5.71	5.83
Year	\bar{X}	2.28	2.36	1.97	0.80	0.05
	σ	0.11	0.12	0.10	0.04	0.00
	V, %	4.95	4.94	4.97	5.07	5.40

$$^{\circ}\text{C/hr} = (^{\circ}\text{F/hr})/1.8$$

Table 46

Average Warming Rate for Roof System 4B, °F/hr

Building Identification		4				
Roofing Layer		GAF Mineral Shield		Urethane Board		Gypsum Plank
Depth in Section (in.)		0.0	0.5	1.5	4.0	6.5
July	\bar{X}	4.40	4.69	4.09	1.74	0.12
	σ	0.37	0.40	0.36	0.16	0.01
	V, %	8.48	8.61	8.82	9.14	9.66
August	\bar{X}	4.75	5.02	4.26	1.75	0.12
	σ	0.41	0.44	0.39	0.17	0.01
	V, %	8.62	8.80	9.06	9.48	10.32
September	\bar{X}	4.95	5.05	4.14	1.66	0.11
	σ	0.35	0.36	0.30	0.12	0.01
	V, %	7.14	7.16	7.23	7.43	7.97
October	\bar{X}	4.28	4.34	3.55	1.42	0.09
	σ	0.45	0.45	0.37	0.15	0.01
	V, %	10.42	10.43	10.50	10.66	10.98
November	\bar{X}	4.11	4.19	3.42	1.34	0.08
	σ	0.33	0.34	0.27	0.11	0.01
	V, %	7.99	8.01	8.02	7.99	8.00
December	\bar{X}	3.67	3.74	3.05	1.19	0.07
	σ	0.38	0.38	0.31	0.12	0.01
	V, %	10.29	10.29	10.28	10.29	10.39
January	\bar{X}	3.73	3.80	3.10	1.22	0.07
	σ	0.34	0.34	0.28	0.12	0.01
	V, %	9.02	9.01	9.13	9.49	10.40
February	\bar{X}	4.54	4.61	3.76	1.49	0.09
	σ	0.53	0.54	0.44	0.17	0.01
	V, %	11.76	11.76	11.74	11.72	11.72
March	\bar{X}	5.23	5.29	4.32	1.72	0.11
	σ	0.52	0.53	0.43	0.18	0.01
	V, %	9.97	9.98	10.03	10.19	10.62
April	\bar{X}	5.45	5.69	4.73	1.91	0.13
	σ	0.29	0.30	0.25	0.10	0.01
	V, %	5.31	5.29	5.24	5.08	4.76
May	\bar{X}	4.98	5.29	4.55	1.90	0.13
	σ	0.47	0.51	0.44	0.19	0.01
	V, %	9.51	9.59	9.75	10.00	10.43
June	\bar{X}	4.66	4.98	4.36	1.87	0.13
	σ	0.27	0.29	0.26	0.11	0.01
	V, %	5.86	5.87	5.88	5.90	5.97
Year	\bar{X}	4.56	4.72	3.95	1.60	0.11
	σ	0.23	0.23	0.20	0.08	0.01
	V, %	4.96	4.95	4.97	5.07	5.27

$$^{\circ}\text{C/hr} = (^{\circ}\text{F/hr})/1.8$$

Table 47

Average Length of Freezing Period for Roof System 4B, Days

Building Identification		4				
Roofing Layer		GAF Mineral Shield		Urethane Board	Gypsum Plank	
Depth in Section (in.)		0.0	0.5	1.5	4.0	6.5
July	\bar{X}	---	---	---	---	---
	σ					
	V, %					
August	\bar{X}	---	---	---	---	---
	σ					
	V, %					
September	\bar{X}	---	---	---	---	---
	σ					
	V, %					
October	\bar{X}	---	---	---	---	---
	σ					
	V, %					
November	\bar{X}	0.08				
	σ	0.08				
	V, %	100.00				
December	\bar{X}	0.11				
	σ	0.03				
	V, %	24.17				
January	\bar{X}	0.20				
	σ	0.10				
	V, %	50.00				
February	\bar{X}	0.14				
	σ	0.04				
	V, %	25.02				
March	\bar{X}	0.09				
	σ	0.03				
	V, %	38.76				
April	\bar{X}	0.02				
	σ	0.04				
	V, %	181.94				
May	\bar{X}	---	---	---	---	---
	σ					
	V, %					
June	\bar{X}	---	---	---	---	---
	σ					
	V, %					
Year	\bar{X}	0.15				
	σ	0.03				
	V, %	19.23				

Table 48

Average Length of Thawing Period for Roof System 4B, Days

Building Identification		4				
Roofing Layer		GAF Mineral Shield		Urethane Board		Gypsum Plank
Depth in Section (in.)		0.0	0.5	1.5	4.0	6.5
July	\bar{X}	---	---	---	---	---
	σ	---	---	---	---	---
	V,%	---	---	---	---	---
August	\bar{X}	---	---	---	---	---
	σ	---	---	---	---	---
	V,%	---	---	---	---	---
September	\bar{X}	---	---	---	---	---
	σ	---	---	---	---	---
	V,%	---	---	---	---	---
October	\bar{X}	---	---	---	---	---
	σ	---	---	---	---	---
	V,%	---	---	---	---	---
November	\bar{X}	15.11	---	---	---	---
	σ	11.61	---	---	---	---
	V,%	76.82	---	---	---	---
December	\bar{X}	6.29	---	---	---	---
	σ	4.99	---	---	---	---
	V,%	79.41	---	---	---	---
January	\bar{X}	2.70	---	---	---	---
	σ	2.37	---	---	---	---
	V,%	88.13	---	---	---	---
February	\bar{X}	2.48	---	---	---	---
	σ	1.03	---	---	---	---
	V,%	41.40	---	---	---	---
March	\bar{X}	6.54	---	---	---	---
	σ	4.62	---	---	---	---
	V,%	70.71	---	---	---	---
April	\bar{X}	23.32	---	---	---	---
	σ	10.35	---	---	---	---
	V,%	44.39	---	---	---	---
May	\bar{X}	---	---	---	---	---
	σ	---	---	---	---	---
	V,%	---	---	---	---	---
June	\bar{X}	---	---	---	---	---
	σ	---	---	---	---	---
	V,%	---	---	---	---	---
Year	\bar{X}	10.14	---	---	---	---
	σ	5.19	---	---	---	---
	V,%	51.19	---	---	---	---

Table 49

Average Number of Freeze-Thaw Cycles for Roof System 4B

Building Identification		4				
Roofing Layer		GAF Mineral Shield		Urethane Board	Gypsum Plank	
Depth in Section (in.)		0.0	0.5	1.5	4.0	6.5
July	\bar{X}	---	---	---	---	---
	σ					
	V, %					
August	\bar{X}	---	---	---	---	---
	σ					
	V, %					
September	\bar{X}	---	---	---	---	---
	σ					
	V, %					
October	\bar{X}	---	---	---	---	---
	σ					
	V, %					
November	\bar{X}	2.00	2.00	0.17	0.00	0.00
	σ	1.67	1.67	0.41		
	V, %	83.67	83.67	244.95		
December	\bar{X}	6.67	6.67	0.33	0.00	0.00
	σ	5.16	4.84	0.52		
	V, %	77.46	77.66	154.92		
January	\bar{X}	13.83	13.50	2.33	0.00	0.00
	σ	6.34	6.06	3.88		
	V, %	45.81	44.87	166.35		
February	\bar{X}	11.33	11.00	2.17	0.00	0.00
	σ	5.39	5.76	1.47		
	V, %	47.57	52.38	67.94		
March	\bar{X}	5.50	5.50	0.33	0.00	0.00
	σ	4.04	3.73	0.52		
	V, %	73.41	67.79	154.92		
April	\bar{X}	0.67	0.83	0.00	0.00	0.00
	σ	1.03	0.98	0.00		
	V, %	154.92	117.98	0.00		
May	\bar{X}	---	---	---	---	---
	σ					
	V, %					
June	\bar{X}	---	---	---	---	---
	σ					
	V, %					
Year	\bar{X}	40.00	39.50	5.33	0.00	0.00
	σ	13.64	13.72	3.98		
	V, %	34.10	34.74	74.69		

Table 50

Average Temperature Above Freezing for Roof System 34, °F

Building Identification		34			34	
Roofing Layer		EPDM Elastomer	Urethane	Gypsum Plank	EPDM Elastomer	Fiberglass
Depth in Section (in.)		0.0	1.0	3.0	0.0	1.0
July	\bar{X}	96.95	85.37	73.29	95.78	83.46
	σ	2.56	1.37	0.15	2.13	1.02
	V,%	2.64	1.60	0.20	2.22	1.22
August	\bar{X}	93.90	83.72	73.20	93.53	82.31
	σ	3.22	1.74	0.19	2.47	1.18
	V,%	3.42	2.07	0.26	2.64	1.44
September	\bar{X}	83.76	78.46	72.71	84.52	78.15
	σ	3.02	1.70	0.23	2.46	1.23
	V,%	3.61	2.17	0.31	2.91	1.57
October	\bar{X}	74.05	73.32	72.14	75.13	73.70
	σ	1.32	0.75	0.10	1.75	0.87
	V,%	1.78	1.02	0.13	2.33	1.18
November	\bar{X}	61.35	64.83	71.13	62.57	66.93
	σ	1.86	1.49	0.19	1.77	1.12
	V,%	3.03	2.30	0.27	2.82	1.67
December	\bar{X}	57.23	60.62	70.64	58.63	64.13
	σ	1.98	1.58	0.20	2.57	1.87
	V,%	3.45	2.60	0.23	4.38	2.92
January	\bar{X}	55.79	57.07	70.23	56.53	61.37
	σ	2.82	1.14	0.15	1.90	2.10
	V,%	4.35	1.99	0.22	3.36	3.42
February	\bar{X}	59.43	59.53	70.52	59.46	62.60
	σ	4.11	1.89	0.22	3.02	1.33
	V,%	6.91	3.17	0.32	5.07	2.12
March	\bar{X}	64.76	64.05	71.04	64.77	66.91
	σ	3.55	1.74	0.23	2.04	1.41
	V,%	5.48	2.72	0.32	3.15	2.10
April	\bar{X}	70.75	70.48	71.69	73.38	72.09
	σ	1.31	1.12	0.17	1.69	1.09
	V,%	1.86	1.59	0.24	2.30	1.51
May	\bar{X}	81.14	76.36	72.25	83.22	77.13
	σ	1.69	0.94	0.11	2.31	1.11
	V,%	2.09	1.24	0.16	2.77	1.44
June	\bar{X}	90.00	81.39	72.79	92.28	81.68
	σ	1.46	0.77	0.10	2.02	0.99
	V,%	1.62	0.94	0.14	2.19	1.22
Year	\bar{X}	75.60	71.34	71.81	75.91	72.60
	σ	0.69	0.38	0.08	0.71	0.44
	V,%	0.91	0.54	0.11	0.94	0.60

$$^{\circ}\text{C} = (^{\circ}\text{F} - 32)/1.8$$

Table 51

Average Temperature Below Freezing for Roof System 34, °F

Building Identification		34			34	
Roofing Layer		EPDM Elastomer	Urethane	Gypsum Plank	E. Elastomer	Fiberglass
Depth in Section (in.)		0.0	1.0	3.0	0.0	1.0
July	\bar{X} σ V, %	---	---	---	---	---
August	\bar{X} σ V, %	---	---	---	---	---
September	\bar{X} σ V, %	---	---	---	---	---
October	\bar{X} σ V, %	---	---	---	---	---
November	\bar{X} σ V, %	27.73 3.24 11.68	---	---	27.64 2.32 8.41	---
December	\bar{X} σ V, %	27.10 1.16 4.28	---	---	28.09 1.82 6.48	---
January	\bar{X} σ V, %	24.48 2.62 10.70	---	---	26.05 3.28 12.59	---
February	\bar{X} σ V, %	24.70 1.98 8.03	---	---	26.69 1.50 5.63	---
March	\bar{X} σ V, %	26.29 1.30 4.95	---	---	28.18 2.11 7.48	---
April	\bar{X} σ V, %	28.94 0.00 0.00	---	---	30.47 0.00 0.00	---
May	\bar{X} σ V, %	---	---	---	---	---
June	\bar{X} σ V, %	---	---	---	---	---
Year	\bar{X} σ V, %	25.49 0.79 3.08	---	---	27.04 1.26 4.66	---

$$^{\circ}\text{C} = (^{\circ}\text{F} - 32)/1.8$$

Table 52

Average Cooling Rate for Roof System 34, °F/hr

Building Identification		34			34	
Roofing Layer		EPDM Elastomer	Urethane	Gypsum Plank	EPDM Elastomer	Fiberglass
Depth in Section (in.)		0.0	1.0	3.0	0.0	1.0
July	\bar{X}	2.06	1.13	0.19	2.11	1.15
	σ	0.17	0.09	0.02	0.19	0.10
	V, %	8.23	8.41	9.25	8.95	9.04
August	\bar{X}	2.21	1.20	0.19	2.32	1.27
	σ	0.25	0.14	0.02	0.21	0.12
	V, %	11.23	11.41	10.28	9.10	9.24
September	\bar{X}	2.46	1.31	0.12	2.52	1.33
	σ	0.19	0.10	0.01	0.18	0.09
	V, %	7.77	7.78	6.53	7.08	7.12
October	\bar{X}	2.38	1.23	0.09	2.21	1.14
	σ	0.18	0.09	0.01	0.25	0.13
	V, %	7.40	7.40	6.50	11.37	11.35
November	\bar{X}	2.32	1.20	0.09	2.09	1.09
	σ	0.18	0.09	0.01	0.16	0.08
	V, %	7.68	7.66	6.01	7.43	7.45
December	\bar{X}	2.17	1.12	0.09	1.82	0.95
	σ	0.16	0.08	0.01	0.20	0.10
	V, %	7.51	7.60	5.96	10.94	10.90
January	\bar{X}	2.18	1.12	0.09	1.86	0.97
	σ	0.16	0.08	0.01	0.16	0.09
	V, %	7.18	7.21	9.55	8.82	8.80
February	\bar{X}	2.45	1.27	0.10	2.27	1.18
	σ	0.30	0.16	0.01	0.25	0.13
	V, %	12.25	12.26	13.70	11.05	11.05
March	\bar{X}	2.70	1.41	0.12	2.65	1.38
	σ	0.21	0.11	0.01	0.25	0.13
	V, %	7.91	7.91	11.29	9.59	9.61
April	\bar{X}	2.55	1.38	0.18	2.64	1.43
	σ	0.16	0.09	0.02	0.18	0.09
	V, %	6.32	6.35	9.77	6.72	6.61
May	\bar{X}	2.33	1.27	0.21	2.37	1.30
	σ	0.10	0.06	0.01	0.20	0.11
	V, %	4.26	4.38	4.95	8.44	8.58
June	\bar{X}	2.12	1.16	0.20	2.20	1.21
	σ	0.14	0.08	0.01	0.12	0.07
	V, %	6.72	6.77	7.09	5.41	5.45
Year	\bar{X}	2.33	1.23	0.13	2.25	1.20
	σ	0.06	0.03	0.00	0.11	0.06
	V, %	2.65	2.65	2.69	5.02	5.00

$$^{\circ}\text{C/hr} = (^{\circ}\text{F/hr})/1.8$$

Table 53

Average Warming Rate for Roof System 34, °F/hr

Building Identification		34			34	
		EPDM Elastomer	Urethane	Gypsum Plank	EPDM Elastomer	Fiberglass
Roofing Layer		0.0	1.0	3.0	0.0	1.0
Depth in Section (in.)		0.0	1.0	3.0	0.0	1.0
July	\bar{X}	5.10	2.96	0.17	4.22	2.31
	σ	0.46	0.27	0.02	0.35	0.20
	V, %	9.04	9.28	9.12	8.38	8.49
August	\bar{X}	5.51	3.07	0.15	4.62	2.52
	σ	0.69	0.39	0.02	0.41	0.23
	V, %	12.56	12.64	12.57	8.84	9.00
September	\bar{X}	5.35	2.43	0.17	4.99	2.63
	σ	0.46	0.19	0.02	0.36	0.19
	V, %	8.64	7.95	8.92	7.25	7.28
October	\bar{X}	2.76	1.58	0.16	4.39	2.27
	σ	0.21	0.12	0.02	0.46	0.24
	V, %	7.45	7.42	10.02	10.59	10.58
November	\bar{X}	2.69	1.54	0.15	4.12	2.14
	σ	0.22	0.12	0.01	0.33	0.17
	V, %	8.03	8.03	9.31	7.90	7.91
December	\bar{X}	2.49	1.42	0.13	3.63	1.90
	σ	0.16	0.09	0.01	0.37	0.19
	V, %	6.60	6.55	8.80	10.20	10.19
January	\bar{X}	2.46	1.41	0.13	3.72	1.94
	σ	0.18	0.11	0.01	0.34	0.18
	V, %	7.51	7.50	5.93	9.27	9.22
February	\bar{X}	2.90	1.66	0.16	4.58	2.37
	σ	0.42	0.24	0.02	0.53	0.27
	V, %	14.44	14.34	13.27	11.57	11.56
March	\bar{X}	4.42	2.11	0.19	5.31	2.75
	σ	0.41	0.19	0.01	0.53	0.28
	V, %	9.20	8.77	8.06	10.00	10.01
April	\bar{X}	6.36	3.31	0.17	5.33	2.89
	σ	0.43	0.19	0.01	0.28	0.15
	V, %	6.72	5.74	5.12	5.17	5.14
May	\bar{X}	5.81	3.33	0.19	4.78	2.61
	σ	0.29	0.17	0.01	0.45	0.25
	V, %	4.93	5.06	4.84	9.45	9.52
June	\bar{X}	5.26	3.06	0.19	4.46	2.44
	σ	0.39	0.23	0.01	0.25	0.14
	V, %	7.43	7.56	7.63	5.67	5.69
Year	\bar{X}	4.26	2.33	0.16	4.51	2.40
	σ	0.12	0.06	0.00	0.23	0.12
	V, %	2.74	2.70	2.62	5.03	5.00

$$^{\circ}\text{C/hr} = (^{\circ}\text{F/hr})/1.8$$

Table 54

Average Length of Freezing Period for Roof System 34, Days

Building Identification	34			34	
	EPDM Elastomer	Urethane	Gypsum Plank	EPDM Elastomer	Fiberglass
Roofing Layer	0.0	1.0	3.0	0.0	1.0
Depth in Section (in.)					
July	\bar{X} σ V, %	---	---	---	---
August	\bar{X} σ V, %	---	---	---	---
September	\bar{X} σ V, %	---	---	---	---
October	\bar{X} σ V, %	---	---	---	---
November	\bar{X} σ V, %	0.10 0.07 71.44	---	---	0.07 0.02 28.57
December	\bar{X} σ V, %	0.14 0.03 24.13	---	---	0.11 0.05 0.53
January	\bar{X} σ V, %	0.22 0.07 33.78	---	---	0.18 0.10 8.79
February	\bar{X} σ V, %	0.17 0.04 22.68	---	---	0.13 0.08 10.24
March	\bar{X} σ V, %	0.11 0.03 24.22	---	---	0.08 0.03 37.50
April	\bar{X} σ V, %	0.01 0.03 200.00	---	---	0.01 0.00 0.00
May	\bar{X} σ V, %	---	---	---	---
June	\bar{X} σ V, %	---	---	---	---
Year	\bar{X} σ V, %	0.17 0.02 10.64	---	---	0.13 0.10 72.66

Table 55

Average Length of Thawing Period for Roof System 34, Days

Building Identification		34			34	
Roofing Layer		EPDM Elastomer	Urethane	Gypsum Plank	EPDM Elastomer	Fiberglass
Depth in Section (in.)		0.0	1.0	3.0	0.0	1.0
July	\bar{X} σ V, %	---	---	---	---	---
August	\bar{X} σ V, %	---	---	---	---	---
September	\bar{X} σ V, %	---	---	---	---	---
October	\bar{X} σ V, %	---	---	---	---	---
November	\bar{X} σ V, %	6.49 2.46 37.85	---	---	16.37 5.87 66.38	---
December	\bar{X} σ V, %	2.61 1.15 44.12	---	---	7.24 4.74 77.56	---
January	\bar{X} σ V, %	1.26 0.25 19.85	---	---	2.85 2.92 102.48	---
February	\bar{X} σ V, %	1.68 0.53 31.28	---	---	2.57 2.81 105.26	---
March	\bar{X} σ V, %	2.75 1.12 40.69	---	---	6.84 6.33 99.17	---
April	\bar{X} σ V, %	24.99 10.02 40.09	---	---	24.16 5.00 38.84	---
May	\bar{X} σ V, %	---	---	---	---	---
June	\bar{X} σ V, %	---	---	---	---	---
Year	\bar{X} σ V, %	5.56 0.25 4.51	---	---	10.96 29.69 289.41	---

Table 56

Average Number of Freeze-Thaw Cycles for Roof System

Building Identification		34			34	
Roofing Layer		EPDM Elastomer	Urethane	Gypsum Plank	EPDM Elastomer	Fiberglass
Depth in Section (in.)		0.0	1.0	3.0	0.0	1.0
July	\bar{X}	---	---	---	---	---
	σ					
	V, %					
August	\bar{X}	---	---	---	---	---
	σ					
	V, %					
September	\bar{X}	---	---	---	---	---
	σ					
	V, %					
October	\bar{X}	---	---	---	---	---
	σ					
	V, %					
November	\bar{X}	4.00	0.00	0.00	1.67	0.00
	σ	1.63			1.63	
	V, %	40.32			97.26	
December	\bar{X}	11.50	0.00	0.00	5.50	0.00
	σ	3.79			4.51	
	V, %	32.92			81.92	
January	\bar{X}	20.50	0.00	0.00	12.67	0.00
	σ	3.42			5.47	
	V, %	16.66			43.15	
February	\bar{X}	15.25	0.00	0.00	10.83	0.00
	σ	5.32			5.04	
	V, %	34.85			46.49	
March	\bar{X}	11.00	0.00	0.00	5.17	0.00
	σ	3.92			3.76	
	V, %	35.60			72.85	
April	\bar{X}	0.50	0.00	0.00	0.50	0.00
	σ	1.00			0.84	
	V, %	200.00			167.33	
May	\bar{X}	---	---	---	---	---
	σ					
	V, %					
June	\bar{X}	---	---	---	---	---
	σ					
	V, %					
Year	\bar{X}	62.75	0.00	0.00	36.33	0.00
	σ	2.99			12.29	
	V, %	4.76			33.83	

Table 57

Transient Heat Flux, Btu/hr-sq ft

Building Identification	5	18	2	3	3	
Roofing Layer	Figure 1 5	Figure 2 18	Figure 3 2	Figure 4 3A	Figure 5 3B	
Depth in Section (in.)	Total	Total	Total	Total	Total	
July	\bar{X}	4.61	2.80	30.44	25.17	16.58
	σ	0.77	1.41	2.74	2.55	1.54
	V, %	16.64	50.33	9.01	10.13	9.30
August	\bar{X}	3.88	1.44	26.95	22.12	14.10
	σ	1.01	1.94	3.12	2.79	1.56
	V, %	25.96	134.46	11.56	12.62	11.06
September	\bar{X}	0.99	-6.22	12.49	11.05	5.74
	σ	1.00	2.54	3.06	2.65	1.24
	V, %	101.14	40.78	24.48	24.00	21.58
October	\bar{X}	-2.01	-14.92	-0.68	1.30	-0.45
	σ	0.44	2.16	2.52	1.72	1.04
	V, %	22.10	14.44	367.30	132.53	229.10
November	\bar{X}	-6.94	-28.35	-18.13	-12.65	-7.37
	σ	0.88	2.49	2.89	2.24	1.14
	V, %	12.66	8.64	15.93	17.69	15.47
December	\bar{X}	-9.37	-34.32	-25.47	-18.49	-10.26
	σ	0.93	4.28	5.33	3.92	2.15
	V, %	9.94	12.48	20.94	21.17	20.91
January	\bar{X}	-11.46	-40.72	-32.96	-23.73	-13.18
	σ	0.66	5.03	6.16	4.36	2.49
	V, %	5.78	12.35	18.68	20.46	18.91
February	\bar{X}	-10.09	-39.34	-30.59	-21.28	-12.32
	σ	1.09	3.02	3.61	3.01	1.47
	V, %	10.79	7.67	11.81	14.16	11.97
March	\bar{X}	-7.51	-31.02	-19.28	-13.41	-7.59
	σ	1.01	3.22	3.82	2.59	1.52
	V, %	13.52	10.39	19.80	19.31	20.01
April	\bar{X}	-3.83	-20.84	-1.27	0.47	2.14
	σ	0.67	2.34	2.89	1.99	1.16
	V, %	17.47	11.23	226.94	422.79	54.08
May	\bar{X}	-0.64	-11.28	13.43	11.99	9.76
	σ	0.55	1.65	3.02	2.63	1.65
	V, %	85.37	14.63	22.48	21.93	16.87
June	\bar{X}	2.22	-2.08	25.34	21.14	15.07
	σ	0.41	1.89	2.60	2.14	1.25
	V, %	18.58	90.93	10.27	10.12	8.28
Year	\bar{X}	-3.31	-18.66	-1.47	0.43	1.09
	σ	0.22	1.11	1.20	0.72	0.48
	V, %	6.58	5.95	81.19	167.08	43.50

1 Btu/hr - sq ft = 3.15 w/m²

Table 57 (Cont'd)

Building Identification	4	4	34	34	
Roofing Layer	Figure 6 4A	Figure 7 4B	Figure 8 34A	Figure 9 34B	
Depth in Section (in.)	Total	Total	Total	Total	
July	\bar{X}	18.57	11.38	6.74	9.13
	σ	1.70	1.05	0.69	0.81
	V, %	9.09	9.22	10.23	8.92
August	\bar{X}	17.27	10.36	6.00	8.27
	σ	2.06	1.22	0.89	0.95
	V, %	11.91	11.80	14.89	11.46
September	\bar{X}	10.01	5.48	3.33	4.81
	σ	2.13	1.19	0.88	0.94
	V, %	21.30	21.73	26.34	19.65
October	\bar{X}	2.24	0.85	0.62	1.20
	σ	1.57	0.90	0.39	0.67
	V, %	70.15	105.75	61.96	55.86
November	\bar{X}	-9.31	-5.63	-3.75	-3.99
	σ	1.95	1.09	0.77	0.85
	V, %	20.96	19.43	20.46	21.39
December	\bar{X}	-14.00	-8.24	-5.92	-6.14
	σ	3.29	1.87	0.81	1.44
	V, %	23.50	22.71	13.70	23.47
January	\bar{X}	-18.83	-10.98	-7.75	-8.26
	σ	3.72	2.14	0.58	1.62
	V, %	19.73	19.53	7.56	19.69
February	\bar{X}	-16.93	-9.95	-6.48	-7.33
	σ	2.33	1.34	0.97	1.02
	V, %	13.77	13.42	14.91	13.99
March	\bar{X}	-9.54	-5.76	-4.14	-3.96
	σ	2.45	1.38	0.90	1.08
	V, %	25.67	23.99	21.62	27.20
April	\bar{X}	-0.05	0.37	-0.78	0.40
	σ	1.86	1.05	0.58	0.83
	V, %	3558.60	284.21	74.13	209.76
May	\bar{X}	8.32	5.55	2.12	4.31
	σ	1.82	1.11	0.48	0.88
	V, %	21.89	19.95	22.88	20.53
June	\bar{X}	15.99	9.97	4.66	7.79
	σ	1.67	0.98	0.38	0.77
	V, %	10.48	9.82	8.16	9.95
Year	\bar{X}	0.42	0.34	-0.41	0.56
	σ	0.74	0.42	0.19	0.33
	V, %	175.28	123.69	46.50	58.12

1 Btu/hr - sq ft = 3.15 W/m²

Table 58
Thermal Stains in Composite Roof Systems for Cape Hatteras, NC

Roof System	Roofing Layer	Depth in Section (in)	Temperature			Coefficient of Thermal Expansion (in/in/F)	Thermal Strain (in/in) *
			\bar{X} (F)	σ (F)	V(%)		
5	25 mil Diathon	0.0	71.52	26.47	37.02	4×10^{-5}	6.35×10^{-3}
	Polyurethane Foam	1.0	78.14	4.01	5.13	6×10^{-5}	1.44×10^{-3}
	Gypsum Concrete	3.0	78.51	2.96	3.77	8.5×10^{-6}	1.51×10^{-4}
	Gypsum Plank	4.0	79.22	1.49	1.88	8.5×10^{-6}	7.60×10^{-5}
18	Gacoflex	0.0	67.97	20.82	30.65	7×10^{-5}	8.74×10^{-3}
	Built-up Roofing	0.5	68.97	19.66	28.53	15×10^{-6}	1.77×10^{-3}
	Insulation	1.0	74.45	12.81	17.22	6×10^{-5}	4.61×10^{-3}
	Gypsum Plank	2.5	82.44	2.95	3.58	8.5×10^{-6}	1.50×10^{-4}
2	No. 5 Gravel	0.0	71.39	26.09	36.55	--	--
	Styrofoam Insulation	2.0	70.79	15.80	22.32	6×10^{-5}	5.69×10^{-3}
	Built-up Roofing	3.0	70.37	5.63	8.00	15×10^{-6}	5.07×10^{-4}
	Gypsum Concrete	4.5	70.55	3.56	5.05	8.5×10^{-6}	1.80×10^{-4}
	Gypsum Plank	6.5	71.37	1.26	1.77	8.5×10^{-6}	6.43×10^{-5}

* Thermal Strain at $(\bar{X} \pm 3\sigma)^{\circ}$ F

$$^{\circ}\text{C} = (^{\circ}\text{F} - 32)/1.8$$

Table 58 (Cont'd)

Roof System	Roofing Layer	Depth in Section (in)	Temperature			Coefficient of Thermal Expansion (in/in/F)	Thermal Strain (in/in) *
			\bar{X} (F)	σ (F)	V(%)		
3A	Light Colored Gravel	0.0	71.26	26.06	36.52	--	--
		0.5	71.22	26.00	36.52	--	--
	Built-up Roofing	1.0	71.09	24.88	35.00	15×10^{-6}	2.24×10^{-3}
	Urethane Bound	1.5	71.31	15.30	21.45	6×10^{-5}	5.51×10^{-3}
	Gypsum Plank	3.0	71.73	2.78	3.88	8.5×10^{-6}	1.42×10^{-4}
3B	Light Colored Gravel	0.00	71.40	26.52	37.15	--	--
		0.05	71.35	26.58	37.27	--	--
	Built-up Roofing	1.0	71.15	26.50	37.26	15×10^{-6}	2.38×10^{-3}
	Urethane Board	4.5	71.15	8.55	12.02	6×10^{-5}	3.08×10^{-3}
	Gypsum Plank	7.0	71.83	0.62	0.87	8.5×10^{-6}	3.16×10^{-5}

* Thermal Strain at $(\bar{X} \pm 3\sigma)^{\circ}\text{F}$

$$^{\circ}\text{C} = (^{\circ}\text{F} - 32)/1.8$$

Table 58 (Cont'd)

Roof System	Roofing Layer	Depth in Section (in)	Temperature			Coefficient of Thermal Expansion (in/in/F)	Thermal Strain (in/in) *
			\bar{X} (F)	σ (F)	V(%)		
4A	GAF Mineral Shield	0.0	72.53	24.72	34.10	7.5×10^{-5}	1.11×10^{-2}
		0.5	72.28	23.82	32.97	7.5×10^{-5}	1.07×10^{-2}
	Urethane Board	1.0	72.05	14.73	20.45	6×10^{-5}	5.30×10^{-3}
	Gypsum Plank	2.5	71.89	2.75	3.83	8.5×10^{-6}	1.40×10^{-4}
4B	GAF Mineral Shield	0.0	72.50	25.38	35.03	7.5×10^{-5}	1.14×10^{-2}
		0.5	72.24	25.50	35.32	7.5×10^{-5}	1.14×10^{-2}
	Urethane Board	1.5	71.80	20.86	29.06	6×10^{-5}	7.50×10^{-3}
		4.0	71.60	8.51	11.89	6×10^{-5}	3.06×10^{-3}
Gypsum Plank	6.5	71.89	0.63	0.88	8.5×10^{-6}	3.21×10^{-5}	
34A	EPDM Elastomer	0.0	71.29	27.08	37.99	7.2×10^{-5}	1.17×10^{-2}
	Urethane	1.0	71.18	15.27	21.45	6×10^{-5}	5.50×10^{-3}
	Gypsum Plank	3.0	71.81	1.88	2.62	8.5×10^{-6}	9.59×10^{-5}
34B	EPDM Elastomer	0.0	73.47	25.35	34.52	7.2×10^{-5}	1.10×10^{-2}
	Fiberglass	1.0	72.60	12.97	17.87	6×10^{-5}	4.67×10^{-3}

* Thermal Strain at $(\bar{X} \pm 3\sigma)$ F

$$^{\circ}\text{C} = (^{\circ}\text{F} - 32)/1.8$$

Table 59

Roof System Ranking in Relation to Computed Parameters

Performance Ranking	Freeze-Thaw Cycles	Cooling Rate	Length of Freezing Period	Thermal Strain	Heat Flux
High Performance					
1	2	18	2	3B	34A
2	4A	5	4A	3A	34B
3	3A	4A	3A	2	5
4	4B	34A	4B	5	4B
5	3B	3A	3B	18	3B
6	5	2	5	4A	4A
7	18	4B	18	4B	3A
8	34A	3B	34A	34A	2
9	34B	34B	34B	34B	18

Low Performance

Building Number	Roof System
5	5
18	18
2	2
3	3A,3B
4	4A,4B
34	34A,34B

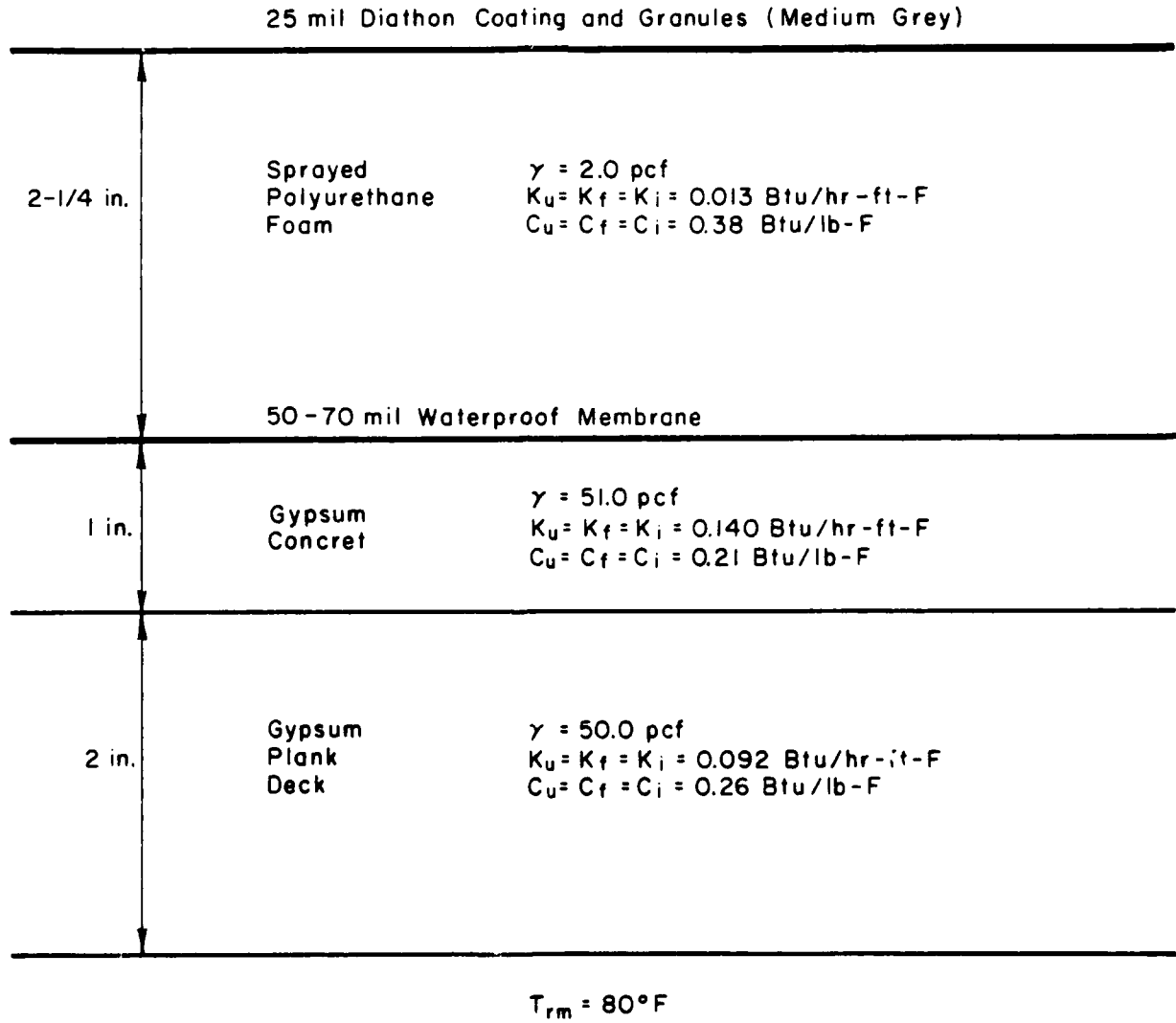
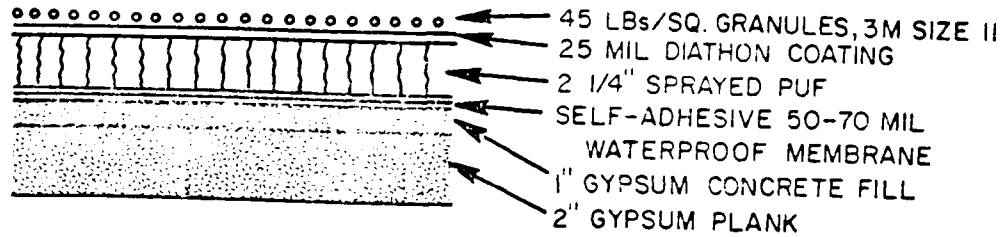
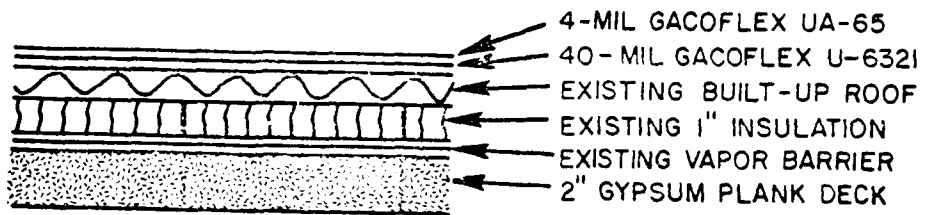

Figure 1. Roof System 5, Building 5, Cape Hatteras, NC.



4 mil Gacoflex UA-65 Over 40 mil Gacoflex U-632I

1/2 in.	Existing Built-Up Roof	$\gamma = 70.0 \text{ pcf}$ $K_u = K_f = K_i = 0.094 \text{ Btu/hr-ft-F}$	$C_u = C_f = C_i = 0.35 \text{ Btu/lb-F}$
1 in.	Insulation	$\gamma = 2.0 \text{ pcf}$ $K_u = K_f = K_i = 0.020 \text{ Btu/hr-ft-F}$ Vapor Barrier	$C_u = C_f = C_i = 0.29 \text{ Btu/lb-F}$
2 in.	Gypsum Plank Deck	$\gamma = 50.0 \text{ pcf}$ $K_u = K_f = K_i = 0.092 \text{ Btu/hr-ft-F}$	$C_u = C_f = C_i = 0.26 \text{ Btu/lb-F}$

$T_{rm} = 85^\circ\text{F}$

Figure 2. Roof System 18, Building 18, Cape Hatteras, NC.

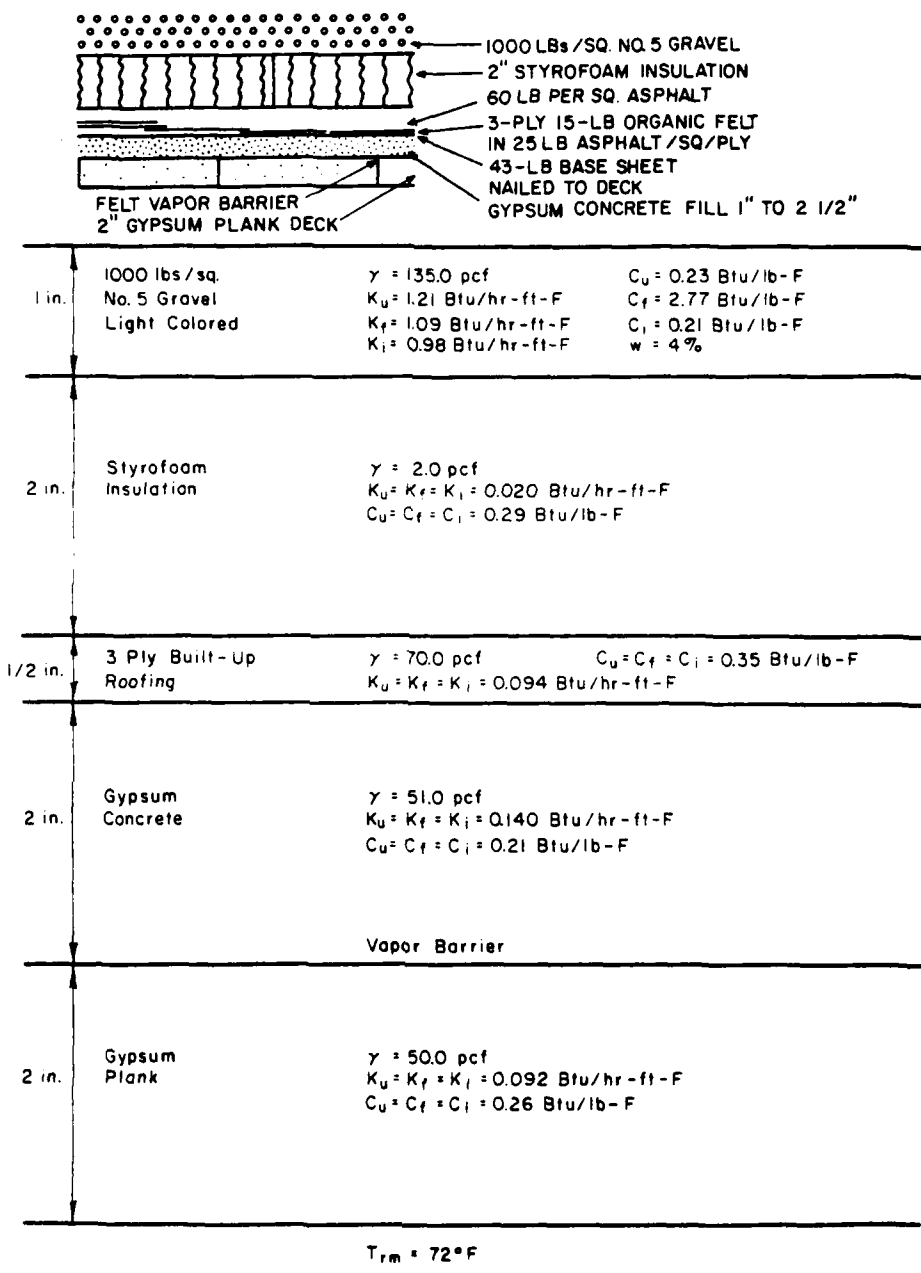
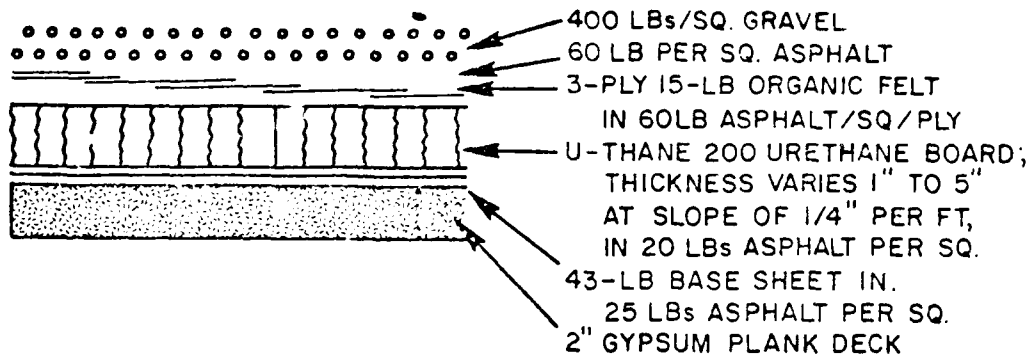

Figure 3. Roof system 2, Building 2, Cape Hatteras, NC.



1/2 in.	400 lb/sq Gravel Light Colored	$\gamma = 135.0$ pcf $K_u = 1.21$ Btu/hr-ft-F $K_f = 1.09$ Btu/hr-ft-F	$K_i = 0.98$ Btu/ft-F $C_u = 0.23$ Btu/lb-F $C_f = 2.77$ Btu/lb-F	$C_i = 0.21$ Btu/lb-F $w = 4\%$
1/2 in.	3 Ply Built-Up Roofing	$\gamma = 70.0$ pcf $K_u = K_f = K_i = 0.094$ Btu/hr-ft-F	$C_u = C_f = C_i = 0.35$ Btu/lb-F	
1 in.	U-Thane 200 Urethane Board	$\gamma = 2.0$ pcf $K_u = K_f = K_i = 0.014$ Btu/hr-ft-F $C_u = C_f = C_i = 0.38$ Btu/lb-F		
1/6 in.	Asphalt and Base Sheet			
2 in.	Gypsum Plank Deck	$\gamma = 50.0$ pcf $K_u = K_f = K_i = 0.092$ Btu/hr-ft-F $C_u = C_f = C_i = 0.26$ Btu/hr-ft-F		

$$T_{rm} = 72^\circ\text{F}$$

Figure 4. Roof System 3A, Building 3, Cape Hatteras, NC.

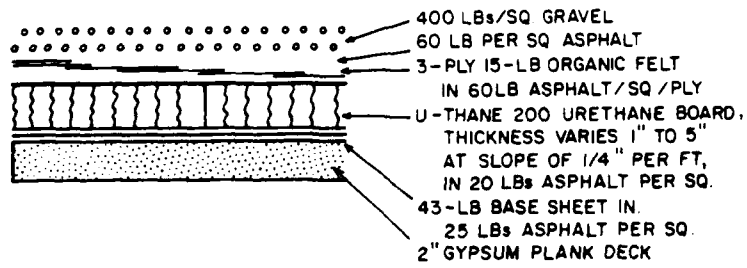

1/2 in.	400 lb/sq Gravel Light Colored	$\gamma = 135.0 \text{ pcf}$ $K_u = 121 \text{ Btu/hr-ft-F}$ $K_f = 109 \text{ Btu/hr-ft-F}$	$K_i = 0.98 \text{ Btu/ft-F}$ $C_u = 0.23 \text{ Btu/lb-F}$ $C_f = 2.77 \text{ Btu/lb-F}$	$C_i = 0.21 \text{ Btu/lb-F}$ $w = 4\%$
1/2 in.	3 Ply Built-Up Roofing	$\gamma = 70.0 \text{ pcf}$ $K_u = K_f = K_i = 0.094 \text{ Btu/hr-ft-F}$	$C_u = C_f = C_i = 0.35 \text{ Btu/lb-F}$	
5 in.	U-Thane 200 Urethane Board	$\gamma = 2.0 \text{ pcf}$ $K_u = K_f = K_i = 0.014 \text{ Btu/hr-ft-F}$ $C_u = C_f = C_i = 0.38 \text{ Btu/lb-F}$		
1/6 in.	Asphalt and Base Sheet			
2 in.	Gypsum Plank Deck	$\gamma = 50.0 \text{ pcf}$ $K_u = K_f = K_i = 0.092 \text{ Btu/hr-ft-F}$ $C_u = C_f = C_i = 0.26 \text{ Btu/hr-ft-F}$		

$T_{rm} = 72^\circ\text{F}$

Figure 5. Roof System 3B, Building 3, Cape Hatteras, NC.

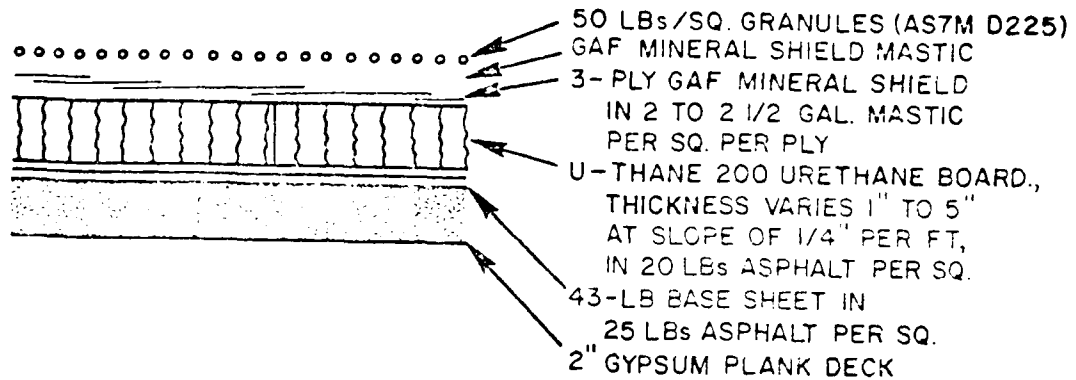

White Granules			
1/2 in.	GAF Mineral Shield Roofing 3 Ply	$\gamma = 70.0 \text{ pcf}$ $K_u = K_f = K_i = 0.094 \text{ Btu/hr-ft-F}$	$C_u = C_f = C_i = 0.35 \text{ Btu/lb-F}$
1 in.	U-Thane 200 Urethane Board	$\gamma = 2.0 \text{ pcf}$ $K_u = K_f = K_i = 0.014 \text{ Btu/hr-ft-F}$ $C_u = C_f = C_i = 0.38 \text{ Btu/lb-F}$	
1/6 in.	Asphalt and Base Sheet		
2 in.	Gypsum Plank Deck	$\gamma = 50.0 \text{ pcf}$ $K_u = K_f = K_i = 0.092 \text{ Btu/hr-ft-F}$ $C_u = C_f = C_i = 0.26 \text{ Btu/lb-F}$	

$T_{rm} = 72^\circ\text{F}$

Figure 6. Roof System 4A, Building 4, Cape Hatteras, NC.

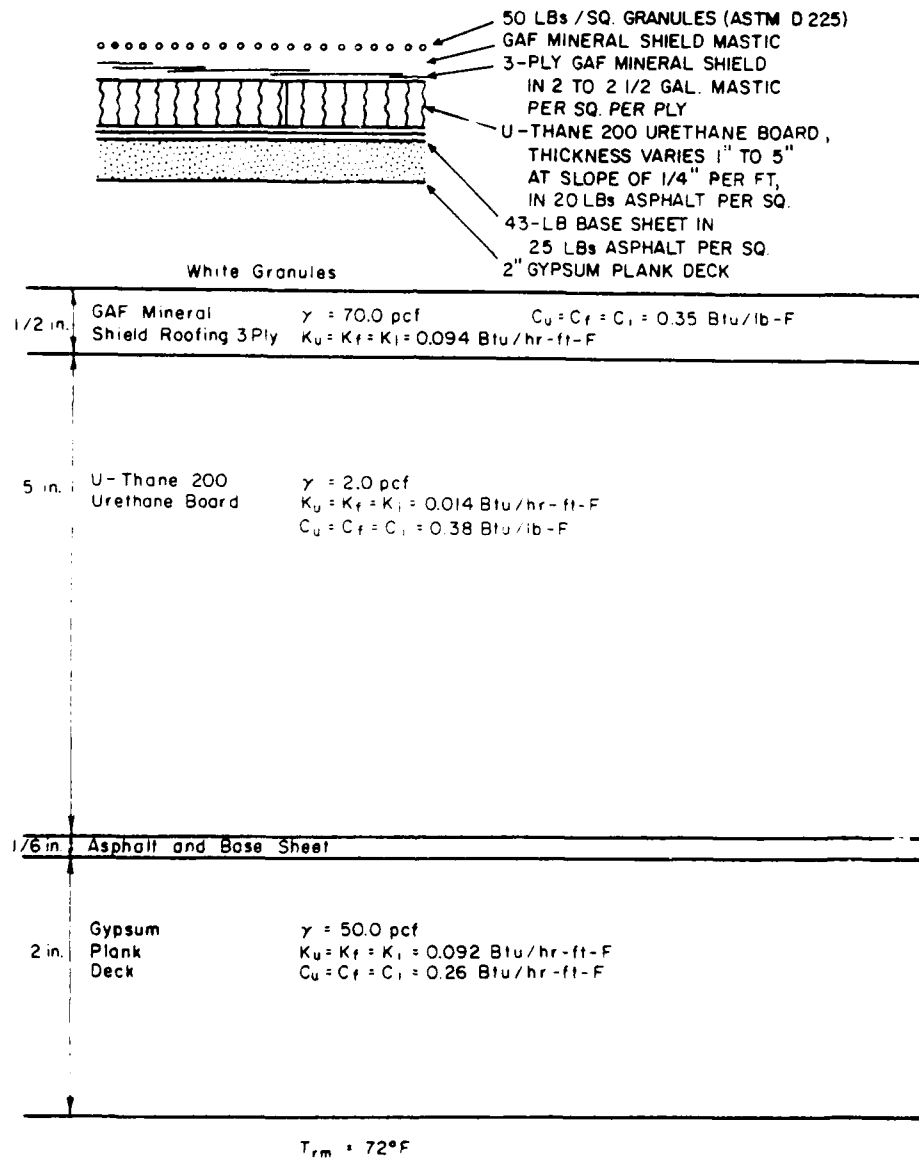

Figure 7. Roof System 4B, Building 4, Cape Hatteras, NC.

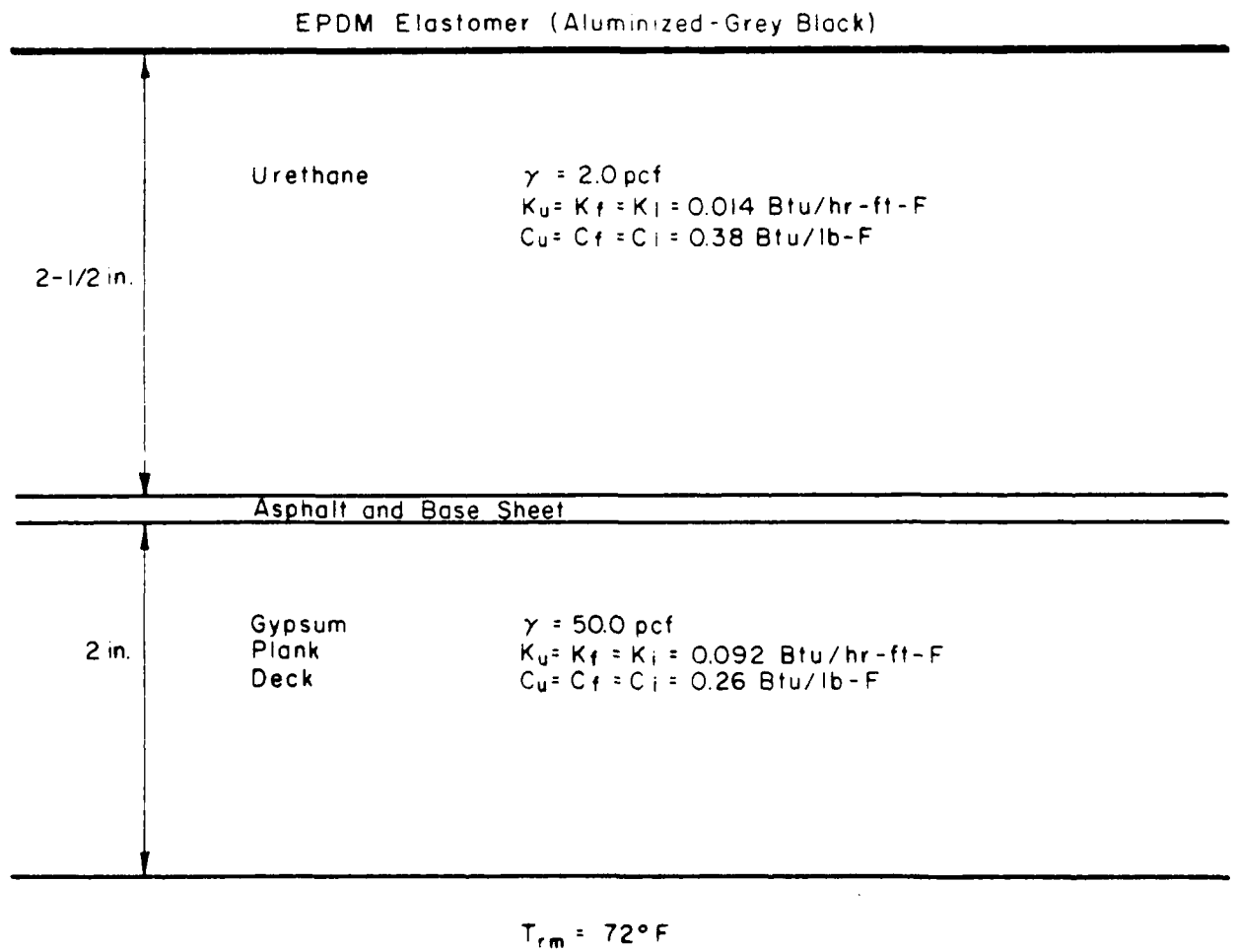
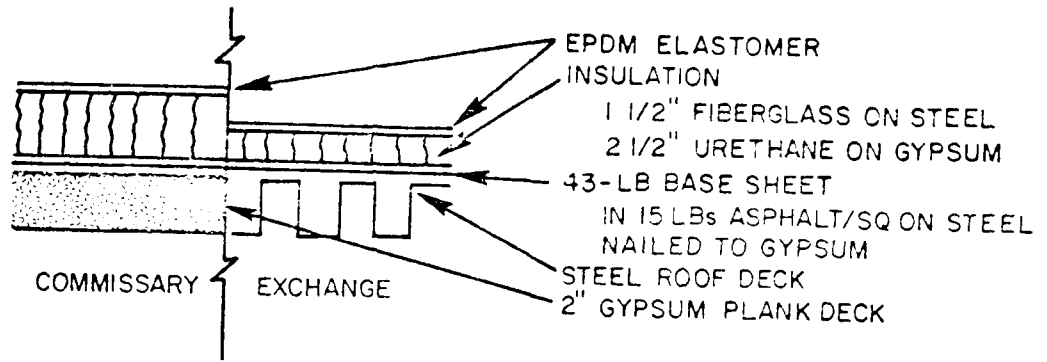
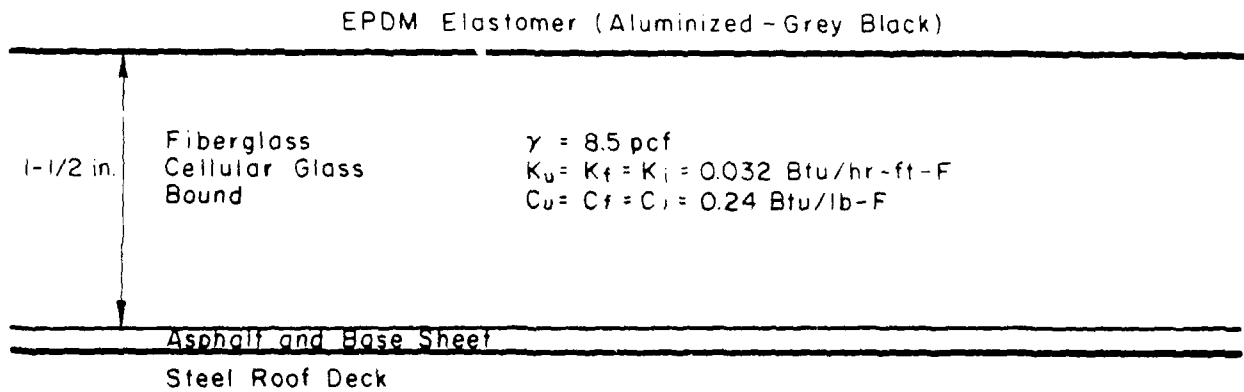
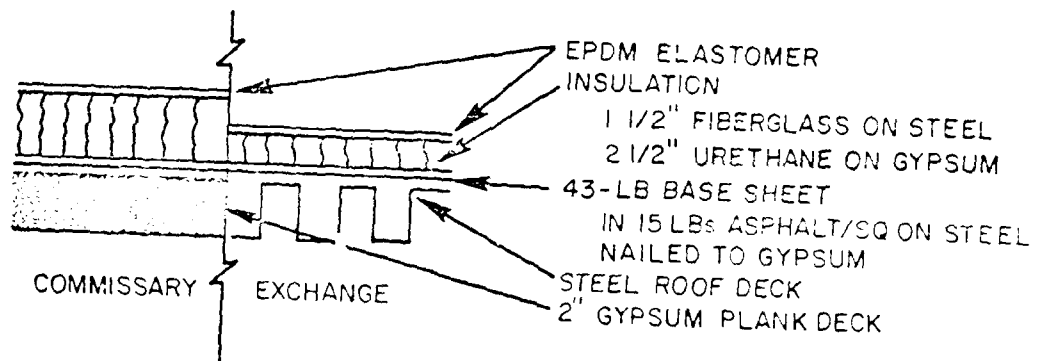

Figure 8. Roof System 34A, Building 34, Cape Hatteras, NC.



$T_{rm} = 72^\circ\text{F}$

Figure 9. Roof System 34B, Building 34, Cape Hatteras, NC.

AD-A090 058

CONSTRUCTION ENGINEERING RESEARCH LAB (ARMY) CHAMPAIGN IL F/G 13/13
A STUDY OF CLIMATIC EFFECTS ON ROOF SYSTEMS AT CAPE HATTERAS, N--ETC(U)
MAR 81 B J DEMPSEY

UNCLASSIFIED

CERL-TR-M-285

NL

2 of 2

Page 2



END

DATE

FORMED

5-81

DTIC

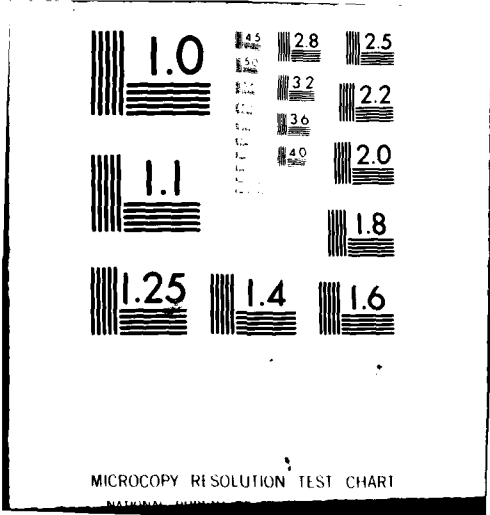

MICROCOPY RESOLUTION TEST CHART

NATIONAL BUREAU OF STANDARDS-1963-A

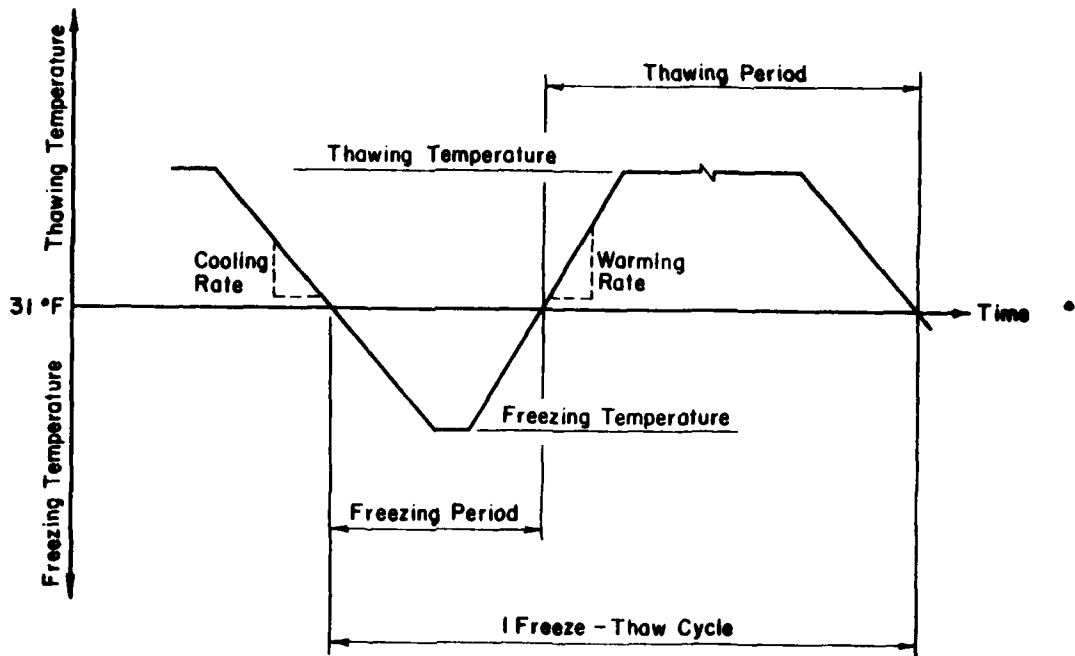

Figure 10. Idealized freeze-thaw cycle for a roof system.

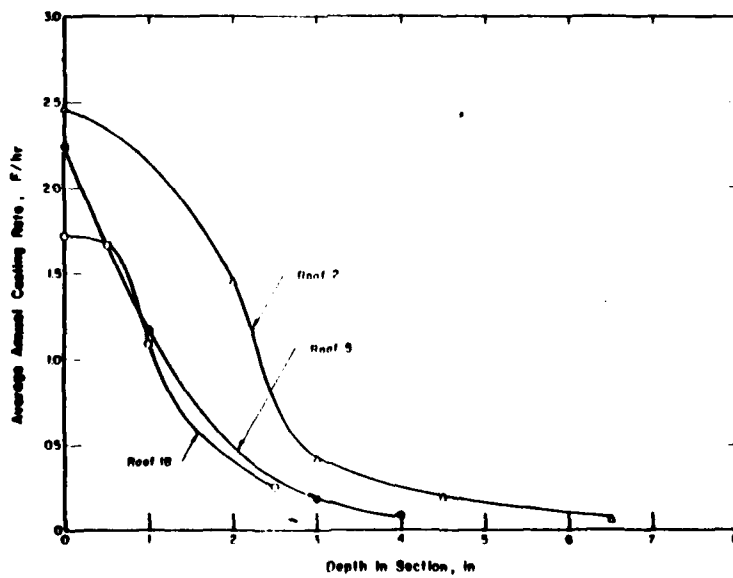

Figure 11. Average cooling rates for roof systems on Buildings 5, 18, and 2.

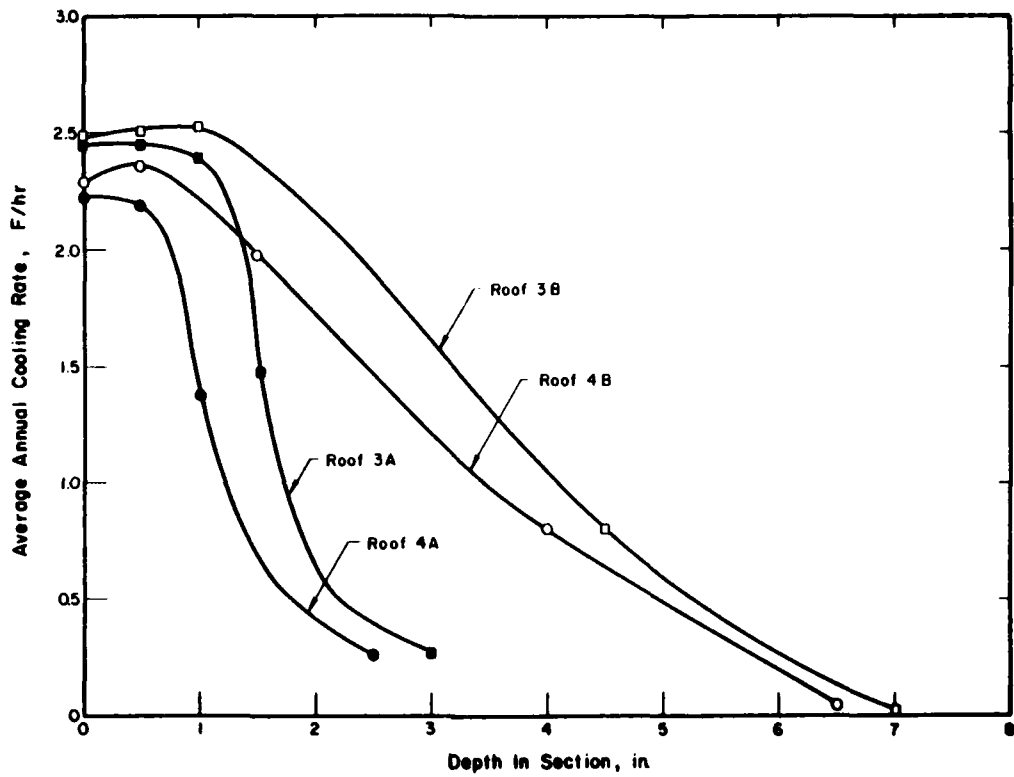

Figure 12. Average cooling rates for roof systems on Buildings 3 and 4.

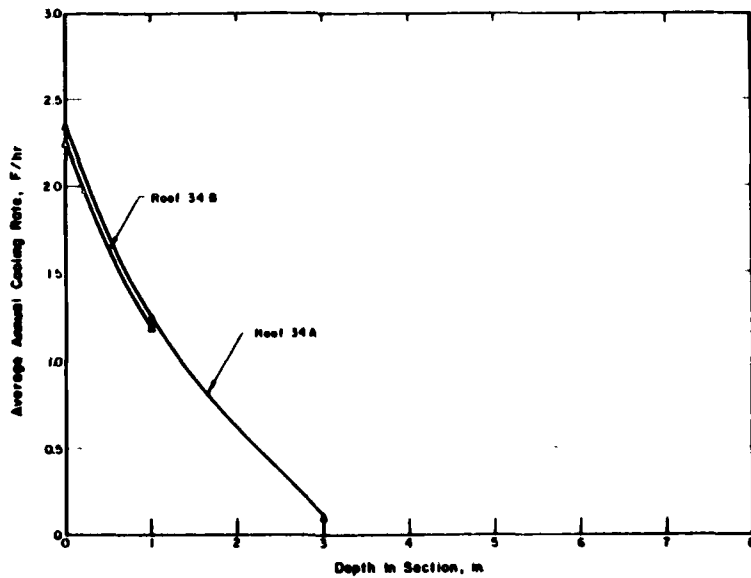

Figure 13. Average cooling rates for roof systems on Building 34.

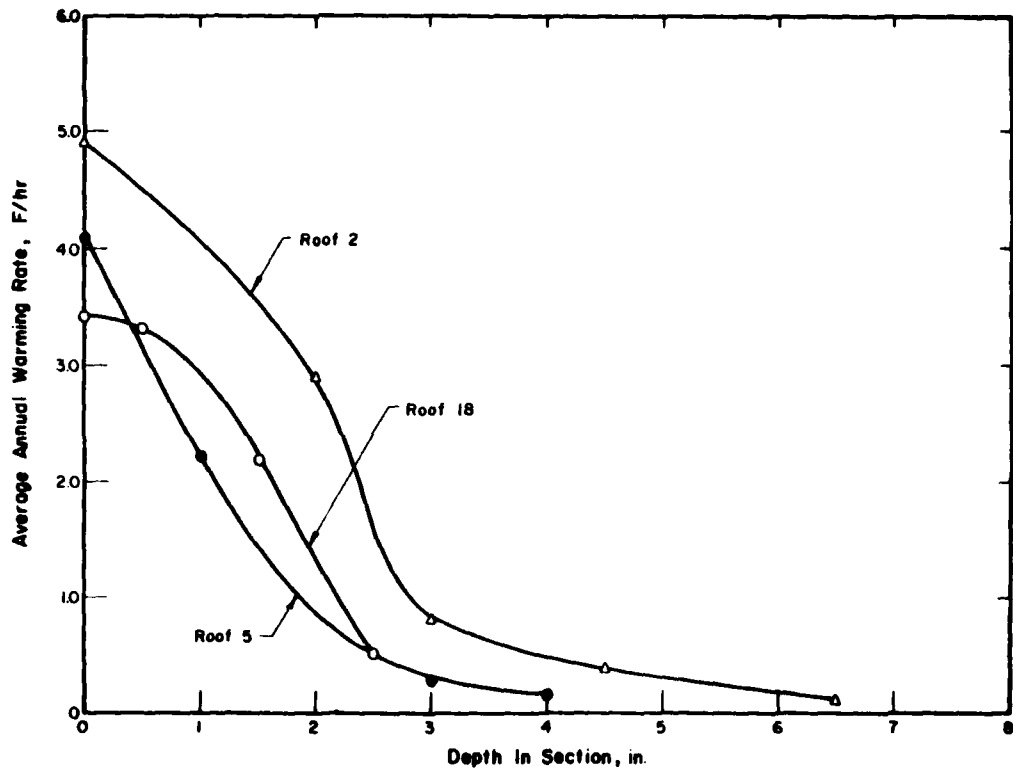

Figure 14. Average warming rates for roof systems on Buildings 5, 18, and 2.

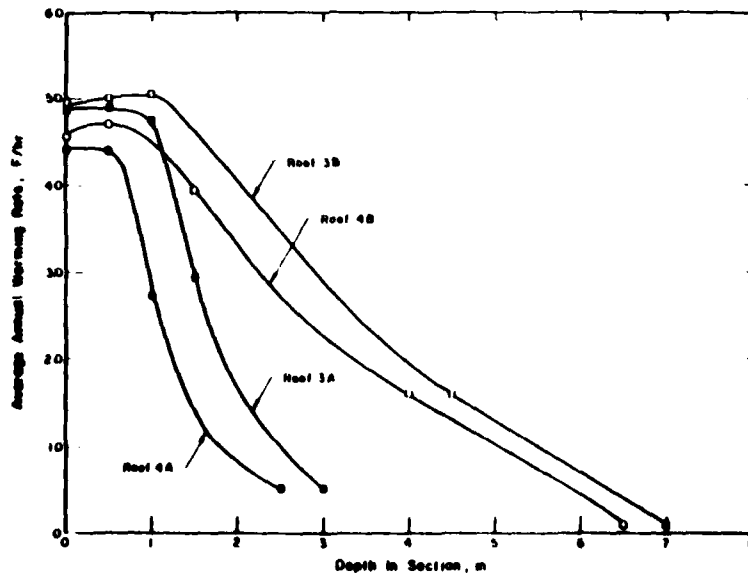

Figure 15. Average warming rates for roof systems on Buildings 3 and 4.

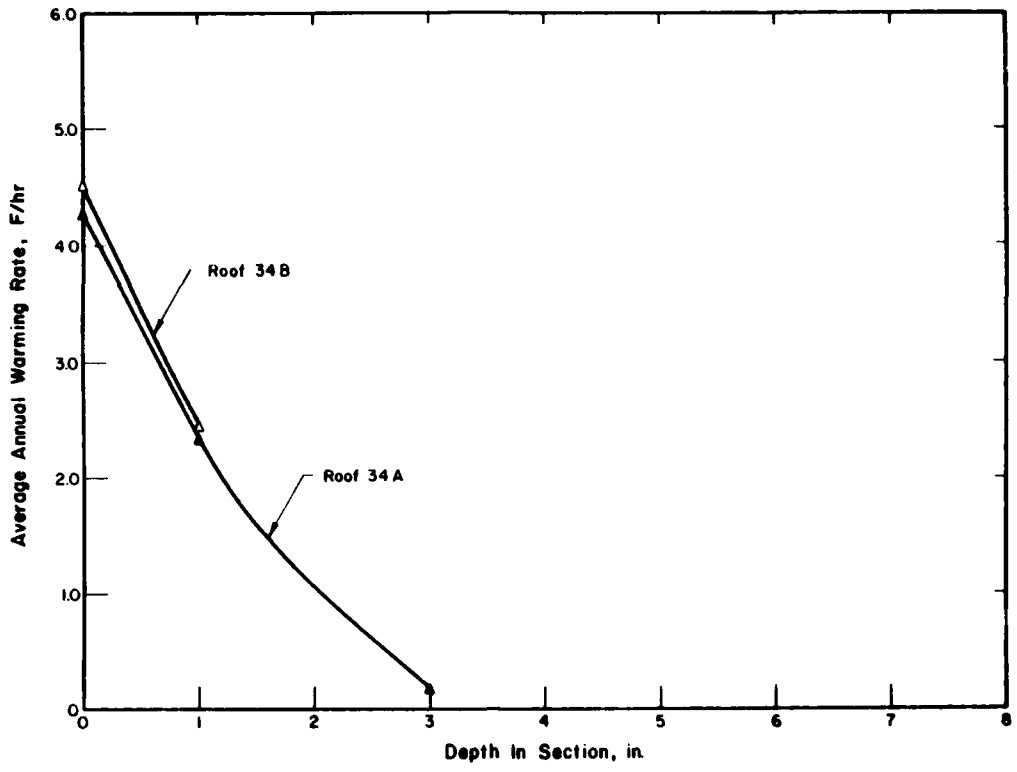

Figure 16. Average warming rates for roof systems on Building 34.

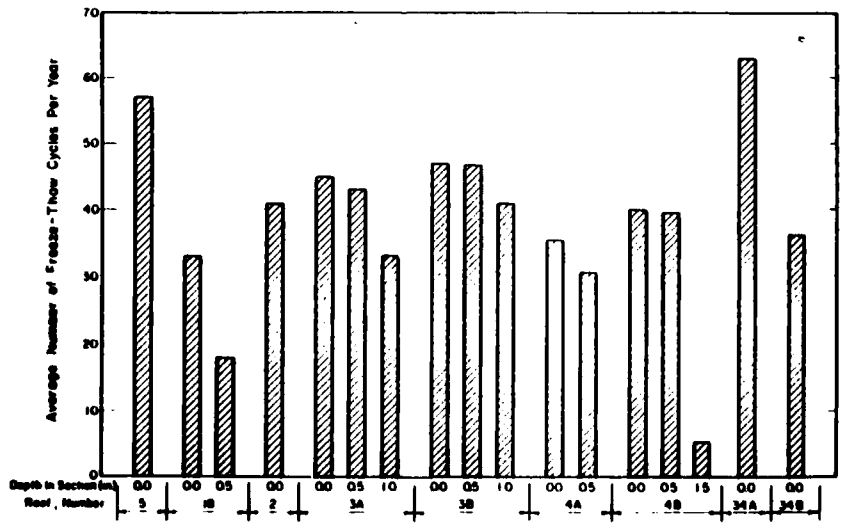

Figure 17. Average number of freeze-thaw cycles per year.

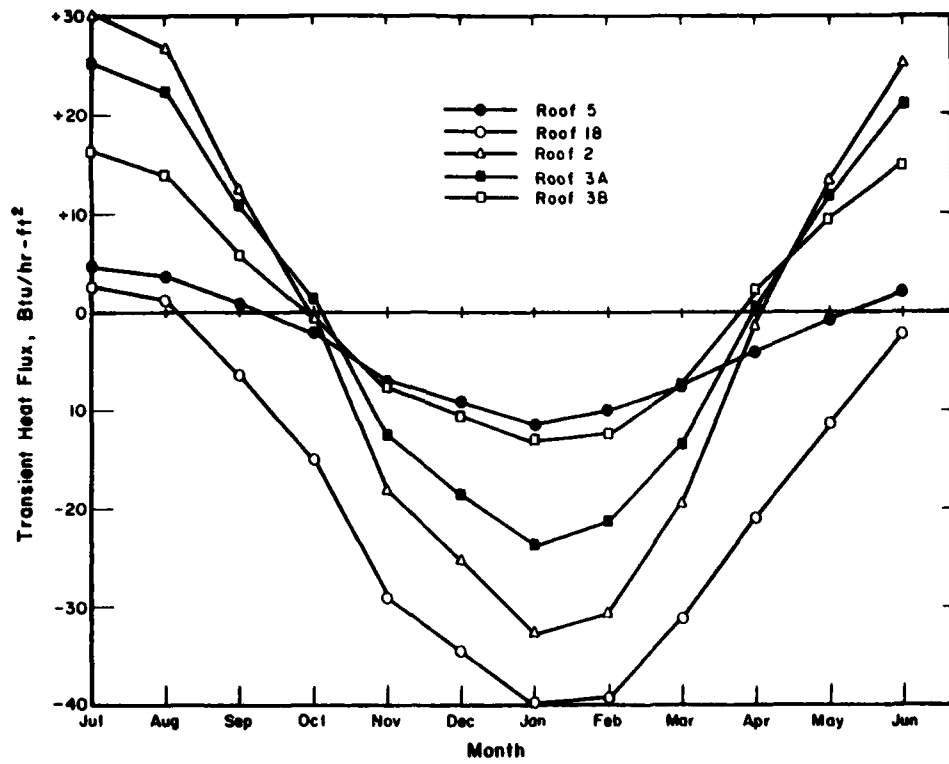

Figure 18. Transient heat flux for Building 5, 18, 2, and 3.

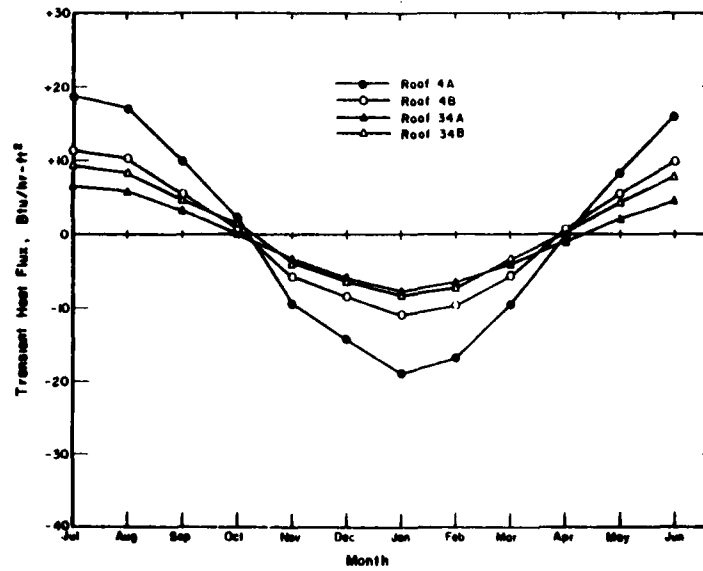

Figure 19. Transient heat flux for Buildings 4 and 34.

List of Abbreviations

BUR	Built-up roofing	
C_f	Mass heat capacity of freezing material	Btu/lb ^{°F}
C_i	Mass heat capacity of a frozen material	Btu/lb- ^{°F}
C_u	Mass heat capacity of an unfrozen material	Btu/lb- _u ^{°F}
EPDM	Ethylene Propylene Diene Monomer	
k	General thermal conductivity designation	Btu in./hr-ft ² - ^{°F}
K	General thermal conductivity designation 12 in./ft	Btu/hr-ft- ^{°F}
K_f	Thermal conductivity of a freezing material	Btu/hr-ft- ^{°F}
K_i	Thermal conductivity of a frozen material	Btu/hr-ft- ^{°F}
K_u	Thermal conductivity of an unfrozen material	Btu/hr-ft- ^{°F}
PMR	Protected Membrane Roof	
T_{rm}	Interior building temperature	^{°F}
V	Coefficient of variation	percent
w	Water content based on dry weight	percent
\bar{X}	Statistical mean	
γ	Total unit weight	pcf
σ	Standard deviation	

CERL DISTRIBUTION

Chief of Engineers
 ATTN: Tech Monitor
 ATTN: DAEN-ASI-L (2)
 ATTN: DAEN-CCP
 ATTN: DAEN-CN
 ATTN: DAEN-CME
 ATTN: DAEN-CMM-R
 ATTN: DAEN-CMO
 ATTN: DAEN-CMP
 ATTN: DAEN-MP
 ATTN: DAEN-MPC
 ATTN: DAEN-MPE
 ATTN: DAEN-MPO
 ATTN: DAEN-MPR-A
 ATTN: DAEN-RD
 ATTN: DAEN-RDC
 ATTN: DAEN-RDM
 ATTN: DAEN-RM
 ATTN: DAEN-ZC
 ATTN: DAEN-ZCE
 ATTN: DAEN-ZCI
 ATTN: DAEN-ZCM

US Army Engineer Districts

ATTN: Library

Alaska
 Al Batin
 Albuquerque
 Baltimore
 Buffalo
 Charleston
 Chicago
 Detroit
 Far East
 Fort Worth
 Galveston
 Huntington
 Jacksonville
 Japan
 Kansas City
 Little Rock
 Los Angeles
 Louisville
 Memphis
 Mobile
 Nashville
 New Orleans
 New York
 Norfolk
 Omaha
 Philadelphia
 Pittsburgh
 Portland
 Riyadh
 Rock Island
 Sacramento
 San Francisco
 Savannah
 Seattle
 St. Louis
 St. Paul
 Tulsa
 Vicksburg
 Walla Walla
 Wilmington

US Army Engineer Divisions

ATTN: Library

Europe
 Huntsville
 Lower Mississippi Valley
 Middle East
 Middle East (Rear)
 Missouri River
 New England
 North Atlantic
 North Central
 North Pacific
 Ohio River
 Pacific Ocean
 South Atlantic
 South Pacific
 Southwestern

Waterways Experiment Station

ATTN: Library

Cold Regions Research Engineering Lab

ATTN: Library

US Government Printing Office

Receiving Section/Depository Copies (2)

Defense Technical Information Center

ATTN: DDA (12)

Engineering Societies Library
 New York, NY

FESA, ATTN: Library

ETL, ATTN: Library

Engr. Studies Center, ATTN: Library

Inst. for Water Res., ATTN: Library

Army Instl. and Major Activities (CONUS)

DARCOM - Dir., Inst., & Svcs.

ATTN: Facilities Engineer

ARRADCOM

Aberdeen Proving Ground

Army Matls. and Mechanics Res. Ctr.

Corpus Christi Army Depot

Harry Diamond Laboratories

Dugway Proving Ground

Jefferson Proving Ground

Fort Monmouth

Letterkenny Army Depot

Natick Research and Dev. Ctr.

New Cumberland Army Depot

Pueblo Army Depot

Red River Army Depot

Redstone Arsenal

Rock Island Arsenal

Savanna Army Depot

Sharpe Army Depot

Seneca Army Depot

Tobyhanna Army Depot

Tooele Army Depot

Watervliet Arsenal

Yuma Proving Ground

White Sands Missile Range

FORSCOM

FORSCOM Engineer, ATTN: AFEN-FE

ATTN: Facilities Engineers

Fort Buchanan

Fort Bragg

Fort Campbell

Fort Carson

Fort Devens

Fort Drum

Fort Hood

Fort Indiantown Gap

Fort Irwin

Fort Sam Houston

Fort Lewis

Fort McCoy

Fort McPherson

Fort George G. Meade

Fort Ord

Fort Polk

Fort Richardson

Fort Riley

Presidio of San Francisco

Fort Sheridan

Fort Stewart

Fort Walworth

Vancouver Bks.

TRADOC

HQ, TRADOC, ATTN: ATEN-FE

ATTN: Facilities Engineer

Fort Belvoir

Fort Benning

Fort Bliss

Carlisle Barracks

Fort Chaffee

Fort Dix

Fort Eustis

Fort Gordon

Fort Hamilton

Fort Benjamin Harrison

Fort Jackson

Fort Knox

Fort Leavenworth

Fort Lee

Fort McClellan

Fort Monroe

Fort Rucker

Fort Sill

Fort Leonard Wood

INSCOM - Ch, Instl. Div.

ATTN: Facilities Engineer

Vint Hill Farms Station

Arlington Hall Station

WESTCOM

ATTN: Facilities Engineer

Fort Shafter

MDW

ATTN: Facilities Engineer

Cameron Station

Fort Lesley J. McNair

Fort Myer

MSC

HQ USAHSC, ATTN: MSLO-F

ATTN: Facilities Engineer

Fitzsimons Army Medical Center

Walter Reed Army Medical Center

USACC

ATTN: Facilities Engineer

Fort Huachuca

Fort Ritchie

HTMC

HQ, ATTN: HTMC-SA

ATTN: Facilities Engineer

Oakland Army Base

Bayonne MDJ

Sunny Point MDJ

US Military Academy

ATTN: Facilities Engineer

ATTN: Dept of Geography &

Computer Science

USAES, Fort Belvoir, VA

ATTN: ATZA-DTE-EM

ATTN: ATZA-DTE-SU

ATTN: Engr. Library

Chief Inst. Div., IBSA, Rock Island.

USA ARRCOM, ATTN: Dir., Instl & Svc

TARCOM, Fac. Div.

TECOM, ATTN: DRSTE-LG-F

TSARCOM, ATTN: STSAS-F

NARAD COM, ATTN: DRONA-F

AMARC, ATTN: DRADR-WE

HQ, XVIII Airborne Corps and

Ft. Bragg

ATTN: AFZA-FE-EE

HQ, 7th Army Training Command

ATTN: AETTG-DEH (5)

HQ USAREUR and 7th Army

ODCS/Engineer

ATTN: AEAEN-EH (4)

V Corps

ATTN: AETVDEH (5)

VII Corps

ATTN: AETSDEH (5)

21st Support Command

ATTN: AEREH (5)

US Army Berlin

ATTN: AEBE-EN (2)

US Army Southern European Task Force

ATTN: AESE-ENG (5)

US Army Installation Support Activity

Europe

ATTN: AEUES-RP

8th USA, Korea

ATTN: EAFE

Cdr, Fac Engr Act (8)

AFE, Yongsan Area

AFE, 2d Inf Div

AFE, Area 77 Spt Det

AFE, Cp Humphreys

AFE, Pusan

AFE, Taegu

DLA ATTN: DLA-WI

USA Japan (USARJ)

Ch, FE Div, AJEN-FE

Fac Engr (Monshu)

Fac Engr (Okinawa)

ROK/US Combined Forces Command

ATTN: EUSA-HMC-CFC/Engr

416th Engineer Command

ATTN: Facilities Engineering

Norton AFB

ATTN: AFRC-EN/DEE

Dempsey, Barry J

A study of climatic effects on roof systems at Cape Hatteras, North Carolina. -- Champaign, IL ; Construction Engineering Research Laboratory ; Springfield, VA ; available from NTIS, 1981.

101 p. (Technical report ; M-285)

1. Cape Hatteras, NC. 2. Roofs -- climatic factors.
I. Title. II. Series: U.S. Army. Construction Engineering Research Laboratory. Technical report ; M-285. III. Title: Climatic effects on roof systems at Cape Hatteras, NC.

DA
FILM