

AD-A098 498 AIR FORCE WRIGHT AERONAUTICAL LABS WRIGHT-PATTERSON AFB OH F/G 17/2.1
SCINTILLATION FADING SIMULATION.(U)

MAR 81 W T HUNT

AFWAL-TR-80-1187

NL

UNCLASSIFIED

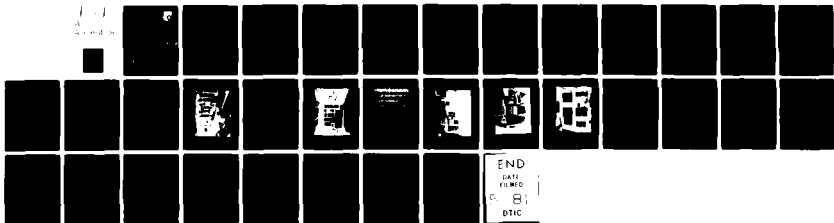

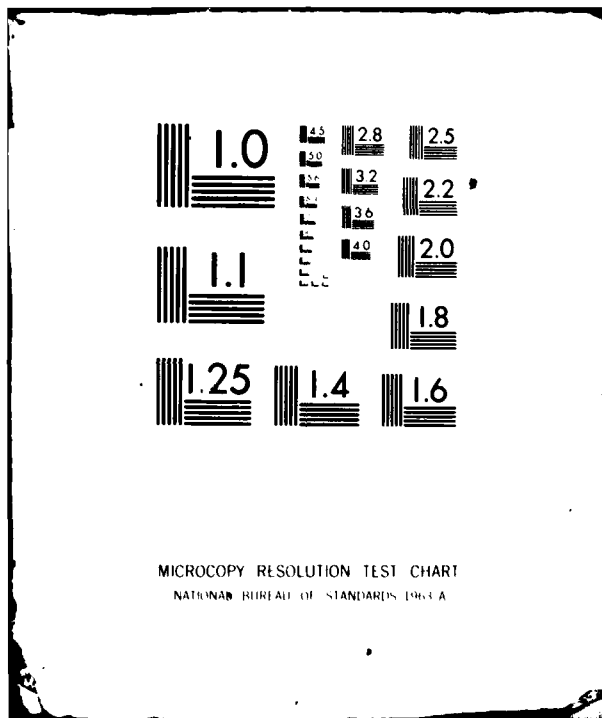

AFWAL-TR-80-1187



fu

AD A 098 498

SCINTILLATION FADING SIMULATION

Wade T. Hunt

Information Transmission Branch
Systems Avionics Division

March 1981

TECHNICAL REPORT AFWAL-TR-80-1187

Final Report for Period November 1977 to December 1979

DTIC
ELECTE
MAY 7 1981
S D A

Approved for public release; distribution unlimited.

DTIC FILE COPY

AVIONICS LABORATORY
AIR FORCE WRIGHT AERONAUTICAL LABORATORIES
AIR FORCE SYSTEMS COMMAND
WRIGHT-PATTERSON AIR FORCE BASE, OHIO 45433

81 5 06 129

NOTICE

When Government drawings, specifications, or other data are used for any purpose other than in connection with a definitely related Government procurement operation, the United States Government thereby incurs no responsibility nor any obligation whatsoever; and the fact that the government may have formulated, furnished, or in any way supplied the said drawings, specifications, or other data, is not to be regarded by implication or otherwise as in any manner licensing the holder or any other person or corporation, or conveying any rights or permission to manufacture use, or sell any patented invention that may in any way be related thereto.

This report has been reviewed by the Office of Public Affairs (ASD/PA) and is releasable to the National Technical Information Service (NTIS). At NTIS, it will be available to the general public, including foreign nations.

This technical report has been reviewed and is approved for publication.

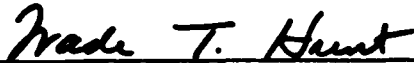

WADE T. HUNT
Project Engineer
Information Transmission Br.



CHARLES C. GAUDER
Chief, Information Transmission Br.

FOR THE COMMANDER

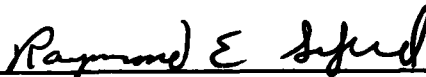

RAYMOND E. SIFERD, Colonel, USAF
Chief, System Avionics Division

"If your address has changed, if you wish to be removed from our mailing list, or if the addressee is no longer employed by your organization please notify AFWAL/AAAD, W-PAFB, OH 45433 to help us maintain a current mailing list".

Copies of this report should not be returned unless return is required by security considerations, contractual obligations, or notice on a specific document.

REPORT DOCUMENTATION PAGE		READ INSTRUCTIONS BEFORE COMPLETING FORM	
1. REPORT NUMBER AFNAL-TR-88-1187 ✓	2. GOVT ACCESSION NO. AD-A098 498	3. RECIPIENT'S CATALOG NUMBER	
4. TITLE (and Subtitle) SCINTILLATION FADING SIMULATION		5. TYPE OF REPORT & PERIOD COVERED Final Report November 77 to December 79	
6. AUTHOR(s) Wade T. Hunt		7. PERFORMING ORG. REPORT NUMBER	
8. CONTRACT OR GRANT NUMBER(s)		9. PROGRAM ELEMENT, PROJECT, TASK AREA & WORK UNIT NUMBERS Project No. 1227 Task No. 122703 Work Unit No. 12270324	
9. PERFORMING ORGANIZATION NAME AND ADDRESS Avionics Laboratory (AFNAL/AAAD) Air Force Wright Aeronautical Laboratories (AFSC) Wright-Patterson Air Force Base, Ohio 45433		10. REPORT DATE March 1981	
11. CONTROLLING OFFICE NAME AND ADDRESS Avionics Laboratory (AFNAL/AAA) Air Force Wright Aeronautical Laboratories (AFSC) Wright-Patterson Air Force Base, Ohio 45433		11. NUMBER OF PAGES 38	
12. MONITORING AGENCY NAME & ADDRESS (if different from Controlling Office) 12 33		12. SECURITY CLASS. (of this report) Unclassified	
13. DISTRIBUTION STATEMENT (of this Report) Approved for public release; distribution unlimited.		13a. DECLASSIFICATION/DOWNGRADING SCHEDULE	
14. DISTRIBUTION STATEMENT (of the abstract entered in Block 20, if different from Report)			
15. SUPPLEMENTARY NOTES			
16. KEY WORDS (Continue on reverse side if necessary and identify by block number) Scintillation Fading Simulation Ionospheric Scintillation Satellite Communication			
17. ABSTRACT (Continue on reverse side if necessary and identify by block number) It is difficult to determine the long term effects of ionospheric scintillation on a particular modulation/coding scheme since the scintillation characteristics change rapidly. In order to measure the effect of the scintillation fading on the acquisition time, it would be necessary to repeat the acquisition test several hundred times. Since the acquisition of a modem such as the Dual UHF modem may take 1 to 5 minutes, it would be necessary to have scintillation fading for a period of 4 to 8 hours.			

392.662

AB

SECURITY CLASSIFICATION OF THIS PAGE(When Data Entered)

The alternative is to record the UHF signal level of a simulator and reproduce a short segment of fading over and over again. This was done using the Avionics Laboratory Communication Systems Evaluation Laboratory (CSEL).

SECURITY CLASSIFICATION OF THIS PAGE(When Data Entered)

FOREWORD

This report was prepared by Mr. Wade T. Hunt (AFWAL/AAAD) of the System Avionics Division of the Avionics Laboratory, under Project 1227, "Communication Systems Concepts and Technology." The work was done to demonstrate the value of being able to simulate satellite communication links in a controlled laboratory environment such as CSEL. The simulation can be repeated many times which cannot be done in flight testing in a cost effective manner.

The help and suggestions by Mr. Allen L. Johnson in writing and organizing the text is greatly appreciated. Also, the help of Mr. Arnold Feineman, Mr. William Jardine, Mr. Steve Thompson and Ms. Susan Pfaad, all formerly with Systems Research Laboratory (SRL), and Mr. James T. Zurn (TRW) in making the measurements is greatly appreciated.

SRL has a contract for service and maintenance of the CSEL facility and TRW has a service contract for service and maintenance of the modem.

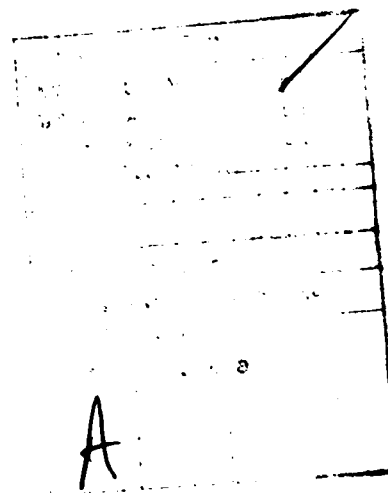

AFWAL-TR-80-1187

TABLE OF CONTENTS

SECTION		PAGE
I	INTRODUCTION	1
II	TEST PROCEDURES	2
III	TEST RESULTS	6
IV	SUMMARY AND CONCLUSIONS	7
	REFERENCES	8

LIST OF ILLUSTRATIONS

FIGURE		PAGE
1	Picture of CSEL	9
2	Forward Link Scintillation Fading Simulation	10
3	Spectrum and Interference Generator	11
4	Samples of Rapid, Medium, and Very Slow Scintillation Fading	12
5	Rooftop Facility	13
6	UHF Modem	14
7	Programmable Signal Processor	15
8	Error Free TTY Message Copy	16
9	Message Containing Errors	17
10	Simulation Without Fade	18
11	Ionospheric Scintillation Fading from LES 9	19
12	10 Minute Sample of Medium Fade Data	20
13	Simulation with Fading	21
14	Forward Link Percent Message Copy	22
15	Baseline Acquisition Test Results	23
16	UHF Modem Acquisition Time in Seconds Vs. No. of Occurrences	24
17	UHF Modem Acquisition Time Frequency Distributions	25
18	Acquisition Time Statistics Without Fade	26
19	Acquisition Time Statistics with Fade	27

SECTION I
INTRODUCTION

Amplitude fluctuations believed to be caused by variations in ionospheric structure are termed scintillation fading. It is dependent on radio frequency, geographic position, and geomagnetic conditions.

Since scintillation fading characteristics change rapidly, it is very difficult to determine the long term effects of ionospheric scintillation fading on a particular modulation/coding scheme. In order to measure the effects of scintillation fading on bit-error-rate or acquisition time it is necessary to have a consistent type of scintillation fading pattern for a long enough period of time to get an adequate data sample.

Because the acquisition time of modems may take from one to five minutes, it would be necessary to have scintillation fading characteristics to remain constant for a period of four to eight hours in order that a good sample might be obtained.

The alternative is to record the UHF signal level of the scintillation fading and use the recording to vary the signal level of a signal simulator. This would allow reproduction of short, consistent segments of fading over and over again in order to get sufficient sample size.

SECTION II
TEST PROCEDURE

The Avionics Laboratory Communication Systems Evaluation Laboratory (CSEL) is equipped with a Lincoln Experimental Satellite number 8 & 9 (LES 8/9) satellite simulator, Figure 1, which can generate a UHF downlink signal with the LES 8/9 modulation. The downlink signal is a 660 bit encoded message at 150 bps data rate. The MD 1004 UHF modem decodes the message and outputs a 40 character, 75 bps teletype message (Reference 1). A drawing of the test setup for the scintillation fading simulator is shown in Figure 2.

For the forward link simulation the concept is to generate a forward link message in the LES 8/9 simulator and then attenuate the output using a digitally controlled pin diode attenuator driven by a reproduction of the UHF scintillation fade signal level. The 660 bit encoded/interleaved forward link message is repetitively sent from the LES 8/9 simulator to a Spectrum and Interference Generator (SIG) (Figure 3). In the SIG, the signal is down-converted to 560 MHz and attenuated with a pin diode attenuator. The scintillation information is originally recorded on a 14 channel analogue magnetic tape recorded during a flight test typically to the polar or equatorial region. Ten minute samples of the data are selected in order to give a representation of rapid, medium, or very slow scintillation fading as shown in Figure 4 (Reference 2). The data is transcribed from the tape recorder and stored on a disk pack and fed into a PDP-11 computer. The PDP-11 computer derives the necessary output voltage to operate the pin diode attenuator and reproduce the scintillation fading. After the pin diode attenuator, the signal is mixed down to the UHF frequency and output. The output signal is fed into the Rooftop Facility (Figure 5), and then through a manual attenuator to adjust the absolute signal level. Then the signal is fed to a UHF transceiver in the Rooftop Facility. The UHF transceiver dehops the frequency hopped signal and down converts it to a 70 MHz IF where it is fed to the UHF modem (Figure 6). The modem completes the dehops procedure, deinterleaves,

decodes, and prints out the teletype message. The 40 character teletype message used in the simulation is "SCINTILLATION FADING SIMULATION AFAL AAD". The decoder generates a link quality indication which identifies the number of channel errors corrected by the decoder. The link quality is a measure of the channel error rate prior to decoding. The link quality is available visibly on a LED display and can be recorded on magnetic tape for later analysis.

The Programmable Signal Processor (PSP), Figure 7, which is used to simulate the LES 8/9 satellite configuration, was set to generate a 700 MHZ IF signal that is converted to 560 MHZ with the frequency converter in the Spectrum and Interference Generator (SIG). The 560 MHZ signal is converted to L Band in the SIG and then converted to the UHF frequency of 242 MHZ in the signal combiner. The output (242 MHZ) from the signal combiner is sent to the Rooftop by coaxial cable where the signal is attenuated to a level of -120 dBm for reference. The UHF signal is converted to 70 MHZ by the radio and fed into the single modem. At a level of -120 dBm, signals from the single modem are received error free. Figure 8 is a sample of an error free copy of the received message. The signal was then reduced in 3dB steps and the link quality was recorded at each 3dB step until the modem lost lock. Figure 9 is a sample copy of a message containing errors. A curve for simulation under nonfading conditions is shown in Figure 10.

Fading was then added to the signal using a 10 minute sample of scintillation fading signals (taken during the 17 March 1977 flight test), Figure 11, which drives a digitally variable attenuator to cause the output UHF signal to vary in accordance with scintillation fading rate and depth. When set up for the fading condition, the signal level into the single modem was set at a -107 dBm level.

The fading data used is a 10 minute sample of medium rate fading (periods of 2 to 5 seconds). The data (amplitude variations) was digitized by the 4950th Test Wing data reduction facility on a 7-track

digital tape at a sample rate of 20 samples per second. The tape is then converted to a 9-track digital tape which is compatible with the CSEL tape playback equipment. The 9-track tape is used to load the disk memory in CSEL. The fade duration used in the simulation lasts for approximately 10 minutes. The disk information is used by the PDP 11/50 computer to generate the analog voltages to drive the pin diode variable attenuator in CSEL in one dB steps. This 10 minute sample of data is shown in Figure 12.

The link quality is measured for a -107 dBm signal level after which the signal level to the modem is reduced in 3dB steps and measurements are made until the power is reduced to a level where the single modem cannot maintain lock. Figure 13 is a curve of simulation with fading added to the signal (Reference 3). The link quality numbers on the graphs of Figures 10 and 13 are generated by counting the information bit and parity bit errors. This count is used as a "quality" indicator for the communication link. A count of 00 indicates no errors and a large number indicates many errors. The maximum number that can be displayed is 77 octal which equals 63 decimal.

Due to the steepness of the Bit Error Rate (BER) curve as the signal level is decreased (attenuation increased), the link quality curve changes from a convex shape to a concave shape as the BER threshold is reached (around 37 dB attenuation on Figure 10 and around 30 dB attenuation on Figure 13).

Figure 4 is a plot of the Forward Link percent Message Copy for both fading and non-fading conditions (Reference 3). Curves of actual data taken during a flight test during March 1979 are shown for comparison (Reference 5).

The signal acquisition test consisted of setting up an unfading signal level and measuring acquisition time. The initial reference level was set at -107 dBm. Next, the signal level was reduced in 3dB steps

until the acquisition time became extremely long and finally the UHF modem was unable to maintain a lock to the signal. The signal was then set to its nominal level of -107 dBm and fading was added to the signal. The process was repeated by reducing the signal level in 3dB steps until no acquisition occurred. Figure 15 is a plot of the results. Also, tests were conducted with a fixed level of -124 dBm and samples of data under non-fading and fading conditions were taken. A range of acquisition times was determined for both the fading and non-fading situations.

SECTION III
TEST RESULTS

Using the UHF scintillation fading simulator a variety of output data is obtained. For the forward link measurements the curves of the channel error rate, as indicated by the link quality indicator, are shown in Figures 10 and 13. Figure 10 is a baseline curve without fading and Figure 13 is a curve showing the effects of the simulated scintillation fading. A curve of the percent error-free messages received versus average signal level is shown in Figure 14. This curve indicated the difference between no fading and scintillation fading. A plot of actual flight data is also included on this curve.

Figure 15 is a curve of the acquisition time for a particular UHF modem at a nominal signal level with and without fading.

Acquisition times varied from 17 seconds to 58 seconds with no fading on the signal. The mean for the sample was 30 seconds. With fading on the signal, acquisition time varied from 18 seconds to 358 seconds. The mean was 57 seconds. A frequency distribution for both the fading and non-fading conditions are shown in Figures 16 and 17. Figures 18 and 19 are also plots of acquisition time statistics indicated (Reference 4).

SECTION IV
CONCLUSIONS

In order to validate the simulation, a comparison was made between actual bit-error-rate and channel quality (link quality) data taken during the equatorial scintillation testing and during the simulation period. In Figure 14 a dashed curve, derived from actual data taken in equatorial tests is superimposed on the simulation data. The accuracy with which the simulated data reproduces the actual data is very close. A baseline was established and measurements were made using a sample with medium scintillation. The acquisition time data seems reasonable for medium rate scintillation. Future testing will involve slow and fast scintillation as well as more testing on medium scintillation. The results are for the simulation of amplitude effects of the scintillation only. A phase measurement capability has been installed in CSEL where multipath effects as well as amplitude effects may be evaluated.

REFERENCES

1. Allen L. Johnson, UHF Scintillation Fading Simulation System, AFAL-TM-78-1-AAD, Air Force Avionics Laboratory, WPAFB, Ohio, 3 January 1978.
2. Allen L. Johnson, The Effects of Ionospheric Scintillation Fading on Aircraft-to-Satellite Communications, AFAL-TR-78-171, Air Force Avionics Laboratory, WPAFB, Ohio, February 1979.
3. Wade T. Hunt, Scintillation Fading Simulation (Report #1), AFAL-TM-78-12-AAD, Air Force Avionics Laboratory, WPAFB, Ohio, 3 March 1978.
4. Wade T. Hunt, Scintillation Fading Simulation (Report #2), AFAL-TM-78-24 AAD, Air Force Avionics Laboratory, WPAFB, Ohio 23 May 1978.
5. Johnson, Allen, et al., South American Test Report, AFAL-TM-79-14-AAD, Air Force Avionics Laboratory, WPAFB, Ohio, 9 July 1979.



Figure 1. Picture of CSEL

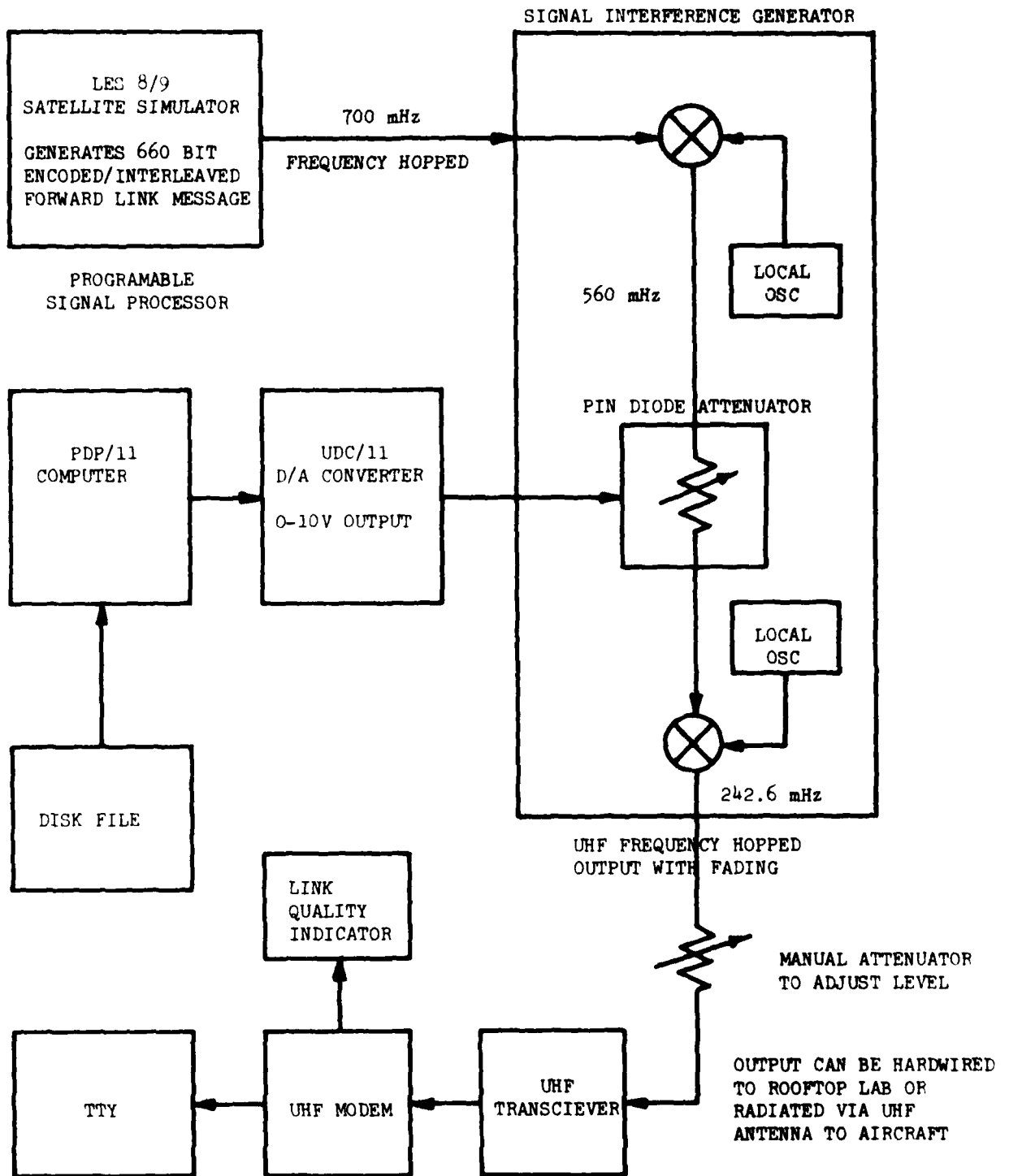

Figure 2. Forward Link Scintillation Fading Simulation



Figure 3. Spectrum and Interference Generator

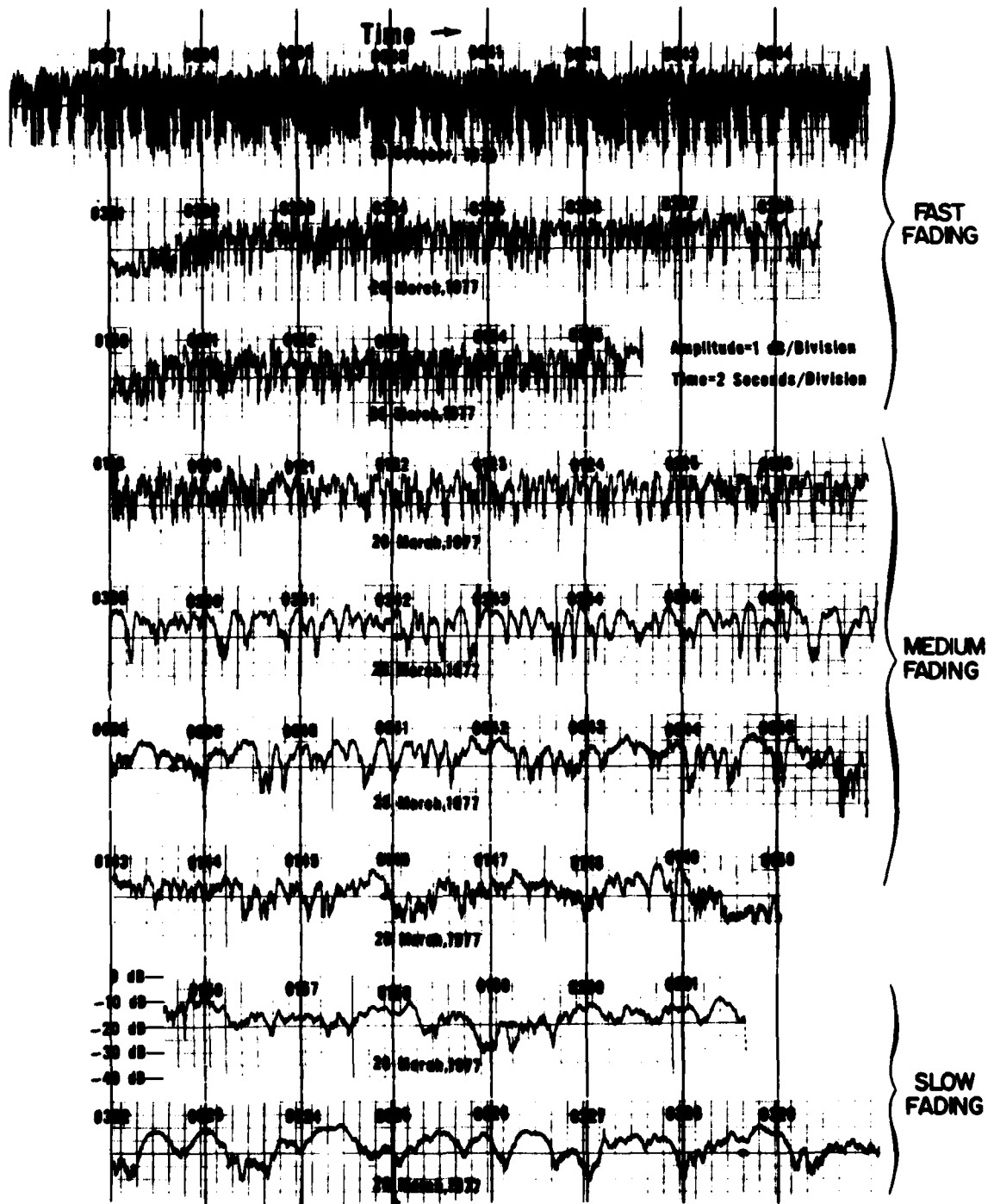

Figure 4. Samples of Rapid, Medium and Very Slow Scintillation Fading



Figure 5. Rooftop Facility



Figure 6. UHF Modem



Figure 7. Programmable Signal Processor

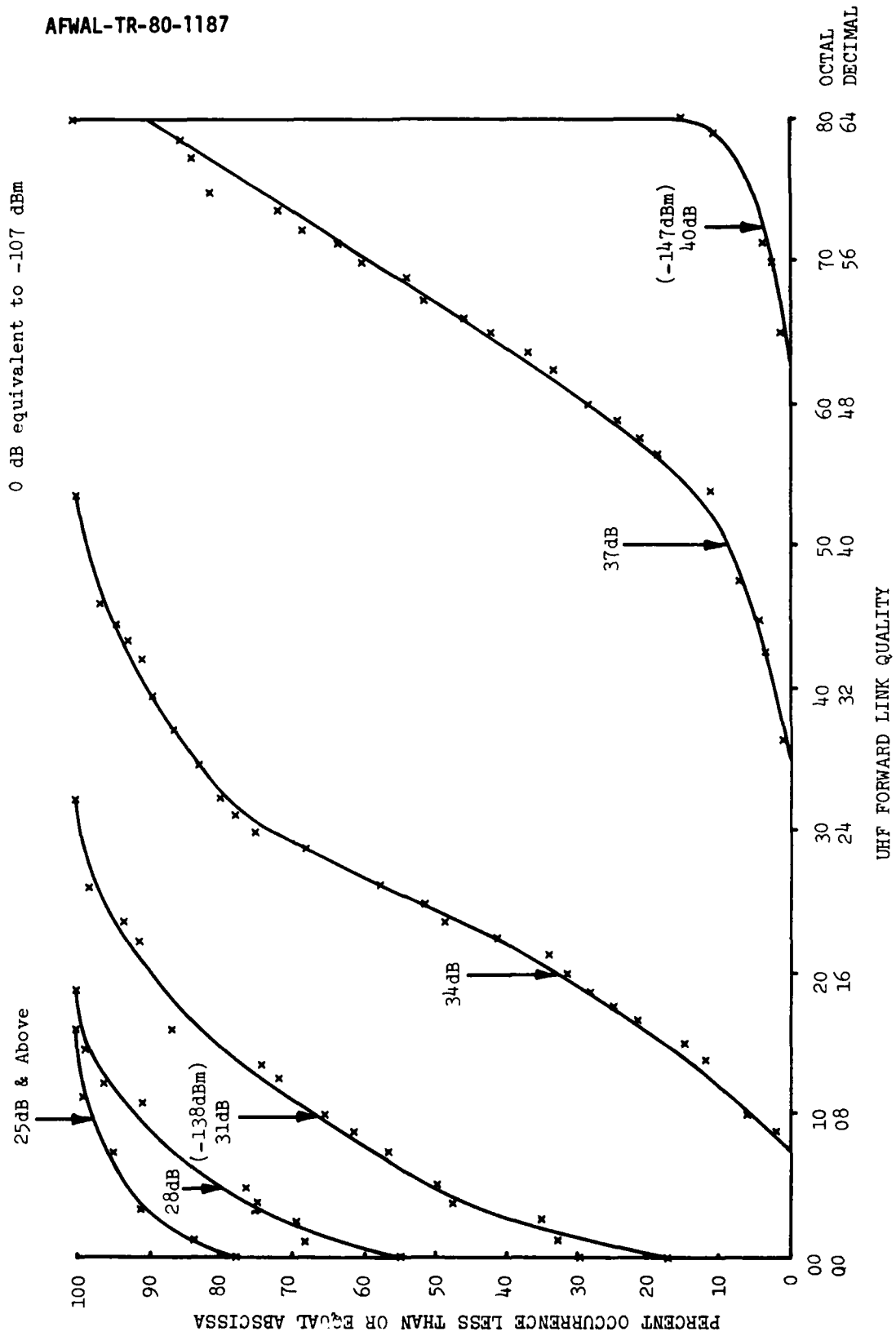

Figure 10. Simulation Without Fade (16 FEB '78 CSEL & ROOFTOP)

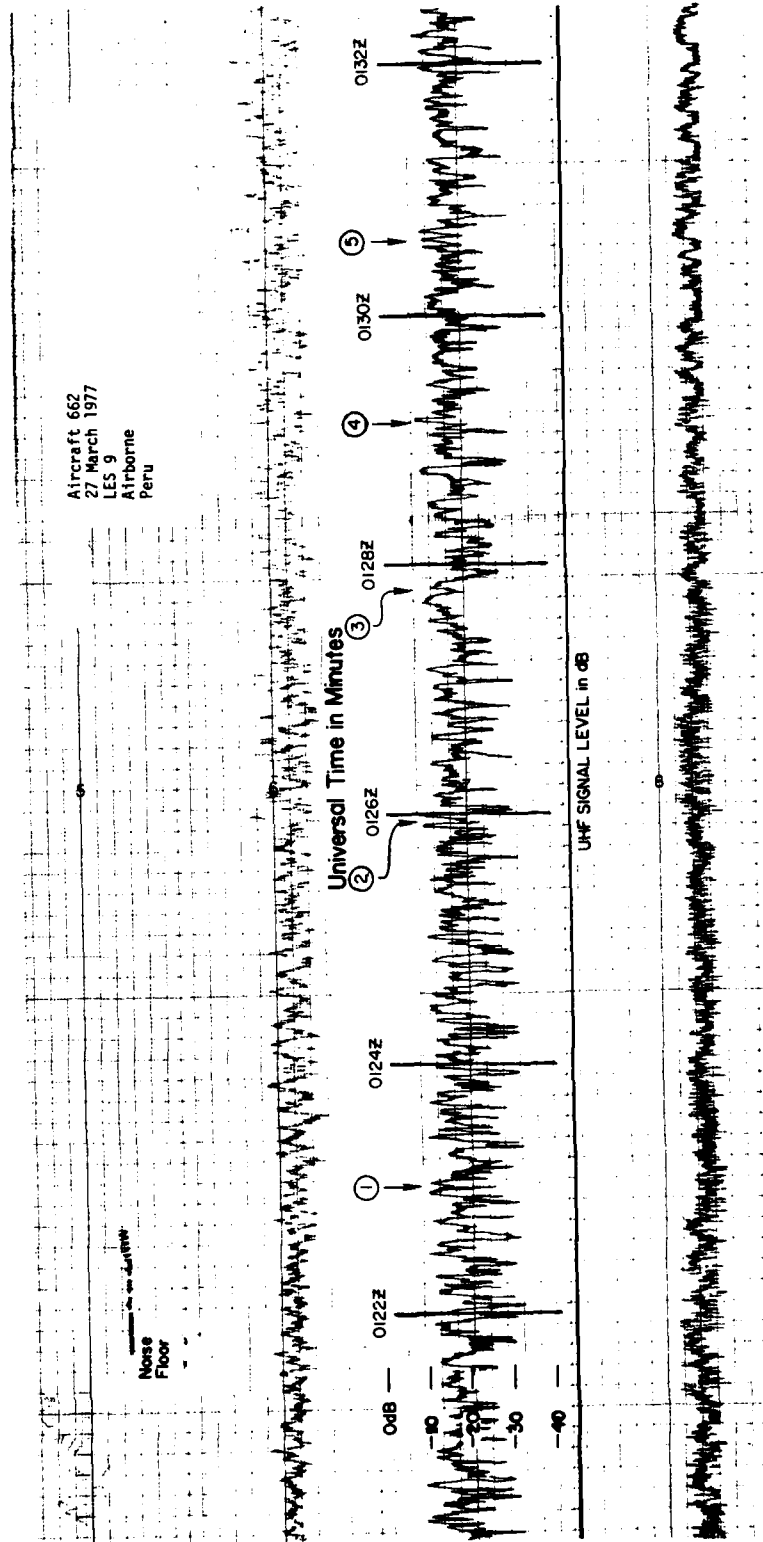

Figure 11. Ionospheric Scintillation Fading From LES 9

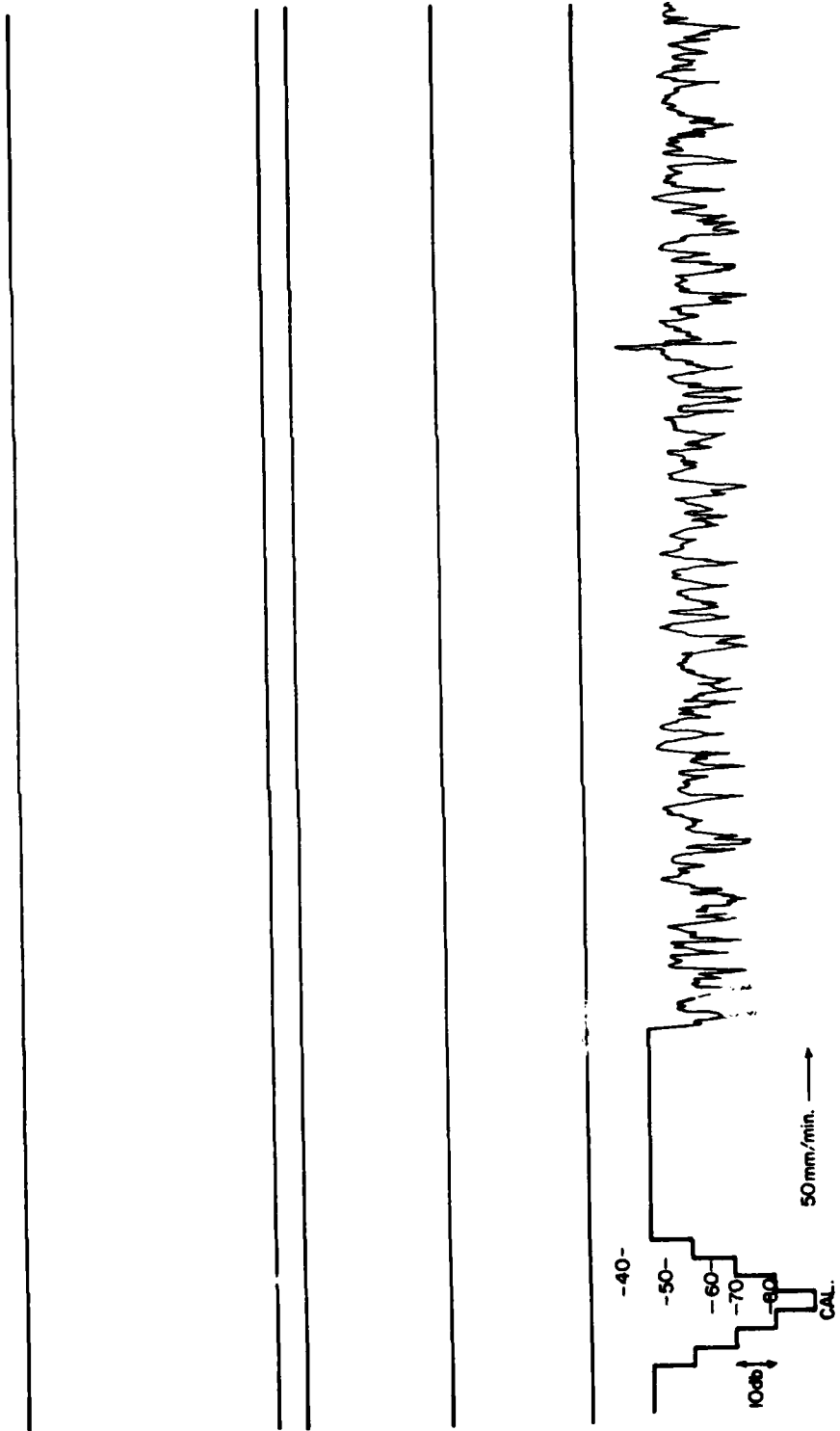

Figure 12. 10 Minute Sample of Medium Fade Data

0 dB equivalent to -107dBm

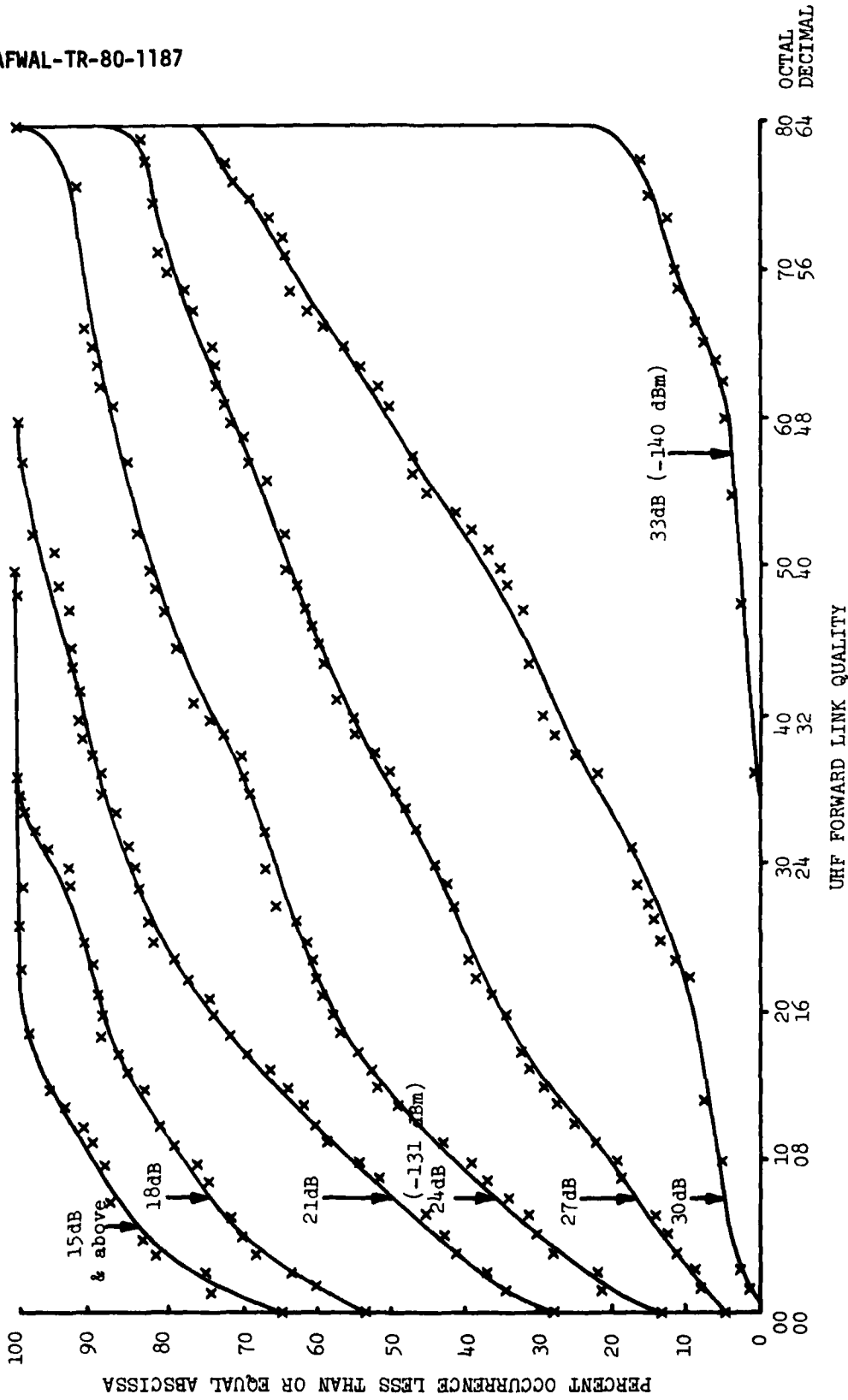

Figure 13. Simulation with Fading (16 FEB '78 CSEL & ROOFTOP)

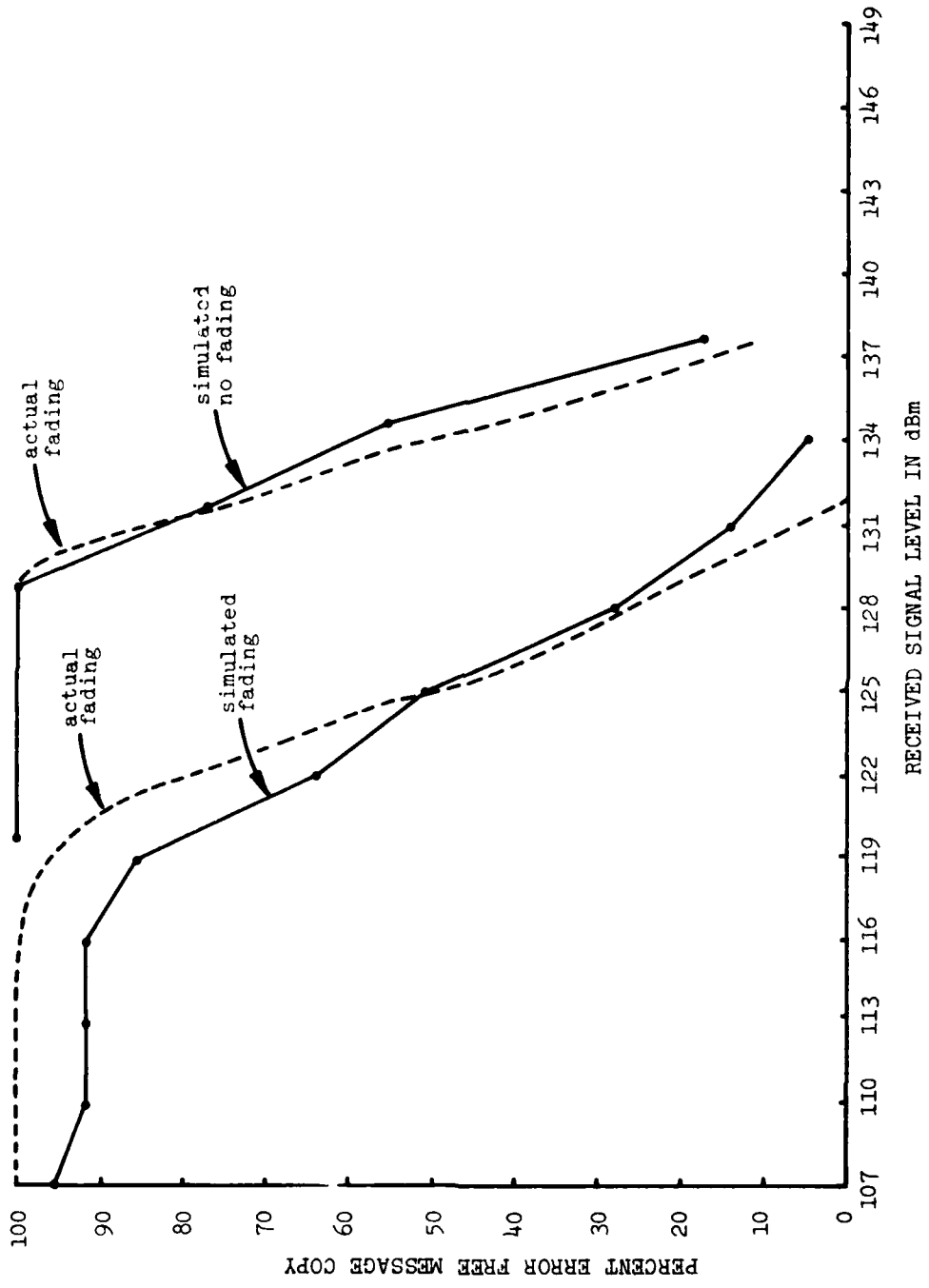

Figure 14. Forward Link Percent Message Copy (Simulation CSEL & ROOFTOP 16 FEB '78)

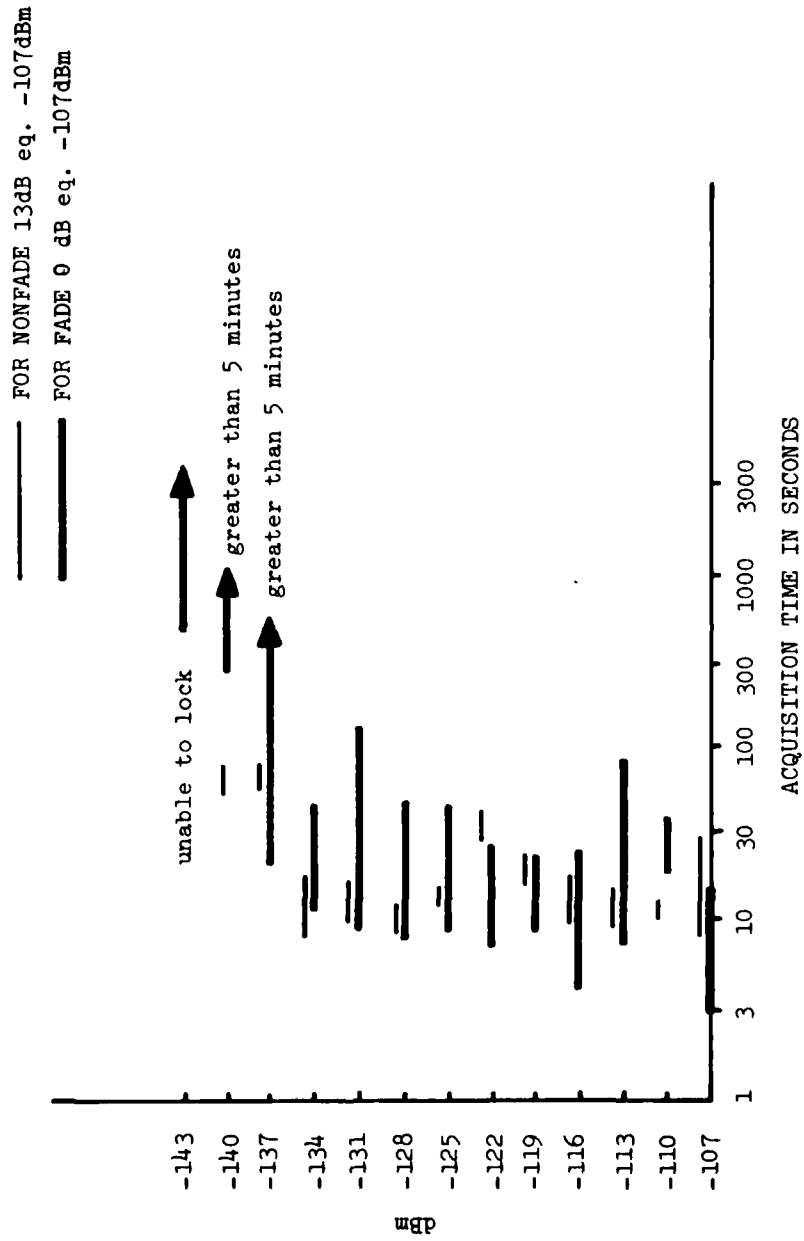

Figure 15. Baseline Acquisition Test Results (21 March 1978)

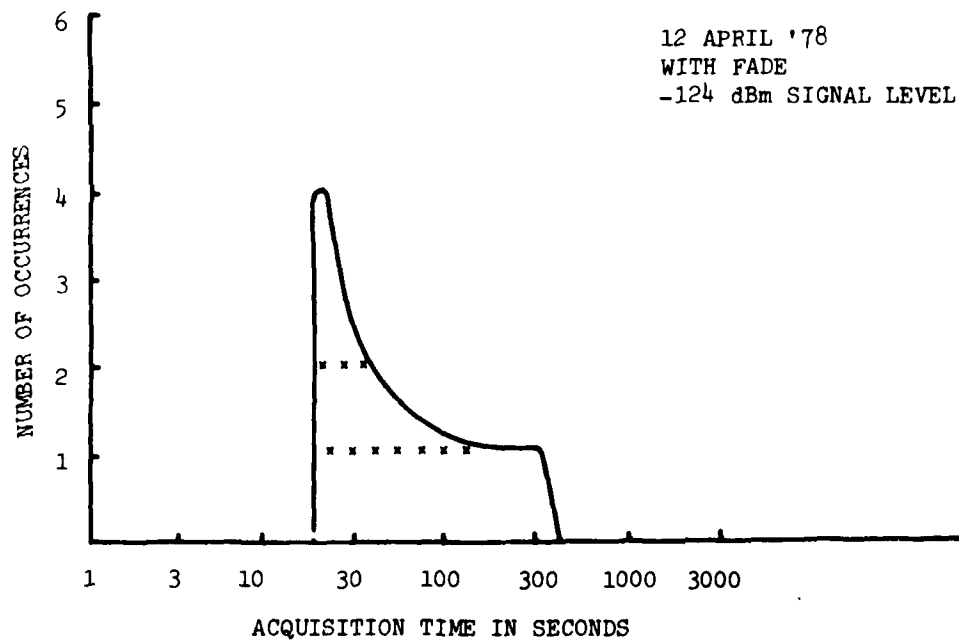
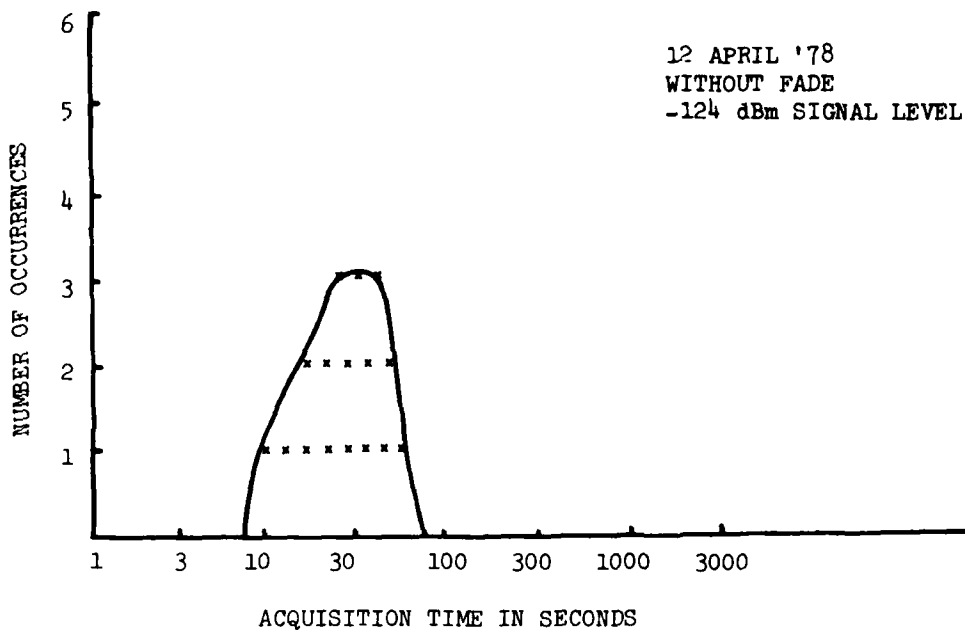

Figure 16. UHF Modem Acquisition Time

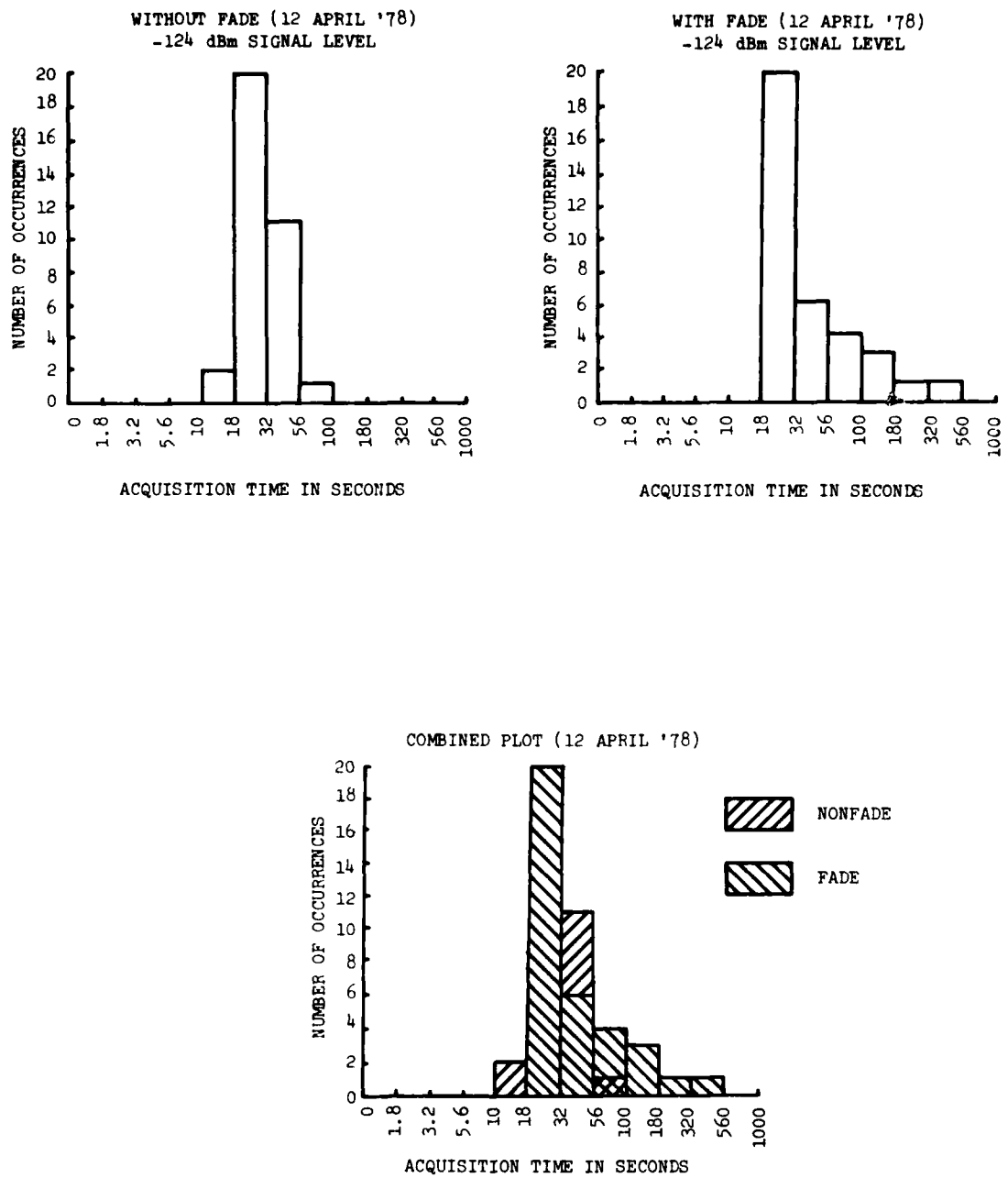

Figure 17. UHF Modem Acquisition Time

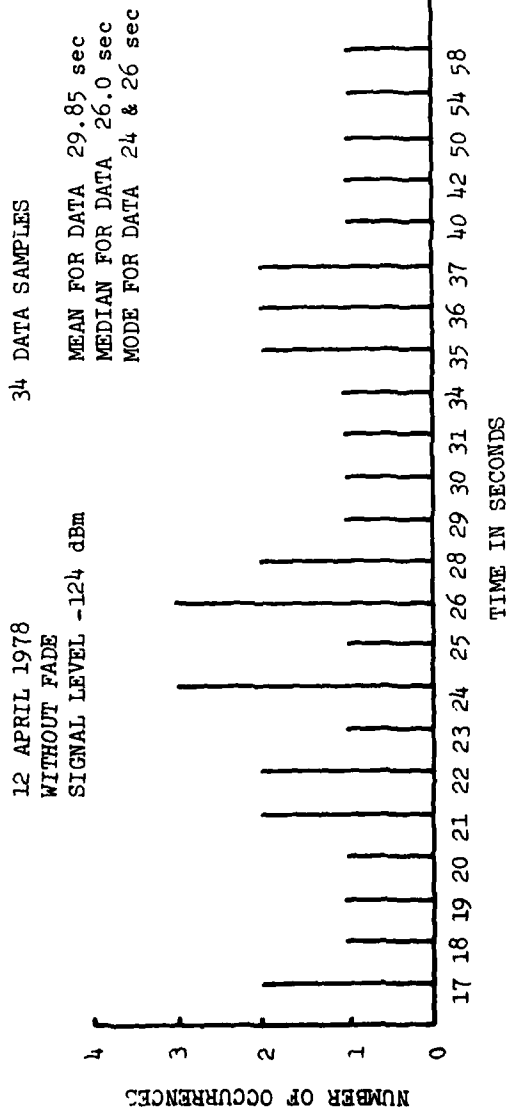

Figure 18. Acquisition Time Statistics Without Fade

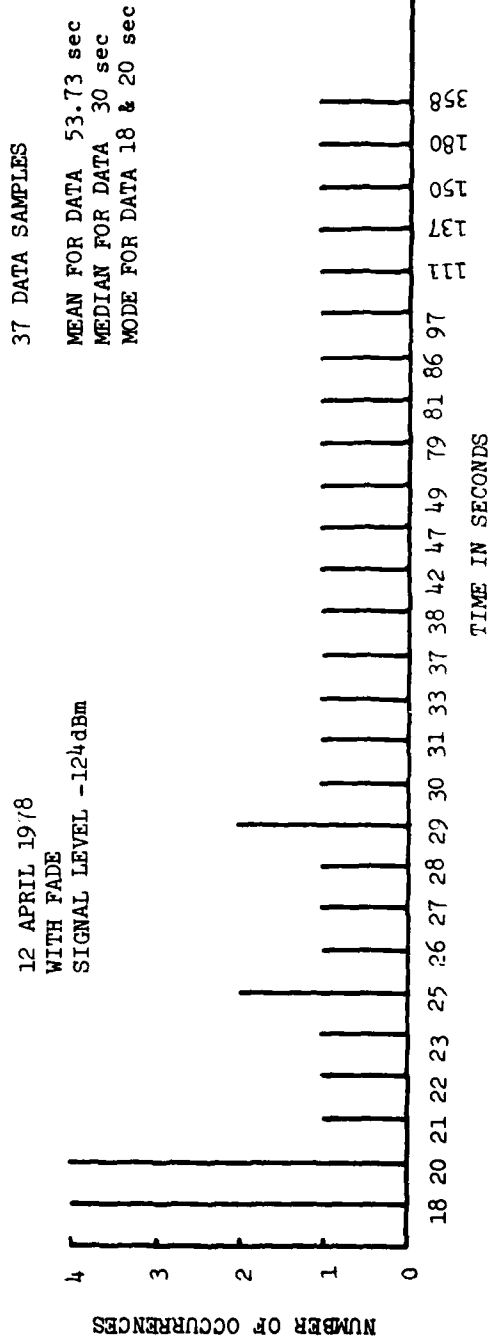

Figure 19. Acquisition Time Statistics With Fade

DATE
FILMED
88