

AD-A098 707

HARRY DIAMOND LABS ADELPHI MD F/G 9/5
POST-TUNED MICROSTRIP ANTENNAS FOR FREQUENCY-AGILE AND POLARIZA--ETC(U)
MAR 81 D H SCHAUBERT, F G FARRAR

UNCLASSIFIED

HDL-TM-81-8

NL

1-1
AD-A098 707



END
SERIAL
FILMED
8-8H
DTIC

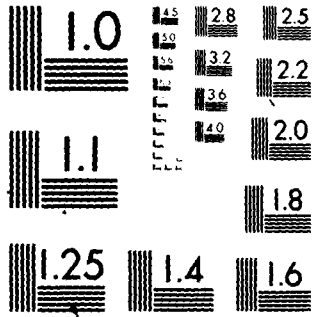

MICROCOPY RESOLUTION TEST CHART
NATIONAL BUREAU OF STANDARDS-1963-A

AD A 098207

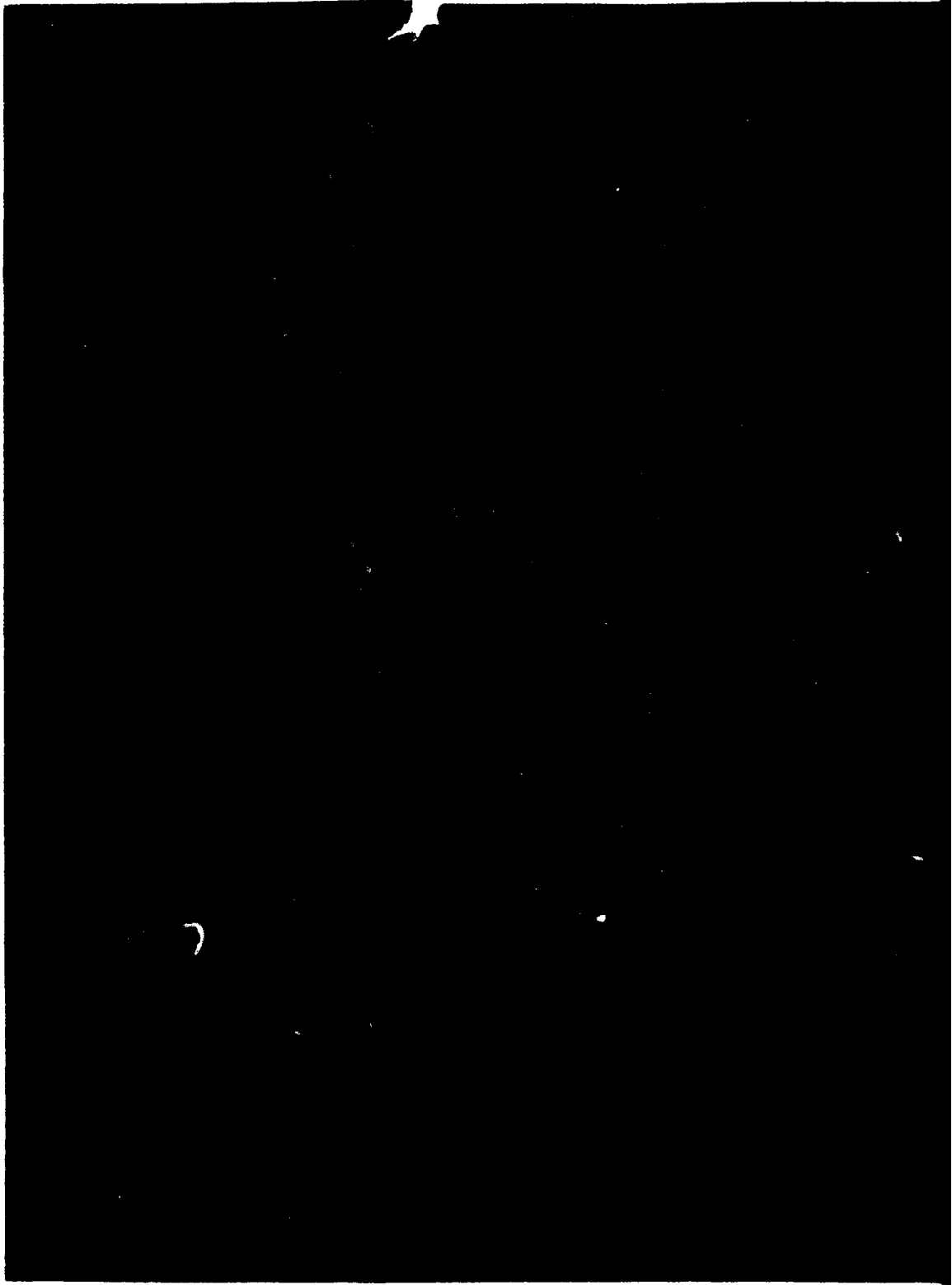

7

UNCLASSIFIED

SECURITY CLASSIFICATION OF THIS PAGE (When Data Entered)

REPORT DOCUMENTATION PAGE		READ INSTRUCTIONS BEFORE COMPLETING FORM	
1. REPORT NUMBER HDL-TM-81-8	2. GOVT ACCESSION NO. AD-A09 870 7(9)	3. RECIPIENT'S CATALOG NUMBER	
4. TITLE (and Subtitle) Post-Tuned Microstrip Antennas for Frequency-Agile and Polarization-Diverse Applications	5. TYPE OF REPORT & PERIOD COVERED Technical Memorandum		
6. PERFORMING ORG. REPORT NUMBER		8. CONTRACT OR GRANT NUMBER(s)	
7. AUTHOR(s) Daniel H./Schaubert Arthur R./Sindoris Frederick G./Farrar Scott T./Hayes		10. PROGRAM ELEMENT, PROJECT, TASK AREA & WORK UNIT NUMBERS Program Ele: 62603A	
9. PERFORMING ORGANIZATION NAME AND ADDRESS Harry Diamond Laboratories 2800 Powder Mill Road Adelphi, MD 20783		11. REPORT DATE March 1981	12. REPORT DATE
11. CONTROLLING OFFICE NAME AND ADDRESS U.S. Army Armament R&D Command Dover, NJ 07801		13. NUMBER OF PAGES 30	15. SECURITY CLASS. (of this report) UNCLASSIFIED
14. MONITORING AGENCY NAME & ADDRESS (if different from Controlling Office) 12) 32		15a. DECLASSIFICATION DOWNGRADING SCHEDULE	
16. DISTRIBUTION STATEMENT (of this Report) Approved for public release; distribution unlimited.			
17. DISTRIBUTION STATEMENT (of the abstract entered in Block 20, if different from Report)			
18. SUPPLEMENTARY NOTES DRCMS Code: 612603H181411 Pron: 1A934367011AA9 DA Proj: 1L162603AH18 HDL Project: A18915			
19. KEY WORDS (Continue on reverse side if necessary and identify by block number) Microstrip antennas Frequency-agile antennas Polarization-diverse antennas Conformal antennas Printed circuit antennas			
20. ABSTRACT (Continue on reverse side if necessary and identify by block number) A technique is investigated for controlling the operating frequency and polarization of microstrip antennas. The control is achieved by the placement of shorting posts at appropriate locations within the antenna's boundaries. By changing the number and locations of the posts, the operating frequency can be tuned over a 1.5-to-1 range, and the polarization can be changed from horizontal to vertical, right-hand circular, or			

DD FORM 1473 1 JAN 73 EDITION OF 1 NOV 65 IS OBSOLETE

UNCLASSIFIED SECURITY CLASSIFICATION OF THIS PAGE (When Data Entered)

163050 fu

UNCLASSIFIED

SECURITY CLASSIFICATION OF THIS PAGE(When Data Entered)

20. ABSTRACT (Cont'd)

left-hand circular. All these changes are obtained without significantly altering the input impedance or radiation patterns of the antenna and without increasing the complexity of the external microwave feed network. Also, the frequency and polarization can be electronically controlled by the use of microwave switching diodes for the shorting posts. Antennas that have two feeds and operate simultaneously in two orthogonal polarizations have been constructed with the capability to switch between linear and circular polarizations. Also, a thin, frequency-scanned array has been built with the frequency-agile microstrip elements.

Accession No.	
DTIC GRA&I	<input checked="" type="checkbox"/>
DTIC TAB	<input type="checkbox"/>
Unannounced	<input type="checkbox"/>
Justification	
Distribution/	
Availability Codes	
Avail and/or	
Special	
A	

UNCLASSIFIED

SECURITY CLASSIFICATION OF THIS PAGE(When Data Entered)

CONTENTS

	<u>Page</u>
1. INTRODUCTION	5
2. FREQUENCY-AGILE ANTENNA	6
3. POLARIZATION DIVERSITY	10
4. OTHER CONFIGURATIONS	14
4.1 Circular Microstrip Antenna	14
4.2 Simple, Polarization-Diverse Configuration	15
4.3 Centerline-Fed Antennas	17
4.4 Single- and Multiple-Post Antennas	18
4.5 Antennas with More Posts and Less Conductor	19
4.6 Other Potential Configurations	23
5. FREQUENCY-SCANNED ARRAY	24
6. CONCLUSIONS	24
LITERATURE CITED	27
SELECTED BIBLIOGRAPHY	28
DISTRIBUTION	29

FIGURES

1 Typical microstrip antenna with shorting posts for changing operating frequency	7
2 Transmission-line model for calculating operating frequency and input impedance of frequency-tuned antenna	8
3 Operating frequency and VSWR of frequency-tuned antenna	9
4 Typical radiation patterns of 6.2- x 9.0-cm frequency-tuned microstrip antenna on 1.6-mm Teflon fiberglass substrate	10
5 Square-patch antenna with four pairs of posts for obtaining four different polarizations	11
6 Typical spin-linear radiation patterns of 6.2-cm square patch in horizontal and vertical polarized configurations	12

FIGURES (Cont'd)

	<u>Page</u>
7 Typical spin-linear radiation patterns of 6.2-cm square patch in left-circular and right-circular polarized configurations....	13
8 Measured axial ratio of 6.15-cm square patch antenna with a pair of symmetrically located posts	15
9 Circular microstrip antenna with posts for polarization diversity	16
10 Typical spin-linear radiation patterns of circular microstrip antenna	16
11 Simple, polarization-diverse antenna designed for bias insertion through rf feed	17
12 Centerline-fed, polarization-diverse antennas	17
13 Measured axial ratio of antenna with one post near the feed and one post opposite the feed	18
14 Measured operating frequency and VSWR of antenna with one post near the feed and one post opposite the feed	19
15 Operating frequency of 6.2- × 9.0-cm antenna	20
16 Rectangular microstrip antenna with a portion of conductor removed to lower fundamental frequency and posts added to tune frequency upward	20
17 Two modes of radiation for 6.2- × 9.0-cm modified antenna	21
18 Tilted radiation pattern of 6.2- × 9.0-cm modified antenna in configuration that supports two modes	22
19 Radiation pattern of 6.2- × 9.0-cm modified antenna with posts located as shown in figure 16	22
20 One-quarter-wavelength microstrip antenna with frequency tuning posts	23
21 Microstrip antenna with multiple post locations to provide both frequency agility and polarization diversity	24
22 Prototype array of post-tuned elements for frequency-scanned applications	25
23 Typical E-plane radiation patterns of eight-element, frequency-scanned array with uniform amplitude distribution	26

1. INTRODUCTION

The microstrip antenna has been shown to be an excellent radiator for many applications requiring only a narrow bandwidth. It is rugged and can be fabricated economically with standard printed-circuit techniques. As with other single-element antennas, a single microstrip radiator has a moderately broad radiation pattern, but arrays with high gain have been demonstrated.

In its simplest form, the microstrip antenna radiates linearly polarized signals over a bandwidth of 1 to 2 percent. By modifying its geometry, it is possible to obtain circularly polarized radiation or a shift in the operating frequency. Since these techniques require permanent physical changes to the antenna, they are not amenable to electronic control of the antenna's performance. The antenna's performance can be electronically controlled by varactors or by variable length transmission lines. Varactors require a precise bias voltage control, and switched length transmission lines require space outside the basic microstrip antenna's boundaries. These are potential disadvantages and can be overcome by a simpler control mechanism such as shorting posts (e.g., switching diodes) at appropriate points within the strip boundary. By changing the number and location of the shorting posts, both the frequency and polarization of the microstrip antenna can be controlled. Also, Malagisi¹ has shown that a phase-shifting reflector can be built by using circular microstrip elements with shorting posts.

We have experimentally investigated the post-loading technique. For ease of experimentation, machine screws were used as removable shorting posts. A single microstrip element was made to radiate fields that are polarized horizontal linear, vertical linear, right-hand circular, or left-hand circular. Also, single elements and an eight-element array were tuned to operate over a 1.5-to-1 range of frequencies. This frequency tuning was accomplished without the serious degradation of input impedance that was observed by Kernweis and McIlvenna. A simple analytical model has been developed and used to generate useful design data for the post-loaded microstrip antennas.

More detailed discussions of these properties of microstrip antennas are referenced in the Selected Bibliography (p 29).

¹Carmen S. Malagisi, *Electronically Scanned Microstrip Antenna Array*, U.S. Patent No. 4,053,895 (11 October 1977).

2. FREQUENCY-AGILE ANTENNA

The operating characteristics of a typical rectangular patch microstrip antenna are determined by the antenna's size and feed location and by the substrate permittivity. The antenna in figure 1, without the shorting posts, is a typical configuration designed for linear x-polarized radiation. The antenna operates at a fundamental frequency, f_0 ,

$$f_0 = \frac{c}{2a\sqrt{\epsilon_r}} \quad (1)$$

where the patch length, a , is approximately one-half wavelength in the dielectric. At this frequency, the voltage and current distributions on the patch resemble those of an open-circuited microstrip transmission line with propagation in the $\pm x$ -directions. The input impedance of the antenna is determined primarily by the patch width, b , and the feed location, f .²

The addition of shorting posts along the centerline, $y = b/2$, increases the operating frequency of the antenna. This frequency increase may be explained by considering the transmission-line model for the microstrip antenna.³ This model is depicted in figure 2, where Z_0 is the characteristic impedance of a microstrip line of width b on the substrate material. The length extensions, Δl , account for fringe-field reactance at the open circuit ends, and the conductance, G , accounts for radiation from the ends. The formulas of Hammerstad⁴ were used to calculate Z_0 and Δl , and Harrington's formula⁵ for slot conductance was used for G .

$$Z_0 = \frac{377}{\sqrt{\epsilon_e}} \left[b/t + 1.393 + 0.667 \ln(b/t + 1.444) \right]^{-1} \quad (2)$$

$$\Delta l = 0.412t \frac{(\epsilon_e + 0.3)(b/t + 0.262)}{(\epsilon_e - 0.258)(b/t + 0.813)} \quad (3)$$

²Y. T. Lo, D. Solomon, and W. F. Richards, *Theory and Experiment of Microstrip Antennas*, IEEE Trans. Ant Prop, AP-27 (March 1979), 137-145.

³Anders G. Derneryd, *Linearly Polarized Microstrip Antennas*, IEEE Trans. Ant Prop AP-24 (November 1976), 846-851.

⁴E. O. Hammerstad, *Equations for Microstrip Circuit Design*, Proc. 5th European Microwave Conference (September 1975), 268-272.

⁵R. F. Harrington, *Time-Harmonic Electromagnetic Fields*, McGraw-Hill, New York (1961), 183.

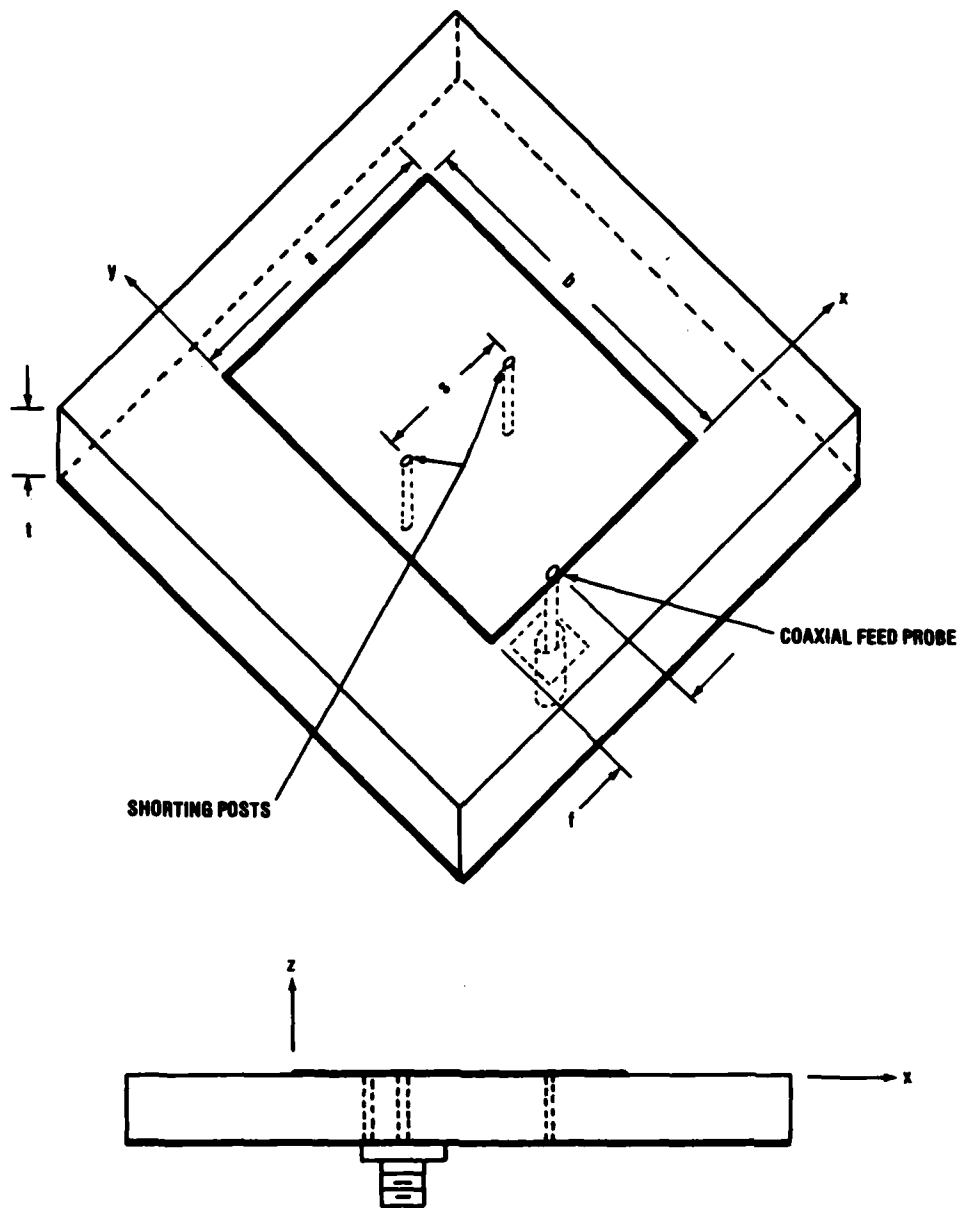

Figure 1. Typical microstrip antenna with shorting posts for changing operating frequency.

where

$$\epsilon_e = \frac{\epsilon_r + 1}{2} + \frac{\epsilon_r - 1}{2(1 + 10t/b)^{1/2}} \quad (4)$$

$$G = \frac{\pi b}{377\lambda_0} \left[1 - \frac{(kt)^2}{24} \right] \quad (5)$$

$$\approx 0.0083 b/\lambda_0, \quad t/\lambda_0 \ll 1 .$$

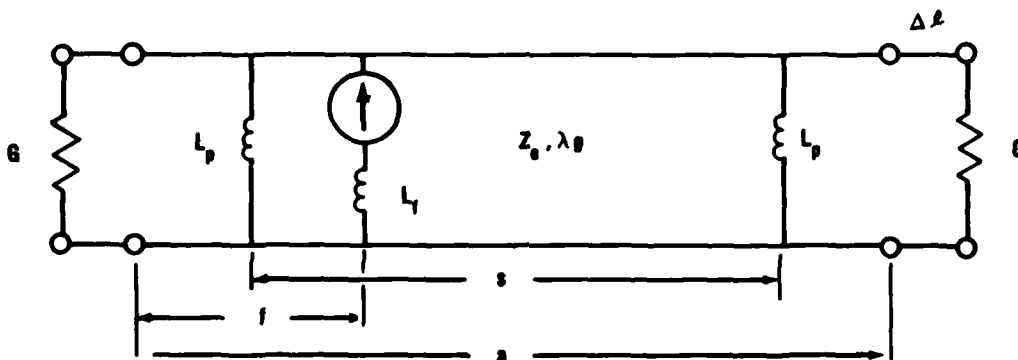

Figure 2. Transmission-line model for calculating operating frequency and input impedance of frequency-tuned antenna.

The rf feed is represented by a current source with a series inductor to represent the feed probe inductance.⁶ The shorting posts are represented as shunt inductances at the locations of the posts. The inductive reactance of the posts and the feed probe is calculated from the formula,

$$X_L = \frac{377}{\sqrt{\epsilon_r}} \tan \frac{2\pi t}{\lambda_0} . \quad (6)$$

The input impedance and radiation loss are calculated from this model. Plots of the operating frequency and voltage standing wave ratio (VSWR) are shown in figure 3. The agreement between the calculated and

⁶Keith R. Carver and Edgar L. Coffey, *Theoretical Investigation of the Microstrip Antenna*, New Mexico State University Physical Science Laboratory, Technical Report PT-00929 (January 1979), prepared for U.S. Army Research Office Grant DAAG29-78-G-0082.

measured results is quite good and demonstrates that this transmission-line model yields useful design data for the post-tuned microstrip antenna.

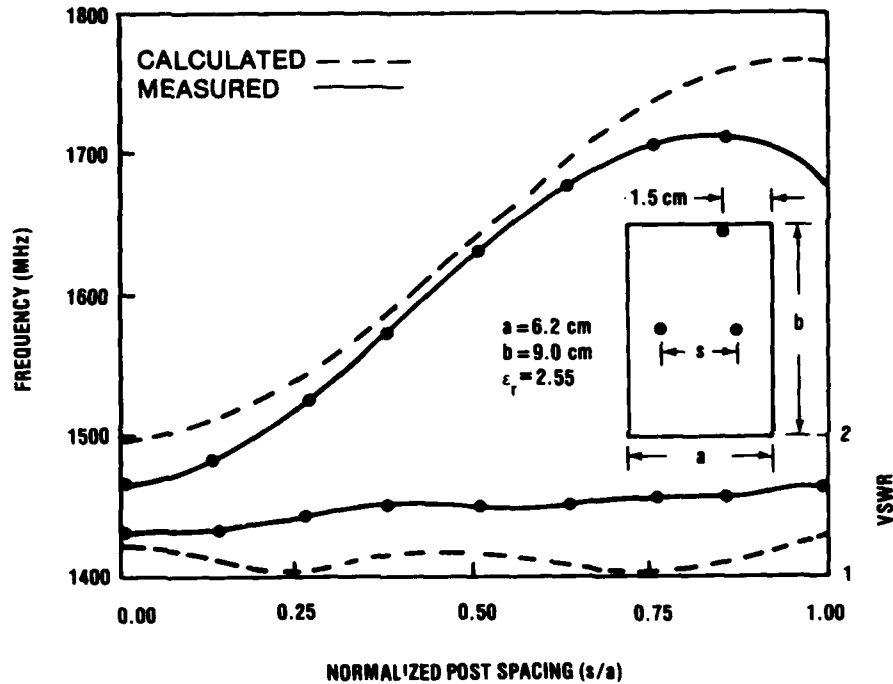

Figure 3. Operating frequency (upper curves) and VSWR (lower curves) of frequency-tuned antenna.

The range of frequency tuning achieved by a pair of posts along the centerline is about 20 percent, but tuning ranges in excess of 50 percent have been achieved by adding more posts. These additional posts may be placed along the centerline, $y = b/2$ (fig. 1), or offset from the centerline along $y = b/2 \pm c$. (When placing posts away from the centerline, it is preferred that they be added in pairs symmetric about the centerline. This avoids the introduction of cross-polarized signals.) The radiation patterns in figure 4 demonstrate that the antenna's performance is not degraded by the shorting posts. The bandwidth ($VSWR < 2$) is approximately 1 percent at each operating frequency.

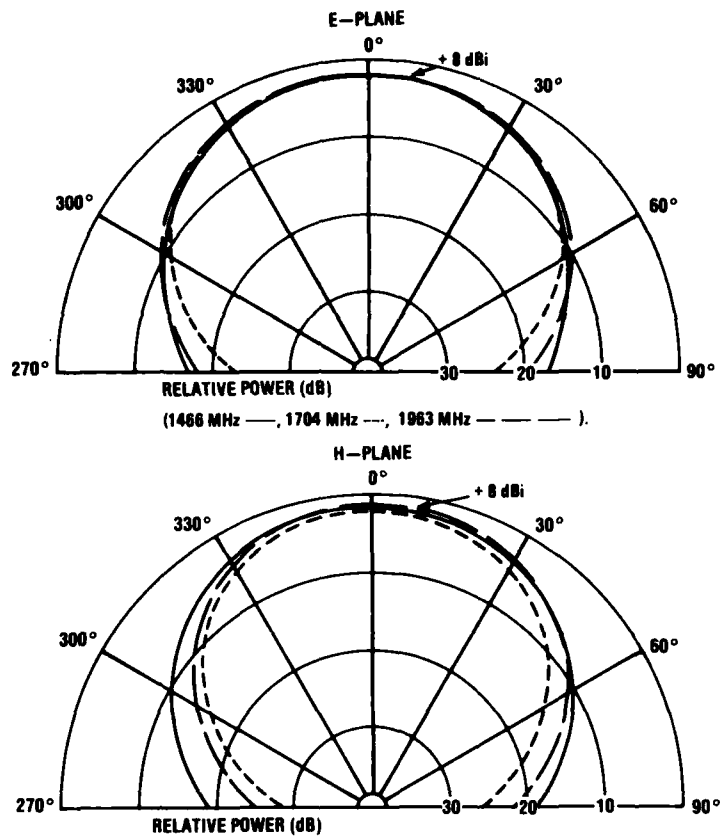

Figure 4. Typical radiation patterns of 6.2×9.0 -cm frequency-tuned microstrip antenna on 1.6-mm Teflon fiberglass substrate. Substrate and ground plane are 22 cm square. Peak gains are approximately 8 dBi.

3. POLARIZATION DIVERSITY

The polarization of the microstrip antenna also can be selectively altered by proper location of the shorting posts.⁷ Of particular interest is the square patch fed along a diagonal with shorting posts along one of the centerlines (fig. 5). This antenna will radiate x- or y-

⁷Daniel H. Schaubert and Frederick G. Farrar, *Microstrip Antenna with Polarization Diversity*, Program and Abstracts of National Radio Science Meeting USNC/URSI (November 1979), 139.

oriented linear polarization, or right- or left-circular polarization, depending upon the locations of the posts. Typical radiation patterns obtained by using a spinning, linearly polarized receive antenna are shown in figures 6 and 7. The antenna configuration in figure 6 is linearly polarized. The pattern shapes are different because figure 6(a) is an E-plane pattern cut and figure 6(b) is an H-plane pattern cut. In figure 7, the antenna is configured for circular polarization. The axial ratio is less than 3 dB over a wide sector around the zenith. (The axial ratio does not become infinite at the horizon because the ground plane is relatively small.)

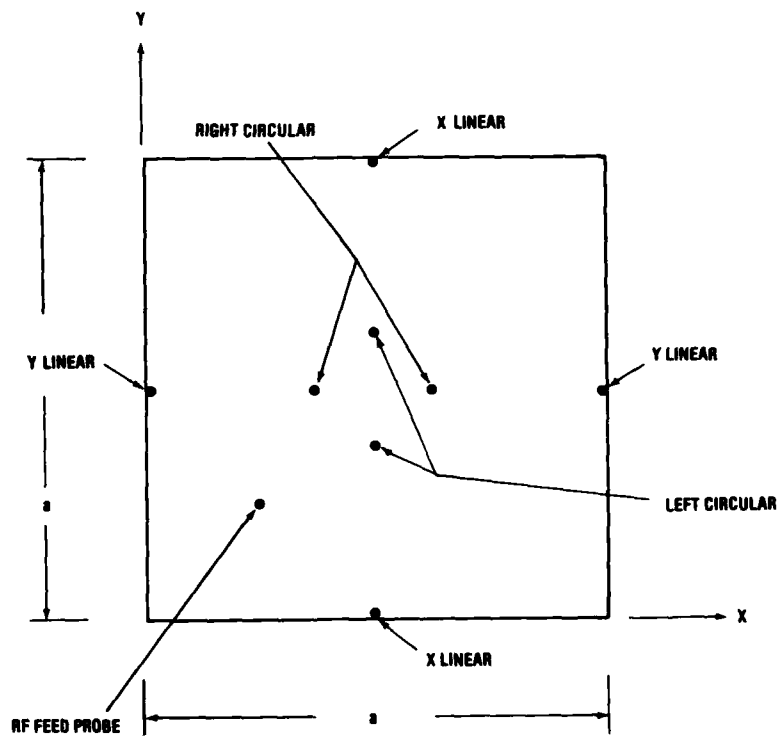

Figure 5. Square-patch antenna with four pairs of posts for obtaining four different polarizations.

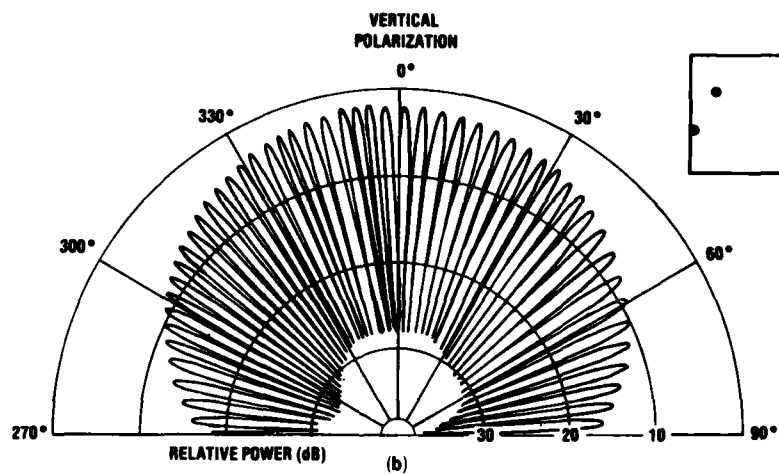
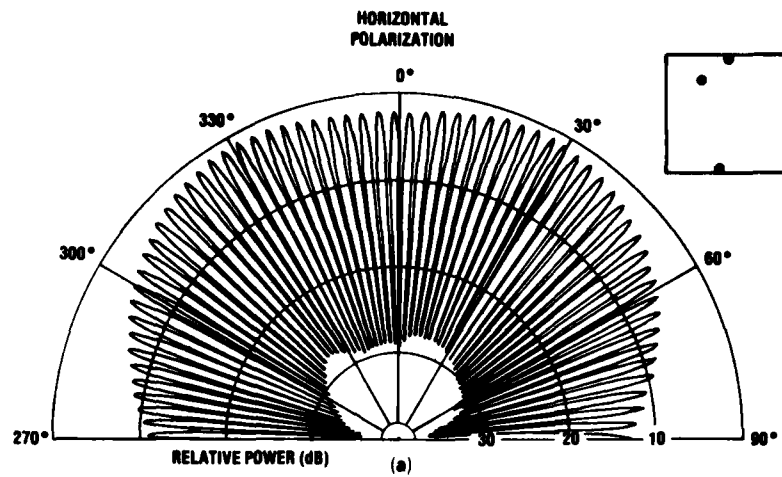

Figure 6. Typical spin-linear radiation patterns of 6.2-cm square patch in horizontal and vertical polarized configurations. Substrate and ground plane are 22 cm square.

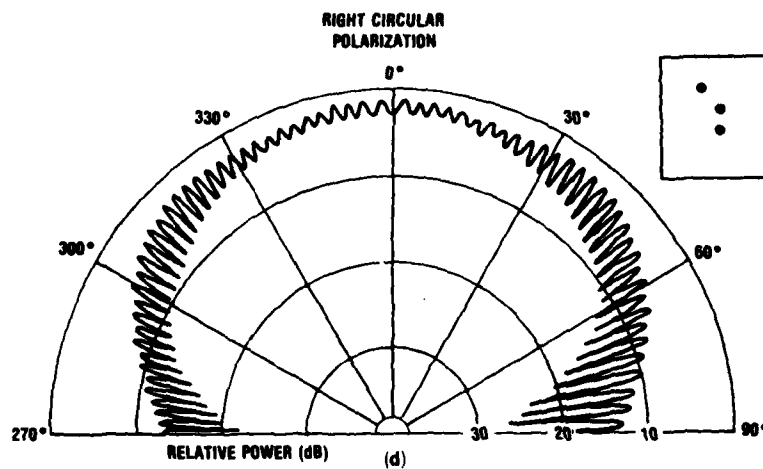
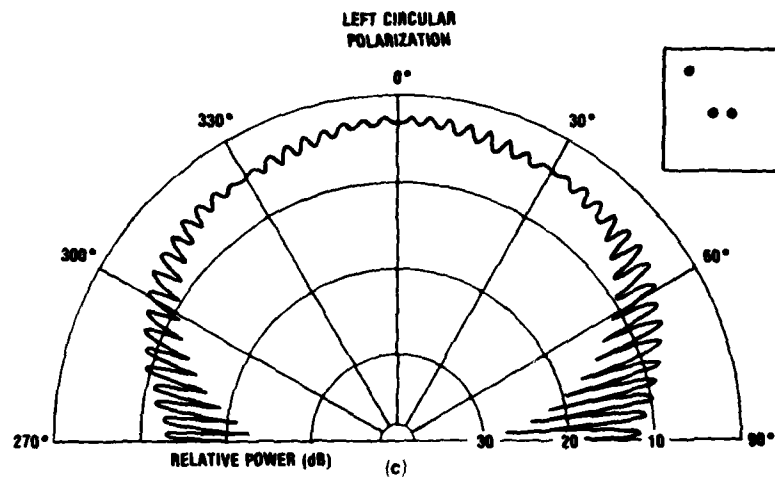

Figure 7. Typical spin-linear radiation patterns of 6.2-cm square patch in left-circular and right-circular polarized configurations.

These polarization changes can be explained by considering the frequency-tuning effects described above. The square patch without shorting posts supports both x-oriented and y-oriented modes, which have the same resonant frequency. Since the feed probe is located on the diagonal of the patch, both the x- and y-oriented modes are excited with equal amplitude and phase. By adding shorting posts along the center-

line $x = a/2$ (fig. 5), the resonant frequency of the y-oriented mode can be raised without affecting the x-oriented mode. Similarly, by adding posts along $y = a/2$, the resonant frequency of the x-oriented mode can be raised without affecting the y-oriented mode. Therefore, a single mode (x- or y-oriented) may be selected by shifting the resonant frequency of the undesired mode far above that of the desired mode. This large frequency shift is obtained by placing shorting posts at or near the edges of the patch. The result is linear polarization.

Circular polarization may be obtained by exciting both the x- and y-oriented modes with equal amplitudes, but with 90-deg phase difference. This can be accomplished by raising the resonant frequency of one mode slightly above the other and operating at a frequency between the two resonances. Then the input impedance of one mode is inductive and the other mode is capacitive. By adjusting the difference between the resonant frequencies, both modes can be excited with equal amplitudes and a 90-deg phase difference.

Figure 8 shows the measured axial ratio of a typical antenna as the separation between a pair of shorting posts is changed. When $s/a = 0$, the posts are at the center and they do not affect either mode. In this case, the antenna is linearly polarized along the diagonal with the feed. When $s/a = 0.09$, the resonant frequencies of the two modes are offset enough to create a phase difference of approximately 90 deg, and the antenna is circularly polarized. As the posts are moved further apart, the resonant frequency of the vertical mode is further increased and the antenna's polarization becomes horizontal linear. The input impedance of the antenna changes as the posts are moved, but the VSWR remains very good for all senses of polarization. (Although the best circular polarization occurs at a frequency slightly above the resonance for the linear polarization, the bandwidth of the linearly polarized antenna is adequate to permit it to operate at the same frequency as the circularly polarized antenna.)

4. OTHER CONFIGURATIONS

Several alternative configurations of the frequency-agile and polarization-diverse antennas have been designed, built, and tested. These alternative configurations are useful because they increase the versatility of the post-tuned microstrip antenna.

4.1 Circular Microstrip Antenna

Circular microstrip antennas perform well as polarization-diverse radiators. The antenna depicted in figure 9 can provide all four types of polarization, as shown in figure 10. The 6.2-cm-diam

antenna's performance is similar to that of a 5.3-cm square antenna, which would operate at 1724 MHz and would occupy approximately the same surface area.

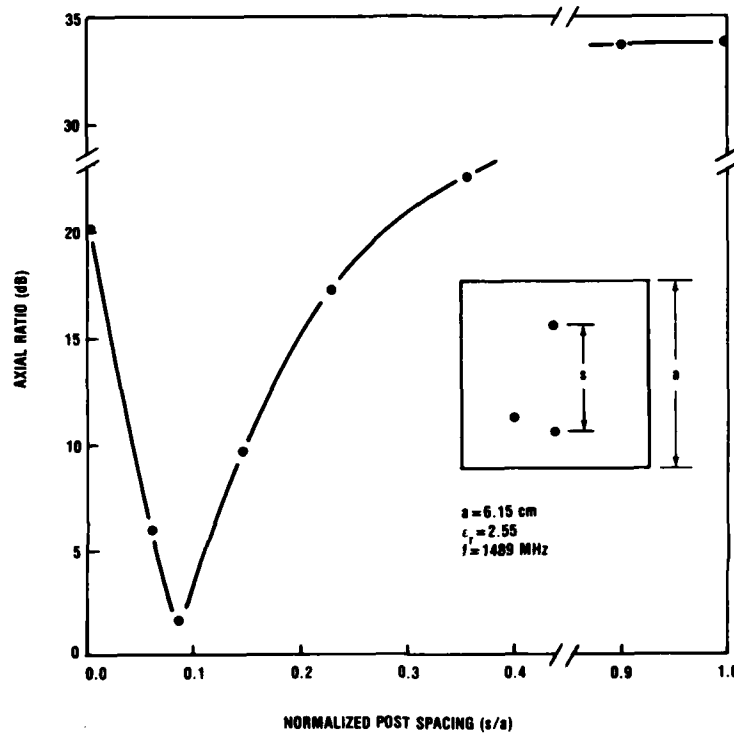

Figure 8. Measured axial ratio of 6.15-cm square patch antenna with a pair of symmetrically located posts.

4.2 Simple, Polarization-Diverse Configuration

A particularly simple form of the polarization-diverse antenna with only two polarization states can be implemented as shown in figure 11. A positive or negative dc bias can be inserted through the rf feed to select the desired polarization. Two orthogonal, linear polarizations are obtained from the antenna in figure 11, but any combination of two polarizations can be obtained by properly locating the diodes.

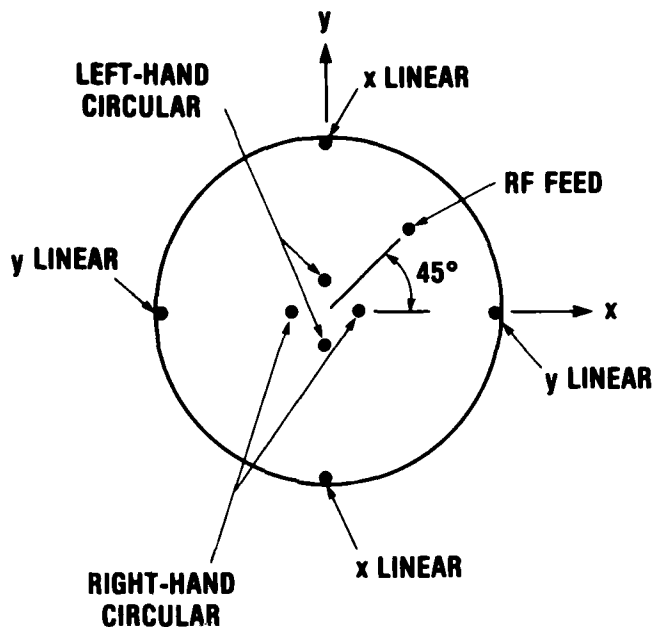

Figure 9. Circular microstrip antenna with posts for polarization diversity.

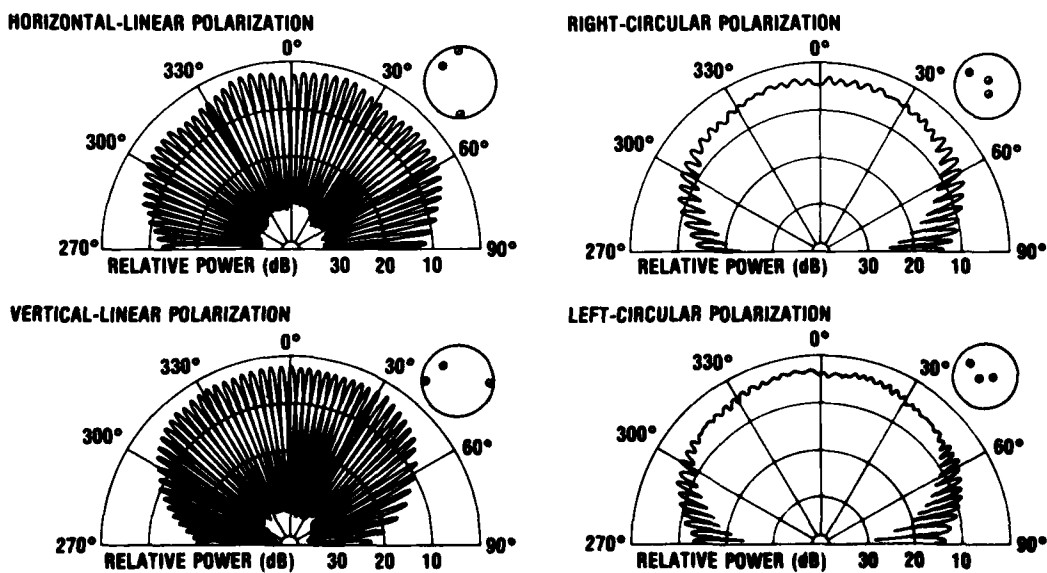

Figure 10. Typical spin-linear radiation patterns of circular microstrip antenna.

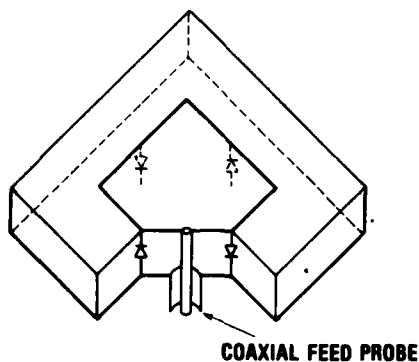

Figure 11. Simple, polarization-diverse antenna designed for bias insertion through rf feed.

4.3 Centerline-Fed Antennas

Another form of polarization-diverse antennas is square patches fed along a centerline. These patches (fig. 12(a)) provide one linear polarization (no posts) and both circular polarizations by means of shorting posts located along the diagonals of the patch. The addition of a second feed (fig. 12(b)) permits simultaneous operation in two polarizations. A dual-feed, 6.2-cm square patch with coaxial probe feeds demonstrated dual polarization performance with greater than 30-dB isolation between the two linear polarizations and greater than 20-dB isolation between the two circular polarizations.

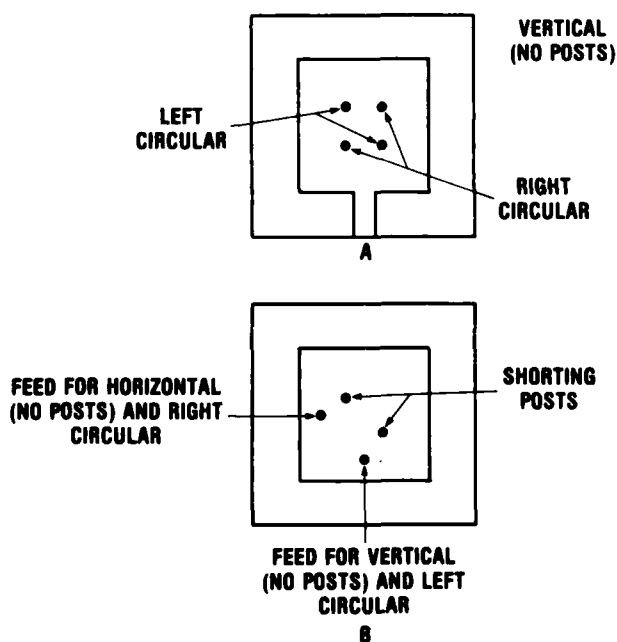

Figure 12. Centerline-fed, polarization-diverse antennas: (a) three-polarization antenna, (b) switchable, dual-polarization antenna.

4.4 Single- and Multiple-Post Antennas

The frequency tuning and polarization control described above use pairs of posts. Similar results can be obtained by using only one post or more than two posts. Figure 13 shows the measured axial ratio of a diagonal-fed square patch with a single post. The axial ratio is essentially the same for the post located either near or opposite the feed probe. Circular polarization (2-dB axial ratio) is obtained when the single post is approximately twice as far from the center as when a pair of posts is used (see fig. 8).

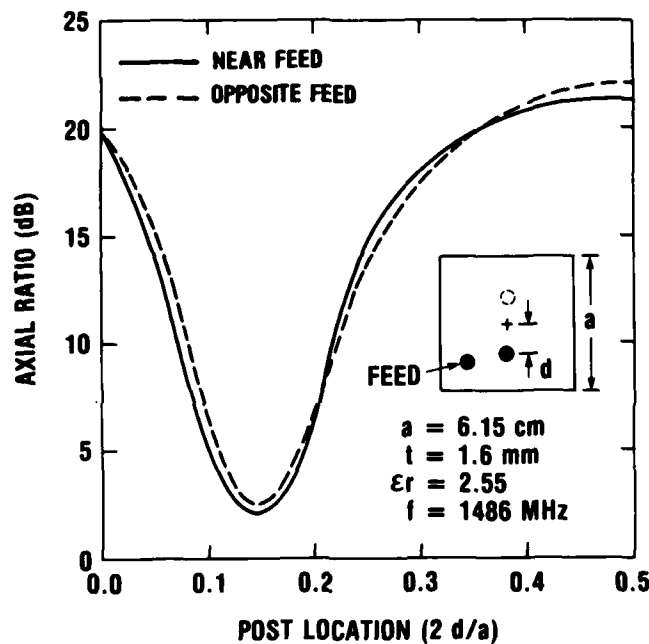

Figure 13. Measured axial ratio of antenna with one post near the feed and one post opposite the feed.

The frequency-tuning effects of a single post are shown in figure 14. The total tuning range is less than for a pair of posts and the VSWR varies more.

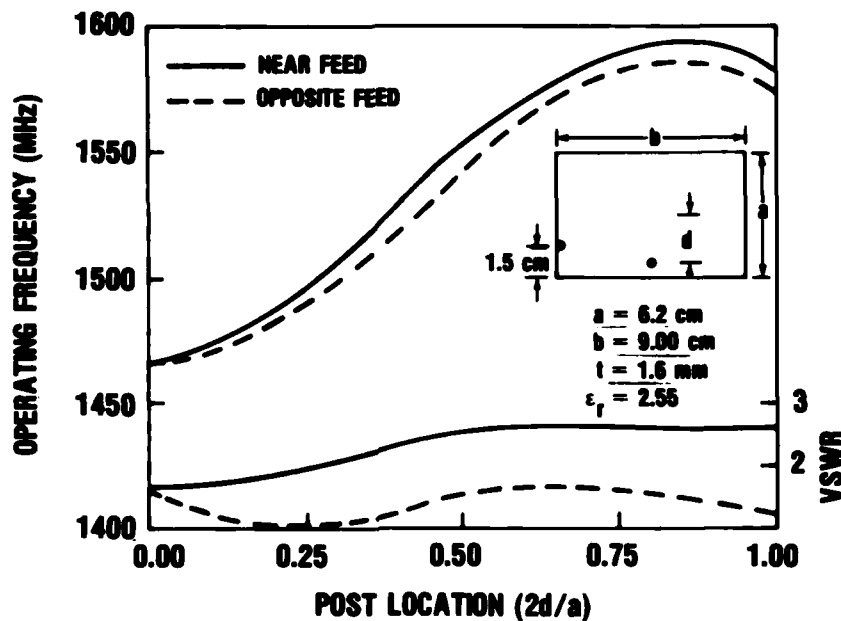

Figure 14. Measured operating frequency and VSWR of antenna with one post near the feed and one post opposite the feed.

The maximum frequency of the 6.2- × 9.0-cm antenna with a pair of posts is 1711 MHz (fig. 3). By using more posts, this maximum frequency can be increased to 2120 MHz. Figure 15 shows the measured operating frequency of the 6.2- × 9.0-cm patch for a variety of post locations. The VSWR and radiation patterns are good at all frequencies. Attempts to increase the operating frequency beyond 2120 MHz by changing the number and location of the posts have resulted in a deterioration of the impedance match. Therefore, the useful operating frequency range of this antenna is 1466 to 2120 MHz.

4.5 Antennas with More Posts and Less Conductor

Since the length of the post-tuned, frequency-agile antenna must be one-half wavelength at the lowest frequency in its tuning range, it is longer than a standard microstrip antenna designed for the highest frequency. This can create a problem in arrays of frequency-agile antennas, because the element size limits the minimum element spacing and, therefore, controls the locations of the grating lobes. However, this problem can be alleviated by combining the post tuning with Kerr's technique (listed in Selected Bibliography) of removing a portion of the conducting patch in order to lower the operating frequency. An element of this type is depicted in figure 16. Without posts, this antenna

operates at 1166 MHz, 20 percent below the frequency of a standard 6.2-cm-long patch. With posts in the indicated positions, the antenna operates at 1675 MHz, which represents a frequency-tuning range of 1.4 to 1.

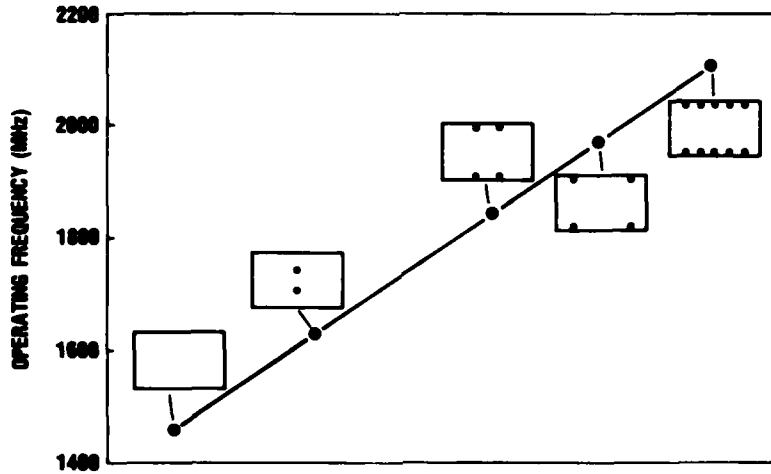

Figure 15. Operating frequency of 6.2- x 9.0-cm antenna (1.6-mm Teflon fiberglass substrate) for various post configurations.

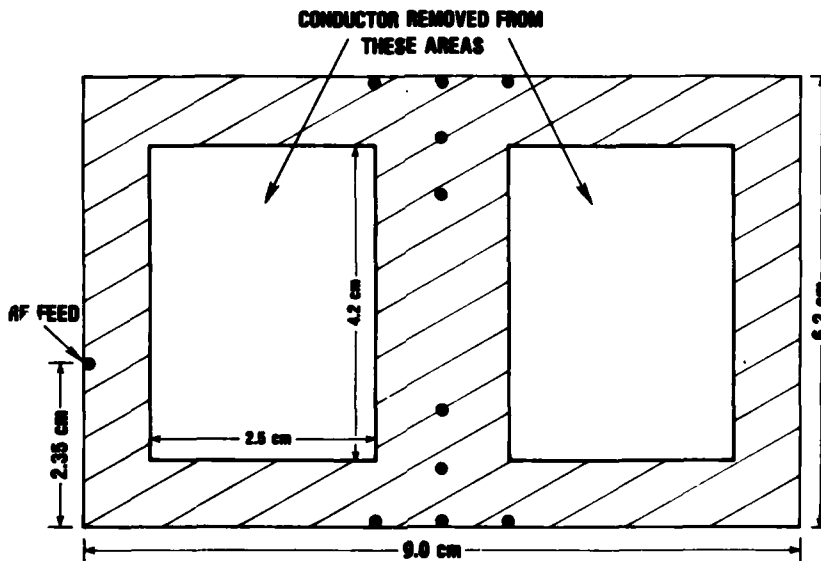

Figure 16. Rectangular microstrip antenna with a portion of conductor removed to lower fundamental frequency and posts added to tune frequency upward.

The input impedance and radiation patterns of this modified antenna are generally good across its entire frequency range. However, the radiation pattern sometimes deteriorates due to the presence of another radiation mode. This mode is present in most of the microstrip antennas, but it usually occurs at a frequency that is significantly different from that of the desired radiation mode. The two different radiation modes are shown in figure 17. Figure 18 shows the radiation pattern of the antenna for a post configuration that supports both the desired radiation mode and the additional mode at 1675 MHz. The combination of these modes produces a tilted beam that may be undesirable. (On the other hand, this tilted beam can be useful for some applications.) Nonetheless, the antenna can be configured to suppress the undesired mode and yield a nearly symmetric radiation pattern at 1675 MHz (fig. 19), or at any other frequency within its tuning range.

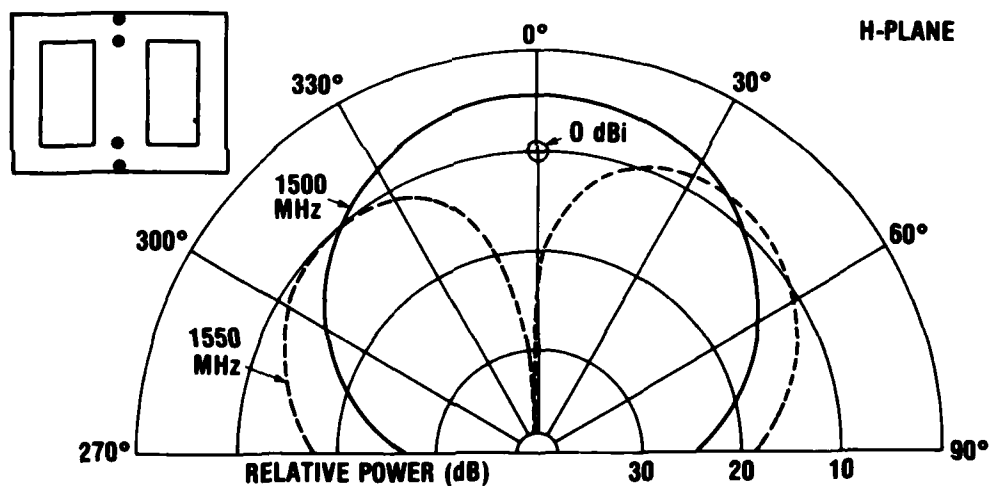

Figure 17. Two modes of radiation for 6.2- x 9.0-cm modified antenna.

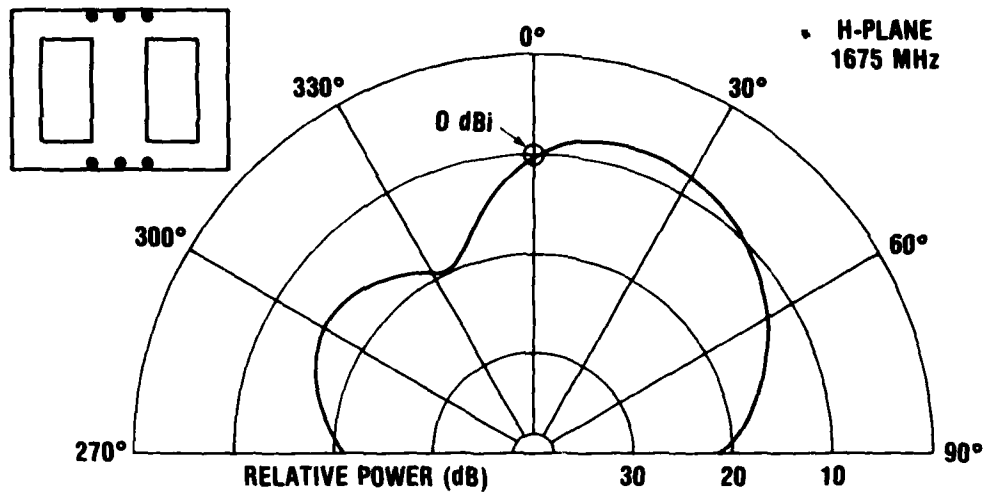

Figure 18. Tilted radiation pattern of 6.2- x 9.0-cm modified antenna in configuration that supports two modes.

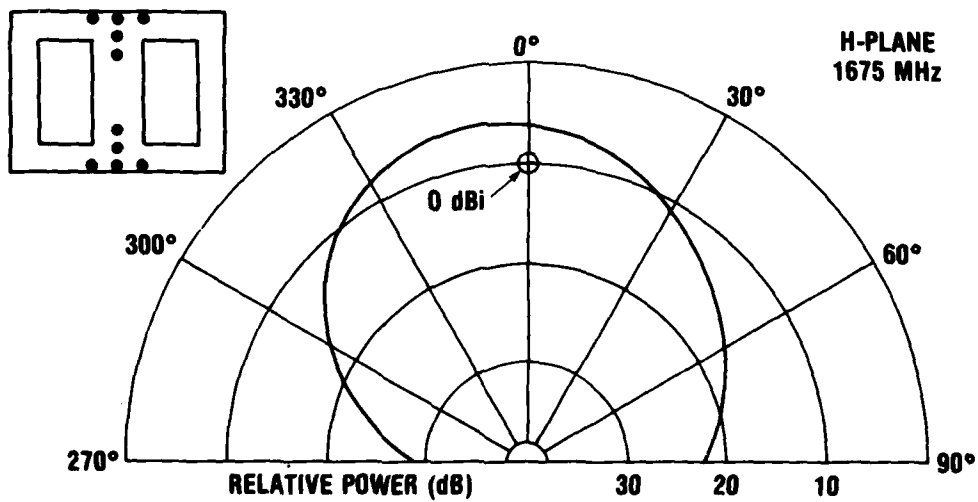

Figure 19. Radiation pattern of 6.2- x 9.0-cm modified antenna with posts located as shown in figure 16.

4.6 Other Potential Configurations

Other potential configurations of the post-tuned antennas include a frequency-agile, one-quarter-wavelength antenna (fig. 20) and a frequency-agile antenna with polarization diversity. This latter type of antenna could be implemented by feeding a square microstrip along its diagonal and locating shorting posts at various positions along the two centerlines (fig. 21). Since the posts along $x = a/2$ affect only the y -oriented modes and the posts along $y = a/2$ affect only the x -oriented modes, post locations may be selected to obtain (1) one of these linearly polarized modes at each specified frequency or (2) both of the modes with the correct amplitude and phase for circular polarization at each frequency. Of course, many different posts are needed in order to obtain all polarizations at several different frequencies.

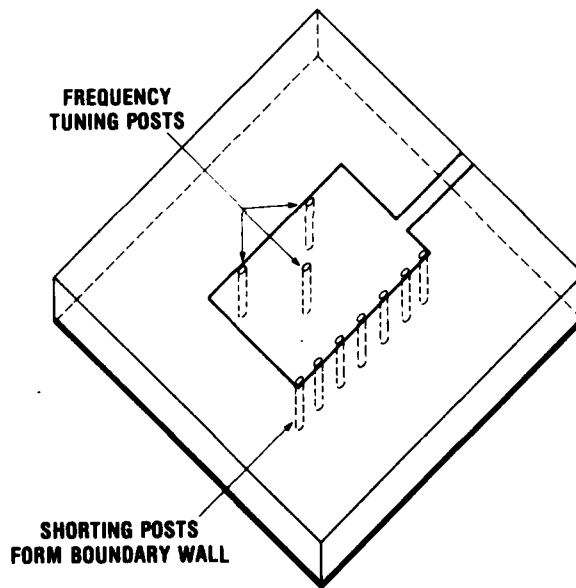

Figure 20. One-quarter-wavelength microstrip antenna with frequency tuning posts.

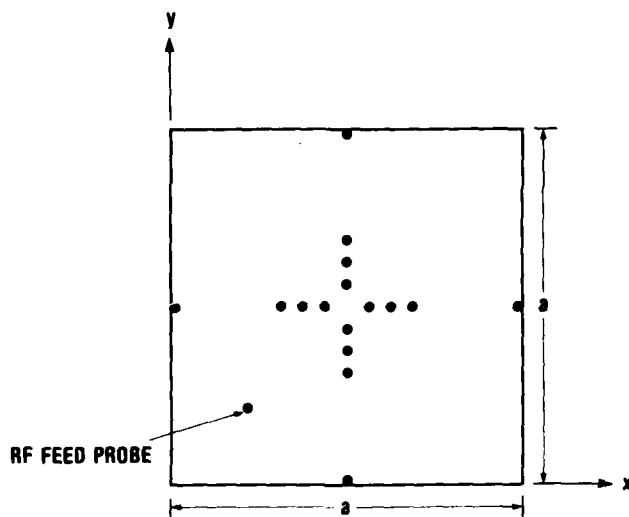

Figure 21. Microstrip antenna with multiple post locations to provide both frequency agility and polarization diversity.

5. FREQUENCY-SCANNED ARRAY

Thin, conformal, frequency-scanned arrays can also be built with the frequency-agile microstrip antenna. An eight-element linear array consisting of 4.32×6.16 -cm patches has been fabricated on 1.6-mm (1/16-in.) thick Teflon fiberglass substrate. This experimental array (fig. 22) is tuned with small machine screws inserted into holes in the antennas. A corporate feed network that provides progressive phase shift was used to create an antenna that scans ± 45 degrees from broadside as the frequency varies from 2.08 to 2.89 GHz (fig. 23). This type of antenna with diode tuning posts would perform well in a computer-controlled system that simultaneously increments the operating frequency of the antenna and the transmitter/receiver.

6. CONCLUSIONS

The operating frequency and polarization of microstrip antennas can be conveniently controlled by inserting shorting posts at appropriate locations within the antenna's boundary. From the use of microwave

switching diodes, an electronically controlled frequency-agile or polarization-diverse antenna can be obtained.

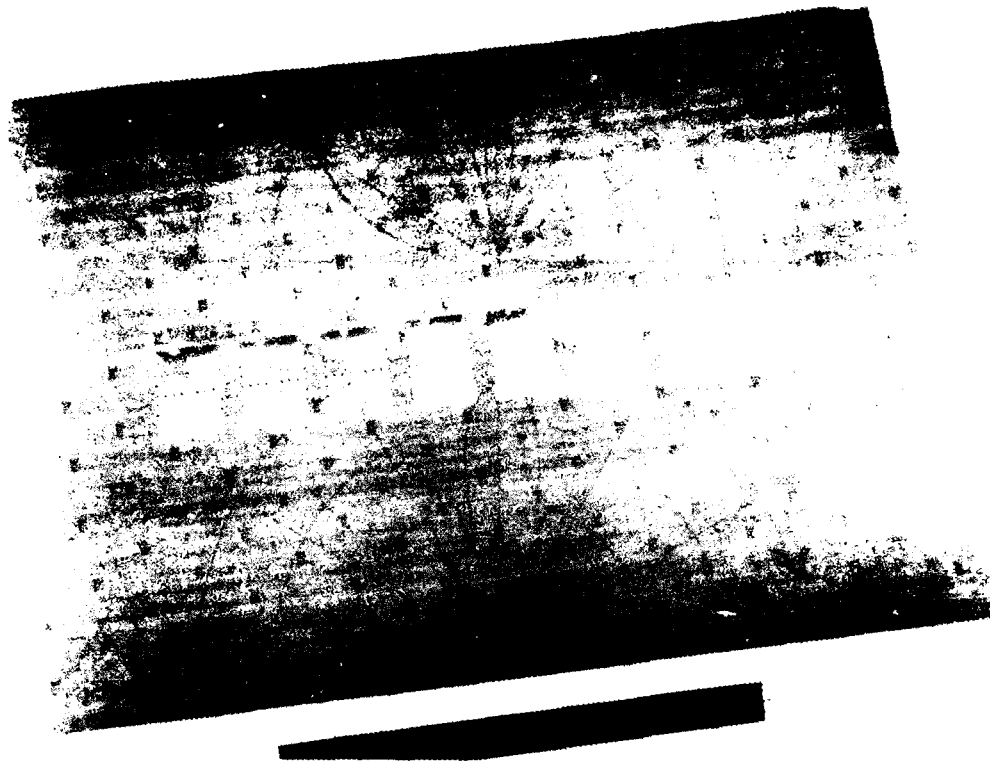

Figure 22. Prototype array of post-tuned elements for frequency-scanned applications.

The operating frequency of a rectangular microstrip antenna can be tuned over a 1.5-to-1 range without changing its size or the feed location. The tuning is accomplished by varying the number and locations of the shorting posts. The radiation patterns of the microstrip elements do not change significantly as the operating frequency is varied.

This method of tuning eliminates most of the temperature drift and bias-control problems that are encountered if varactors are used to tune the antenna's operating frequency. Also, since the frequency depends on post locations and not on variable reactances, it should be easier to ensure that all elements of an array are resonant at the same frequency.

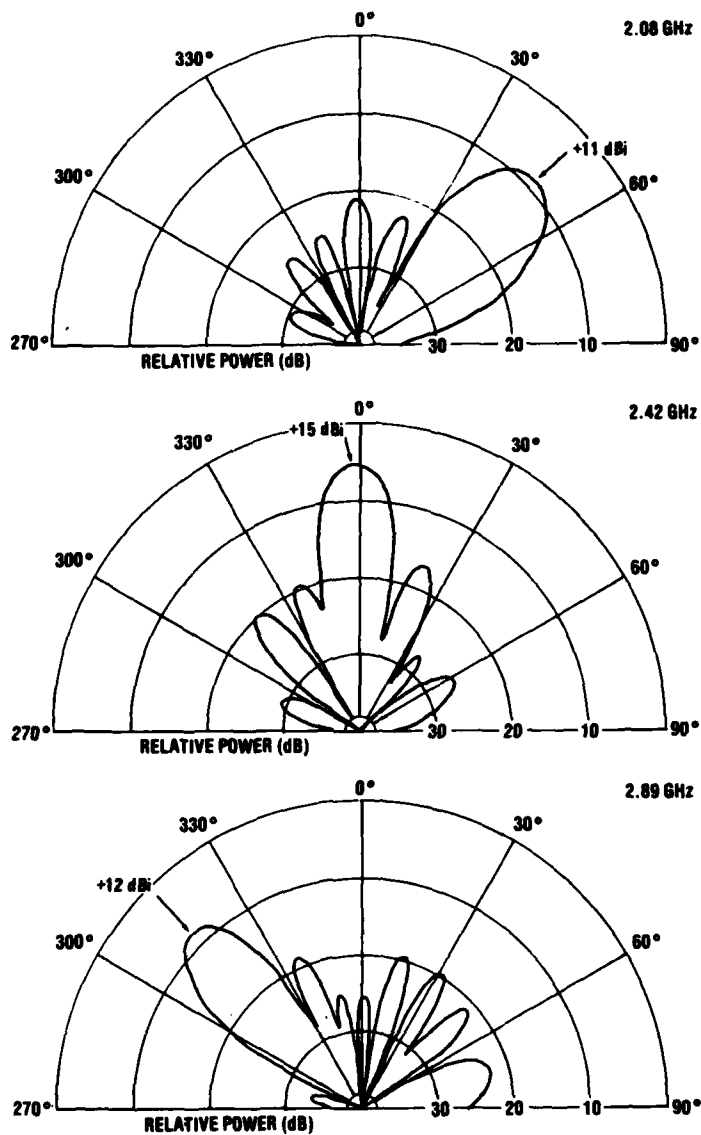

Figure 23. Typical E-plane radiation patterns of eight-element, frequency-scanned array with uniform amplitude distribution. Array gain is 11 dBi at 2.08 GHz, 15 dBi at 2.42 GHz, and 12 dBi at 2.89 GHz.

The polarization of square microstrip antennas can be varied by changing the locations of shorting posts. Very narrow bandwidth circular polarization of either sense can be obtained, as well as horizontal or vertical linear polarization. The axial ratio of the circularly polarized antenna is less than 3 dB over a wide portion of the beam. Similar results have also been obtained for circular microstrip antennas.

In addition to providing active control of the frequency and polarization of a microstrip antenna, these post-tuning techniques can ease the burdens on designing and manufacturing the antennas. The precise operating frequency and polarization can be altered by inserting shorting posts during manufacturing or prior to use in order to obtain the desired performance.

The frequency agility and polarization diversity provide added versatility to the microstrip antenna. Furthermore, these features are obtained without sacrificing the thin, conformal structure of the microstrip antenna and without increasing the complexity of the external of microwave feed network.

LITERATURE CITED

1. Carmen S. Malagisi, Electronically Scanned Microstrip Antenna Array, U.S. Patent No. 4,053,895 (11 October 1977).
2. Y. T. Lo, D. Solomon, and W. F. Richards, Theory and Experiment on Microstrip Antennas, IEEE Trans. Ant Prop AP-27 (March 1979), 137-145.
3. Anders G. Derneryd, Linearly Polarized Microstrip Antennas, IEEE Trans. Ant Prop AP-24 (November 1976), 846-851.
4. E. O. Hammerstad, Equations for Microstrip Circuit Design, Proc. 5th European Microwave Conference (September 1975), 268-272.
5. R. F. Harrington, Time-Harmonic Electromagnetic Fields, McGraw-Hill, New York (1961), 183.
6. Keith R. Carver and Edgar L. Coffey, Theoretical Investigation of the Microstrip Antenna, New Mexico State University Physical Science Laboratory, Technical Report PT-00929 (January 1979), prepared for U.S. Army Research Office Grant DAAG29-78-G-0082.
7. Daniel H. Schaubert and Frederick G. Farrar, Microstrip Antenna with Polarization Diversity, Program and Abstracts of National Radio Science Meeting USNC/URSI (November 1979), 139.

SELECTED BIBLIOGRAPHY

S. W. Bartley and D. A. Huebner, A Dual Beam Low Sidelobe Microstrip Array, IEEE AP-S International Symposium Digest (June 1979), 130-133.

John L. Kerr, Microstrip Antenna Developments, Proc. Workshop on Printed Circuit Antenna Technology, New Mexico State University (October 1979), 3-1 to 3-20.

John L. Kerr, Microstrip Polarization Techniques, Proc. 1978 Antenna Applications Symposium, University of Illinois (September 1978).

John L. Kerr, Other Microstrip Antenna Applications, Proc. 1977 Antenna Applications Symposium, University of Illinois (April 1977).

John L. Kerr, Terminated Microstrip Antenna, Proc. 1978 Antenna Applications Symposium, University of Illinois (September 1978).

Nichalos P. Kernweis and John McIlvenna, Microstrip Antenna Elements for Hemispherically Scanned Arrays, Rome Air Development Center, RADC-TR-79-43 (February 1979).

Robert E. Munson, Conformal Microstrip Antennas and Microstrip Phased Arrays, IEEE Trans. Ant Prop, AP-22, (January 1974), 74-78.

Robert E. Munson and Gary G. Sanford, Conformal Microstrip Antenna Arrays, Proc. of 1977 Antenna Applications Symposium, University of Illinois (April 1977).

L. R. Murphy, SEASAT and SIR-A Microstrip Antennas, Proc Workshop on Microstrip Antenna Technology, New Mexico State University, (October 1979), 18-1 to 18-20.

W. F. Richards, Y. T. Lo, P. Simon, and D. D. Harrison, Theory and Applications for Microstrip Antennas, Proc. Workshop on Printed Circuit Antenna Technology, New Mexico State University (October 1979), 8-1 to 8-23.

Henry D. Weinschel, A Cylindrical Array of Circularly Polarized Microstrip Antennas, IEEE AP-S International Symposium Digest (June 1975), 177-180.

James S. Yee and William J. Furlong, An Extremely Lightweight Electronically Steerable Microstrip Phased Array Antenna, IEEE AP-S International Symposium Digest (May 1978), 170-173.

DISTRIBUTION

ADMINISTRATOR
DEFENSE TECHNICAL INFORMATION CENTER
ATTN DTIC-DDA (12 COPIES)
CAMERON STATION, BUILDING 5
ALEXANDRIA, VA 22314

COMMANDER
US ARMY RSCH & STD GP (EUR)
ATTN CHIEF, PHYSICS & MATH BRANCH
FPO NEW YORK 09510

COMMANDER
US ARMY ARMAMENT MATERIEL
READINESS COMMAND
ATTN DR SAR-LEP-L, TECHNICAL LIBRARY
ROCK ISLAND, IL 61299

COMMANDER
US ARMY MISSILE & MUNITIONS
CENTER & SCHOOL
ATTN ATSK-CTD-F
REDSTONE ARSENAL, AL 35809

DIRECTOR
US ARMY MATERIEL SYSTEMS ANALYSIS
ACTIVITY
ATTN DRXSY-MP
ABERDEEN PROVING GROUND, MD 21005

DIRECTOR
US ARMY BALLISTIC RESEARCH LABORATORY
ATTN DR DAR-TSB-S (STINFO)
ABERDEEN PROVING GROUND, MD 21005

US ARMY ELECTRONICS TECHNOLOGY
AND DEVICES LABORATORY
ATTN DELET-DD
FORT MONMOUTH, NJ 07703

HQ, USAF/SAMI
WASHINGTON, DC 20330

TELEDYNE BROWN ENGINEERING
CUMMINGS RESEARCH PARK
ATTN DR. MELVIN L. PRICE, MS-44
HUNTSVILLE, AL 35807

DEPARTMENT OF COMMERCE
NATIONAL BUREAU OF STANDARDS
ATTN LIBRARY
WASHINGTON, DC 20234

INSTITUTE FOR TELECOMMUNICATIONS
SCIENCES
NATIONAL TELECOMMUNICATIONS
& INFO ADMIN
ATTN LIBRARY
BOULDER, CO 80303

DIRECTOR
DEFENSE ADVANCED RESEARCH
PROJECTS AGENCY
1400 WILSON BLVD
ATTN TARGET ACQUISITION
& ENGAGEMENT DIV
ATTN WEAPONS TECH & CONCEPTS DIV
ARLINGTON, VA 22209

DIRECTOR
DEFENSE COMMUNICATIONS AGENCY
ATTN TECH LIBRARY
WASHINGTON, DC 20305

DIRECTOR
DEFENSE INTELLIGENCE AGENCY
ATTN DT-2, WEAPONS & SYSTEMS DIV
ATTN DT-4, ELECTRONICS AND COMMAND
AND CONTROL DIV
WASHINGTON, DC 20301

DIRECTOR
NATIONAL SECURITY AGENCY
ATTN TECHNICAL LIBRARY
FORT GEORGE G. MEADE, MD 20755

NAVAL POST GRADUATE SCHOOL
CODE 62AB
ATTN RICHARD W. ADLER
MONTEREY, CA 93940

NATIONAL BUREAU OF STANDARDS
ELECTROMAGNETIC FIELDS DIVISION 723.05
ATTN RAYMOND C. BAIRD
BOULDER, CO 80302

NAVAL AIR TEST CENTER
CODE SY-81 ANTENNA/AVIONICS SECTION
ATTN DENNIS DECARLO
PATUXENT RIVER, MD 20670

NAVAL UNDERWATER SYSTEMS CENTER
ATTN CODE 342, DENNIS E. FESSENDEN
NEW LONDON, CT 06320

NAVAL RESEARCH LABORATORY
CODE 7944F
ATTN FREDERIC FINE
WASHINGTON, DC 20390

USA SATELLITE COMM AGENCY
ATTN GEORGE T. GOBEAUD
FORT MONMOUTH, NJ 07703

NAVAL SURFACE WEAPONS CENTER
DAHLGREN LABORATORY
ATTN CODE CF42, JOSEPH HALBERSTEIN
DAHLGREN, VA 22448

DISTRIBUTION (Cont'd)

NAVAL AIR DEVELOPMENT CENTER
CODE 2041
ATTN HERBERT HEFFNER
WARMINSTER, PA 18974

NAVAL OCEAN SYSTEM CENTER
ATTN JOHN M. HORN
SAN DIEGO, CA 92152

TRANSPORTATION SYSTEMS CENTER
ATTN RUDY KALAFUS
CAMBRIDGE, MA 02143

PACIFIC MISSILE TEST CENTER
CODE 1171
ATTN CYRIL M. KALOJ
PT. MUGU, CA 93042

NASA GODDARD SPACE FLIGHT CENTER
CODE 761
ATTN ABRAHAM KAMPINSKY
GREENBELT, MD 20771

BALLISTIC MISSILE DEFENSE
ADVANCE TECHNOLOGY CENTER
PO BOX 1500
ATTN BMDATC-R, FAN KING
HUNTSVILLE, AL 35807

HQ, ROME AIR DEVELOPMENT CENTER
CODE EEA
ATTN ROBERT J. MALLOUX
ATTN JOHN MCILVENNA
HANSCOM AFB, MA 01713

ROME AIR DEVELOPMENT CENTER
CODE OCTS
ATTN CARMEN S. MALAGISI
GRIFFISS AFB, NY 13441

US ARMY RESEARCH OFFICE
P.O. BOX 12211
ATTN JAMES MINK, CODE DRXRO-EL
RESEARCH TRIANGLE PARK, NC 27709

US ARMY FOREIGN SCIENCE AND
TECHNOLOGY CENTER
220 7TH ST., NE
ATTN JAMES P. MURO, DRXST-ES-3
CHARLOTTESVILLE, VA 22901

FEDERAL AVIATION AGENCY
800 INDEPENDENCE AVENUE
ATTN MARTIN NATCHIPOLSKY
WASHINGTON, DC 20590

US INFORMATION AGENCY
CODE IBS/ET
ATTN JULIUS ROSS
WASHINGTON, DC 20547

NAVAL WEAPONS CENTER
ATTN GAYLON E. RYNO
ATTN JOHN A. DOWNS, CODE 3556
CHINA LAKE, CA 93555

US ARMY CORADCOM
ATTN DRDCO-COM-RM-4
FELIX SCHWERING
FORT MONMOUTH, NJ 07703

AF AVIONICS LABORATORY
ATTN AFAL/TEM, JOHN P. SHANKLIN, JR
WRIGHT-PATTERSON AFB, OH 45433

NAVAL RESEARCH LABORATORY
ATTN CODE 5733, BORIS SHELEG
WASHINGTON, DC 20375

NAVAL WEAPONS SUPPORT CENTER
CODE 3021
ATTN JOSEPH M. SMIDDIE
CRANE, IN 47522

NATIONAL SECURITY AGENCY
CODE 3083
ATTN A. A. STREJECK
FORT GEORGE G. MEADE, MD 20755

US ARMY ELECTRONICS RESEARCH
& DEVELOPMENT COMMAND
ATTN TECHNICAL DIRECTOR, DRDEL-CT

HARRY DIAMOND LABORATORIES
ATTN CO/TD/TSO/DIVISION DIRECTORS
ATTN RECORD COPY, 81200
ATTN HDL LIBRARY, 81100 (3 COPIES)
ATTN HDL LIBRARY, 81100 (WOODBRIDGE)
ATTN TECHNICAL REPORTS BRANCH, 81300
ATTN CHAIRMAN, EDITORIAL COMMITTEE
ATTN LEGAL OFFICE, 97000
ATTN CHIEF, 13000
ATTN LANHAM, C. E., 00213
ATTN ISLER, W. E., 13500
ATTN CHIEF, 11100
ATTN CHIEF, 11200
ATTN CHIEF, 11400
ATTN FARRAR, F., 11200 (20 COPIES)
ATTN HAYES, S. T., 11200 (10 COPIES)
ATTN SINDORIS, A. R., 11200 (45 COPIES)

