

AD-A098 917

AERONAUTICAL RESEARCH LABS MELBOURNE (AUSTRALIA)
GROUND STATION DIGITAL INTERFACE SYSTEM DETAIL.(U)

F/6 9/5

UNCLASSIFIED

SEP 80 U R KRIESER
ARL/MECH-ENG-TM-403

NL

1 0 1

4 2

0 0 0 0

END

DATE

FILED

6-81

DTIC

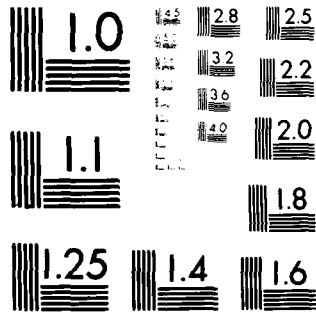

MICROCOPY RESOLUTION TEST CHART
NATIONAL BUREAU OF STANDARDS-1963-A

UNCLASSIFIED

12
BS

ARL-MECH-ENG-
TECH-MEMO-403

AR-002-228



THE UNITED STATES NATIONAL
TECHNICAL INFORMATION SERVICE
IS AUTHORISED TO
REPRODUCE AND SELL THIS REPORT

DEPARTMENT OF DEFENCE

DEFENCE SCIENCE AND TECHNOLOGY ORGANISATION

AERONAUTICAL RESEARCH LABORATORIES

MELBOURNE, VICTORIA

MECHANICAL ENGINEERING TECHNICAL MEMORANDUM 403

GROUND STATION DIGITAL INTERFACE SYSTEM DETAIL

U.R. KRIESER

DTIC
SELECTED
MAY 14 1981
A

Approved for Public Release.



© COMMONWEALTH OF AUSTRALIA 1980

SEPTEMBER 1980

DTIC FILE COPY

COPY No 18

81 5 14 037

UNCLASSIFIED

AD A098917

DEPARTMENT OF DEFENCE
DEFENCE SCIENCE AND TECHNOLOGY ORGANISATION
AERONAUTICAL RESEARCH LABORATORIES

(14) ARL/MECH-ENG-TM-403

(9) Mechanical Engineering Technical Memorandum 403

(6) GROUND STATION DIGITAL INTERFACE SYSTEM DETAIL.

(10) U.R./KRIESER

(11) Sep 80

(12) 90

SUMMARY

Digital computer interface equipment has been developed to allow the recovery of digital data encoded in special format and recorded both in flight and in laboratory experiments using an analogue tape transport.

Circuit techniques adopted for the interface equipment are discussed in a separate report. Complete system details required for circuit manufacture, operation and in-service maintenance are provided in the present publication.

POSTAL ADDRESS: Chief Superintendent, Aeronautical Research Laboratories,
P.O. Box 4331, Melbourne, Victoria, 3001, Australia.

008650 *Das*

DOCUMENT CONTROL DATA SHEET

Security classification of this page: UNCLASSIFIED

- | | |
|--|--|
| 1. DOCUMENT NUMBERS | 2. SECURITY CLASSIFICATION |
| a. AR Number:
AR-002-228 | a. Complete document:
UNCLASSIFIED |
| b. Document Series and Number:
Mechanical Engineering
Technical Memorandum 403 | b. Title in isolation:
UNCLASSIFIED |
| c. Report Number:
ARL-MECH-ENG-TECH-MEMO-403 | c. Summary in isolation:
UNCLASSIFIED |
| 3. TITLE: | |

GROUND STATION DIGITAL INTERFACE SYSTEM DETAIL

- | | |
|--|---|
| 4. PERSONAL AUTHOR:

KRIESER, U.R. | 5. DOCUMENT DATE:
September, 1960 |
| 7. CORPORATE AUTHOR(S):
Aeronautical Research
Laboratories | 6. TYPE OF REPORT AND
PERIOD COVERED: |
| 9. COST CODE:
445980 | 8. REFERENCE NUMBERS
a. Task:
DST 20/26
b. Sponsoring Agency:
DST |
| 10. IMPRINT:
Aeronautical Research
Laboratories, Melbourne | 11. COMPUTER PROGRAM(S)
(Title(s) and language(s)): |
| 12. RELEASE LIMITATIONS (of the document): | |

Approved for Public Release.

12.0. OVERSEAS:	N.O.		P.R.	1	A		B		C		D		E
-----------------	------	--	------	---	---	--	---	--	---	--	---	--	---

13. ANNOUNCEMENT LIMITATIONS (of the information on this page):
No limitation.

- | | |
|---|---------------------------|
| 14. DESCRIPTORS:
Digital computers. Analog to
Data converters. digital converters.
Interfaces. | 15. COSATI CODES:
0902 |
|---|---------------------------|

16. ABSTRACT:
Digital computer interface equipment has been developed to allow the recovery of digital data encoded in special format and recorded both in flight and in laboratory experiments using an analogue tape transport.

Circuit techniques adopted for the interface equipment are discussed in a separate report. Complete system details required for circuit manufacture, operation and in-service maintenance are provided in the present publication.

Requested For	<input checked="" type="checkbox"/>	<input type="checkbox"/>	<input type="checkbox"/>
THIS GRAAL			
THIS TAB			
Announced			
Classification			
Classification/			
Reliability Codes			
AVAIL and/or			
Special			

CONTENTS

	<u>PAGE NO.</u>
1. INTRODUCTION	1
2. CIRCUIT DETAILS	1
3. OPERATING INSTRUCTIONS	2
4. INTERWIRING DETAILS	5
4.1 Power Distribution	8
4.2 Wiring to Front Panel Mounted Components (Excluding Connectors)	10
4.3 Wiring to Front Panel and Rear Panel Mounted Connectors	10
4.4 Wiring to Printed Circuit Card Edge Connectors	19
5. COMPONENT IDENTIFICATION	32
6. INTEGRATED CIRCUIT WIRING DETAILS	34
7. COMPONENT LISTS	38
7.1 Components for AC to DC Converter	39
7.2 Components for Voltage Regulators	40
7.3 Components for Output Buffers	42
7.4 Components for Input Clock Signal Generator	43
7.5 Components for Electronic Flywheel	44
7.6 Components for Control Signal Generator for Serial System	46
7.7 Components for Control Signal Generator for Parallel System	47
7.8 Components for Serial to Parallel Converter for Serial System	48
7.9 Components for Serial to Parallel Converter for Parallel System	49
7.10 Components for Time of Day Store and Preset Stop Generator	50
7.11 Components for Selected Data and Fixed Data Store	51
7.12 Components for Computer Interrupt Controller	52
7.13 Components for Front and Rear Panels and Chassis	53
8. OUTPUT BUFFER CONNECTION DETAILS	55
REFERENCES	
FIGURES	
DISTRIBUTION	

1. INTRODUCTION

Ground station equipment to recover and process data recorded both in flight and in laboratory experiments using special digital encoding techniques comprises an analogue magnetic tape reproducing machine, a digital computer with suitable peripherals and a special interface (which is the subject of this document) between the tape reproducer and the computer.

An associated report¹ details the requirements and the circuit techniques used to meet those requirements. The information herein is intended to complement that provided in the report. Complete system details required for the operation and maintenance of the interface equipment are included.

2. CIRCUIT DETAILS

The various functions performed by the digital interface are indicated in the block schema of Fig. 1.

The digital interface is housed in a standard 48.3 cm wide by 17.8 cm high rack. Front and rear view photographs of the instrument are given in Figs. 2 and 3.

All circuits except those associated with the front and rear panels, and the power supply, are mounted on plug-in printed circuits. In the following table the various circuits incorporated in the interface are listed. Board serial numbers and printed circuit card slot reference numbers are also indicated in the table. The chassis has been wired to accept 12 plug-in cards of which nine are required at present (as indicated in the table), thus three spare slots are available for future circuit expansion if required.

CARD SLOT NUMBER	FUNCTION	SERIAL NUMBER	RELEVANT FIGURES
Not plug-in	AC to DC Converter	FL-01-07-01	4,5
0	Voltage Regulators	FL-01-07-02	6,7
1	Output Buffers	FL-01-07-03	8,9
2	Input Clock Signal Generator	FL-01-07-04	10,11
3	Electronic Flywheel	FL-01-07-05	12,13
4	Control Signal Generator for Serial System	FL-01-07-06	14,15
4	Control Signal Generator for Parallel System	FL-01-07-10	16,17
5	Serial to Parallel Converter for Serial System	FL-01-07-07	18,19
5	Serial to Parallel Converter for Parallel System	FL-01-07-11	20,21
6	Time-of-Day Store and Preset Stop Generator	FL-01-07-08	22,23
7	Selected Data and Fixed Data Store	FL-01-07-09	24,25
8	Computer Interrupt Controller	FL-01-07-12	26,27

The function and theory of operation of each circuit are detailed in the associated report¹. Circuit connections and component layout details for each printed circuit listed in the above table are given in the corresponding figures referred to in the table.

Information on the system of component identification used is given in Sec. 5. In the case of circuits containing digital integrated plug-in devices, logic type symbols are used and most of the integrated circuit pin numbers are also marked. Integrated circuit wiring details given in Sec. 6 include supply connections not marked on the logic circuits. Component lists are given in Sec. 7 and interwiring details for printed circuits and panel mounted components are given in Sec. 4.

Circuit details for the numeric indicators and the preset stop generator are given respectively in Fig. 28a and Fig. 28b. Connections to the front panel components are given in Fig. 29.

Inputs to the output buffers may be transferred to the outputs without inversion if links A (Fig. 8) are inserted, or inverted if links B are inserted instead. The present link connections together with output connection details are given in Sec. 8.

3. OPERATING INSTRUCTIONS

Nominal 240 volt 50 hertz single phase power is coupled to the interface via connector J110 mounted on the rear panel. Mains earth and chassis are connected to the green GND terminal on the rear panel. The circuit common is internally isolated from chassis and is connected to the black COM terminal on the rear panel. A shorting link allows for optional connection of circuit common to ground.

Two NRZ digital input lines are coupled to the INPUT connector J101 on the front panel or to J111 on the rear panel when the serial system of encoding is used. When the parallel system is used the number of NRZ digital input lines is increased to seven but connection is still via J101 or J111. The input signals are usually derived from digital reproducing amplifiers² which plug directly into the electronics tray of the analogue magnetic tape reproducing machine. For checkout purposes, input signals for use only when the serial system of encoding is adopted, may be derived from the serial digital data generator³.

The tape machine preset stop signal (Sec. 8) is coupled to the remote control unit⁴ via OUTPUT 1 connector J102 on the front panel, or J112 on the rear panel. These outputs are logically identical but are buffered separately.

Digital computer inputs/outputs are taken to connectors J103 and J113 on front and rear panels respectively. One parity checkbit line, at present un-used, is also taken to these connectors. Additional outputs comprising an FM CLK, a 4-FRAME SYNC and time synchronizing signals at 2-second, 20-second and 2-minute repetition period are also coupled to J103 and J113. These latter outputs are taken to an analogue demultiplexer, an external item of hardware specially developed to allow multiplexed analogue data to be demultiplexed. The outputs taken respectively to J103 and J113 are logically equivalent but are buffered separately.

Toggle switch S1 (Fig. 29) mounted on the front panel connects power to the interface circuits and causes neon indicator LP1 to glow.

To guard against overvoltage on the V_{CC} (+5 volt nominal) regulated output voltage line a trip circuit is incorporated. Occasionally the trip circuit may be actuated if a short interruption of mains power occurs. In such an instance the V_{CC} output would drop to zero rendering the interface inoperative. Mains power would still be indicated via neon indicator LP1. If it is suspected that the overload circuit has been tripped, the absence of the normal V_{CC} voltage can be most readily checked by switching the tape machine preset stop switch S2 on. If 5V is present on the V_{CC} line filament lamp LP2 will glow accordingly. Restoration of the V_{CC} supply to normal after the overload has tripped can only be achieved by switching off power to the interface for a short period via the power switch S1.

If the tape machine preset stop function is not required toggle switch S2 (Fig. 29) should be left off. If the stop function is required, the following operations should be performed in the sequence indicated, before the tape is set in motion:

- (1) The required stop time should be preset via thumbwheel switches S4A to S4H (Fig. 28b) which plug into P161 to P168 (Fig. 29).
- (2) Start pushbutton S3 should be momentarily depressed.
- (3) Toggle switch S2 should be switched on.

A total of 20 numeric indicators, arranged in three horizontal rows on the front panel (Fig. 29), are used.

Fixed data comprising run number information (four indicators), month information (two indicators) and day information (two indicators) may be displayed in decimal form via the top row of

indicators. These indicators may be switched off by the toggle switch S6 (to the right of the display) via which anode voltage is coupled to the indicator tubes.

Time-of-day data comprising hour information (two indicators), minute information (two indicators) and day information (two indicators) may be displayed in decimal form via the middle row of indicators. These indicators may be switched off by the toggle switch S7.

Decimal thumbwheel switches S5A and S5B (each single pole 10-position types (Fig. 29)) enable any selected word in a data frame to be displayed via the bottom row of indicators. These displays are in octal form (digits 0 through 7 only) and are labelled "magnitude" (four indicators) and "multiplier" (two indicators) in agreement with data encoded via the auto-ranging analogue to digital converter included in the airborne data logging equipment⁵. These indicators may be switched off by the toggle switch S8.

Defining b_0, b_1 etc. as the digital information (either a "one" or a "zero") contained in each data bit the following table is readily drawn to indicate the configuration used for the selected data display.

Magnitude				Multiplier	
$b_4b_5b_6$	$b_7b_8b_9$	$b_{10}b_{11}b_{12}$	$b_{13}b_{14}b_{15}$	b_0	$b_1b_2b_3$

Selection of the fixed data and time-of-day word or of words describing the outputs of digital transducers⁷ is quite valid for the selected data display but the "magnitude" and "multiplier" designations are not then relevant.

Parity lamps LP3 and LP4 (Fig. 29) glow if a lateral parity error (for either serial or parallel systems of encoding) or a longitudinal parity error (serial system only) respectively is detected for the selected word. Since these lamps will glow only for the duration of data frames, for which a parity error is detected in the selected word, occasional errors would be difficult to observe for data which is read from airborne recordings.

Operational checking of the interface is performed with the aid of the serial digital data generator³ which provides signals of standard word composition. Word compositions with parity errors may be generated with this latter equipment thus enabling the parity circuits in the interface to be checked. In such cases the parity

lamp(s) should glow continuously while words with parity errors are being received by the interface.

4. INTERWIRING DETAILS

Details of all interwiring connections within the interface are included (or referred to) in this section.

A summary of the interface connectors together with their application is given in the following table. Details on the types of connectors and switches (referred to in this section) are given in Sec. 7.13.

CONNECTOR	LOCATION	APPLICATION
J101	Front Panel	Digital signal input connector
J102	Front Panel	Tape machine preset stop output (OUTPUT 1) connector
J103	Front Panel	Digital computer output (OUTPUT 2) connector
J110	Rear Panel	Mains input connector
J111	Rear Panel	Digital signal input connector
J112	Rear Panel	Tape machine preset stop output (OUTPUT 1) connector
J113	Rear Panel	Digital computer output (OUTPUT 2) connector
J120	Internal sub-chassis	Board 0 (Voltage Regulators) edge connector
J121	Internal sub-chassis	Board 1 (Output Buffers) edge connector
J122	Internal sub-chassis	Board 2 (Input Clock Signal Generator) edge connector
J123	Internal sub-chassis	Board 3 (Electronic Flywheel) edge connector
J124	Internal sub-chassis	Board 4 (Control Signal Generator) edge connector
J125	Internal sub-chassis	Board 5 (Serial to Parallel Converter) edge connector
J126	Internal sub-chassis	Board 6 (Time-of-Day Store and Preset Stop Generator) edge connector
J127	Internal sub-chassis	Board 7 (Selected Data and Fixed Data Store) edge connector
J128	Internal sub-chassis	Spare board edge connector
J129	Internal sub-chassis	Spare board edge connector
J130	Internal sub-chassis	Spare board edge connector
J131	Internal sub-chassis	Spare board edge connector
J132	Internal sub-chassis	AC to DC Converter connector
P132	AC to DC Converter power unit	Cable connector mating with J132

CONNECTOR	LOCATION	APPLICATION
J133	Numeric indicator sub-chassis	Parity lamp input
P133	Internal cable loom	Cable connector mating with J133
P140-P160	Internal cable looms	Cable mounted valve sockets mating with numeric indicator units
P161-P170	Internal cable looms	Cable mounted sockets mating with front panel mounted thumbwheel switches.

4.1 Power Distribution

Input power is derived from 240V 50Hz single phase AC mains via rear panel connector J110 wired as indicated in the following table.

J110 WIRING

PIN	CONNECTED TO	SIGNAL DESCRIPTION
L	Fuse F1 (Front Panel - Fig. 29)	Active
N	S1-3 (Front panel - Fig. 29)	Neutral
E	TM1 (Green terminal on rear panel - also connected to chassis).	Earth

The switched mains power input and unregulated DC outputs are wired to connector J132. Wiring information for J132 is given in the following table.

PIN	CONNECTED TO	SIGNAL DESCRIPTION
1a	J120-35a	Unregulated input (V_A) for +15V Supply
2a	J120-38a	Analog common input
3a	J120-37a	Unregulated input (V_B) for -15V Supply
4a	TB1 (terminal block - Fig. 29)	Numeric indicator Supply common
5a	S6-2, S7-2, S8-2	Numeric indicator supply (V_D)
6a	S6-1	Switched supply for top row of numeric indicators
7a	S7-1	Switched supply for middle row of numeric indicators
8a	S8-1	Switched supply for bottom row of numeric indicators
1b	J120-21a&b, J120-22a&b	Unregulated input (V_C) for +5V supply
2b	J120-6a	Reference voltage input for +5V supply
3b	J120-18a&b, J120 19a&b	Digital common input
4b	S1-2	Switched mains neutral
5b	S1-5	Switched mains active

Regulated voltage outputs are taken from the printed circuit edge connector J120. Power is transferred to the interface circuits via J120 for which wiring details are given in the following table. Only the main heavy current connections are indicated. Separate lines for each connection point indicated in the following table are not coupled back to J120; heavy duty lines are sequentially coupled from one printed circuit edge connector to the next. Further (low current) connections are indicated elsewhere in this section.

J120 WIRING (HEAVY CURRENT LINES ONLY)

PINS	CONNECTED TO	SIGNAL DESCRIPTION
9a&b, 10a&b, 11a&b	J121-10a&b, J122-10a&b, J123-10a&b J124-10a&b, J125-10a&b, J126-10a&b J127-10a&b, J128-10a&b, J129-10a&b J130-10a&b, J131-10a&b.	+5V OUTPUT (V_{CC})
1a&b, 2a&b, 3a&b	J121-1a&b, J121-50a&b, J122-1a&b J122-50a&b, J123-1a&b, J123-50a&b J124-1a&b, J124-50a&b, J125-1a&b J125-50a&b, J126-1a&b, J126-50a&b J127-1a&b, J127-50a&b, J128-1a&b J128-50a&b, J129-1a&b, J129-50a&b J130-1a&b, J130-50a&b, J131-1a&b J131-50a&b.	DIGITAL COMMON
44a&b	J121-44a&b, J122-44a&b, J123-44a&b J124-44a&b, J125-44a&b, J126-44a&b J127-44a&b, J128-44a&b J129-44a&b, J130-44a&b, J131-44a&b.	+15V OUTPUT (V_{AA})
46a&b	J121-46a&b, J122-46a&b J123-46a&b, J124-46a&b J125-46a&b, J126-46b J127-46a&b, J128-46a&b J129-46a&b, J130-46a&b J131-46a&b.	ANALOG COMMON
48a&b	J121-48a&b, J122-48a&b J123-48a&b, J124-48a&b J125-48a&b, J126-48a&b J127-48a&b, J128-48a&b J129-48a&b, J130-48a&b J131-48a&b	-15V OUTPUT (V_{BB})

4.2 Wiring to Front Panel Mounted Components (Excluding Connectors)

Circuit information and interwiring details for front panel mounted components are given in Figs. 28 and 29. Cable mounted valve sockets P141 to P160 (Figs. 28a and 29) plug into the numeric indicator units IU1 to IU20 (Fig. 28a). Cable mounted printed circuit edge connectors P161 to P168 (Figs. 28b and 29) plug into the preset stop switch units SU1 to SU8 (Fig. 28b).

4.3 Wiring to Front and to Rear Panel Mounted Connectors

Lists of wiring connections to the front panel mounted connectors J101 to J103 and to the rear panel mounted connectors J111 to J113 are included here together with descriptive information for the inputs and the outputs. Wiring details for rear panel mounted mains power input connector J110 have been given in Sec. 4.1.

(a) WIRING TO J101 (DIGITAL SIGNAL INPUT AT FRONT PANEL)

PIN	CONNECTED TO	SIGNAL DESCRIPTION
A	J122-8a	NRZ1 input
B	J122-8b	Common for NRZ1 input
C	J122-4a	NRZ3 input
D	J122-4b	Common for NRZ3 input
E		
F		
G	J122-2a	NRZ2 input
H	J122-2b	Common for NRZ2 input
J	J122-3a	NRZ4 input
K	J122-3b	Common for NRZ4 input
L		
M		
N	J122-7b	Common for NRZ5 input
P	J122-5a	NRZ6 input
R	J122-5b	Common for NRZ6 input
S	J122-6a	NRZ7 input
T	J122-6b	Common for NRZ7 input
U	J122-7a	NRZ5 input
V		

(b) WIRING TO J102 (TAPE MACHINE PRESET STOP OUTPUT (OUTPUT 1)
AT FRONT PANEL)

PIN	CONNECTED TO	SIGNAL DESCRIPTION
A	J121-6a	Output q5F
B	J121-10a	V _{CC}
C	*Common bus	Common q5F and q8F
D	J121-5a	Output q8F
E	Common bus	Common q7F
F	J121-3a	Output q7F

* Common bus connected between J121-1a and J121-50a.

Signal lines and associated common lines are wired using co-axial cable.

(c) WIRING TO J103 (DIGITAL COMPUTER OUTPUT (OUTPUT 2) AT FRONT PANEL)

PIN	CONNECTED TO	SIGNAL DESCRIPTION
1	J121-49a	Output q2F
2	J121-45a	Output q1F
3	J121-43a	Output q4F
4	J121-41a	Output q3F
5	J121-40a	Output q10F
6	J121-38a	Output q9F
7	J121-37a	Output q12F
8	J121-35a	Output q11F
9	J121-34a	Output q18F
10	J121-32a	Output q17F
11	J121-31a	Output q20F
12	J121-29a	Output q19F
13	J121-27b	Input q24
14	J121-25a	Output q23F
15	J121-24a	Output q26F
16	J121-22a	Output q25F
17	J121-21a	Output q28F
18	*Common bus	Common q2F
19	Common bus	Common q1F
20	Common bus	Common q4F
21	Common bus	Common q3F
22	Common bus	Common q10F
23	Common bus	Common q9F
24	Common bus	Common q12F
25	Common bus	Common q11F
26	Common bus	Common q18F
27	Common bus	Common q17F
28	Common bus	Common q20F
29	Common bus	Common q19F
30	Common bus	Common q24F
31	Common bus	Common q23F
32	Common bus	Common q26F
33	Common bus	Common q25F
34	Common bus	Common q27F
35	J121-19a	Output q27F
36	Common bus	Common q22F
37	J121-18a	Output q22F
38	Common bus	Common q21F
39	J121-16a	Output q21F
40	Common bus	Common q14F
41	J121-15a	Output q14F
42	Common bus	Common q13F

PIN	CONNECTED TO	SIGNAL DESCRIPTION
43	J121-13a	Output q13F
44	Common bus	Common q16F
45	J121-12a	Output q16F
46	Common bus	Common q15F
47	J121-9a	Output q15F
48	Common bus	Common q6F
49	J121-8a	Output q6F
50	Common bus	Common q28F

* Common bus connected between J121-1a and J121-50a.

Signal lines and associated common lines are wired using co-axial cable.

(d) WIRING TO J111 (DIGITAL SIGNAL INPUT AT REAR PANEL)

PIN	CONNECTED TO	SIGNAL DESCRIPTION
A	J122-40a	NRZ1 input
B	J122-40b	Common for NRZ1 input
C	J122-45a	NRZ3 input
D	J122-45b	Common for NRZ3 input
E		
F		
G	J122-49a	NRZ2 input
H	J122-49b	Common for NRZ2 input
J	J122-47a	NRZ4 input
K	J122-47b	Common for NRZ4 input
L		
M		
N	J122-41b	Common for NRZ5 input
P	J122-43a	NRZ6 input
R	J122-43b	Common for NRZ6 input
S	J122-42a	NRZ7 input
T	J122-42b	Common for NRZ7 input
U	J122-41a	NRZ5 input
V		

(e) WIRING TO J112 (TAPE MACHINE PRESET STOP OUTPUT (OUTPUT 1)
AT REAR PANEL)

PIN	CONNECTED TO	SIGNAL DESCRIPTION
A	J121-6b	Output q5R
B	J121-10b	V _{CC}
C	*Common bus	Common q5R and q8R
D	J121-5b	Output q8R
E	Common bus	Common q7R
F	J121-3b	Output q7R

* Common bus connected between J121-1b and J121-50b

(f) WIRING TO J113 (DIGITAL COMPUTER OUTPUT (OUTPUT 2) AT REAR PANEL)

PIN	CONNECTED TO	SIGNAL DESCRIPTION
1	J121-49b	Output q2R
2	J121-45b	Output q1R
3	J121-43b	Output q4R
4	J121-41b	Output q3R
5	J121-40b	Output q10R
6	J121-38b	Output q9R
7	J121-37b	Output q12R
8	J121-35b	Output q11R
9	J121-34b	Output q18R
10	J121-32b	Output q17R
11	J121-31b	Output q20R
12	J121-29b	Output q19R
13	J121-27b	Input q24
14	J121-25b	Output q23R
15	J121-24b	Output q26R
16	J121-22b	Output q25R
17	J121-21b	Output q28R
18	*Common bus	Common q2R
19	Common bus	Common q1R
20	Common bus	Common q4R
21	Common bus	Common q3R
22	Common bus	Common q10R
23	Common bus	Common q9R
24	Common bus	Common q12R
25	Common bus	Common q11R
26	Common bus	Common q18R
27	Common bus	Common q17R
28	Common bus	Common q20R
29	Common bus	Common q19R
30	Common bus	Common q24R
31	Common bus	Common q23R
32	Common bus	Common q26R
33	Common bus	Common q25R
34	Common bus	Common q27R
35	J121-19b	Output q27R
36	Common bus	Common q22R
37	J121-18b	Output q22R
38	Common bus	Common q21R
39	J121-16b	Output q21R
40	Common bus	Common q14R
41	J121-15b	Output q14R
42	Common bus	Common q13R

PIN	CONNECTED TO	SIGNAL DESCRIPTION
43	J121-13b	Output q13R
44	Common bus	Common q16R
45	J121-12b	Output q16R
46	Common bus	Common q15R
47	J121-9b	Output q15R
48	Common bus	Common q6R
49	J121-8b	Output q6R
50	Common bus	Common q28R

* Common bus connected between J121-1b and J121-50b.

Signal lines and associated common lines are wired using co-axial cable.

4.4 Wiring to Printed Circuit Card Edge Connectors

Lists of all wiring connections to the printed circuit card edge connectors J120 to J131 are included, but in these cases descriptive information for the inputs and the outputs is not added.

Power supply wiring only is taken to J129, J130 and J131 (only nine of the available twelve card spaces used at this time). These are available for future expansion if required.

Connector pins which engage with printed circuit card edge tracks on the component side are given an "a" identification and those on the other side are given a "b" identification.

(a) WIRING TO J120
BOARD 0 (VOLTAGE REGULATORS) EDGE
CONNECTOR

PIN NO.	CONNECTED TO	PIN NO.	CONNECTED TO
1a	J120-2a, J120-1b	1b	J120-1a, J120-2b, J121-1a
2a	J120-1a, J120-3a	2b	J120-1b, J120-3b
3a	J120-2a, J120-3b	3b	J120-2b, J120-3b
4a		4b	
5a		5b	
6a	J120-6b	6b	J132-2b, J120-6a
7a		7b	
8a		8b	
9a	J120-10a, J120-9b	9b	J120-9a, J120-10b
10a	J120-9a, J120-11a	10b	J120-9b, J120-11b, J121-10a
11a	J120-10a, J120-11b	11b	J120-10b, J120-11a
12a		12b	
13a		13b	
14a		14b	
15a		15b	
16a		16b	
17a		17b	
18a	J132-3b, J120-19a, J120-18b	18b	J120-18a, J120-19b
19a	J120-18a, J120-19b	19b	J120-19a, J120-18b
20a	J120-20b	20b	J124-10a, J120-20a
21a	J132-1b, J120-22a, J120-21b	21b	J120-21a, J120-22b
22a	J120-21a, J120-22b	22b	J120-22a, J120-21b
23a	J120-23b, J120-24a	23b	
24a	J120-24b, J120-23a	24b	
25a		25b	
26a		26b	
27a	J120-27b, J120-28a	27b	J120-27a
28a	J120-28b, J120-27a	28b	J120-28a
29a	J120-29b, J120-30a	29b	J120-29a
30a	J120-30b, J120-29a	30b	J120-30a
31a		31b	
32a		32b	
33a		33b	
34a		34b	
35a	J120-35b	35b	J132-1a, J120-35a
36a		36b	
37a	J120-37b	37b	J132-3a, J120-37a
38a	J120-38b	38b	J132-2a, J120-38a
39a		39b	
40a		40b	
41a		41b	
42a		42b	
43a		43b	
44a	J120-44b	44b	J120-44a, J121-44a
45a		45b	
46a	J120-46b	46b	J120-46a, J121-46a
47a		47b	
48a	J120-48b	48b	J120-48a, J121-48a
49a		49b	
50a		50b	

(b) WIRING TO J121
BOARD 1 (OUTPUT BUFFERS) EDGE
CONNECTOR

PIN NO.	CONNECTED TO	PIN NO.	CONNECTED TO
1a	J120-1b, J121-1b, J121-50a	1b	J121-1a, J122-1a, J121-50b
2a		2b	
3a	J102-F	3b	J112-F
4a		4b	
5a	J102-D	5b	J112-D
6a	J102-A	6b	J112-A
7a	J126-4a	7b	J125-5b
8a	J103-49	8b	J113-49
9a	J103-47	9b	J113-47
10a	J120-10b, J121-10b, J102-B	10b	J121-10a, J122-10a, J112-B
11a	J125-6b	11b	J125-7b
12a	J103-45	12b	J113-45
13a	J103-43	13b	J113-43
14a	J125-8b	14b	J125-13b
15a	J103-41	15b	J113-41
16a	J103-39	16b	J113-39
17a	J125-14b	17b	J125-15b
18a	J103-37	18b	J113-37
19a	J103-35	19b	J113-35
20a	J125-16b	20b	J125-19b
21a	J103-17	21b	J113-17
22a	J103-16	22b	J113-16
23a	J125-20b	23b	J125-21b
24a	J103-15	24b	J113-15
25a	J103-14	25b	J113-14
26a		26b	
27a	J125-22b	27b	J103-13, J113-13
28a		28b	J128-28b
29a	J103-12	29b	J113-12
30a	J125-18b	30b	J126-18b
31a	J103-11	31b	J113-11
32a	J103-10	32b	J113-10
33a	J128-47b	33b	J126-34b
34a	J103-9	34b	J113-9
35a	J103-8	35b	J113-8
36a	J125-37b	36b	J125-36b
37a	J103-7	37b	J113-7
38a	J103-6	38b	J113-6
39a	J125-38b	39b	J125-39b
40a	J103-5	40b	J113-5
41a	J103-4	41b	J113-4
42a	J126-39b	42b	J128-20b
43a	J103-3	43b	J113-3
44a	J120-44b, J121-44b	44b	J121-44a, J122-44a
45a	J103-2	45b	J113-2
46a	J120-46b, J121-46b	46b	J121-46a, J122-46a
47a	J124-42b	47b	J128-45b
48a	J120-48b, J121-48b	48b	J121-48a, J122-48a
49a	J103-1	49b	J113-1
50a	J121-50b, J121-1a	50b	J121-50a, J122-50a, J121-1b

(c) WIRING TO J122
 BOARD 2 (INPUT CLOCK SIGNAL GENERATOR)
 EDGE CONNECTOR

PIN NO.	CONNECTED TO	PIN NO.	CONNECTED TO
1a	J121-1b, J122-1b	1b	J122-1a, J123-1a
2a	J101-G	2b	J101-H
3a	J101-J	3b	J101-K
4a	J101-C	4b	J101-D
5a	J101-P	5b	J101-R
6a	J101-S	6b	J101-T
7a	J101-U	7b	J101-N
8a	J101-A	8b	J101-B
9a		9b	
10a	J121-10b, J122-10b	10b	J122-10a, J123-10a
11a		11b	
12a		12b	
13a		13b	
14a		14b	
15a		15b	
16a	J125-41b	16b	
17a	J125-43b	17b	
18a		18b	
19a	J125-5a	19b	
20a		20b	
21a	J125-4a	21b	
22a		22b	
23a	J125-6a	23b	
24a		24b	
25a		25b	
26a		26b	
27a	J123-17b	27b	
28a		28b	
29a		29b	
30a	J125-7a	30b	
31a		31b	
32a	J125-3a	32b	
33a		33b	
34a		34b	
35a		35b	
36a		36b	
37a		37b	
38a		38b	
39a		39b	
40a	J111-A	40b	J111-B
41a	J111-U	41b	J111-N
42a	J111-S	42b	J111-T
43a	J111-P	43b	J111-R
44a	J121-44b, J122-44b	44b	J122-44a, J123-44a
45a	J111-C	45b	J111-D
46a	J121-46b, J122-46b	46b	J122-46a, J123-46a
47a	J111-J	47b	J111-K
48a	J121-48b, J122-48b	48b	J122-48a, J123-48a
49a	J111-G	49b	J111-H
50a	J121-50b, J122-50b	50b	J122-50a, J123-50a

(d) WIRING TO J123
 BOARD 3 (ELECTRONIC FLYWHEEL)
 EDGE CONNECTOR

PIN NO.	CONNECTED TO	PIN NO.	CONNECTED TO
1a	J122-1b, J123-1b	1b	J123-1a, J124-1a
2a		2b	
3a		3b	
4a		4b	J124-37b
5a		5b	
6a		6b	
7a		7b	
8a		8b	
9a		9b	
10a	J122-10b, J123-10b	10b	J123-10a, J124-10a
11a		11b	
12a		12b	
13a		13b	
14a		14b	
15a		15b	J124-5b
16a		16b	J124-49b
17a		17b	J122-27a, J124-45b
18a		18b	J124-35b, J125-2a
19a		19b	
20a		20b	
21a		21b	
22a		22b	
23a		23b	
24a		24b	
25a		25b	
26a		26b	
27a		27b	
28a		28b	
29a		29b	
30a		30b	
31a		31b	
32a		32b	
33a		33b	
34a		34b	
35a		35b	
36a		36b	
37a		37b	
38a		38b	
39a		39b	
40a		40b	
41a		41b	
42a		42b	
43a		43b	
44a	J122-44b, J123-44b	44b	J123-44a, J124-44a
45a		45b	
46a	J122-46b, J123-46b	46b	J123-46a, J124-46a
47a		47b	
48a	J122-48b, J123-48b	48b	J123-48a, J124-48a
49a		49b	
50a	J122-50b, J123-50b	50b	J123-50a, J124-50a

(e) WIRING TO J124
BOARD 4 (CONTROL SIGNAL GENERATOR)
EDGE CONNECTOR

PIN NO.	CONNECTED TO	PIN NO.	CONNECTED TO
1a	J123-1b, J124-1b	1b	J124-1a, J125-1a
2a		2b	J126-3b
3a		3b	J126-3a
4a		4b	J126-37b
5a		5b	J123-15b
6a		6b	P169-6
7a		7b	J125-3b
8a		8b	J125-4b
9a		9b	J125-45a, J126-2b
10a	J123-10b, J124-10b, J120-20b	10b	J124-10a, J125-10a
11a		11b	P169-10
12a		12b	P169-11
13a		13b	P169-12
14a		14b	P169-9
15a		15b	P169-8
16a		16b	P169-7
17a		17b	P169-5
18a		18b	P169-4
19a		19b	P169-3
20a		20b	P169-2
21a		21b	P170-6
22a		22b	P170-10
23a		23b	P170-11
24a		24b	P170-12
25a		25b	P170-9
26a	J128-23b	26b	
27a		27b	P170-8
28a		28b	P170-7
29a		29b	P170-5
30a		30b	P170-4
31a		31b	P170-3
32a		32b	P170-2
33a		33b	J125-42b
34a		34b	J128-33b
35a		35b	J123-18b
36a		36b	J125-2b
37a		37b	J123-4b
38a	J125-35a	38b	J125-40b
39a		39b	
40a	J125-34a	40b	
41a		41b	
42a	J125-28b	42b	J121-47a
43a	J125-33b	43b	
44a	J123-44b, J124-44b	44b	J124-44a, J125-44a
45a	J125-42a	45b	J123-17b
46a	J123-46b, J124-46b	46b	J124-46a, J125-46a
47a	J125-9b	47b	J128-38b
48a	J123-48b, J124-48b	48b	J124-48a, J125-48a
49a	J125-17b	49b	J123-16b
50a	J123-50b, J124-50b	50b	J124-50a, J125-50a

(f) WIRING TO J125
BOARD 5 (SERIAL TO PARALLEL CONVERTER)
EDGE CONNECTOR

PIN NO.	CONNECTED TO	PIN NO.	CONNECTED TO
1a	J124-1b, J125-1b, J125-5a	1b	J125-1a, J126-1a
2a	J123-18b	2b	J124-36b
3a	J122-32a	3b	J124-7b
4a	J122-21a	4b	J124-8b
5a	J122-19a	5b	J121-7b, J126-15b
6a	J122-23a	6b	J121-11a, J126-15a
7a	J122-30a	7b	J121-11b, J126-41a
8a		8b	J121-14a, J126-41b
9a		9b	J124-47a
10a	J124-10b, J125-10b	10b	J125-10a, J126-10a
11a		11b	
12a		12b	
13a		13b	J121-14b, J126-25a
14a		14b	J121-17a, J126-25b
15a		15b	J121-17b, J126-14a
16a		16b	J121-20a, J126-14b
17a		17b	J124-49a
18a		18b	J121-30a
19a		19b	J121-20b, J126-28a
20a		20b	J121-23a, J126-28b
21a		21b	J121-23b, J126-24a
22a		22b	J121-27a, J126-24b
23a		23b	
24a		24b	
25a		25b	
26a		26b	
27a		27b	
28a		28b	J124-42a
29a		29b	
30a		30b	
31a		31b	
32a		32b	
33a		33b	J124-43a
34a	J124-40a	34b	
35a	J124-38a	35b	
36a		36b	J121-36b, J126-40b
37a		37b	J121-36a, J126-40a
38a		38b	J121-39a, J126-27b
39a		39b	J121-39b, J126-27a
40a		40b	J124-38b
41a		41b	J122-16a
42a	J124-45a	42b	J124-33b
43a		43b	J122-17a
44a	J124-44b, J125-44b	44b	J125-44a, J126-44a
45a	J124-9b	45b	J127-40a
46a	J124-46b, J125-46b	46b	J125-46a, J126-46b
47a		47b	J127-45a
48a	J124-48b, J125-48b	48b	J125-48a, J126-48b
49a		49b	
50a	J124-50b, J125-50b, J125-1a	50b	J125-50a, J126-50a

(g) WIRING TO J126
 BOARD 6 (TIME-OF-DAY STORE AND PRESET STOP
 GENERATOR) EDGE CONNECTOR

PIN NO.	CONNECTED TO	PIN NO.	CONNECTED TO
1a	J125-1b, J126-1b, S3-1	1b	J126-1a, J127-1a, P154-4
2a	S2-2	2b	J124-9b
3a	J124-3b	3b	J124-2b
4a	J121-7a	4b	J127-49a
5a	P164-8	5b	P151-3, P164-3
6a	P164-9	6b	P151-8, P164-4
7a	P164-10	7b	P151-9, P164-5
8a	P163-7	8b	P152-10, P163-2
9a	P166-9	9b	P149-8, P166-4
10a	J125-10b, J126-10b, S2-1	10b	J126-10a, J127-10a, P154-2
11a	P166-10	11b	P149-9, P166-5
12a	P165-7	12b	P150-10, P165-2
13a	P165-8	13b	P150-3, P165-3
14a	J125-15b, J127-24b	14b	J125-16b, J127-25b
15a	J125-6b, J127-21b	15b	J125-5b, J127-29b
16a	P163-8	16b	P152-3, P163-3
17a	P163-9	17b	P152-8, P163-4
18a	P163-10	18b	P152-9, P163-5, J121-30b
19a	P162-8	19b	P153-3, P162-3
20a	P165-9	20b	P150-8, P165-4
21a	P165-10	21b	P150-9, P165-5
22a	P168-9	22b	P147-8, P168-4
23a	P168-10	23b	P147-9, P168-5
24a	J125-21b, J127-30b	24b	J125-22b, J127-32b
25a	J125-13b, J127-23b	25b	J125-14b, J127-31b
26a		26b	
27a	J125-39b, J127-38a	27b	J125-38b, J127-37b
28a	J125-19b, J127-36a	28b	J125-20b, J127-35b
29a	P167-7	29b	P148-10, P167-2
30a	P167-8	30b	P148-3, P167-3
31a	P167-9	31b	P148-8, P167-4
32a	P167-10	32b	P148-9, P167-5
33a	P162-9	33b	P153-8, P162-4
34a	P162-10	34b	P153-9, P162-5, J121-33b
35a	P161-7	35b	P154-10, P161-2
36a	P161-8	36b	P154-3, P161-3
37a	J128-22b	37b	J124-4b
38a	P161-9	38b	P154-8, P161-4
39a	P161-10	39b	P154-9, P161-5, J121-42a
40a	J125-37b, J127-37a	40b	J125-36b, J127-36b
41a	J125-7b, J127-20b	41b	J125-8b, J127-18b
42a	J127-39a	42b	J127-47a
43a	S3-2	43b	P168-6
44a	J125-44b, J126-44b	44b	J126-44a, J127-44a
45a	P167-6	45b	P166-6
46a	P165-6	46b	J125-46b, J127-46a
47a	P164-6	47b	P163-6
48a	J125-48b, J126-48b	48b	J126-48a, J127-48a
49a	P162-6	49b	P161-6
50a	J125-50b, J126-50b	50b	J126-50a, J127-50a

(h) WIRING TO J127
BOARD 7 (SELECTED DATA AND FIXED DATA STORE) EDGE
CONNECTOR

PIN NO.	CONNECTED TO	PIN NO.	CONNECTED TO
1a	J126-1b, J127-1b, P160-4	1b	J127-1a, J128-1a, P148-4
2a	P156-3	2b	
3a	P155-3	3b	
4a	P146-8	4b	
5a	P145-9	5b	
6a		6b	
7a	P141-10	7b	
8a	P160-9	8b	
9a	P159-9	9b	
10a	J126-10b, J127-10b, P160-2, P133-4	10b	J127-10a, J128-10a, P148-2
11a	P160-3	11b	
12a	P160-8	12b	
13a	P141-3	13b	
14a	P146-9	14b	
15a	P146-10	15b	
16a	P146-3	16b	
17a	P155-8	17b	
18a	P155-9	18b	J126-41b
19a	P157-8	19b	
20a	P156-8	20b	J126-41a
21a		21b	J126-15a
22a	P143-10	22b	
23a	P143-3	23b	J126-25a
24a		24b	J126-14a
25a	P156-9	25b	J126-14b
26a		26b	
27a	P157-3	27b	
28a	P142-9	28b	
29a	P143-8	29b	J126-15b
30a	P141-9	30b	J126-24a
31a	P142-10	31b	J126-25b
32a	P142-3	32b	J126-24b
33a	P141-8	33b	
34a	P143-9	34b	
35a	P142-8	35b	J126-28b
36a	J126-28a	36b	J126-40b
37a	J126-40a	37b	J126-27b
38a	J126-27a	38b	P144-1c
39a	J126-42a	39b	P144-3
40a	J125-45b	40b	P144-8
41a		41b	
42a	P133-5	42b	P144-9
43a	P133-3	43b	P157-9
44a	J126-44b, J127-44b	44b	J127-44a, J128-44a
45a	J125-47b	45b	P158-3
46a	J126-46b, J127-46b	46b	J127-46a, J128-46a
47a	J126-42b	47b	P158-8
48a	J126-48b, J127-48b	48b	J127-48a, J128-48a
49a	J126-4b	49b	P158-9
50a	J126-50b, J127-50b	50b	J127-50a, J128-50a

(i) WIRING TO J128
BOARD 8 (COMPUTER INTERRUPT CONTROLLER)

PIN NO.	CONNECTED TO	PIN NO.	CONNECTED TO
1a	J127-1b, J128-1b, J128-50a	1b	J128-1a, J129-1a
2a		2b	
3a		3b	
4a		4b	
5a		5b	
6a		6b	
7a		7b	
8a		8b	
9a		9b	
10a	J127-10b, J128-10b	10b	J128-10a, J129-10a
11a		11b	
12a		12b	
13a		13b	
14a		14b	
15a		15b	
16a		16b	
17a		17b	
18a		18b	
19a		19b	
20a		20b	J121-42b
21a		21b	
22a		22b	J126-37a
23a		23b	J124-26a
24a		24b	
25a		25b	
26a		26b	
27a		27b	
28a		28b	J121-28b
29a		29b	
30a		30b	
31a		31b	
32a		32b	
33a		33b	J124-34b
34a		34b	
35a		35b	
36a		36b	
37a		37b	
38a		38b	J124-47b
39a		39b	
40a		40b	
41a		41b	
42a		42b	
43a		43b	
44a	J127-44b, J128-44b	44b	J128-44a, J129-44a
45a		45b	J121-47b
46a	J127-46b, J128-46b	46b	J128-46a, J129-46a
47a		47b	J121-33a
48a	J127-48b, J128-48b	48b	J128-48a, J129-48a
49a		49b	
50a	J127-50b, J128-50b, J128-1a	50b	J128-50a, J129-50a

(j) WIRING TO J129

PIN NO.	CONNECTED TO	PIN NO.	CONNECTED TO
1a	J128-1b, J129-1b	1b	J129-1a, J130-1a
2a		2b	
3a		3b	
4a		4b	
5a		5b	
6a		6b	
7a		7b	
8a		8b	
9a		9b	
10a	J128-10b, J129-10b	10b	J129-10a, J130-10a
11a		11b	
12a		12b	
13a		13b	
14a		14b	
15a		15b	
16a		16b	
17a		17b	
18a		18b	
19a		19b	
20a		20b	
21a		21b	
22a		22b	
23a		23b	
24a		24b	
25a		25b	
26a		26b	
27a		27b	
28a		28b	
29a		29b	
30a		30b	
31a		31b	
32a		32b	
33a		33b	
34a		34b	
35a		35b	
36a		36b	
37a		37b	
38a		38b	
39a		39b	
40a		40b	
41a		41b	
42a		42b	
43a		43b	
44a	J128-44b, J129-44b	44b	J129-44a, J130-44a
45a		45b	
46a	J128-46b, J129-46b	46b	J129-46a, J130-46a
47a		47b	
48a	J128-48b, J129-48b	48b	J129-48a, J130-48a
49a		49b	
50a	J128-50b, J129-50b	50b	J129-50a, J130-50a

(k) WIRING TO J130

PIN NO.	CONNECTED TO	PIN NO.	CONNECTED TO
1a	J129-1b, J130-1b	1b	J130-1a, J131-1a
2a		2b	
3a		3b	
4a		4b	
5a		5b	
6a		6b	
7a		7b	
8a		8b	
9a		9b	
10a	J129-10b, J130-10b	10b	J130-10a, J131-10a
11a		11b	
12a		12b	
13a		13b	
14a		14b	
15a		15b	
16a		16b	
17a		17b	
18a		18b	
19a		19b	
20a		20b	
21a		21b	
22a		22b	
23a		23b	
24a		24b	
25a		25b	
26a		26b	
27a		27b	
28a		28b	
29a		29b	
30a		30b	
31a		31b	
32a		32b	
33a		33b	
34a		34b	
35a		35b	
36a		36b	
37a		37b	
38a		38b	
39a		39b	
40a		40b	
41a		41b	
42a		42b	
43a		43b	
44a	J129-44b, J130-44b	44b	J130-44a, J131-44a
45a		45b	
46a	J129-46b, J130-46b	46b	J130-46a, J131-46a
47a		47b	
48a	J129-48b, J130-48b	48b	J130-48a, J131-48a
49a		49b	
50a	J129-50b, J130-50b	50b	J130-50a, J131-50a

(1) WIRING TO J131

PIN NO.	CONNECTED TO	PIN NO.	CONNECTED TO
1a	J130-1b, J131-1b, J131-50a	1b	J131-1a
2a		2b	
3a		3b	
4a		4b	
5a		5b	
6a		6b	
7a		7b	
8a		8b	
9a		9b	
10a	J130-10b, J131-10b	10b	J131-10a
11a		11b	
12a		12b	
13a		13b	
14a		14b	
15a		15b	
16a		16b	
17a		17b	
18a		18b	
19a		19b	
20a		20b	
21a		21b	
22a		22b	
23a		23b	
24a		24b	
25a		25b	
26a		26b	
27a		27b	
28a		28b	
29a		29b	
30a		30b	
31a		31b	
32a		32b	
33a		33b	
34a		34b	
35a		35b	
36a		36b	
37a		37b	
38a		38b	
39a		39b	
40a		40b	
41a		41b	
42a		42b	
43a		43b	
44a	J130-44b, J131-44b	44b	J131-44a
45a		45b	
46a	J130-46b, J131-46b	46b	J131-46a
47a		47b	
48a	J130-48b, J131-48b	48b	J131-48a
49a		49b	
50a	J130-50b, J131-50b, J131-1a	50b	J131-50a

5. COMPONENT IDENTIFICATION

Components used on printed circuits and elsewhere have been given an identification label (or legend) consisting of a letter prefix followed by a number comprising up to three digits. The letter prefix identifies the class of component as indicated in the following table:

CLASS OF COMPONENT	LETTER PREFIX
Resistor	R
Capacitor	C
Transformer	L
Diode	CR
Transistor or Integrated Circuit	O
Switch	S
Numeric Indicator Valve	V
Relay	K
Heat Sink	HS
Test Point	TP
Terminal Board	TB
Indicator Lamp	LP
Chassis Mounted Connector	J
Cable Mounted Connector or Edge	P
Connector Contacts on Printed Circuit Board	
Terminal	TM

Components mounted on the plug-in printed circuit cards are individually identified by a three digit number following the letter prefix. Of these digits the first identifies which particular card the component is on, and the remaining two identify the particular component. For example R312 means resistor 12 on printed circuit card 3. In the case of components for the AC to DC converter (Fig. 4) and some components mounted on the front panel (Figs. 28a, 28b and 29) the first digit has been omitted.

The card identifiers are marked on the card extractors (which are mounted on the cards) and are also marked on the corresponding card locations in the interface box. Complete component identification labels are included on circuit diagrams and component layout diagrams. Card identifiers are allocated as indicated in the following table.

BOARD DESCRIPTION	CARD IDENTIFIER	CARD SLOT NUMBER	SERIAL NUMBER
AC to DC Converter	First digit omitted	Not plug-in	FL-01-07-01
Voltage Regulators	0	0	FL-01-07-02
Output Buffers	1	1	FL-01-07-03
Input Clock Signal Generator	2	2	FL-01-07-04
Electronic Flywheel	3	3	FL-01-07-05
Control Signal Generator for Serial System	4A	4	FL-01-07-06
Control Signal Generator for Parallel System	4B	4	FL-01-07-10
Serial to Parallel Converter for Serial System	5A	5	FL-01-07-07
Serial to Parallel Converter for Parallel System	5B	5	FL-01-07-11
Time-of-Day Store and Pre-Set Stop Generator	6	6	FL-01-07-08
Selected Data and Fixed Data Store	7	7	FL-01-07-09
Computer Interrupt Controller	8	8	FL-01-07-12
Spare		9	
Spare		10	
Spare		11	

Repetition of a particular sub-circuit within an integrated circuit (e.g. two-input NAND gate is repeated four times in the SN7400N) is indicated by consecutive letters following the integrated circuit identifier (e.g. if Q403 is a type SN7400N then Q403A, Q403B, Q403C and Q403D would serve to identify each sub-circuit).

Chassis mounted components (excluding connectors) are given a number identifier of up to two digits only.

Connectors (both cable and chassis types) are given a three digit identifier where the first digit is a unit identifier which, for the interface, is 1. Mating plugs and sockets are always given the same number identification.

Each unit of airborne or ground equipment manufactured is given a serial number of the form FL- n_1n_2 - n_3n_4 . "FL" is an abbreviation for "FLIGHT", n_1n_2 is a two digit project identifier and n_3n_4 is a two digit equipment identifier. In the case of the interface the serial number is FL-01-07 where the "01" refers to the project "airborne data acquisition and ground station data reduction" and the "07" refers to the interface equipment.

Printed circuit cards are also given serial numbers consisting of the unit serial number followed by a particular board identification (e.g. FL-01-07-02). Boards manufactured for the interface have the serial numbers given in the previous table.

6. INTEGRATED CIRCUIT WIRING DETAILS

Any digital integrated circuit connections (including power) which are not given on the circuit diagrams are included in the following tables. Dual-in-line packages have been used throughout. The package size is indicated in each case (where 14DIL means 14 pin dual-in-line package and similarly for 16DIL).

All digital integrated circuits are mounted with a 10,000 picofarad power supply bypass capacitor in close proximity to the device.

DEVICE IDENTIFICATION		CONNECTED TO COM. (GND.)	CONNECTED TO VCC	OTHER DETAILS	PACKAGE SIZE
LEGEND	TYPE				
Q101	SN7404N	7	14		14 DIL
Q102	SN7404N	7	14		14 DIL
Q103	SN7404N	7	14		14 DIL
Q104	SN7404N	7	14		14 DIL
Q105	SN7404N	7	14		14 DIL
Q106	SN7404N	7	14		14 DIL
Q107	SN7404N	7	14		14 DIL
Q108	SN7404N	7	14		14 DIL
Q109	SN7404N	7	14		14 DIL
Q110	SN7404N	7	14		14 DIL
Q111	SN7404N	7	14		14 DIL
Q112	SN7404N	7	14		14 DIL
Q113	SN7404N	7	14		14 DIL
Q114	SN7404N	7	14		14 DIL
Q201	SN7404N	7	14		14 DIL
Q202	SN7404N	7	14		14 DIL
Q203	SN7404N	7	14		14 DIL
Q204	SN7402N	7	14		14 DIL
Q205	SN7402N	7	14		14 DIL
Q206	SN7430N	7	14		14 DIL
Q301	SN74121N	7	9,14		14 DIL
Q302	SN7400N	7	14		14 DIL
Q401	SN7490N	6,7,10	5	1 connected to 12 and 2 connected to 3	14 DIL
Q402	SN7442N	8	16		16 DIL
Q403	SN7400N	7	14		14 DIL
Q404	SN7490N	6,7,10	5	2 connected to 3	14 DIL
Q405	SN7404N	7	5		14 DIL
Q406	SN7476N	1,4,13,16	5,8,9,12		16 DIL
Q407	SN7400N	7	14		14 DIL
Q408	SN7476N	2,3,10	5		16 DIL
Q409	SN7402N	7	14		14 DIL
Q410	SN7442N	8	16		16 DIL
Q411	SN7442N	8	16		16 DIL
Q412	SN7490N	6,7,10	5	1 connected to 12 and 2 connected to 3	14 DIL

DEVICE IDENTIFICATION		CONNECTED	CONNECTED	OTHER DETAILS	PACKAGE
LEGEND	TYPE	TO COM. (GND.)	TO V _{CC}		SIZE
Q413	SN7490N	6,7,10	5	1 connected to 12 and 2 connected to 3	14 DIL
Q414	SN7400N	7	14		14 DIL
Q415	SN7404N	7	14		14 DIL
Q416	SN7402N	7	14		14 DIL
Q451	SN7408N	7	14		14 DIL
Q452	SN7408N	7	14		14 DIL
Q453	SN7402N	7	14		14 DIL
Q454	SN7476N	13	2,4,5,7, 9,12,16		16 DIL
Q455	SN7400N	7	14		14 DIL
Q456	SN7400N	7	14		14 DIL
Q457	SN7476N	13	3,4,5,8, 9,12,16		16 DIL
Q458	SN7476N	1,4,13,16	5,7,9,12		16 DIL
Q459	SN7402N	7	14		14 DIL
Q460	SN7400N	7	14		14 DIL
Q461	SN7442N	8	16		16 DIL
Q462	SN7442N	8	16		16 DIL
Q463	SN7490N	6,7,10	5	1 connected to 12 and 2 connected to 3	14 DIL
Q464	SN7490N	6,7,10	5	1 connected to 12 and 2 connected to 3	14 DIL
Q465	SN7408N	7	14		14 DIL
Q501	SN7495N	6,7	14		14 DIL
Q502	SN7495N	6,7	14		14 DIL
Q503	SN7495N	6,7	14		14 DIL
Q504	SN7495N	6,7	14		14 DIL
Q505	SN7400N	7	14		14 DIL
Q506	SN7400N	7	14		14 DIL
Q507	SN7450N	7	14		14 DIL
Q508	SN7476N	1,4,13,16	5,7,9,12		16 DIL
Q509	SN7404N	7	14		14 DIL

DEVICE IDENTIFICATION		CONNECTED TO COM. (GND.)	CONNECTED TO V _{CC}	OTHER DETAILS	PACKAGE SIZE
LEGEND	TYPE				
Q551	SN7400N	7	14		14 DIL
Q552	SN7400N	7	14		14 DIL
Q553	SN7400N	7	14		14 DIL
Q554	SN7400N	7	14		14 DIL
Q555	SN7400N	7	14		14 DIL
Q556	SN7400N	7	14		14 DIL
Q557	SN7475N	12	5		16 DIL
Q558	SN7475N	12	5		16 DIL
Q559	SN7475N	12	5		16 DIL
Q560	SN7475N	12	5		16 DIL
Q561	DM8220	7	14		14 DIL
Q601	SN7400N	7	14		14 DIL
Q602	SN7430N	7	14		14 DIL
Q603	SN7440N	7	14		14 DIL
Q604	SN7400N	7	14		14 DIL
Q605	SN7400N	7	14		14 DIL
Q606	SN7402N	7	14		14 DIL
Q607	SN7475N	12	5		16 DIL
Q608	SN7475N	12	5		16 DIL
Q609	SN7475N	12	5		16 DIL
Q610	SN7475N	12	5		16 DIL
Q611	SN7475N	12	5		16 DIL
Q612	SN7475N	12	5		16 DIL
Q613	SN7475N	12	5		16 DIL
Q701	SN7440N	7	14		14 DIL
Q702	SN7440N	7	14		14 DIL
Q703	SN7440N	7	14		14 DIL
Q704	SN7475N	12	5		16 DIL
Q705	SN7475N	12	5		16 DIL
Q706	SN7475N	12	5		16 DIL
Q707	SN7475N	12	5		16 DIL
Q708	SN7475N	12	5		16 DIL
Q709	SN7475N	12	5		16 DIL
Q710	SN7475N	12	5		16 DIL
Q711	SN7475N	12	5		16 DIL
Q712	SN7475N	12	5		16 DIL
Q713	SN7475N	12	5		16 DIL
Q714	SN7404N	7	14		14 DIL
Q715	SN7404N	7	14		14 DIL
Q716	SN7404N	7	14		14 DIL
Q801	SN7400N	7	14		14 DIL
Q802	SN7474N	7	14, 4, 2, 10, 12		14 DIL

7. COMPONENT LISTS

The following tables list the components used in the interface. Resistance and capacitance values given in these tables (and also marked on the circuit diagrams) are respectively in ohm and picofarad (where $K = 10^3$ and $M = 10^6$). Thus a capacitance value designated 1.5K means 1500 picofarad and a capacitance value designated 10M means 10 microfarad.

7.1 Components for AC to DC Converter (incorporates Board FL-01-07-01)

LEGEND	VALUE	DESCRIPTION															
R01	1K	Resistor, fixed, carbon, Philips CR25, 5%, 0.3 watt															
R02	15K	Resistor, fixed, wirewound, Welwyn W22 Series, 5%, 6 watts															
R03	15K	As for R02															
R04	15K	As for R02															
R05	180K	As for R01															
R06	180K	As for R01															
C01	50M	Capacitor, fixed, electrolytic, 35 VW Wima Printilyt															
C02	10,000M	As for C01 but two 5000M units connected in parallel															
C03	50M	As for C01															
C04	500M	As for C01															
C05	500M	As for C01															
C06	50M	Capacitor, fixed, electrolytic, 300 VW, Ducon Type ET6C															
L01		Inductor, specially wound on core used for Trimax TP5080 power transformer, 14 B&S wire used, full window space utilized															
L02		Transformer, power, core and primary winding as for Trimax TP5080, four secondary windings incorporated:															
		<table border="1"> <thead> <tr> <th>Winding No.</th> <th>Nominal Voltage</th> <th>Wire Details</th> </tr> </thead> <tbody> <tr> <td>1</td> <td>15V RMS at 160mA</td> <td>91 Turns 28 B&S</td> </tr> <tr> <td>2</td> <td>15V RMS at 160mA</td> <td>91 Turns 28 B&S</td> </tr> <tr> <td>3</td> <td>152V RMS at 64mA</td> <td>880 Turns 32 B&S</td> </tr> <tr> <td>4</td> <td>12V RMS at 4A</td> <td>74 Turns 14 B&S</td> </tr> </tbody> </table>	Winding No.	Nominal Voltage	Wire Details	1	15V RMS at 160mA	91 Turns 28 B&S	2	15V RMS at 160mA	91 Turns 28 B&S	3	152V RMS at 64mA	880 Turns 32 B&S	4	12V RMS at 4A	74 Turns 14 B&S
Winding No.	Nominal Voltage	Wire Details															
1	15V RMS at 160mA	91 Turns 28 B&S															
2	15V RMS at 160mA	91 Turns 28 B&S															
3	152V RMS at 64mA	880 Turns 32 B&S															
4	12V RMS at 4A	74 Turns 14 B&S															
CR01		Diode, silicon, 6A, Type BYX48-900															
CR02		As for CR01															
CR03		Diode, silicon, 6A, Type BYX48-900R															
CR04		As for CR03															
CR05		Diode, silicon, 1A, Type 1N4003															
CR06		As for CR05															
CR07		Rectifier bridge assembly, 1.5A, 100 P.I.V. Type MDA942-2															
CR08		As for CR07															
CR09		Diode, silicon, 1A, 1000 P.I.V., Type 1N4007															
CR10		As for CR09															
CR11		As for CR09															
CR12		As for CR09															
HS01		Heatsink, Thermalloy Type 1032B															
HS02		As for HS01															
HS03		As for HS01															
HS04		As for HS01															
PL32		Plug, cable mounted, comprising a Souriau type 8140-115 8-pin (designated 1a to 8a) connector clamped to a Souriau type 8140-02 5-pin (designated 1b to 5b) connector.															

7.2 Components for Voltage Regulators (Ser. No. FL-01-07-02)

LEGEND	VALUE	DESCRIPTION
R001	1.5K	Resistor, fixed, carbon, Philips CR25, 5%, 0.3 watt
R002	2.2K	Resistor, fixed, glass-tin-oxide, Electrosil Type TR4, 1%
R003	500	Resistor, variable, wirewound, Bourns 3005P
R004	750	As for R002
R005	47	Resistor, fixed, wirewound, Welwyn W21 series, 5%, 2.5 watt
R006	0.1	As for R005
R007	10	As for R001
R008	2.2K	As for R002
R009	1K	As for R003
R010	4.7K	As for R002
R011	3.9K	As for R001
R012	10K	As for R001
R013	1K	As for R001
R014	1K	As for R001
R015	3.9K	As for R001
R016	1K	As for R001
R017	1	As for R005
R018	47	As for R005
R019	18	Resistor, fixed, wirewound, Welwyn W22 Series, 5%, 6 watt
R020	6.8	As for R005
R021	6.8	As for R005
R022	2.7	As for R005
R023	4.7	As for R005
R024	15	As for R002
R025	16K	As for R002
R026	1K	As for R003
R027	2K	As for R002
C001	250M	Capacitor, fixed, electrolytic, 35 WV, Wima Printilyt
C002	100K	Capacitor, fixed, ceramic, Vitramon 33B ¹ series
C003	22K	As for C002
C004		Not used, space provided on printed circuit
C005	1K	Capacitor, fixed, ceramic, Ducon Type CDS, Curve Y, Style AY
C006	100K	As for C002
C007	100M	As for C001
C008	100K	As for C002
C009	680K	Capacitor, fixed, metallized film, 63WV, Wima Type MKS
C010	680K	As for C009
C011	100K	As for C002
C012	250M	As for C001

LEGEND	VALUE	DESCRIPTION
C013	250M	As for C001
C014	100K	As for C002
C015	100K	As for C002
C016	150	Capacitor, fixed, ceramic, Ducon Type CDS, Curve Y, Style FY
C017	100	As for C016
C018	25M	As for C001
C019	25M	As for C001
C020	100K	As for C002
C021	100K	As for C002
Q001		Integrated circuit regulator, UA723C
Q002		Transistor, silicon, NPN, 2N2102
Q003		Transistor, silicon, NPN, 2N3055
Q004		Transistor, silicon, NPN, SE4010
Q005		As for Q004
Q006		Transistor, silicon, PNP, AY6102
Q007		Transistor, silicon, PNP, 2N3502
Q008		Integrated circuit regulator, LM305
Q009		Integrated circuit regulator, LM304
Q010		As for Q007
CR001		Diode, Zener, 1Z9.1T5, 1 watt, 9.1 volt nominal
CR002		Diode, Zener, BZY88 series, C7V5, 400 milliwatt, 7.5 volt nominal
CR003		Diode, silicon, A15N (1N5627)
CR004		Silicon controlled rectifier, 2N4216
CR005		Diode silicon, 0A202
HS001		Heatsink, Augat 9006-1G1
HS002		Heatsink, GRI Type 21
HS003		Heatsink, GRI Type 21
K001		Relay, 4 changeover DC, 6V coil, 3A contact rating, Type MAT 4B, Takamisawa Electric Co. Ltd., Supplied by Relays Pty. Ltd.
TP01		Test point, red, Amp Part No. 3-582118-2
TP02		Test point, black, Amp Part No. 3-582118-0
TP03		Test point, yellow, Amp Part No. 3-582118-4
TP04		Test point, black, Amp Part No. 3-582118-0
TP05		Test point, blue, Amp Part No. 3-582118-6

7.3 Components for Output Buffers (Ser. No. FL-01-07-03)

LEGEND	VALUE	DESCRIPTION
R101 to R156	33	Resistor, fixed, carbon, Philips Type CR16, 0.1 watt, 5%
C101 C102 to C115	6.8M 10K	Capacitor, fixed, electrolytic, tantalum, Sprague Type 196D, 35 WV, Part No. 196D685X0035DB Capacitor, fixed, ceramic, Vitramon VK33BW series (Bypass capacitors for Q101 to Q114)
Q101 to Q114		Integrated circuit, hex inverter, SN7404N

7.4 Components for Input Clock Signal Generator (Ser. No. FL-01-07-04)

LEGEND	VALUE	DESCRIPTION
R201 to R207	100	Resistor, fixed, carbon, Philips Type CR25, 0.3 watt, 5%
R208 to R214	47K	As for R201
R215 to R228	470	As for R201
C201 to C207	220	Capacitor, fixed, ceramic, Ducon Type CDS, Curve Y, Style FY
C208 to C221	10K	Capacitor, fixed, ceramic, Vitramon VK33BW series
C222	6.8M	Capacitor, fixed, electrolytic, tantalum, Sprague Type 196D, 35 VW, Part No. 196D685X0035DB
C223 to C228	10K	As for C208 (Bypass capacitors for Q201 to Q206)
Q201		Integrated circuit, hex inverter, SN7404N
Q202		As for Q201
Q203		As for Q201
Q204		Integrated circuit, quad 2-input NOR gate, SN7402N
Q205		As for Q204
Q206		Integrated circuit, 8-input NAND gate, SN7430N
TP21		Test point, white, Amp Part No. 3-582118-9
TP22		yellow -4
TP23		green -5
TP24		white -9
TP25		yellow -4
TP26		green -5
TP27		blue -6
TP28		black -0

7.5 Components for Electronic Flywheel (Ser. No. FL-01-07-05)

LEGEND	VALUE	DESCRIPTION
R301	3.3K	Resistor, fixed, carbon, Philips Type CR25, 0.3 watt, 5%
R302	1K	As for R301
R303	22K	As for R301
R304	10K	As for R301
R305	100K	Resistor, fixed, glass-tin oxide Electrosil RFG-5-F, 0.25 watt, 1%, 100 ppm/°C
R306	4.7K	As for R301
R307	15K	As for R301
R308	100	As for R301
R309	4.7K	As for R301
R310	2.2K	As for R301
R311	470	As for R301
R312	2.2K	As for R301
R313	2.7K	As for R301
R314	10K	Resistor, variable, wirewound, Bourns 3005P
R315	1K	As for R301
R316	5K	As for R314
R317	100	As for R301
R318	8.2K	As for R301
R319	5K	As for R314
R320	12K	As for R301
R321	10K	As for R301
R322	5K	As for R314
R323	5.6K	As for R301
R324	1K	As for R301
R325	1K	As for R301
R326	1K	As for R301
R327	470	As for R301
R328	220	As for R301
C301	1.5K	Capacitor, Fixed, Ceramic, Ducon Type CDS, Curve Y, Style BY
C302	5M	Capacitor, Fixed, Electrolytic, 35 WV, Wima Printilyt
C303	220	Capacitor, Fixed, Ceramic, Ducon Type CDS, Curve Y, Style FY
C304	18K	Capacitor, Fixed, Polvester, Philips, 10%, 400 WV
C305	10K	Capacitor, Fixed, Metallized Film, 100 WV Wima Type MKS
C306	2.7M	Capacitor, Fixed, Electrolytic, Tantalum, 50WV, Airtronic Type ATR
C307	1.8M	As for C306
C308	10M	As for C302
C309	100K	Capacitor, Fixed, Ceramic, Duncan Redcap, Type CDR, 25 WV
C310	100K	As for C309

LEGEND	VALUE	DESCRIPTION
C311	100	As for C303
C312	100K	As for C309
C313	100K	As for C309
C314	100	As for C303
C315	1.5K	As for C301
C316	820	Capacitor, Fixed, Ceramic, Ducon Type CDS, Curve Y, Style AY
C317	6.8M	Capacitor, Fixed, Electrolytic, Tantalum, Sprague Type 196D, 35 VW, Part No. 196D685X0035DB
C318	10K	As for C309
C319	10K	As for C309
C320	6.8M	As for C317
C321	6.8M	As for C317
C322	100	As for C303
CR301		Diode, Zener, BZY88 5.1V
CR302		Diode, Silicon OA202
CR303		As for CR302
CR304		Diode, Zener, BZY88 4.3V
CR305		As for CR304
Q301		Integrated circuit, Monostable Multivibrator, SN74121N
Q302		Integrated circuit, quad 2-input Nand gate, SN7400N
Q303		Transistor, silicon, AY6101
Q304		Transistor, silicon, SE4010
Q305		As for Q304
Q306		Transistor, silicon, 2N3566
Q307		Integrated circuit, analog comparator LM311D
Q308		As for Q307
TP31		Test point, white AMP Part No. 3-582118-9
TP32		yellow -4
TP33		green -5
TP34		blue -6
TP35		white -9
TP36		black -0
LK301		Multiway Link Package, 14 pin DIL. ERG. Type DIL pack-14
LK302		As for LK301 (used to store alternative link package)

7.6 Components for Control Signal Generator for Serial System
 (Ser. No. FL-01-07-06)

LEGEND	VALUE	DESCRIPTION
R401	470	Resistor, fixed, carbon, Philips Type CR25, 0.3 watt, 5%
R402	470	As for R401
R403	220	As for R401
R404	470	As for R401
C401	820	Capacitor, fixed, ceramic, Ducon Type CDS, Curve Y, Style AY
C402	820	As for C401
C403	820	As for C401
C404	820	As for C401
C405	6.8M	Capacitor, fixed, electrolytic, tantalum, Sprague Type 196D, 35 VW, Part No. 196D6P5X0035DB
C406 to C421	10K	Capacitor, fixed, ceramic, Vitramon VK33BW series (Bypass capacitors for Q401 to Q416)
Q401		Integrated circuit, decade counter, SN7490N
Q402		Integrated circuit, BCD to decimal decoder, SN7442N
Q403		Integrated circuit, quad 2-input NAND gate, SN7400N
Q404		As for Q401
Q405		Integrated circuit, hex inverter, SN7404N
Q406		Integrated circuit, dual J-K flip flop, SN7476N
Q407		As for Q403
Q408		As for Q401
Q409		Integrated circuit, quad 2-input NOR gate, SN7402N
Q410		As for Q402
Q411		As for Q402
Q412		As for Q401
Q413		As for Q401
Q414		As for Q403
Q415		As for Q405
Q416		As for Q409
TP41		Test point, white, AMP Part No. 3-582118-9
TP42		Test point, yellow -4
TP43		Test point, green -5
TP44		Test point, blue -6
TP45		Test point, white -9
TP46		Test point, yellow -4
TP47		Test point, green -5
TP48		Test point, black -0

7.7 Components for Control Signal Generator for Parallel System
(Ser. No. FL-01-07-10)

LEGEND	VALUE	DESCRIPTION
R451 to R455	470	Resistor, fixed, carbon, Philips Type CR25, 0.3 watt, 5%
C451 to C455	820	Capacitor, fixed, ceramic, Ducon Type CDS, Curve Y, Style AY
C456	6.8M	Capacitor, fixed, electrolytic, tantalum Sprague Type 196D, 35 VW, Part No. 196D685X0035DB
C457 to C471	10K	Capacitor, fixed, ceramic, Vitramon VK33BW series (Bypass capacitors for Q451 to Q465)
Q451 Q452 Q453 Q454 Q455 Q456 Q457 Q458 Q459 Q460 Q461 Q462 Q463 Q464 Q465		Integrated circuit, quad 2-input AND gate, SN7408N As for Q451 Integrated circuit, quad 2-input NOR gate, SN7402N Integrated circuit, dual J-K flip flop, SN7476N Integrated circuit, quad 2-input NAND gate, SN7400N As for Q455 As for Q454 As for Q454 As for Q454 As for Q453 As for Q455 Integrated circuit, BCD to decimal decoder, SN7442N As for Q461 Integrated circuit, decade counter, SN7490N As for Q463 As for Q451
TP41 TP42 TP43 TP44 TP45 TP46 TP47 TP48		Test point, white, AMP Part No. 3-582118-9 Test point, yellow, -4 Test point, green, -5 Test point, blue, -6 Test point, white, -9 Test point, yellow, -4 Test point, green, -5 Test point, black, -0

7.8 Components for Serial to Parallel Converter for Serial System:
(Ser. No. FL-01-07-07)

LEGEND	VALUE	DESCRIPTION
R501	470	Resistor, fixed, carbon, Philips Type CR25, 0.3 watt, 5%
C501	820	Capacitor, fixed, ceramic, Ducon Type CDS, Curve Y Style AY
C502	6.8M	Capacitor, fixed, electrolytic, tantalum, Sprague Type 196D, 35 WJ, Part No. 196D685X0035DB
C503 to C511	10K	Capacitor, fixed, ceramic, Vitramon VK33BW series (Bypass capacitors for Q501 to Q509)
Q501 Q502 Q503 Q504 Q505 Q506 Q507		Integrated circuit, 4-bit shift register, SN7405N As for Q501 As for Q501 As for Q501 Integrated circuit, quad 2-input NAND gate, SN7400N As for Q505 Integrated circuit, dual 2-wide 2-input AND-OR-INVERT gate SN7450N
Q508 Q509		Integrated circuit, dual J-K flip flop, SN7476N Integrated circuit, hex inverter SN7404N
TP51 TP52 TP53 TP54 TP55 TP56 TP57 TP58		Test point, white, AMP Part No. 3-582118-9 yellow -4 green -5 blue -6 white -9 yellow -4 green -5 black -0

7.9 Components for Serial to Parallel Converter for Parallel System
(Ser. No. FL-01-07-11)

LEGEND	VALUE	DESCRIPTION
R551	470	Resistor, fixed, carbon, Philips Type CR25, 0.3 watt, 5%
C551	820	Capacitor, fixed, ceramic, Ducon Type CDS, Curve Y, Style AY
C552	6.8M	Capacitor, fixed, electrolytic, tantalum, Sprague Type 196D, 35 VW, Part No. 196D685X0035DB
C553 to C563	10K	Capacitor, fixed, ceramic, Vitramon VK33BW series
Q551		Integrated circuit, quad 2-input NAND gate, SN7400N
Q552		As for Q551
Q553		As for Q551
Q554		As for Q551
Q555		As for Q551
Q556		As for Q551
Q557		Integrated circuit, four bit latch, SN7475N
Q558		As for Q557
Q559		As for Q557
Q560		As for Q557
Q561		Integrated circuit, parity checker, DM8220

7.10 Components for Time of Day Store and Preset Stop Generator (Ser. No. FL-01-07-08)

LEGEND	VALUE	DESCRIPTION
R601 to R609	10K	Resistor, fixed, carbon, Philips Type CR25, 0.3 watt, 5%
R610	100	As for R601
C601 } C602 } C603 }	Up to 100K	Capacitor, fixed, ceramic, Vitramon VK33BW series As for C601
C604 to C616	6.8M	Capacitor, fixed, electrolytic, tantalum, Sprague Type 196D, 35 VW, Part No. 196D685X0035DB
	10K	As for C601
Q601 Q602 Q603 Q604 Q605 Q606 Q607 to Q613		Integrated circuit, quad 2-input NAND gate, SN7400N Integrated circuit, 8-input NAND gate, SN7430N Integrated circuit, dual 4-input NAND buffer, SN7440N As for Q601 As for Q601 Integrated circuit, quad 2-input NOR gate, SN7402N Integrated circuit, 4-bit bistable latch SN7475N

7.11 Components for Selected Data and Fixed Data Store (Ser. no. FL-01-07-09)

LEGEND	VALUE	DESCRIPTION
C701	6.8M	Capacitor, fixed, electrolytic, tantalum, Sprague Type 196D, 35 VW, Part No. 196D685X0035DB
C702 to C717	10K	Capacitor, fixed, ceramic, Vitramon VK33BW series
Q701		Integrated circuit, dual 4-input NAND buffer, SN7440N
Q702		As for Q701
Q703		As for Q701
Q704 to Q713		Integrated circuit, 4-bit bistable latch, SN7475N
Q714		Integrated circuit, hex inverter, SN7404N
Q715		As for Q714
Q716		As for Q714

7.12 Components for Computer Interrupt Controller (Ser. No. FL-01-07-12)

LEGEND	VALUE	DESCRIPTION
C801	120K	Capacitor, fixed, ceramic, Vitromon VK33BW series
Q801		Integrated circuit, 4-input NAND gate, SN7400N
Q802		Integrated circuit, dual D flip-flop, SN7474N

7.13 Components for Front and Rear Panels and Chassis

For details on the application of these components refer to Sec. 4 and to Figs. 28a, 28b and 29.

LEGEND	DESCRIPTION
S1	Switch, toggle, double pole, changeover, Bulgin SM270, 2A rating
S2	Switch, toggle, double pole, changeover, Alco MST205N
S3	Switch, pushbutton, changeover, momentary, Alco MSP205R
S4A to S4H	Switch, thumbwheel, 10 position, decimal decoding, Contraves M5311, incorporating eight type OA95 germanium diodes
S5A and S5B	Switch, thumbwheel, 10 position, single pole, Contraves M010
S6	Switch, toggle, single pole, changeover, Alco MST105D
S7	As for S6
S8	As for S6
LP1	Indicator lamp, neon, Telite, 0.3 watt, 240 volt, FP7/CD/NR, red.
LP2	Indicator lamp, filament, 5 volt, General Illumination Series 200, Type M525, amber
LP3	As for LP2 but green
LP4	As for LP2 but green
F1	Fuse, Belling Lee type L575 fuseholder, Belling Lee Type L562/1A fuse link.
V1 to V20 Q1 to Q20	Indicator tube, numerals 0 to 9, Siemens type ZM1182 BCD to decimal decoder drive unit, Siemens type ZAB51001
J101	Plug, chassis, Cannon type KPT02E14-19P
J102	Socket, chassis, Cannon type KPT02E10-6S
J103	Socket, chassis, subminiature, Cannon type DD-50S
J110	Socket, chassis, Cannon type XLR-LNE-32
J111	As for J101
J112	As for J102
J113	As for J103

LEGEND	DESCRIPTION
J120 to J131	Socket, chassis, printed circuit edge mounting, 50 pin per side, Cannon type G050100A2BBL
J132	Socket, chassis mounted, comprising a Souriau type 8140-116 8-pin (designated 1a to 8a) connector clamped to a Souriau type 8140-01 5-pin connector (designated 1b to 5b)
J133	Plug, chassis mounted, Souriau type 8140-02 (incorporating bias socket in place of pin 1)
P133	Socket, cable mounted, Souriau type 8140-25 (incorporating bias pin in place of socket of pin 1)
P141 to P160	Socket, valve, 14 pin, Siemens type Q81-114
P161 to P170	Socket, printed circuit edge mounting, 12 contact, supplied by Contraves for use with their thumbwheel switches
TM1	Terminal, green, connected electrically to chassis and mains ground, mounted on rear panel, Acme Part No. C42-01
TM2	Terminal, black, connected electrically to digital common, mounted on rear panel, Acme Part No. C42-01
TB1	Terminal board, mounted near J132.

8. OUTPUT BUFFER CONNECTION DETAILS

The output buffer (Fig. 8) has an input designated q_n and outputs as q_n^F (interwired to front panel connectors) and q_n^R (interwired to rear panel connectors) where $1 \leq n \leq 28$. The insertion of an appropriate link associated with each buffer stage determines whether the q_n input signal will be inverted or not as it passes through the buffer. If the "A" position of the link is chosen (Figs. 8 and 9) then logically

$$q_n^F = q_n^R = q_n$$

whereas if the "B" position of the link is chosen

$$q_n^F = q_n^R = \overline{q_n}$$

Details of the required link connections together with other relevant information are given in the following table.

BUFFER OUTPUT SIGNAL IDENTIFIER*	LINK POSITION	SIGNAL DESCRIPTION
q1	B	FM CLK
q2	A	N _C (FRAME INT)
q3	A	m ₁₄ (2-SEC SYNC)
q4	B	4-FRAME SYNC
q5	B	T (TAPE MACHINE PRESET STOP)
q6	A	b ₃ (BIT 3)
q7		SPARE
q8		SPARE
q9	A	b ₁₃ (BIT 13)
q10	A	b ₁₂ (BIT 12)
q11	A	b ₁₄ (BIT 14)
q12	A	b ₁₅ (BIT 15-LSB)
q13	A	b ₀ (BIT 0 - MSB)
q14	A	b ₇ (BIT 7)
q15	A	b ₂ (BIT 2)
q16	A	b ₁ (BIT 1)
q17	A	I _C (WORD INT)
q18	A	m ₁₀ (20-SEC SYNC)
q19	A	P (PARITY CHECKBIT)
q20	A	m ₇ (2-MIN SYNC)
q21	A	b ₆ (BIT 6)
q22	A	b ₅ (BIT 5)
q23	A	b ₈ (BIT 8)
q24	A	DATA TRANSMITTED (INPUT)
q25	A	b ₁₀ (BIT 10)
q26	A	b ₉ (BIT 9)
q27	A	b ₄ (BIT 4)
q28	A	b ₁₁ (BIT 11)

* The "F" (front panel) and "R" (rear panel) subscripts are omitted from the output identifiers in this table.

REFERENCES

1. K.F. Fraser
and
U.R. Krieser
Ground Station Digital Interface.
ARL Mech. Eng. Report 158, September 1980.
2. K.F. Fraser
and
U.R. Krieser
Digital Reproducing Amplifiers for a
Magnetic Tape Recorder.
ARL Mech. Eng. Note 337, September 1972.
3. K.F. Fraser
and
U.R. Krieser
Serial Digital Data Generator.
ARL Mech. Eng. Note 327, July 1971.
4. U.R. Krieser
Remote Control for Tape Machine.
To be published at ARL.
5. K.F. Fraser
and
U.R. Krieser
Airborne Data Processor.
ARL Mech. Eng. Report 153, November 1978.

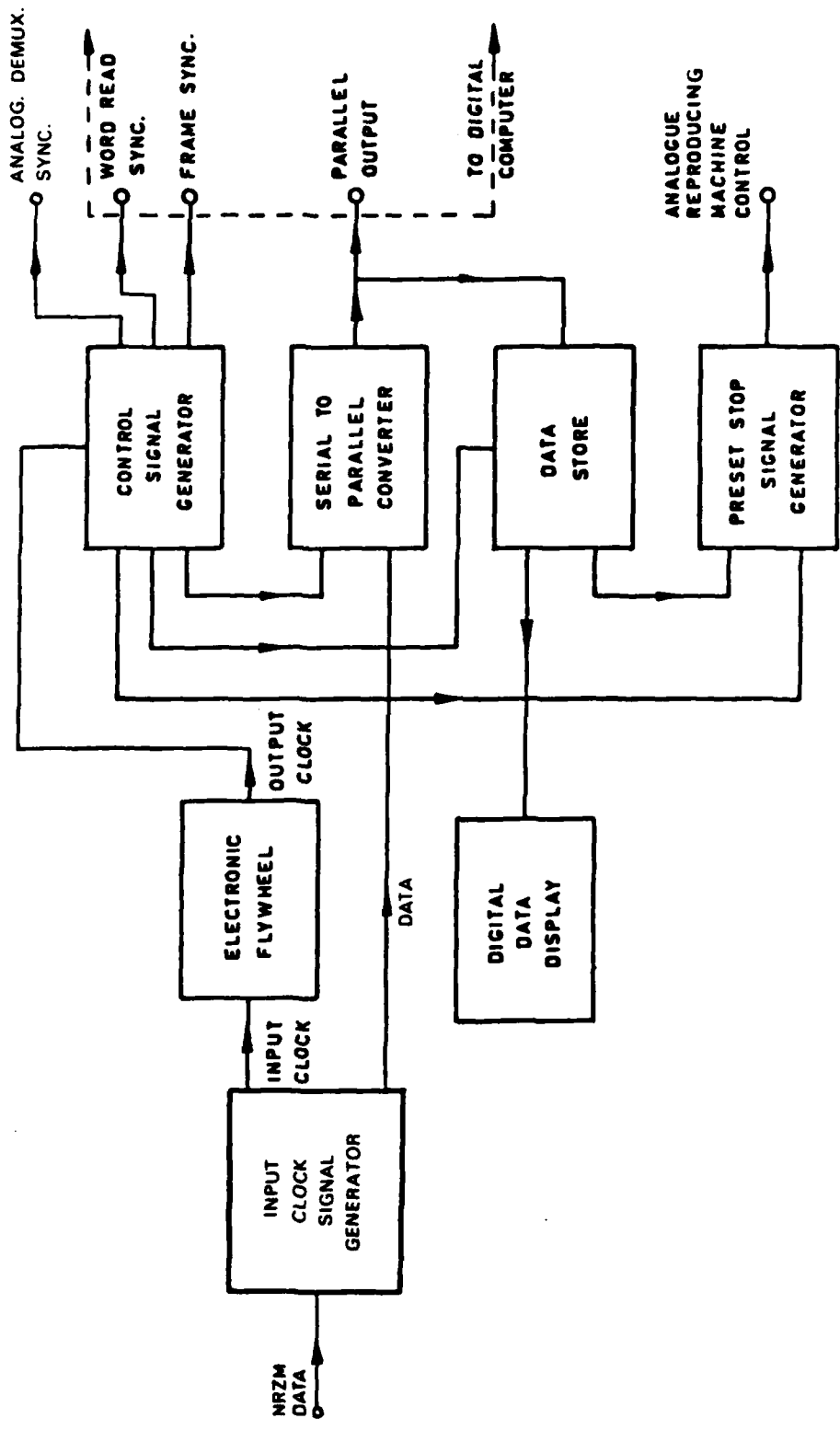

FIG. 1 BLOCK SCHEMA OF DIGITAL INTERFACE

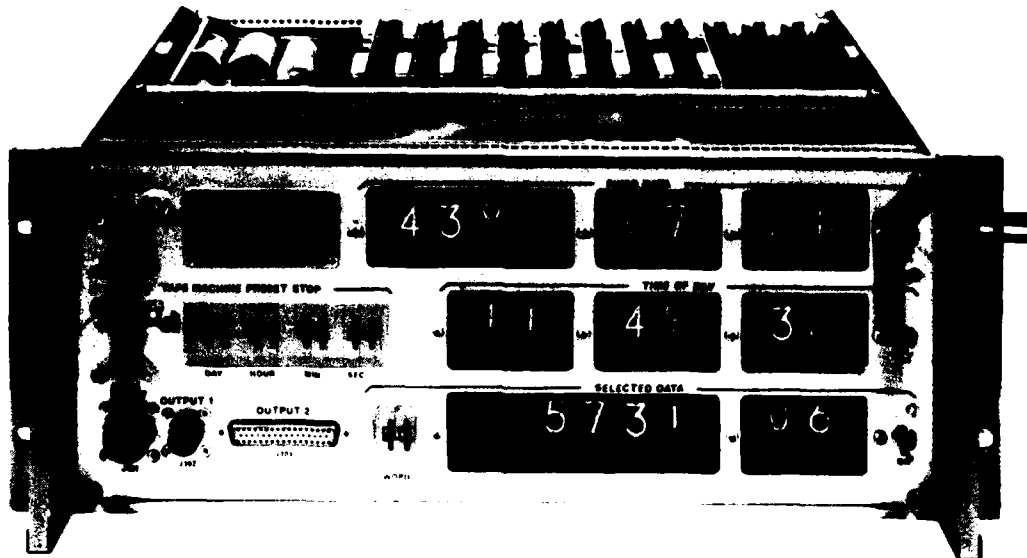

FIG. 2 FRONT VIEW OF GROUND STATION DIGITAL INTERFACE

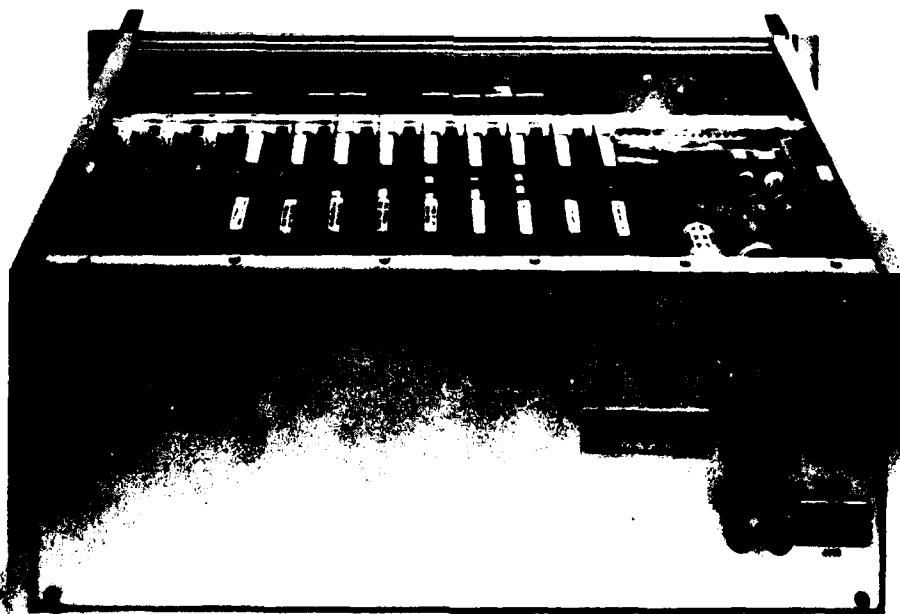

FIG. 3 REAR VIEW OF GROUND STATION DIGITAL INTERFACE

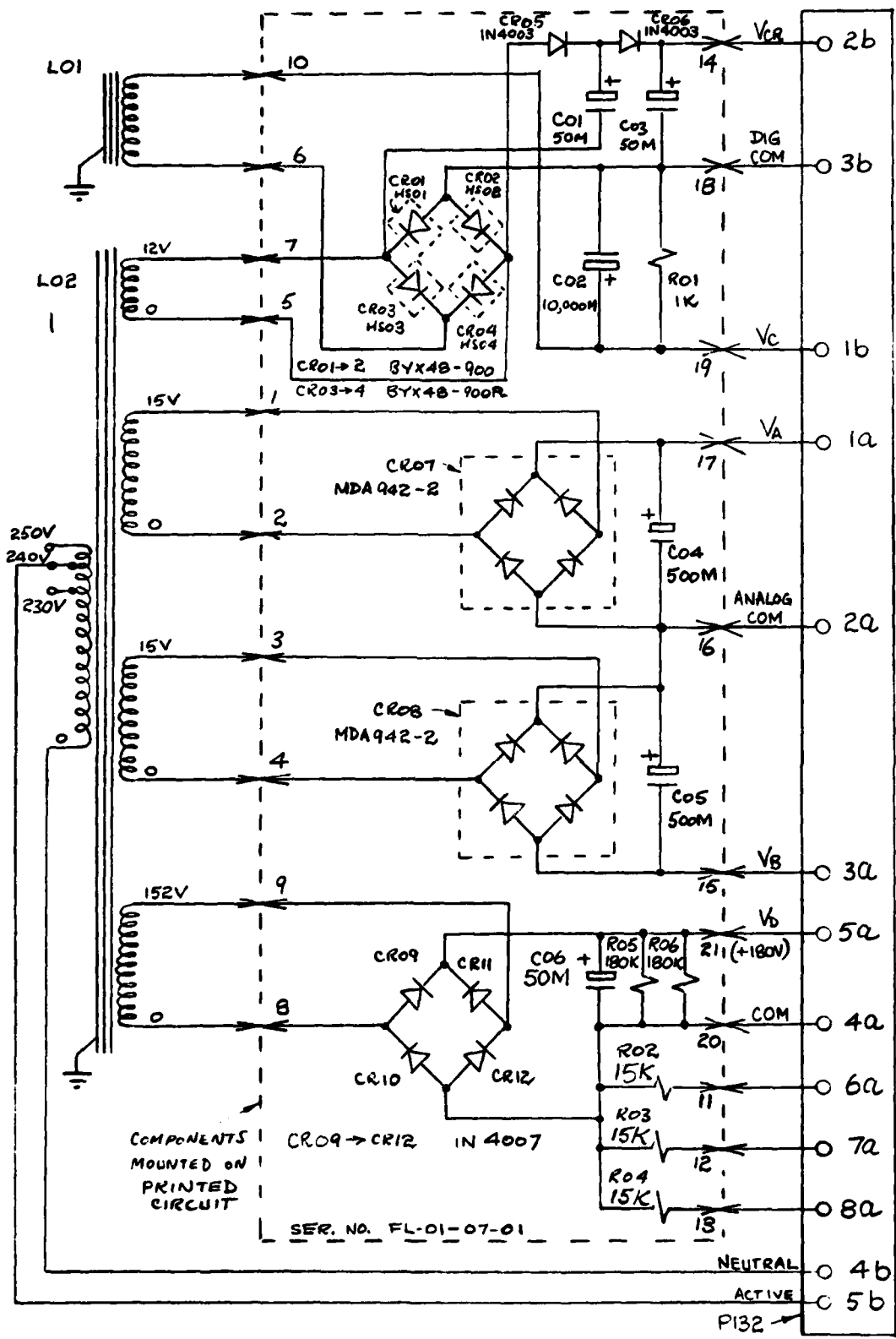

FIG. 4 AC TO DC CONVERTER

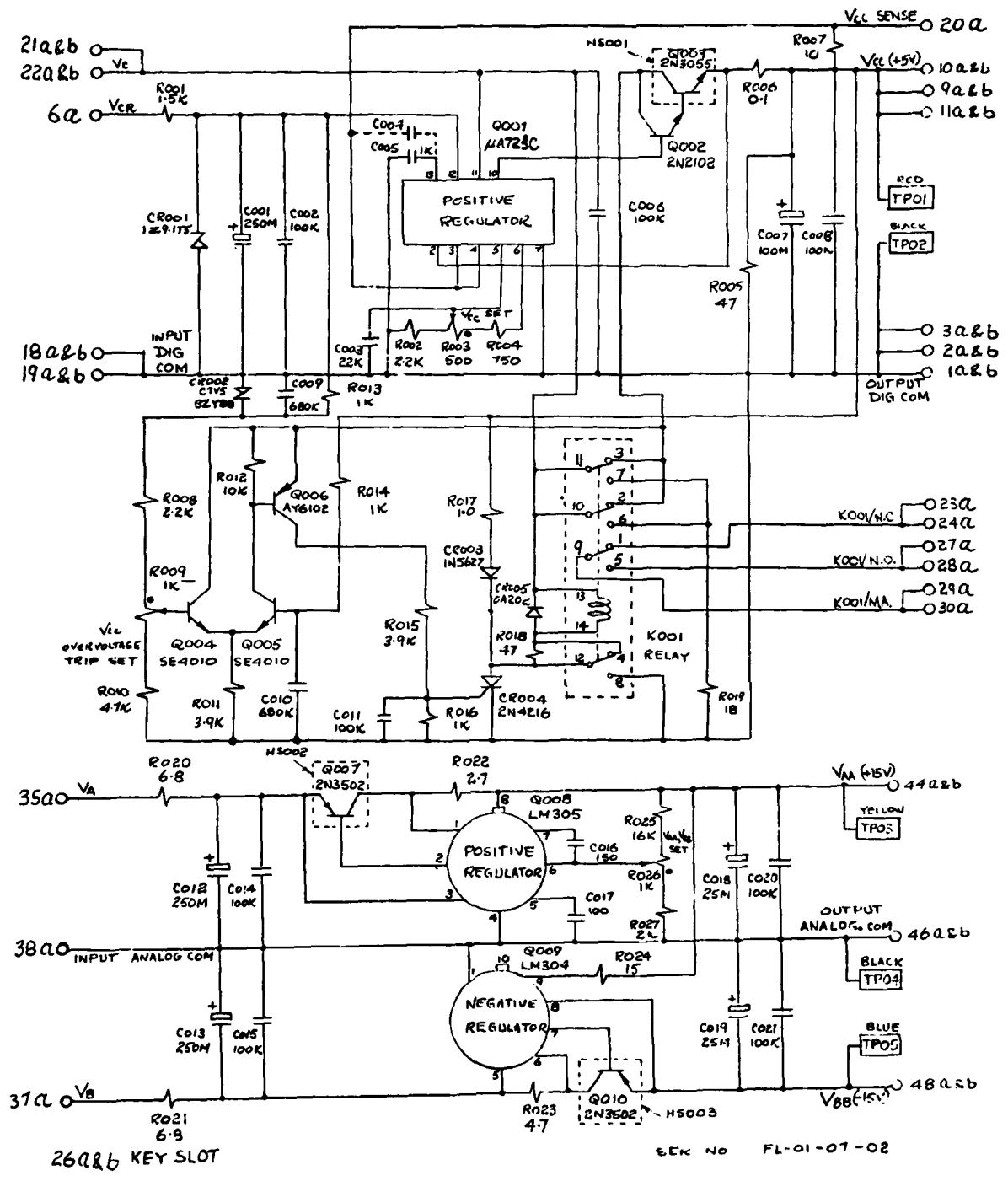

FIG. 6 VOLTAGE REGULATORS

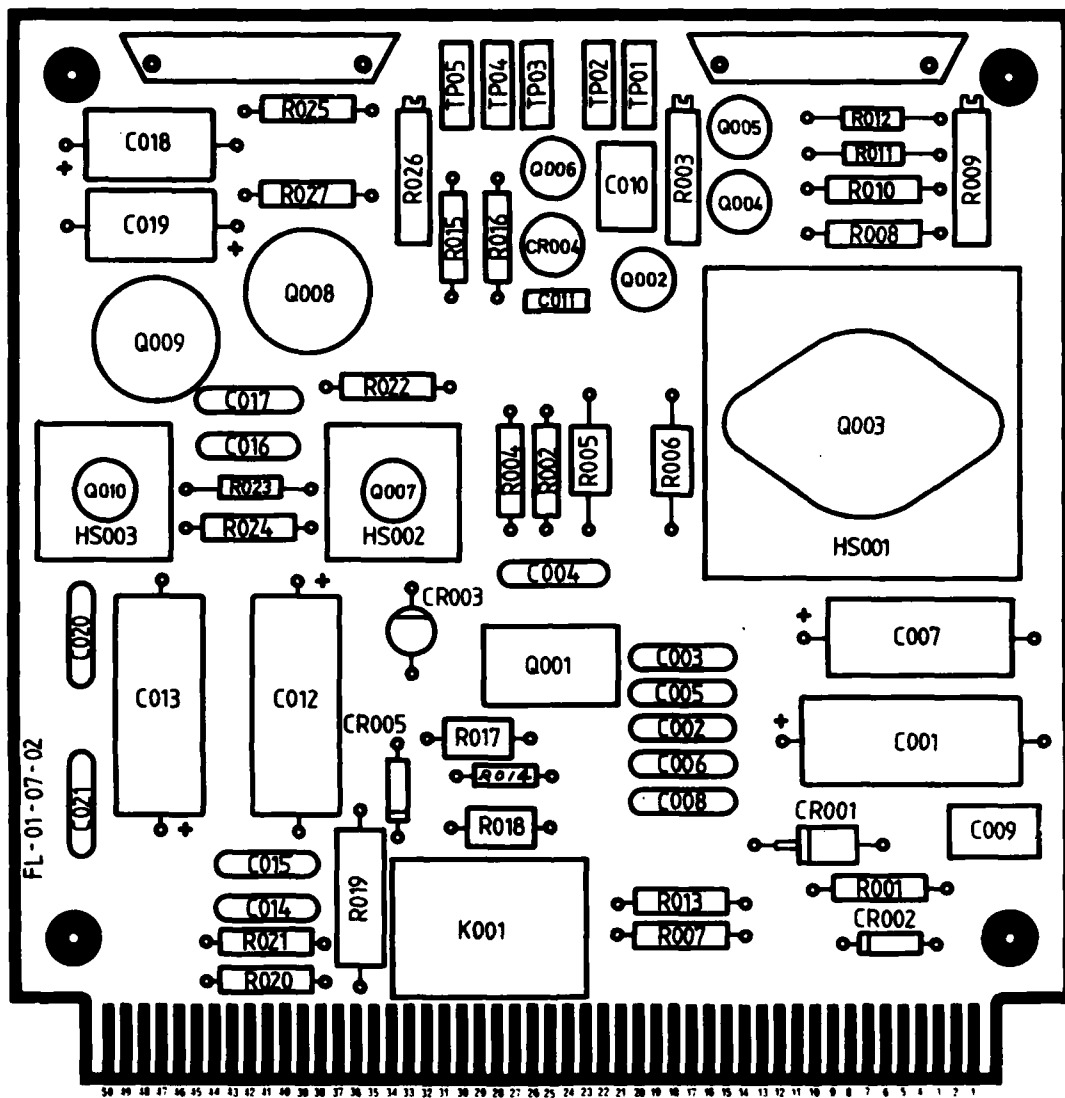
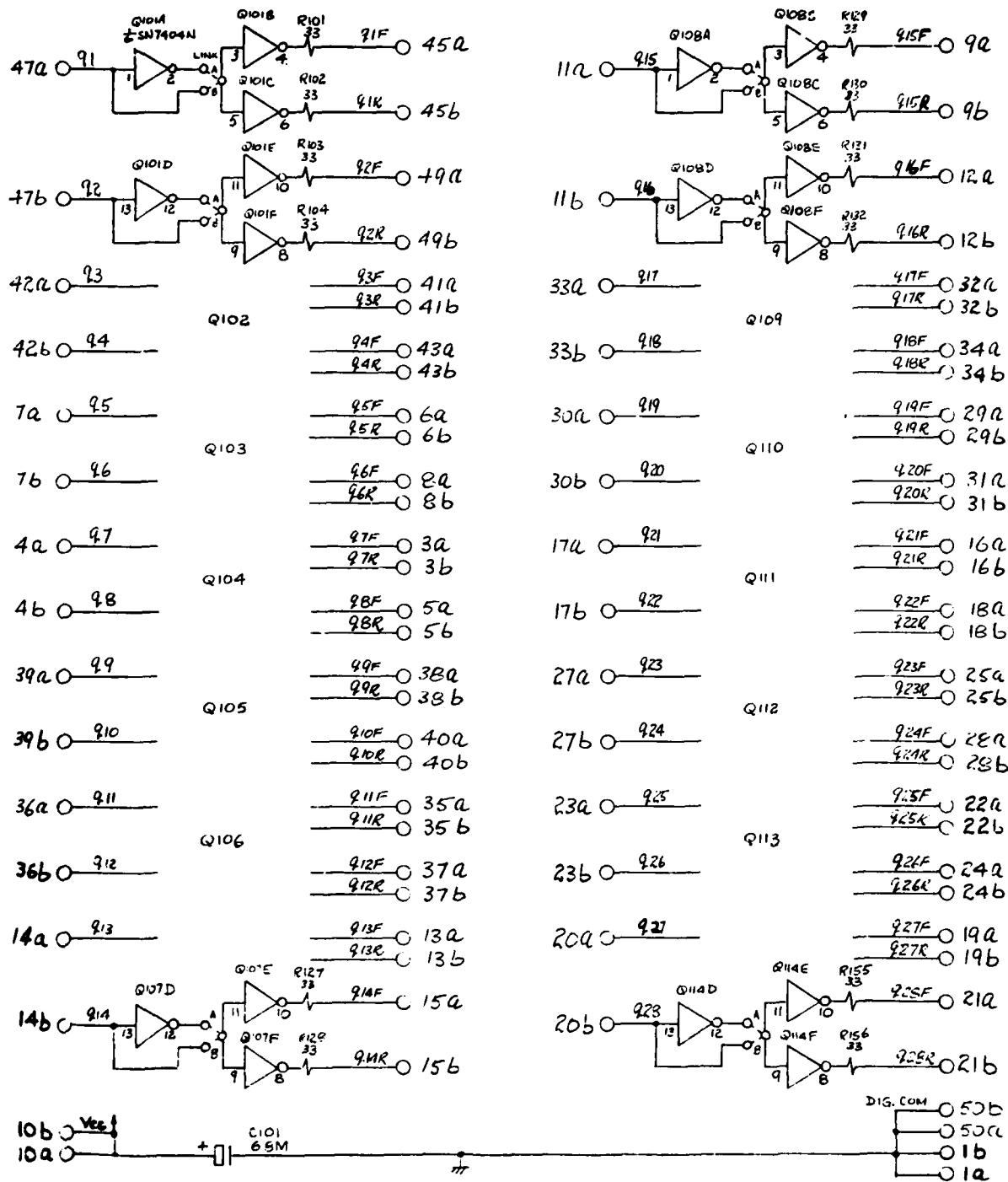

FIG. 7 COMPONENT LAYOUT FOR VOLTAGE REGULATORS



SER NO FL-01-07-03

FIG. 8 OUTPUT BUFFERS

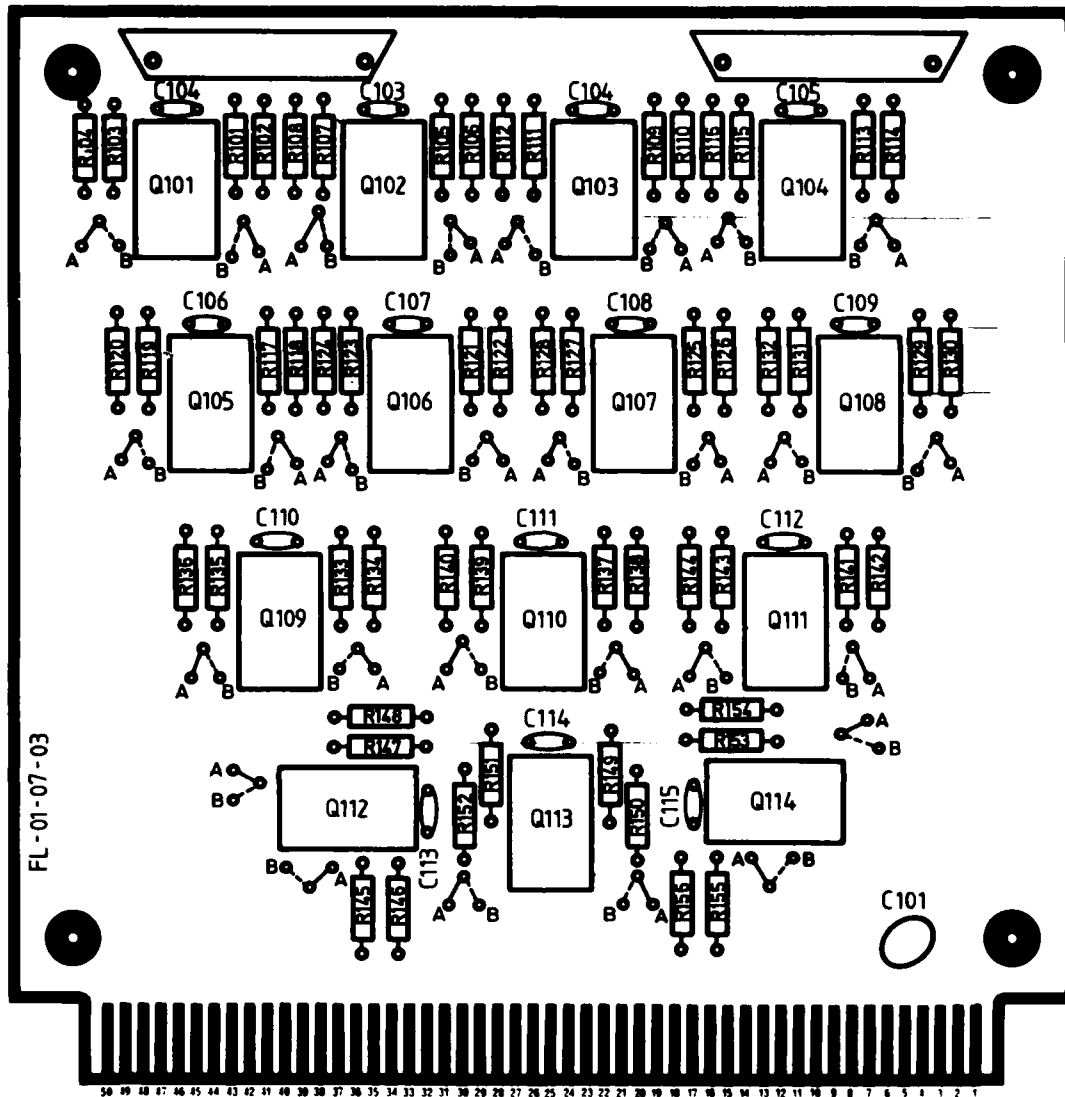

FIG. 9 COMPONENT LAYOUT FOR OUTPUT BUFFERS

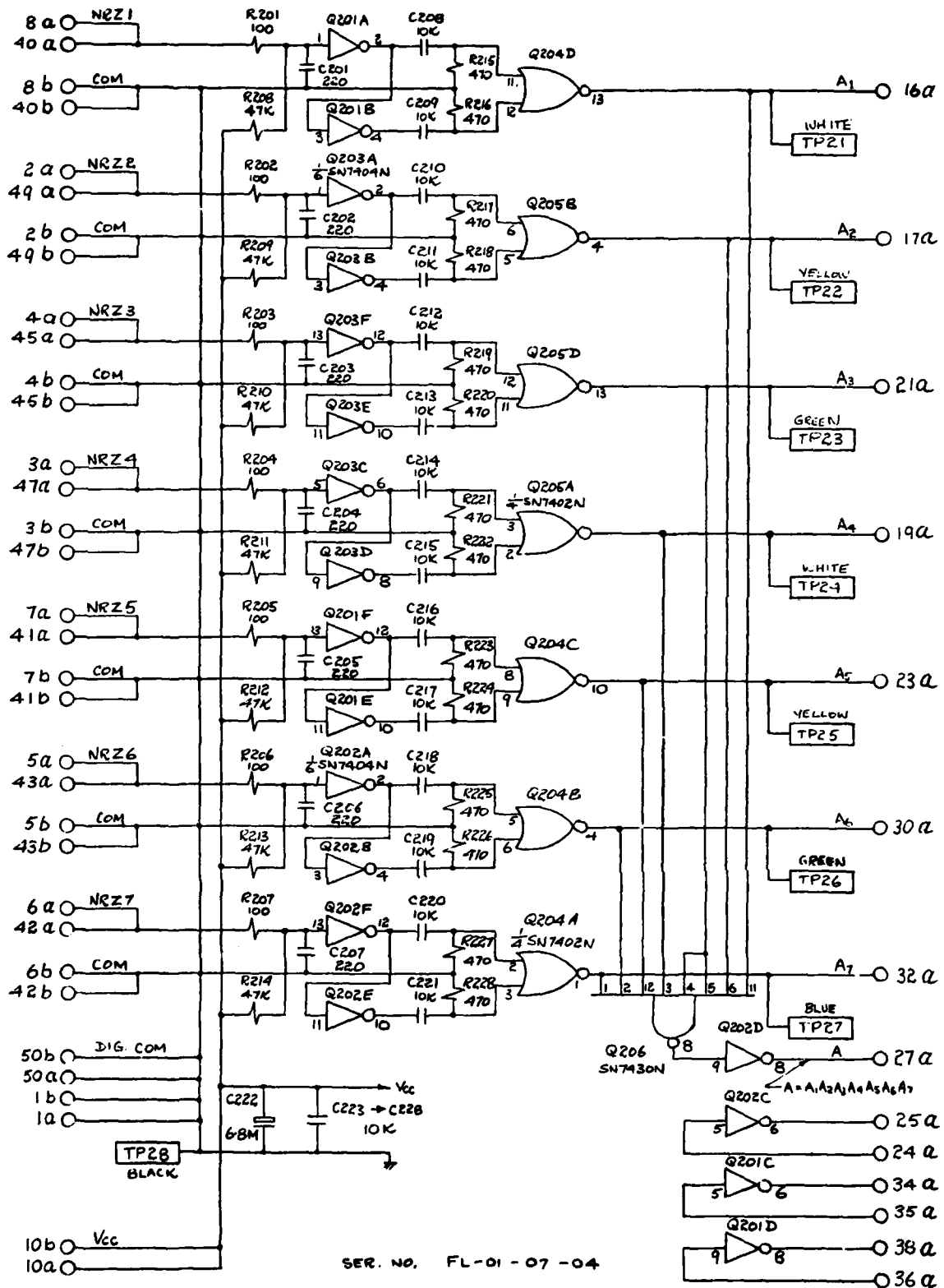

FIG. 10 INPUT CLOCK SIGNAL GENERATOR

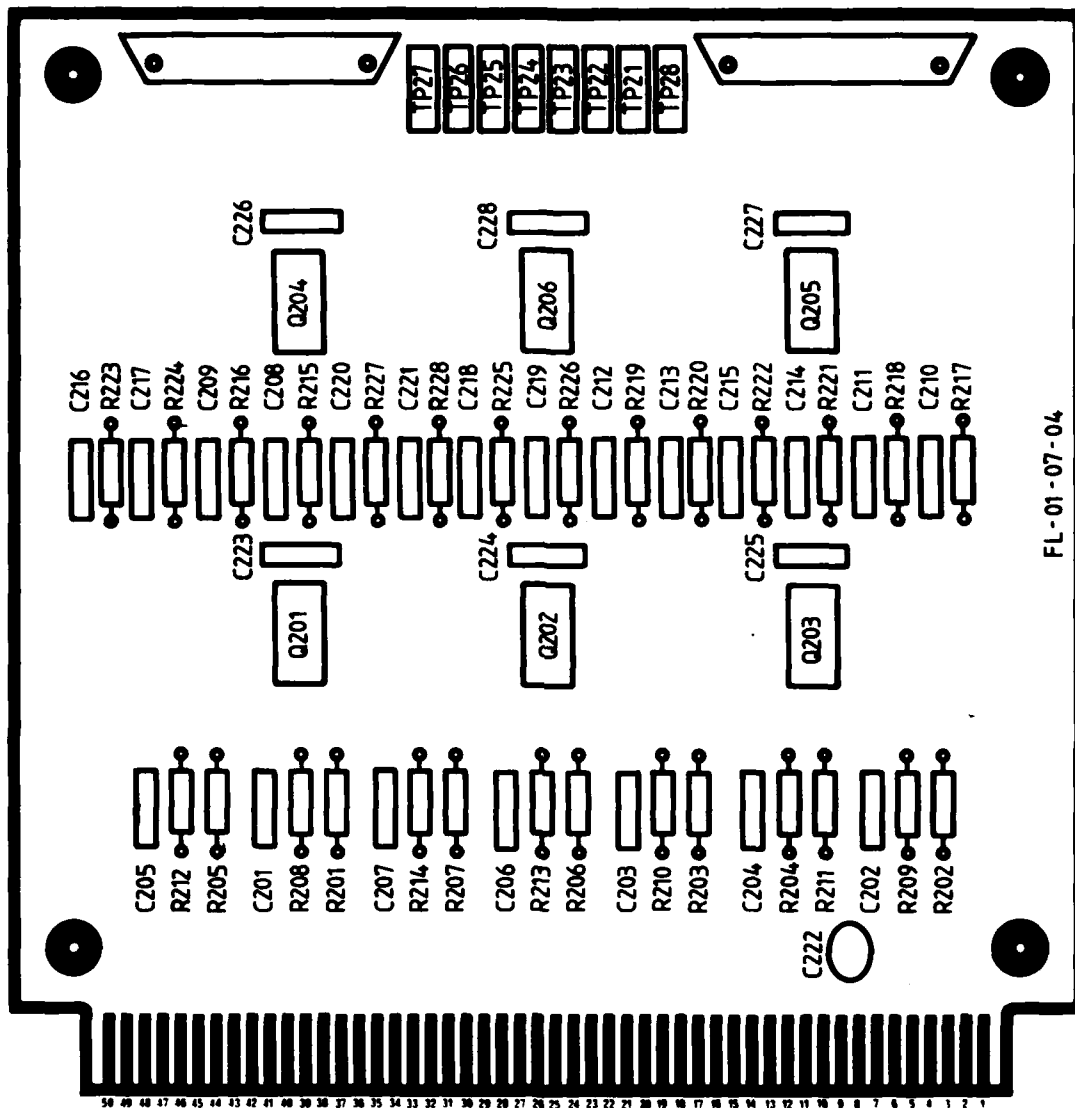
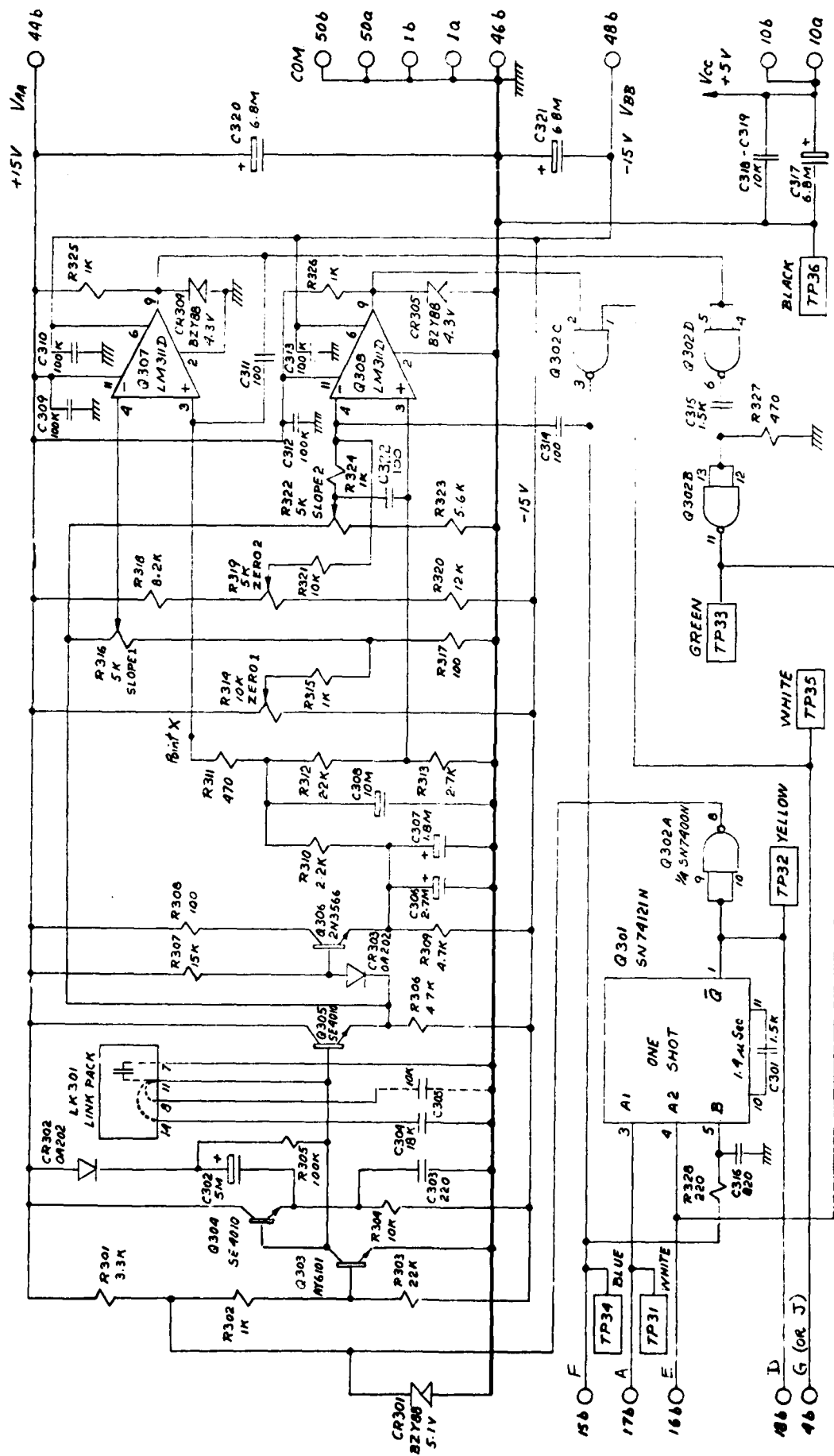

FIG. 11 COMPONENT LAYOUT FOR INPUT CLOCK SIGNAL GENERATOR



50r A/2 FL-01-07-05

FIG. 12 ELECTRONIC FLYWHEEL

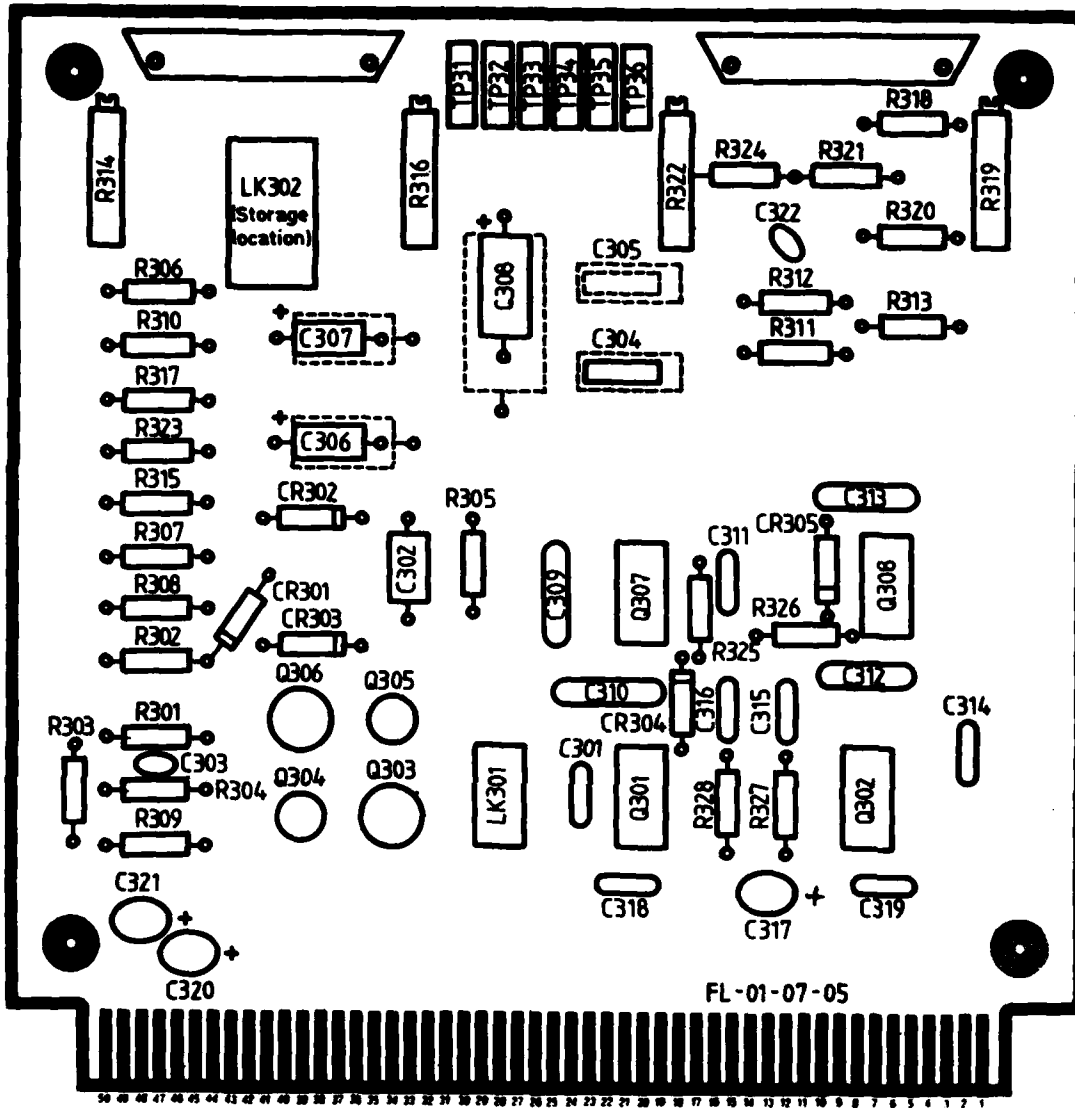

FIG. 13 COMPONENT LAYOUT FOR ELECTRONIC FLYWHEEL

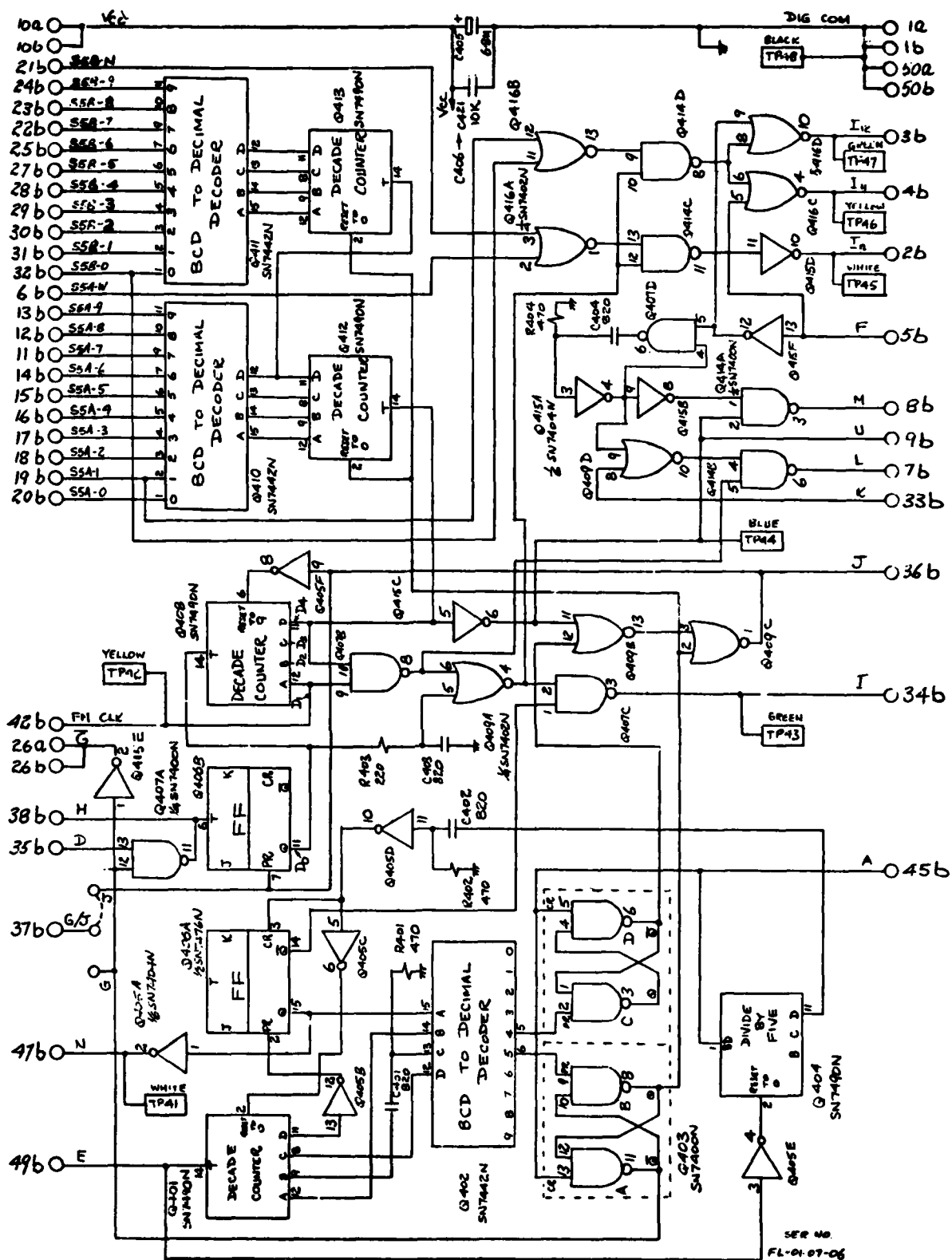

FIG. 14 CONTROL SIGNAL GENERATOR FOR SERIAL SYSTEM

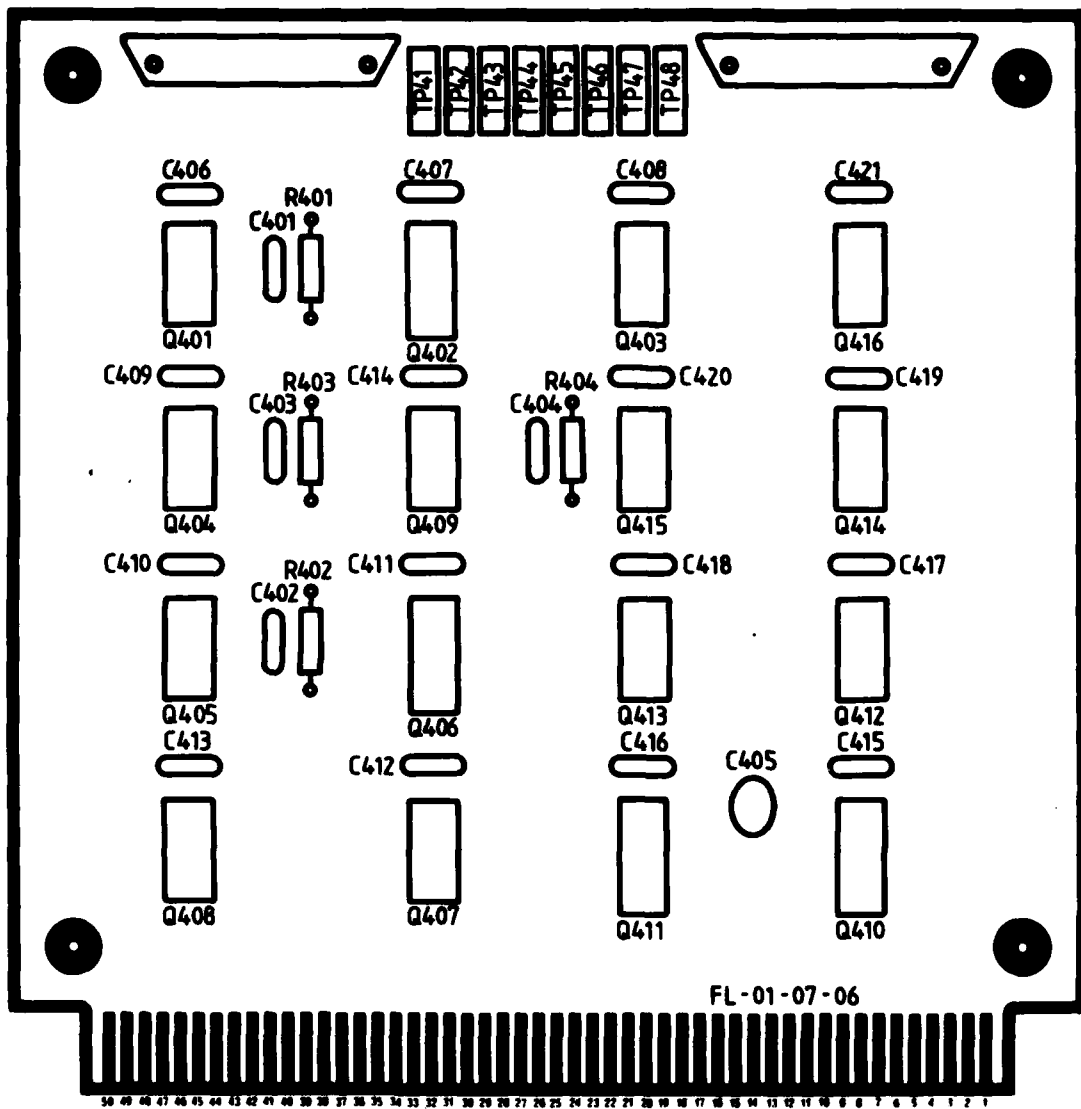

FIG. 15 COMPONENT LAYOUT FOR CONTROL SIGNAL GENERATOR FOR SERIAL SYSTEM

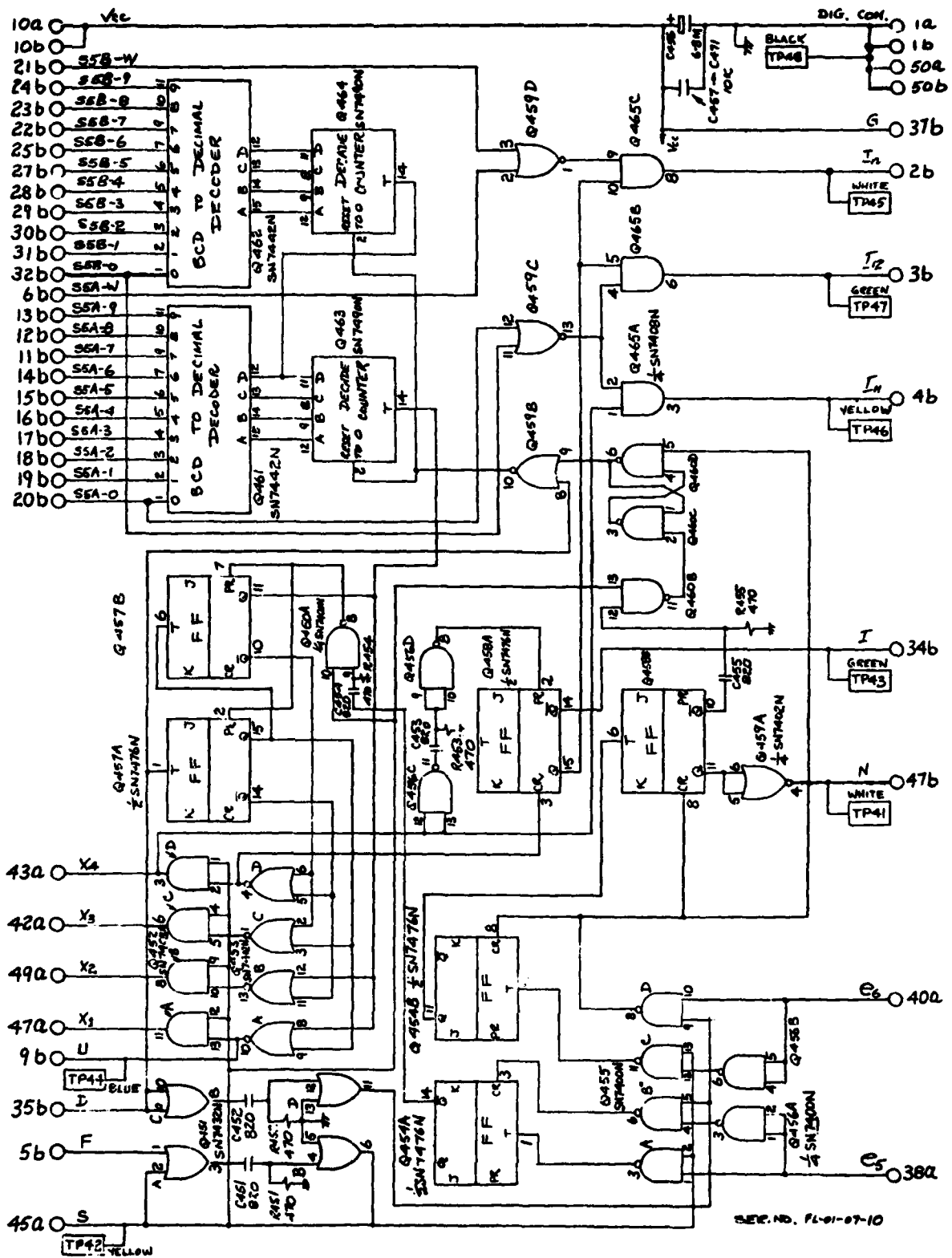

FIG. 18 CONTROL SIGNAL GENERATOR FOR PARALLEL SYSTEM

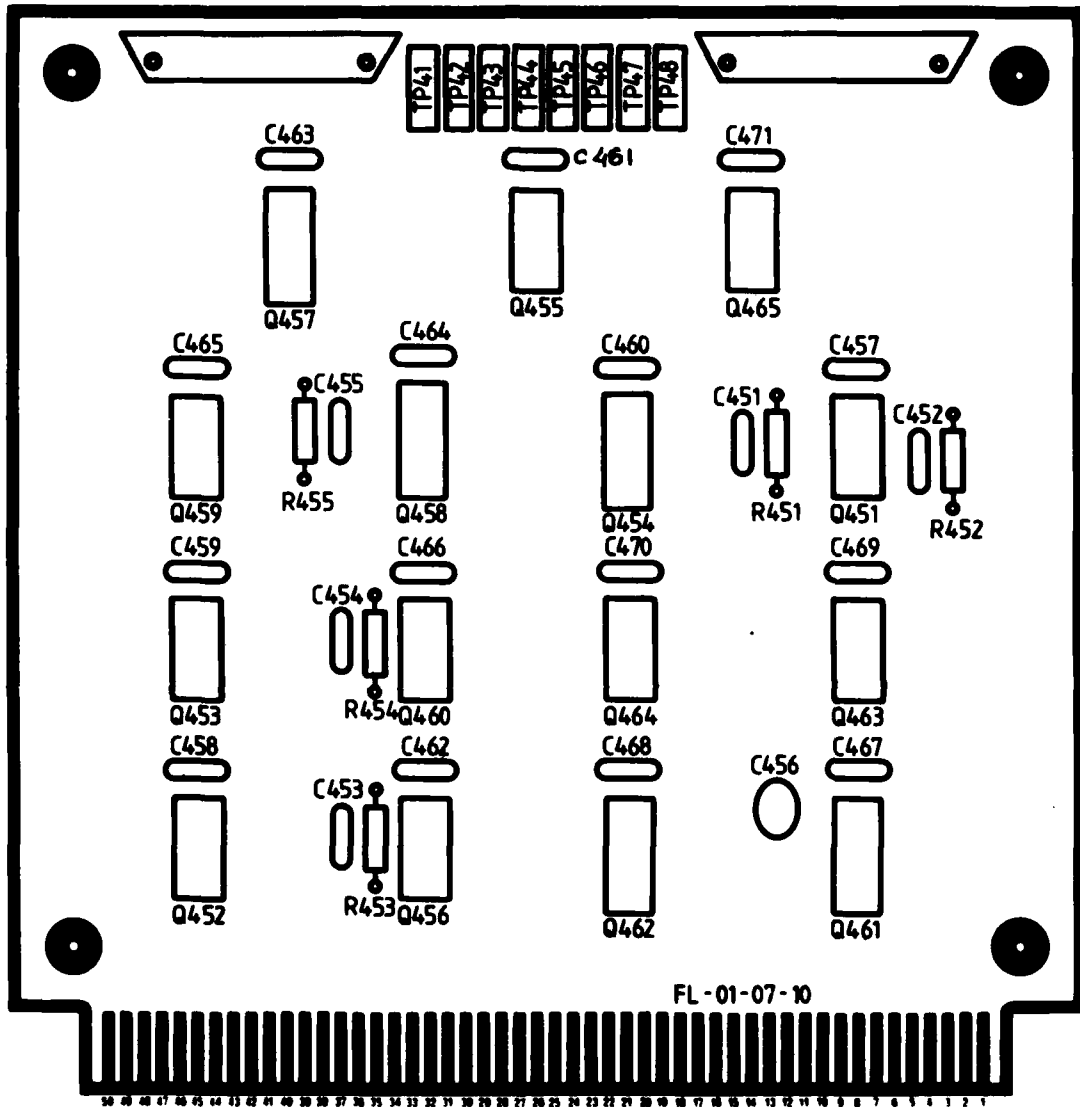
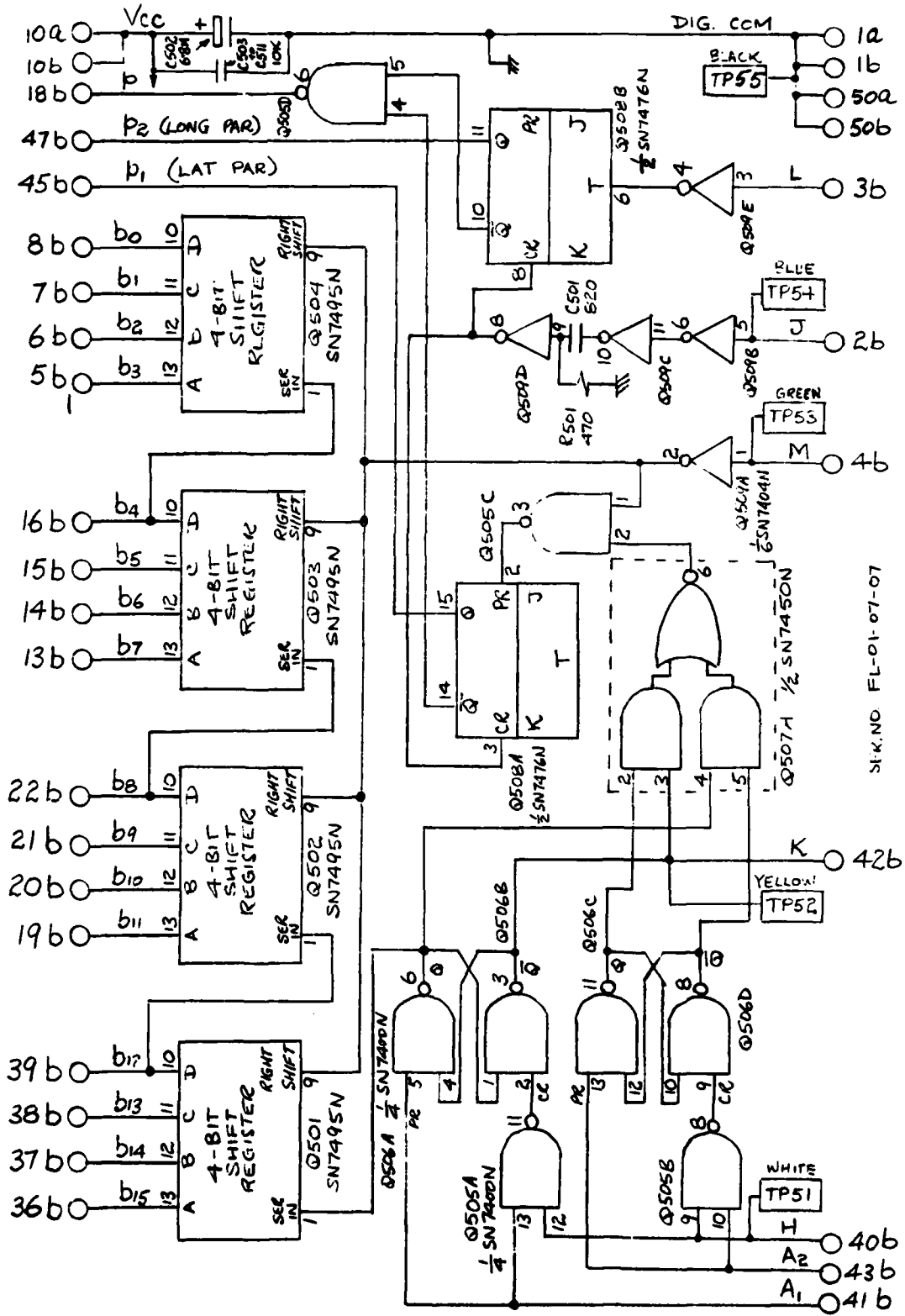

FIG. 17 COMPONENT LAYOUT FOR CONTROL SIGNAL GENERATOR FOR PARALLEL SYSTEM



SI.K.NO. FL-01-07-07

FIG. 18 SERIAL TO PARALLEL CONVERTER FOR SERIAL SYSTEM

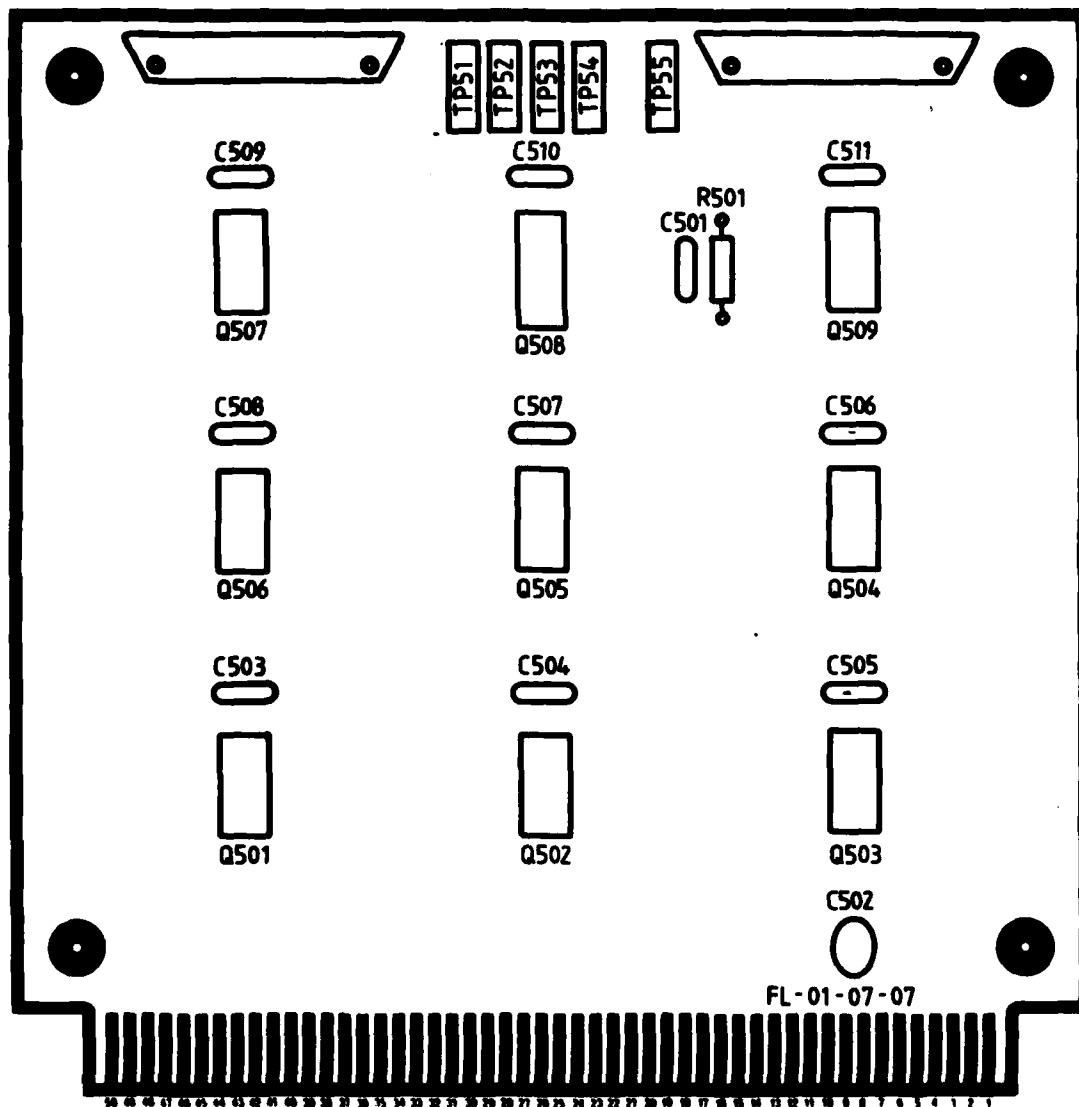

FIG. 19 COMPONENT LAYOUT FOR SERIAL TO PARALLEL CONVERTER FOR SERIAL SYSTEM

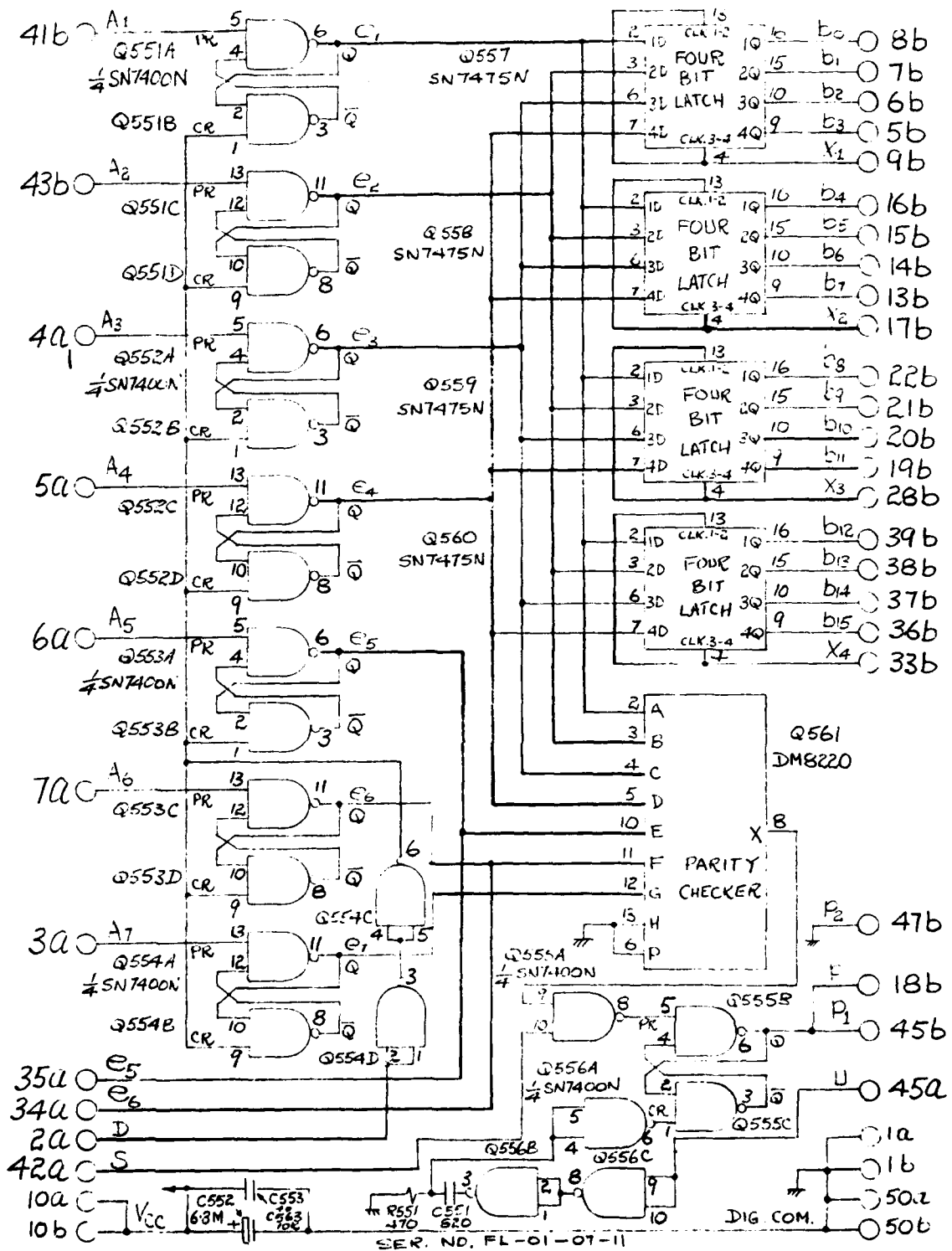

FIG. 20 SERIAL TO PARALLEL CONVERTER FOR PARALLEL SYSTEM

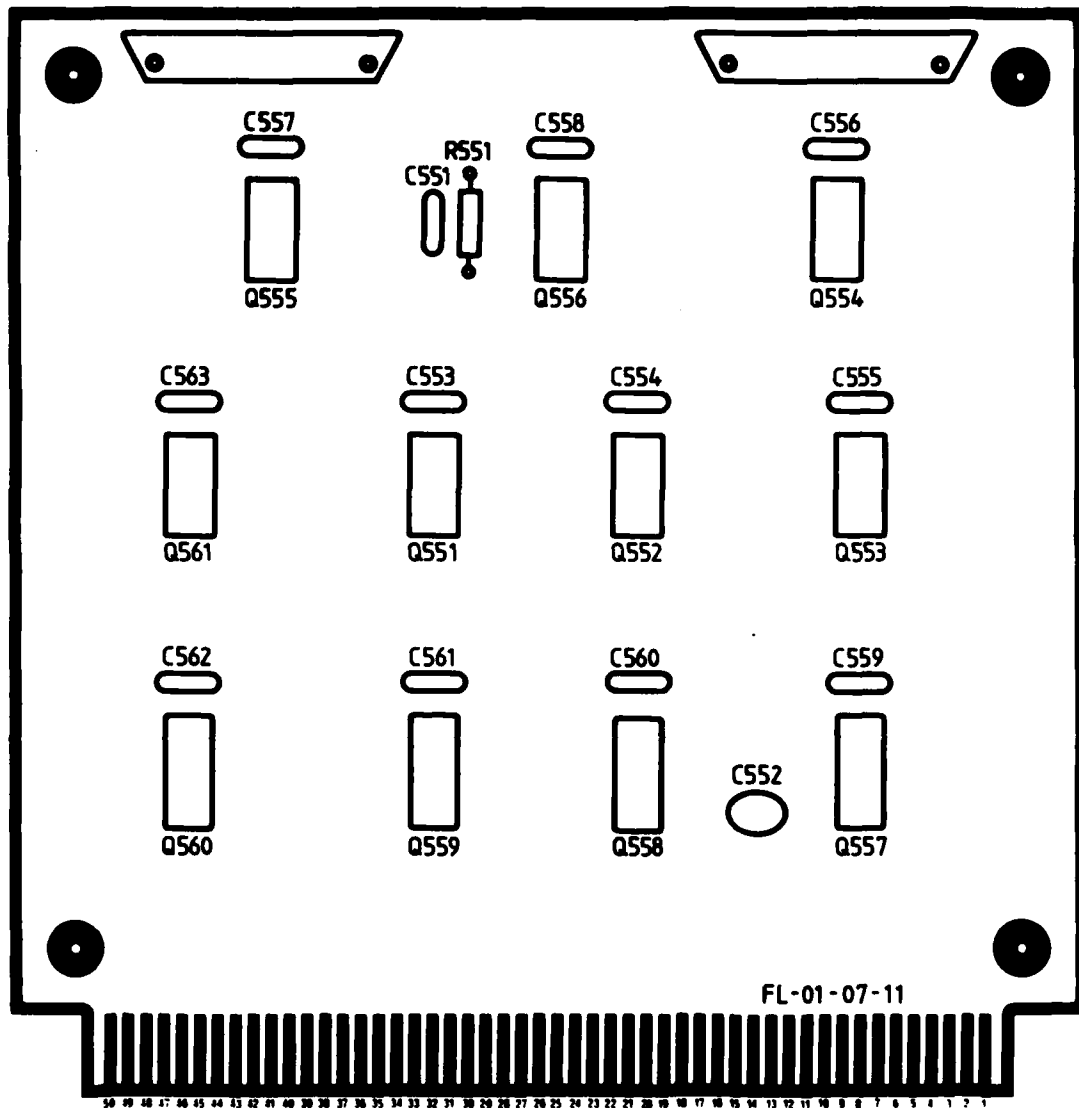

FIG. 21 COMPONENT LAYOUT FOR SERIAL TO PARALLEL CONVERTER FOR PARALLEL SYSTEM

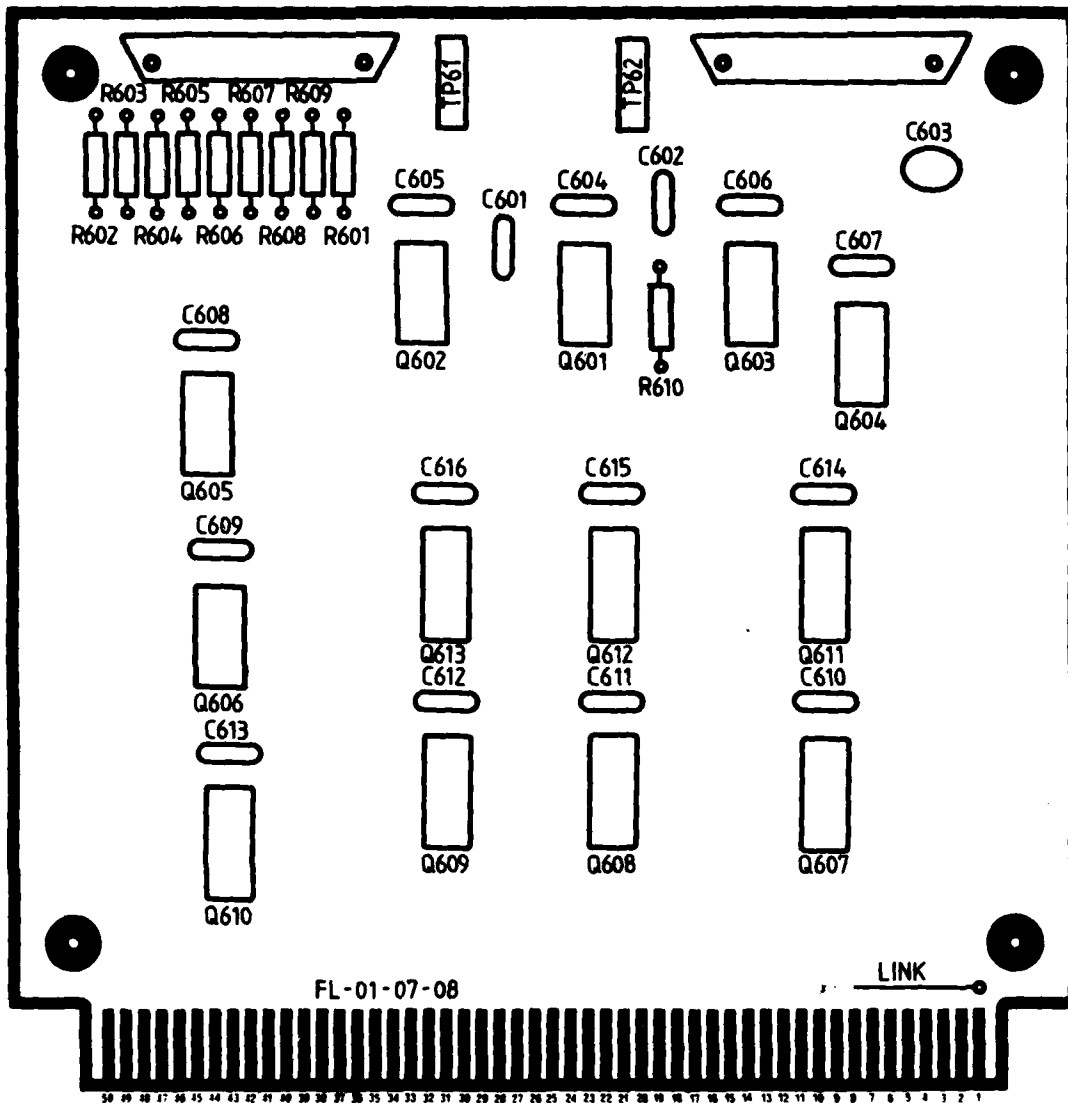

FIG. 23 COMPONENT LAYOUT FOR TIME-OF-DAY STORE AND PRESET-STOP GENERATOR

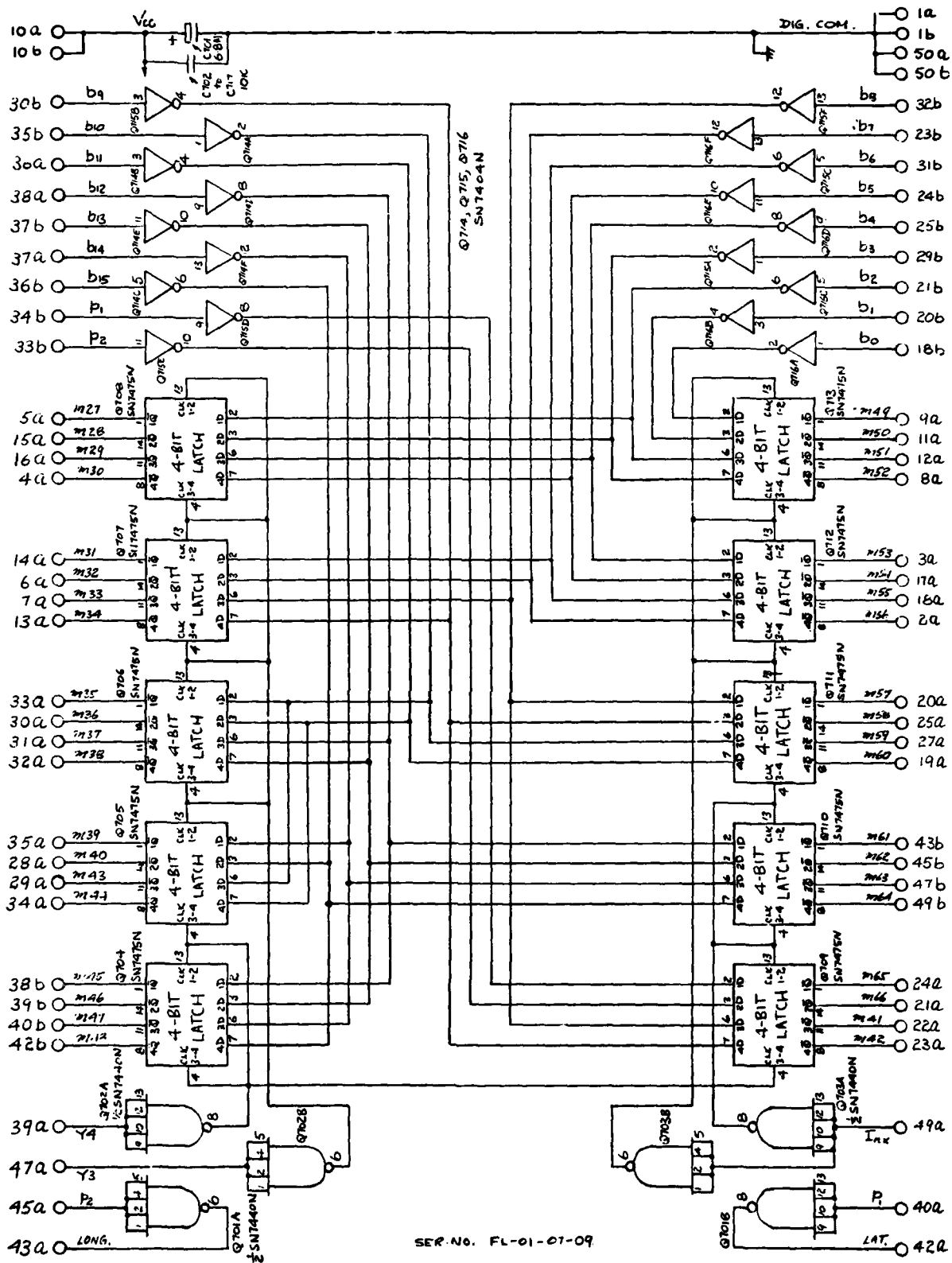

FIG. 24 SELECTED DATA AND FIXED DATA STORE

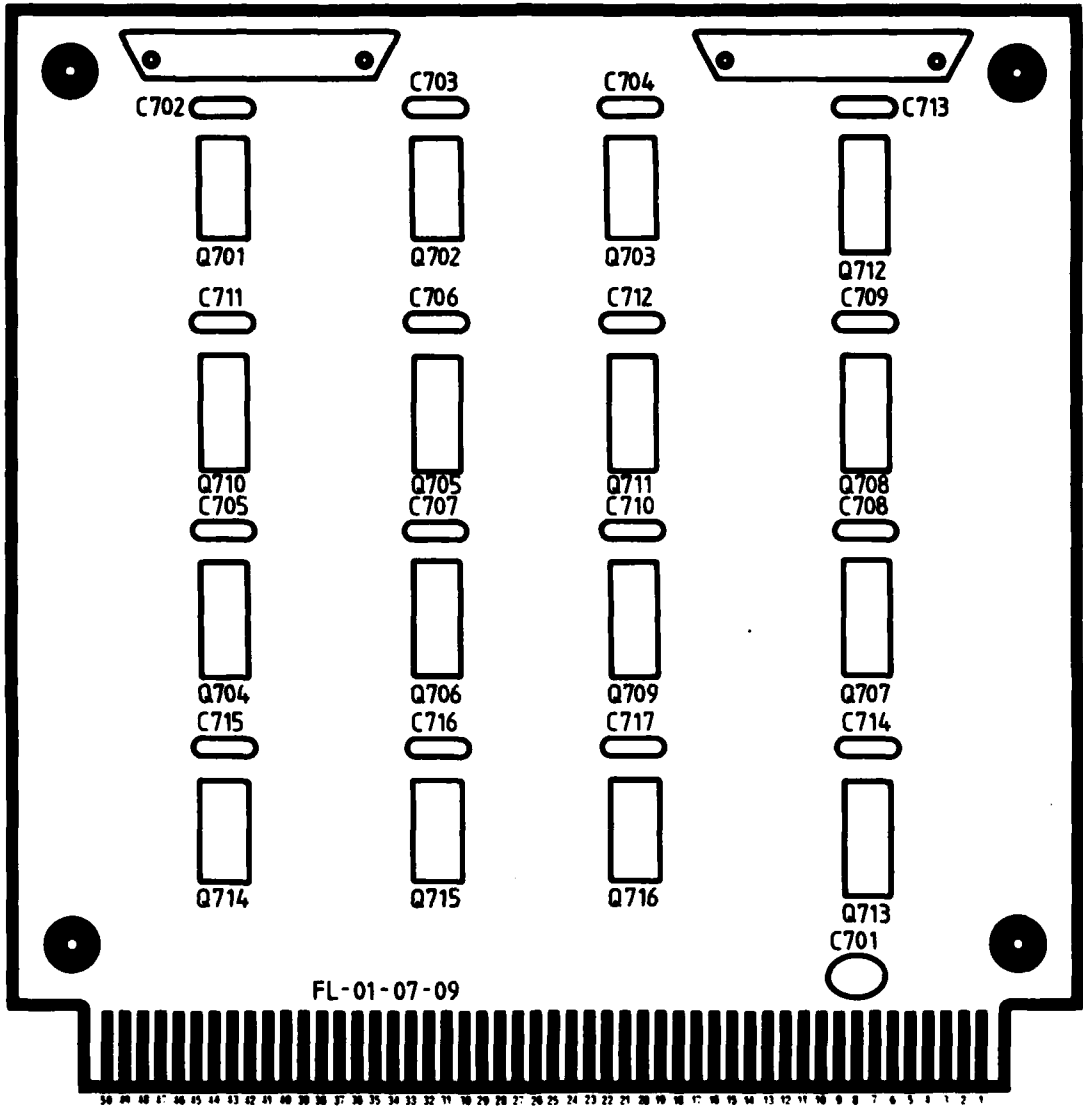
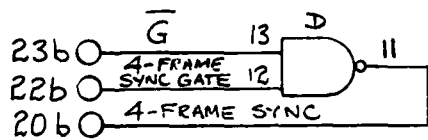
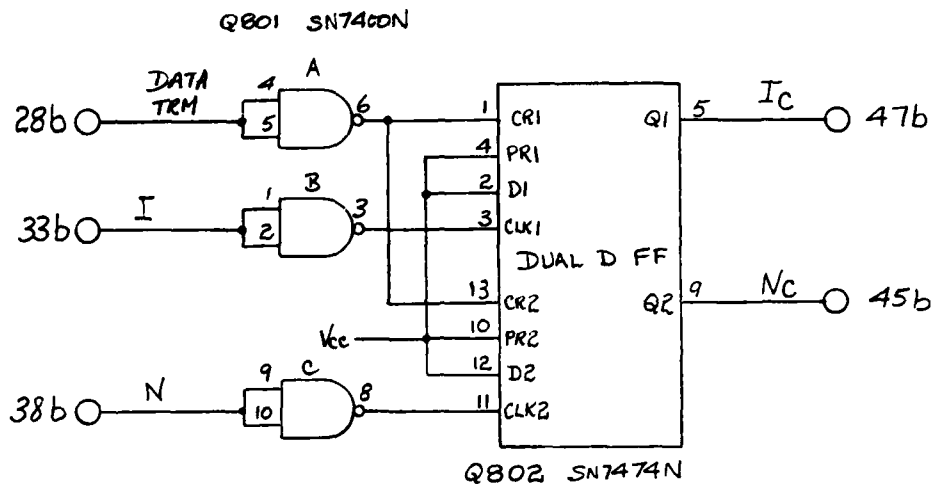

FIG. 25 COMPONENT LAYOUT FOR SELECTED DATA AND FIXED DATA STORE



SER. No. FL-01-07-12

FIG. 28 COMPUTER INTERRUPT CONTROLLER

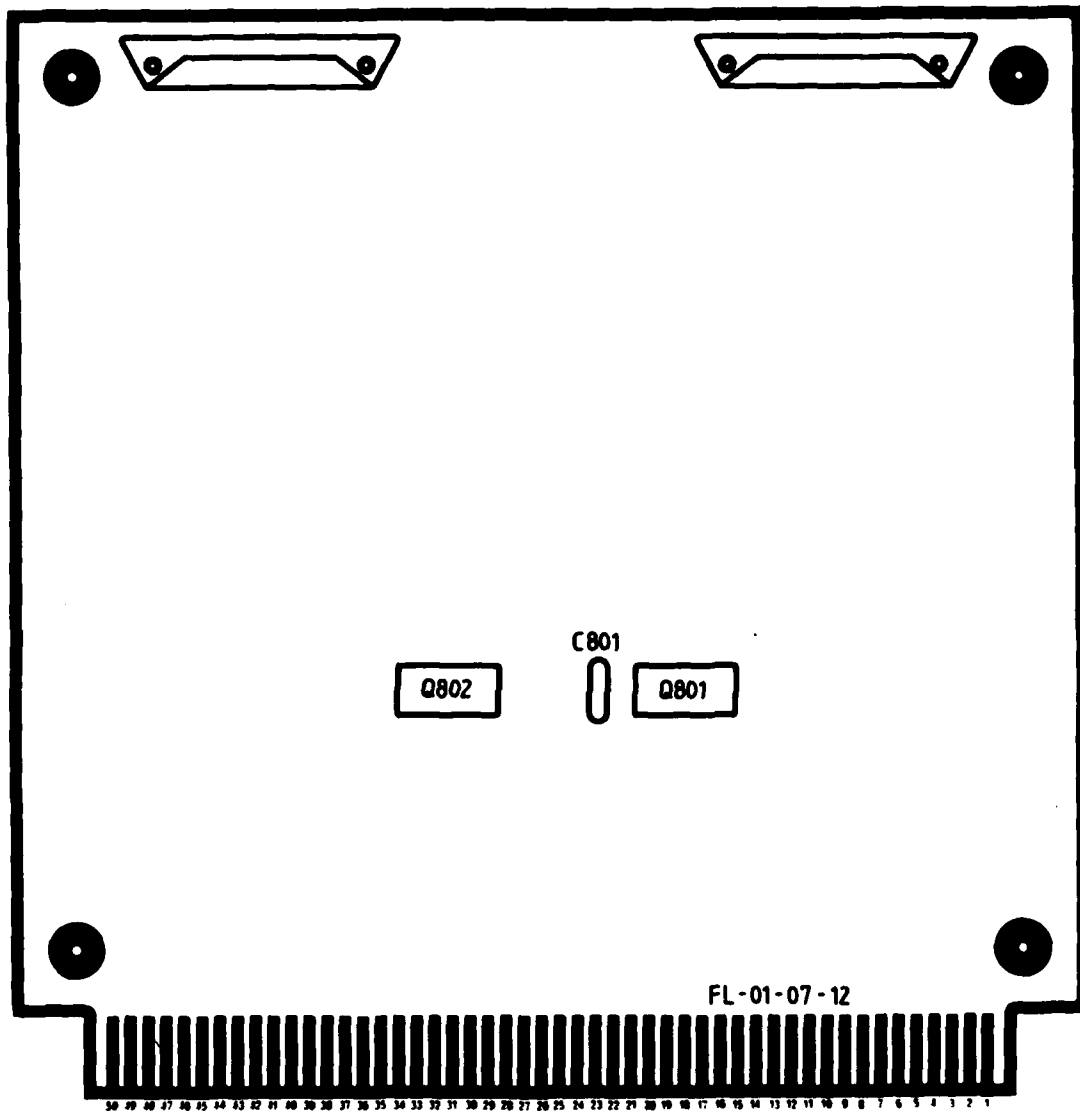

FIG. 27 COMPONENT LAYOUT FOR COMPUTER INTERRUPT CONTROLLER

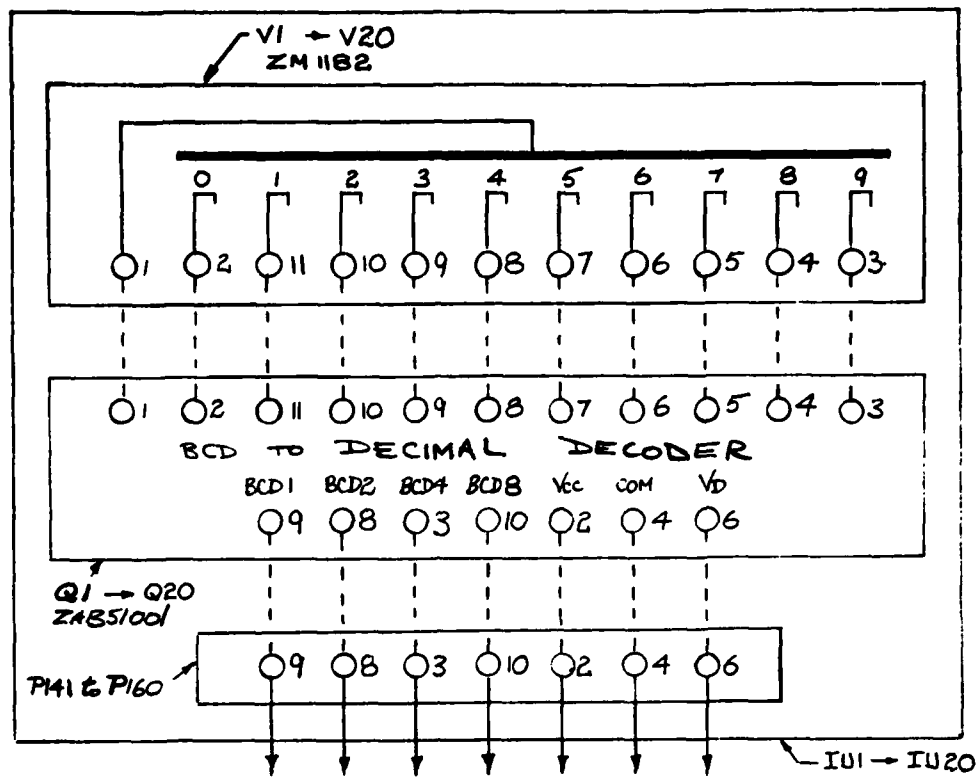

FIG. 28(a) NUMERIC INDICATOR UNIT

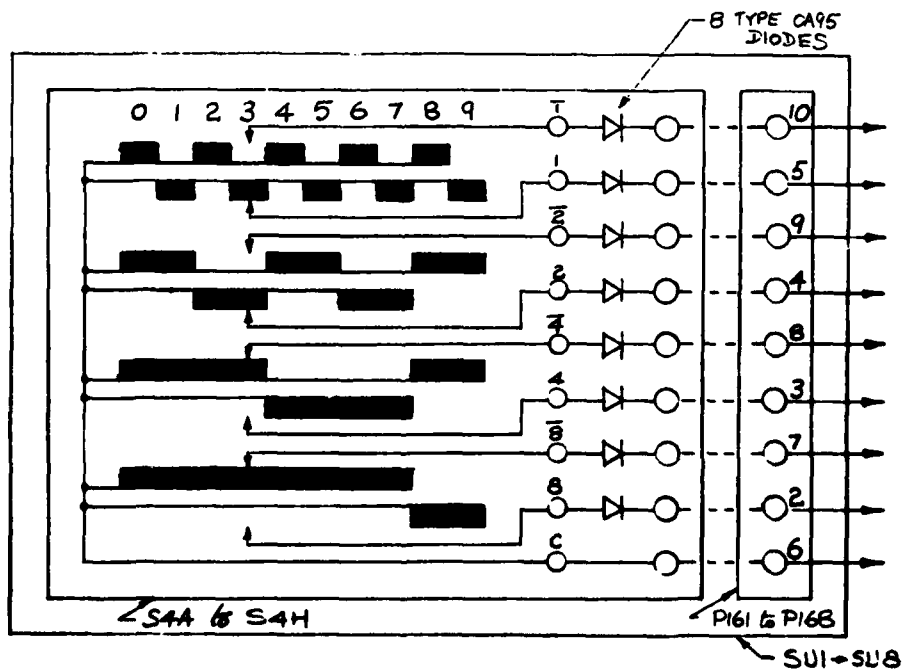

FIG. 28(b) PRESET STOP SWITCH UNIT

DISTRIBUTION

COPY NO.

AUSTRALIA

Department of Defence

Central Office

Chief Defence Scientist	1
Deputy Chief Defence Scientist	2
Superintendent, Science & Technology Programs	3
Australian Defence Scientific & Technical Representative(UK)	-
Counsellor, Defence Science (USA)	-
Joint Intelligence Organisation	4
Defence Library	5
Document Exchange Centre, D.I.S.B.	6-23
DGAD (NCO)	24-27

Aeronautical Research Laboratories

Chief Superintendent	28
Library	29
Superintendent - Mechanical Engineering Division	30
Divisional File - Mechanical Engineering	31
Author: U.R. Krieser	32
K.F. Fraser	33
PIST Group File (via U.R. Krieser)	34-35

Materials Research Laboratories

Library	36
---------	----

Defence Research Centre, Salisbury

Library	37
---------	----

SPARES

38-57

