

AD-A098 920

TECHNOLOGY SERVICE CORP SANTA MONICA CA
CONVERGENCE RATE IN ADAPTIVE ARRAYS.(U)
MAY 78 L E BRENNAN, J D MALLETT, I S REED

F/6 9/3

UNCLASSIFIED

TSC-PD-A177-5

N00019-77-C-0172

NL

1 of 1
AL A
09-9-80

END
DATE
FILMED
6-81
DTIC

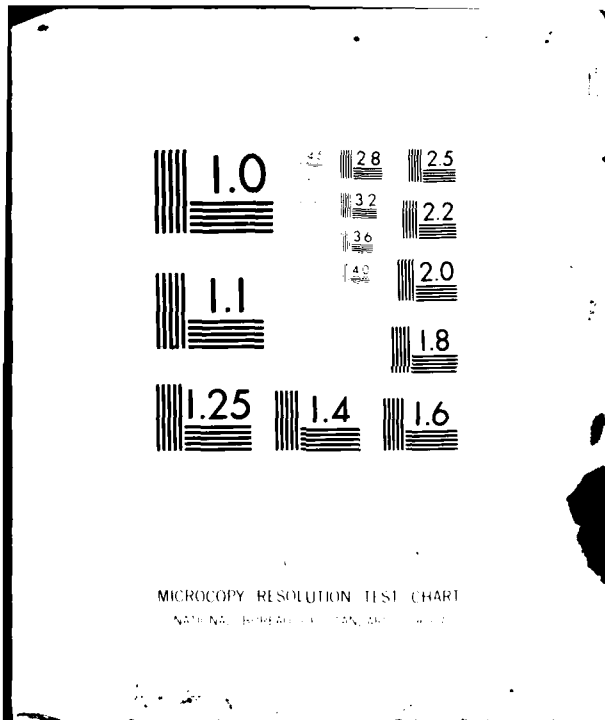

MICROCOPY RESOLUTION TEST CHART
NATIONAL BUREAU OF STANDARDS-1963-A

LEVEL II

①

5

AD A 098920

DTIC
SELECTED
S MAY 14 1981

E

DTIC FILE COPY

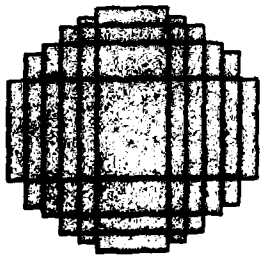

APPROVED FOR PUBLIC RELEASE
DISTRIBUTION UNLIMITED

Technology Service Corporation

81 5 13 027

*

⑥ CONVERGENCE RATE IN ADAPTIVE ARRAYS.

⑩ L. E./Brennan
J. D./Mallett
I. S./Reed

⑭ TSC-PD-A177-5

⑪ 23 May 1978

⑫ 28

⑨ Final Progress Report Submitted to the
Naval Air Systems Command on
Contract N00019-77-C-0172

⑮

DTIC
ELECTE
S MAY 14 1981 D
E

APPROVED FOR PUBLIC RELEASE
DISTRIBUTION UNLIMITED

404432

1.0 INTRODUCTION

Accession For	DTIC CR&I
	DTIC TAB
	Unannounced
	Justification

A

This is the final report on a 1 year study of convergence rate in adaptive arrays, performed under a contract from the Naval Air Systems Command. The results obtained earlier in the study are reported in three quarterly progress reports. This introductory section of the final report reviews the earlier results briefly. The remainder of this report details the results obtained during the fourth quarter of the study.

In many cases of interest, slow convergence limits the performance of adaptive array antennas. The steady state performance and transient response of an adaptive array are determined by the covariance matrix of the noise field. While the transient response is also a function of the parameters of the adaptive loops in an analog system, it is known that convergence is slow when the eigenvalues of the noise covariance matrix are widely different in value. In these cases, no choice of adaptive loop parameters can provide fast transient response and low control loop noise.^[1]

In a digital adaptive array, where the individual element outputs are A/D converted and the adaptive weights are computed using a sample covariance matrix, rapid convergence can be obtained independently of the distribution of the eigenvalues.^[2]

When the outputs of the different elements in an adaptive array are mutually independent, it is easy to achieve rapid convergence in an analog system. One method of transforming the array element outputs to

a set of independent variables is based on a transformation to normal coordinates.^[3] A simpler transformation to implement is based on the Gram-Schmidt orthogonalization. The application of a Gram-Schmidt network to adaptive arrays was suggested independently by at least three different groups working in the field, including TSC. Our interest in this subject was preceded by work by Girandau^[4] and others.

A self-orthogonalizing network which transforms the set of array element outputs $\{x_{1k}\}$ to a set of independent variables $\{z_k\}$ is illustrated in Fig. 1. The outputs $\{z_k\}$ can be equalized in power using automatic gain control (ACG) and followed by any desired type of adaptive array, including the pilot signal and power inversion arrays of primary interest in communications. It was shown in the first quarterly progress report that the outputs z_k are independent. The network of Fig. 1 is a power inversion array, the desired output being z_N .

Each node in the network has two inputs, x_{kk} and x_{kn} , and generates an adaptively controlled weight w_{kn} . The output of a node is

$$x_{k+1,n} = x_{kn} - w_{kn} x_{kk} \quad (1)$$

The weights approach steady state values of

$$w_{kn} = \frac{x_{kk}^* x_{kn}}{|x_{kk}|^2} \quad (2)$$

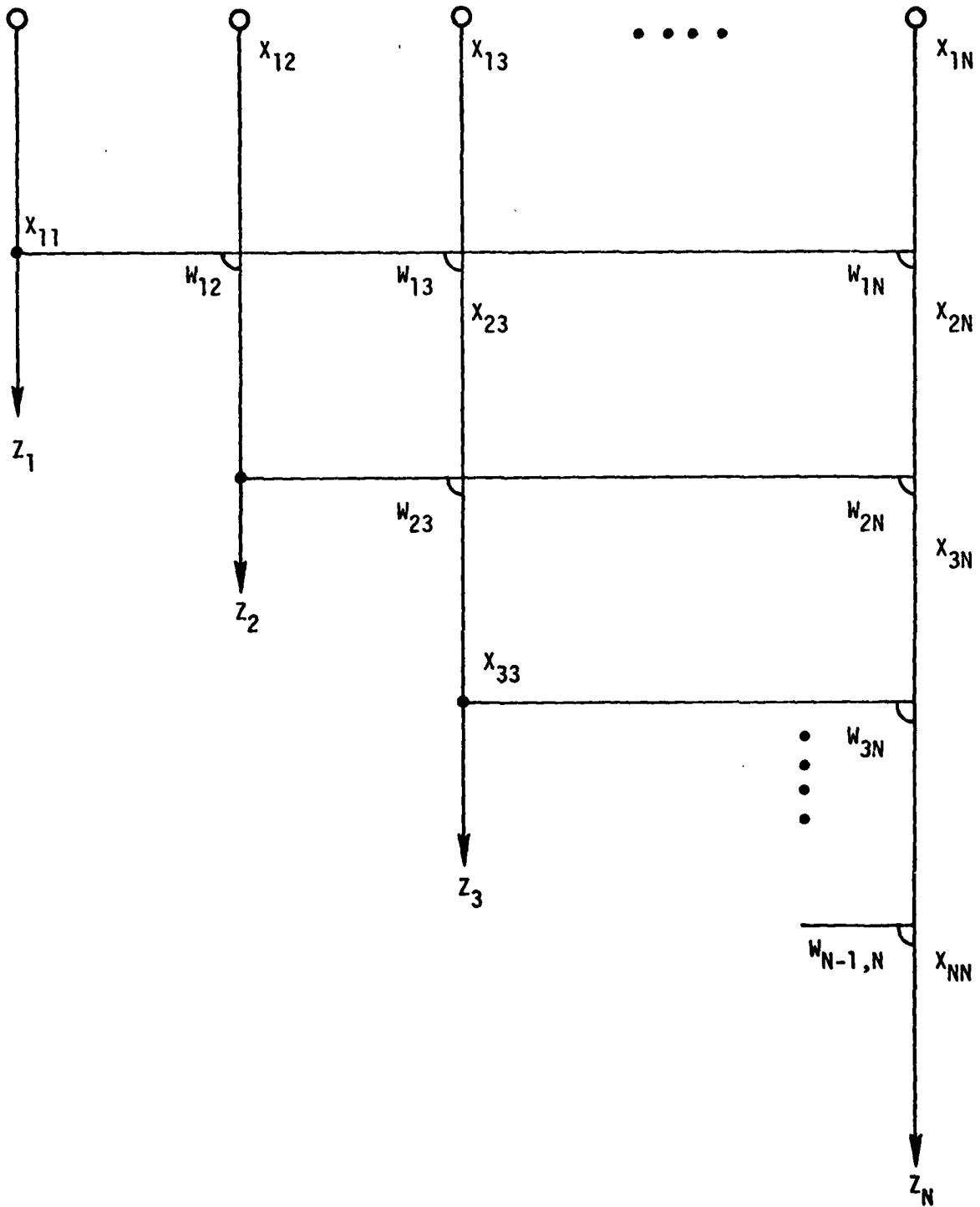

Figure 1. Adaptive Self-Orthogonalizing Network Based on Gram-Schmidt

Analog circuits for generating the adaptive weights are illustrated in Fig. 2.

Simulation results are shown in Figs. 3 and 4 which illustrate the large improvement in convergence rate achievable with the self-orthogonalizing networks. The same 3 element array and 2 unequal interference sources were simulated in both cases. A conventional 3 element power inversion array with 2 adaptive weights was used in the simulation of Fig. 3. Much faster convergence was obtained with the self-orthogonalizing network of 3 adaptive weights as shown in Fig. 4. Examples showing very rapid convergence with the Gram-Schmidt network - convergence in N samples with an $N+1$ element array - are also contained in the first quarterly report. The theory of these rapidly converging systems, relating the sample covariance matrix and Gram-Schmidt solutions, is discussed in the first report.

The second and third quarterly reports, and the remainder of this report, deal with control loop (weight jitter) noise in the self-orthogonalizing networks. The second quarterly report applies Tikhonov's method to the problem and contains some approximate solutions for the first and second moments of the weights in these networks. A solution for the 3 element array, a self-orthogonalizing network containing 3 weights, based on a first order perturbation theory, is contained in the third quarterly report. The third report also discusses the differential equations describing the transient response of a 3 element network.

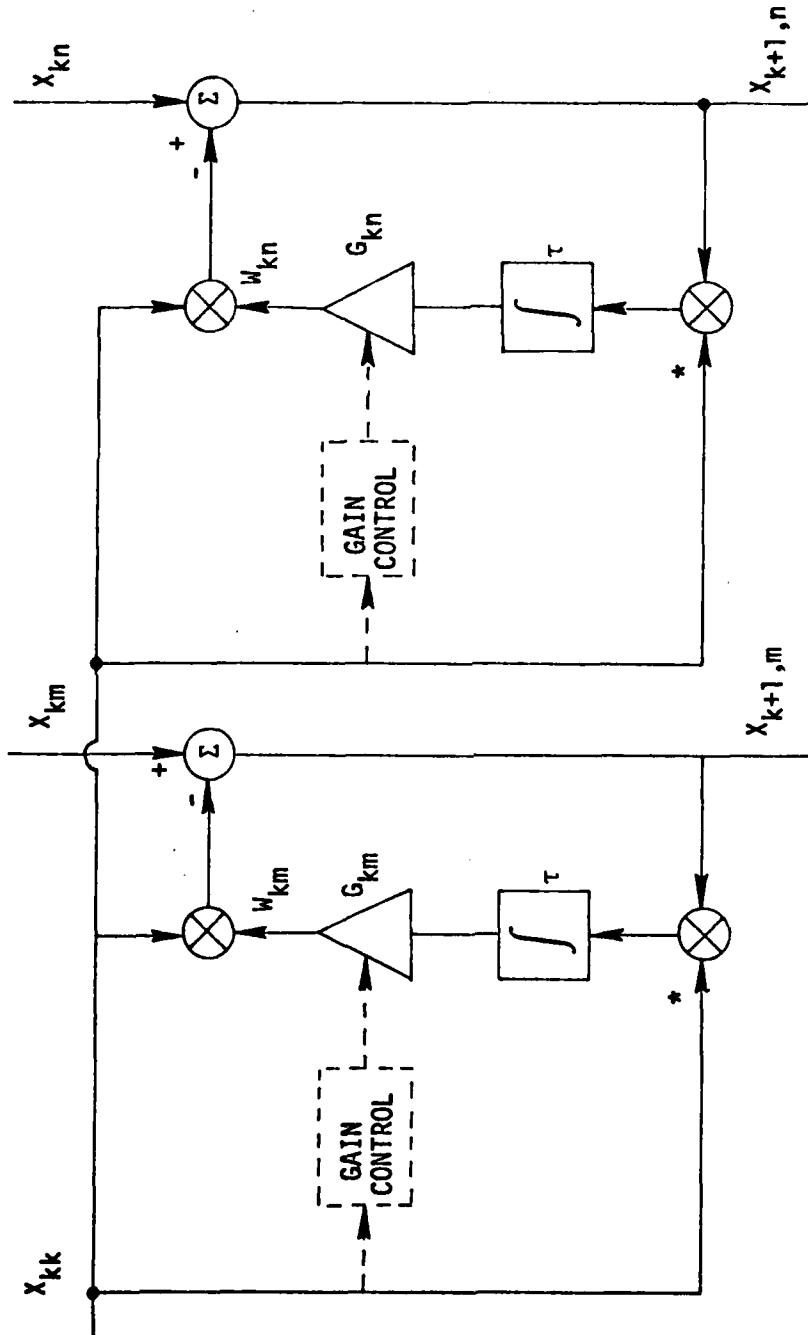

Figure 2. Analog Adaptive Control Circuits

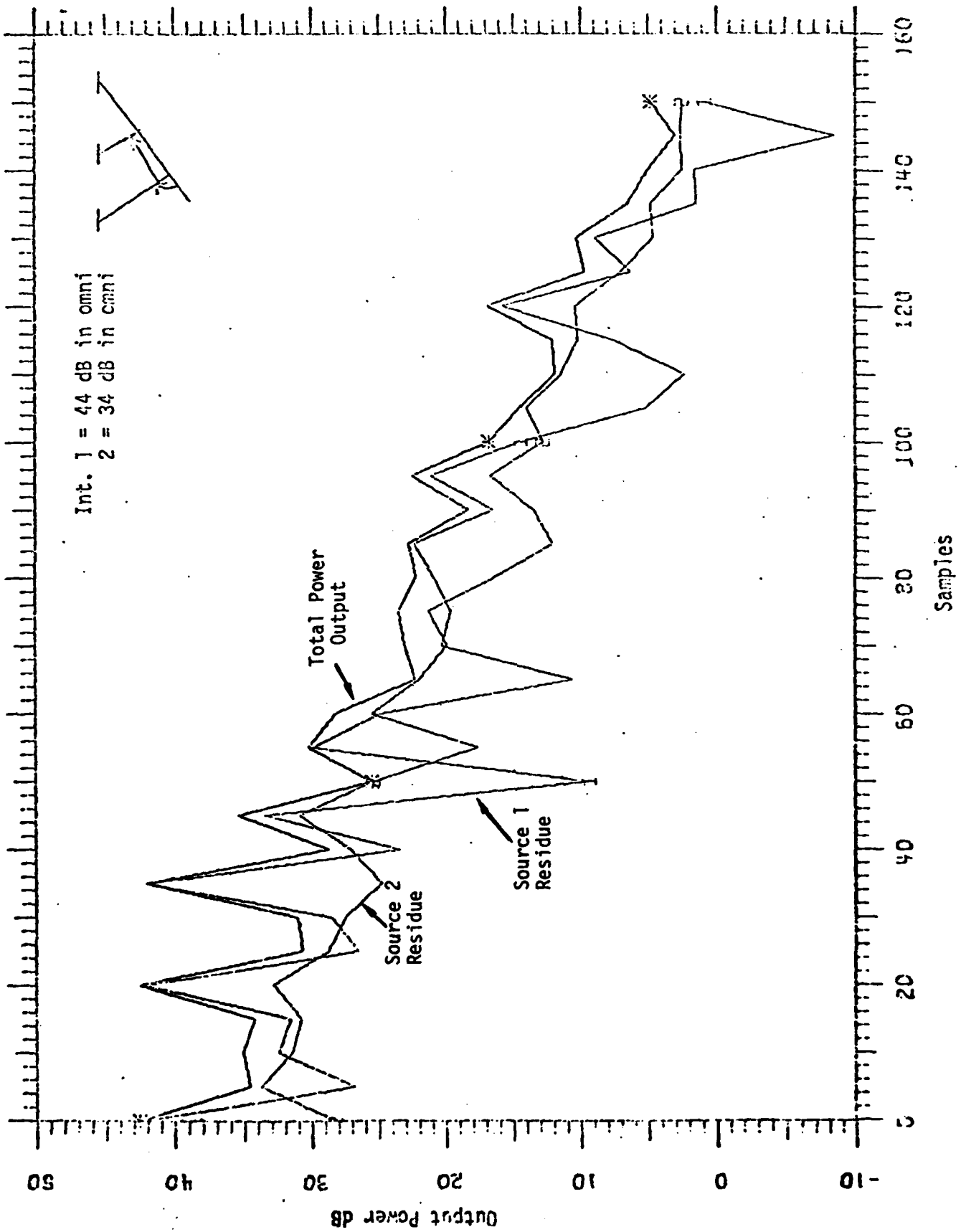

Figure 3. Simulation of Conventional 3 Element Power Equalization Array

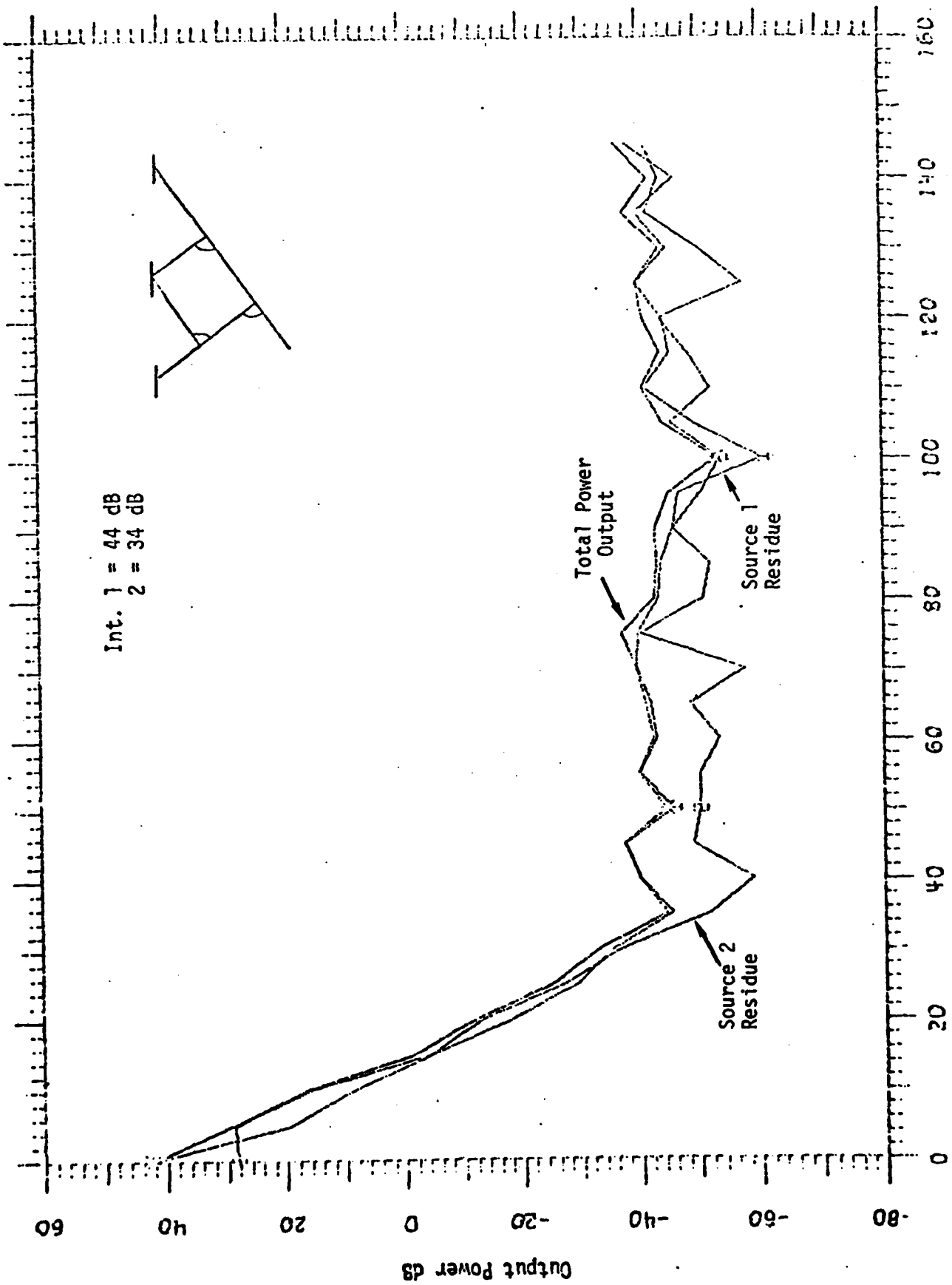

Figure 4. Simulation of 3 Element Power Equalization Array Using Gram-Schmidt Network

The next section of this report presents a simple derivation of the second moments of weight jitter in a self-orthogonalizing network. This result also provides a simple method of analyzing control loop noise in a conventional N-loop, N-element adaptive array. A general expression for control loop noise in a Gram-Schmidt network of arbitrary size is derived by induction in Section 3 below.

2.0 SECOND MOMENTS OF WEIGHT JITTER

An expression for the second moments of the weight fluctuations is required in order to compute the control loop noise component in the output of a Gram-Schmidt network. Only the second moments for weights in the same row of the network (Fig. 1) are required. Consider the network of Fig. 2, containing two weights W_{km} and W_{kn} . The weights satisfy the equation

$$\frac{\tau}{G_{kn}} \dot{W}_{kn} + X_{kk}^* X_{kk} W_{kn} = X_{kk}^* X_{kn} \quad (3)$$

If a leaky integrator is used, the $X_{kk}^* X_{kk}$ term is replaced with $(X_{kk}^* X_{kk} + \frac{1}{G_{kn}})$. To achieve near optimum weights in the steady state condition, the $1/G_{kn}$ term must be small compared to $X_{kk}^* X_{kk}$ and can be neglected.

To obtain a perturbation equation for the weight jitter, let $W_{kn} = \bar{W}_{kn} + \delta_{kn}$, where \bar{W}_{kn} is the mean value of W_{kn} . Let σ_{mn} denote $\overline{X_{km}^* X_{kn}}$. Then

$$\frac{\tau}{G_{kn}} \dot{\bar{W}}_{kn} + \sigma_{kk} \bar{W}_{kn} = \sigma_{kn} \quad (4)$$

Subtracting (4) from (3),

$$\frac{\tau}{G_{kn}} \dot{\delta}_{kn} + X_{kk}^* X_{kk} \delta_{kn} = X_{kk}^* (X_{kn} - \bar{W}_{kn} X_{kk}) + (\sigma_{kk} \bar{W}_{kn} - \sigma_{kn}) \quad (5)$$

We will consider the weight fluctuations after the mean weights have reached steady state values, i.e., $\bar{w}_{kn} = \sigma_{kn}/\sigma_{kk}$ and the last term of (5) is zero. In most cases of interest, there is sufficient smoothing in the control loop so that the weights fluctuate slowly compared to variations in the X_{kn} . The fluctuation δ_{kn} is then independent of the instantaneous X_{kk}^* X_{kk} and their product in (5) is replaced with $\sigma_{kk} \delta_n$. Then (5) reduces to

$$\frac{\tau}{G_{kn}} \dot{\delta}_{kn} + \sigma_{kk} \delta_{kn} = X_{kk}^* (X_{kn} - \bar{w}_{kn} X_{kk}) = X_{kk}^* U_n \quad (6)$$

Note that the right side of (6) is X_{kk}^* times $(X_{k+1,n} + \delta_{kn} X_{kk})$, i.e., U_n is the output $X_{k+1,n}$ less the component of $X_{k+1,n}$ due to the fluctuation in w_{kn} .

In (6), the weight fluctuation δ_{kn} is smoothed by a low pass filter with impulse response

$$h_n(t) = \frac{1}{\tau_n \sigma_{kk}} e^{-t/\tau_n} \quad (7)$$

where the effective time constant $\tau_n = \frac{\tau}{G_{kn} \sigma_{kk}}$. The output of this filter is

$$\delta_{kn}(t) = \int_{\tau=0}^{\infty} h_n(\tau) X_{kk}^*(t-\tau) U_n(t-\tau) d\tau \quad (8)$$

The second moment is

$$\overline{\delta_{km}^* \delta_{kn}} = \iint_0^{\infty} h_n(\tau) h_m(\alpha) \overline{X_{kk}^*(t-\tau) X_{kk}(t-\alpha) U_n(t-\tau) U_m^*(t-\alpha)} d\tau d\alpha \quad (9)$$

Since X_{kk} is independent of both U_n and U_m ,

$$\overline{\sigma_{km}^* \sigma_{kn}} = \int_0^{\infty} \int_0^{\infty} h_n(\tau) h_m(\alpha) R_{kk}(\tau-\alpha) R_{mn}(\alpha-\tau) d\tau d\alpha \quad (10)$$

where:

$$\begin{aligned} R_{kk}(u) &= \overline{X_{kk}^*(t) X_{kk}(t+u)} \\ R_{kk}(0) &= \sigma_{kk} \\ R_{mn}(u) &= \overline{U_m^*(t) U_n(t+u)} \end{aligned}$$

As noted earlier, we consider the usual case where the bandwidth of an adaptive loop is small compared to the bandwidth of the input X_{kk} and X_{kn} . In (6), the bandwidth of the low pass filter represented by the left side of the equation is small compared to the bandwidth of the noise driving function $X_{kk}^* U_n$ on the right side. Thus, the impulse response functions $h_n(\tau)$ are very long in duration relative to the width of the correlation functions R_{kk} and R_{mn} . The expression (10) for the second moment can be rewritten in the form

$$\begin{aligned} \overline{\delta_{km}^* \delta_{kn}} &= \int_0^{\infty} h_n(\tau) d\tau \int_{-\infty}^{\tau} h_m(\tau-u) R_{kk}(u) R_{mn}(-u) du \quad (11) \\ &= \frac{1}{\tau_m \tau_n \sigma_{kk}^2} \int_0^{\infty} e^{-\frac{(\tau_m + \tau_n)\tau}{\tau_m \tau_n}} d\tau \int_{-\tau}^{\infty} R_{kk}(-u) R_{mn}(u) e^{-z/\tau_m} dz \\ &= \left(\frac{1}{\tau_m + \tau_n} \right) \frac{R_{kk}(0) R_{mn}(0)}{\sigma_{kk}^2} \Delta \end{aligned}$$

In evaluating the integral with respect to z , the exponential term e^{-z/τ_n} is approximately unity over the z interval where the R_{kk} and R_{mn} terms are non-zero. In effect, Δ is the time interval between independent samples of the $X_{kk}^* U_n$ driving function in (6). More precisely

$$\Delta = \frac{1}{R_{kk}(0) R_{mn}(0)} \int_{-\infty}^{\infty} R_{kk}(-z) R_{mn}(z) dz \quad (12)$$

The resulting equation for the second moment of the weight fluctuations is

$$\overline{\delta_{km}^* \delta_{kn}} = \left(\frac{\Delta}{\tau_m + \tau_n} \right) \frac{R_{mn}(0)}{\sigma_{kk}} \quad (13)$$

In many applications of adaptive arrays, the input power levels can vary over a wide range. It is desirable to include some form of AGC in these cases to prevent wide variations in effective loop time constants, which result in variations in control loop noise and convergence rate. One method of achieving gain control is illustrated in Fig. 2. The G_{kn} can be decreased when the input power increases. Let

$$G_{kn} = \frac{G}{\sigma_{kk}} \quad (14)$$

Then the equation for the second moments, (13), reduces to

$$\overline{\delta_{km}^* \delta_{kn}} = \frac{G\Delta}{2\tau} \frac{R_{nm}(0)}{\sigma_{kk}} \quad (15)$$

$$= \frac{G}{2(\tau/\Delta)} \frac{U_m^* U_n}{\sigma_{kk}}$$

In effect, the integration time constant is measured in units of Δ , the correlation time of the input noise. When the loop gains are normalized as in (14), the contribution of one control loop to the weight jitter noise in its output, $\overline{|\delta_{kn}|^2} \sigma_{kk}$, is independent of σ_{kk} . Also, the transient response of the loop remains constant independent of σ_{kk} .

A second method of achieving AGC in the network is indicated in Fig. 5, where the outputs $\{Z_n\}$ are orthonormal. The gain of each box can be adjusted to keep the $\overline{|x_{kk}|^2}$ constant, say unity. In this case, the second moments of the weight fluctuations are again given by (15). With the $\overline{|x_{kk}|^2}$ normalized to unity, the effective time constant determining the transient response to each loop is τ/G . The two methods of achieving AGC, illustrated in Figs. 1 and 5 respectively, are equivalent in terms of both transient response and output noise due to weight jitter.

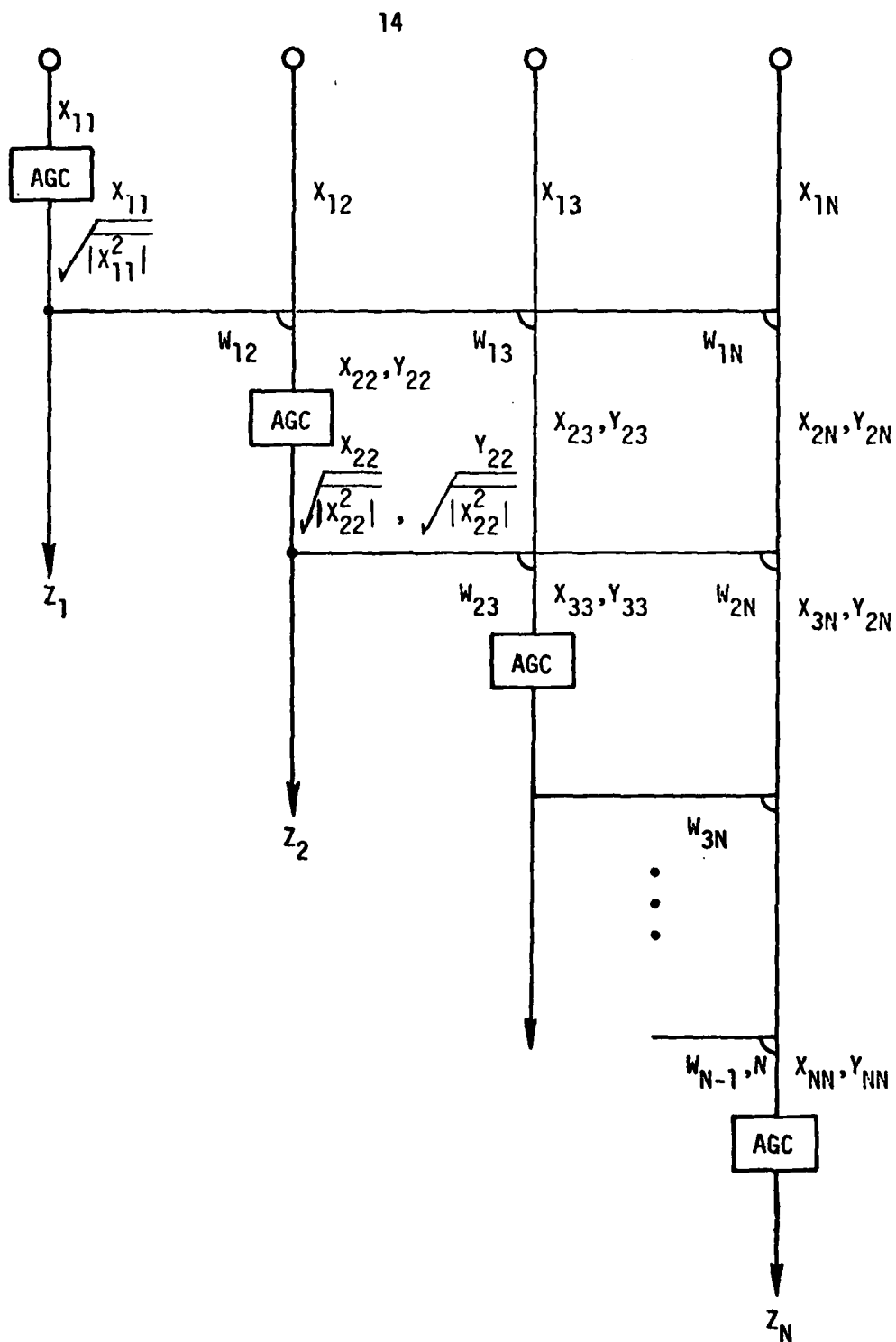

Figure 5. Self Orthogonalizing Network with AGC

3.0 EXCESS OUTPUT NOISE DUE TO WEIGHT JITTER

Consider the Gram-Schmidt network of Fig. 1. Each node in the network consists of an adaptive control loop as illustrated in Fig. 2. The variables X_{kn} in Fig. 1 denote the noise at various points in the network when all weights have their mean steady state values. The weights are again represented as the sum of mean values \bar{W}_{kn} and small fluctuating components δ_{kn} . In terms of these variables, the network is described by the following equations

$$W_{kn} = \bar{W}_{kn} + \delta_{kn} \quad (16)$$

$$\bar{W}_{kn} = \frac{\overline{X_{kk}^* X_{kn}}}{|X_{kk}|^2} \quad (17)$$

$$X_{k+1,n} = X_{kn} - \bar{W}_{kn} X_{kk} \quad (18)$$

We define a set of Y_{kn} , additive to the set of X_{kn} at the respective points in the network, as the additional noise components due to weight jitter earlier in the network (see Fig. 5). It is assumed that the Y_{kn} are small compared to the X_{kn} . The Y_{kn} satisfy the equations

$$Y_{k+1,n} = Y_{kn} - \bar{W}_{kn} Y_{kk} - \delta_{kn} X_{kk} \quad (19)$$

$$Y_{1n} = 0$$

Note that the second order term $\delta_{kn} Y_{kk}$ is assumed small relative to Y_{kn} and $\bar{w}_{kn} Y_{kk}$, and has been neglected. The theory developed here is a first order perturbation analysis, based on small δ_{kn} and Y_{kn} . The effect of weight jitter earlier in the network is neglected in computing the weight jitter at a given node.

We consider the case where the effective time constants are the same for all adaptive loops in the network. It is further assumed that the X_{kk} are all normalized to unit power as shown in Fig. 5 to achieve the AGC. Let all $G_{kn} = G$, $\overline{|X_{kk}|^2} = 1$ for all k , and $\tau_1 = \tau/\Delta$, the time constant measured in sample intervals of the input noise. From (15), the second moments of the weight fluctuations are then

$$\overline{\delta_{km}^* \delta_{km}} = \frac{G}{2\tau_1} \overline{X_{k+1,m}^* X_{k+1,n}} \quad (20)$$

since the X_{kn} as defined here are equal to the U_n of (15).

The following expression for the second moments of the Y_{kn} will be proved by induction

$$\overline{Y_{km}^* Y_{kn}} = (k-1) \frac{G}{2\tau_1} \overline{X_{km}^* X_{kn}} \quad (21)$$

Assume that (21) is true for row k of the self-orthogonalizing network.

Then for row $k+1$,

$$\overline{Y_{k+1,m}^* Y_{k+1,n}} = \overline{(Y_{km} - \bar{w}_{km} Y_{kk})^* (Y_{kn} - \bar{w}_{kn} Y_{kk})} + \overline{\delta_{km}^* \delta_{kn} |X_{kk}|^2} \quad (22)$$

This equation is obtained from (19) and the observation that the instantaneous Y_{kn} are independent of the δ_{kn} . Substituting (21) and (20) into (22) gives

$$\begin{aligned} \overline{Y_{k+1,m}^* Y_{k+1,n}} &= \frac{(k-1)G}{2\tau_1} (\overline{X_{km}^* X_{kn}} - \overline{W_{km}^* X_{kk}^* X_{kn}} - \overline{W_{kn} X_{km}^* X_{kk}} \\ &+ \overline{W_{km}^* \overline{W_{km}} |X_{kk}|^2}) + \frac{G}{2\tau_1} \overline{X_{k+1,m}^* X_{k+1,n}} \end{aligned} \quad (23)$$

Substituting (18) into (23), it reduces to

$$\overline{Y_{k+1,m}^* Y_{k+1,n}} = \frac{[(k+1)-1]G}{2\tau_1} \overline{X_{k+1,m}^* X_{k+1,n}} \quad (24)$$

This proves that if (21) is true for row k of a Gram-Schmidt network, it is also true for row $(k+1)$. Note that this equation remains valid after AGC. It remains to be shown that (21) is true for one row. It is clearly satisfied for the first row. However, the $k=1$ row is a special case, since there is no weight jitter noise on the array inputs, X_{1n} . For row 2, the weight jitter noise is due entirely to fluctuations in the W_{1n} . From (20),

$$\overline{\delta_{1m}^* \delta_{1n}} = \frac{G}{2\tau_1} \overline{X_{2m}^* X_{2n}} \quad (25)$$

and the corresponding second moments of the Y_{2n} are

$$\overline{Y_{2m}^* Y_{2n}} = |X_{11}|^2 \overline{\delta_{1m}^* \delta_{1n}} = \frac{G}{2\tau_1} \overline{X_{2m}^* X_{2n}} \quad (26)$$

since $\overline{|x_{11}|^2}$ is unity. Thus (21) is satisfied for row 2 and throughout the remainder of the network. This completes the proof of (21). The assumptions in the proof are normalization of all x_{kk} to unit power, and equality of the G and τ parameters at all nodes.

The control loop noise component at the output of the network in Fig. 1 is then

$$\overline{|y_{NN}|^2} = \frac{G(N-1)}{2\tau_1} \overline{|x_{NN}|^2} \quad (27)$$

This result applies for Gram-Schmidt networks of any size.

4.0 FULL FEEDBACK IN SELF-ORTHOGONALIZING NETWORKS

It is interesting to consider what happens in the Gram-Schmidt network of Fig. 1 when the adaptive loop at one node fails. Assume, for example, that the loop generating W_{12} in Fig. 1 fails and $W_{12} = 0$. If $\overline{x_{11}^* x_{12}} \neq 0$, this is not the correct weight. In this case, x_{11} and x_{22} are not independent, and x_{22} equals x_{12} . The network consisting of the first 3 columns, generating the output Z_3 , would not successfully null two interference sources. This can be shown as follows.

The output of the third column, Z_3 , has a mean square value of

$$\overline{|Z_3|^2} = \overline{|x_{13} - W_{13} x_{11} - W_{23} x_{22}|^2} \quad (28)$$

This output power is minimized for optimum weights W_{13} and W_{23} which satisfy the equation

$$W_{13} \overline{|x_{11}|^2} + W_{23} \overline{x_{11}^* x_{22}} = \overline{x_{11}^* x_{13}} \quad (29)$$

$$W_{13} \overline{x_{22}^* x_{11}} + W_{23} \overline{|x_{22}|^2} = \overline{x_{22}^* x_{13}}$$

The weights generated by the network of Fig. 1 are

$$W_{13} = \frac{\overline{x_{11}^* x_{13}}}{\overline{|x_{11}|^2}}$$

$$W_{23} = \frac{\overline{x_{22}^* x_{23}}}{\overline{|x_{22}|^2}} = \frac{\overline{x_{22}^* x_{13}}}{\overline{|x_{22}|^2}} - \frac{\overline{(x_{11}^* x_{13})(x_{22}^* x_{11})}}{\overline{|x_{11}|^2} \overline{|x_{22}|^2}} \quad (30)$$

These steady state weights are optimum when $\overline{X_{11}^* X_{22}} = 0$, i.e., when the correct weight is generated at the W_{12} node. Otherwise, when $\overline{X_{11}^* X_{12}} \neq 0$ the three element network does not develop an optimum steady state solution.

An alternative method of implementing a self-orthogonalizing array is illustrated in Fig. 6. The output of a column, Z_n , is fed back as one input to each node in the column. The inputs to the correlator generating the weight W_{kn} are X_{nn} and X_{kk} . By comparison with the network of Fig. 1, the $X_{k+1,n}$ input to the W_{kn} correlator is replaced with X_{nn} , the column output. This modified network will also develop a set of independent outputs Z_n . Furthermore, the use of this full feedback on the n th column of the array assures that the output Z_n is independent of all X_{kk} for $k < n$ in the steady state condition.

For example, consider the output Z_3 in Fig. 6. When a weight has reached its steady state value, the two inputs to the correlator generating that weight are uncorrelated. Thus the correct steady state value for $\overline{W_{12}}$ satisfies the equation

$$\overline{X_{11}^* X_{22}} = \overline{X_{11}^* (X_{12} - \overline{W_{12}} X_{11})} = 0 \quad (31)$$

Suppose $W_{12} = 0$, a failure at the first node. The steady state weights $\overline{W_{13}}$ and $\overline{W_{23}}$ then satisfy the equation

$$\overline{X_{11}^* (X_{13} - \overline{W_{13}} X_{11} - \overline{W_{23}} X_{12})} = 0 \quad (32)$$

$$\overline{X_{12}^* (X_{13} - \overline{W_{13}} X_{11} - \overline{W_{23}} X_{12})} = 0$$

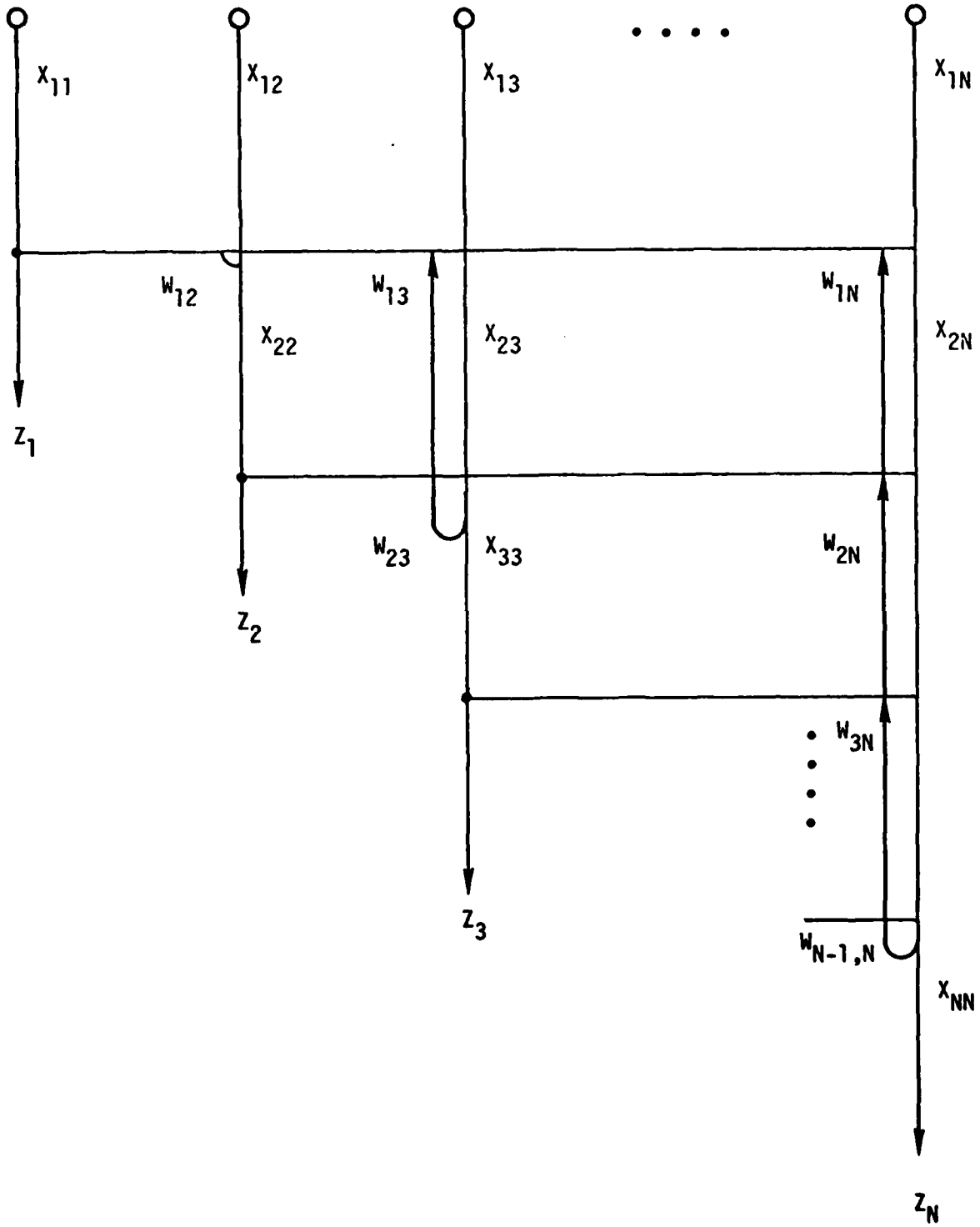

Figure 6. Self-Orthogonalizing Network with Full Feedback

These weights do satisfy (29), and thus are the optimum weights for the network when $W_{12} = 0$. The output Z_3 is the same with the network of Fig. 6, independent of W_{12} .

More generally, when the weight W_{kn} is in error due to failure at the kn node, the steady state outputs $Z_{n+1}, Z_{n+2}, \dots, Z_N$ will be correct (i.e., independent of Z_k for $k < n+1$) in the network of Fig. 6. These later outputs would be wrong due to the W_{kn} error in the network of Fig. 1.

The weight jitter is also smaller at most nodes with the full feedback network of Fig. 6. In computing the second moments of weight fluctuations with full feedback, the two inputs to a correlator generating W_{kn} are X_{kk} and Z_n . The quantity U_n in (6) is replaced with Z_n . The derivation follows closely that of Section 2.0, with a final result

$$\overline{\delta_{km}^* \delta_{kn}} = \frac{G}{2\tau_1} \frac{\overline{Z_m^* Z_n}}{\sigma_{kk}} \quad (33)$$

in place of (20). In the near steady state condition $\overline{|Z_n|^2}$ is less than $\overline{|X_{k+1,n}|^2}$ for $k+1 < n$, so the mean square weight jitter is also smaller for a given G/τ_1 ratio.

However, this does not imply that the control loop noise component is smaller in the output of a full feedback network (Fig. 6) than in the Gram-Schmidt network (Fig. 1) for a given G/τ_1 at all nodes. The cross moments of the weight fluctuations also affect this control loop noise component. With full feedback, all weight fluctuations are mutually independent (i.e., $\overline{\delta_{km}^* \delta_{ln}} = 0$ unless $k=l$ and $m=n$). For different nodes in a column, the X_{kk} are independent and $R_{kk} = 0$ in (10). For different

nodes in a row, the Z_n are independent and $R_{mn} = 0$ in (10). At least in the first order perturbation theory of control loop noise of Section 2.0, all weight fluctuations are independent.

All nodes in the network which precede a given output contribute to the control loop noise component in that output. The control loop noise in Z_n includes $(n-1)$ components due to weight jitter in the n th column, each of mean square value $G/2\tau_1$. This again assumes that the X_{kk} are normalized to unit power. These components from the n th column add up to $\frac{(n-1)G}{2\tau_1} \overline{|Z_n|^2}$. Additional noise is contributed by all nodes in the network of Fig. 6 for which $k < n$. Thus, the total control loop noise in the output Z_n exceeds the weight jitter noise for the corresponding Gram-Schmidt network (Fig. 1), which is given by (27) and equals the noise component from the n th column (Fig. 6) alone.

For example, with the full feedback network and all X_{kk} normalized to unit power, the control loop noise component in Z_3 is

$$\overline{|Y_{33}|^2} = \frac{G}{2\tau_1} (2\overline{|Z_3|^2} + \overline{|W_{23}|^2}) \quad (34)$$

The corresponding control loop noise for the Gram-Schmidt network is

$$\overline{|Y_{33}|^2} = \frac{G}{2\tau_1} 2\overline{|Z_3|^2} \quad (35)$$

and is less.

In choosing between the two alternative methods of feedback, transient response of the weights must also be considered. With full feedback, the transient response of the weights in row n depends on the covariance

matrix of the X_{kk} for $k < n$. It is well known that this conventional full feedback network provides slow convergence when the eigenvalues of this matrix are widely different in value. However, since the X_{kk} are normalized and become independent after earlier weights have converged, this covariance matrix approaches the identity matrix. This suggests that convergence should be rapid in either the Gram-Schmidt network or the full feedback network of Fig. 6.

5.0 CONCLUSIONS

A generalized expression has been derived for the weight jitter noise in the output of a Gram-Schmidt self orthogonalizing network of any dimensionality (Eq. 27). In earlier quarterly reports on this contract, it was shown that these networks transform the inputs to a set of independent variables, the networks can be utilized readily in either pilot signal or power inversion arrays for communications, and that this transformation provides fast convergence in cases of disparate eigenvalues where the more conventional circuits converge slowly.

An alternative method of implementing a self-orthogonalizing array, using full feedback along each column (Section 4 above), is more tolerant to failures at nodes in the network, but generates more weight jitter noise in the output for a given convergence rate.

REFERENCES

1. L. E. Brennan, E. L. Pugh, and I. S. Reed, "Control Loop Noise in Adaptive Array Antennas", IEEE Trans. AES, March 1971.
2. I. S. Reed, J. D. Mallett, and L. E. Brennan, "Rapid Convergence Rate in Adaptive Arrays", IEEE Trans. AES, Nov. 1974.
3. W. D. White, "Cascade Preprocessors for Adaptive Arrays", IEEE Trans. AP, Sept. 1976.
4. C. Girandau, "Optimum Antenna Processing: A Modular Approach", Part 2 of Aspects of Signal Processing, Edited by G. Tacconi, D. Reidel Publishing Co., 1977.

LMED
-8