

12
B.5

LEVEL III

AD

AD-E400 615

AD A 099 493

SPECIAL PUBLICATION ARLCD-SP-81001

MODERN METHODS OF ANALYSIS FOR CONTROL
OF CONTINUOUS NITROGUANDINE PROCESS

T. H. CHEN
W. FUN ARK
C. RIBAUDO
W. J. FISCO
F. X. MURPHY
H. KRAMER
T. C. CASTORINA

DTIC
ELECTE
JUN 1 1981
S B D

MAY 1981

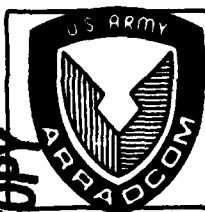

US ARMY ARMAMENT RESEARCH AND DEVELOPMENT COMMAND
LARGE CALIBER
WEAPON SYSTEMS LABORATORY
DOVER, NEW JERSEY

DTIC FILE COPY

APPROVED FOR PUBLIC RELEASE; DISTRIBUTION UNLIMITED.

81 5 21 004

The views, opinions, and/or findings contained in this report are those of the author(s) and should not be construed as an official Department of the Army position, policy or decision, unless so designated by other documentation.

Destroy this report when no longer needed. Do not return it to the originator.

The citation in this report of the names of commercial firms or commercially available products or services does not constitute official endorsement or approval of such commercial firms, products, or services by the United States Government.

UNCLASSIFIED

SECURITY CLASSIFICATION OF THIS PAGE (When Data Entered)

REPORT DOCUMENTATION PAGE		READ INSTRUCTIONS BEFORE COMPLETING FORM
1. REPORT NUMBER SPECIAL PUBLICATION ARLCD-SP-81001	2. GOVT ACCESSION NO. AD-A099	3. RECIPIENT'S CATALOG NUMBER 493
4. TITLE (and Subtitle) MODERN METHODS OF ANALYSIS FOR CONTROL OF CONTINUOUS NITROGUANIDINE PROCESS	5. TYPE OF REPORT & PERIOD COVERED	
	6. PERFORMING ORG. REPORT NUMBER	
7. AUTHOR(s) T.H. Chen, W.Fun Ark, C. Ribaldo, W.J. Fisco, F.X. Murphy, H. Kramer, and T.C. Castorina	8. CONTRACT OR GRANT NUMBER(s)	
9. PERFORMING ORGANIZATION NAME AND ADDRESS ARRADCOM, LCWSL Energetic Materials Div (DRDAR-LCE-C) Dover, NJ 07801	10. PROGRAM ELEMENT, PROJECT, TASK AREA & WORK UNIT NUMBERS MM&T - Project 5784447 Nitroguanidine Process Control Analytical Systems	
11. CONTROLLING OFFICE NAME AND ADDRESS ARRADCOM, TSD STINFO Div (DRDAR-TSS) Dover, NJ 07801	12. REPORT DATE MAY 1981	
	13. NUMBER OF PAGES 88	
14. MONITORING AGENCY NAME & ADDRESS (if different from Controlling Office)	15. SECURITY CLASS. (of this report) Unclassified	
	15a. DECLASSIFICATION/DOWNGRADING SCHEDULE	
16. DISTRIBUTION STATEMENT (of this Report) Approved for public release, distribution unlimited.		
17. DISTRIBUTION STATEMENT (of the abstract entered in Block 20, if different from Report)		
18. SUPPLEMENTARY NOTES This project was accomplished as part of the U.S. Army's Manufacturing Methods and Technology Program. The primary objective of this program is to develop, on a timely basis, manufacturing processes, techniques, and equipment for use in production of Army materiel.		
19. KEY WORDS (Continue on reverse side if necessary and identify by block number) MM&T-Quality & process control British aqueous fusion process Nitroguanidine (NQ) Instrumental methods Continuous NQ production Dedicated microprocessors Guanidine nitrate Polarography Ultraviolet absorption spectroscopy Ion chromatography		
20. ABSTRACT (Continue on reverse side if necessary and identify by block number) Modern instrumental methods of analyses with high potential for automated on-line adaptability have been developed for the monitoring and quality control of the British aqueous fusion continuous nitroguanidine process at the Sunflower Army Ammunition Plant (SFAAP), DeSoto, Kansas. The methods involve the utilization of polarography, ultraviolet absorption spectrophotometry, and ion chromatography interfaced with dedicated microprocessors. The procedures obviate the need for classical wet chemical analyses and the time necessary to run a complete analysis of a multi-component mixture is accomplished well		

DD FORM 1473 EDITION OF 1 NOV 65 IS OBSOLETE

UNCLASSIFIED

SECURITY CLASSIFICATION OF THIS PAGE (When Data Entered)

UNCLASSIFIED

SECURITY CLASSIFICATION OF THIS PAGE(When Data Entered)

20. ABSTRACT (cont)

within a 30-minute period, with no sacrifice in analytical accuracy and precision. Anions, cations, as well as non-ionic species, present in the various process streams as complex mixtures, are capable of being resolved into their separate constituent parts and quantified by the dedicated micro-processors. These species are: carbonate, nitrate, sulfate, fluoride, guanidinium, calcium and ammonium ions; and sulfur, cyanamide, and nitroguanidine compounds. The capability represented by these methods is in keeping with the time constraints of the modern continuous nitroguanidine production line at SFAAP.

UNCLASSIFIED

SECURITY CLASSIFICATION OF THIS PAGE(When Data Entered)

ACKNOWLEDGMENT

The authors wish to express their sincere appreciation to the Munitions Production Base Modernization Agency, Dover, NJ, for their financial and overall management interface support, particularly Messrs. T. Caggiano and G. Kazin (SARPM-PBM-EE); ARRADCOM's Energetic Systems Process Division's interface support, principally, Mr. A. Litty (DRDAR-LCM-E); and the Hercules, Inc., Sunflower Army Ammunitions staff's support of the analytical techniques application, notably Messrs. R. Frankenfield and D. Nelson; and Messrs. T. Stutz and J. Turrentine of the Commandant's Office at Sunflower (SARSU).

Accession For	
NTIS GRA&I	<input checked="" type="checkbox"/>
DTIC TAB	<input type="checkbox"/>
Unannounced	<input type="checkbox"/>
Justification	
By _____	
Distribution/	
Availability Codes	
Dist	Avail and/or Special
A	

CONTENTS

	Page
Introduction	1
Experimental	1
Polarographic Determination of Sulfur	1
Total Sulfate Determination	5
Ion Chromatographic Determinations	7
Spectrophotometric Determinations	13
Cyanamide Content in GuNO_3 in Reactor Liquors	13
Procedure	14
Calibration Curves and Detection Limit	16
Determinations	
Results and Discussion	16
Polarographic Determination of Elemental	16
Sulfur Along the Guanidine Nitrate	
Process Line	
Ion Chromatographic Determinations	19
Ultraviolet Absorption Spectrophotometric Methods	21
Conclusions	31
Recommendations	33
References	35
Distribution List	77

TABLES

	Page
1 Percent compositions containing elemental sulfur along the guanidine nitrate manufacture line	37
2 Polarographic determination of free sulfur in synthetics simulating a composition in the guanidine nitrate line	38
3 Total sulfate in the synthetic sample at the low stage acid concentration mixture	38
4 Total sulfate in a synthetic sample simulating the middle stage concentration	39
5 Determination of total sulfate in a synthetic sample simulating the high stage concentration mixture	39
6 Determination of errors - $H_2SO_4 + NH_4SO_4$	40
7 Determination of errors $H_2SO_4 + (NH_4)_2SO_4 +$ nitroguanidine	40
8 Determination of errors	41
9 Accuracy and precision data of ions analyzed by IC	42
10 Data for the determination of sulfate in nitroguanidine	43
11 Compositions of the guanidine nitrate liquor discharged from the first reactor (no. 4 line in the Hercules flow chart) and the synthetic mixture	43
12 Analysis of cyanamide in the synthetic mixture	44

FIGURES

	Page
1 Ion-exchange apparatus for sulfate determination	45
2 Calibration curve for nitrate ion	46
3 Carbonate ion in carbonate liquor	47
4 Ammonium and guanidinium ions in decanter wash	48
5 Total nitrate in aqua ammonia	49
6 Sulfate in mid stage concentrator	50
7 Ion chromatogram of a decanter sludge	51
8 Minimum F^- determination in presence of SO_4^{2-}	52
9 Sulfate and nitrate content	53
10 Continuous nitroguanidine process at SFAAP	54
11 Nitroguanidine process flow diagram	55
12 Reaction of H_2NCN with $Na_2[Fe(CN)_5NO]2H_2O-$ $K_3[Fe(CN)_6] - NH_3$ reagent	56
13 Reaction of H_2NCN with $Na_2[Fe(CN)_5NO]2H_2O-$ $K_3[Fe(CN)_6] - NH_3$ reagent	57
14 Effect of reagent standing time on complex formation	58
15 Effect of reagent standing time on complex formation-absorbances were obtained at 20 minutes total elapsed time	59
16 Absorption spectra of cyanamide reagent complex	60
17 Reaction of H_2NCN with $Na_2[Fe(CN)_5NO]2H_2O-$ $K_3[Fe(CN)_6] - NH_3$ reagent	61
18 Calibration curve for the determination of cyanamide absorbances were obtained at 16 min. total elapsed time from two series of experiments (● and Δ)	62

19	Effect of guanidine nitrate liquor on cyanamide-reagent complex	63
20	Effect of guanidine nitrate on cyanamide-reagent complex	64
21	Effect of guanidine nitrate on cyanamide-reagent complex	65
22	Beer's law plot for guanidine-reagent complex	66
23	Effect of ammonium nitrate on cyanamide-reagent complex	67
24	Effect of NH_4NO_3 on cyanamide-reagent complex	68
25	Effect of NH_4Cl on cyanamide-reagent complex	69
26	Effect of NH_4^+ on cyanamide-reagent complex	70
27	CDC FORTRAN computer program for solving modified simultaneous linear equations	71
28	Effect of NH_4^+ on cyanamide-reagent and guanidinium ion-reagent complexes	73
29	Effect of NH_4^+ on guanidinium ion-reagent complex	74
30	Effect of NH_4^+ on guanidinium ion-reagent complex	75
31	Effect of NH_4^+ on cyanamide-reagent and guanidinium ion-reagent complexes	76

INTRODUCTION

A multimillion dollar facility has been built at Sunflower Army Ammunition Plant (SFAAP), DeSoto, Kansas, for the continuous production of nitroguanidine (NQ). This NQ facility utilizes the British Aqueous Fusion (BAF) process and is the only one of its kind in this country. The Nitroguanidine Support Equipment (NSE) part of the facility was constructed to prove out the continuous NQ process. Analytical procedures were required to control the process and the quality of the NQ produced. Accordingly, the Analytical Section, Chemistry Branch, Energetic Materials Division, US Army Armament Research and Development Command, Dover, NJ was assigned the task of developing initially conventional chemical methods of analyses for immediate application primarily at the NSE prove-out unit.

Although the conventional methods have become available for determining the chemical species present in the process streams, in many cases they suffer from long analysis times. Since the production of NQ is by the BAF continuous process, the development of rapid and automated methods of analyses for on-line quality and process control is most imperative. Accordingly, a Manufacturing Methods & Technology (MM&T) effort was conducted for the development of more modern instrumental methods of analyses having high potential for rapid, automated on-line adaptability. This report summarizes the results of the MM&T effort involving the utilization of polarography, ultraviolet absorption spectrophotometry, and ion chromatography interfaced with dedicated microprocessors for rapid handling of analytical data.

EXPERIMENTAL

Polarographic Determination of Sulfur

Apparatus and Reagents

A Princeton Applied Research (PAR) model 374 polarographic analyzer, operated in the differential pulse mode, with the static mercury drop electrode (SMDE) accessory (PAR, model 303) and a saturated KCl/AgCl reference electrode was used for this sulfur determination. The model 374 polarograph incorporates a microprocessor based analyzer which controls automatically all aspects of the analysis including instrument set-up, chart-labeling, sample deaeration, electrode operation, data recording, and data processing (e.g., background subtraction, concentration calculation, etc). The sample solutions were deaerated in the polarograph with methanol scrubbed argon.

The electrolyte solution was prepared from reagent grade chemicals as described below. Sulfur-free isooctane was used as the extraction solvent. Powdered, monoclinic sulfur, better than 99.9% pure, was used to prepare standard solutions and synthetic samples.

Preparation of Synthetic Samples

The composition of the precipitator slurry, the most complex mixture expected in the guanidine nitrate process line, was selected as the composition of the synthetic samples used to verify the method. Five synthetic samples were prepared by accurately weighing one gram (g) mixtures of the identified solid components of the precipitator slurry as listed in table 1, minus the sulfur. One milligram (mg) of sulfur was added to each mixture by adding a 10 milliliter (mL) aliquot of a solution of 10 mg of sulfur in 100 mL of isooctane and allowing the solvent to evaporate.

Preparation of Sample Solution

Accurately weigh 1 g of the sample, transfer it to a 250 mL beaker, and add 100 mL of water. Use a sufficient quantity of 6N hydrochloric acid to dissolve any solid carbonate present in the sample and to make the solution slightly acid. Quantitatively transfer the acidified solution, with the aid of water to a 250 mL separatory funnel. Add 15 mL of isooctane to the transferred solution and extract for 2 minutes. Allow the layers to separate and then transfer the isooctane layer to a clean dry 100 mL volumetric flask. Repeat the extraction with 25 mL and 35 mL portions of isooctane. Use 15 mL of isooctane as the final extraction and wash. The combined extracts are diluted to volume with isooctane. Transfer 1.0 mL of the diluted extract to a clean dry 10 mL volumetric flask and dilute to volume with the electrolyte solution. Reserve this solution for the sample curve run.

Preparation of the Electrolyte Solution

Transfer 0.5 mL of concentrated hydrochloric acid to a 100 mL volumetric flask and add 9.5 mL pyridine to the acid. Add sufficient quantity of methanol to dilute the pyridine and pyridium hydrochloride to volume.

Pyridinium Standard solution

Accurately weigh 10 mg of sulfur and transfer it to a 100 mL volumetric flask. Add sufficient isooctane to completely dissolve the sulfur and dilute to volume with additional isooctane. Transfer 10 mL of the isooctane solution of sulfur to a dry, clean 100 mL

volumetric flask and dilute to volume with isooctane. This solution will contain 1 mg of sulfur or 1000 ppm sulfur with respect to a 1 g sample. Transfer 1.0 mL of this diluted sulfur solution to a clean, dry 10 mL volumetric flask and dilute to volume with the electrolyte solution. Reserve this solution for the standard curve run.

Preparation of the Blank Solution

Transfer 1.0 mL of isooctane to a clean, dry 10 mL volumetric flask and dilute to volume with the electrolyte solution. Reserve the solution for the blank curve run.

Polarographic Procedure

Polarographic analyzer, model 374, settings:

Basic Console:

Analytical technique: Differential pulse polarography

Initial voltage: -0.2

Final voltage: -0.48

Replications: one

Sensitivity: low

Purge: 5 minutes

SMDE

Drop mode: DME

Drop size: M

Analysis

Switch on the power to the model 374 and allow the instrument to warm up. Pour a portion of the blank solution into a clean, dry polarographic cell and clamp the cell to the SMDE with the appropriate clamp. Check the flow of mercury drops by pressing the DISPENSE button on the SMDE. Steady flow is indicated if drops are formed and reformed as each drop is dislodged. Check the flow of purge gas by switching the PURGE button to On. Adjust gas flow to proper rate of bubble formation. Switch PURGE button to Off. Enter the purge time setting in the basic console.

After entering the settings listed above, the console display board will indicate the console is in the BLANK CURVE mode and on the STANDBY basis. Press the RUN key for start of polarographic run. On completion of run press PLAYBACK and CALCULATE keys when indicated by the display board. This will cause the recorder pen to print-out the appropriate data, e.g., initial and final voltage, peak voltage, and derivative curve traces. At the end of the print-out, the display

board will indicate the console is in the STANDARD CURVE mode and STANDBY BASIS, ready to analyze the standard solution.

Pour a portion of the standard solution into a clean, dry polarographic cell and clamp the cell to the SMDE. Press RUN key for the polarographic run. On completion press the PLAYBACK and CALCULATE keys. The print-out on the chart paper will have a tracing of the derivative curve for sulfur, its peak potential, and its peak current value in nanoamperes. While the console is on the STANDBY BASIS, enter the peak potential in channel 1 and the sulfur concentration based on a 1 g sample. For 1 mg sulfur, as in the standard solution as prepared above, enter 100 (ignore the ppb on the display board). When these specific data have been entered, the display board will indicate the console is in the SAMPLE CURVE mode and STANDBY BASIS.

To check the concentration entry, set the purge setting on the console to 0.5 seconds and press the RUN button. After PLAYBACK and CALCULATE, the chart print-out will show the concentration of the standard solution in ppm. Reset the purge setting to 5 minutes and the console will be ready for the sample run on the STANDBY basis.

Pour a portion of the sample solution into a clean, dry polarographic cell and clamp the cell to the SMDE. Make sure the display board indicates the console is in the SAMPLE CURVE mode. Press RUN button. At the completion of the polarographic run, the print-out on the chart will show the concentration of the sample in ppm.

Calculation

Calculate the percentage sulfur in sample as follows:

$$\% \text{ Sulfur} = \frac{Ax10^{-4}}{W}$$

where

A = print-out on chart, ppm

W = weight of sample

Total Sulfate Determination

Apparatus and Reagents

A spectrophotometer capable of measuring absorbance at 203 nm and 265 nm either manually or automatically operated using a single 1 cm quartz cuvette.

An ion exchange column, 1 in. x 12 in. with a coarse sintered glass filter disc to hold the exchanger, a 100 mL reservoir and a 4 mm outlet tube extending about 2 inches beyond the fritted disc, then extending back up to the reservoir and terminating in a 2 mm stopcock to control liquid flow. This design prevents the resin from running dry and facilitates regeneration. Many alternate designs are available and most are easily adaptable for this work. In figure 1, a sketch of the apparatus is given.

Dowex, 50x8, 50 to 100 mesh - A strongly acidic ion exchange resin with a capacity of 1.9 meq/g of wet resin. Prepare the column for use by washing 60 g of resin with distilled water, decanting the fines that do not settle within 30 seconds after stirring. Repeat at least four times and finally transfer the resin to the column with distilled water avoiding voids or air bubbles. Generate the column by passing 300 mL of 6N HCl through the column at a flow rate of 4-5 mL/min. After generation wash the column with distilled water until a negative test for chlorides is obtained with silver nitrate. The column is serviceable for about 30 determination, assuming 5 meq of acid/sample and 80% loading before breakthrough. Smaller columns may be used but regeneration must be done more frequently.

Sodium hydroxide, 33%; dissolve 50 g of CP sodium hydroxide in 100 mL of water, store in a plastic bottle with a screw cap avoiding exposure to carbon dioxide.

Sodium hydroxide 0.1N - pipette 8 mL of the 33% sodium hydroxide into 1 L of freshly boiled, cooled, distilled water. Standardize as follows: accurately weigh 0.5 g to 0.6 g of potassium acid phthalate to the nearest milligram and transfer to a 250 mL Erlenmeyer flask with distilled water. Add 100 mL of distilled water and 3 drops of bromthymol blue. Titrate with alkali until the color changes from yellow to blue. Calculate the normality as follows:

$$N = \frac{W/M}{V}$$

where

W = weight of potassium acid phthalate

M = M.W. of potassium acid phthalate

V = volume of sodium hydroxide

Bromthymol blue indicator solution - Dissolve 0.1 g of indicator in 8 mL of 0.2N NaOH and dissolve in 100 mL of 20% alcohol.

Synthetic solutions simulating plant operations were prepared for analysis by the proposed method. The low stage acid fraction concentration consists of sulfuric acid, 50.5%; ammonium sulfate, 12.50%; nitroguanidine, 1.60%; guanidine nitrate, 1.50%; and water, 33.90%. The middle stage acid fraction consists of sulfuric acid, 59.20%; ammonium sulfate, 15.70%; guanidine sulfate, 5.40%; water, 19.70%. The high stage composition consists of sulfuric acid, 69.70%; ammonium sulfate, 19.1%; guanidine sulfate, 6.40%; and water, 5.20%.

Preparation of standard nitrate curve - Dissolve 207.8 mg of guanidine nitrate in 800 mL of 0.1 (NH₄)₂SO₄, and make to volume in one liter flask. (1 mL = 0.1 mg nitrate). Prepare 4 reference solutions, a blank, 0.1 (NH₄)₂SO₄; 0.1 mg NO₃⁻ and 0.4 mg NO₃⁻ in 100 mL volumetric flasks with 0.1N sulfuric acid. Measure absorbance of solution at 203 nm and 265 nm as follows:

Nitrate absorbance at 203 nm = Absorbance at 203 nm -

$$\left(\frac{\text{Absorbance at 265 nm}}{3.49} \right)$$

Plot corrected absorbance versus nitrate concentration, as shown in figure 2.

Analysis of solution for sulfate: Transfer 400 to 500 mg of the spent acid either by Lunge pipette or transfer pipette to a tared weighing bottle. Weigh the bottle, or the Lunge pipette to obtain the sample weight. Transfer the same to a 100 mL beaker with 40 to 50 mL distilled water. Transfer the solution to the ion exchange column and allow the solution to percolate through at a rate of 3 to 4 mL/minute. When the meniscus near the top of the resin bed, add 20 mL of distilled water repeating the operation four additional times. Titrate with standard 0.1N base using bromothymol blue indicator solution. The endpoint is a vivid yellow to blue.

Analysis of solution for nitrate: Transfer a 20 to 30 mg sample to a 100 mL volumetric flask and make to volume with 0.1 (NH₄)₂SO₄. Measure the absorbance as described in preparation of standard curve. One milliliter 0.1N NaOH = 6.3 mg HNO₃ = mg H₂SO₄.

This correction is made because nitric acid also runs through the column and gives a slightly high result.

Calculations

$$\text{Percent H}_2\text{SO}_4 = \frac{(\text{Titer} - \text{Blank} - \text{Titer of NO}_3 \text{ equiv}) \times 4.904 \times 100}{\text{Wt. sample in milligrams}}$$

Those samples not containing nitrate:

$$\text{Percent H}_2\text{SO}_4 = \frac{(\text{Titer} - \text{Blank}) \times 4.904 \times 100}{\text{Wt. of sample in milligrams}}$$

Ion Chromatographic Determinations

Apparatus

A Dionex model 14 ion chromatograph was used throughout this study. A Honeywell Dual Channel Recorder was used to record the eluted ions.

Sampling Point Compositions

Synthetic solutions were made to approximate typical samples that are expected to be generated at the various sampling points listed below. Solutions consisted of the soluble compounds only, since with actual samples the insolubles would be filtered prior to IC analysis.

Guanidine Nitrate Area

Sampling point & nominal composition (percent)

Species present	AN*					
	recycle liquor	AN solution	Reactor liquor	Aqua ammonia	Precipitator slurry	Carbonate liquor
NH ₄ NO ₃	75.2	81.0	39.0	6.0	41.6	5.4
GuNO ₃	7.4		20.6	2.0	13.4	1.8
Ca(NO ₃) ₂	0.4		25.8		0.2	
CaCO ₃					9.6	
(NH ₄) ₂ CO ₃			0.8	9.8	0.5	
(NH ₄) ₂ S				0.1		0.1
S	0.1		0.1		0.1	
H ₂ O	16.9	19.0	11.4	81.0	32.8	67.6
C			1.9		1.2	
Solids			0.5		0.3	

*Ammonium nitrate (AN)

Guanidine Nitrate Area

Sampling point & nominal composition (percent)

Species present	Decanter wash	Absorber feed	Evaporated liquor	Clear liquor	Decanter sludge	Neutral liquor
NH ₄ NO ₃	4.8	7.574.9	44.3	9.8	43.8	
GuNO ₃	1.4	2.57.8	14.1	3.1	13.1	
Ca(NO ₃) ₂			0.4	0.3		0.2
CaCO ₃					37.5	
(NH ₄) ₂ CO ₃				0.3		
NH ₃ ·HOH				0.6		
(NH ₄) ₂ S						
S			0.1	0.1		0.1
H ₂ O	93.8	90.0	16.8	40.3	43.9	42.8
C					4.5	
Solids					1.2	

Nitroguanidine Nitrate Area

Species present	Waste cake	Mother liquor	Magma	Centrifuge wash	Wet crystals	Finished product
NH ₄ NO ₃	1.0	46.6	44.4	15.3	0.9	1.0
GuNO ₃	0.3	5.0	Cryst. 8.6 Dissol. 4.7	6.1	94.1	98.4
Ca(NO ₃) ₂		0.2	0.2			
CaCO ₃	51.0					
(NH ₄) ₂ CO ₃						
NH ₃ ·HOH						
(NH ₄) ₂ S						
S		0.1	0.1			
H ₂ O	40.0	48.1	42.0	78.6	5.0	0.6
C	6.1					
Solids	1.6					

Nitroguanidine Area

Species present	Nitrator syrup	Dilution slurry	Crude slurry	Crude filtrate	Crude & precipitated filter cake	Filter cake
(NH ₄) ₂ SO ₄	14.3	5.1	5.3	5.8	Some	
NQ	20.3	7.3	7.7	0.8	39.6	60.0
GuNO ₃	1.0	0.6	0.7	0.7		
H ₂ SO ₄	56.2	20.6	21.6	23.2		
HNO ₃	0.2	< 0.1	< 0.1	< 0.1		
H ₂ O	7.2	66.3	64.6	69.4	60.4	40.0

Strong Acid Concentrator Area

Species present	Stage - Concentrator			Recycle acid
	low	mid	high	
H ₂ SO ₄	50.5	59.2	69.0	69.2
H ₂ O	33.9	19.7	5.2	5.2
(NH ₄) ₂ SO ₄	12.5	15.7	19.4	19.2
GuNO ₃	1.5			
GuHSO ₄		5.4	6.4	6.4
H ₂ SO ₄				
<u>H₂SO₄ + H₂O</u>	59.8	75.0	93.0	93.0
<u>2 4 2</u>				
NQ	1.6			

Ion Chromatography Conditions for Individual Ions:

The following conditions were used and found satisfactory for the analysis of carbonate ion in carbonate liquor and aqua ammonia solutions.

Eluant - distilled water
 Flow rate - 1.53
 Column - caustic separator 6x500 mm
 Injection volume - 100 microliters (0.1 mL)
 Meter full scale setting - 10_μ MHO
 Recorder full scale - 500 mV
 External standard - sodium carbonate

Sample dilution:

Carbonate liquor; 1.00000 g/50 mL, 2 mL/50 mL
 Aqua ammonia; 1.00000 g/50 mL

For 0.5% $(\text{NH}_4)_2\text{CO}_3$, 20 mL/25 mL
1.1% $(\text{NH}_4)_2\text{CO}_3$, 10 mL/25 mL
2.0% $(\text{NH}_4)_2\text{CO}_3$, 5 mL/25 mL

A typical chromatogram is shown in figure 3.

The following conditions were used and found satisfactory for the analysis of ammonium and guanidinium ions in decanter wash and absorber feed solutions.

Eluant - 0.0075 NH_4Cl
Flow rate - 3.07 mL/min (40%)
Columns - precolumn (3x150 mm)
 separator (6x250 mm)
 suppressor (9x250 mm)
Injection volume - 100 microliters
Meter full scale setting - 30μ MHO
Recorder full scale - black pen, 500 mV (NH_4^+)
 red pen, 100 mV (GN^+)
External standard - NH_4Cl , and guanidine nitrate
Sample dilution for 1.00000 g/50 cm^3 , 2 cm^3 /25 cm^3
 (IC working solution)

Figure 4 shows a typical chromatogram of a decanter wash solution separating ammonium and guanidinium ions.

The following conditions were used and found satisfactory for the analysis of total nitrate content in carbonate liquor, aqua ammonia, and absorber feed solution.

Eluant - 0.0030 M NaHCO_3 and 0.0024 M Na_2CO_3
Flow rate - 2.02 mL/min (26%)
Columns - anion precolumn - (5x150 mm)
 anion separator - (3x500 mm)
 anion suppressor - (6x250 mm)
Injection volume - 100 microliters (0.1 mL)
Meter full scale setting - 30μ MHO
Recorder full scale - 1000 mV
External standard - sodium nitrate
Sample dilution: 1.00000 g/50 mL

Carbonate liquor: 3 mL/50 mL
Aqua ammonia and absorber feed: 2 mL/50 mL.

Figure 5 shows a typical chromatogram for the determination of nitrate ion in an aqua ammonia solution.

The following conditions were used and found satisfactory for the analysis of total sulfate and nitrate content in middle stage and low stage concentrator solutions.

Eluant - 0.0030 M NaHCO_3 and 0.0024 M Na_2CO_3
Flow rate - 2.02 mL/min (26%)
Columns - anion precolumn - (3x150 mm)
 anion separator - (3x500 mm)
 anion suppressor - (6x250 mm)
Injection volume - 100 microliters (0.1 mL)
Meter full scale setting - 30μ MHO
Recorder full scale - 1000 mV for sulfate analysis
 500 mV for nitrate analysis
External standard - Na_2SO_4
 NaNO_3
Sample dilution: 0.10000 g/50 cm^3
 for middle stage concentrator, 2 mL/100 mL
 for low stage concentrator, 4 mL/100 mL

Figure 6 shows a chromatogram for the determination of sulfate in a mid-stage concentrator solution.

The following conditions were used and found satisfactory for the analysis of ammonium, guanidinium, and calcium ions in reactor liquor and decanter sludge solutions.

Eluant - 0.0020 M meta-phenylenediamine.2HCl and
 0.0025 M HNO_3 (Ultrax grade)
Flow rate - 1.92 mL/min (25%)
Columns - cation precolumn - (3x150 mm)
 cation separator - (9x250 mm)
 cation suppressor - (9x250 mm)
Injection volume - 100 microliters (0.1 mL)
Meter full scale setting - 30μ MHO
Recorder full scale - 1000 mV for calcium ion
 500 mV for ammonium and guanidinium ions
External standard - calcium nitrate
 ammonium nitrate
 guanidine nitrate
Sample dilution: 0.10000 g/150 mL
 for syn. reactor liquor, 10 mL/100 mL
 for syn. decanter sludge, 20 mL/100 mL

NOTE: Precolumn and separator columns were washed for 5 minutes with 1N HNO_3 (Ultrax) and rinsed for 10 minutes with distilled water after daily analyses.

Figure 7 shows a chromatogram for the separation of ammonium, guanidinium, and calcium ions in a decanter sludge solution.

The following experiments were to determine the best set of chromatographic conditions to separate fluoride, chloride, and sulfate ions.

Eluant	Column length (mm)	Suppressor length (mm)
(1) 0.0015 M Na ₂ CO ₃	3x150, 3x500	6x250
(2) 0.0024 M Na ₂ CO ₃	3x150, 3x500	6x250
(3) 0.0020 M NaCO ₃ 0.0002 M NaHCO ₃	3x150, 3x500	6x250
(4) 0.0024 M Na ₂ CO ₃	3x150, 3x500	6x250
(5) 0.0024 M Na ₂ CO ₃ 0.0015 M NaHCO ₃	3x150, 3x500, 3x250	3x250
(6) 0.0024 M Na ₂ CO ₃ 0.0015 M NaHCO ₃	3x150, 3x500, 3x250 3x150, 3x500, 3x250	6x250 3x250
(7) 0.0024 M Na ₂ CO ₃ 0.0015 M NaHCO ₃	3x150, 3x500 3x150, 3x500	6x250 6x250

It was found that experiment number seven gave the best results.

The following conditions were used for the analysis of fluoride ion in the presence of chloride and sulfate ions. An analysis for fluoride was developed to determine if any fluoride ion is carried through the process from the fluorspar catalyst used in making calcium cyanamide (CA). Figure 8 shows chromatogram of fluoride in presence of sulfate.

Eluant - 0.0024 M Na₂CO₃ + 0.0015 M NaHCO₃

Flow rate - 1.53 mL/min (20%)

Columns - anion precolumn - (3x150 mm)

anion separator - (3x500 mm)

anion suppressor - (6x250 mm)

Injection volume - 100 microliters (0.1 mL)

Meter full scale setting - 1 μ MHO

Recorder full scale - 500 mV for 5 ppb F⁻

1000 mV for 100 ppb F⁻

Standards - sodium chloride, sodium fluoride, sodium sulfate

Sample dilutions - .0 mL of concentrated H₂SO₄ neutralized to a pH of 7.0 with 0.75 M Na₂CO₃ and diluted to 100 mL with eluant (0.0024 M Na₂CO₃ + 0.0015 M NaHCO₃). Dilute stock solution 5/100, 5/100 with eluant for IC working solution.

The following conditions were used and found satisfactory for the analysis of sulfate ion present in nitroguanidine.

Eluant - 0.0030 M NaHCO₃ and 0.0015 M Na₂CO₃
Flow rate - 2.02 mL/min (22%)
Columns - anion precolumn - (3x150 mm)
 anion separator - (3x250 mm)
 anion suppressor - (6x250 mm)
Injection volume - 100 microliters (0.1 mL)
Meter full scale setting - 10 μ MHO
Recorder full scale - 100 mV
External standard - Na₂SO₄, NaNO₃
Sample dilution: 0.20000 g/100 mL, 10 mL/50 mL

Figure 9 shows chromatogram for the determination of sulfate in nitroguanidine.

Spectrophotometric Determinations

Apparatus

The Perkin-Elmer model 450, Beckman model DK 2A, and in later experiments, the Cary 17D Ultraviolet/Visible/Near Infrared (UV/VIS NIR) spectrophotometers were used in the recording of all UV and VIS spectra and in all absorbance measurements. For the temperature control of the reaction mixture, a water bath capable of controlling temperature to $\pm 0.2^\circ\text{C}$ at about 50°C was used.

Reagents

Aldrich's 99+% cyanamide excluding 5% stabilizers (2% NaH₂PO₄, 2% H₃BO₃, and 1% H₂O), SKW's calcium cyanamide and other C.P. grade chemicals were used without further purification.

Cyanamide Content in GuNO₃ Reactor Liquors

This method is specifically designed to determine the cyanamide content, expressed in percent, of guanidine nitrate reactor liquors which contain large amounts of guanidine nitrate and ammonium nitrate.

Specimen

The specimen should be of such weight as to give a net absorption of about 0.5.

Apparatus and Glassware

Spectrophotometer capable of measuring absorbance at 525 nm.

Stopwatch.

Cells, spectrophotometer (cuvettes), 1.000 cm light path, with ground glass stopper.

Flasks, volumetric, 1000, 100, 50, and 10 mL.

Pipettes and/or burettes to deliver needed volumes.

Cylinder, graduate, 5 mL.

Weighing bottle, 50 mL.

Reagents

Sodium nitroprusside ($\text{Na}_2\text{Fe}(\text{CN})_5\text{NO}\cdot 2\text{H}_2\text{O}$), A.C.S. reagent grade.

Potassium ferricyanide $\text{K}_3\text{Fe}(\text{CN})_6$, A.C.S. reagent grade.

Ammonia, concentrated (28.3%), A.C.S. reagent grade.

Sulfuric acid, concentrated, A.C.S. reagent grade.

Sulfuric acid, 3.6N - dilute 10 mL concentrated (36N) sulfuric acid to 100 mL with water.

Water - distilled, deionized - to be used in making up all solutions.

Procedure

Preparation and Storage of Reagent

Weigh out 0.55 g sodium nitroprusside and 0.55 g potassium ferricyanide to the nearest mg and dissolve in about 35 mL water in a 50 mL volumetric flask. Add 2 mL concentrated ammonia (28.3%) from a 5 mL graduate cylinder and make to the mark with water. Mix and store in a cool, dark place overnight before use. Reagent stored for more than five days should not be used.

Analysis of Samples

On-site quenching of guanidine nitrate reactor liquor. Preweigh accurately a 50 mL weighing bottle containing about 30 mL water. Quickly dissolve about 2 g hot liquor just sampled from the reactor. Accurately weigh the bottle again and obtain the sample weight by difference. Transfer the solution to a 1000 mL volumetric flask. Rinse the inner wall of the beaker with about 20 mL H₂O and add the washing to the flask. Repeat this procedure four times. Make up the volume of the solution to about 900 mL with water. Adjust the pH of the solution to 4.0 by adding 3.6N sulfuric acid from a 10 mL burette using a pH 4.5 paper as the indicator. Make up to volume with water and mix thoroughly. Analyze the sample immediately.

Procedure

Pipette 1 to 3 mL aliquot of sample solution prepared in section "Analysis of Samples" to obtain a net absorbance of about 0.5 into a 10 mL volumetric flask. Add water if necessary to adjust the volume to approximately 3 mL. Add 2 mL reagent from a 5 mL graduate cylinder and immediately heat the mixture by immersing the content of the flask in a water bath regulated at 50 ± 0.2°C with constant swirling for exactly 5 minutes. Start a stopwatch when the flask is immersed to record the total elapsed time (TET). At 5 minutes TET, remove the flask from the water bath and cool the reaction mixture quickly under the running tap water for 60 seconds with constant swirling. Immerse the flask in the water equilibrated at room temperature for 60 seconds with constant swirling. Make up to volume with water and mix thoroughly. Measure the absorbance of the solution at 16 minutes TET in a 1 cm cell at 525 nm. Obtain the absorbance of the reagent blank in the same manner. Subtract absorbance of blank from total absorbance to obtain net absorbance.

Calculation

Calculate the percentage of cyanamide and calcium cyanamide from the following equations:

$$\text{Cyanamide \%} = \frac{(13.9)(A_{525})}{(V)(W)}$$

$$\text{Calcium cyanamide \%} = (1.906)(\text{cyanamide, \%})$$

where

A_{525} = Net absorbance at 525 nm

V = Aliquot volume of sample solution in mL

W = Weight of liquor sample in g

Calibration Curves and Detection Limit Determinations

The experimental procedure was as follows: (1) 0.2, 0.4, 0.6, and 0.8 mL aliquots of cyanamide stock solution containing approximately 0.1 mg cyanamide/mL were pipetted into 10 mL volumetric flasks. Care was exercised to avoid wetting of the ground glass neck section of the flask; (2) the neck section of the flask was rinsed with appropriate amount of distilled water to adjust the sample volume to 3 mL; (3) two milliliters of reagent was then added and the mixture was heated immediately with constant swirling by immersing the content of the flask in a water bath regulated at $50^{\circ} \pm 0.2^{\circ}\text{C}$ for exactly 5 minutes. A stopwatch was started at the onset of heating to record the TET; (4) at five minutes TET, the flask was removed from the water bath and cooled quickly with constant swirling under the running tap water for 60 seconds; (5) the reaction mixture was subsequently brought to room temperature by immersing the flask with constant swirling motion in the water equilibrated to room temperature; (6) the solution was diluted to the mark of the flask with water and mixed thoroughly; (7) the absorbance of the solution was measured at 16 minutes TET at 530 nm in a 1 cm silica cell; (8) the absorbance of the reagent blank was made in the same manner.

RESULTS AND DISCUSSION

Polarographic Determination of Elemental Sulfur Along the Guanidine Nitrate Process Line

To obtain an appreciation for the complexity of reaction systems and sampling points two figures are included. Figure 10 is a simplified block diagram of the continuous nitroguanidine process at SFAAP. This diagram shows the chemical reactions of key ingredients and the sources of impurities and interferences in various process streams. For the process and quality control, numerous sampling points are required to analyze various process streams. Some of these points are shown in figure 11 as an example. The analytical procedures were developed for synthetic mixtures representing the various sampling points. Any one given sample consisted of numerous species, some of which behaved as interfering chemical agents. The hampering role played by these agents is underscored in the ensuing discussion of results.

In the manufacture of guanidine nitrate from calcium cyanamide and ammonium nitrate, minor amounts of elemental sulfur are formed from sulfide impurities in the calcium cyanamide. Since impurity profiles are important factors in characterizing a process, a rapid and reliable method for the determination of elemental sulfur in the guanidine nitrate process streams was desired.

A survey of the literature revealed that elemental sulfur has been determined by a variety of techniques in a variety of sample types. The Hall technique (ref 1) which is used to determine elemental sulfur in petroleum fractions, appeared to be the most suitable method for use with samples taken from the aqueous guanidine nitrate process streams. In this method, elemental sulfur is extracted from the sample with isooctane and then determined by a polarographic procedure. This report describes the modified Hall procedure which was developed for determining the amount of elemental sulfur impurity along the guanidine nitrate process line.

Typical compositions expected to be encountered along the guanidine nitrate manufacturing line are listed in table 1. The 0.1% sulfur content shown for each composition is based on material balance calculations for the process. Since the precipitator slurry compositions contains all of the components that are likely to be encountered in the other compositions, it was considered to be representative of all compositions containing sulfur along the process line. Consequently, synthetic mixtures simulating this were selected to evaluate the polarographic procedure. This course was pursued to minimize the number of synthetic samples required for the evaluation.

The method being proposed here for the determination of elemental sulfur is essentially the Hall procedure. The novel features being the type of samples and the improved polarographic instrumentation. Table 2 lists the results obtained using the proposed method to determine elemental sulfur in samples simulating the composition of the precipitator slurry containing 0.1% elemental sulfur. The elapsed time for one determination was 30 minutes, with the extraction step being the most time-consuming. The use of the microprocessor-based polarograph made it possible to determine the extracted sulfur within 8 minutes. With a sacrifice of some time, a conventional polarograph could also be used for the determination.

Since the nitroguanidine plant is not operational at this writing, sampling procedures for the various expected compositions could not be developed. When the plant becomes operational, parameters affecting sampling can be defined and realistic procedures developed.

The Rapid Determination of Total Sulfate in Nitroguanidine Process Liquors

No satisfactory rapid method for the determination of sulfate ion capable of an accuracy of at least 1% at concentrations of 50% to 80% sulfate is available. The restriction that the method to be developed must be suitable for a production line limited consideration to a relatively few of the techniques reported in the literature.

The volumetric determination of sulfur as sulfate by titration with barium perchlorate using an internal indicator such as tetrahydroquinone (THQ) rhodizonic acid, eosin, etc. has been described by many investigators (refs 3,4,5). None were successful in developing a method in which a sharp or reproducible indicator change representative of the true endpoint of the titration may be obtained. Although these methods may be satisfactory when employed by a skilled, experienced technician, they have not been accorded general acceptance.

The determination of sulfate by a "technicon" on-line automatic colorimetric apparatus using barium chloranilate has been described (ref 6). Precision of $\pm 5\%$ at a concentration of 100 parts per million (ppm) of sulfate ion was reported. At a concentration of 2 ppm, other investigators (ref 7,8) have meticulously worked out each step and obtained a precision of $\pm 1\%$ with this procedure. Reproducible data could not be obtained in this investigation. Data was collected on four different samples. Table 3 is the low stage acid concentration mixture. Table 4 is the sulfate concentration of the middle stage concentration, and table 5 is the sulfate concentration in the high stage concentration. Although a total error of 12 parts per thousand is quite acceptable in volumetric analysis, an error analysis of each additive was made to determine if one particular ingredient was contributing to systematic errors. Thus, table 6 represents the titration of sulfuric acid and 15.2 mg of ammonium sulfate passed through the columns. The theoretical calculated titer is 31.16; the average titer is 31.18, which is better than 1 part per thousand. In table 7 the above two were added, and in addition, 40 mg of nitroguanidine. The calculated titer, assuming nitroguanidine strips no hydrogen ion from the column, is 31.16; the recovery was 31.04 mL, which is three parts per thousand, an acceptable volumetric error indicating no error was introduced from the nitroguanidine. In table 8, guanidine nitrate was added and the calculated theoretical titer was 34.40. After making the correction outlined in the paper an average recovery of 34.24 was obtained, which is an error of 5 parts per thousand, and the total error is about 9 parts per thousand, in good agreement with the other data.

The method is quite satisfactory for this system. However, the presence of other anions must be known for more universal application. An additional advantage of this procedure is the capability of titrating free sulfuric acid, and salts of sulfuric acid after elution through the column. The total time per determination was about 20 minutes, which makes the procedure ideal for on-line analysis.

Ion Chromatographic Determinations

This study has been directed primarily at analyzing samples at predetermined sampling point within three main areas of the continuous nitroguanidine facility at SAAP. The areas which have been considered are guanidine nitrate, nitroguanidine, and sulfuric acid concentrator. Additionally, a procedure has been developed to analyze the sulfate ion present in the nitroguanidine produced and a method for the determination of fluoride ion at low levels has also been developed.

The analytical technique used to analyze the various compositions is ion chromatography (IC). Although conventional ion-exchange procedures are well known and have been used throughout the years, IC was selected as the better alternative because of the following:

The proprietary columns used have better resolving power than conventional ion-exchange resins and accomplish a separation in a shorter time.

Trace analysis is highly amenable to IC, which uses a suppressor column in series with the separator column.

The ion chromatograph is available as a complete package from one supplier which has significantly speeded procurement procedures.

The ion chromatograph is easily adapted to automated data handling procedures, which lowers the total analysis time considerably.

Table 9 lists the precision and accuracy values for the synthetic solutions studied by ion chromatography. All values have been obtained as a result of six individual analyses and quantification done by measurement of peak heights. The precision values are given as two times the standard deviation, 2 sigma. Accuracy values are listed as percent recovery.

In addition to the solutions studied in table 1, a request was made to determine the minimum detectable amount of fluoride in the

presence of chloride and sulfate. The eluents listed in item 6 of the chromatographic conditions were tried and it was determined the minimum detectable amount of fluoride is approximately five parts per billion in the presence of 13 parts per billion of Cl^- and 41.5 parts per million of SO_4^{2-} using an eluent of 0.0024M Na_2CO_3 + 0.0015M NaHCO_3 .

Also a request was made by SAAP to investigate the feasibility of using an IC method to determine the amount of sulfate in nitroguanidine (batch no. 11-575). Two eluents were tried with the precision and accuracy values given in table 10.

Carbonate Analysis

The carbonate ion was successfully analyzed in the carbonate liquor and aqua ammonia solutions. The precision and accuracy appear to be within acceptable limits for quality control work. Although satisfactory results have been obtained to date with the carbonate column, no studies have been directed at the long term stability phenomena. Additionally, it should be indicated that the caustic separator column does not differentiate between the bicarbonate and carbonate ions.

Nitrate Analysis

Nitrate ion has been analyzed in the carbonate liquor, aqua ammonia, absorber feed (total), and low stage concentrator solutions. Analytical results obtained were quite satisfactory with no special problems observed.

Sulfate Analysis

Sulfate ion was analyzed in middle stage concentrator, low stage concentrator solutions, and in a commercial lot of nitroguanidine. The middle stage concentrator has a SO_4^{2-} nominal concentration of 75.5% whereas the SO_4^{2-} in nitroguanidine equals 0.2%. This is a good example of the varying amounts of material that can be analyzed with IC.

Fluoride Analysis

The minimum detectable amount of fluoride in the presence of chloride and sulfate has been determined to be approximately 5 parts per billion. The low detectability limit of the fluoride ion with IC should enable plant analyst to determine what amount of fluoride, if any, is being carried through the various process streams.

Ammonium, Calcium, and Guanidinium Ions

The precision and accuracy values for the guanidinium, calcium, and ammonium ions are acceptable in the reactor liquor and decanter sludge solutions. However, the ammonium accuracy values of 105.8 and 106.3 are greater than the accuracy values of 99.6 and 99.4 reported for the decanter wash and absorber feed solutions. The higher accuracy values observed may be due to the divalent eluent. The ammonium and guanidinium ions with retention time of 7.2 and 18.8 minutes, respectively, were well separated with strong monovalent eluent, 0.0075N HCl. This is in contrast to the separation of ammonium and guanidinium ions with retention times of 7.0 and 8.4 minutes, respectively, with the 0.002M meta-phenylenediamine · 2HCl and 0.0025M HNO₃. In addition to the different separation characteristics of the monovalent and divalent eluent, it was found that the linearity of the ammonium ion in the plots of peak height versus concentration was up to 40 ppm in the monovalent eluent, and up to 16 ppm in the divalent eluent.

At the present time, the weaker cation divalent eluent will separate the two monovalent ions (NH₄⁺ and Gu⁺) and the divalent ion (Ca⁺²) in a single analysis. If the ammonium ion accuracy warrants two different eluents, the down time for eluent switching and column equilibration must be considered.

Ultraviolet Absorption Spectrophotometric Methods

Rapid Determination of Cyanamide in the Guanidine Nitrate Reactor Liquor

In this method development, three criteria were used to guide this investigation. These were: (1) The method must be a rapid instrumental one for possible future application to on-line, real-time automated instrumental process monitoring and control; therefore, only those methods were considered which require less than 30 minutes analysis time; (2) the method must be sensitive, precise, and accurate for determining cyanamide which constitutes only 2% or less of the reactor liquor; a relative precision and error of about 2% was sought; (3) the method should be relatively simple to use by the plant personnel.

Pure cyanamide cannot be obtained from commercial sources. This is the direct consequence of the unique properties of cyanamide. The nitrile group in the cyanamide molecule (H₂NCN) is quite reactive. As a result, cyanamide undergoes dimerization, hydration, and trimerization to form dicyandiamide or cyanoguanidine, urea, and melamine, respectively. The rates and the extents of these reactions

depend on pH, temperature, and the storage period. Thus, Aldrich's 99+% cyanamide was found to contain approximately 5% dicyandiamide, as estimated spectrophotometrically from its intense absorption near 213 nm, in addition to the 5% stabilizer content. In addition, cyanamide is deliquescent. These combined properties have complicated this method development considerably, as will be discussed later. It may be noted that in the past little attention has been paid to the developments of rapid methods for analyzing cyanamide (ref 9). The classical silver cyanamide precipitation, followed by the volumetric determination of silver for indirect determination of cyanamide is macro in nature and also time-consuming. This method is, therefore, not suitable for process control applications.

Direct Method

In order to evaluate the feasibility of analyzing cyanamide directly in the guanidine nitrate reactor liquor, the ultraviolet absorption characteristics of cyanamide and dicyandiamide dissolved in $1.4 \times 10^{-3} \text{ N H}_2\text{SO}_4$ were investigated in the 188 nm to 400 nm range. Dicyandiamide was included in the study since the formation of this species is expected under the reactor conditions despite the omission of this compound from the material balance of the reactor in the flow chart of nitroguanidine plant. Cyanamide in $1.4 \times 10^{-3} \text{ N H}_2\text{SO}_4$ exhibits weak absorption in the 188 nm to 250 nm region with its maximum at about 192 nm, whereas, dicyandiamide, the dimerization product of cyanamide, shows intense absorption in the same region but with its maximum shifted to 214 nm. The molar absorptivities were found to be $(1.60 \pm 0.02) \times 10^4 \text{ M}^{-1} \text{ cm}^{-1}$ and approximately $300 \text{ M}^{-1} \text{ cm}^{-1}$ for dicyandiamide at 214 nm, and cyanamide at 192 nm, respectively. Later experiments indicated that the molar absorptivity, for dicyandiamide might be about 17% too high. The value for cyanamide was estimated from the absorption of cyanamide solution prepared from Aldrich's 99+% cyanamide after correcting for the intense absorption of about 5% dicyandiamide contamination. The concentration of cyanamide concentration was corrected for the presence of 5% stabilizers. Dicyandiamide follows Beer's law closely in the $1 \times 10^{-5} \text{ M}$ to $8.5 \times 10^{-5} \text{ M}$ range. Further, the absorbance appears to be temperature independent. Both $4 \times 10^{-4} \text{ M}$ cyanamide and $8.5 \times 10^{-5} \text{ M}$ dicyandiamide solutions in $1.4 \times 10^{-3} \text{ N H}_2\text{SO}_4$ were found to be stable for at least 24 hours and 7 days, respectively.

The above study shows that the absorption of cyanamide at 192 nm is only about 1/50 of that of dicyandiamide at 214 nm. This extremely unfavorable absorptivity ratio and the presence of large amounts of nitrate ion render the direct determination of cyanamide in the guanidine nitrate reactor liquor impossible by the conventional slow scanning spectrophotometry. The nitrate ion, derived

from guanidine nitrate, ammonium nitrate (AN), and calcium nitrate, absorbs strongly ($\epsilon \text{ NO}_3^-$, 203 nm = $(9.49 \pm 0.11) \times 10^3 \text{ M}^{-1}\text{cm}^{-1}$ (ref 10) throughout the absorption ranges of cyanamide and dicyandiamide (ref 11). It should be noted that with the advent of recently developed microcomputer controlled rapid scan (full spectrum in one second) ultraviolet/visible spectrophotometer, this approach becomes feasible (ref 12,13).

Conversion of Cyanamide to Dicyandiamide

The conversion of cyanamide to dicyandiamide to gain a 50-fold sensitivity for cyanamide determination and the subsequent analysis of dicyandiamide by the conventional slow scanning spectrophotometry was also determined to be impossible, owing to the exceedingly low concentration ratio of dicyandiamide to nitrate ion. This ratio is computed to be 1.4/94 from the flow chart of nitroguanidine plant. The examination of the absorption characteristics of synthetic mixtures confirmed this conclusion.

Indirect Method

Relatively few methods are available in the literature which could be applied to the rapid determination of cyanamide in the guanidine nitrate reactor liquor (ref 9,14,15,16,17,18). The sodium nitroprusside-potassium ferricyanide-ammonia (SNP-PFC-A) reagent was chosen for this investigation primarily because of the reported improved selectivity of this reagent for determining cyanamide in the presence of dicyandiamide (ref 18) over the sodium nitroprusside-potassium ferricyanide-sodium hydroxide reagent (ref 15,16), and the absence of interference by ten-fold quantity of guanidine.

Optimum Reaction Parameters

Mushkin (ref 18) used the following conditions for the formation of cyanamide-reagent complex: 5 minutes reaction time at 50°C and 10 to 15 minutes cooling to 20°C prior to absorbance measurement at 525 nm. In an attempt to reduce the analysis time and simplify the procedure, two series of experiments were carried out in which the reaction temperature was raised to 100°C to shorten the reaction time and to eliminate the temperature control. Furthermore, the cooling time to room temperature was reduced from 10 to 15 minutes, to 4 and 2 minutes in the first and second series of experiments, respectively. In the first series of experiments, the reaction volume was made up to the mark of a 10 mL volumetric flask. It was observed that this prevented effective solution mixing. Therefore, in the second series of experiments, the reaction volume was adjusted to 6 mL in a 10 mL volumetric flask. This enabled efficient mixing to achieve uniform heating of the reaction mixture.

The reaction was followed by measuring the absorbance at 530 nm as a function of reaction time at 100°C. About 0.4 mg cyanamide was employed in all experiments. The absorbance increased sharply with reaction time, reaching a maximum at about 50 seconds, and decreased at longer periods. In addition, the absorbances were found to increase significantly with standing time indicating that the reaction was incomplete. An experiment was then conducted employing the 5 minutes reaction period at 50°C. Again, the absorbance was found to increase with standing time. The initial absorbance obtained under this condition was about 50% higher than the maximum observed in the previous experiments.

The results obtained suggest that the intensely colored (purple) reaction product partially decomposed at 100°C, and the reaction did not proceed to completion under the experimental conditions. The latter may arise from excessive amounts of cyanamide (0.4 mg) used in the experiments. Thus, the two samples heated at 100°C for 50 seconds, and at 50°C for 5 minutes, respectively, required dilution by a factor of 2, prior to absorbance measurements at 530 nm. However, as can be seen from figure 12, even reducing the sample size by a factor of 4 by using 0.1 mg samples, the absorbance was still found to increase with total elapsed time (TET) up to about 40 minutes. The TET, which represents the time interval between the onset of reaction mixture heating and the absorbance measurement at 530 nm, was used to accurately follow the absorbance change with time in this and later experiments.

An attempt was then made to complete the reaction by increasing the reaction mixture heating time from 5 minutes to 10 minutes. Surprisingly, this did not improve the results (see figure 13). From these results, the following were determined to be the optimum reaction parameters for rapid analysis of cyanamide. Sample size, up to about 3 mL containing about 0.1 mg cyanamide; reagent, 2 mL, reaction condition, 5 minutes at 50°C; cooling, 60 seconds rapid cooling under running tap water followed by 60 seconds immersion in the room temperature equilibrated water; reaction vessel, 10 mL volumetric flask; absorbance measurement, 530 nm at 16 minutes TET using a 1 cm silica cell. It may be noted that at 16 minutes TET, the absorbance has already increased to 93% of the maximum, which required about 40 minutes TET. These optimum parameters were incorporated into the analytical procedures (see Experimental).

The Nature of Reacting Species

During the course of determining the optimum reaction parameters, it was found that the complex formation of cyanamide with freshly prepared reagent was strongly dependent on the standing time

of reagent. This effect is shown in figures 14 and 15. These results indicate that the colored complex resulted from the reaction of cyanamide with a new chemical species formed from the reagent. Further, the concentration of this species, possibly a pentacyanoammine or pentacyanoaquo complex, increases slowly and reaches a maximum value after approximately 10 hours standing time. The unique nature of this reagent required aging of at least 10 hours before use (see Experimental).

In order to examine the nature of the actual reactive species in the SNP-PFC-A method, comparative studies on the reactions of cyanamide with various combinations of the reactants in the reagent system, namely, SNP, PFC, SNP-A, and PFC-A, SNP-PFC, and SNP-PFC-A were conducted. The results revealed that neither SNP nor PFC alone reacted with cyanamide. Furthermore, SNP-PFC, SNP-A, and PFC-A reacted with cyanamide only to 4.4, 5.9, and 8.4%, respectively, of the reaction observed in the SNP-PFC-A reagent system. Therefore, the formation of the active species in the SNP-PFC-A method requires the presence of all three reagent components.

Absorption Characteristics

The absorption characteristics of cyanamide-reagent complex in the 460 to 600 nm range is shown in figure 16. The wavelength of maximum absorption is located at about 530 nm. The small segments of absorption curves were obtained at shorter TET's. This complex was found to be quite stable. Thus, its absorption at 530 nm reached a maximum value after 2 hours and decreased only by 7% after a 26 hour standing period.

Calibration Curves and Detection Limit for Cyanamide Determination

Two series of experiments were conducted to check the reproducibility of the calibration curve for cyanamide determination. Figure 17 shows the absorption data from which a set of data (triangles) were obtained at 16 minutes TET for the construction of figure 18. The results, obtained 3 days apart using 4 (triangles) and 6 (circles) day-old reagents, respectively, were in excellent agreement, the maximum difference from the average values being $\pm 0.7\%$ or less. Further, the data resulted in a straight line passing through the origin. From this, the sensitivity was estimated to be about 0.2 ppm taking 0.015 absorbance unit as the detection limit using a 1 cm cell.

Effects of Guanidine Nitrate Reactor Liquor on Cyanamide-Reagent Complex

A synthetic mixture of a guanidine nitrate reactor liquor was prepared to study the combined effects of ammonium nitrate, calcium nitrate, guanidine nitrate, carbon, and sulfur in the formation of the cyanamide-reagent complex. Except for the water content, the composition of the synthetic mixture was similar to that of the guanidine nitrate liquor discharged from the first reactor (see table 11). It should be noted that some CaNCN may remain in the residues of the reactor liquors. Furthermore, the formation of dicyandiamide is also expected since cyanamide dimerizes readily in alkaline solution as pointed out earlier (ref 19). As indicated in table 11, the cyanamide in the synthetic mixture was contaminated with about 50% dicyandiamide.

A comparison of the absorption spectra of synthetic and control solutions (see figure 19) shows that the presence of large quantities of various species in the synthetic mixture interfered with the cyanamide-reagent complex formation. These species altered the absorption spectrum and lowered the net absorbance at 530 nm by about 10%. The changes in the absorption characteristics over the range of 450 to 600 nm consists of reducing the absorption in the longer wavelength region while increasing the absorbance in the shorter wavelength region, the crossover point being at about 525 nm. Furthermore, the crossover of the curves could not be attributed to the increased absorption of the synthetic mixture without cyanamide (lower broken curve in figure 19), since the absorption increased throughout the whole wavelength region. In order to elucidate the observed combined effects of various species, the interference of each component species was systematically investigated.

Effect of Guanidine Nitrate on the formation of Cyanamide-Reagent Complex

Figure 20 shows the effect of guanidine nitrate (GN) on the formation of cyanamide-reagent complex. There are three important features: (1) the increased absorbances can be quantitatively accounted for by the additional absorptions of a guanidine-reagent complex whose absorption overlaps with that of cyanamide-reagent complex (see the dotted line); (2) the guanidine-reagent complex exhibits a maximum absorption at about 475 nm (see the dotted line); (3) the additive nature of the absorptions of the cyanamide-reagent and the guanidine-reagent complexes at 475 nm and 530 nm. This is shown in figure 21 constructed from figure 20. This, together with the fact that both complexes follow Beer's law closely (see figures 18 and 22), form the basis for the simultaneous determination of

cyanamide and guanidine nitrate. It is to be noted that figure 22 shows excellent linear relationships between the guanidine nitrate concentration and the absorbances of the guanidine-reagent complex at 475, 500, 515, and 530 nm, despite very low absorbance values. Thus, this study established the feasibility of simultaneously determining the two most important constituents in the guanidine nitrate reactor liquor.

Effect of Ammonium Nitrate on the Formation of Cyanamide-Reagent Complex

Figure 23 shows the effect of ammonium nitrate on the absorption characteristics of the cyanamide-reagent complex. The essential features of this effect are: (1) the lowering of the absorbance without causing changes in the relative absorbances in the entire absorption region; (2) the absorption change is directly proportional to the cyanamide concentration; (3) the presence of large amounts of ammonium nitrate has essentially no observable influence on the absorption of the reagent blank (<0.010 absorbance unit).

From these observations and the additive effect of guanidine nitrate already described, it is concluded that nitrate ion does not interfere with the cyanamide-reagent complex formation and that the ammonium ion causes partial dissociation of cyanamide-reagent complex. The proof for the absence of nitrate ion interference was obtained in the experiments where ammonium chloride was substituted for ammonium nitrate. Thus, the results in figures 24 and 25 demonstrate that for equimolar ammonium ion concentration, the effects of both ammonium nitrate and ammonium chloride are identical. The figures also show that the presence of ammonium ion reduced the absorbances of the cyanamide-reagent complex by a constant factor of 1.22 throughout the entire absorption range, i.e., NH_4^+ causes 22% dissociation of the complex. Moreover, evidently, chloride ion does not interfere with the cyanamide-reagent complex formation. The effect of NH_4^+ was found to be directly proportional to both cyanamide and NH_4^+ concentrations as can be seen in figure 26. This relationship can be quantitatively expressed by equation 1 below:

$$\Delta A = k (\text{H}_2\text{NCN}) (\text{NH}_4^+) \quad (1)$$

Where:

ΔA = absorbance difference of cyanamide and mixture

(H_2NCN) = concentration of cyanamide

(NH_4^+) = concentraton of ammonium ion

$$k = - (3.4 \pm 0.2) \times 10^4 \text{ M}^{-2} \text{ at } 530 \text{ nm}$$

The above results indicate the possibility of simultaneously determining cyanamide, guanidine and ammonium ion which represent all three important constituents in the reactor liquor. This will require the solution of the modified linear simultaneous equations shown below:

$$A(1) = B(1) X + C(1) XY + D(1)Z \quad (2)$$

$$A(2) = B(2) X + C(2) XY + D(2)Z \quad (3)$$

$$A(3) = B(3) X + C(3) XY + D(3)Z \quad (4)$$

Where:

A(1), A(2), A(3) = absorbances at three different wavelengths.

B(1), B(2), B(3) = molar absorptivities of cyanamide-reagent complex at three different wavelengths.

C(1), C(2), C(3) = k values in equation 1 at three different wavelengths.

D(1), D(2), D(3) = molar absorptivities of guanidine-reagent complex at three different wavelengths.

X = cyanamide concentration.

Y = ammonium ion concentration.

Z = guanidine nitrate concentration.

The solutions of these equations can readily be obtained in real time with a dedicated data system such as a microprocessor controlled spectrophotometer. Figure 27 shows a CDC Fortran computer program for solving equations 2 to 4. This program was applied to the initial multi-component analysis of a mixture containing 1.47×10^{-4} M cyanamide, 5.77×10^{-3} M NH_4NO_3 , and 1.44×10^{-3} M guanidine nitrate. The computed results were (see the end of program in figure 25) 1.879×10^{-4} M cyanamide, 2.25×10^{-2} NH_4^+ , and 0.843×10^{-3} M guanidine nitrate. The discrepancies observed were attributed to the interference of NH_4^+ in the guanidine-reagent complex formation.

Effect of Ammonium Ion on the Formation of Guanidine-Reagent Complex

The effect of NH_4^+ on the absorption characteristics of guanidinium ion-reagent complex is shown in figure 28. In one series of experiments (curves a-d), the concentration of guanidinium ion was kept constant while in the other (curves d-f), the concentration of ammonium ion was maintained at a fixed value. Curves g, h, and i represent, respectively, cyanamide, the mixture of cyanamide, guanidinium ion, and ammonium ion, and the mixture of cyanamide and ammonium ion. As in the case of cyanamide, NH_4^+ reduces the absorption of guanidinium ion-reagent complex by the same ratio at all wavelengths. Thus, curves d and i coincide with a/2.2 and g/1.29, respectively, within experimental error.

Figure 29 shows the relation between the absorbance difference of guanidinium ion-reagent complex as a function of ammonium ion concentration. Although somewhat lower, the results essentially agree with the linear relationship represented by the broken line.

Figure 30 shows an excellent linear relationship between absorbance difference and guanidinium ion concentration. The results in figures 29 and 30 indicate that the effect of NH_4^+ is directly proportional to both guanidinium ion and NH_4^+ concentrations. This relationship can be quantitatively expressed by the following equation:

$$\Delta A = K (\text{GH}^+) (\text{NH}_4^+) \quad (5)$$

Where:

ΔA = absorbance difference of guanidinium ion and mixture

(GH^+) = concentration of guanidinium ion

(NH_4^+) = concentration of ammonium ion

$K = -(2.3 \pm 0.2) \times 10^3 \text{ M}^{-2}$ at 475 nm

In figure 31, the absorbance of a mixture containing cyanamide, guanidinium ion, and ammonium ion is compared to that computed, assuming the effects of ammonium ion on guanidinium ion-reagent and cyanamide-reagent complexes are additive. The solid line is the curve h in figure 28 and the broken line is obtained from the sum of curves d and i. Although somewhat lower, the calculated values agree with the observed within the experimental error. Thus,

these studies established the feasibility of simultaneously determining cyanamide, guanidine nitrate, and ammonium nitrate in the reactor liquor. The application of this method will require solving of the following simultaneous equations which can readily be accomplished with a microprocessor controlled spectrophotometer.

$$A(1) = B(1) X + C(1) XY + D(1) Z + E(1) YZ \quad (6)$$

$$A(2) = B(2) X + C(2) XY + D(2) Z + E(2) YZ \quad (7)$$

$$A(3) = B(3) X + C(3) XY + D(3) Z + E(3) YZ \quad (8)$$

$$A(4) = B(4) X + C(4) XY + D(4) Z + E(4) YZ \quad (9)$$

Where:

E(1), E(2), E(3), E(4) = k values in equation 5 at four different wavelengths.

A(4) = absorbance at the fourth wavelength.

B(4) = molar absorptivity of cyanamide-reagent complex at the fourth wavelength.

C(4) = k value in equation 1 at the fourth wavelength.

D(4) = molar absorptivity of guanidine-reagent complex at the fourth wavelength.

Other symbols = as defined in equations 2 to 4.

This method will be evaluated for application to rapid simultaneous analyses of cyanamide, ammonium ion, and guanidinium ion employing a microprocessor-controlled rapid scan ultraviolet/visible spectrophotometer.

Effect of Dicyandiamide, Sulfur, and Carbon on the Formation of Cyanamide-Reagent Complex

The addition of dicyandiamide in the amount approximately equal to cyanamide content was found to have negligible effect on the absorptions of cyanamide-reagent complex and the reagent blank.

Since sulfur and carbon are insoluble in aqueous solutions, interactions with cyanamide-reagent complex are not expected. However, the presence of these species as suspensions will cause errors in the absorbance measurements. This problem, which can readily be overcome by sample solution centrifugation, was not encountered in the synthetic mixture analysis.

Rapid Method for Determining Cyanamide in the Guanidine Nitrate Reactor Liquid

Procedure

As a result of the systematic investigation of interferences, the observed combined effects of component species (figure 19) can be accounted for quantitatively in terms of the formation of guanidine-reagent complex in addition to the cyanamide-reagent complex and the partial dissociation of these complexes by NH_4^+ .

Cyanamide Standard

A simple, rapid method of preparing cyanamide standard solution for use by the plant personnel is being developed. Three alternative sources for cyanamide are being evaluated. These include the cyanamide prepared from thiourea and mercuric oxide, cyanamide solution prepared from silver cyanamide, and cyanamide solution extracted at pH 4 from SKW CaNCN.

Precision and Accuracy

During the course of this study, it was found that the age of reagent affects the cyanamide-reagent complex formation to some extent (approximately 16%). Furthermore, the standard solution prepared from silver cyanamide was not standardized. For these reasons, the standards and the synthetic mixtures were analyzed on the same day using the same reagent and the accuracy computations were based on the ratio of the absorbance of the external cyanamide standard measured at 528 nm to that of the synthetic mixture obtained at 522 nm, and the nominal concentration of the standard. The composition of the synthetic mixture was essentially identical to that shown in table 11.

The results obtained are summarized in table 12. Although the data are limited to one synthetic composition, the relative precision and the relative error were found to be about 1% and 2%, respectively.

CONCLUSIONS

1. The modified Hall method is a rapid procedure with an acceptable precision and accuracy for the determination of elemental sulfur present in complex compositions along the guanidine nitrate process line.
2. The determination of total sulfates in a solution of free sulfuric acid and sulfate salts by passing the solution through the

hydrogen form of a sulfonic acid resin is rapid and accurate. The standard deviation for sulfate concentrations ranging from 50% to 80% is approximately 1%. The sole restrictions of the method is that sulfate ion must be present in large excess. If nitrate ion is present, a correction may be made from the ultraviolet absorption spectra. Other anions require formulation of salt complexes or volatilization.

3. A simple, rapid method for analyzing cyanamide in the guanidine nitrate reaction liquor has been developed. This method is based on the reaction of cyanamide and the sodium nitroprusside-potassium ferricyanide-ammonia reagent to form an intensely colored complex, which is subsequently determined spectrophotometrically at 525 nm. This method requires a reaction time of 16 minutes, and the complete analysis including sample preparations can be accomplished in about 20 minutes. This method is, therefore, suitable for on-line process and quality control of the continuous nitroguanidine manufacturing plant being completed at Sunflower Army Ammunition Plant. The relative standard deviation and the relative error were found to be about 1% and -2%, respectively.

4. A systematic investigation of the effects of various component species in the guanidine nitrate reactor liquor revealed that the combined effects on the absorption characteristics of the cyanamide-reagent complex can be quantitatively accounted for in terms of the formation of guanidinium-reagent complex and the dissociations of both cyanamide and guanidinium ion-reagent complexes by ammonium ion.

5. The interference studies also established the feasibility of employing the developed method for analyzing not only the single component systems, i.e., cyanamide and guanidinium ion, but also the rapid, simultaneous multi-component analyses of any combinations of two key ingredients or all three ingredients, namely, cyanamide, guanidinium ion, and ammonium ions in mixtures containing calcium nitrate and dicyandiamide.

6. Direct, rapid, ultraviolet absorption spectrophotometric determination of cyanamide in the guanidine nitrate reactor liquor cannot be accomplished owing to the weak absorption of cyanamide and the presence of large amounts of nitrate ion which absorbs intensely in the absorption range of cyanamide.

7. Ion chromatography has shown direct applicability to various nitroguanidine process streams. Multi ionic samples can be separated and quantified in a relatively short period of time with no sacrifice in either precision or accuracy. This represents a considerable manpower saving when compared to classical methods of chemical analysis.

RECOMMENDATIONS

Further method developments in the following areas should be conducted to continuously update the current methodologies to achieve the on-line, real-time automated instrumental process and quality controls of the continuous nitroguanidine plant.

1. Develop a rapid, direct method for analyzing cyanamide in the guanidine nitrate reactor liquor employing a newly developed, reverse-optics, microprocessor-controlled rapid scan ultraviolet/visible spectrophotometer.
2. Develop a rapid method for the simultaneous determination of cyanamide, guanidine nitrate, and ammonium nitrate using the rapid scan ultraviolet/visible spectrophotometer.
3. Develop a truly on-line, real-time, automated instrument for analyzing nitroguanidine and nitrate ion in the spent acid liquors using the rapid scan ultraviolet/visible spectrophotometer interfaced with other accessories such as the automatic sampler, diluter, and injector.
4. Determine the feasibility of analyzing sulfide in the carbonate liquor using rapid scan ultraviolet/visible spectrophotometer.
5. Develop a rapid method for determining cyanamide and dicyandiamide using high pressure liquid chromatography.
6. Since all solutions used in this study were not from actual process streams two items should be considered. First the dilution factors listed for samples prior to introduction into the IC should only be used as approximate guides because actual percentage composition will be known only when the process streams are operational.
7. Consideration must be given to the solids and particulates present in samples taken from the various process streams. Nearly all samples will have to be filtered prior to analysis to remove carbon, sulfur, and other insoluble materials. Failure to remove particulates will result in rapid plugging of the IC columns.

REFERENCES

1. Maynard E. Hall, Analytical Chemistry, vol 22, no. 9, p 1139.
2. Drawing No. 37-01-15, Sunflower Army Ammunition Plant, Lawrence, Kansas, April 1975.
3. J.F. Alicino, Analytical Chemistry, vol 20, 1948, p 85.
4. C.L. Ogg, C.O. Willets, F.J. Cooper, Analytical Chemistry, vol 20, 1948, p 83.
5. A. Steyermark, E. Ban, B. Littman, Analytical Chemistry, vol 20, 1948, p 857.
6. M.W. Giles, W.H. Kaylor, J.E. Longbottom, Analyst, 1968, p 93, 97.
7. R.J. Bertotacini, H.E. Barnety, Analytical Chemistry, 1957, p 281.
8. T.H. Chen, Propellants and Explosives, vol 4, 1979, p 17.
9. T.A. Nieman, et al, Analytical Chemistry, vol 48, 1976, p 899.
10. T.H. Chen, Explosives and Propellants, vol 4, 1979, p 18.
11. Ibid, p 19.
12. B.G. Willis, et al., Hewlett-Packard Journal, vol 31, 1980, pp 3-31.
13. H.L. Thomas, Industrial Research/Development, July 1979, pp 86-91.
14. P.J. Elving, I.M. Kolthoff eds., "Chemical Analysis, A Series of Monographs on Analytical Chemistry and Its Applications," vol 28, C.A. Streuli, P.R. Averell, eds., "The Analytical Chemistry of Nitrogen and Its Compounds," Part 2, Wiley-Interscience, NY, 1970, pp 519-524.
15. M. Takimoto, K. Koeda, Kogyo Kagaku Zasshi, vol 63, 1960, p 797.
16. M. Takimoto, M. Sawada, Kogyo Kagaku Zasshi, vol 63, 1960, p 967.

17. D.A. Buyske, V. Downing, Analytical Chemistry, 1960, p 1798.
18. Yu. I. Mushkin, Zavod. Lab., vol 33 (3), 1967, p 296 (Russ)., C.A. vol 67, p 39959 C.
19. G.H. Buchanan, G. Barksy, J. Am. Chem. Soc., vol 52, 1930, p 195.

Table 1. Percent compositions containing elemental sulfur along the guanidine nitrate manufacture line*

<u>Components</u>	<u>Precipitator slurry</u>	<u>Evaporated liquor</u>	<u>Mother liquor</u>	<u>Clear liquor</u>	<u>Reactor liquor</u>	<u>AN liquor</u>	<u>Neutral liquor</u>	<u>Magma</u>
Ca(NO ₃) ₂	0.2		0.2	0.3	25.8	0.4	0.2	0.2
AN	41.6	74.9	46.6	44.3	39.0	75.2	43.8	44.4
(NH ₄) ₂ CO ₃	0.3			0.3				
GH	13.4	7.8	5.0	14.1	20.5		13.1	13.3
H ₂ O	32.8	16.8	48.1	40.3	11.4	16.9	42.8	42.0
CaCO ₃	9.6							
Solids	0.3				0.5			
Sulfur	0.1	0.1	0.1	0.1	0.1	0.1	0.1	0.1
HN ₃	0.5			0.6	0.8			
C	1.2				1.9			

* Reference 2

Table 2. Polarographic determination of free sulfur in synthetics simulating a composition in the guanidine nitrate line

<u>Determination no.</u>	<u>Percent sulfur</u>	
	<u>found</u>	<u>added</u>
1	0.10	0.11
2	0.09	0.11
3	0.09	0.11
4	0.10	0.11
5	0.11	0.11
Average, found	0.10	
Standard deviation	0.016	

Relative error, %, average 9.0 (or 90 ppt)

Elapsed time for analysis - 30 minutes

Table 3. Total sulfate in the synthetic sample at the low stage acid concentration mixture

	<u>Added, %</u>	<u>Found, %</u>
	56.58	56.76
	56.58	57.09
	56.58	58.52
	56.58	58.23
	56.58	56.15
Average	57.39%	
Standard Deviation	1.18%	
Relative error	1.20%	

Table 4. Total sulfate in a synthetic sample simulating the middle stage concentration

	<u>Added, %</u>	<u>Found, %</u>
	73.47	74.60
	73.47	75.60
	73.47	75.60
	73.47	75.62
	73.47	73.40
	73.47	72.40
	73.47	73.40
	73.47	73.80
	73.47	73.20
Average	74.32%	
Standard deviation	1.25%	
Relative error	1.50%	

Table 5. Determination of total sulfate in a synthetic sample simulating the high stage concentration mixture

	<u>Added, %</u>	<u>Found, %</u>
	86.16	87.1
	86.16	87.1
	86.16	87.5
	86.16	87.4
	86.16	87.5
	86.16	87.0
Average	87.3%	
Standard Deviation	1.2%	
Relative error	1.3%	

Table 6. Determination of errors $\text{H}_2\text{SO}_4 + \text{NH}_4\text{SO}_4$

<u>H_2SO_4</u>	<u>Added</u>	<u>$(\text{HN}_4)_2\text{SO}_4$</u>	<u>Titer</u>	<u>Theo. titer</u>
0.100N		mg		
27.95		15.2	31.23	13.16
27.95		15.2	31.27	31.16
27.95		15.2	31.13	31.16
27.95		15.2	31.23	31.16
27.95		15.2	31.13	31.16
27.95		15.2	31.08	31.16

Table 7. Determination of errors $\text{H}_2\text{SO}_4 + (\text{NH}_4)_2\text{SO}_4 + \text{nitroguanidine}$

<u>H_2SO_4</u>	<u>Added</u>	<u>$(\text{HN}_4)_2\text{SO}_4$</u>	<u>NQ titer</u>	<u>Theo. titer</u>
0.100N		mg	40 mg	
27.95		15.2	30.90	31.16
27.95		15.2	30.98	31.16
27.95		15.21	30.90	31.16
27.95		15.2	31.00	31.16
27.95		15.2	30.90	31.16
27.95		15.2	31.15	31.16

Table 8. Determination of errors

<u>H₂SO₄</u>	<u>Added</u>	<u>(NH₄)₂SO₄</u>	<u>NQ titer</u>	<u>QN</u>	<u>Theo. titer</u>
0.100N		mg			
27.95		31.16*	31.16	34.20	34.44
27.95		31.16	31.16	34.30	34.44
27.95		31.16	31.16	34.30	34.44
27.95		31.16	31.16	34.25	34.44
27.95		31.16	31.16	34.10	34.44
27.95		31.16	31.16	34.30	34.40

*Calculated

Table 9. Accuracy and precision data of ions analyzed by IC

<u>Solution</u>		<u>% Composition</u>	<u>Precision (2 Sigma)</u>	<u>Accuracy % Recovery</u>
Carbonate Liquor	CO_3^-	20.3	0.238	98.0
		24.4	0.206	97.6
		30.1	0.180	102.4
Aqua Ammonia	CO_3^-	0.50	0.018	102.3
		1.11	0.018	102.8
		1.99	0.071	110.0
		Total:	5.56	0.096
Decanter wash	NH_4^+	4.90	0.056	99.6
	* Gu^+	1.56	0.033	97.4
Absorber feed	NH_4^+	7.74	0.147	99.4
	Gu^+	2.54	0.060	99.2
Middle Stage Concentrator	SO_4^-	75.54	0.935	100.52
Low Stage Concentrator	SO_4^-	60.19	0.348	101.2
	NO_3^-	0.804	0.01	102.4
Reactor Liquor	NH_4^+	42.5	0.175	105.8
	GU^+	21.0	0.249	96.9
	Ca^{+2}	24.4	0.133	97.8
Decanter Sludge (0.8 mL of 1N HNO_3 used to dis- solve CaCO_3)	NH_4^+	10.0	0.027	106.3
	Gu^+	3.2	0.57	98.2
	Ca^{+2}	38.7	0.014	101.4

*Guanidinium Ion

Table 10. Data for the determination of sulfate in nitroguanidine

<u>Eluent</u>	<u>% SO₄⁻² Added</u>	<u>Precision (2 Sigma)</u>	<u>Accuracy</u>
0.0020M NaHCO ₃ 0.0024M Na ₂ CO ₃	0.20	0.007	99.5
0.0030 NaHCO ₃ 0.0015 Na ₂ CO ₃	0.20	0.005	103.3

Table 11. Compositions of the guanidine nitrate liquor discharged from the first reactor (no. 4 line in the Hercules flow chart) and the synthetic mixture

<u>Compounds</u>	<u>Composition</u>		
	<u>Liquor</u>		<u>Synthetic mixture</u>
	<u>Wt. %</u>	<u>Rel. wt, mg</u>	<u>mg</u>
S	0.0804	0.008	0.018
Ca(NO ₃) ₂	18.60	1.86	3.076
H ₂ O	12.30	1.23	2000.
CaNCN	2.20	~ 0.11 ^a	~ 0.05 ^{b,c,d}
C	1.80	0.18	0.215
Guanidine			
Nitrate	16.70	1.67	1.759
NH ₄ NO ₃	46.20	4.62	4.620
NH ₃	0.50	0.05	(2)
Misc.	1.62	0.16	-

^aThese values represent H₂NCN rather than CaNCN.

^bNH₃ is already contained in the reagent.

^cThe cyanamide reagent is contaminated with about 50% dicyandiamide.

^dA synthetic mixture without the addition of cyanamide was also prepared.

Table 12. Analysis of cyanamide in the synthetic mixture

<u>Exp. no.</u>	<u>Cyanamide Concentration</u>	
	<u>Added</u>	<u>Found</u>
1	10.0	9.73
2	10.0	9.91
3	10.0	9.79
4	10.0	9.75
5	10.0	9.70
6	10.0	9.78
	Average	9.78

Standard deviation: 0.077
 Relative stand deviation: 0.79%
 Relative error: -2.2%

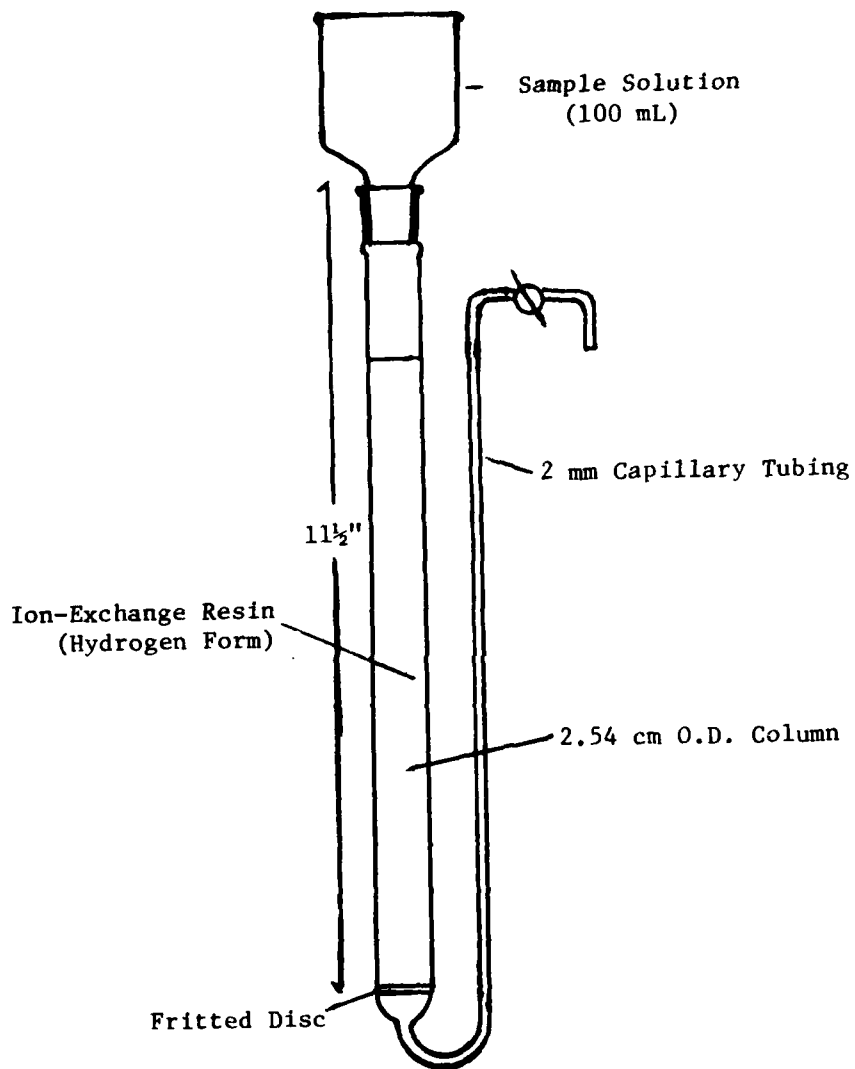

Figure 1. Ion-exchange apparatus for sulfate determination

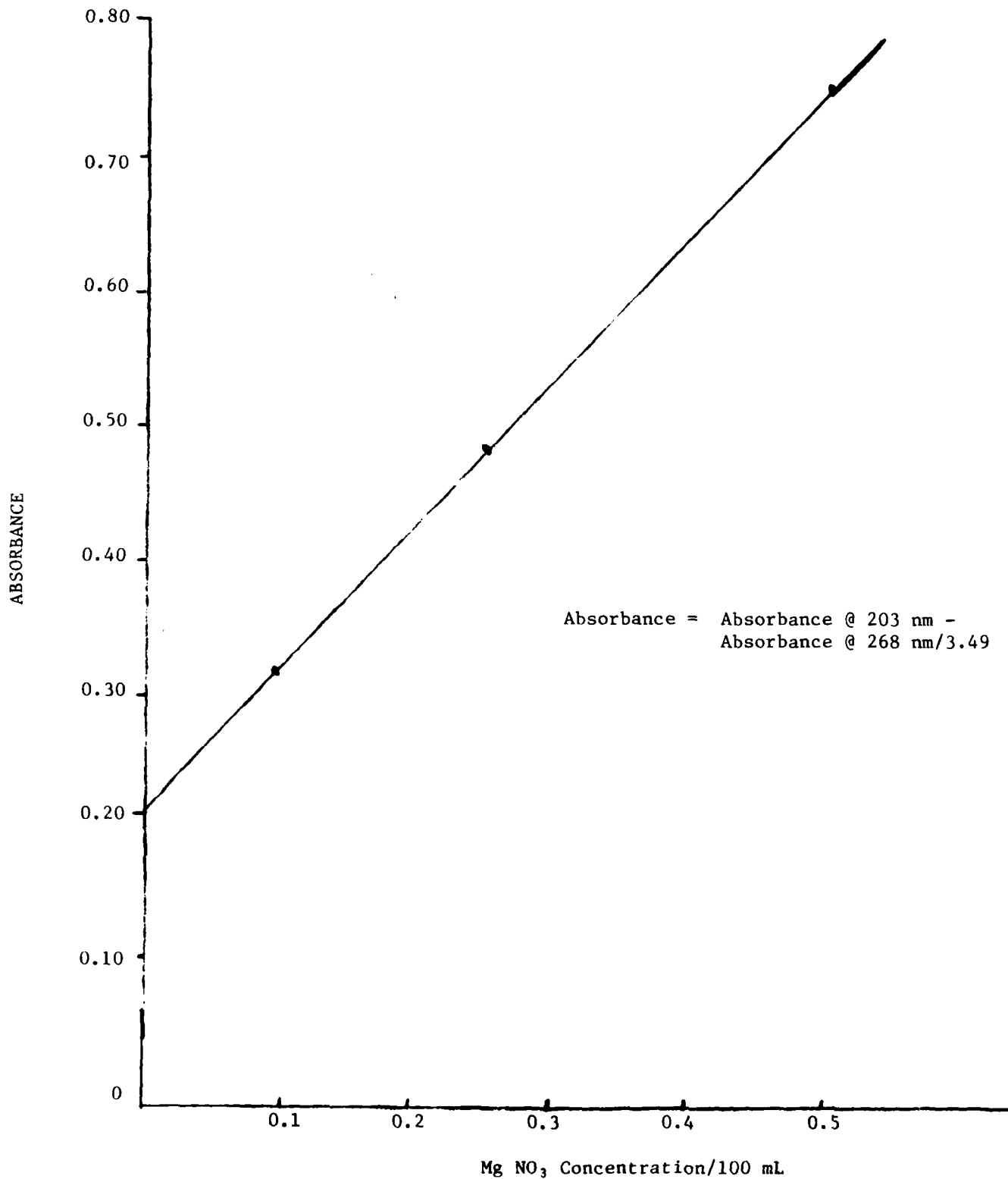

Figure 2. Calibration curve for nitrate ion

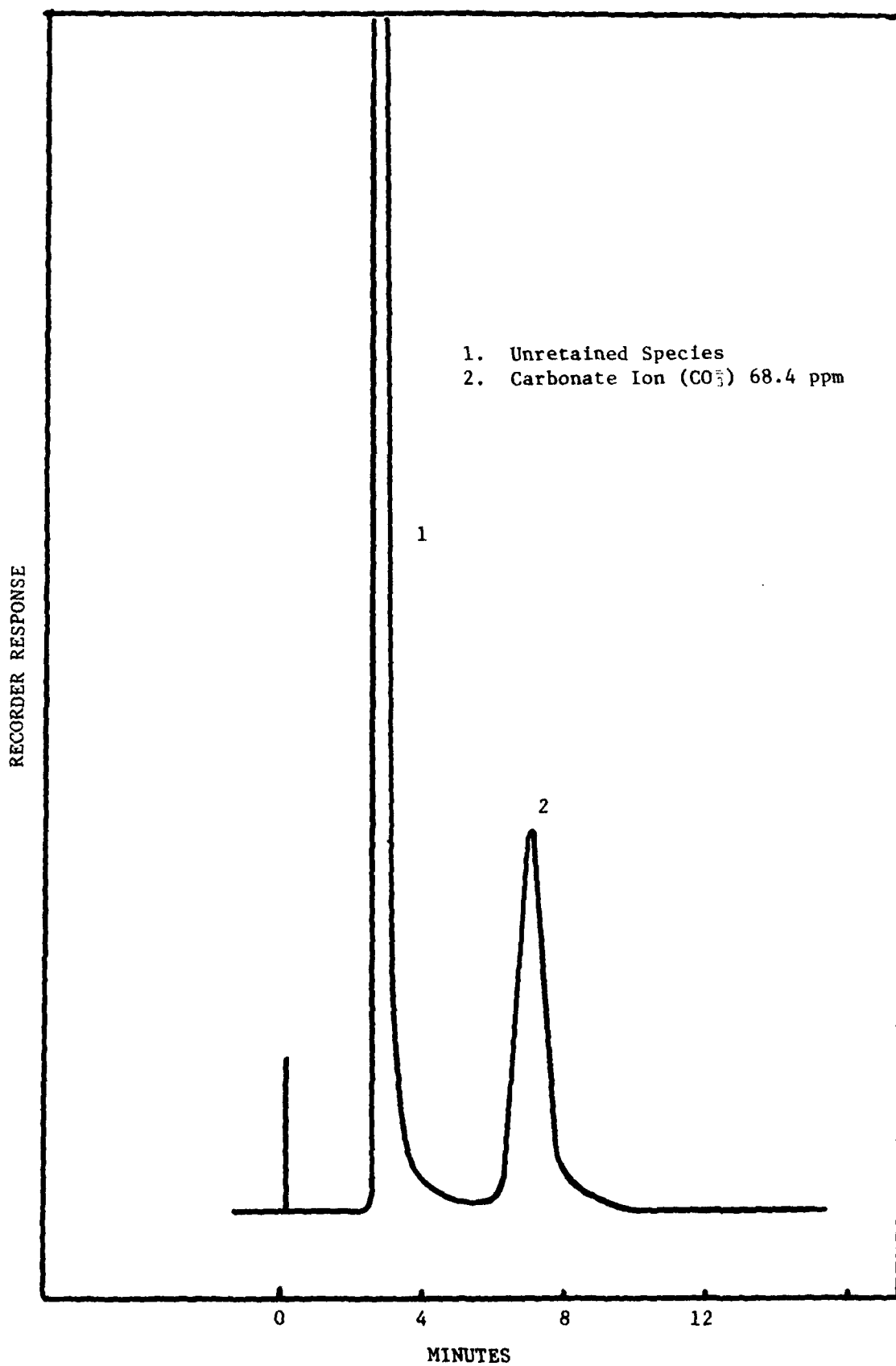

Figure 3. Carbonate ion in carbonate liquor

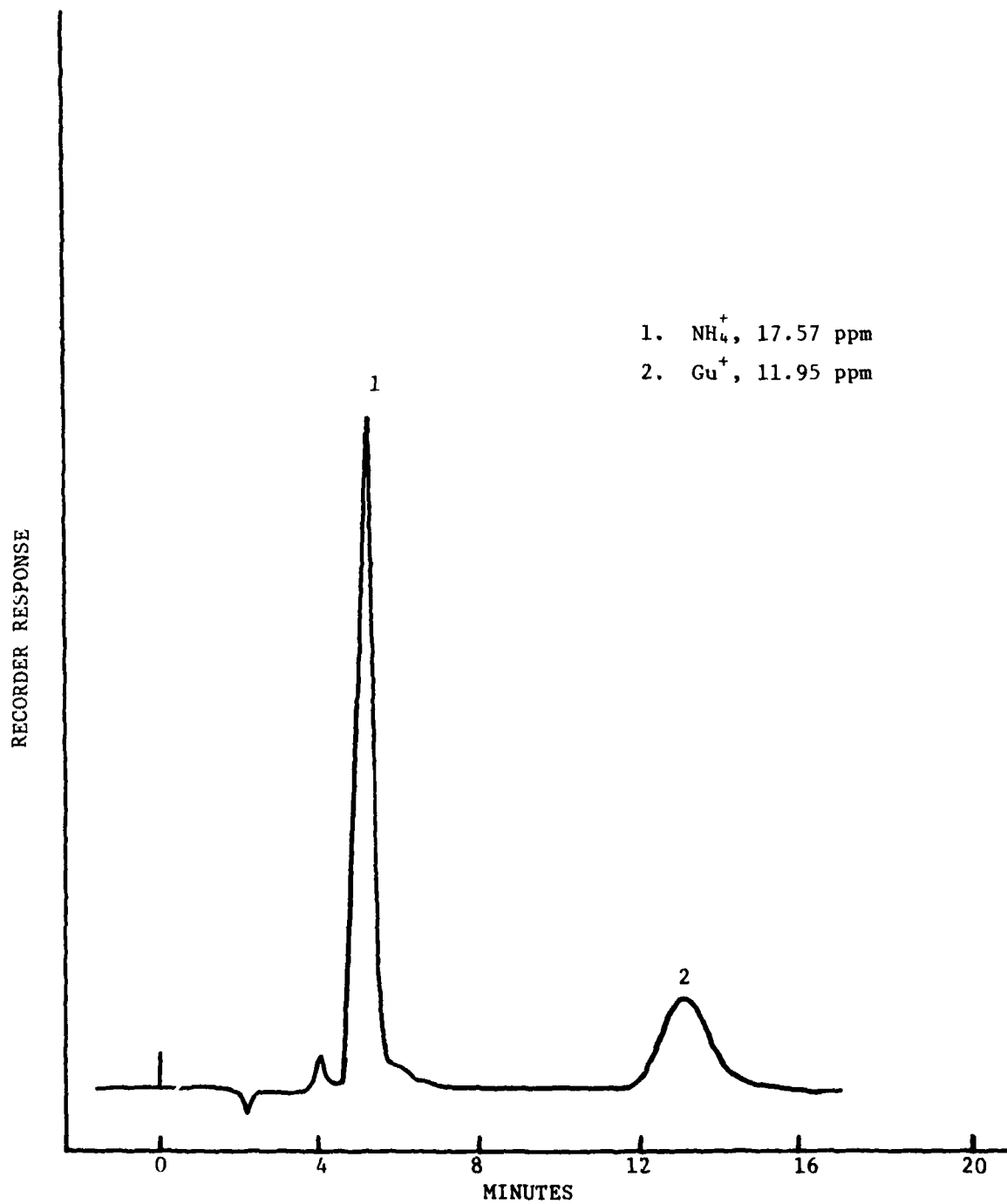

Figure 4. Ammonium and guanidinium ions in decanter wash

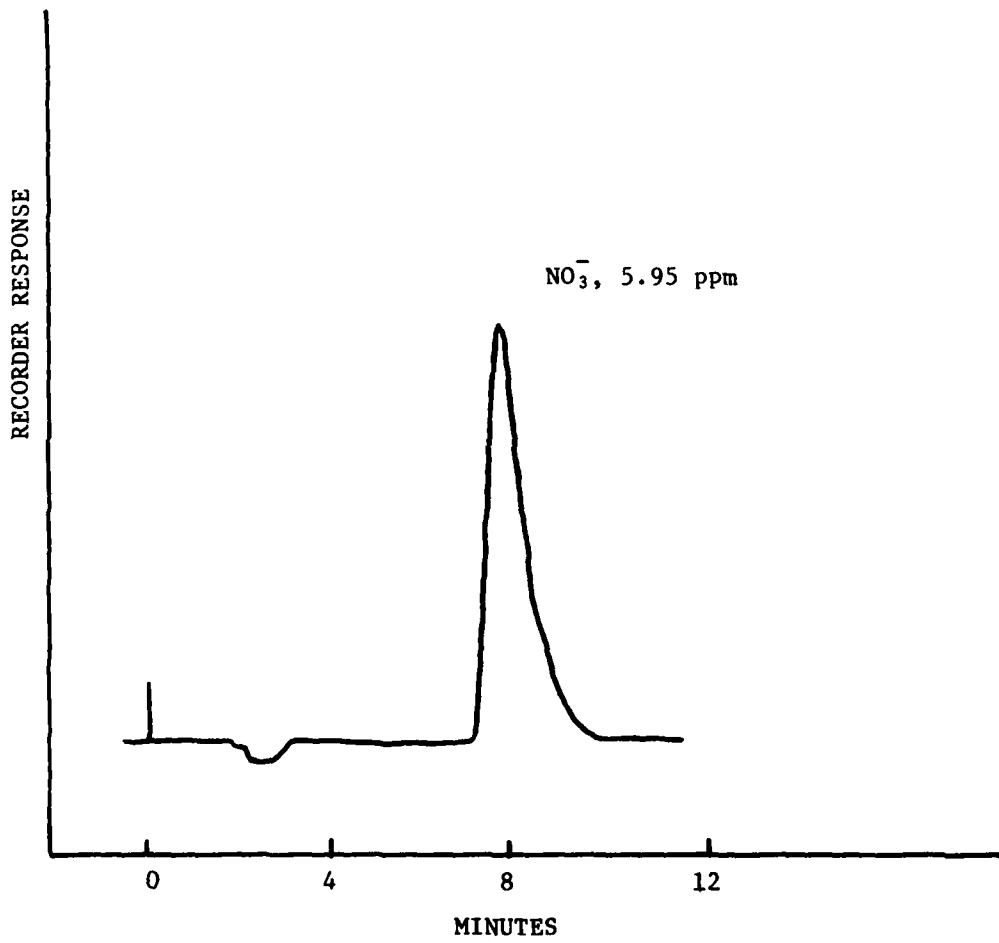

Figure 5. Total nitrate in aqua ammonia

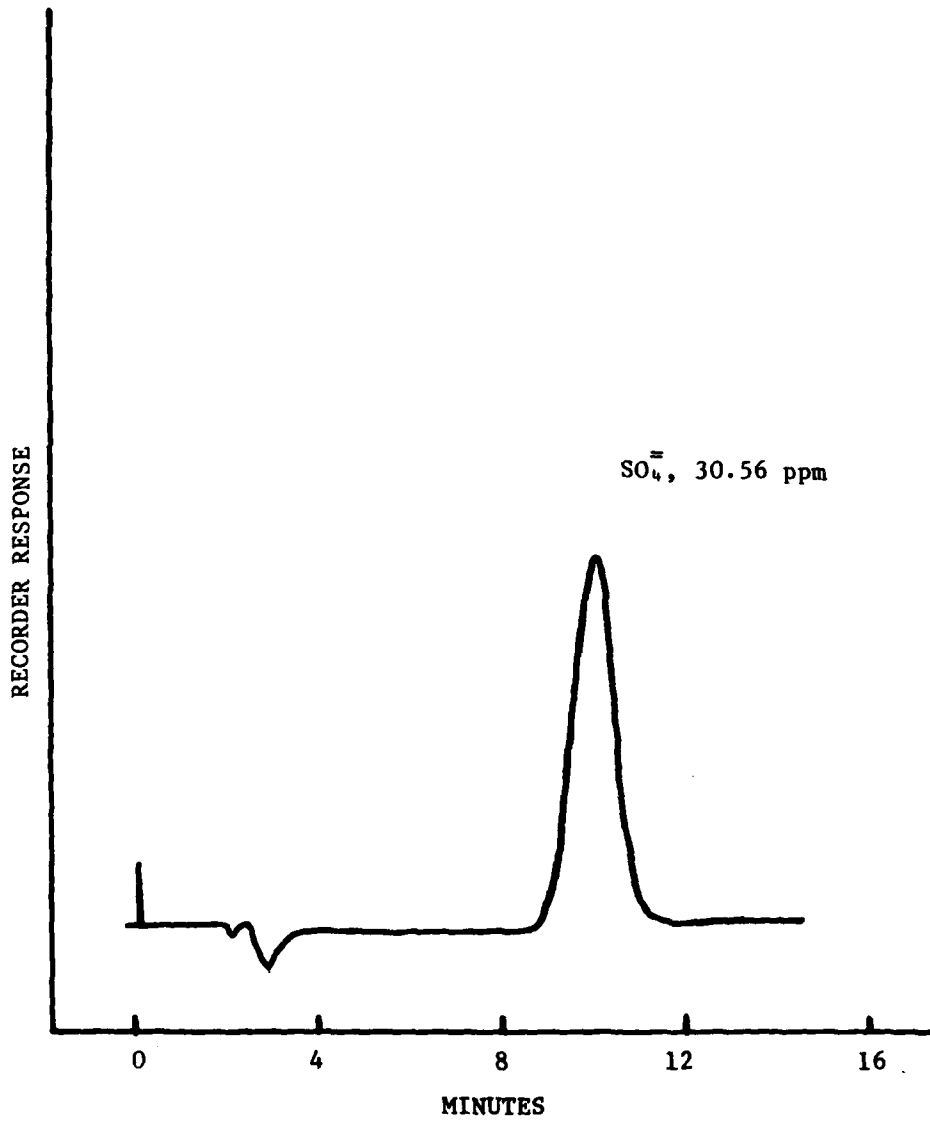

Figure 6. Sulfate in mid stage concentrator

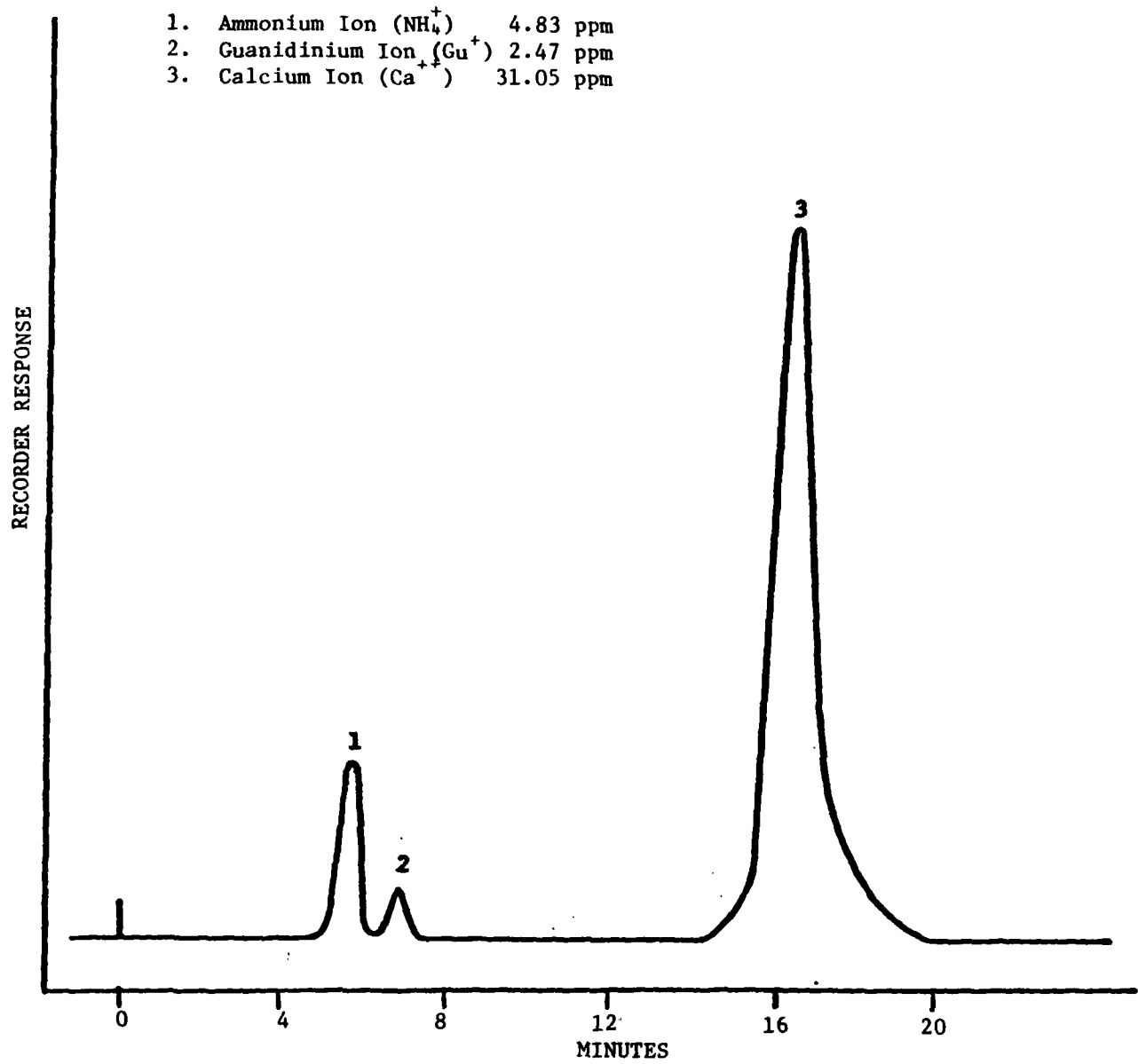

Figure 7. Ion chromatogram of a decanter sludge

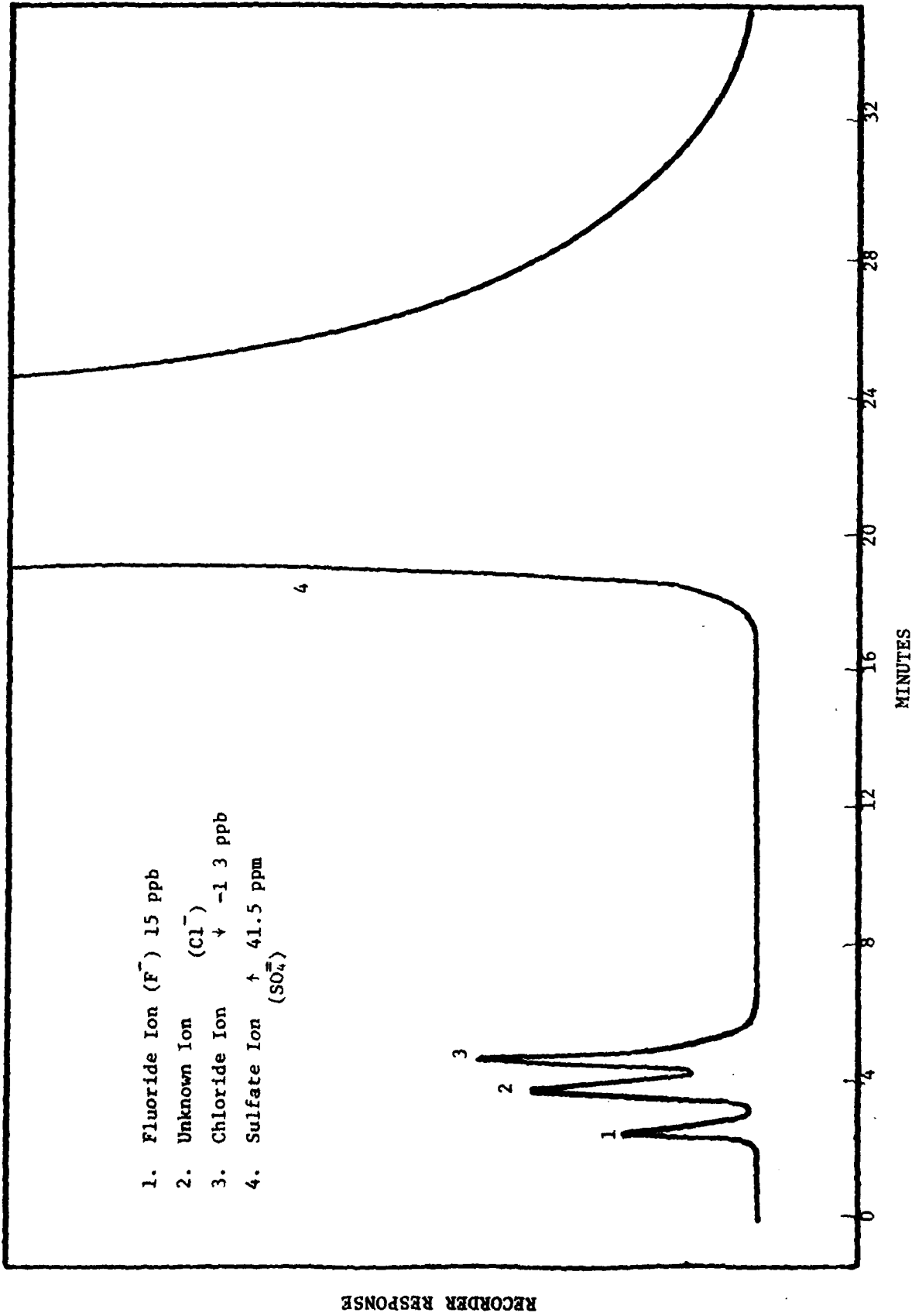

Figure 8. Minimum F^- determination in presence of SO_4^{2-}

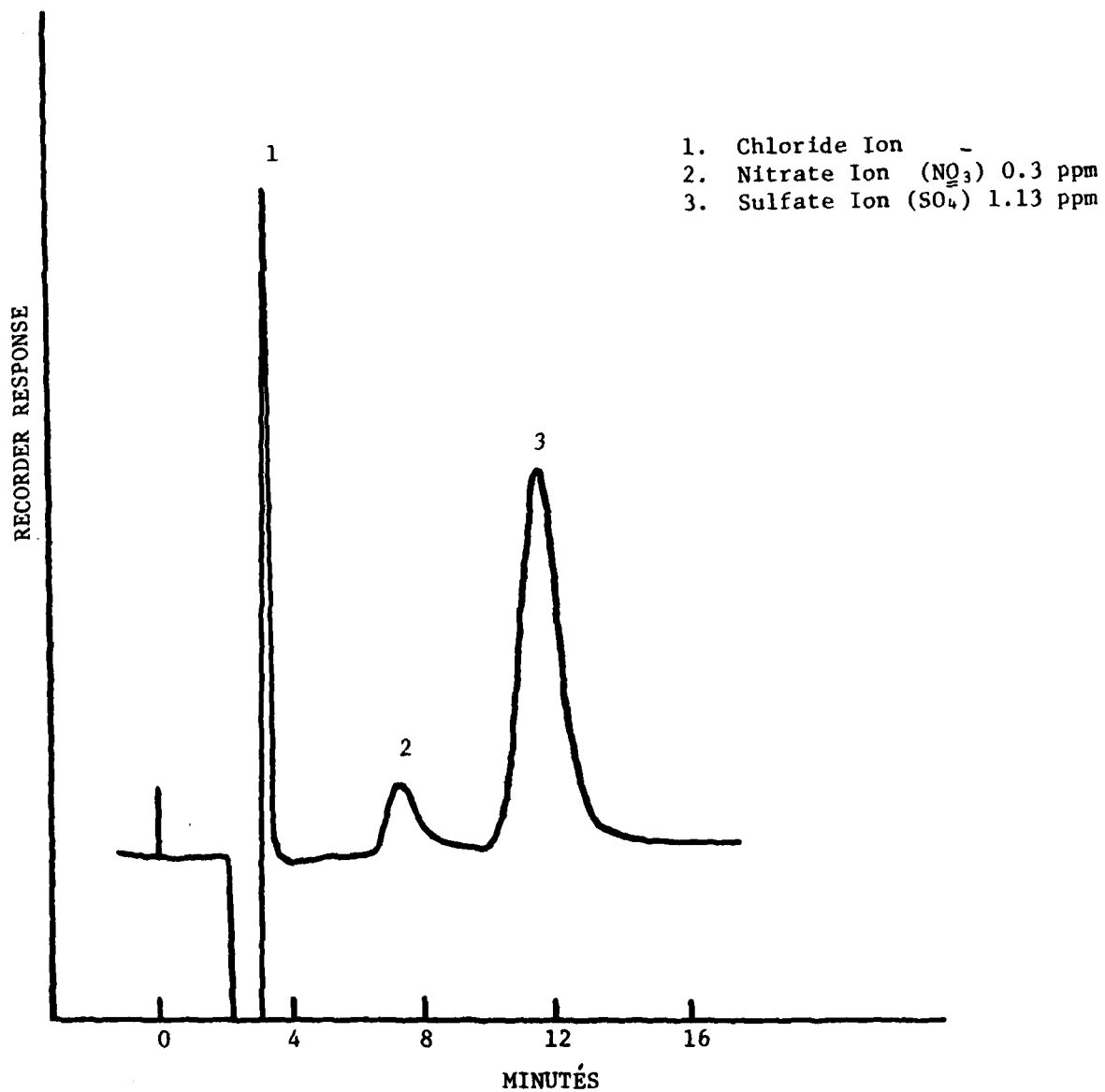
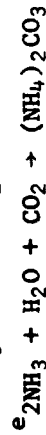
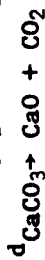
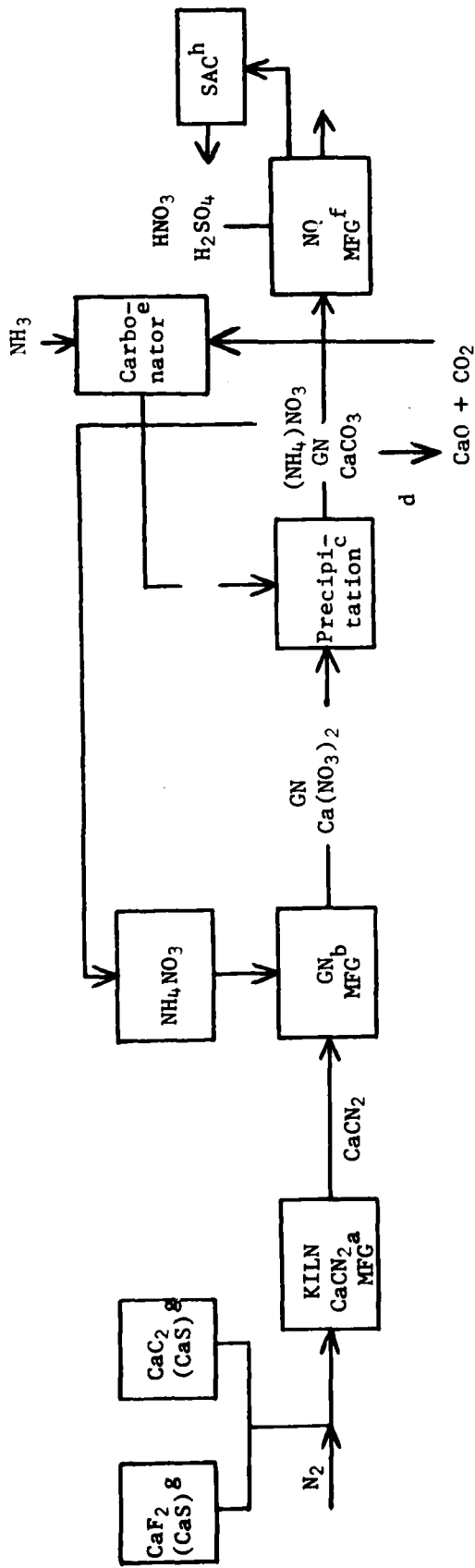

Figure 9. Sulfate and nitrate content



^g Impurities include CaS, the sources of sulfur and sulfide in various streams

^h Spent acid concentrators

Figure 10. Continuous nitroguanidine process at SFAAP

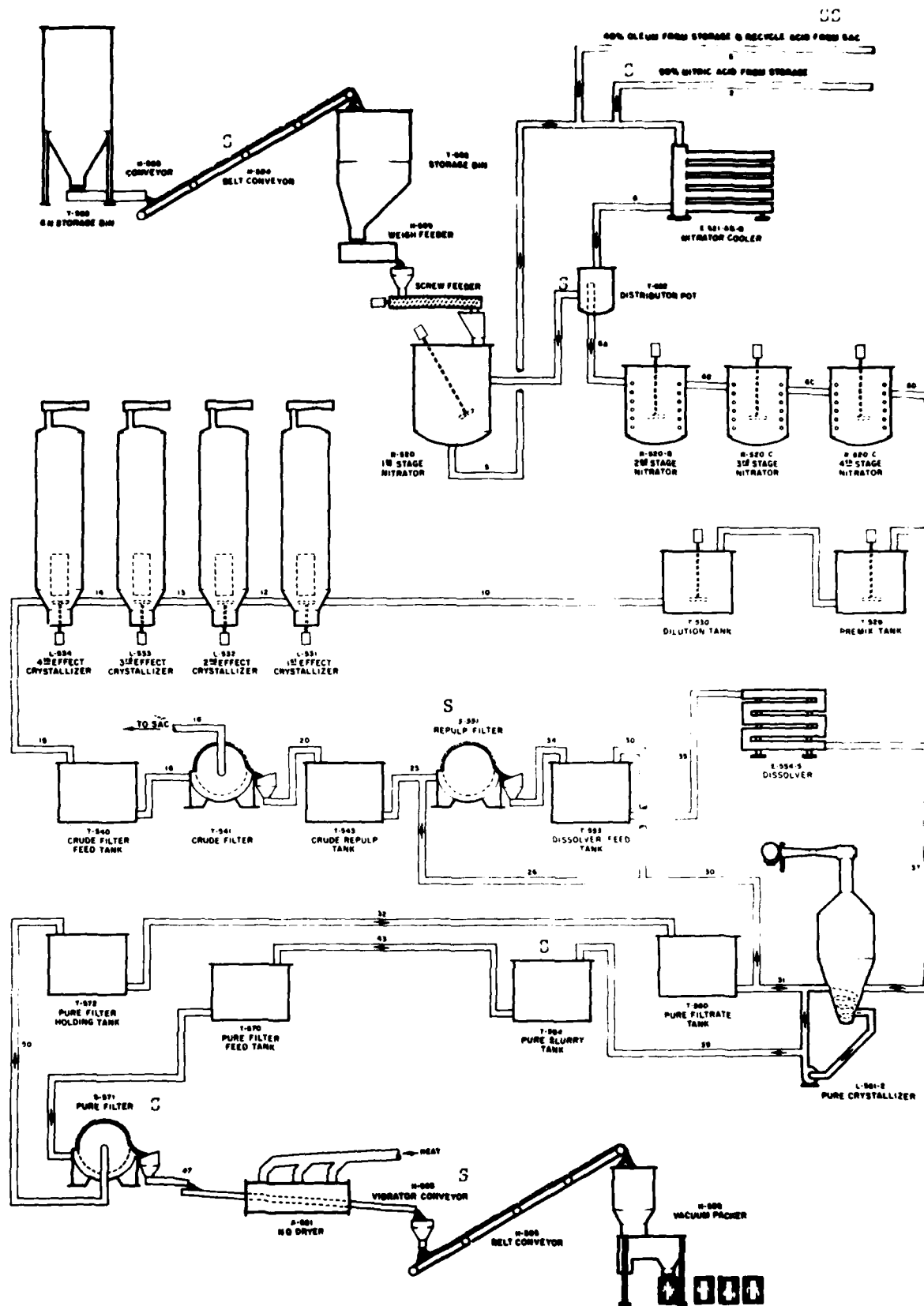

Figure 11. Nitroguanidine process flow diagram

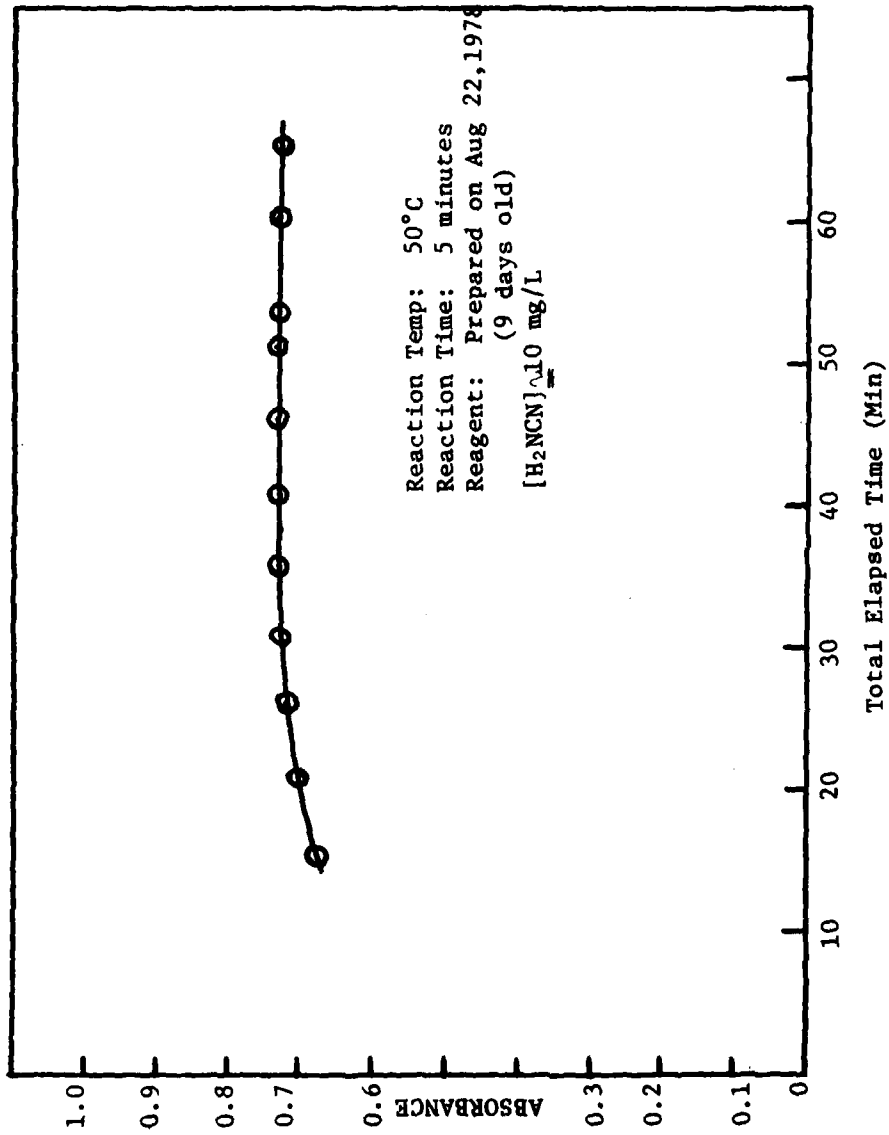

Figure 12. Reaction of H_2NCN with $Na_2[Fe(CN)_5NO] \cdot 2H_2O \cdot K_3[Fe(CN)_6] - NH_3$ reagent

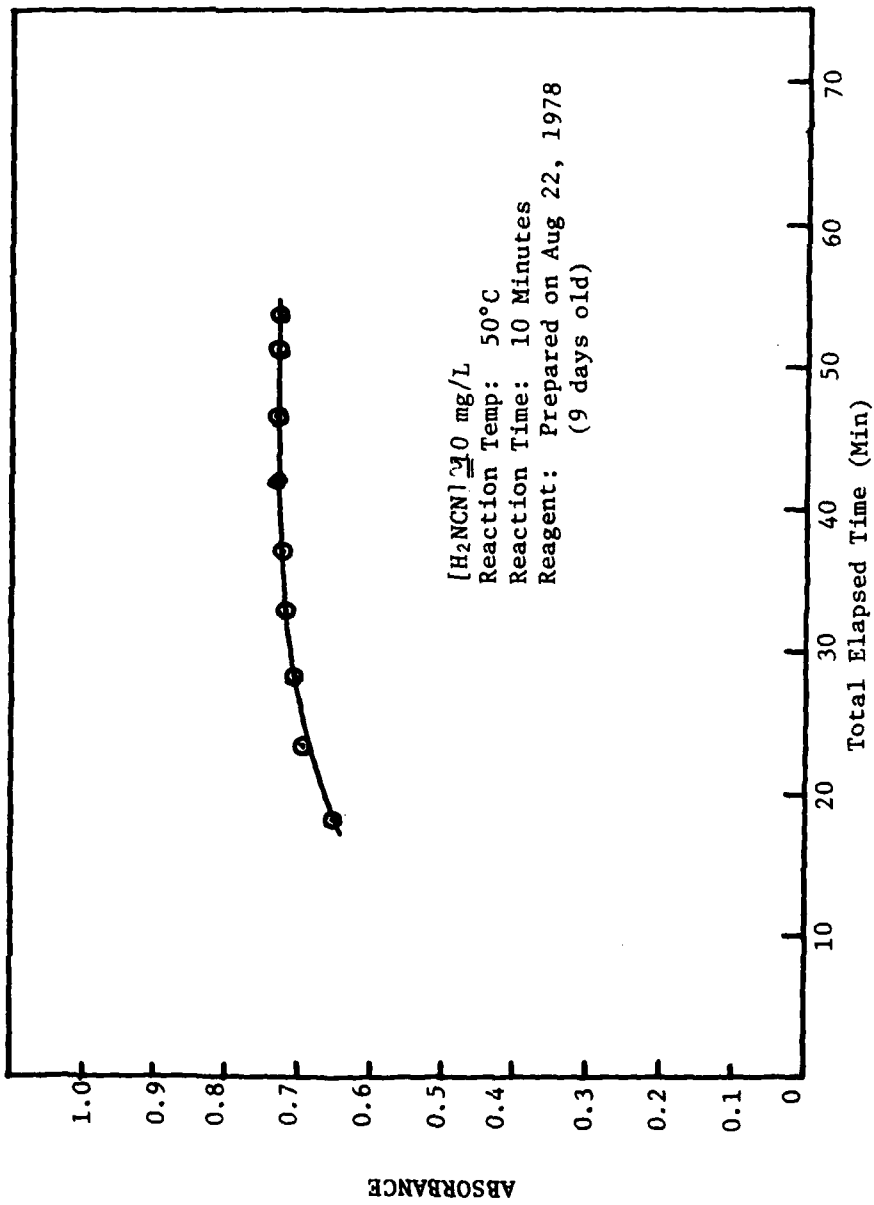

Figure 13. Reaction of H_2NCN with $Na_2[Fe(CN)_5NO] \cdot 2H_2O - K_3[Fe(CN)_6] - NH_3$ reagent

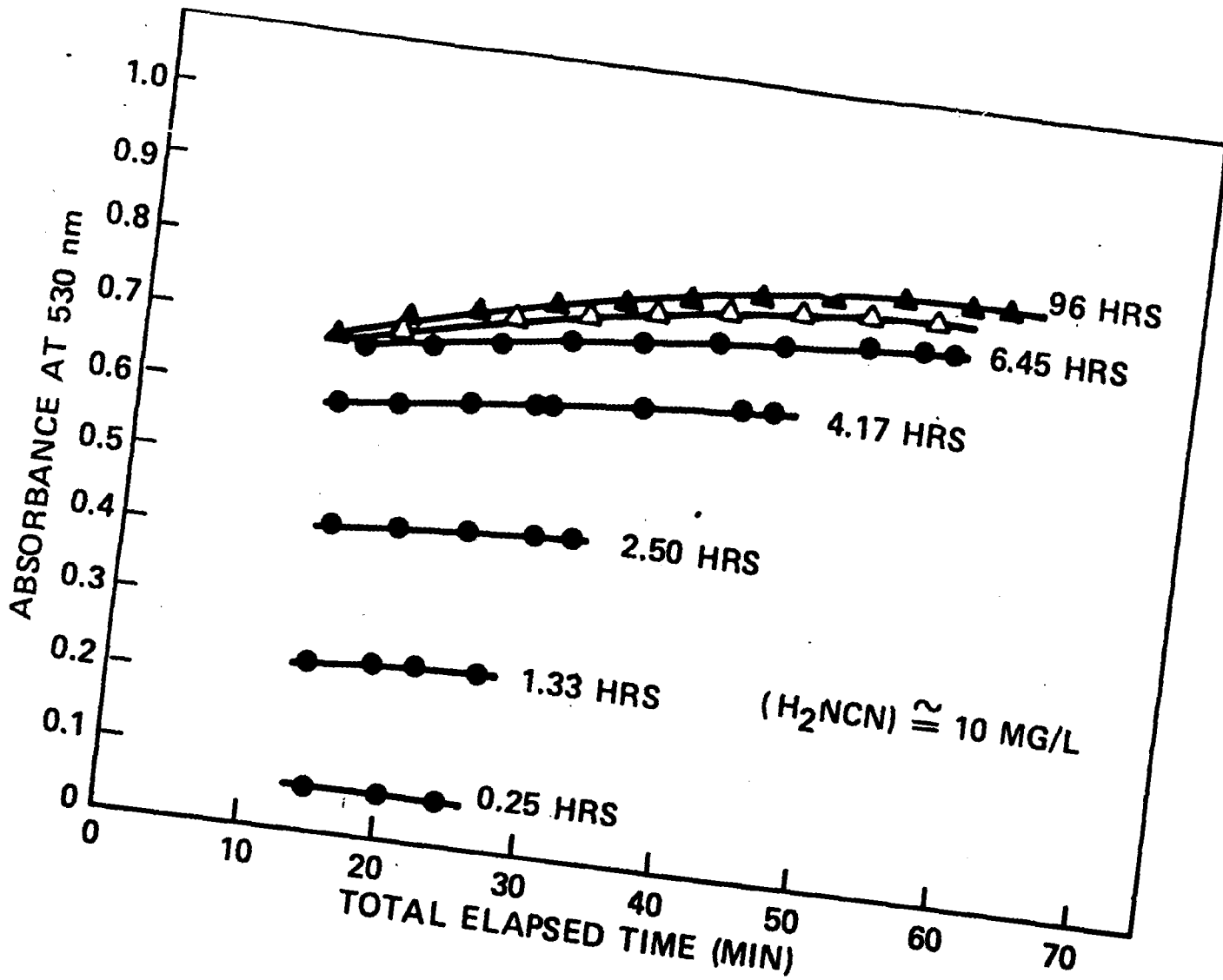

Figure 14. Effect of reagent standing time on complex formation

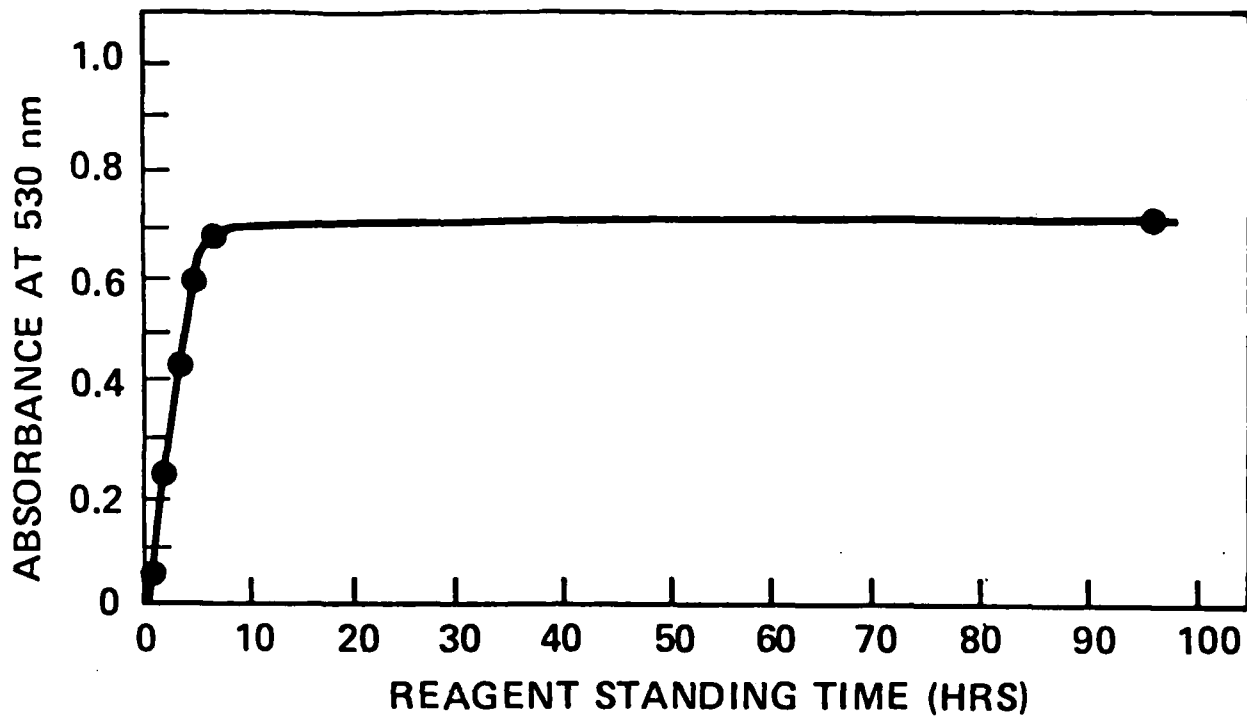

Figure 15. Effect of reagent standing time on complex formation-absorbances were obtained at 20 minutes total elapsed time

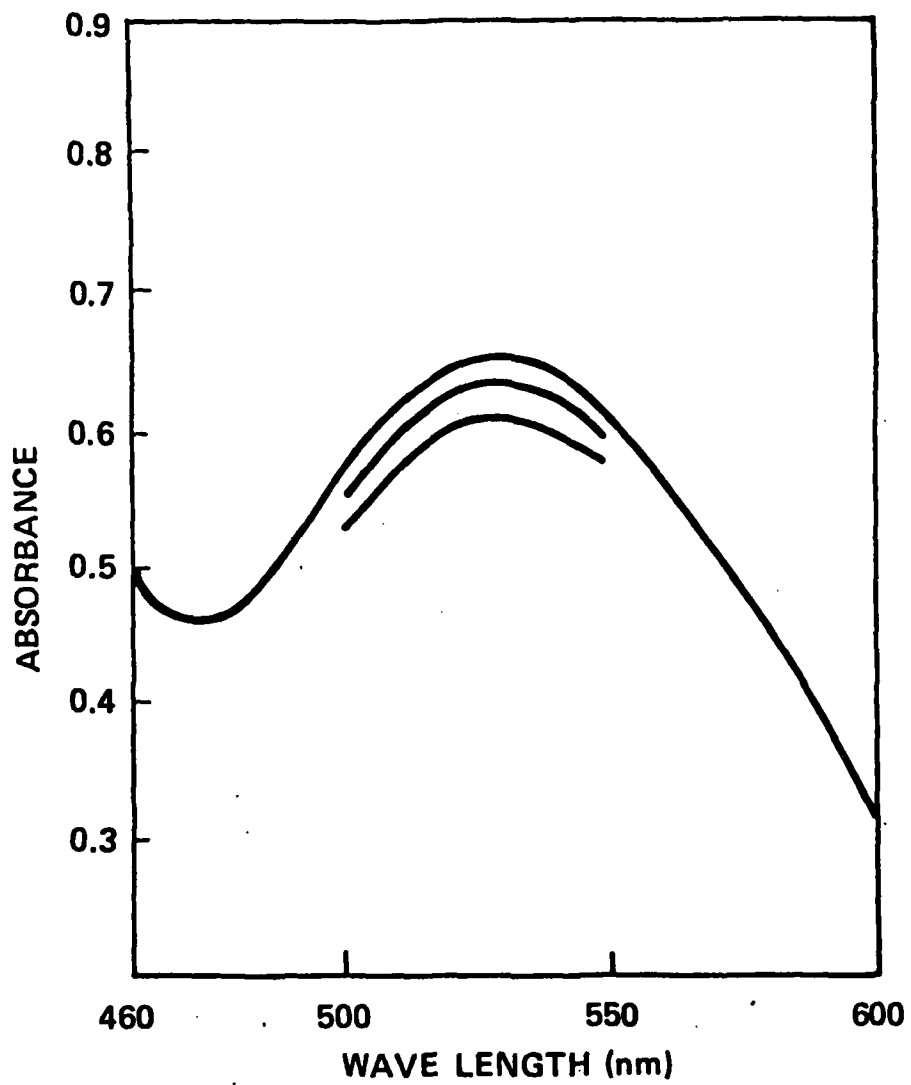

Figure 16. Absorption spectra of cyanamide reagent complex

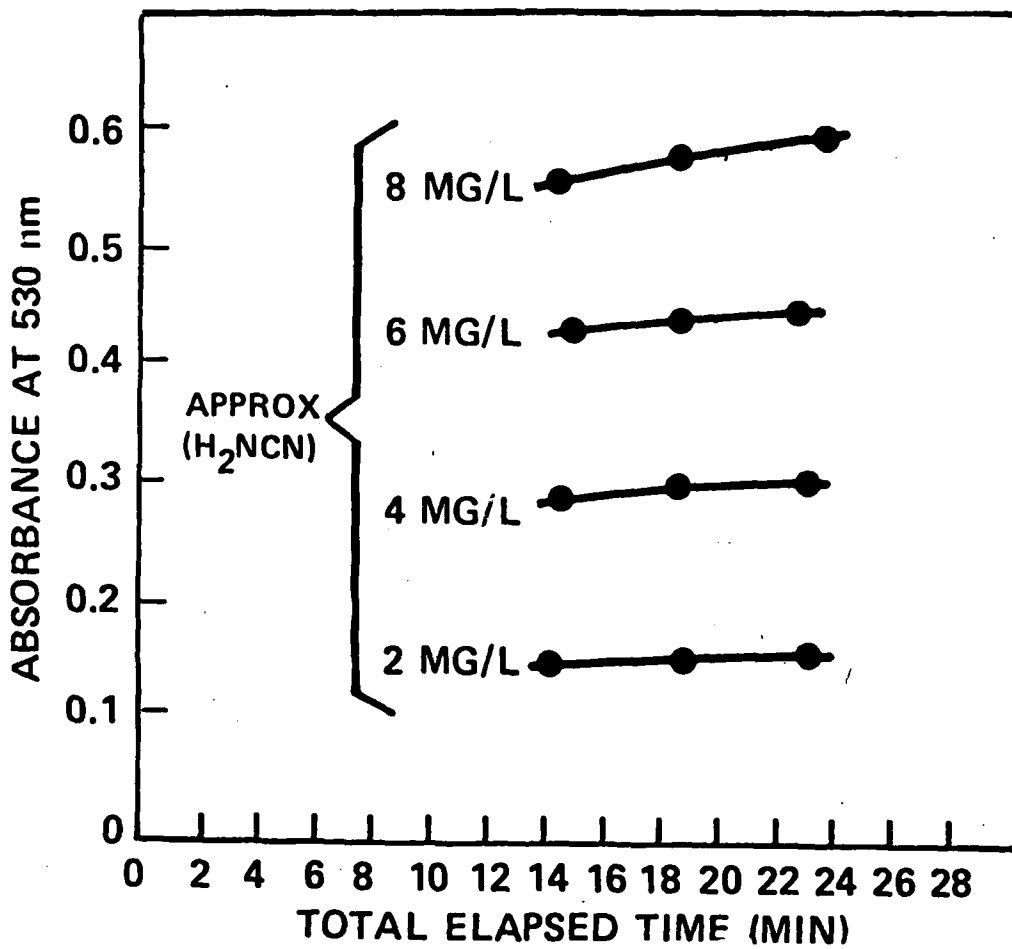

Figure 17. Reaction of H₂NCN with Na₂[Fe(CN)₅NO]2H₂O-K₃[Fe(CN)₆]-NH₃ reagent

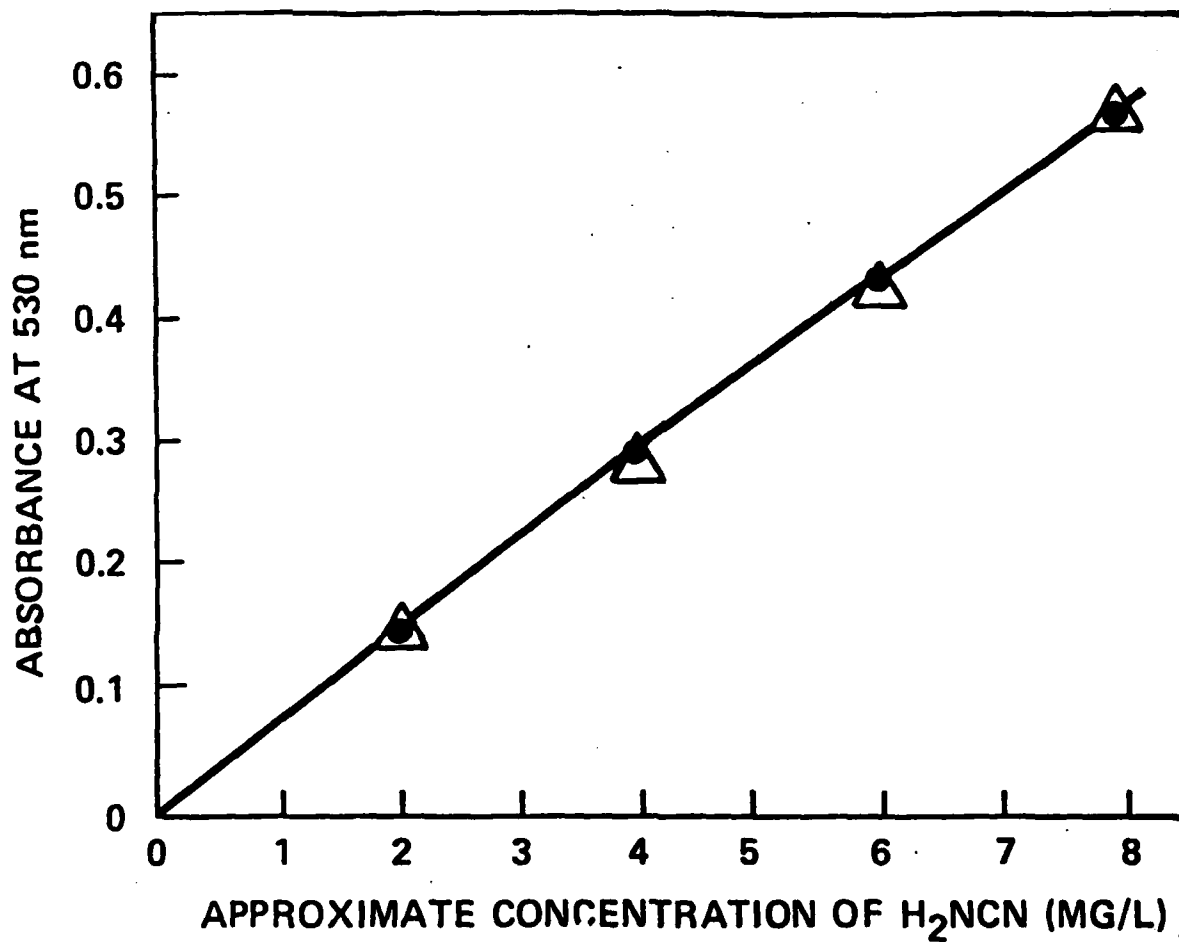

Figure 18. Calibration curve for the determination of cyanamide-absorbances were obtained at 16 min. total elapsed time from two series of experiments (● and Δ)

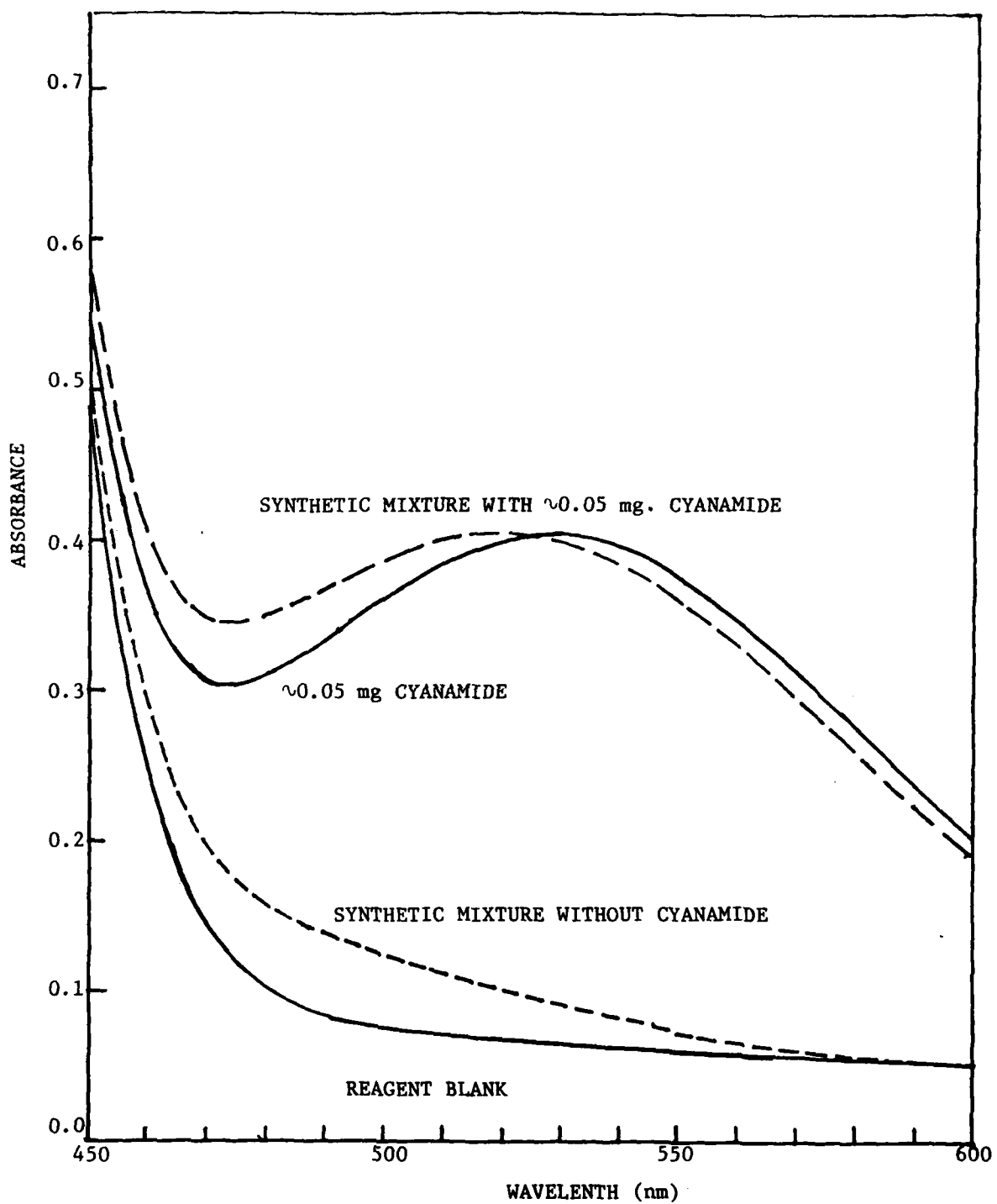

Figure 19. Effect of guanidine nitrate liquor on cyanamide-reagent complex

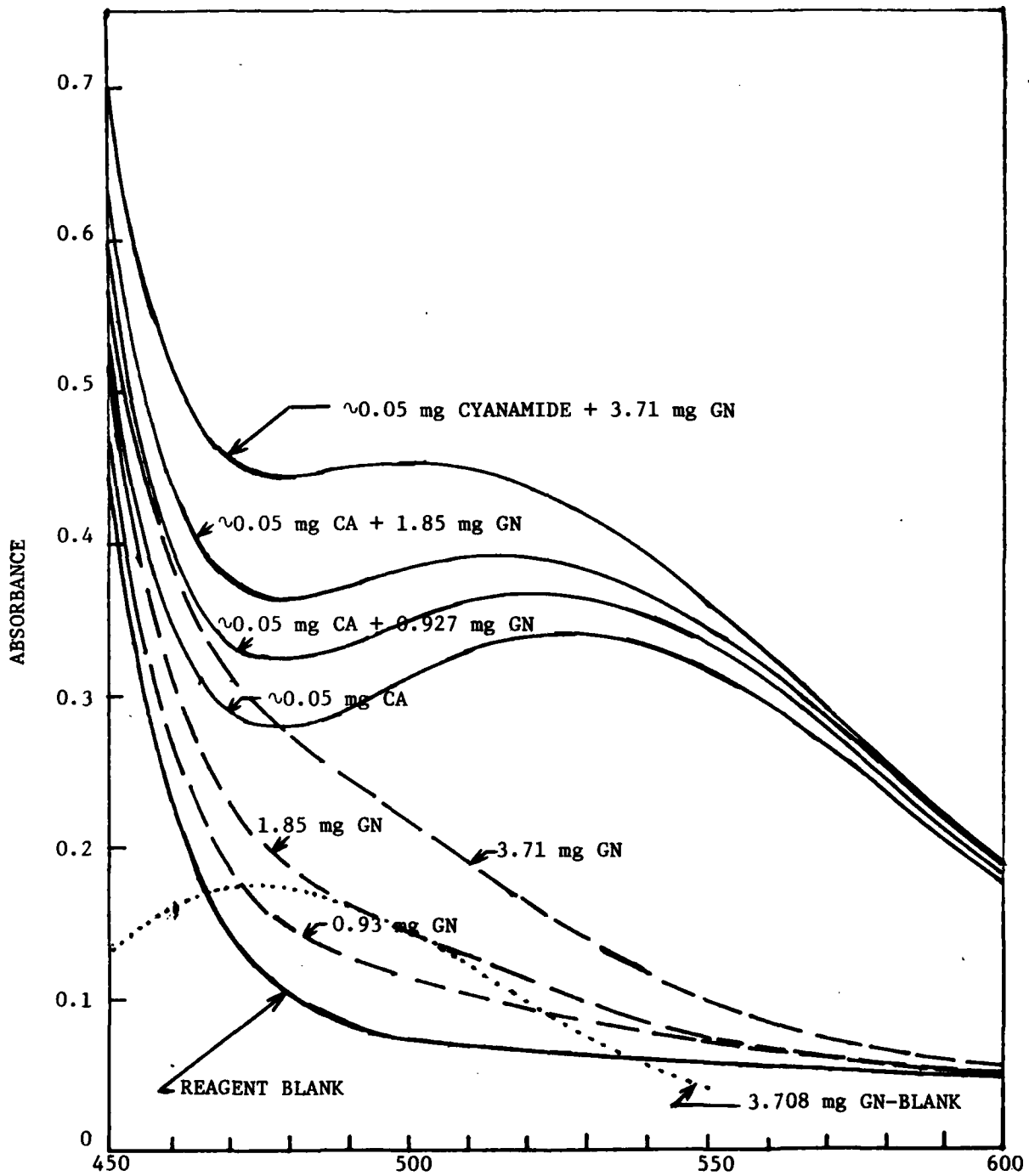
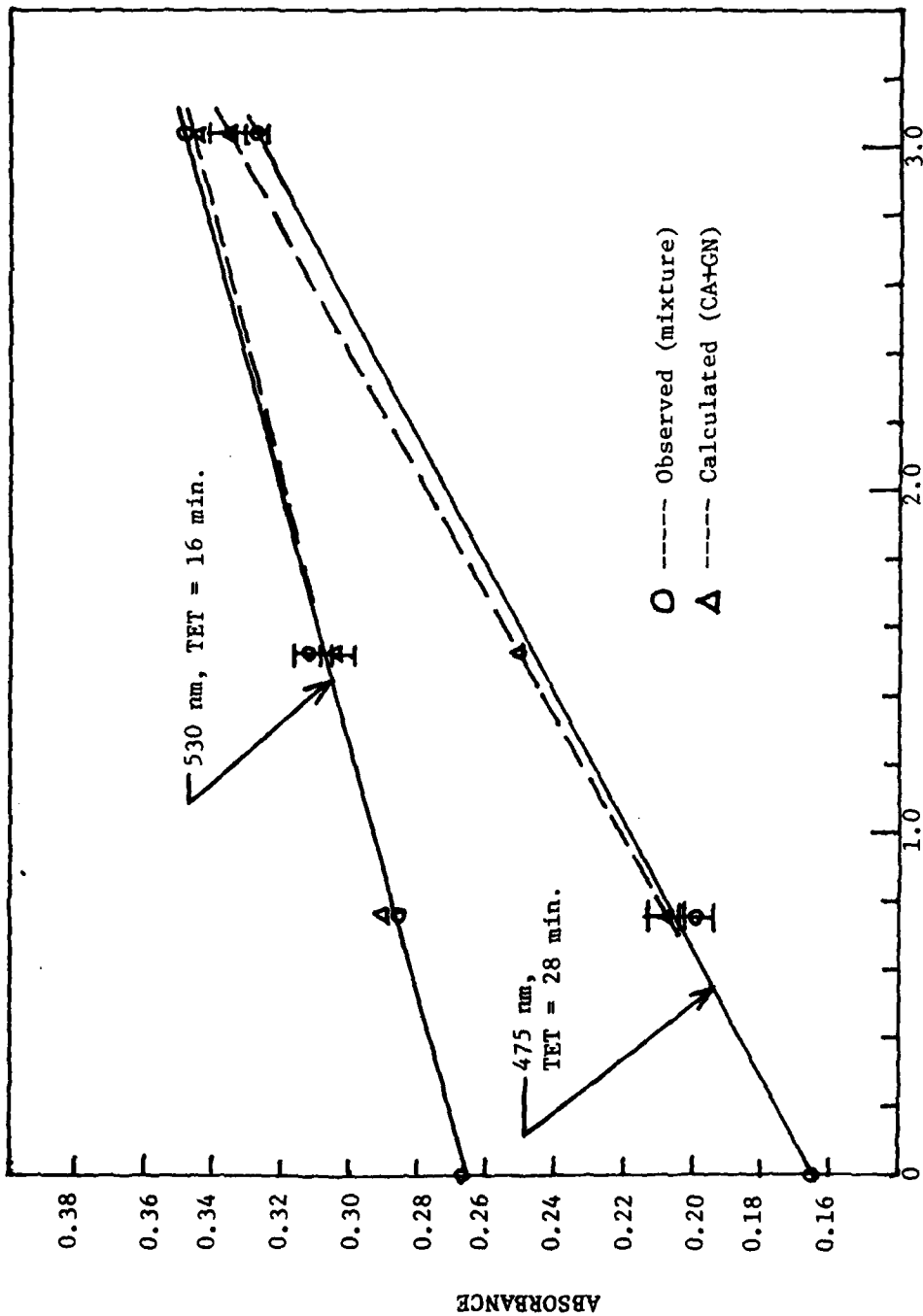

Figure 20. Effect of guanidine nitrate on cyanamide-reagent complex



CONCENTRATION OF GUANIDINE NITRATE IN THE
CYANAMIDE-GUANIDINE NITRATE MIXTURE ($M \times 10^3$)

Figure 21. Effect of guanidine nitrate on cyanamide-reagent complex

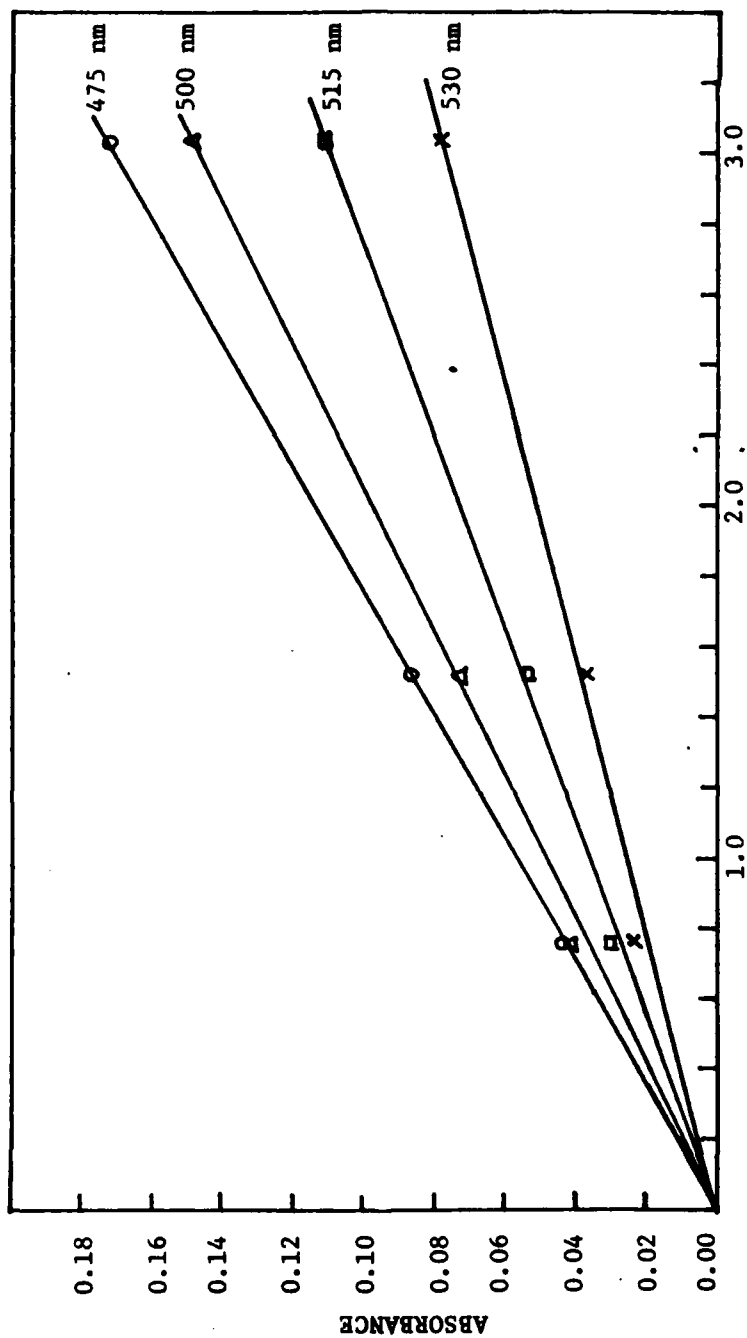

Figure 22. Beer's law plot for guanidine-reagent complex

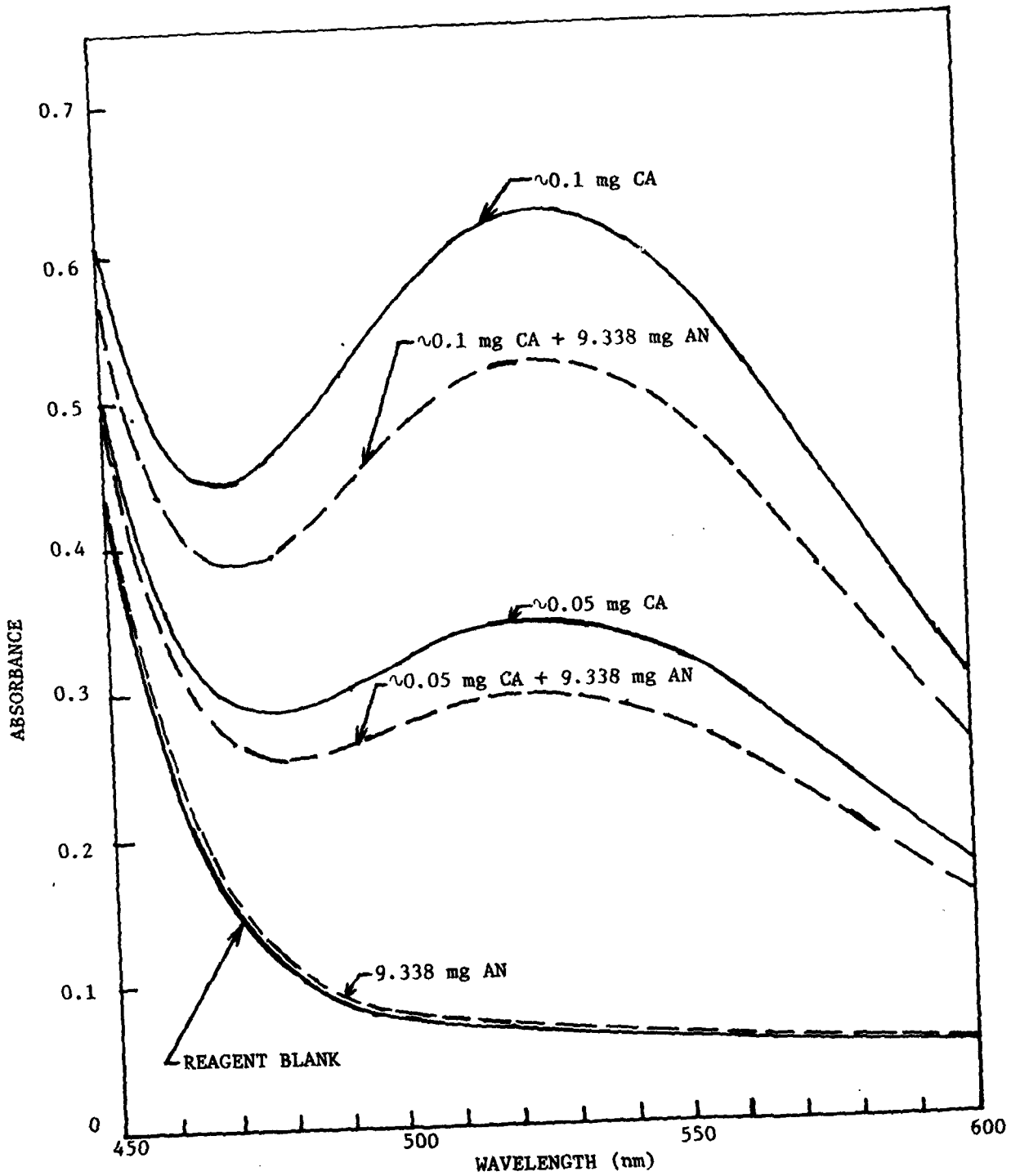

Figure 23. Effect of ammonium nitrate on cyanamide-reagent complex

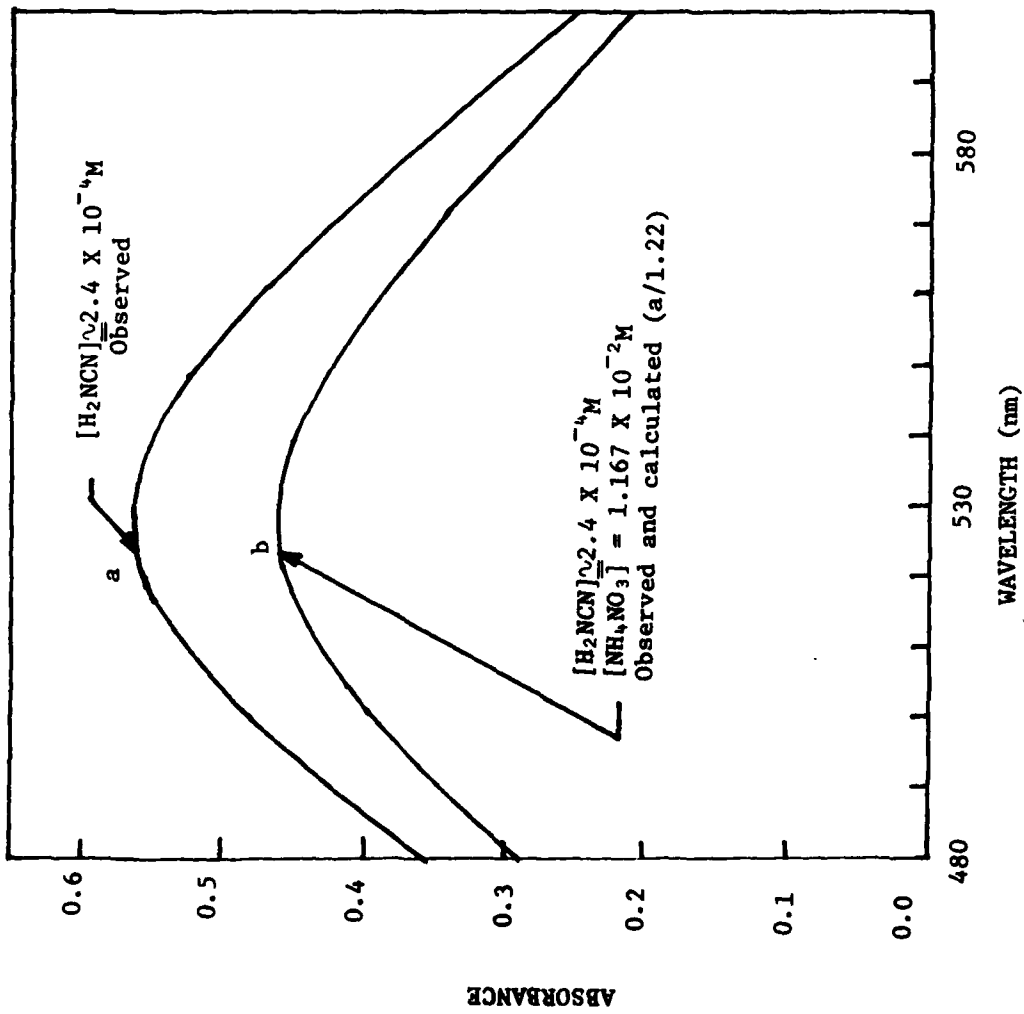

Figure 24. Effect of NH_4NO_3 on cyanamide-reagent complex

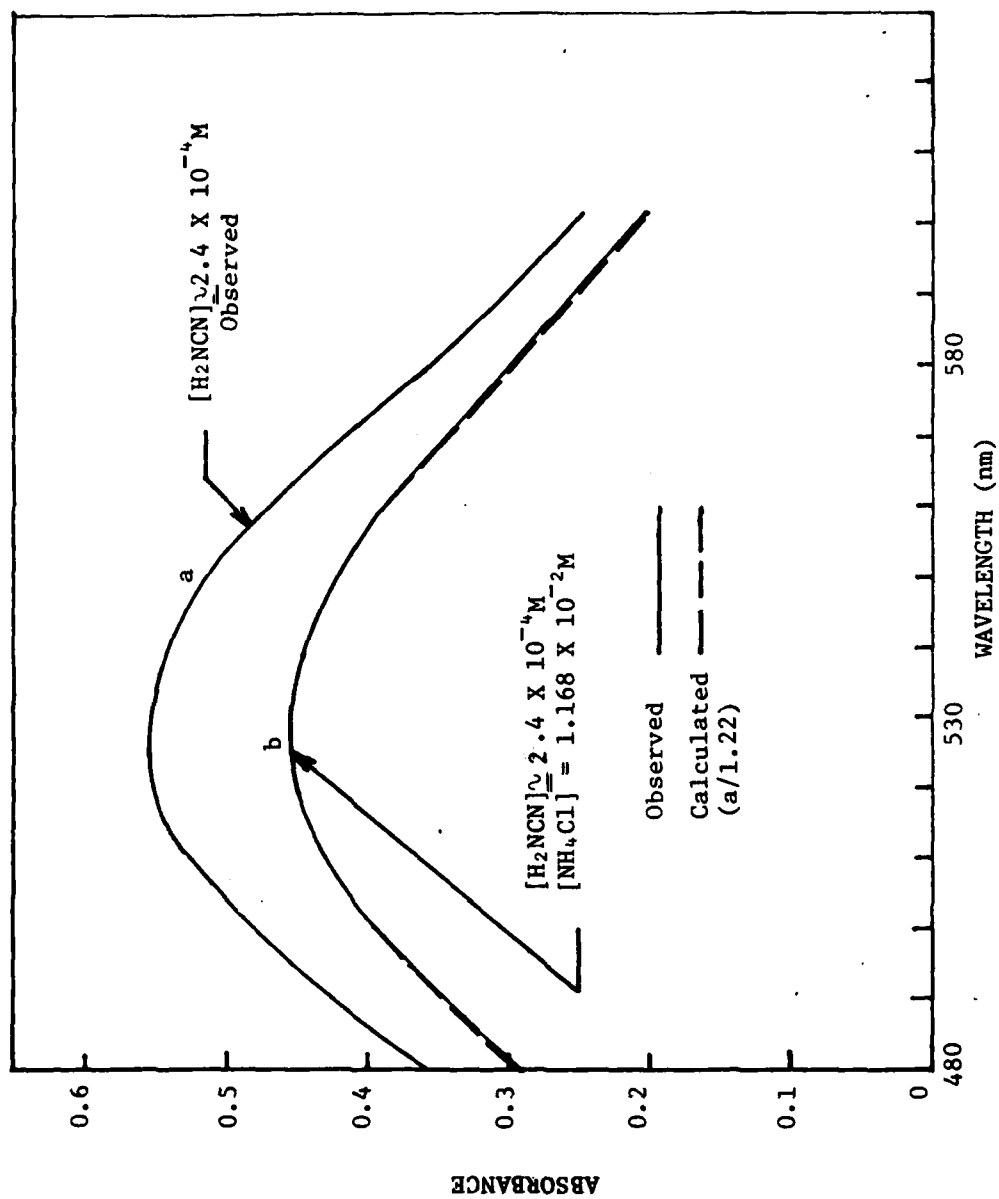

Figure 25. Effect of NH_4Cl on cyanamide-reagent complex

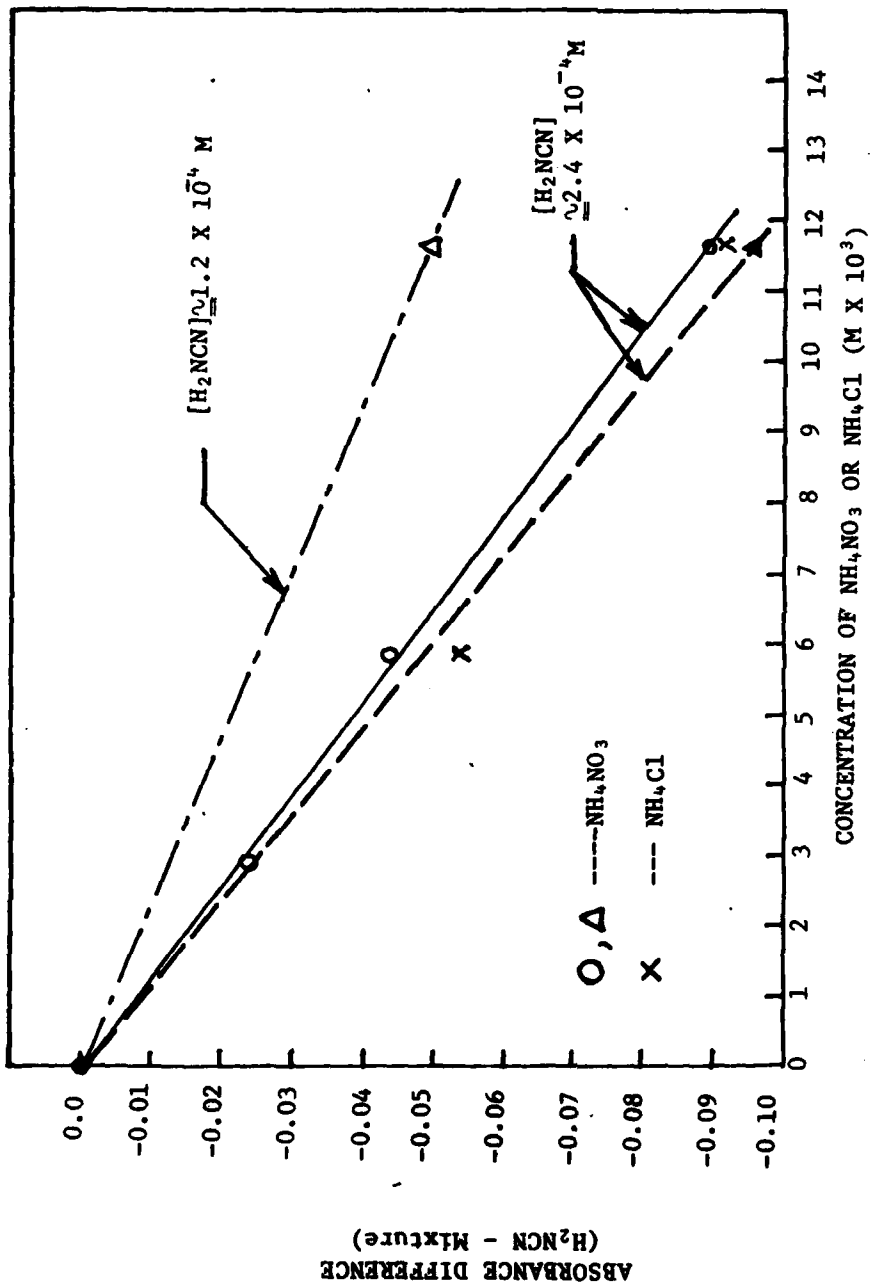

Figure 26. Effect of NH_4^+ on cyanamide-reagent complex

L,100,360

```
100= PROGRAM GNLR(OUTPUT,TAPE6=OUTPUT)
110= DIMENSION A(3),B(3),C(3),D(3),E(12)
120= CALL CONNOC(6,OUTPUT)
130= A(1)=.316
140= A(2)=.294
150= A(3)=.216
160= B(1)=.2333.
170= B(2)=2000.
180= B(3)=1346.
190= C(1)=-3.4E04
200= C(2)=-2.9E04
210= C(3)=-2.0E04
220= D(1)=25.7
230= D(2)=48.7
240= D(3)=56.7
250= E(1)=B(1)*C(2)*D(3)+C(1)*D(2)*B(3)+D(1)*C(3)*B(2)
260= E(2)=-D(1)*C(2)*B(3)-D(2)*C(3)*B(1)-D(3)*B(2)*C(1)
270= E(3)=E(1)+E(2)
280= E(4)=A(1)*C(2)*D(3)+C(1)*D(2)*A(3)+D(1)*C(3)*A(2)
290= E(5)=-D(1)*C(2)*A(3)-D(2)*C(3)*A(1)-D(3)*A(2)*C(1)
300= E(6)=E(4)+E(5)
310= E(7)=B(1)*A(2)*D(3)+A(1)*D(2)*B(3)+D(1)*A(3)*B(2)
320= E(8)=-D(1)*A(2)*B(3)-D(2)*A(3)*B(1)-D(3)*B(2)*A(1)
330= E(9)=E(7)+E(8)
340= E(10)=B(1)*C(2)*A(3)+C(1)*A(2)*B(3)+A(1)*C(3)*B(2)
350= E(11)=-A(1)*C(2)*B(3)-A(2)*C(3)*B(1)-A(3)*B(2)*C(1)
360= E(12)=E(10)+E(11)
```

Figure 27. CDC Fortran computer program for solving modified simultaneous linear equations

L.370,530

```
370- X=E(6)/E(3)
380- Y=E(9)/E(3)/X
390- Z=E(12)/E(3)
400- WRITE(6,1) CYANAMIDE(M)*X
410-1  FORMAT(6,2) X
420- WRITE(6,2) X
430-2  FORMAT(3X,E13.4)
440- WRITE(6,3) AMMONIUM ION(M)*X
450-3  FORMAT(6,4) Y
460- WRITE(6,4) Y
470-4  FORMAT(3X,E13.3)
480- WRITE(6,5)
490-5  FORMAT(6,6) Z
500- WRITE(6,6) Z
510-6  FORMAT(3X,E13.3)
520- STOP
530- END
..SAVE,PROG1
..RUN,FTN,FILE=PROG1
CYANAMIDE(M)
.1875E-03
AMMONIUM ION(M)
.225E-01
GUANIDINE NITRATE(M)
.843E-03
STOP
.679 CP SECONDS COMPILATION TIME
.016 CP SECONDS EXECUTION TIME
..
```

Figure 27. (cont)

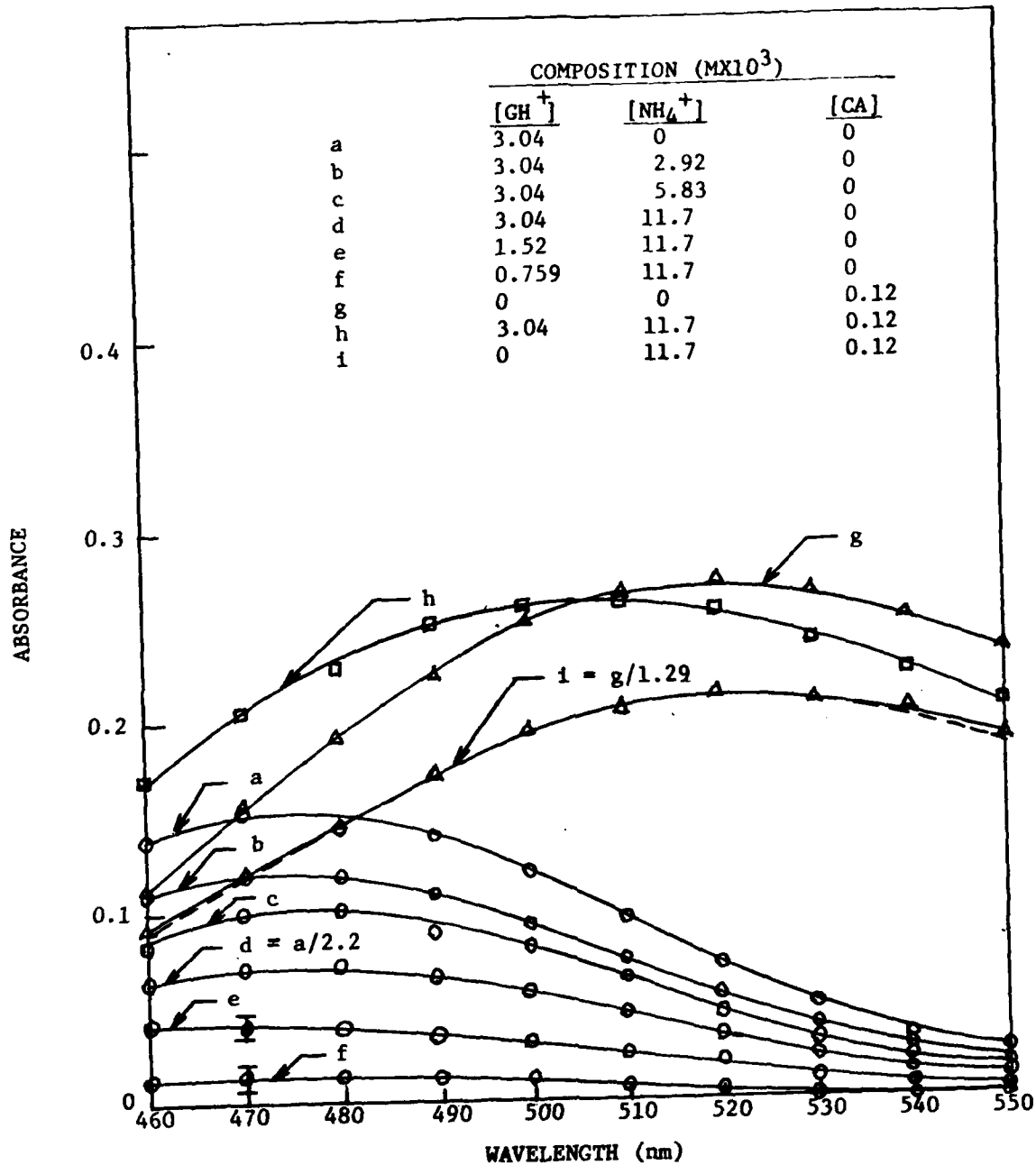

Figure 28. Effect of NH₄⁺ on cyanamide-reagent and guanidinium ion-reagent complexes

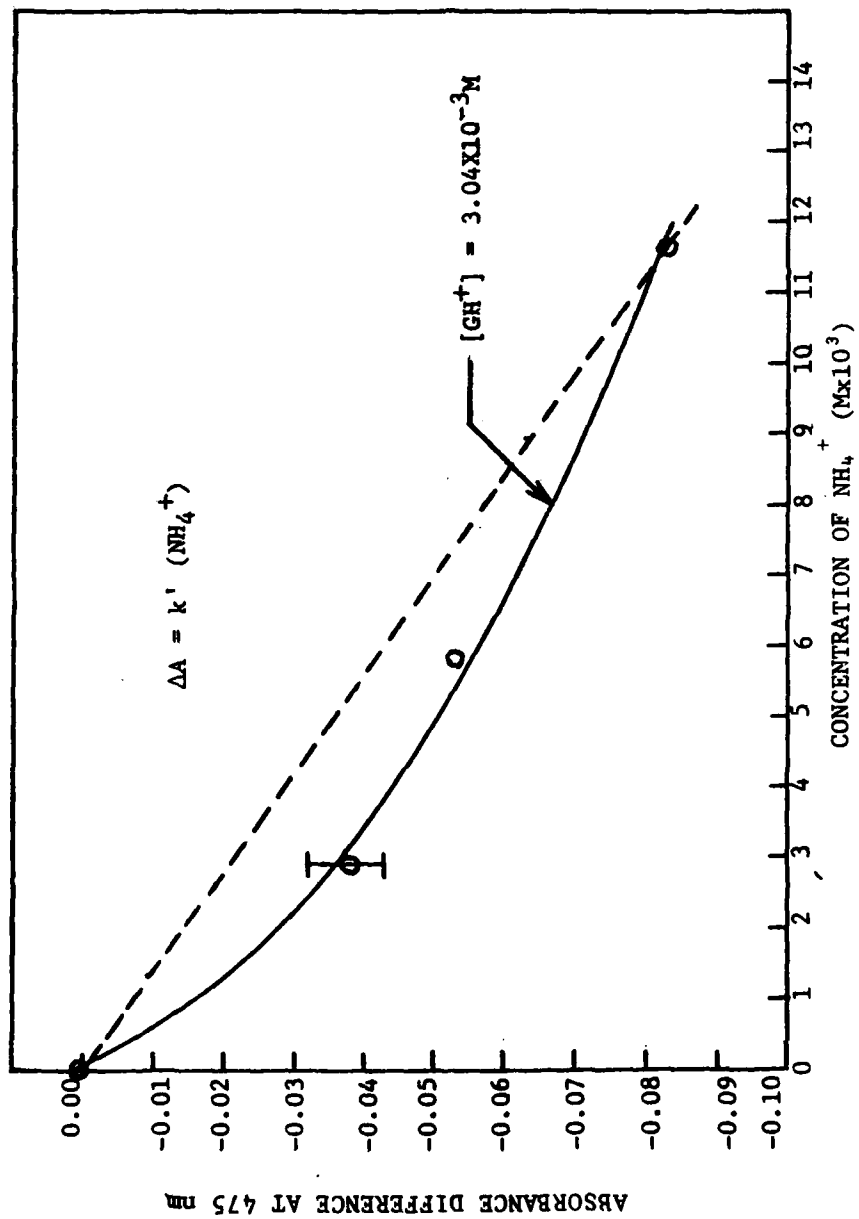

Figure 29. Effect of NH₄⁺ on guanidinium ion-reagent complex

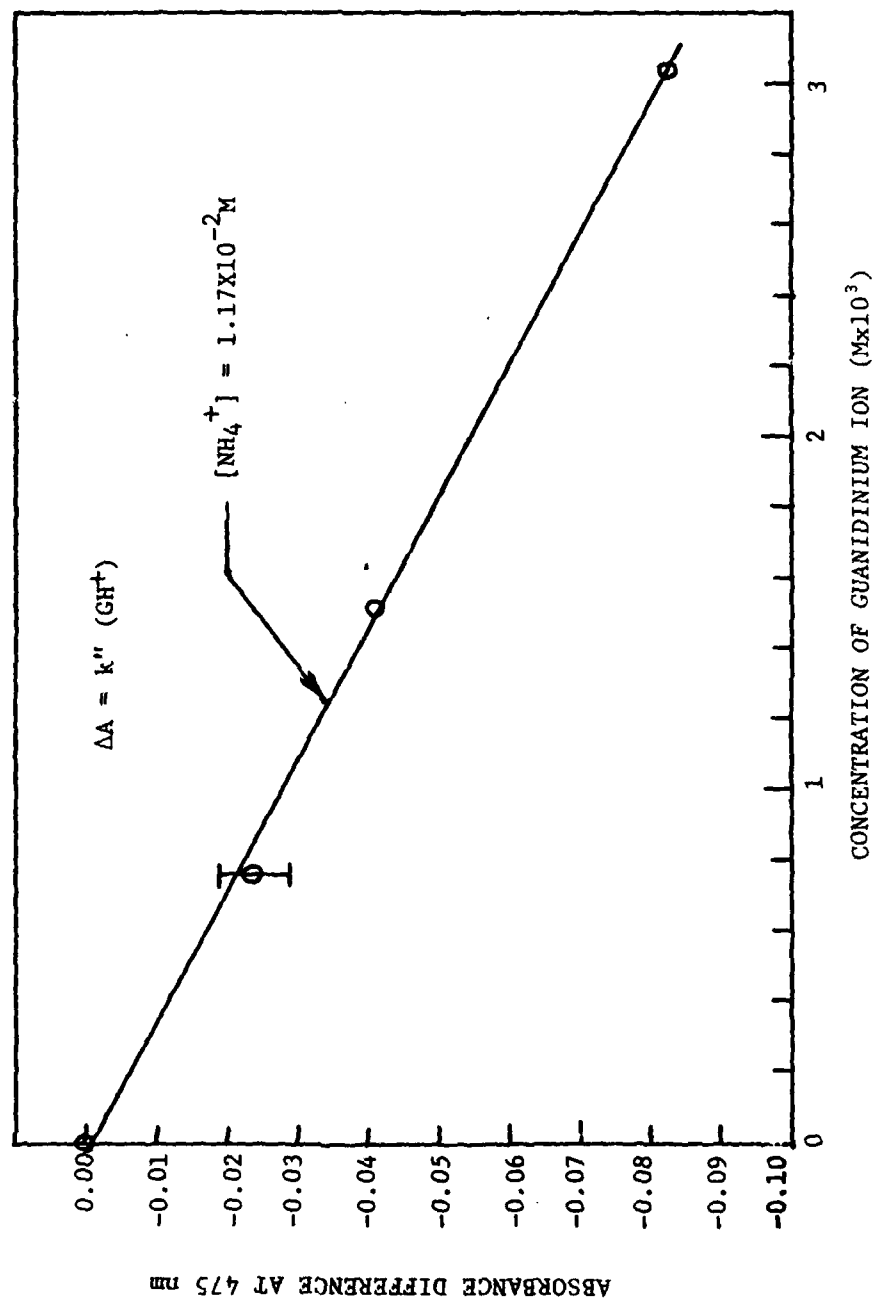

Figure 30. Effect of NH_4^+ on guanidinium ion-reagent complex

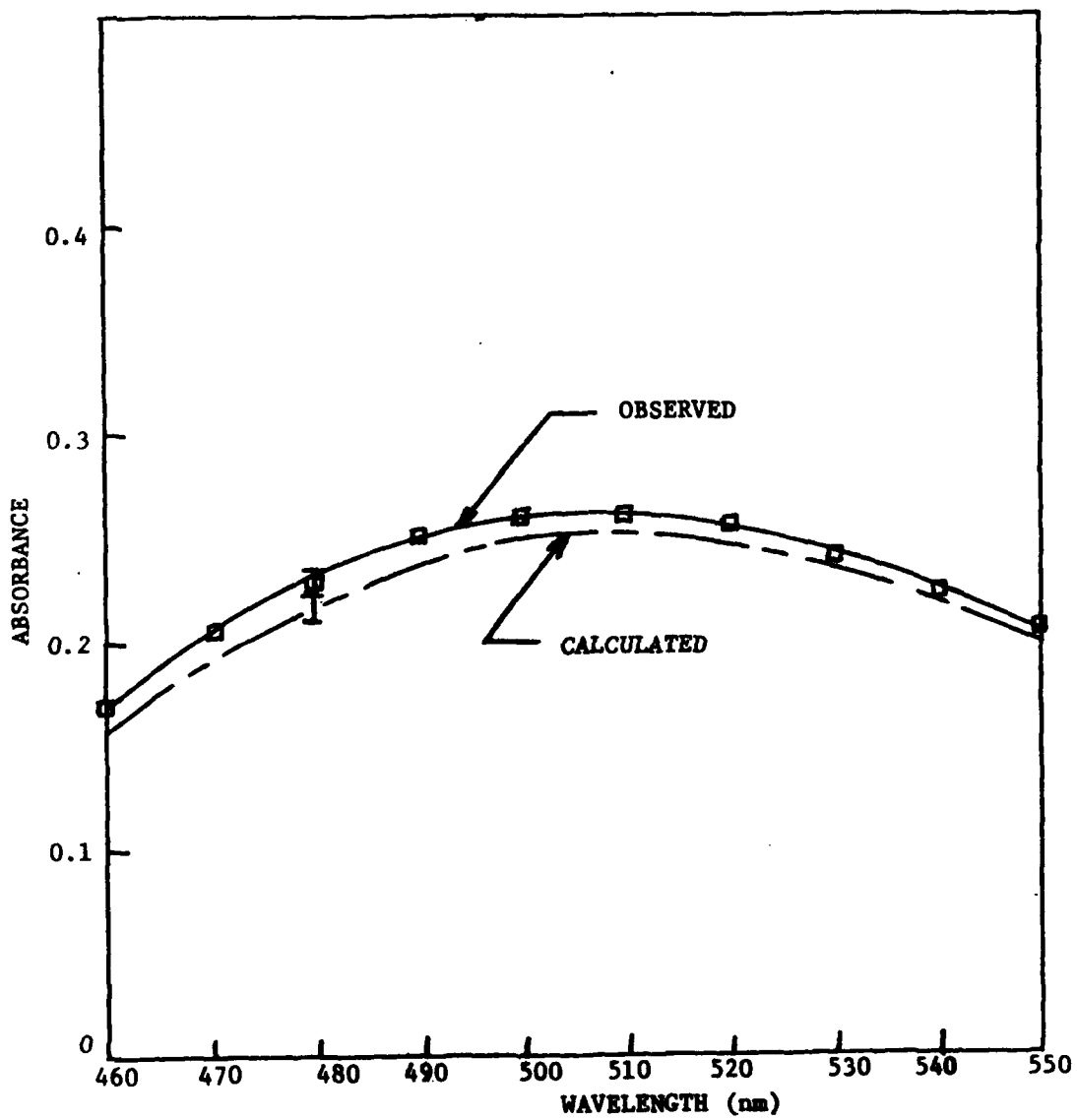

Figure 31. Effect of NH_4^+ on cyanamide-reagent and guanidinium ion-reagent complexes

DISTRIBUTION LIST

Commander
U.S. Army Armament Materiel
Readiness Command
ATTN: DRSAR-LEP-L
 DRSAR-OP
 DRSAR-QA
 DRSAR-SF
 DRSAR-IRC
Rock Island, IL 61299

Director
Ballistics Research Laboratory
U.S. Army Armament Research and
Development Command
ATTN: DRDAR-TSB-S
Aberdeen Proving Ground, MD 21005

Commander/Director
Chemical Systems Laboratory
U.S. Army Armament Research and
Development Command
ATTN: DRDAR-CLJ-L
 DRDAR-CLB-PA
APG, Edgewood Area, MD 21010

Chief
Benet Weapons Laboratory, LCWSL
U.S. Army Armament Research and
Development Command
ATTN: DRDAR-LCB-TL
Watervliet, NY 12189

Director
U.S. Army Materiel Systems
Analysis Activity
ATTN: DRXSY-MP
Aberdeen Proving Ground, MD 21005

Administrator
Defense Technical Information Center
ATTN: Accessions Division (12)
Cameron Station
Alexandria, VA 22314

Commander
U.S. Army Armament Research and
Development Command

ATTN: DRDAR-LC
DRDAR-LCE (3)
DRDAR-LCE-C (12)
DRDAR-LCM
DRDAR-LCS
DRDAR-TSE-I
DRDAR-QAR-R
DRDAR-SF
DRDAR-TSS (5)
DRDAR-GCL
Dover, NJ 07801

Sunflower Army Ammunition Plant
P.O. Box 640
ATTN: SARSU-O (10)
DeSoto, KS 66018

Commander
U.S. Army Munitions Production Base
Modernization Agency
ATTN: SARPM-PBM-EE, Mr. T. Caggiano
Dover, NJ 07801

Commander
U.S. Army Materiel Development and
Readiness Command
ATTN: DRCQA
DRCMT
DRCPP-PI
DRDCE-R
5001 Eisenhower Avenue
Alexandria, VA 22304

Division Engineer
U.S. Army Engineer Division,
Huntsville
ATTN: HNDED-PM
P.O. Box 1600, West Station
Huntsville, AL 35807

Division Engineer
U.S. Army Engineer Division, Missouri River
ATTN: MRDED-TG
P.O. Box 103, Downtown Station
Omaha, NE 68101

District Engineer
U.S. Army Engineer District, Kansas City
ATTN: MRKED-MI
601 E. 12th Street
Kansas City, MO 64106

Commander
U.S. Army Industrial Base
Engineering Activity
ATTN: DRXIB-MT
DRXIB-EN
Rock Island, IL 61299

Director
U.S. Army Materials and Mechanics
Research Center
ATTN: DRXMR-FR, Technical Information Section
Watertown MA 02171

Commander
Radford Army Ammunition Plant
ATTN: SARRA-EN (6)
Radford, VA 24141

Commander
Badger Army Ammunition Plant
Baraboo, WI 53913

Commander
Indiana Army Ammunition Plant
Charlestown, IN 47111

Commander
Holston Army Ammunition Plant
Texarkana, TX 37660

Commander
Louisiana Army Ammunition Plant
Shreveport, LA 71130

Commander
U.S. Naval Ordnance Station
Indianhead, MD 20640

Commander
Naval Weapons Center
China Lake, CA 93555

