

AFFDL-TR-79-3086

AD-A099639

DETERMINATION OF MOISTURE CONTENT
IN COMPOSITES
BY DIELECTRIC MEASUREMENTS

LOCKHEED-GEORGIA COMPANY
A Division of Lockheed Corporation
Marietta, Georgia 30063

July 1979

TECHNICAL REPORT AFFDL-TR-79-3086
Final Report for Period June 1978 - June 1979

Approved for public release; distribution unlimited.

Prepared for:

AIR FORCE FLIGHT DYNAMICS LABORATORY
AIR FORCE WRIGHT AERONAUTICAL LABORATORIES
AIR FORCE SYSTEMS COMMAND
WRIGHT-PATTERSON AIR FORCE BASE, OHIO 45433

20070925186

NOTICE

When Government drawings, specifications, or other data are used for any purpose other than in connection with a definitely related Government procurement operation, the United States Government thereby incurs no responsibility nor any obligation whatsoever; and the fact that the government may have formulated, furnished, or in any way supplied the said drawings, specifications, or other data, is not to be regarded by implication or otherwise as in any manner licensing the holder or any other person or corporation, or conveying any rights or permission to manufacture use, or sell any patented invention that may in any way be related thereto.

This report has been reviewed by the Office of Public Affairs (ASD/PA) and is releasable to the National Technical Information Service (NTIS). At NTIS, it will be available to the general public, including foreign nations.

This technical report has been reviewed and is approved for publication.

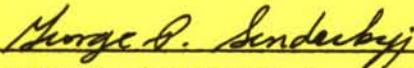

GEORGE P. SENDECKYJ, Aero. Engr.
Fatigue, Fracture & Reliability Gp.
Structural Integrity Branch
Structures & Dynamics Division

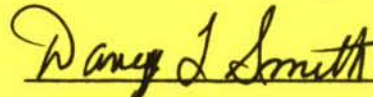

DAVEY L. SMITH, Chief
Structural Integrity Branch
Structures & Dynamics Division

FOR THE COMMANDER

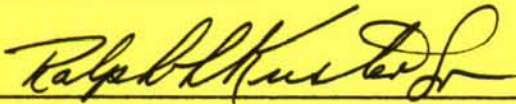

RALPH L. KUSTER, Chief
Structures & Dynamics Division

"If your address has changed, if you wish to be removed from our mailing list, or if the addressee is no longer employed by your organization please notify AFWAL/FIBE, W-PAFB, OH 45433 to help us maintain a current mailing list".

Copies of this report should not be returned unless return is required by security considerations, contractual obligations, or notice on a specific document.

REPORT DOCUMENTATION PAGE		READ INSTRUCTIONS BEFORE COMPLETING FORM	
1. REPORT NUMBER AFFDL-TR-79-3086	2. GOVT ACCESSION NO.	3. RECIPIENT'S CATALOG NUMBER	
4. TITLE (and Subtitle) DETERMINATION OF MOISTURE CONTENT IN COMPOSITES BY DIELECTRIC MEASUREMENTS		5. TYPE OF REPORT & PERIOD COVERED Final June 1978 - June 1979	
		6. PERFORMING ORG. REPORT NUMBER LG79ER0091	
7. AUTHOR(s) A. O. Kays		8. CONTRACT OR GRANT NUMBER(s) F33615-78-C-3216	
9. PERFORMING ORGANIZATION NAME AND ADDRESS Lockheed-Georgia Company Marietta, GA 30063		10. PROGRAM ELEMENT, PROJECT, TASK AREA & WORK UNIT NUMBERS Program Element 62201F Project 2401/01/29	
11. CONTROLLING OFFICE NAME AND ADDRESS Structures and Dynamics Division (FBE) Air Force Flight Dynamics Laboratory Wright-Patterson AFB, OH 45433		12. REPORT DATE July 1979	
		13. NUMBER OF PAGES 172	
14. MONITORING AGENCY NAME & ADDRESS (if different from Controlling Office)		15. SECURITY CLASS. (of this report) UNCLASSIFIED	
		15a. DECLASSIFICATION/DOWNGRADING SCHEDULE	
16. DISTRIBUTION STATEMENT (of this Report) Approved for public release; distribution unlimited.			
17. DISTRIBUTION STATEMENT (of the abstract entered in Block 20, if different from Report) N/A			
18. SUPPLEMENTARY NOTES N/A			
19. KEY WORDS (Continue on reverse side if necessary and identify by block number) Composites Environmental Exposure Capacitance Moisture Content Dielectric Moisture Distribution Embedded Sensors			
20. ABSTRACT (Continue on reverse side if necessary and identify by block number) This program has been conducted in two tasks. In Task I, three-ply graphite/epoxy laminates with sensors embedded at their midplanes were exposed to various hygrothermal environments. Moisture content versus time was determined by weight measurements at discrete times during each exposure condition. In addition, capacitance readings were measured by the sensors at those same times. The capacitance was then converted to percent change at each time period and compared with the laminate moisture content. From			

20. ABSTRACT (continued)

the measured weight gain data, an analytical least squares curve fit program was used to establish the moisture diffusion coefficients necessary to then analytically establish the moisture content at the laminate midplane at the discrete weight and capacitance measurement times. This procedure established a relationship between capacitance and local moisture content. A similar procedure was used in Task II where the graphite/epoxy laminates were thirteen plies thick and six sensors were placed through the thickness. The local moisture content/capacitance relationship with these Task II specimens were evaluated and compared with the results obtained in Task I.

FOREWORD

The developments reported herein were accomplished under the sponsorship of the Air Force Flight Dynamics Laboratory, Structural Integrity Branch, Wright-Patterson Air Force Base, Ohio 45433. Dr. G. P. Sendecky was the Air Force Project Monitor.

The development activities reported herein were performed under the direction of the Advanced Structures Department, Lockheed-Georgia Company, with Mr. A. O. Kays as Program Manager. Other Lockheed-Georgia Company personnel associated with the program and their respective areas of responsibility include:

- R. L. Caruthers, Data Correlation
- S. M. Freeman, Specimen Fabrication
- L. Green, Jr., Dielectric and Weight Measurements
- H. R. Ingle, Jr., Electronics and Sensor Development--Formerly with Lockheed-Georgia Company
- B. E. Pickett, Analytical Moisture Model
- E. V. Vasciannie, Data Correlation

This report is also identified by LG79ER0091 for Lockheed internal control purposes.

TABLE OF CONTENTS

<u>Section</u>	<u>Title</u>	<u>Page</u>
1.0	INTRODUCTION	1
2.0	TECHNICAL DISCUSSION	3
2.1	EXPERIMENTAL TEST PROGRAM	3
2.1.1	Materials and Equipment	3
2.1.1.1	Laminate Material	3
2.1.1.2	Capacitance Sensor and Meter	3
2.1.1.3	Environmental Test Equipment	5
2.1.1.4	Analytical Balance and Support Fixture	6
2.1.2	Specimen and Sensor Configuration and Fabrication	6
2.1.2.1	Sensor Configuration and Fabrication	6
2.1.2.2	Specimen Configuration and Fabrication	13
2.1.3	Environmental Testing and Procedures	18
2.1.3.1	Temperature/Humidity Environmental Testing	18
2.1.3.2	Weighing and Capacitance Measure- ment Procedure	19
2.1.4	Analytical Moisture Model	21
2.2	DISCUSSION OF TEST RESULTS	24
2.2.1	Task I Test Results	24
2.2.1.1	3-Ply Specimens Exposed to 120°F/ 98% RH Absorb and 120°F/0% RH Desorb	24
2.2.1.2	3-Ply Specimens Exposed to 120°F/ 50% RH Absorb and 120°F/0% RH Desorb	29
2.2.1.3	3-Ply Specimens Exposed to RT/50% RH Absorb and RT/0% RH Desorb	34
2.2.1.4	3-Ply Specimens Exposed to 160°F/ 75% RH Absorb and 160°F/20% RH Desorb	34

TABLE OF CONTENTS (Continued)

<u>Section</u>	<u>Title</u>	<u>Page</u>
2.2.1.5	3-Ply Specimens Exposed to 160°F/ 98% RH Absorb and 160°F/0% RH Desorb	39
2.2.1.6	3-Ply Specimens Exposed to 160°F/ 98% RH Absorb and 160°F/50% RH Desorb	44
2.2.1.7	3-Ply Specimens Exposed to 160°F/ 50% RH Absorb and 160°F/0% RH Desorb	44
2.2.1.8	3-Ply Specimens Exposed to RT/ 93% RH Absorb and RT/0% RH Desorb	49
2.2.1.9	3-Ply Specimens Exposed to RT/ 75% RH Absorb and RT/0% RH Desorb	49
2.2.1.10	3-Ply Specimens Exposed to 120°F/ 75% RH Absorb and 120°F/0% RH Desorb	53
2.2.1.11	Moisture Content/Capacitance Correlation for Task I Specimens	57
2.2.2	Task II Test Results	57
2.3	CONCLUSIONS AND RECOMMENDATIONS	83
2.3.1	Conclusions	83
2.3.2	Recommendations	84
	REFERENCES	87
	APPENDIX	89

LIST OF FIGURES

<u>Figure</u>	<u>Title</u>	<u>Page</u>
1	Capacitance Sensor Detail	4
2	Portable Capacitance Meter	5
3	Environmental Test Equipment	7
4	Desorption Chamber and Temperature Readout	7
5	Sensor Fabrication Fixture	8
6	Early Sensor/Specimen Configuration	9
7	Early Specimen and Sensor Installation	10
8	Final Design for Environmental Exposure Specimen and Sensor	11
9	Sensor Loop and Lead Wire Detail	12
10	Cross Section of the Sensor Final Design	12
11	Sensor Installation in Early 3-Ply Specimens	15
12	Four Sensor Installations in 13-Ply Laminate A	15
13	Two Sensor Installations in 13-Ply Laminate A	16
14	Typical Sensor Installations for Specimen C	16
15	Close-up of a Typical Sensor Installation of Specimen A	17
16	Close-up of a Typical Sensor Installation of Specimen C	17
17	Average M_c versus $\% \Delta C$ for Specimens 3B and 6B	25
18	Local M_c versus $\% \Delta C$ for Specimens 3B and 6B	26
19	Average M_c versus $\% \Delta C$ for Specimens 1B, 2A, and 14A	27
20	Local M_c versus $\% \Delta C$ for Specimens 1B, 2A, and 14A	28
21	Cross Section Through Sleeve Area of Specimen 1B	30
22	Cross Section Through Sleeve Area of Specimen 2A	30
23	Cross Section Through Sleeve Area of Specimen 14A	31
24	Average M_c versus $\% \Delta C$ for Specimens 3A and 8B	32
25	Local M_c versus $\% \Delta C$ for Specimens 3A and 8B	33
26	Average M_c versus $\% \Delta C$ for Specimens 4B, 8A, and 8B	35
27	Local M_c versus $\% \Delta C$ for Specimen 4B	36
28	Local M_c versus $\% \Delta C$ for Specimens 8A and 8B	37
29	Average M_c versus $\% \Delta C$ for Specimens 13, 17, and 21	38

LIST OF FIGURES (Continued)

<u>Figure</u>	<u>Title</u>	<u>Page</u>
30	Local M_c versus $\% \Delta C$ for Specimens 13 and 17	40
31	Local M_c versus $\% \Delta C$ for Specimen 21	41
32	Average M_c versus $\% \Delta C$ for Specimens 29 and 31	42
33	Local M_c versus $\% \Delta C$ for Specimens 29 and 31	43
34	Average M_c versus $\% \Delta C$ for Specimens 32 and 33	45
35	Local M_c versus $\% \Delta C$ for Specimens 32 and 33	46
36	Average M_c versus $\% \Delta C$ for Specimens 30 and 35	47
37	Local M_c versus $\% \Delta C$ for Specimens 30 and 35	48
38	X-Ray Photograph of Type IV Specimens	50
39	Average M_c versus $\% \Delta C$ for Specimens AFD, BFD, and CFD	51
40	Local M_c versus $\% \Delta C$ for Specimen AFD	52
41	Average M_c versus $\% \Delta C$ for Specimens DFD, EFD, and FFD	54
42	Local M_c versus $\% \Delta C$ for Specimen DFD	55
43	Average M_c versus $\% \Delta C$ for Specimens GFD, HFD, and IFD	56
44	Local M_c versus $\% \Delta C$ for Specimen GFD	58
45	Moisture Content/Capacitance Correlation for Specimen AFD	59
46	Moisture Content/Capacitance Correlation for Specimen BFD	60
47	Moisture Content/Capacitance Correlation for Specimen CFD	61
48	Moisture Content/Capacitance Correlation for Specimen DFD	62
49	Moisture Content/Capacitance Correlation for Specimen EFD	63
50	Moisture Content/Capacitance Correlation for Specimen FFD	64
51	Moisture Content/Capacitance Correlation for Specimen GFD	65
52	Moisture Content/Capacitance Correlation for Specimen HFD	66
53	Moisture Content/Capacitance Correlation for Specimen IFD	67
54	X-Ray Photograph Showing Sensor Installation for Specimens A and B	68
55	X-Ray Photograph Showing Sensor Installation for Specimens C and D	68
56	Δ Capacitance Versus Moisture Content for 13-Ply Specimen A	70
57	Δ Capacitance Versus Moisture Content for 13-Ply Specimen B	71
58	Δ Capacitance Versus Moisture Content for 13-Ply Specimen C	72

LIST OF FIGURES (Continued)

<u>Figure</u>	<u>Title</u>	<u>Page</u>
59	Δ Capacitance Versus Moisture Content for 13-Ply Specimen D	73
60	Local M_c vs % Δ C for Sensor #3 of Specimen A	74
61	Local M_c vs % Δ C for Sensor #4 of Specimen A	75
62	Local M_c vs % Δ C for Sensor #2 of Specimen A	76
63	Local M_c vs % Δ C for Sensor #5 of Specimen A	77
64	Local M_c vs % Δ C for Sensors #1 and #6 for Specimen A	78
65	Local M_c vs % Δ C for Sensors #3 and #4 of Specimen C	79
66	Local M_c vs % Δ C for Sensors #2 and #5 of Specimen C	80
67	Local M_c vs % Δ C for Sensors #1 and #6 of Specimen C	81
A-1	Average Moisture Content vs $\sqrt{\text{Time}}$ for 3-Ply Specimens Exposed to RT/50/0	147
A-2	Local Moisture Content vs $\sqrt{\text{Time}}$ for 3-Ply Specimens Exposed to RT/50/0	148
A-3	Average Moisture Content vs $\sqrt{\text{Time}}$ for 3-Ply Specimens Exposed to RT/75/0	149
A-4	Local Moisture Content vs $\sqrt{\text{Time}}$ for 3-Ply Specimens Exposed to RT/75/0	150
A-5	Average Moisture Content vs $\sqrt{\text{Time}}$ for 3-Ply Specimens Exposed to RT/93/0	151
A-6	Local Moisture Content vs $\sqrt{\text{Time}}$ for 3-Ply Specimens Exposed to RT/93/0	152
A-7	Average Moisture Content vs $\sqrt{\text{Time}}$ for 3-Ply Specimens Exposed to 120/50/0	153
A-8	Local Moisture Content vs $\sqrt{\text{Time}}$ for 3-Ply Specimens Exposed to 120/50/0	154
A-9	Average Moisture Content vs $\sqrt{\text{Time}}$ for 3-Ply Specimens Exposed to 120/75/0	155
A-10	Local Moisture Content vs $\sqrt{\text{Time}}$ for 3-Ply Specimens Exposed to 120/75/0	156
A-11	Average Moisture Content vs $\sqrt{\text{Time}}$ for 3-Ply Specimens Exposed to 120/98/0	157
A-12	Local Moisture Content vs $\sqrt{\text{Time}}$ for 3-Ply Specimens Exposed to 120/98/0	158

LIST OF FIGURES (Continued)

<u>Figure</u>	<u>Title</u>	<u>Page</u>
A-13	Average Moisture Content vs $\sqrt{\text{Time}}$ for 3-Ply Specimens Exposed to 160/50/0	159
A-14	Local Moisture Content vs $\sqrt{\text{Time}}$ for 3-Ply Specimens Exposed to 160/50/0	160
A-15	Average Moisture Content vs $\sqrt{\text{Time}}$ for 3-Ply Specimens Exposed to 160/75/0	161
A-16	Local Moisture Content vs $\sqrt{\text{Time}}$ for 3-Ply Specimens Exposed to 160/75/0	162
A-17	Average Moisture Content vs $\sqrt{\text{Time}}$ for 3-Ply Specimens Exposed to 160/98/0	163
A-18	Local Moisture Content vs $\sqrt{\text{Time}}$ for 3-Ply Specimens Exposed to 160/98/0	164
A-19	Average Moisture Content vs $\sqrt{\text{Time}}$ for 3-Ply Specimens Exposed to 160/98/50	165
A-20	Local Moisture Content vs $\sqrt{\text{Time}}$ for 3-Ply Specimens Exposed to 160/98/50	166
A-21	Average Moisture Content vs $\sqrt{\text{Time}}$ for 13-Ply Specimens Exposed to 160/98/0	167
A-22	Local Moisture Content at Specimen Center vs $\sqrt{\text{Time}}$ for 13-Ply Specimens Exposed to 160/98/0	168
A-23	Local Moisture Content at 0.0055 Inch from Specimen Center vs $\sqrt{\text{Time}}$ for 13-Ply Specimens Exposed to 160/98/0	169
A-24	Local Moisture Content at 0.0110 Inch from Specimen Center vs $\sqrt{\text{Time}}$ for 13-Ply Specimens Exposed to 160/98/0	170
A-25	Local Moisture Content at 0.0165 Inch from Specimen Center vs $\sqrt{\text{Time}}$ for 13-Ply Specimens Exposed to 160/98/0	171
A-26	Local Moisture Content at 0.0275 Inch from Specimen Center vs $\sqrt{\text{Time}}$ for 13-Ply Specimens Exposed to 160/98/0	172

LIST OF TABLES

<u>Table</u>	<u>Title</u>	<u>Page</u>
1	Environmental Conditions	18
2	Environmental Test Sequence	19
A-1	Cycle No. 1 Exposure to 120°F/98% RH Absorb and 120°F/0% RH Desorb for Specimen 3B	90
A-2	Cycle No. 2 Exposure to 120°F/98% RH Absorb and 120°F/0% RH Desorb for Specimen 3B	91
A-3	Cycle No. 1 Exposure to 120°F/98% RH Absorb and 120°F/0% RH Desorb for Specimen 6B	92
A-4	Cycle No. 2 Exposure to 120°F/98% RH Absorb and 120°F/0% RH Desorb for Specimen 6B	93
A-5	Cycle No. 1 Exposure to 120°F/98% RH Absorb and 120°F/0% RH Desorb for Specimen 1B	94
A-6	Cycle No. 2 Exposure to 120°F/98% RH Absorb and 120°F/0% RH Desorb for Specimen 1B	95
A-7	Cycle No. 1 Exposure to 120°F/98% RH Absorb and 120°F/0% RH Desorb for Specimen 2A	96
A-8	Cycle No. 2 Exposure to 120°F/98% RH Absorb and 120°F/0% RH Desorb for Specimen 2A	97
A-9	Cycle No. 1 Exposure to 120°F/98% RH Absorb and 120°F/0% RH Desorb for Specimen 14A	98
A-10	Cycle No. 2 Exposure to 120°F/98% RH Absorb and 120°F/0% RH Desorb for Specimen 14A	99
A-11	Initial Absorb Cycle for Specimen 3A Exposed to 120°F/50% RH Absorb and 120°F/0% RH Desorb	100
A-12	Cycle No. 1 Exposure to 120°F/50% RH Absorb and 120°F/0% RH Desorb for Specimen 3A	101
A-13	Cycle No. 2 Exposure to 120°F/50% RH Absorb and 120°F/0% RH Desorb for Specimen 3A	102
A-14	Initial Absorb Cycle for Specimen 8B Exposed to 120°F/50% RH Absorb and 120°F/0% RH Desorb	103
A-15	Cycle No. 1 Exposure to 120°F/50% RH Absorb and 120°F/0% RH Desorb for Specimen 8B	104
A-16	Cycle No. 2 Exposure to 120°F/50% RH Absorb and 120°F/0% RH Desorb for Specimen 8B	105

LIST OF TABLES (Continued)

<u>Table</u>	<u>Title</u>	<u>Page</u>
A-17	Initial Absorb Cycle for Specimen 15B Exposed to 120°F/50% RH Absorb and 120°F/0% RH Desorb	106
A-18	Cycle No. 1 Exposure to 120°F/50% RH Absorb and 120°F/0% RH Desorb for Specimen 15B	107
A-19	Cycle No. 1 Exposure to RT/50% RH Absorb and RT/0% RH Desorb for Specimen 4B	108
A-20	Cycle No. 1 Exposure to RT/50% RH Absorb and RT/0% RH Desorb for Specimen 8A	109
A-21	Cycle No. 1 Exposure to RT/50% RH Absorb and RT/0% RH Desorb for Specimen 8B	110
A-22	Cycle No. 1 Exposure to 160°F/75% RH Absorb and 160°F/20% RH Desorb for Specimen 13	111
A-23	Cycle No. 2 Exposure to 160°F/75% RH Absorb and 160°F/20% RH Desorb for Specimen 13	112
A-24	Cycle No. 1 Exposure to 160°F/75% RH Absorb and 160°F/20% RH Desorb for Specimen 17	113
A-25	Cycle No. 2 Exposure to 160°F/75% RH Absorb and 160°F/20% RH Desorb for Specimen 17	114
A-26	Cycle No. 1 Exposure to 160°F/75% RH Absorb and 160°F/20% RH Desorb for Specimen 21	115
A-27	Cycle No. 2 Exposure to 160°F/75% RH Absorb and 160°F/20% RH Desorb for Specimen 21	116
A-28	Cycle No. 1 Exposure to 160°F/98% RH Absorb and 160°F/0% RH Desorb for Specimen 29	117
A-29	Cycle No. 2 Exposure to 160°F/98% RH Absorb and 160°F/0% RH Desorb for Specimen 29	118
A-30	Cycle No. 1 Exposure to 160°F/98% RH Absorb and 160°F/0% RH Desorb for Specimen 31	119
A-31	Cycle No. 2 Exposure to 160°F/98% RH Absorb and 160°F/0% RH Desorb for Specimen 31	120
A-32	Cycle No. 1 Exposure to 160°F/98% RH Absorb and 160°F/50% RH Desorb for Specimen 32	121
A-33	Cycle No. 1 Exposure to 160°F/98% RH Absorb and 160°F/50% RH Desorb for Specimen 33	122

LIST OF TABLES (Continued)

<u>Table</u>	<u>Title</u>	<u>Page</u>
A-34	Cycle No. 1 Exposure to 160°F/50% RH Absorb and 160°F/0% RH Desorb for Specimen 30	123
A-35	Cycle No. 1 Exposure to 160°F/50% RH Absorb and 160°F/0% RH Desorb for Specimen 35	124
A-36	Cycle No. 1 Exposure to RT/93% RH Absorb and RT/0% RH Desorb for Specimen AFD	125
A-37	Cycle No. 2 Exposure to RT/93% RH Absorb and RT/0% RH Desorb for Specimen AFD	126
A-38	Cycle No. 1 Exposure to RT/93% RH Absorb and RT/0% RH Desorb for Specimen BFD	127
A-39	Cycle No. 2 Exposure to RT/93% RH Absorb and RT/0% RH Desorb for Specimen BFD	128
A-40	Cycle No. 1 Exposure to RT/93% RH Absorb and RT/0% RH Desorb for Specimen CFD	129
A-41	Cycle No. 2 Exposure to RT/93T RH Absorb and RT/0% RH Desorb for Specimen CFD	130
A-42	Cycle No. 1 Exposure to RT/75% RH Absorb and RT/0% RH Desorb for Specimen DFD	131
A-43	Cycle No. 2 Exposure to RT/75% RH Absorb and RT/0% RH Desorb for Specimen DFD	132
A-44	Cycle No. 1 Exposure to RT/75% RH Absorb and RT/0% RH Desorb for Specimen EFD	133
A-45	Cycle No. 2 Exposure to RT/75% RH Absorb and RT/0% RH Desorb for Specimen EFD	134
A-46	Cycle No. 1 Exposure to RT/75% RH Absorb and RT/0% RH Desorb for Specimen FFD	135
A-47	Cycle No. 2 Exposure to RT/75% RH Absorb and RT/0% RH Desorb for Specimen FFD	136
A-48	Cycle No. 1 Exposure to 120°F/75% RH Absorb and 120°F/0% RH Desorb for Specimen GFD	137
A-49	Cycle No. 2 Exposure to 120°F/75% RH Absorb and 120°F/0% RH Desorb for Specimen GFD	138
A-50	Cycle No. 1 Exposure to 120°F/75% RH Absorb and 120°F/0% RH Desorb for Specimen HFD	139

LIST OF TABLES (Continued)

<u>Table</u>	<u>Title</u>	<u>Page</u>
A-51	Cycle No. 2 Exposure to 120°F/75% RH Absorb and 120°F/0% RH Desorb for Specimen HFD	140
A-52	Cycle No. 1 Exposure to 120°F/75% RH Absorb and 120°F/0% RH Desorb for Specimen IFD	141
A-53	Cycle No. 2 Exposure to 120°F/75% RH Absorb and 120°F/0% RH Desorb for Specimen IFD	142
A-54	Cycle No. 1 Exposure to 160°F/98% RH Absorb and 160°F/0% RH Desorb for 13-Ply Specimen A	143
A-55	Cycle No. 1 Exposure to 160°F/98% RH Absorb and 160°F/0% RH Desorb for 13-Ply Specimen B	144
A-56	Cycle No. 1 Exposure to 160°F/98% RH Absorb and 160°F/0% RH Desorb for 13-Ply Specimen C	145
A-57	Cycle No. 1 Exposure to 160°F/98% RH Absorb and 160°F/0% RH Desorb for 13-Ply Specimen D	146

1.0 INTRODUCTION

It has been shown that high performance resin matrix composite materials are susceptible to degradation in environments to which aircraft are subjected (References 1, 2). Developments in the application of polymeric matrix composites to military aircraft structures have revealed significant changes in the mechanical properties and dimensional shapes of these materials due to the effects of combined moisture and thermal environments (Reference 3). The absorbed moisture in composites causes the resin to swell, inducing internal stresses. Moisture gradients and the resulting nonhomogeneous swelling of the resin can lead to the formation of microcracks and delaminations. Additionally, water acts as a plasticizer in a polymer matrix, reducing the glass-transition temperature, that is, the temperature at which there is a dramatic loss of matrix modulus.

Since moisture adversely affects resin-matrix composite materials, it becomes necessary to know how much moisture a given piece of composite structure has absorbed at a certain point in time, whether in the laboratory under controlled conditions, or in actual service under widely varying conditions. This becomes easy enough in the laboratory case (by periodically weighing the specimens) if one accounts for such variables as moisture absorbing end tabs, bonding adhesive, sealant, paint, metal splice plates, and fasteners. However, the problem becomes more difficult if moisture distributions through the specimen thickness are required, since weighing establishes only the average moisture content in the specimen. Also, specimens may be located in the field, away from equipment for weighing; and larger, full-scale aircraft structure, such as a flap, empennage, wing, etc. must be removed from the aircraft for such weighing. Obviously, another method of moisture determination that is accurate and convenient is needed since moisture content and distribution in composite materials in the field must be determined and monitored in order to extend the confidence level in current composite design methods to primary structural components. As a result of independent research and development work at the Lockheed-Georgia Company, a promising new method for determining the moisture content and distribution in composite materials by the use of dielectric measurements has evolved.

The objectives of this program were to quantify the relationship between moisture content and capacitance change in T300/5208 graphite/epoxy material, and to utilize this relationship to determine the moisture distribution in a typical laminate of the same material.

The program was conducted in two tasks. Task I was an empirical and analytical effort conducted on three-ply graphite/epoxy laminates subjected to various environmental exposure conditions. A quantitative relationship between moisture content and capacitance change in the specimens was established. Task II used the results of Task I to verify the use of this methodology for determination of moisture distributions during absorption and desorption of 13-ply laminates. These measured moisture distributions were compared to theoretical values for the same laminate configuration.

2.0 TECHNICAL DISCUSSION

2.1 EXPERIMENTAL TEST PROGRAM

This program has been conducted in two tasks. In Task I, three-ply graphite/epoxy laminates with sensors embedded at their midplanes were exposed to various hygrothermal environments. Moisture content versus time was determined by weight measurements at discrete times during each exposure condition. In addition, capacitance readings were measured by the sensors at those same times. The capacitance was then converted to percent change at each time period and compared with the laminate moisture content. From the measured weight gain data, an analytical least squares curve fit program was used to establish the moisture diffusion coefficients necessary to then analytically establish the moisture content at the laminate midplane at the discrete weight and capacitance measurement times. This procedure established a relationship between capacitance and local moisture content. A similar procedure was used in Task II except that the graphite/epoxy laminates were thirteen plies thick and six sensors were placed through the thickness as discussed in Paragraph 2.1.2.2. The local moisture content/capacitance relationship with these Task II specimens were evaluated and compared with the results obtained in Task I.

2.1.1 Materials and Equipment

2.1.1.1 Laminate Material - The graphite/epoxy laminate material selected for use throughout the program was T300/5208. This selection was based on its widespread use throughout the aerospace industry.

2.1.1.2 Capacitance Sensor and Meter - The capacitance sensing probe consisted of a pair of coated parallel 0.003-inch diameter magnet wires as illustrated in Figure 1. They were constructed from Phelps-Dodge armored Poly-Thermalize 2000 40-gauge magnet wire insulated with thermosetting polyester overcoated with a linear amide-imide and were installed in the specimen in intimate contact with each other. The wires acted as the "plates" of a capacitor while the resin between them constituted the moisture tracking dielectric. Extension of the sensor wires beyond the edge of the specimen

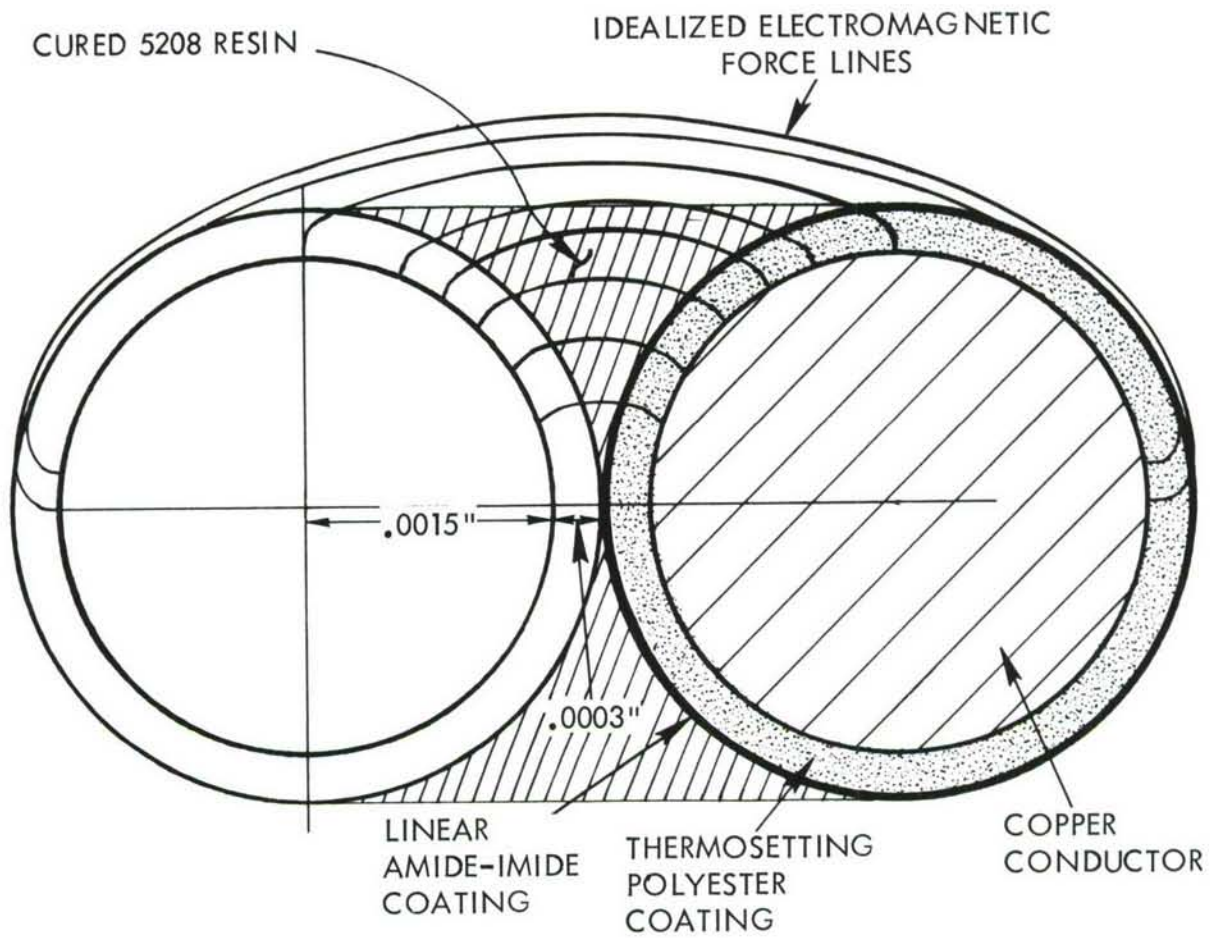

Figure 1. Capacitance Sensor Detail

constituted the sensor leads necessary for interconnection to the monitoring instrumentation. An E.C.D. Model 100 digital capacitance meter was used to measure the capacitance at the sensor. The meter is auto-ranging and can very quickly measure capacitance values as low as 0.1 pico-farad (pf). The meter is also highly portable, as shown in Figure 2.

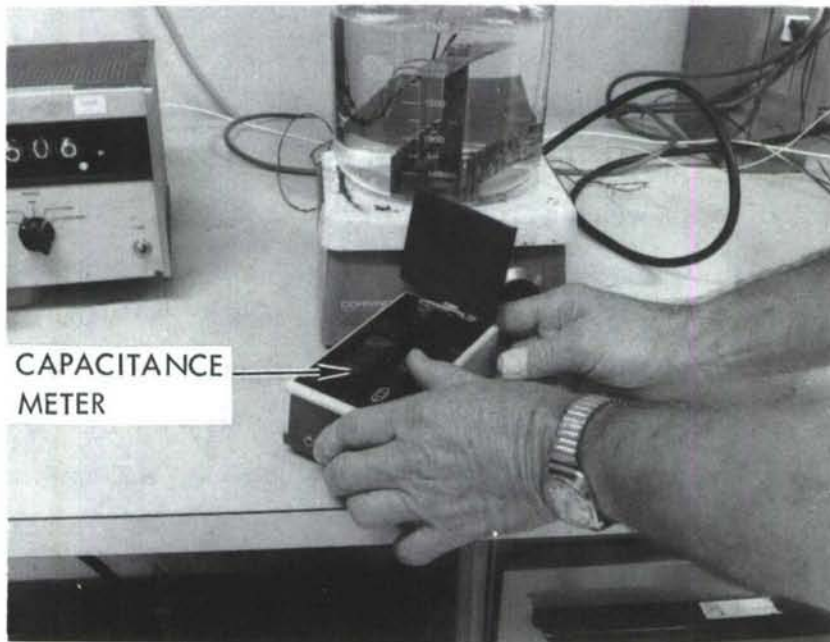

Figure 2. Portable Capacitance Meter

2.1.1.3 Environmental Test Equipment - The absorption chamber was a Blue M FR-256PC-1 Model as shown in Figure 3. The system incorporates a noncycling, constant refrigeration principle and was capable of operating over the ranges required for this program. The system was installed with a stainless steel reservoir and water purification system and therefore operated from tap water. Several sets of precision cams were machined and verified to precisely control the equipment for the various temperature/relative humidity requirements of this program. The equipment incorporated a 3-inch port in the top in order to allow leads from the specimens and sensors to extend out of the chamber to a special hook affixed to the weighing pan of a digital analytical scale in order to weigh the specimens while in the chamber. During non data

taking intervals the port was stoppered with a 3-inch rubber plug. The 0.003-inch probe wires wedge easily between the port walls and the rubber plug. The desorption chamber, shown in Figure 3 and on a larger scale with the temperature readout equipment in Figure 4, was an aluminum chamber with inside dimensions of 6 inches by 4 inches by 6 inches and incorporating an integral thermostatically controlled heating element. The chamber has an airtight removable top with ports, in order to allow weight and capacitance readings to be made while the specimens are still in the chamber. The temperature is monitored with a precise digital thermometer.

2.1.1.4 Analytical Balance and Support Fixture - The analytical balance bought for this program was a Mettler H315 with digital readout. The system operates by the optical tare principle with a weighing range between 0-1000 grams. It has a readability of 0.1 mg and a standard deviation precision of ± 0.1 mg. However, since it could not be properly calibrated, it was returned to the factory and a Christian-Beckman analytical balance of equal accuracy was substituted in its place. A special fixturing hook designed to clip on to the weighing pan permits the weighing of specimens outside the weighing chamber and underneath the balance, as shown in Figure 3.

As shown in Figure 3, the digital analytical scales were mounted on a 1-inch thick aluminum plate which is bolted to four Thompson linear bearings. These bearings travel on 1-inch precision ground stock which is mounted on a bridge assembly bolted to a double thick concrete wall. The entire assembly is suspended over the top of the absorption and desorption chambers. This configuration allows the balance to be precisely placed over the ports of the absorption chamber and desorption chamber for weighing of specimens without removal from the chambers. This test setup also reduces the effect on analytical scale readings of vibrations from the humidity cabinet and floor.

2.1.2 Specimen and Sensor Configuration and Fabrication

2.1.2.1 Sensor Configuration and Fabrication - Pairs of parallel magnet wire described in Paragraph 2.1.1.2 were strung tightly in a multiple "fiddle bow" type of fixture, shown in Figure 5, to insure a consistent "plate" separation dimension. Each

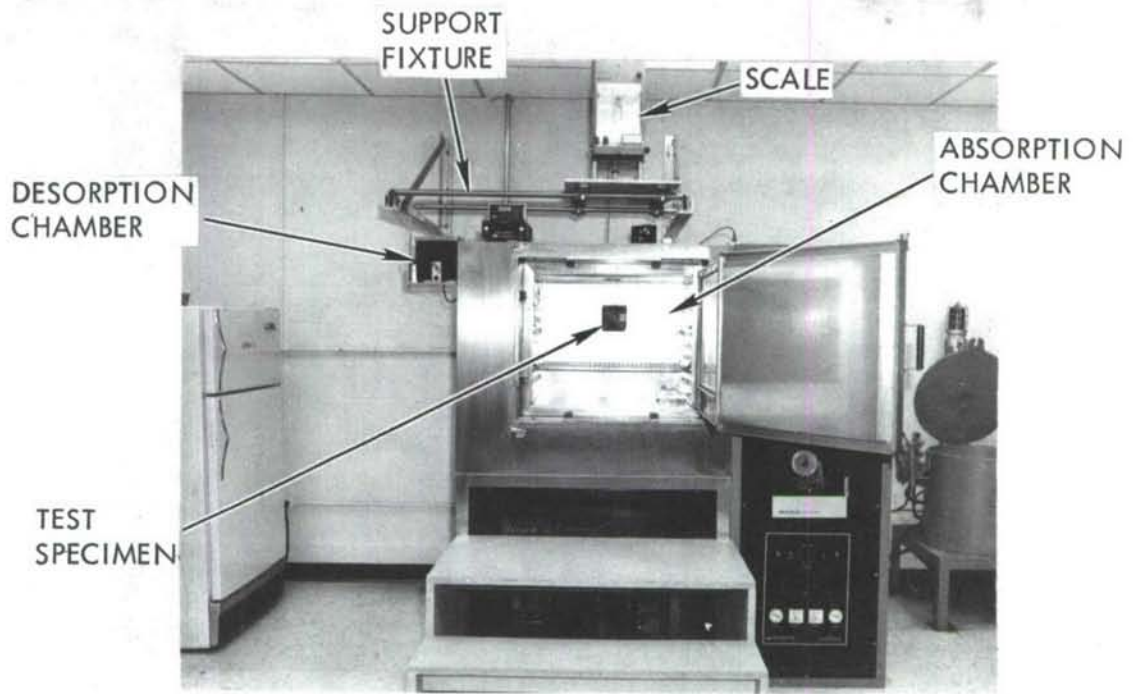

Figure 3. Environmental Test Equipment

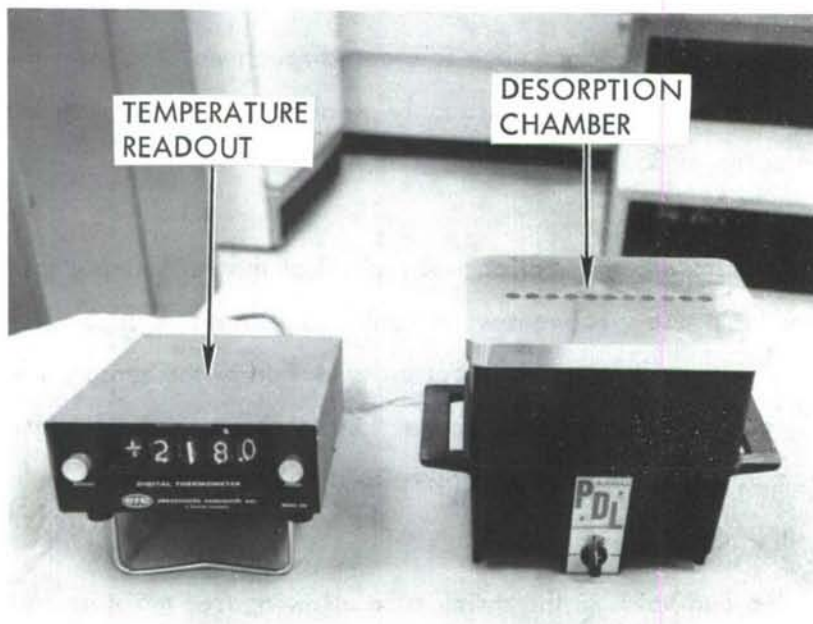

Figure 4. Desorption Chamber and Temperature Readout

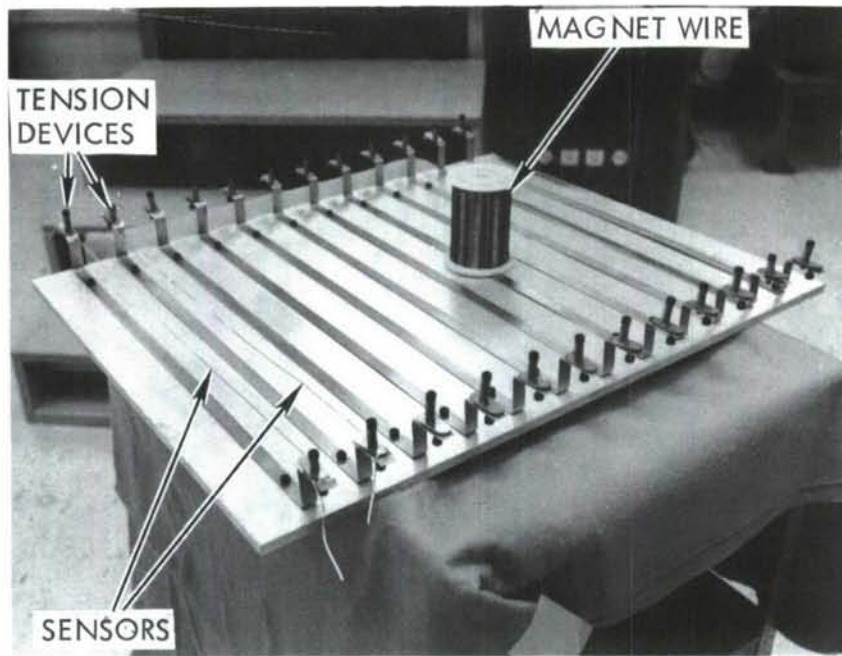

Figure 5. Sensor Fabrication Fixture

pair of wires were of sufficient length such that, when cut, they formed two sensors. Since the fixture will hold 12 such pairs, each fixture lay-up provided enough probes for 24 3-inch by 3-inch specimens. Three sections of mylar shrink tubing were slipped concentrically around the wire pairs in such a manner that there was a one-inch monitored section in the center of each fabricated specimen, as shown in Figure 6. The 1-inch monitoring section was thoroughly cleaned and coated with Narmco 5208 resin and oven cured at 350°F.

This sensor and specimen configuration was typical of the early 3-ply specimens and designated Type I. These specimens were numbered with an A or B after the number, e.g. 1B and 2A. Figure 7 shows a typical cross section of the sensor, the shrink tube, and the three graphite/epoxy laminate plies. The problems and difficulties encountered with this configuration during exposure to the various temperature/humidity environments included:

- o Cracking and voids in the shrink tube allowing free moisture in the area of the sensors.

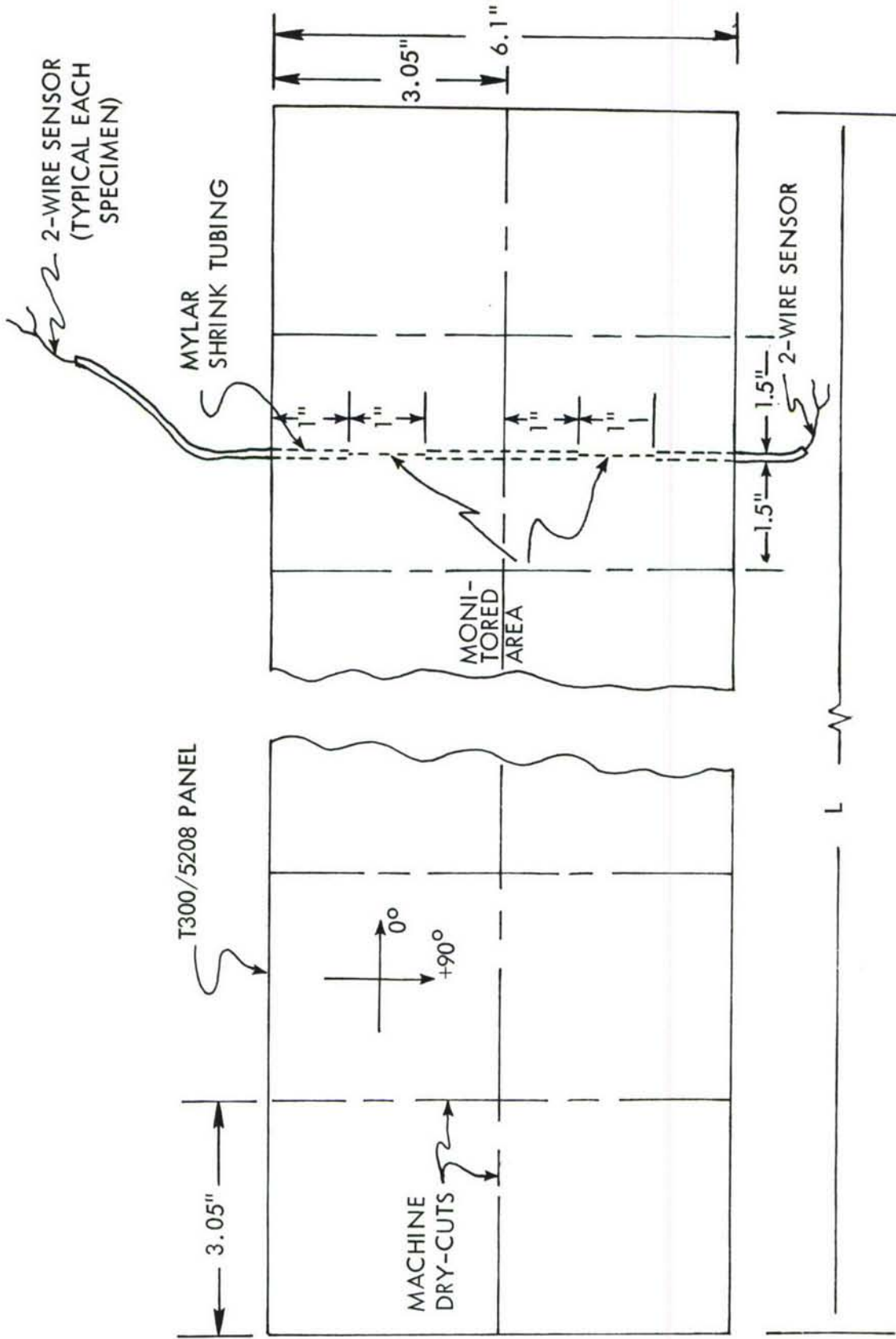

Figure 6. Early Sensor/Specimen Configuration

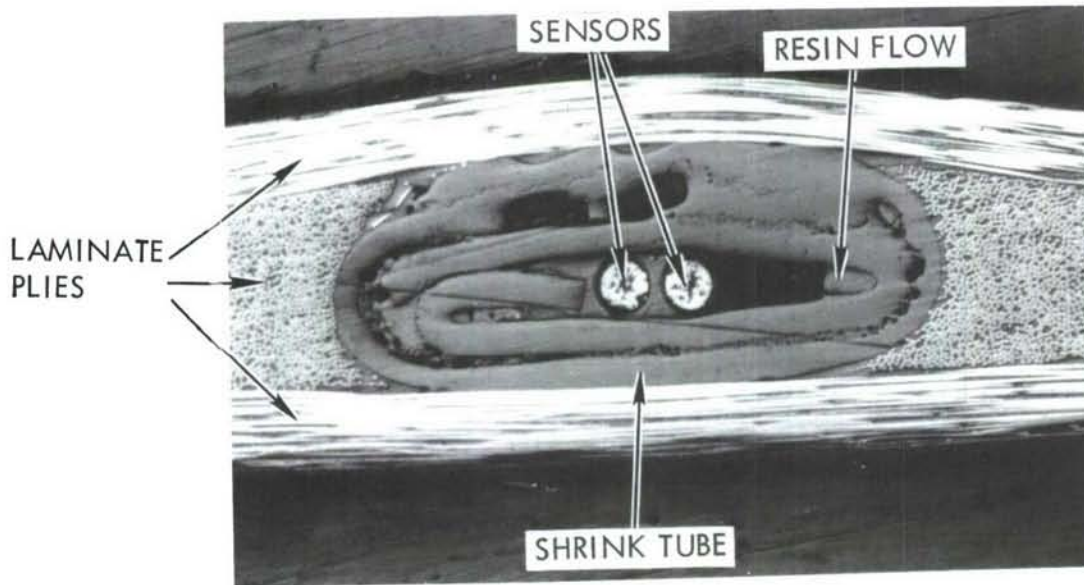

Figure 7. Early Specimen and Sensor Installation

- o Moisture accumulating inside the shrink tube causing erratic moisture content calculations.

As a result of the difficulties with the original sensor design, a number of modifications were made in arriving at the final design shown in Figure 8. This design was used in the nine 3-ply specimens, AFD through IFD. In this final design, designated Type IV, two wires were twisted for about a two-inch section and made into a loop which was finally placed in the specimen as shown in Area B of Figure 8. The loop and lead wire details are shown in Figure 9 and then become the Capacitance Sensor. Figure 10 shows a cross section through the loop of one of the sensors showing the four copper wires. The lead wires (from the loop) were prefabricated into the brass tube. The lead wires from the brass tube to the pins that plug into the capacitance meter were pre-molded with silicone rubber to prevent moisture entry from that end.

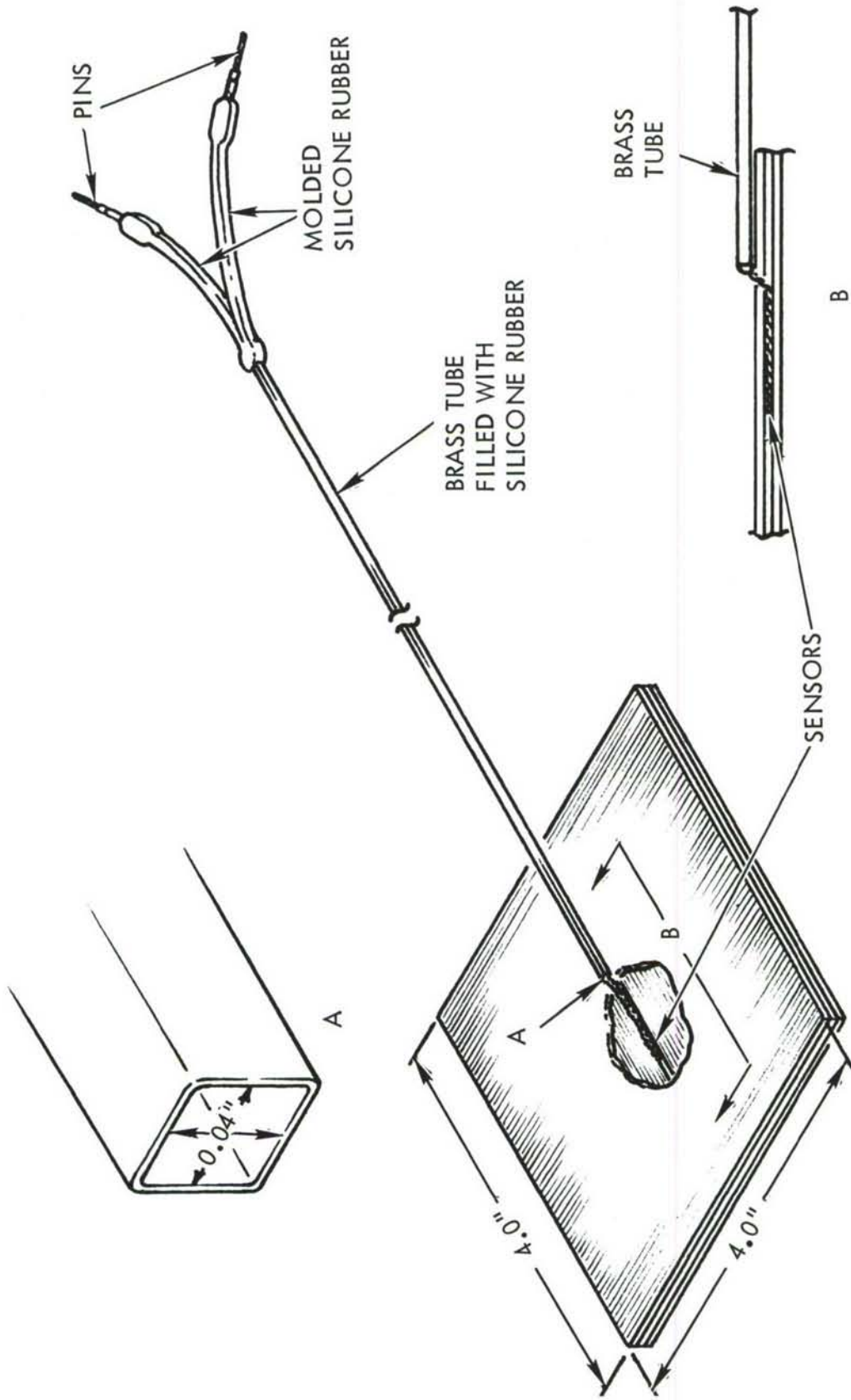

Figure 8. Final Design for Environmental Exposure Specimen and Sensor

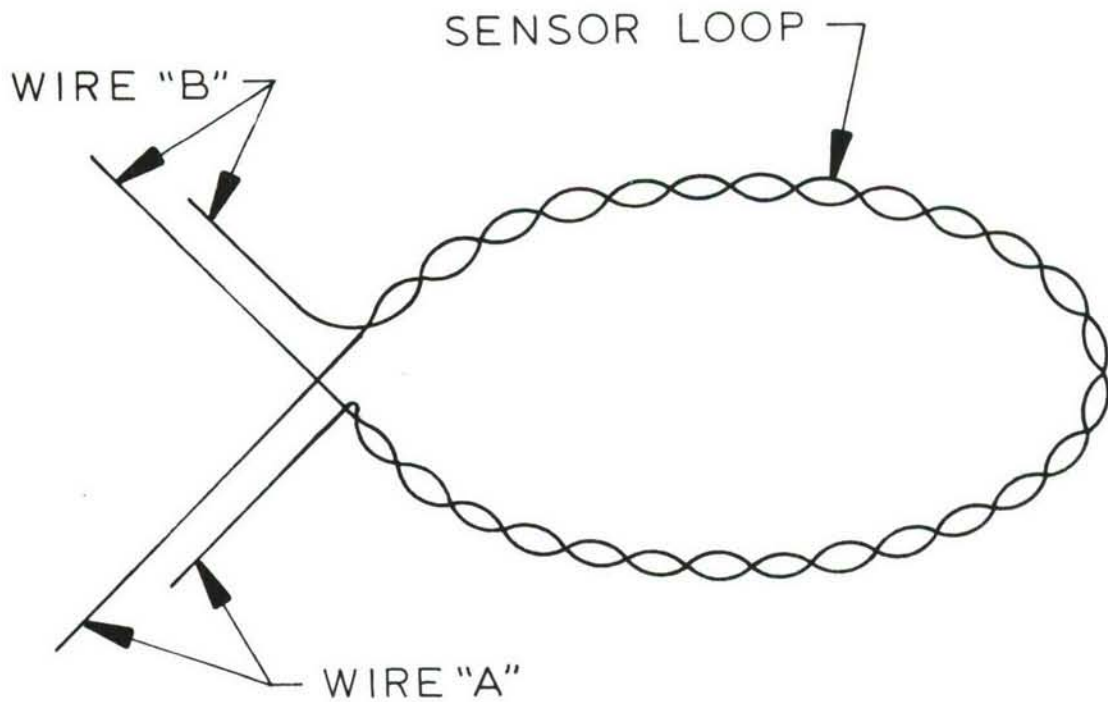

Figure 9. Sensor Loop and Lead Wire Detail

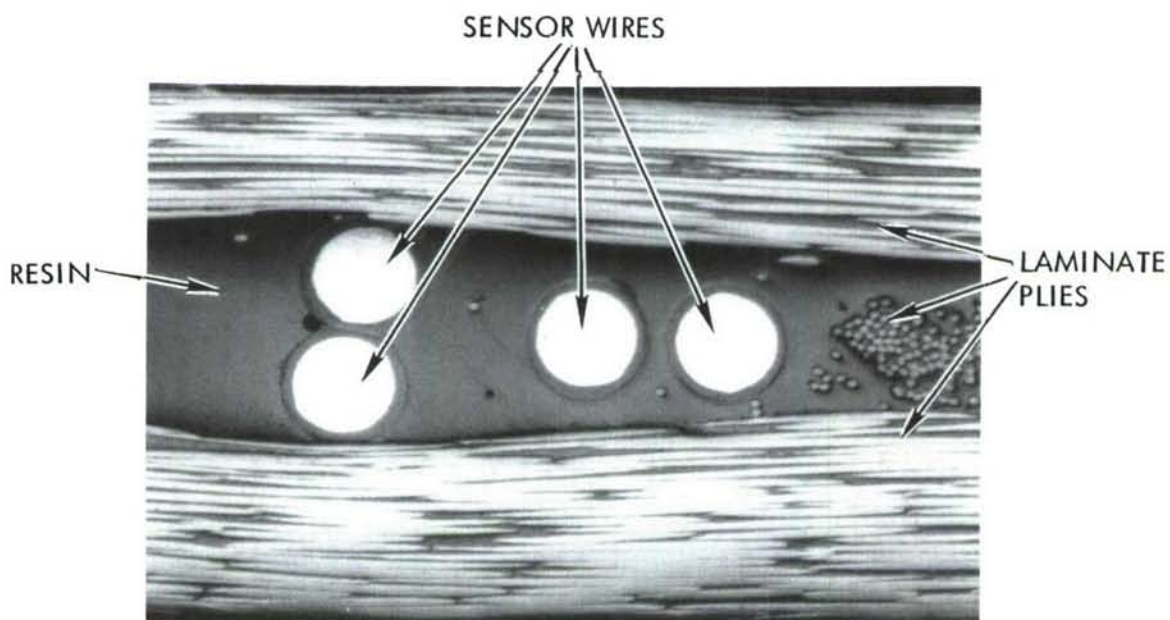

Figure 10. Cross Section of the Sensor Final Design

Two modifications of the "final design" sensor were used prior to its use in Specimens AFD through IFD. The first modification was used in Specimens 13, 17, and 21 which were exposed to 160°F/75% relative humidity (RH) during absorb and 160°F/20% RH during desorb and which were designated Type II. In this modification, the sensor loop was installed in the specimen with the lead wires emerging from the bag side. Shrink tubing was placed around the lead wires instead of the brass tubing. Another length of shrink tube was placed around the wires from the first shrink tube to the pins instead of the molded silicone rubber.

The second modification was designated Type III and was essentially the same as the first except that an aluminum tube was substituted for the shrink tube on the lead wires emerging from the specimen. The lead wires were potted into the aluminum tube with a silicone rubber. This design was used for the 3-ply Specimens 29, 30, 31, 32, 33, and 35 and for the 13-ply Specimens A, B, C, and D.

2.1.2.2 Specimen Configuration and Fabrication - All 3-ply specimens were fabricated in the orientation of 0, 90, 0 with the sensor placed in the center ply. The sensor configuration did change as discussed in Paragraph 2.1.2.1 above.

The 13-ply Specimens A, B, C, and D were fabricated in two orientations. Specimens A and B were oriented $[0, 90, 0, 0, 90, 0, 90, 0, 90, 0, 90, 90, 0]_T$ starting from the tool side. The six sensors were placed in Ply Numbers 2, 5, 7, 8, 10, and 12, starting from the tool side so that four sensors (Numbers 1, 2, 3, and 6) were parallel with and in the 90° Ply Numbers 2, 5, 7, and 12 and two sensors (Numbers 4 and 5) were parallel with and in the 0° Ply Numbers 8 and 10. Specimens C and D were oriented $[(0, 90)_6, 0]_T$. The six sensors were placed in each of the 90° oriented plies so that the sensors were numbered 1 through 6 corresponding with Ply Numbers 2, 4, 6, 8, 10, and 12, with Ply Number 1 being next to the tool.

Physical properties determined after fabrication of each of the panels were consistent with well fabricated T300/5208 graphite/epoxy laminates. Average physical properties were as follows:

	<u>3-Ply</u>	<u>13-Ply</u>
Specific Gravity (g/cc)	1.57	1.56
Fiber Volume (%)	62.0	60.0
Void Content (%)	<0.1	<0.1
Per Ply Thickness (in.)	0.0055	0.0056

Visual and microscopic examination of the fabricated specimens revealed sound installation of the sensors and very low void content laminates. Figure 7 shows a cross section through the shrink tube, the two-wire sensor, and the three plies of the Type I specimens with a letter following the number. Voids and/or cracks and resin flow into the shrink tube is evident in the Figure 7 photomicrograph. Figure 11 shows a cross section of the same specimen sensor installation at the actual 1-inch sensor measurement area. This cross section shows a sound sensor installation and a sound laminate. Figure 10 shows a cross section through the four wires of the Type IV specimen representative of the nine specimens AFD through IFD. This also shows a sound sensor installation with a well fabricated laminate.

Figure 12 shows the four 4-wire Type III sensor installations located in the 90° plies of the 13-ply Specimen A. The other two 4-wire sensors located in the 0° plies of 13-ply Specimen A are shown in Figure 13. Although the field of view is insufficient to see all six sensors, Figure 14 shows typical installations of part of the six sensors of 13-ply Specimen C. Figure 15 shows a typical close-up of one of the installations for Specimen A and Figure 16 shows a typical close-up of one of the installations for Specimen C. Since Specimens A and B are oriented alike and Specimens C and D are oriented alike, Figures 12 through 16 are representative of the 13-ply Specimens A, B, C, and D. It is evident from these five photomicrographs and the physical property examination described above that the sensor installations are sound and that the laminates are well fabricated.

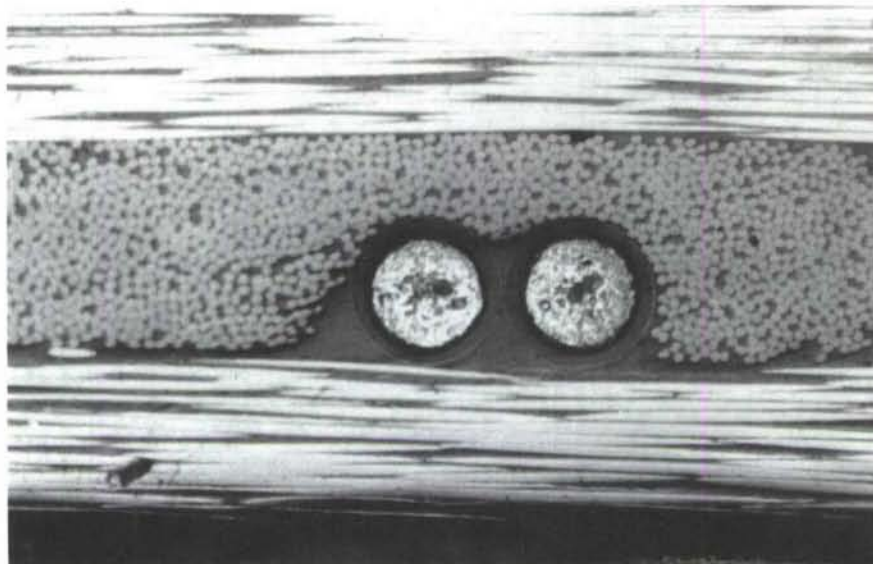

Figure 11. Sensor Installation in Early 3-Ply Specimens

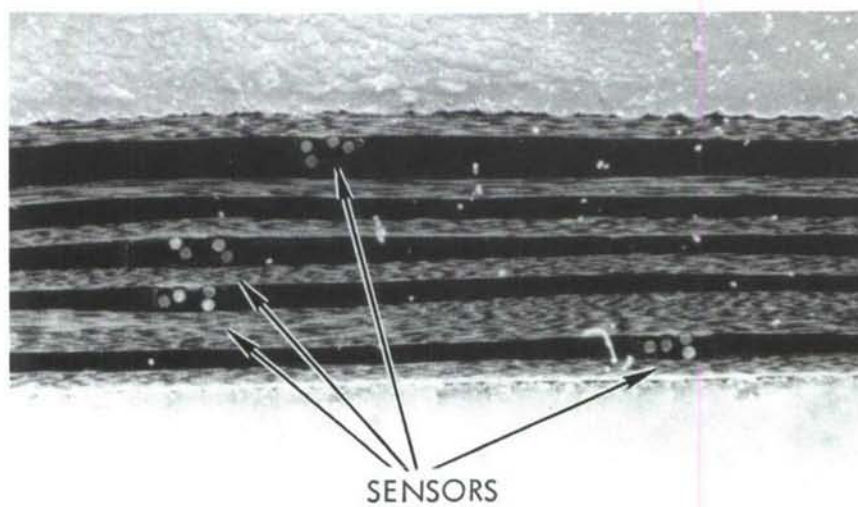

Figure 12. Four Sensor Installations in 13-Ply Laminate A

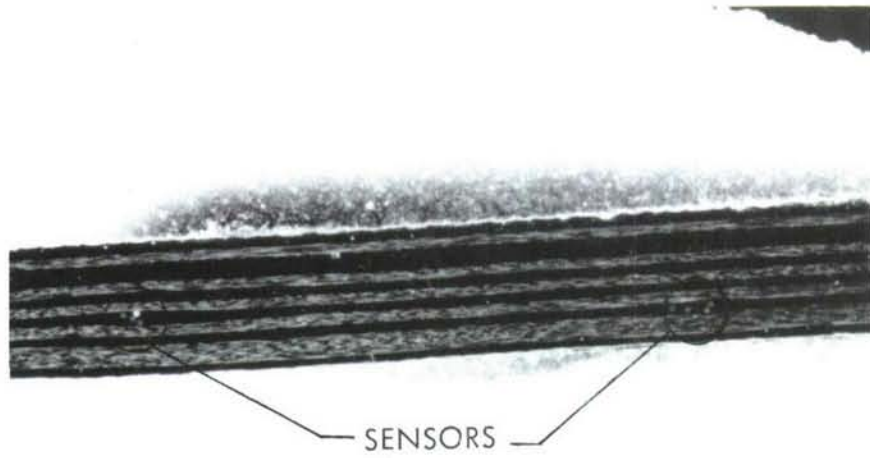

Figure 13. Two Sensor Installations in 13-Ply Laminate A

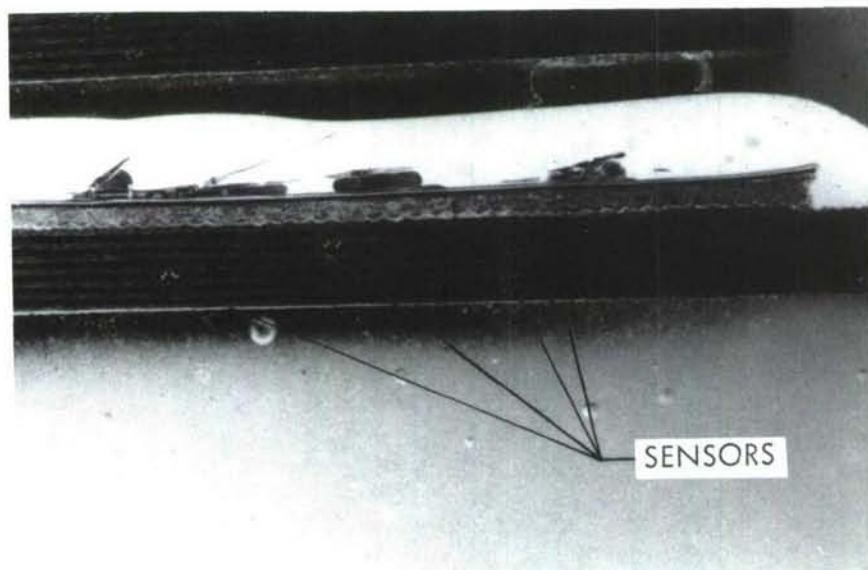

Figure 14. Typical Sensor Installations for Specimen C

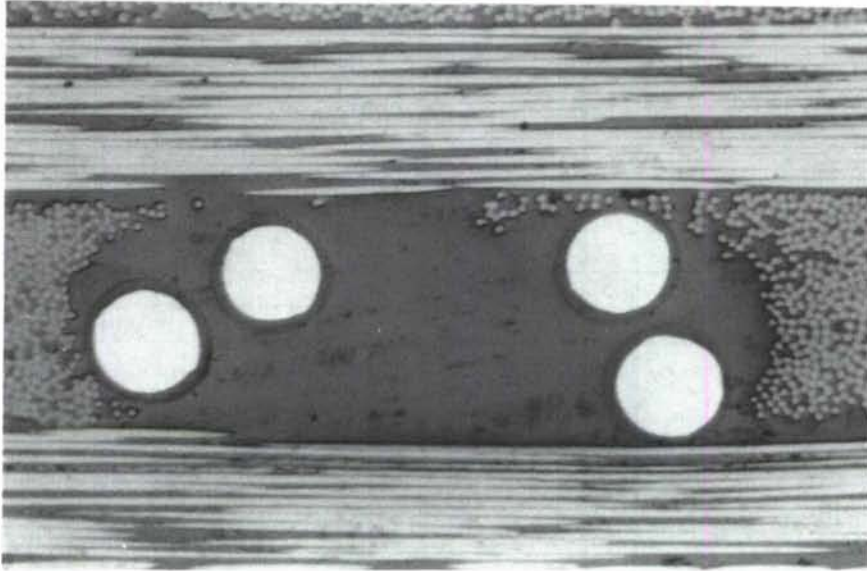

Figure 15. Close-up of a Typical Sensor Installation of Specimen A

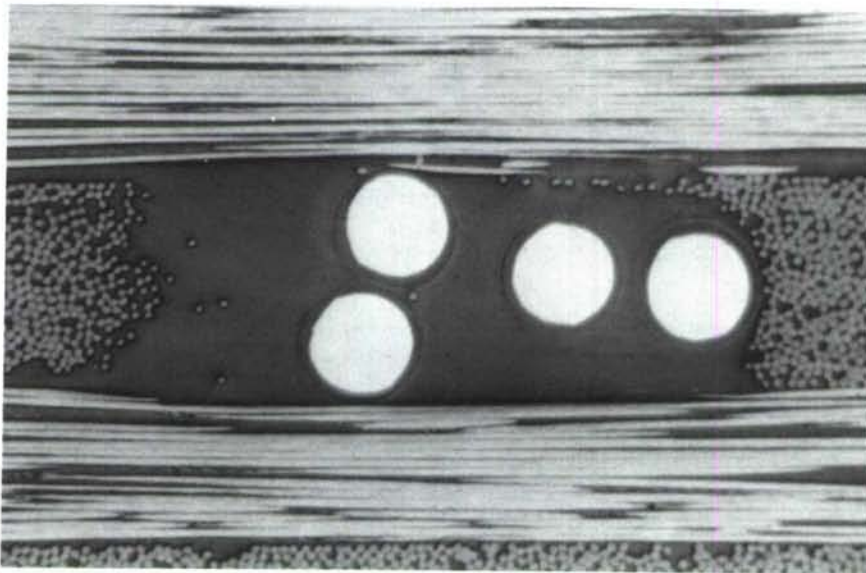

Figure 16. Close-up of a Typical Sensor Installation of Specimen C

2.1.3 Environmental Testing and Procedures

2.1.3.1 Temperature/Humidity Environmental Testing - The 3-ply specimens were exposed to the temperature/humidity environmental conditions shown in Table 1.

TABLE 1. ENVIRONMENTAL CONDITIONS

NO. OF CYCLES	ABSORB		DESORB	
	Temp. (°F)	Humidity (% RH)	Temp. (°F)	Humidity (% RH)
2	RT	93	RT	0
2	RT	75	RT	0
1	RT	50	RT	0
2	120	98	120	0
2	120	75	120	0
2	120	50	120	0
2	160	98	160	0
2	160	75	160	20
1	160	50	160	0
1	160	98	160	50

The 13-ply specimens were exposed to one cycle of 160°F/98% RH Absorb and 160°F/0% RH Desorb.

The test sequence, specimen type, and specimen numbers used for each environmental condition are shown in Table 2.

Specimen 8B was the only specimen used for two exposure conditions. The capacitance lead wire broke after 6.25 hours of the second absorb cycle to its first use at 120°F/50% RH absorb and 120°F/0% RH desorb. Fortunately, the sensor leads broke far enough away from the specimen that repair was possible. Since its first exposure condition was rather mild at 120°F/50% RH and the second use was also mild (RT/50% RH), it was decided to allow it to become the third specimen for that exposure condition.

TABLE 2. ENVIRONMENTAL TEST SEQUENCE

TEMP. (°F)	ABSORB RH	DESORB RH	NO. PLIES	SPEC. TYPE	SPECIMEN NUMBERS TESTED
120	98	0	3	I	3B, 6B
120	50	0	3	I	3A, 8B
120	98	0	3	I	1B, 2A, 14A
RT	50	0	3	I	4B, 8A, 8B
160	75	20	3	II	13, 17, 21
160	98	0	3	III	29, 31
160	98	50	3	III	32, 33
160	50	0	3	III	30, 35
160	98	0	13	III	A, B, C, D
RT	93	0	3	IV	AFD, BFD, CFD
RT	75	0	3	IV	DFD, EFD, FFD
120	75	0	3	IV	GFD, HFD, IFD

2.1.3.2 Weighing and Capacitance Measurement Procedure - Weighing and capacitance measurements require approximately 10 minutes for each specimen at each discrete time period. Therefore, each specimen starting time is staggered by 10 minutes so that the exposure time period is the same for each specimen.

Early experiments with taking the weights and the capacitance measurements in the environmental chamber during absorption with the air circulating fan on and off showed better results with the fan on. This procedure was used for the 3-ply specimens of Types I, II, and III. Because of condensation problems encountered caused by using that procedure in combination with condensation in the port area where the capacitance lead wires emerged from the environmental chamber, it was decided to drop the environmental condition below the room temperature dew-point condition during weighing and capacitance measurements. This was accomplished and used on the 13-ply Specimens A, B, C, and D which were exposed to 160°F/98% RH during absorb and the Type IV 3-ply Specimens GFD, HFD, and IFD which were exposed to 120°F/75% RH during absorb. With the environmental chamber environment below the dew point during data taking, best results were obtained with the air circulating fan off.

Weighing Procedure

- o Examine balance to ascertain that it is in proper operating condition to include cleaning and leveling.
- o Determine the point of rest (zero point) of the empty balance.
- o Determine and record the tare weight.
- o Perform the weighing of the specimen utilizing the restoring to the original point of rest method described below.

Connect the specimen to the center of the aluminum rod adapter (used in place of left pan) and place on the center of the right pan a weight thought to be approximately equal to that of the specimen. Release the adaptor and pan rests. If there is any swinging of the adaptor and pan, arrest this motion by successive application of the pan rests. Slowly lower the beam until the first motion of the pointer indicates whether the applied weight is too large or too small. Systematically, add or remove weights, arresting the beam and pan supports between each change and taking care to prevent oscillation of the adaptor and pan, until the specimen is balanced within the range of the circularly shaped weight mechanism. Visually estimate the point of rest by noting the extremes of the first full swing. From this approximate value of the point of rest and the value of the zero point of rest, make a mental calculation of that position of the circularly shaped weight mechanism which will restore the point of rest to the zero value. Shift the circularly shaped weight control knob to this calculated position and repeat this process until a final point of rest is obtained which is coincident with the zero point of rest within the limits of accuracy desired for the weighing. Raise the beam and release the pan support rests. Repeat this method three times. Disconnect specimen from adaptor and place back in chamber.

- o Record the individual weights on the pan and the value of the circularly shaped weight mechanism. Check this list against the weights missing from the weight box. Return the weight to the pan again checking the original list. Add the total value of the weights.

Capacitance Measurement Procedure

- o Examine capacitance measurement meter to ascertain that it is in proper operating condition to include properly charged batteries.
- o Calibrate meter to insure the correct zero point, by adjusting the capacitance off-set knob to zero.
- o Calibrate meter using a standard 903 pf polystyrene reference capacitor.
- o Check specimen to insure it is free from touching other specimens in chamber, to include leads and thermal check-out.
- o Connect specimen leads to meter inlet and press measurement button.
- o Read capacitance digital read-out in meter's window.
- o Repeat procedure three times to insure correct reading.

2.1.4 Analytical Moisture Model

The one-dimensional Fick diffusion equation

$$\frac{\partial M(z, t)}{\partial t} = D \frac{\partial^2 M(z, t)}{\partial z^2} \quad (1)$$

where

$M(z, t)$ = moisture content (% by weight) at position z in the interior of the laminate and time t

D = diffusion coefficient

is solved by assuming a solution of the form

$$M(z, t) = [A \sin a_n z + B \cos a_n z] e^{-(a_n^2 Dt)} \quad (2)$$

where

$$a_n = \frac{(2n + 1)\pi}{h}$$

h - laminate thickness

Making this substitution and evaluating boundary and initial conditions leads, after some mathematical manipulation to the solution

$$M(z, t) = M_o + (M_{amb} - M_o) \left[1 - \sum_{n=0}^{\infty} m_n \cos a_n z \right] \quad (3)$$

where

M_o = the initial moisture content of the laminate

M_{amb} = the ambient (saturated) moisture content

$$m_n = \frac{4}{\pi} \left[\frac{(-1)^n}{2n+1} e^{-(a_n^2 Dt)} \right]$$

and

a_n = as previously defined

Although the cosine series is shown summed to infinity, numerical comparison of results, with the given ranges of initial and boundary conditions, showed that convergence is obtained by taking the first twelve terms. The restriction on the exposure condition is that it must be symmetric, i.e., the same temperature and humidity must be present on both sides of the laminate.

A supplemental program was developed to aid in providing certain input data for the main moisture distribution program. The diffusion coefficient, D, given in the Fick diffusion equation can be expanded as follows:

$$D = D_o e^{\left(-\frac{E}{RT}\right)}$$

where

D_0 is the permeability index of the material

E is the activation energy

R is the universal gas constant

T is the exposure temperature in $^{\circ}\text{K}$

At the present time, there exists some disagreement among researchers as to the proper value of the diffusion coefficient D of various laminate systems. As a result, there can be found in the literature different values of the diffusion coefficient used by different authors for the same material.

It was decided, therefore, to develop a method by which actual test data giving moisture content versus exposure time for a certain laminate could be used to numerically calculate a value for the diffusion coefficient. The Diffusion Coefficient Estimation Program uses as input values of moisture content versus exposure time for a given laminate and exposure conditions. It correlates the measured data with the analytical solution in the least-squared error sense to provide a best fit value of diffusion coefficient for a given laminate.

The diffusion coefficients were determined for the three temperatures (RT, 120°F , and 160°F) from the actual time and weight data generated by the specimens exposed to those environments during this program. Since the capacitance sensors were placed in the center ply of all 3-ply specimens, it is assumed that the local moisture content would be that at the center of the specimen. Therefore, curves were drawn for the average moisture content and the local moisture content, versus the square root of time for each of the environmental conditions shown in Table 1, calculated by this moisture model using the diffusion coefficients as described above. These curves are given in the Appendix as Figures A-1 through A-20. Similar curves were drawn for the 13-ply laminates A, B, C, or D exposed to the environmental conditions of $160^{\circ}\text{F}/98\% \text{ RH Absorb}$ and $160^{\circ}\text{F}/0\% \text{ RH Desorb}$. These 13-ply laminates had six sensors placed through the thickness as described in Paragraph 2.1.2.2. The average moisture content and the local moisture content at five locations were plotted and are shown in Figures A-21 through A-26.

2.2 DISCUSSION OF TEST RESULTS

The test results are discussed in the sequence that they were obtained and as tabulated in Table 2, except that the 3-ply specimens of Task I will be discussed prior to the 13-ply specimens of Task II. The specimen weights, sensor capacitances, and times measured during the various exposures are tabulated as raw data in Tables A-1 through A-57 of the Appendix.

2.2.1 Task I Test Results

2.2.1.1 3-Ply Specimens Exposed to 120°F/98% RH Absorb and 120°F/0% RH Desorb -

Specimens 3B and 6B were the initial exposure specimens. The environmental conditions were 120°F/98% RH Absorb and 120°F/0% RH Desorb. The tabulated weight, capacitance and time data are given in Tables A-1 through A-4 for the two cycles. Figure 17⁽¹⁾ shows the average moisture content versus the percent capacitance change, and Figure 18 shows the local moisture content versus the percent capacitance change. As noted in Figures 17 and 18, capacitance during both absorption cycles was erratic and high. Capacitance during both desorption cycles was much more consistent. It was determined that the erratic readings were caused by moisture condensing and absorbing on the test leads. A length of Mylar shrink tubing encasing the entire length of the test leads improved this condition. Fifteen-pound test nylon monofilament was also encased in this length of shrink tube to add more rigidity to the leads for weighing.

Because of the erratic data observed from Specimens 3B and 6B, three additional specimens, 1B, 2A, and 14A, were modified as described above and exposed to this environmental condition of 120°F/98% RH Absorb and 120°F/0% RH Desorb. The tabulated weight, capacitance, and time data are shown in Tables A-5 through A-10 for the two cycles of each specimen. Figure 19 shows the average moisture content versus the percent capacitance change for all three specimens, and Figure 20 shows the local moisture content versus the percent capacitance change for the three specimens.

The data shows a different behavior for Specimen 1B than it does for Specimens 2A and 14A. Specimen 1B had a reasonable capacitance change with the laminate moisture

(1) Open symbols designate absorb and closed symbols designate desorb in all moisture/capacitance curves.

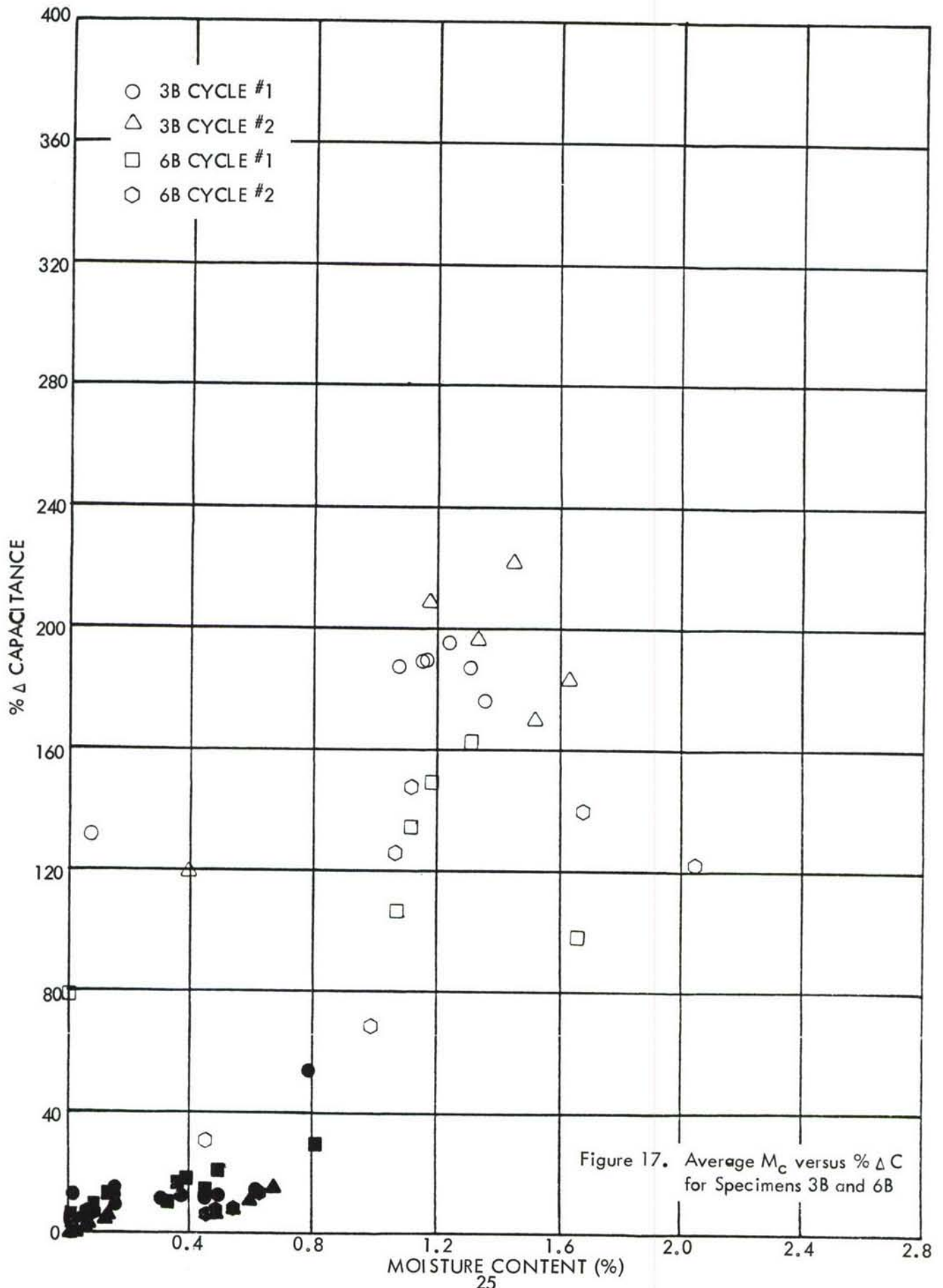

Figure 17. Average M_c versus % ΔC for Specimens 3B and 6B

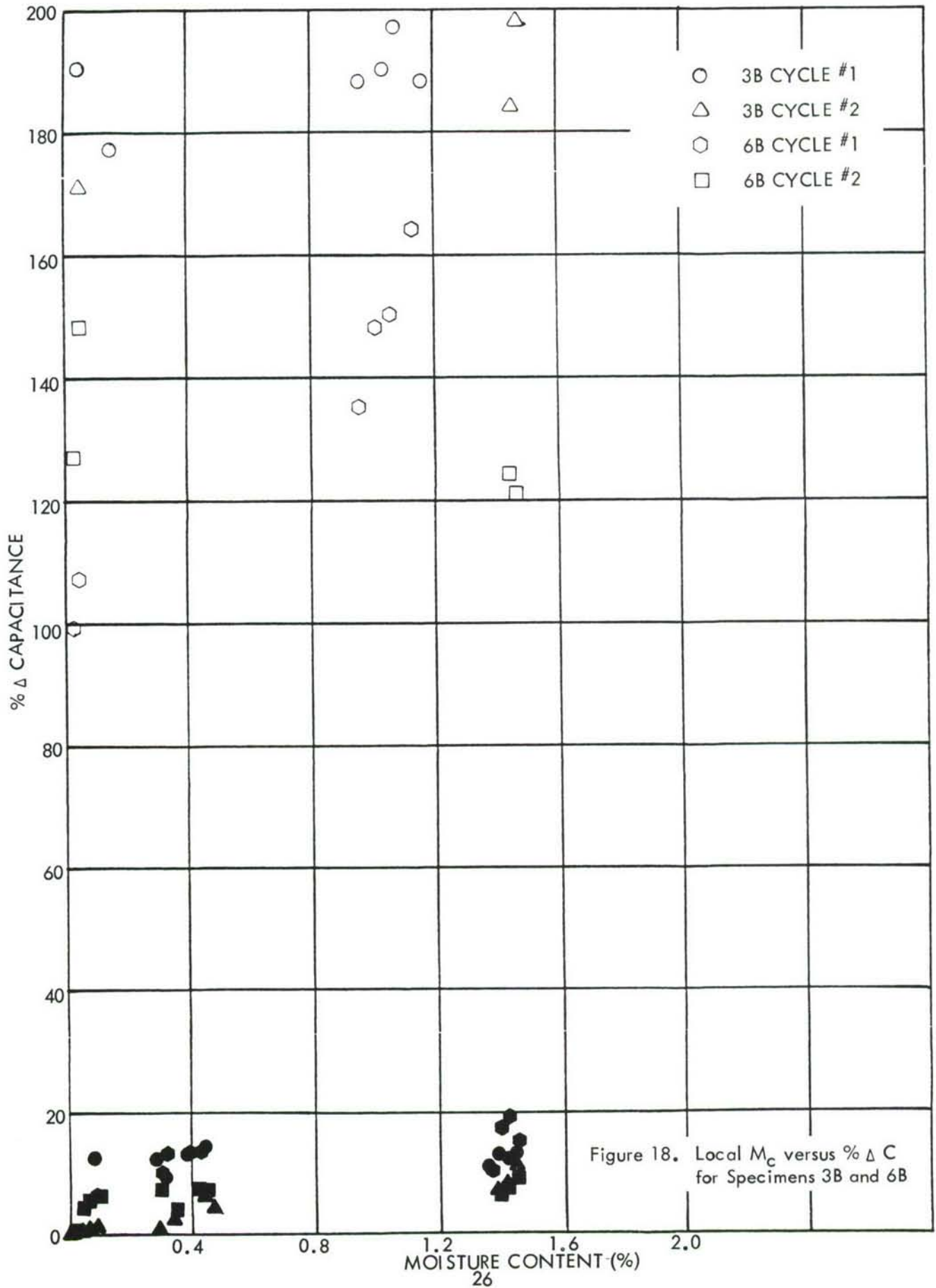

Figure 18. Local M_c versus % Δ C for Specimens 3B and 6B

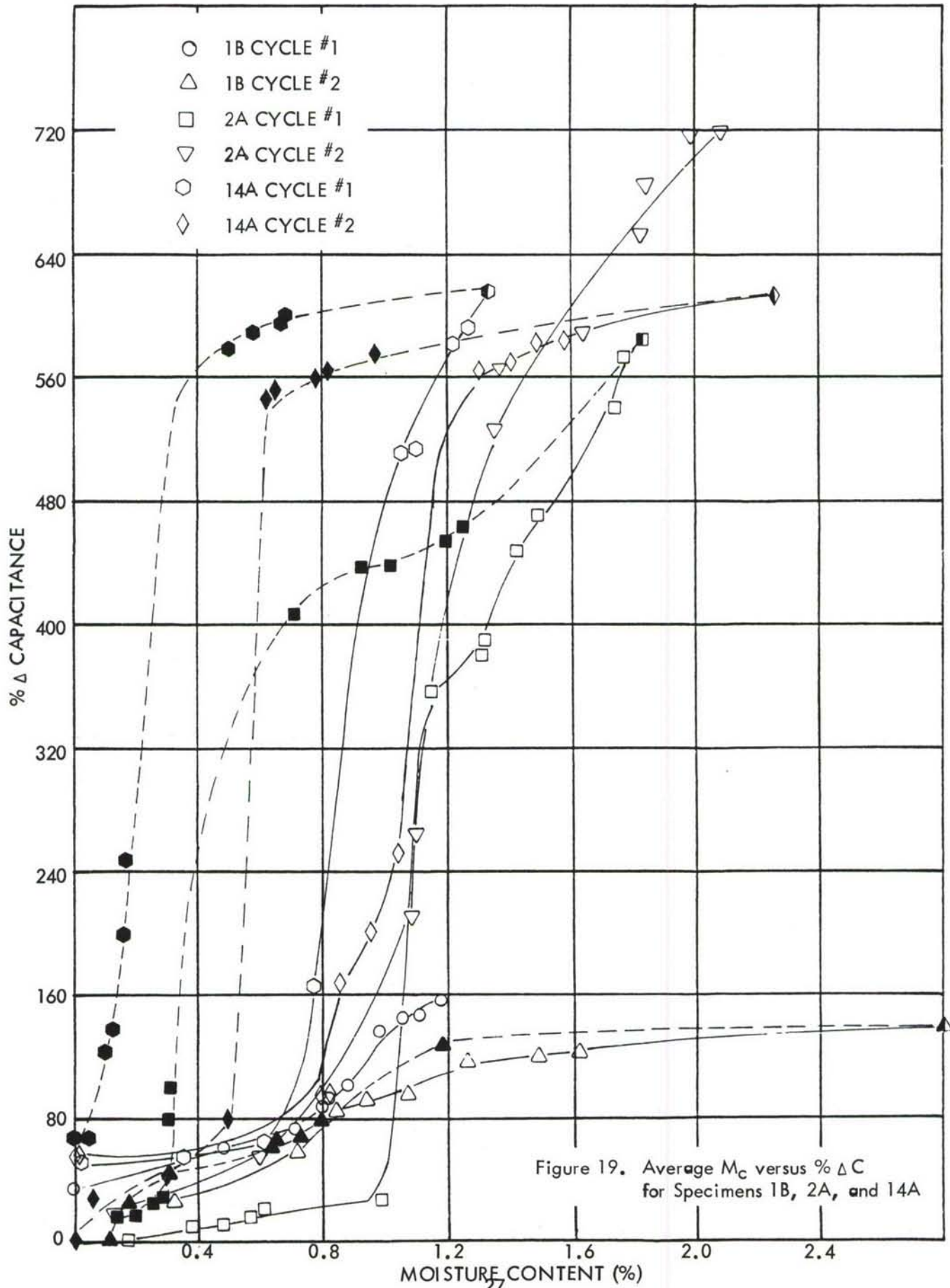

Figure 19. Average M_C versus $\% \Delta C$ for Specimens 1B, 2A, and 14A

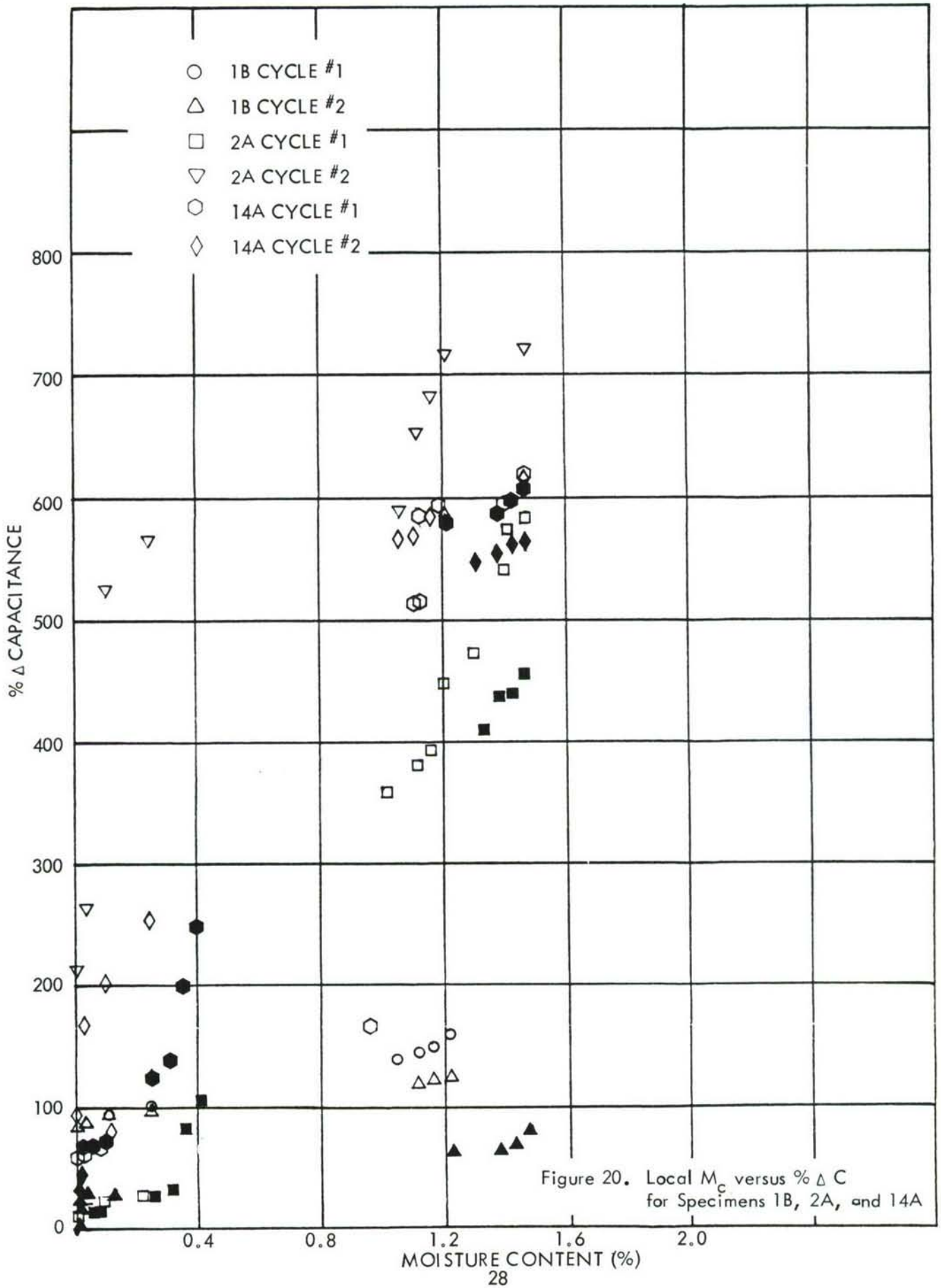

Figure 20. Local M_C versus % Δ C for Specimens 1B, 2A, and 14A

content. Specimens 2A and 14A had abnormally high capacitance changes with the higher moisture contents. This may be explained at least in part by examination of the three photomicrographs shown in Figures 21, 22, and 23. Figure 21 is a photomicrograph at approximately 100X magnification showing a cross section through the sensor installation in the sleeve area of Specimen 1B. Resin flow into the sleeve is evident. Although voids are evident between the resin and sleeve areas and even in the resin itself, the resin in the vicinity of the two wires is free of voids. Any change in capacitance should, therefore, be caused by a capacitance change in the resin such as the moisture content change in resin. However, in Figures 22 and 23, voids between the two wires are clearly evident. If moisture would therefore get between the two wires, the sensor would be measuring (at least along part of the sensor length) free moisture which would be expected to be a large capacitance.

The above supposition is further verified by an examination of the data in Table A-7. At 22 hours an extremely large increase in capacitance was noted, and it kept rising until the end of the absorption environment. During desorb it gradually decreased until a large jump at 23.25 hours, then a more gradual decrease until the end of desorb. This same condition was noted in the second cycle for Specimen 2A and for both cycles of Specimen 14A.

Prior to this microscopic examination, specimens of this Type I configuration were exposed to two other environmental conditions. These two conditions were 120°F/50% RH Absorb with 120°F/0% RH Desorb and RT/50% RH Absorb with RT/0% RH Desorb. These two conditions are discussed in the next two paragraphs.

2.2.1.2 3-Ply Specimens Exposed to 120°F/50% RH Absorb and 120°F/0% RH Desorb -

Specimens 3A, 8B, and 15B were exposed to the environmental conditions of 120°F/50% RH Absorb and 120°F/0% RH Desorb. The tabulated weight, capacitance, and time data are shown in Tables A-11 through A-18. Figure 24 shows the average moisture content versus the percent capacitance change for Specimens 3A and 8B, and Figure 25 shows the local moisture content versus percent capacitance change for those two specimens. As shown in Tables A-11, A-14, and A-17, an attempt was made to turn the

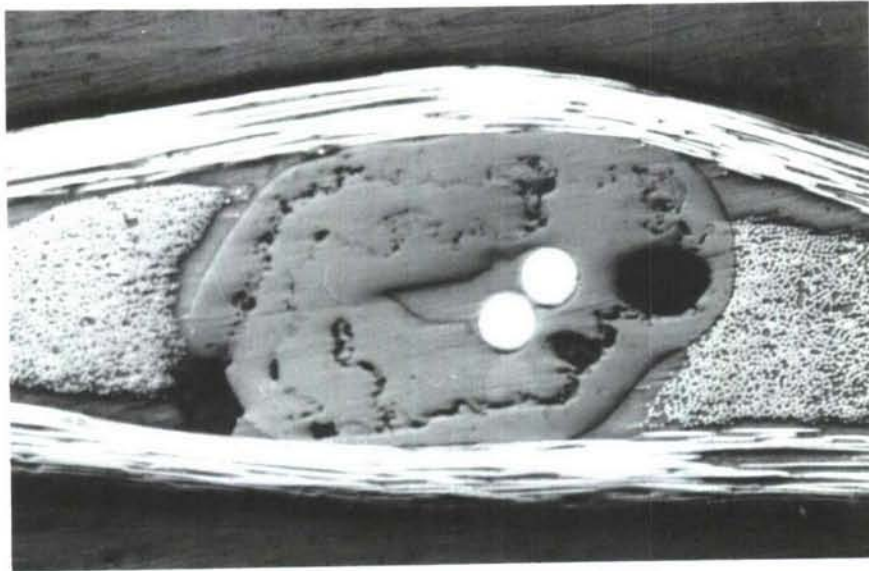

Figure 21. Cross Section Through Sleeve Area of Specimen 1B

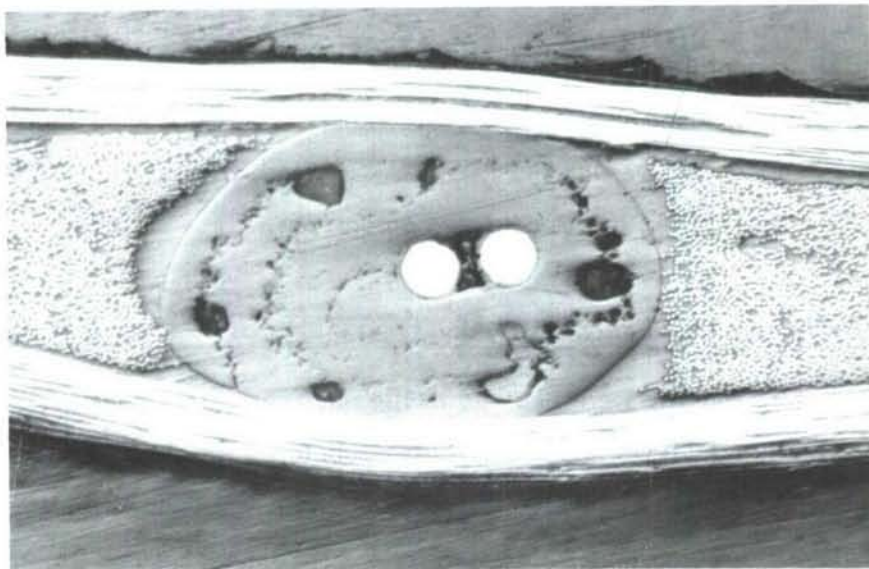

Figure 22. Cross Section Through Sleeve Area of Specimen 2A

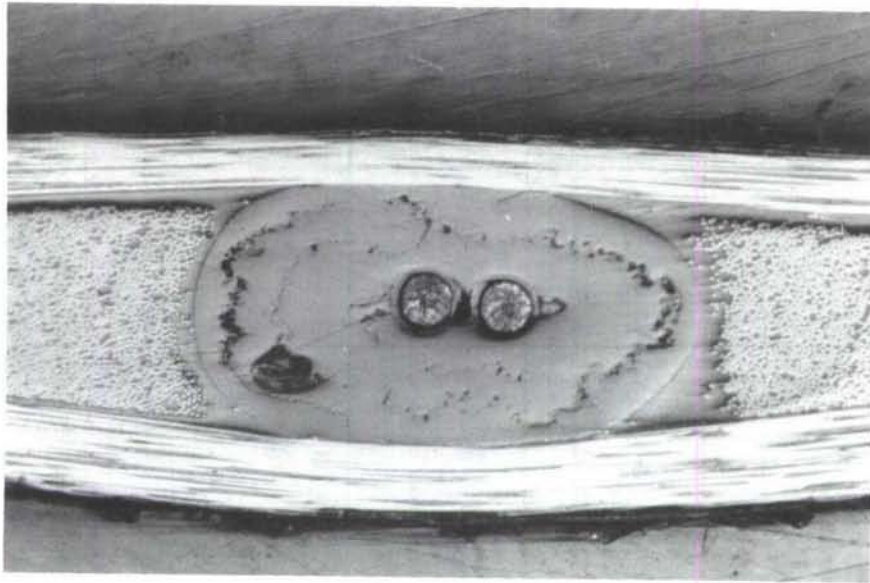

Figure 23. Cross Section Through Sleeve Area of Specimen 14A

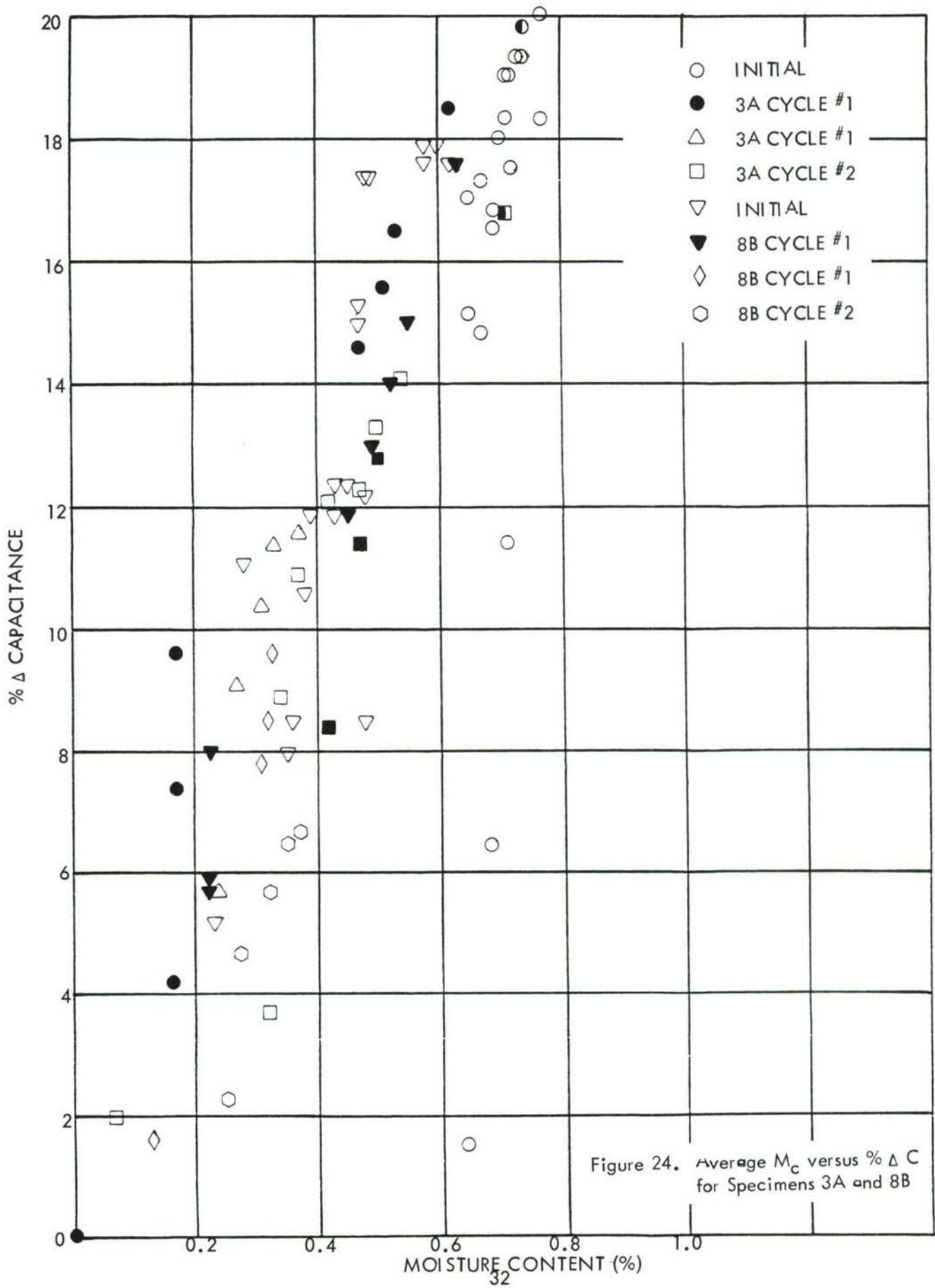
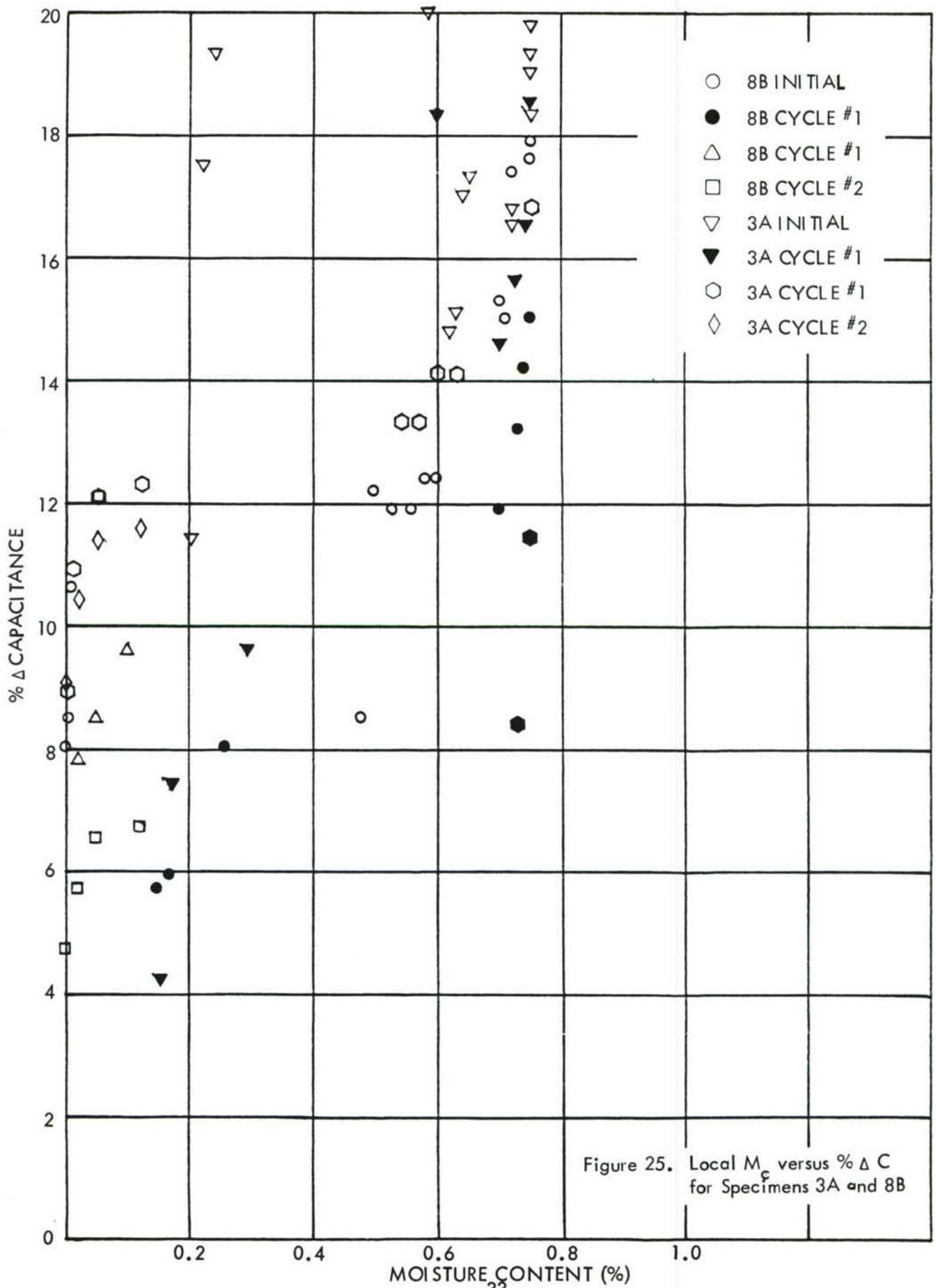

Figure 24. Average M_c versus % ΔC for Specimens 3A and 8B



environmental fan off during the reading times. This caused erratic weight and capacitance data and, therefore, the data is not plotted on the capacitance/moisture content correlation curves. Desorb Cycle Number 1 was started after this time period; then after completion of Desorb #1, Absorb #1 was started. As noted in Table A-17, the leads from Specimen 15B broke during the initial absorb cycle and also was not plotted on the capacitance/moisture correlation curves.

As shown in Tables A-12, A-15, and A-18, the environmental chamber condenser fan broke after 6.25 hours of the first absorb cycle. These specimens were placed in the desorb chamber and then started into the Absorb Number 2 cycle when the condenser fan was fixed.

In spite of the equipment difficulties experienced during this environmental condition testing, good capacitance/moisture content correlation was obtained as shown in Figures 24 and 25.

2.2.1.3 3-Ply Specimens Exposed to RT/50% RH Absorb and RT/0% RH Desorb -

Tables A-19, A-20, and A-21 show the tabulated weight, capacitance, and time data for Specimens 4B, 8A, and 8B exposed to one cycle of the environmental conditions of RT/50% RH Absorb and RT/0% RH Desorb. Figure 26 shows the average moisture content versus the percent capacitance change for all three specimens. Figure 27 shows the local moisture content versus the percent capacitance change for Specimen 4B, and Figure 28 shows the local moisture content versus the percent capacitance change for Specimens 8A and 8B. From the three figures, it is obvious that data for Specimen 4B shows abnormally high capacitance readings indicating a condition similar to that described for Specimens 2A and 14A in paragraph 2.2.1.1 above. The moisture content/capacitance correlation for Specimens 8A and 8B is fair.

2.2.1.4 3-Ply Specimens Exposed to 160°F/75% RH Absorb and 160°F/20% RH Desorb -

Tables A-22 through A-27 show the tabulated weight, capacitance, and time data for Specimens 13, 17, and 21 exposed to two cycles of 160°F/75% RH Absorb and 160°F/20% RH Desorb. Figure 29 shows the average moisture content versus the percent

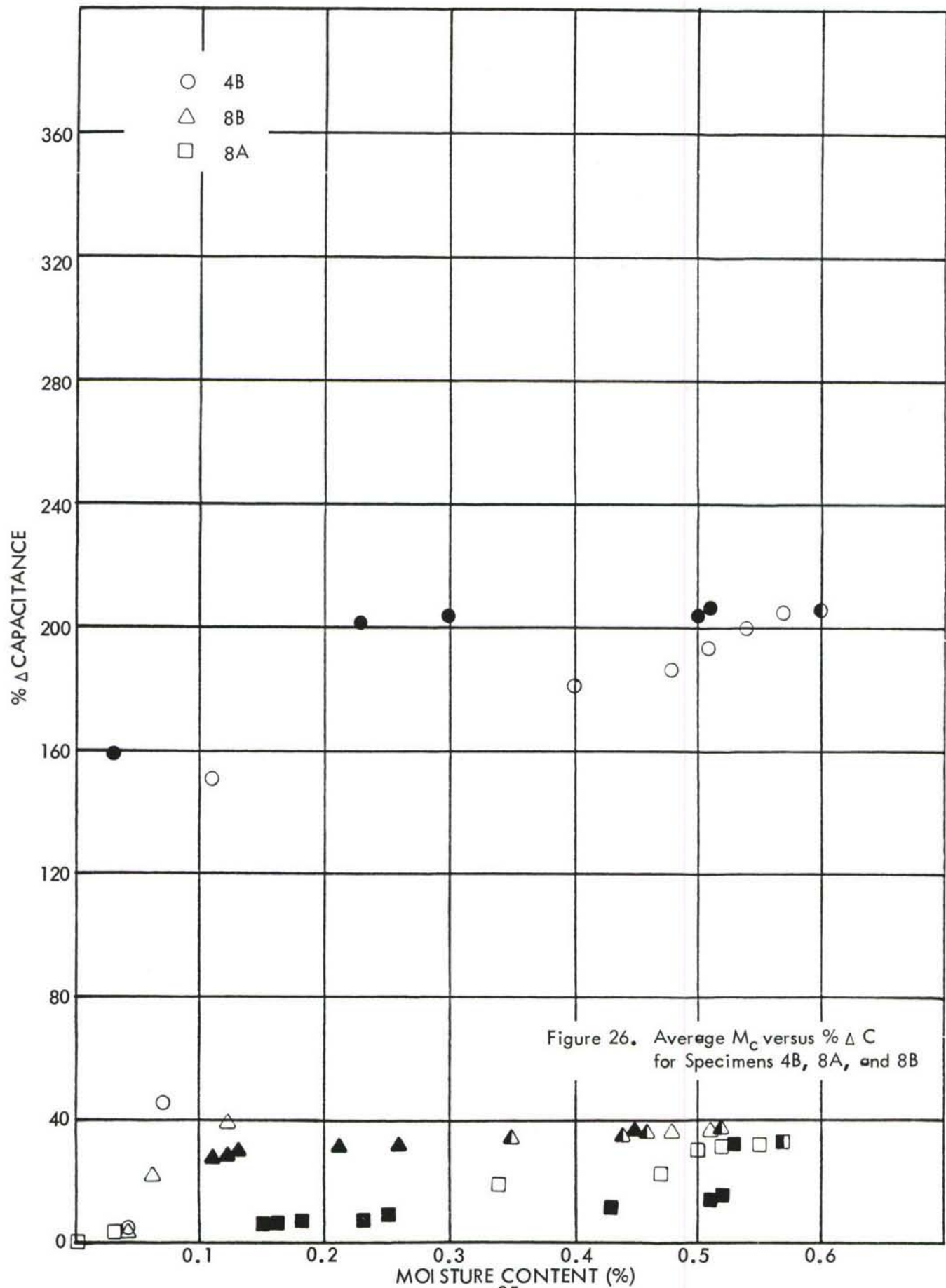

Figure 26. Average M_c versus % Δ C for Specimens 4B, 8A, and 8B

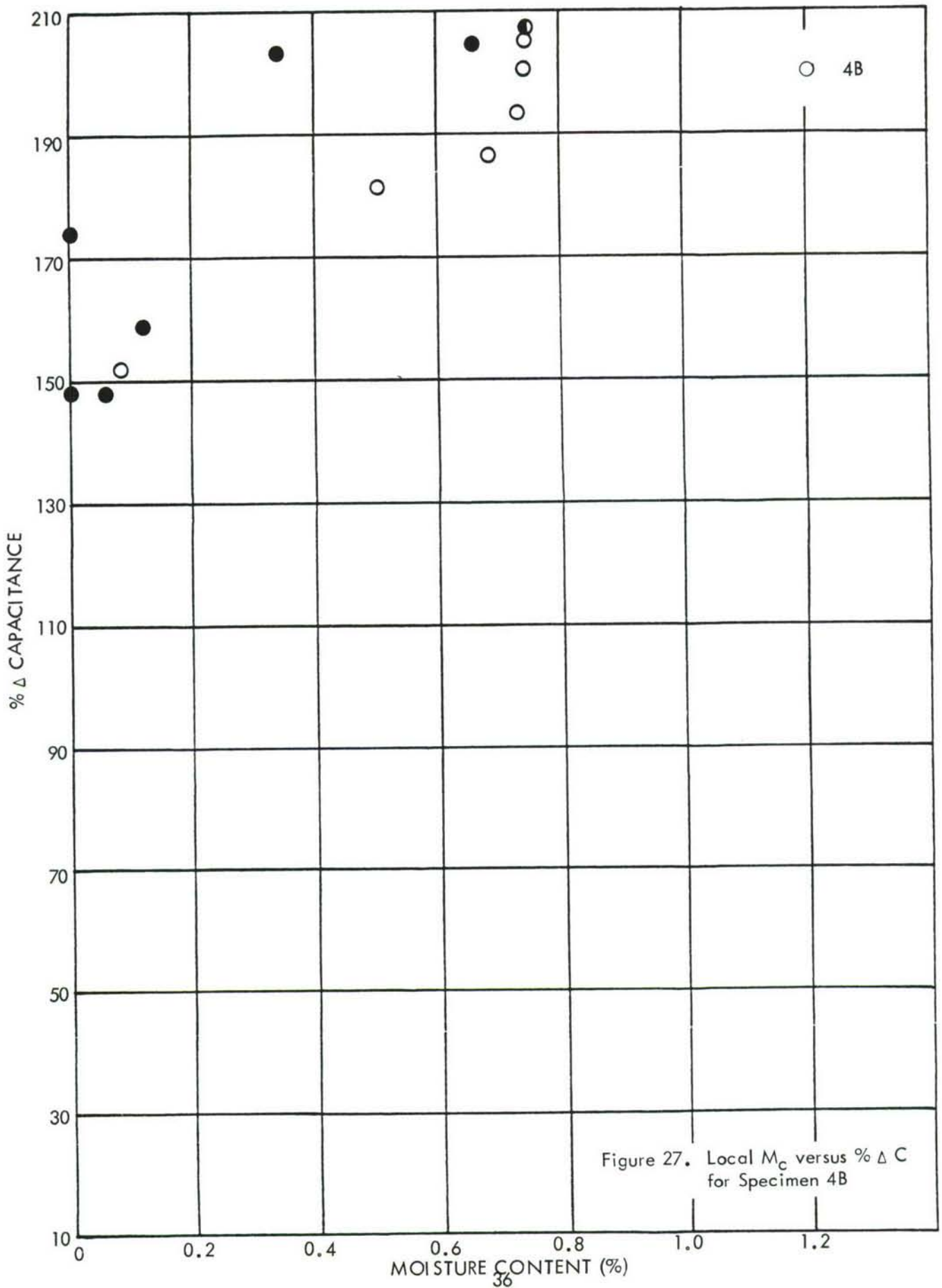

Figure 27. Local M_c versus % ΔC for Specimen 4B

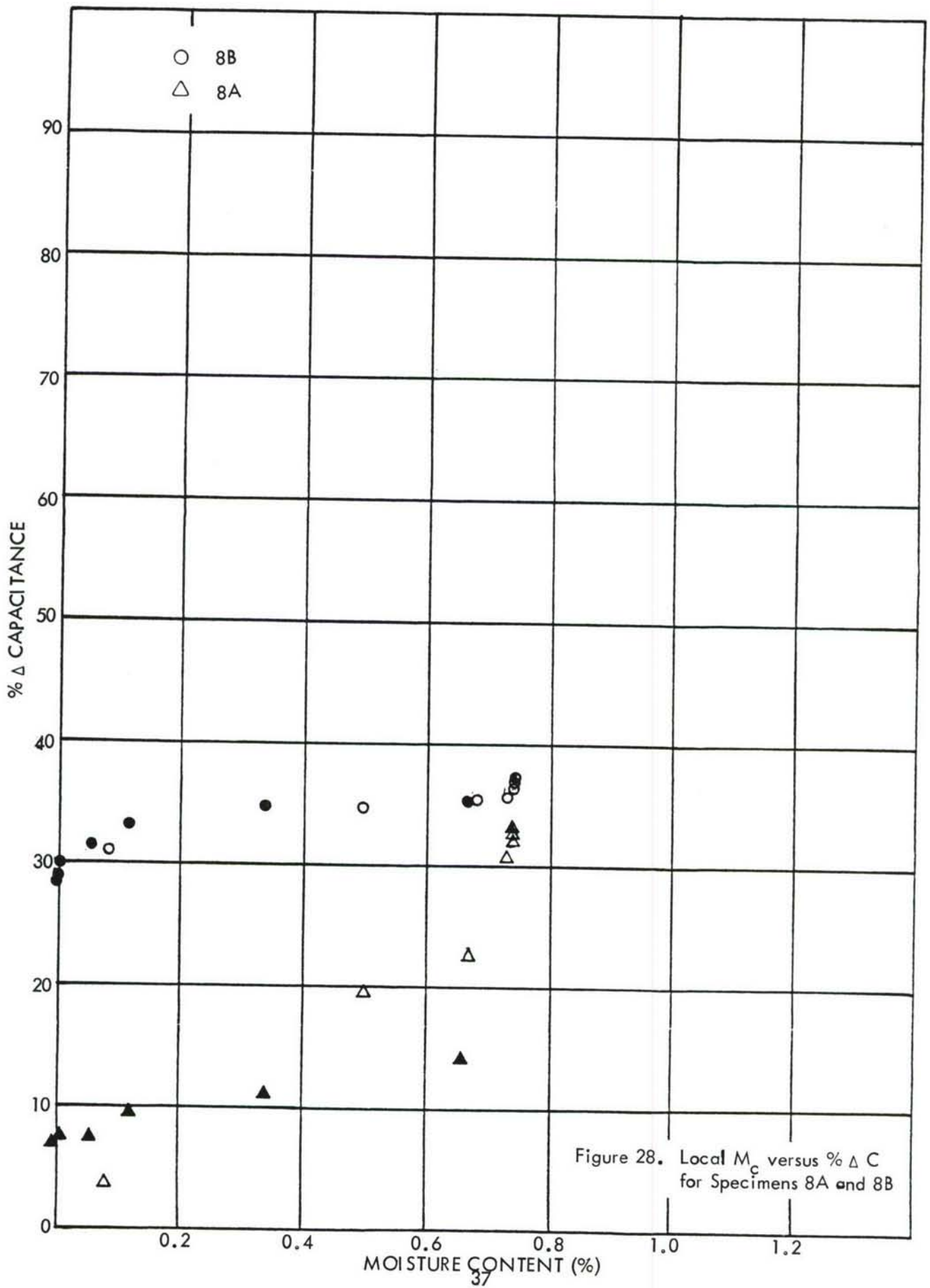

Figure 28. Local M_c versus % ΔC for Specimens 8A and 8B

capacitance change for all three specimens. Figure 30 shows the local moisture content versus the percent capacitance change for Specimens 13 and 17, and Figure 31 shows the local moisture content versus the percent capacitance change for Specimen 21. Although the capacitance change versus local moisture content data is very erratic for Specimens 13 and 17 during absorb, it is much better during desorb. The local moisture content data versus percent capacitance change is fair for Specimen 21 except for the first desorb cycle.

This series is the Type II specimens. Since the capacitance leads were encased in Mylar shrink tubing and from the long length of lead to the pins with Teflon shrink tube, some of the erratic readings may be accounted for by moisture condensing on the leads and specimens from the environmental port opening during the data taking and from moisture entry inside the shrink tube through the cracked tubes or improper seal at the tube ends.

2.2.1.5 3-Ply Specimens Exposed to 160°F/98% RH Absorb and 160°F/0% RH Desorb -

The weight, capacitance, and time data for Specimens 29 and 31 exposed to two cycles of 160°F/98% RH Absorb and 160°F/0% RH Desorb are tabulated in Tables A-28 through A-31. These two specimens are the Type III specimens as discussed in paragraph 2.1.2.2. Figure 32 shows the average moisture content versus the percent capacitance change for both specimens during the desorb portion of the two cycles only. Figure 33 shows the local moisture content versus the percent capacitance change during desorb of the two specimens.

As noted in Tables A-28 through A-31, abnormally high weight readings were observed during the absorb part of both cycles for both specimens indicating an extremely high moisture content. The capacitance readings, although somewhat high, were better behaved than the weight indications. However, Specimen 29 had high enough weight reading to go off scale early during absorb cycle Number 2 and returned only after 25 hours of the second desorb cycle indicating a free moisture capacitance measurement. This free moisture may be even inside the tube. The excessive high weights were caused by excessive moisture condensation on the specimens and on the sensor leads; and, as indicated above, free moisture may possibly exist inside the aluminum tube or Teflon shrink tube.

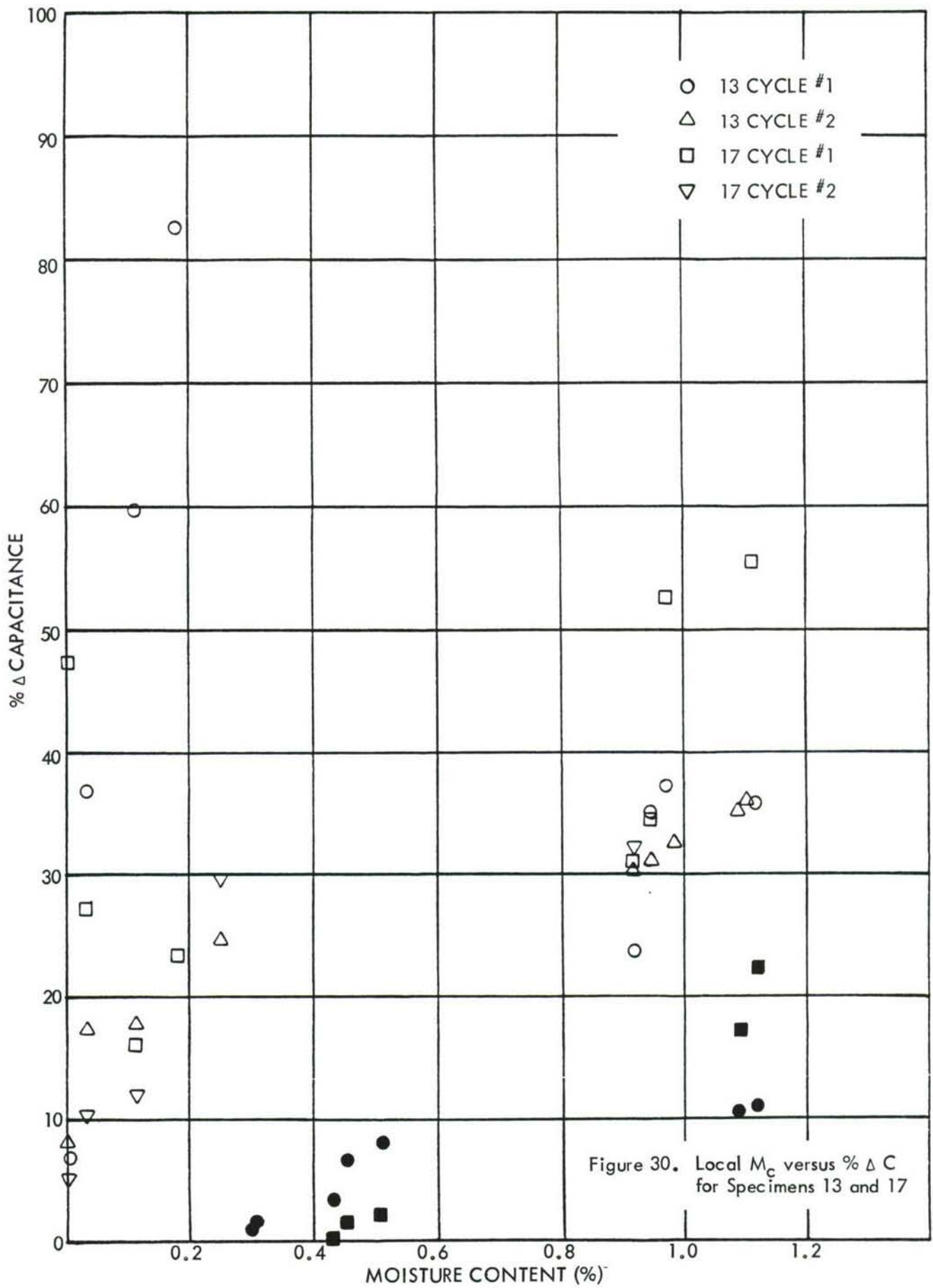
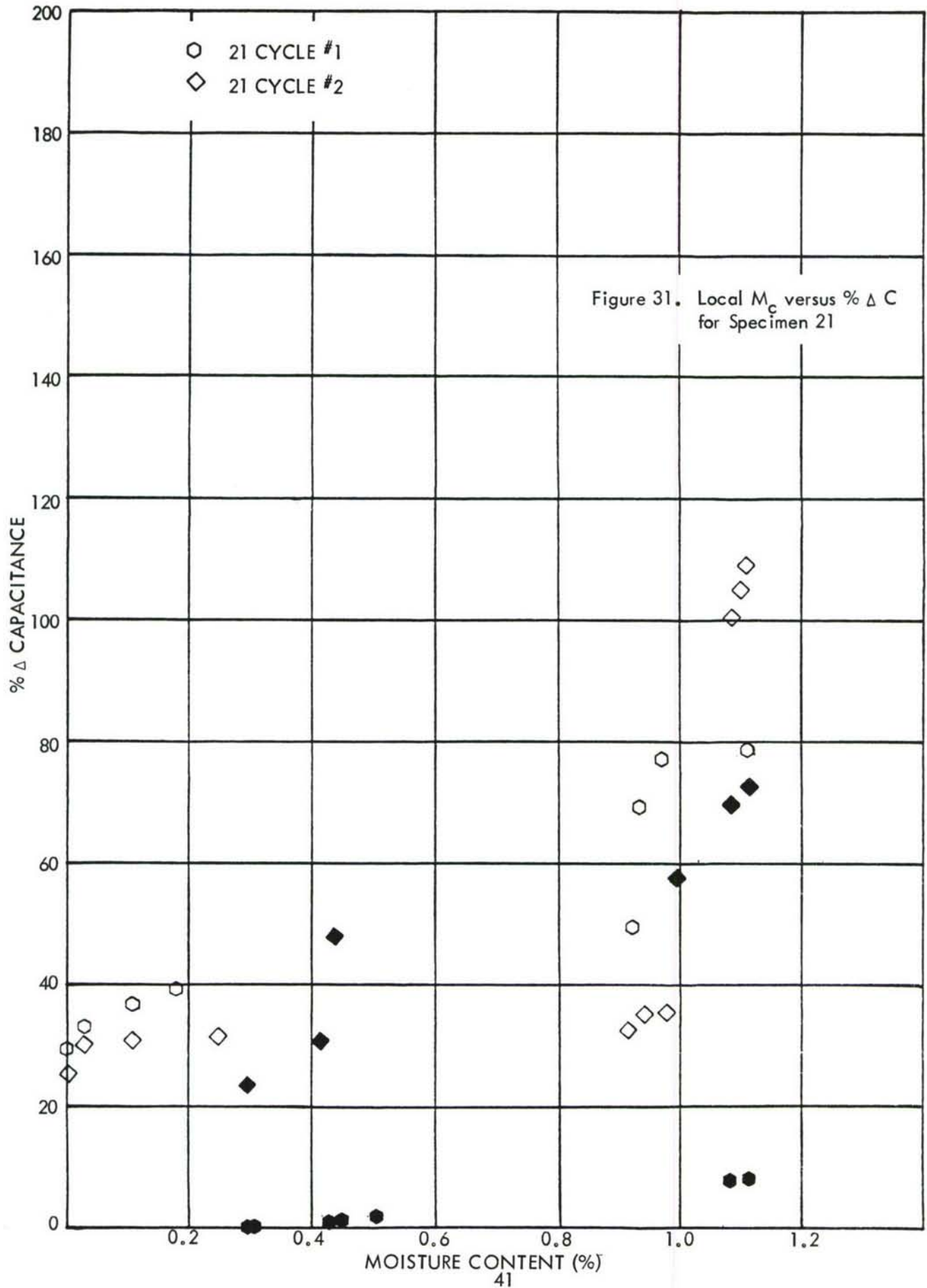

Figure 30. Local M_c versus % ΔC for Specimens 13 and 17



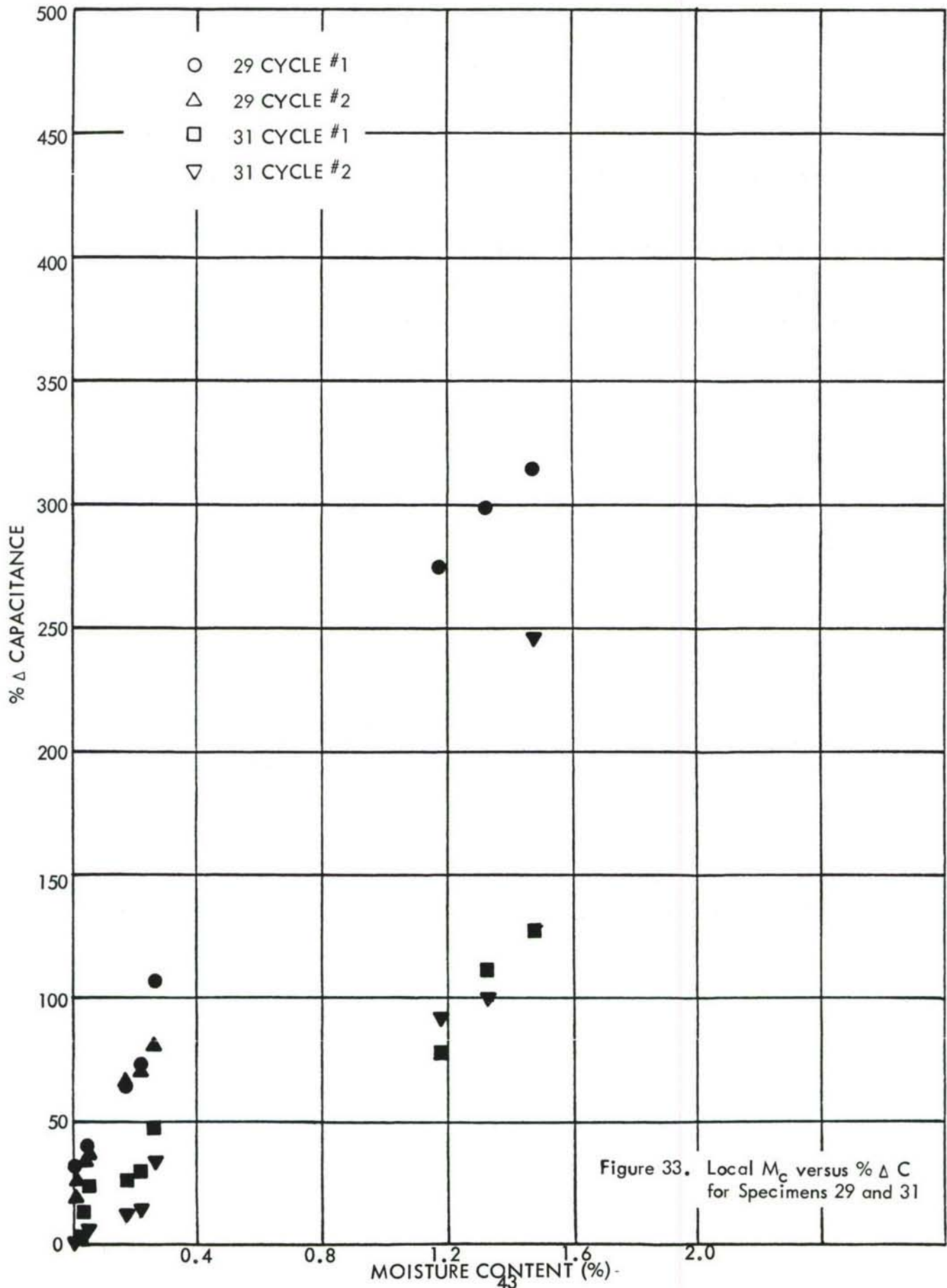

Figure 33. Local M_c versus % Δ C for Specimens 29 and 31

2.2.1.6 3-Ply Specimens Exposed to 160°F/98% RH Absorb and 160°F/50% RH Desorb -

The weight, capacitance, and time data for Type III Specimens 32 and 33 exposed to one cycle of 160°F/98% RH Absorb and 160°F/50% RH Desorb are tabulated in Tables A-32 and A-33. Figure 34 shows the average moisture content versus the percent capacitance change for only part of the desorb cycle, and Figure 35 shows the local moisture content versus percent capacitance change for those same points. As noted on the tables, the air circulation blower motor and associated assembly on the humidity chamber malfunctioned at the end of the Absorb Cycle Number 1. Since it was not possible to attain the temperature/humidity conditions of 160°F/50% RH required for desorption, these specimens were maintained at ambient conditions while the humidity chamber was repaired. The specimens were then exposed to a second absorb cycle prior to desorption after the repair was completed. The moisture content during the absorption portion was erratically high for Specimens 32 and 33, as was the case for Specimens 29 and 31 previously described. In addition, the capacitance for Specimen 32 was both high and erratic during both absorb and desorb. This again indicates free moisture as previously described. Though erratic, the capacitance readings of Specimen 33 behaved in a more normal manner, although the final moisture content (after desorb) was as expected for Specimen 32 and lower than expected for Specimen 33.

2.2.1.7 3-Ply Specimens Exposed to 160°F/50% RH Absorb and 160°F/0% RH Desorb -

The weight, capacitance, and time data for Type III Specimens 30 and 35 exposed to one cycle of 160°F/50% RH Absorb and 160°F/0% RH Desorb are shown in Tables A-34 and A-35. Figure 36 shows the average moisture content versus the percent capacitance change, and Figure 37 shows the local moisture content versus the percent capacitance change for the two specimens during both absorb and desorb. Since this environmental condition was much milder than the two previously discussed conditions, both the moisture content and capacitance change behaved more nearly as expected. Both the moisture content and capacitance was somewhat higher than expected.

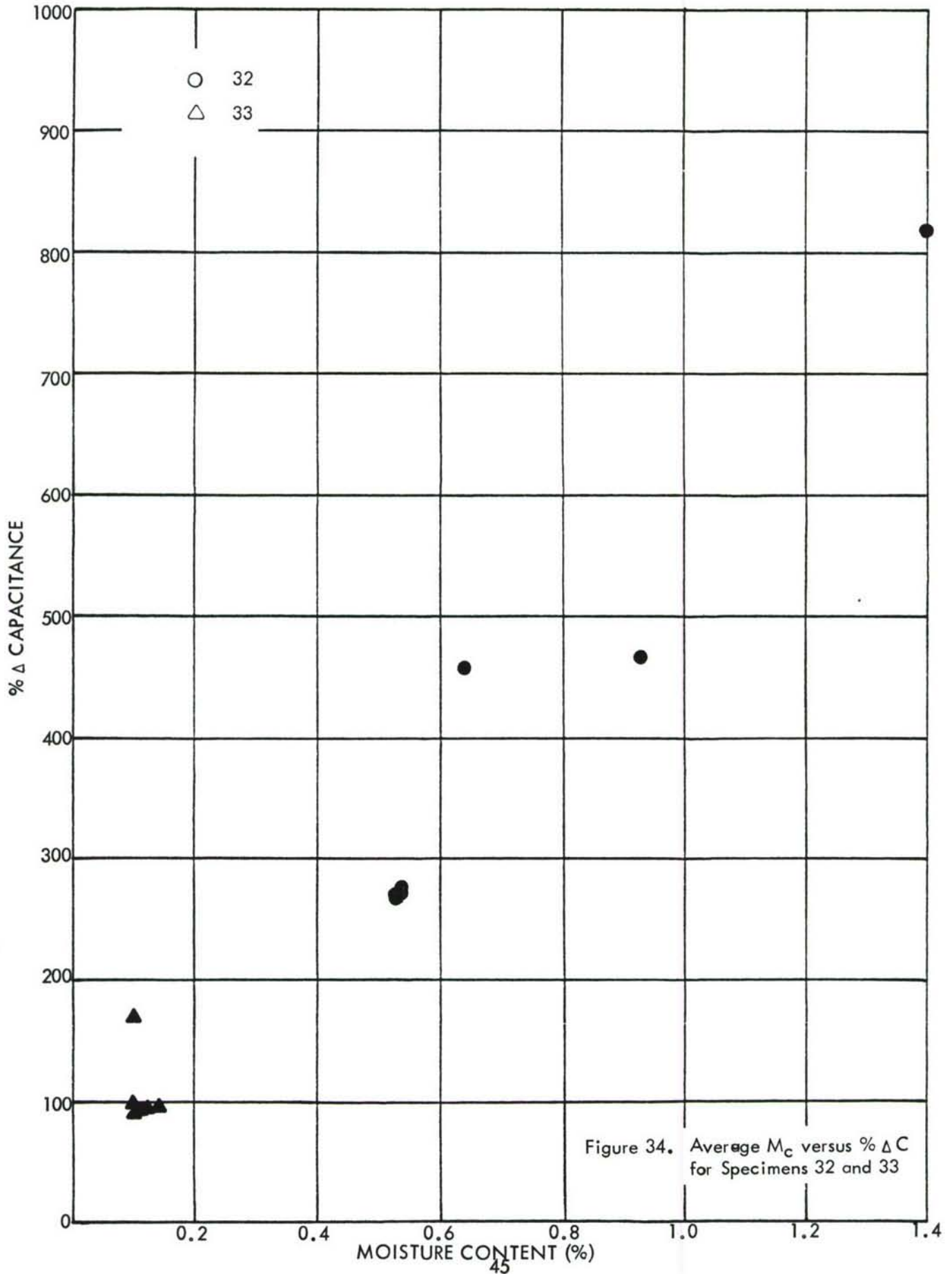

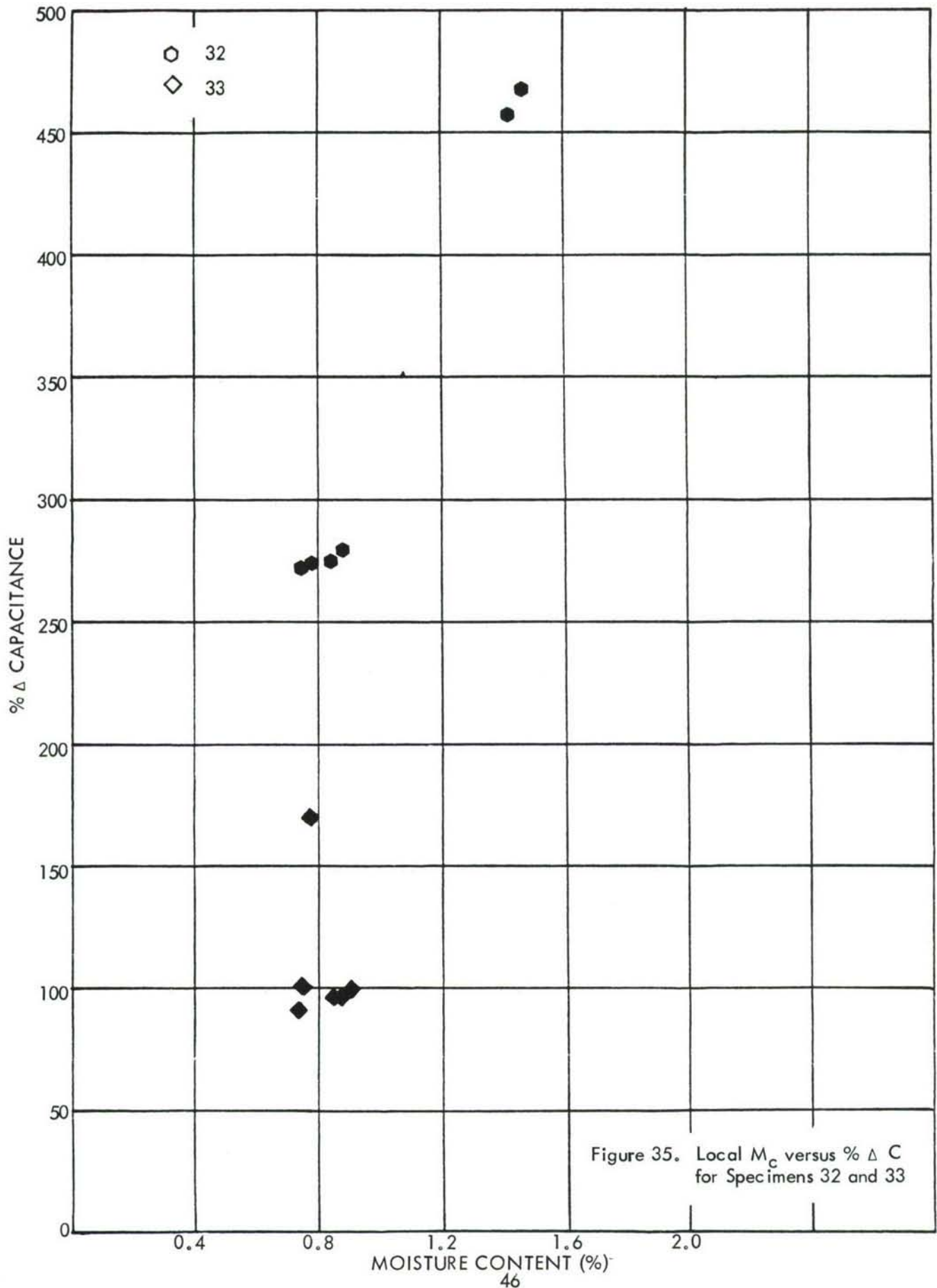

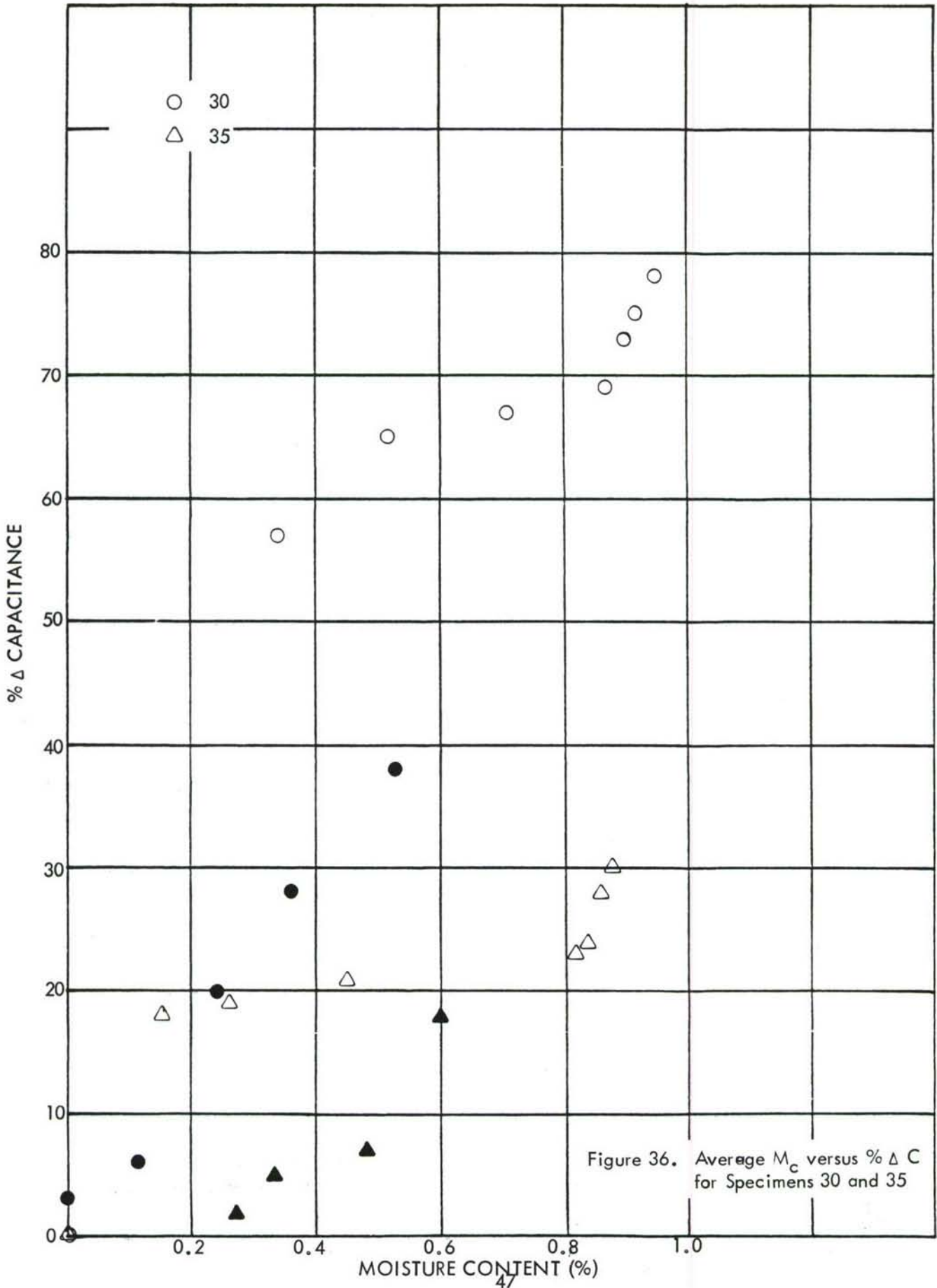
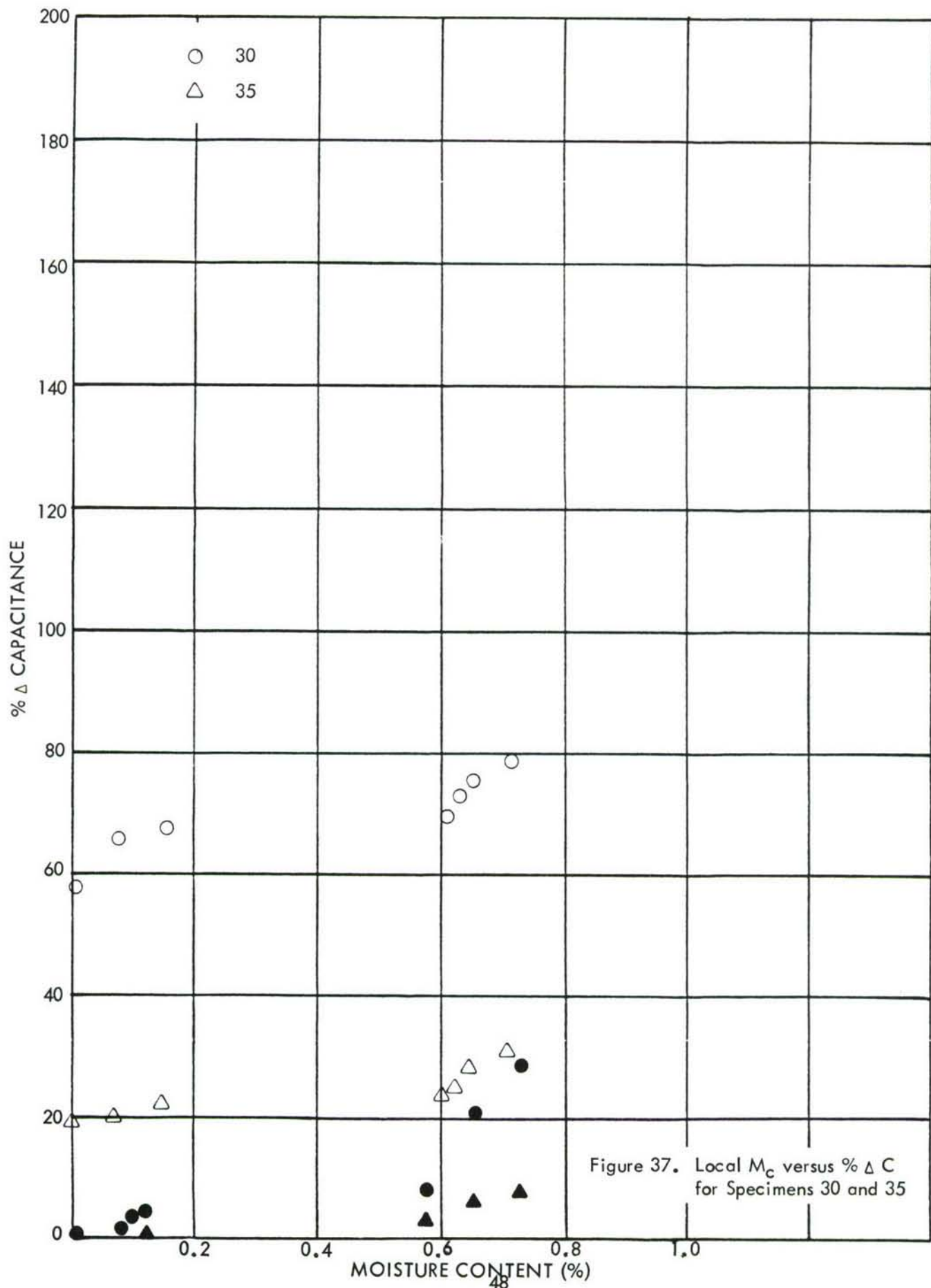

Figure 36. Average M_c versus % Δ C for Specimens 30 and 35



2.2.1.8 3-Ply Specimens Exposed to RT/93% RH Absorb and RT/0% RH Desorb -

Specimens AFD, BFD, and CFD were exposed for two cycles to the environmental conditions of RT/93% RH during absorb and RT/0% RH during desorb. The absorption environment for these specimens was created by placing a solution of 500 grams of ammonium dihydrogen phosphate and 250 ml of water in the bottom of a desiccator and allowing this salt solution to settle for 24 hours prior to placing the specimens above the salt solution. The desorption environment was created by replacing the salt solution with a desiccant. These three specimens were Type IV as discussed in Section 2.1.2 above. Each specimen was 4 inches by 4 inches and contained two sensors in the middle ply as shown in the X-ray photograph of Figure 38.

The weight, capacitance, and time data for the three specimens exposed to two cycles of this environment is tabulated in Tables A-36 through A-41. The average moisture content versus percent capacitance change for the two sensors of each of the three specimens for Cycle Number 1 is shown in Figure 39. Cycle Number 2 plots essentially on top of Cycle Number 1 and, therefore, was not plotted. Figure 40 shows the local moisture content versus percent capacitance change for one of the sensors of Specimen AFD for the two cycles. The data for the other sensor of Specimen AFD and for the other two specimens was very nearly the same and therefore was not plotted. As seen from Figures 39 and 40, a good moisture content/capacitance correlation was obtained for their environmental test condition.

2.2.1.9 3-Ply Specimens Exposed to RT/75% RH Absorb and RT/0% RH Desorb -

Specimens DFD, EFD, and FFD were exposed for two cycles to the environmental conditions of RT/75% RH absorb and RT/0% RH desorb. This absorptive environment was created by placing a solution of 500 grams of sodium chloride and 250 ml of water in the bottom of a desiccator and allowing this salt solution to settle for 24 hours prior to placing the specimens above the salt solution. As stated in paragraph 2.2.1.8, the desorption environment was created by replacing the salt solution with a desiccant. These three specimens were also Type IV as were the three specimens discussed in paragraph 2.2.1.8 above.

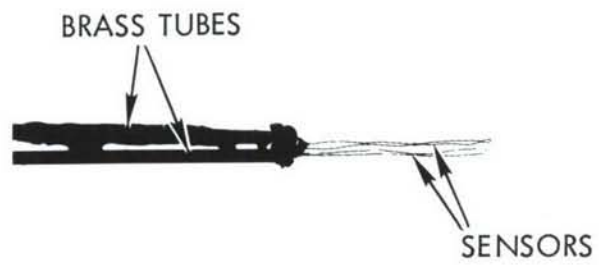

Figure 38. X-ray Photograph of Type IV Specimens

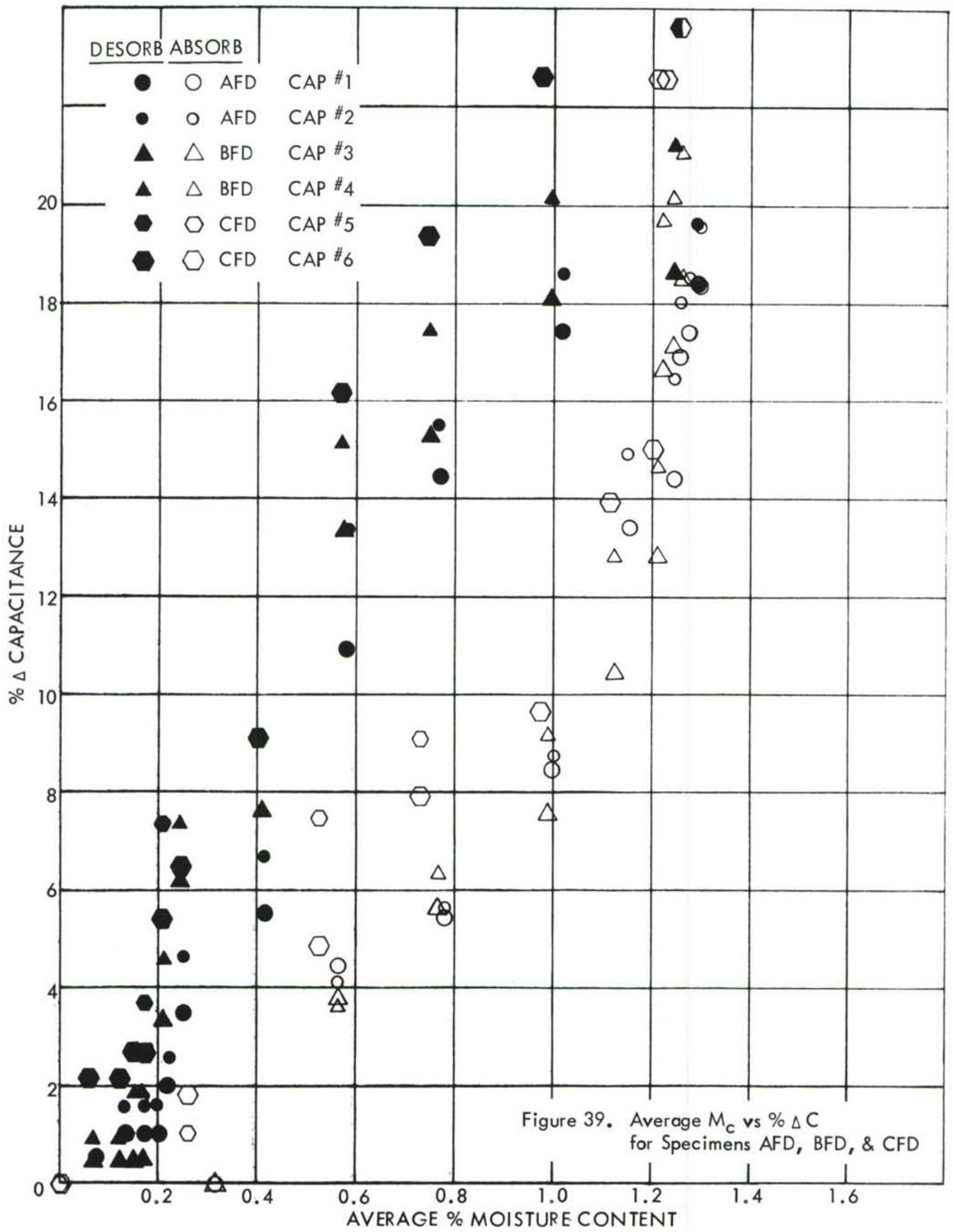
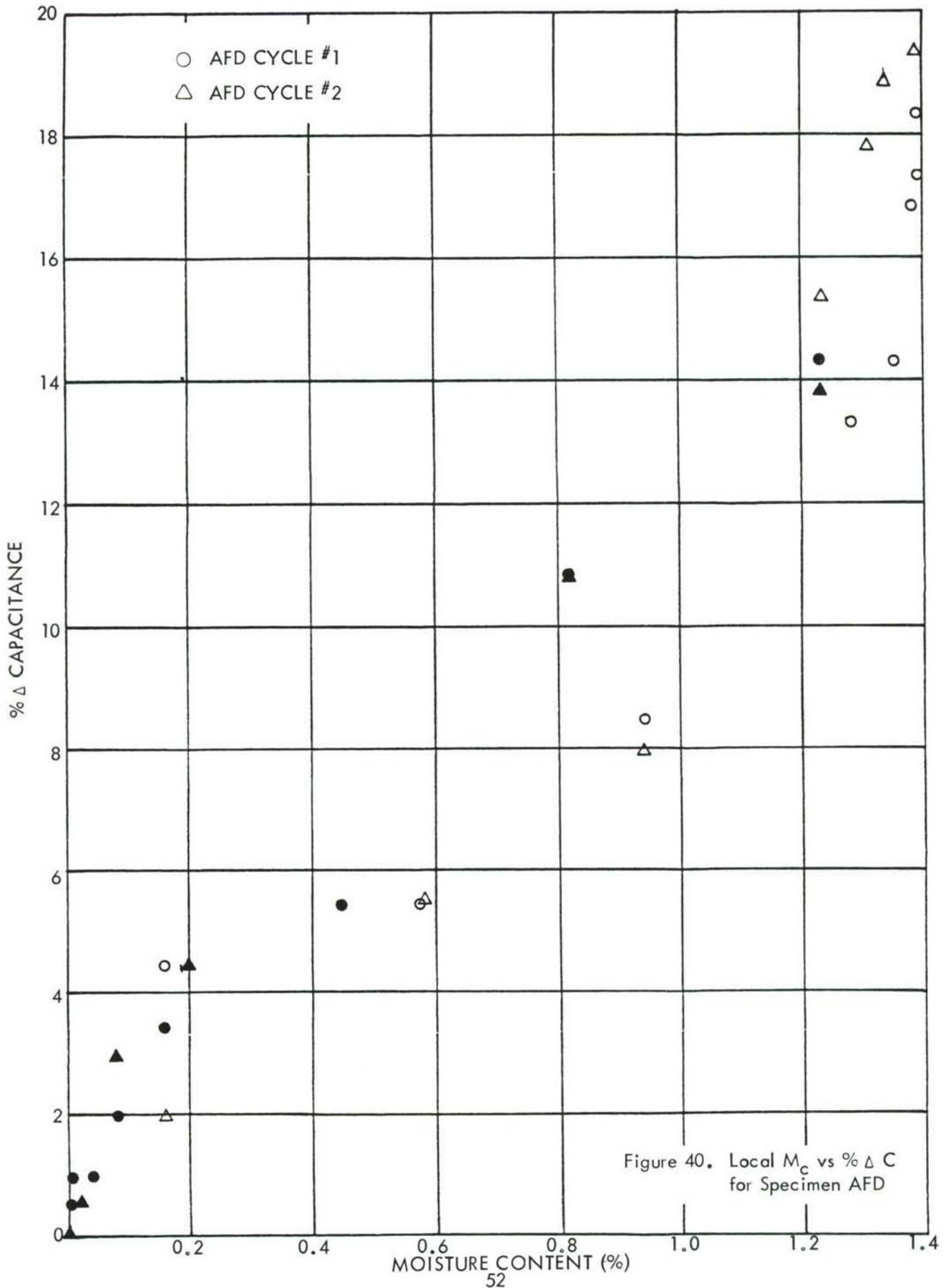

Figure 39. Average M_c vs % ΔC for Specimens AFD, BFD, & CFD



The weight, capacitance, and time data for the three specimens exposed to two cycles of this environment is tabulated in Tables A-42 through A-47. The average moisture content versus percent capacitance change for the two sensors of each of the three specimens for Cycle Number 1 is shown in Figure 41. Cycle Number 2 plots essentially on top of Cycle Number 1 and, therefore, was not plotted. Figure 42 shows the local moisture content versus percent capacitance change for both cycles of one of the sensors from DFD as typical of all three specimens exposed to this environment. As evident from Figures 41 and 42, good correlation between moisture content and capacitance change was obtained for this environmental test condition.

2.2.1.10 3-Ply Specimens Exposed to 120°F/75% RH Absorb and 120°F/0% Desorb - Specimens GFD, HFD, and IFD were exposed for two cycles to the environmental conditions of 120°F/75% RH Absorb and 120°F/0% RH Desorb. The environmental test equipment described in paragraph 2.1.1.3 was used for these specimens as was the case for all the previously discussed 3-ply specimens except those discussed in paragraphs 2.2.1.8 and 2.2.1.9. However, because of the moisture condensation problems experienced with the previously discussed 3-ply specimens during the data taking times, the environment inside the environmental chamber was changed to an environment below the room temperature dew point prior to and during the weight and capacitance measurement periods. This procedure was worked out experimentally with the help of the Blue M Company and was previously used successfully on the Task II 13-ply specimens discussed in Section 2.2.2 below.

The weight, capacitance, and time data for the three specimens exposed to two cycles of this environment is tabulated in Tables A-48 through A-53. The average moisture content versus percent capacitance change for the average capacitance of the two sensors of each of the three specimens for both cycles is shown in Figure 43. As seen in Figure 43, Specimens HFD and IFD showed a higher moisture content with essentially the same percent capacitance change as Specimen GFD. However, during the second cycle, all three specimens behaved essentially the same. It is believed that this excessive moisture content was caused by experimentation of the environmental fan being left on or turned off during the data taking time periods as shown in Tables A-48,

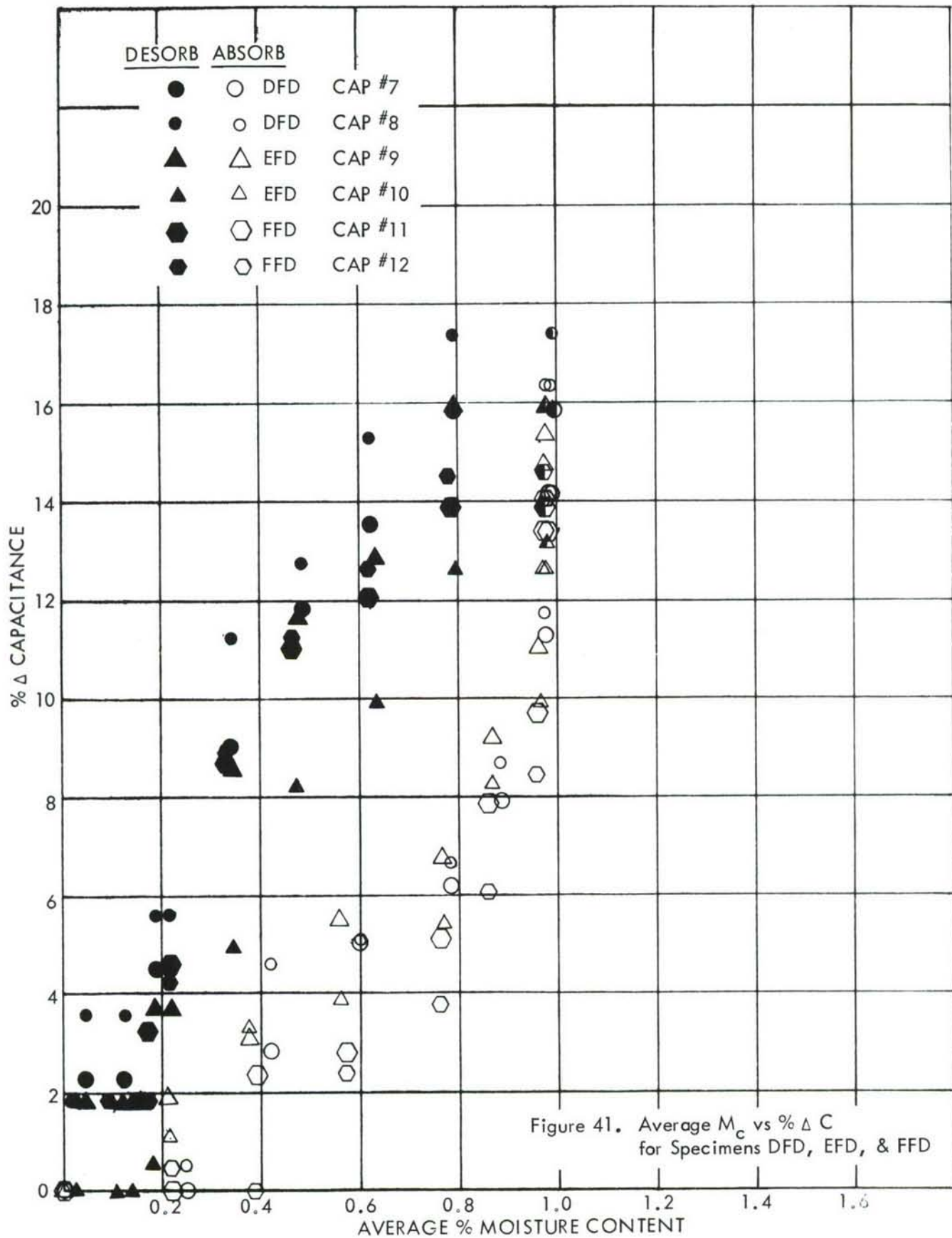

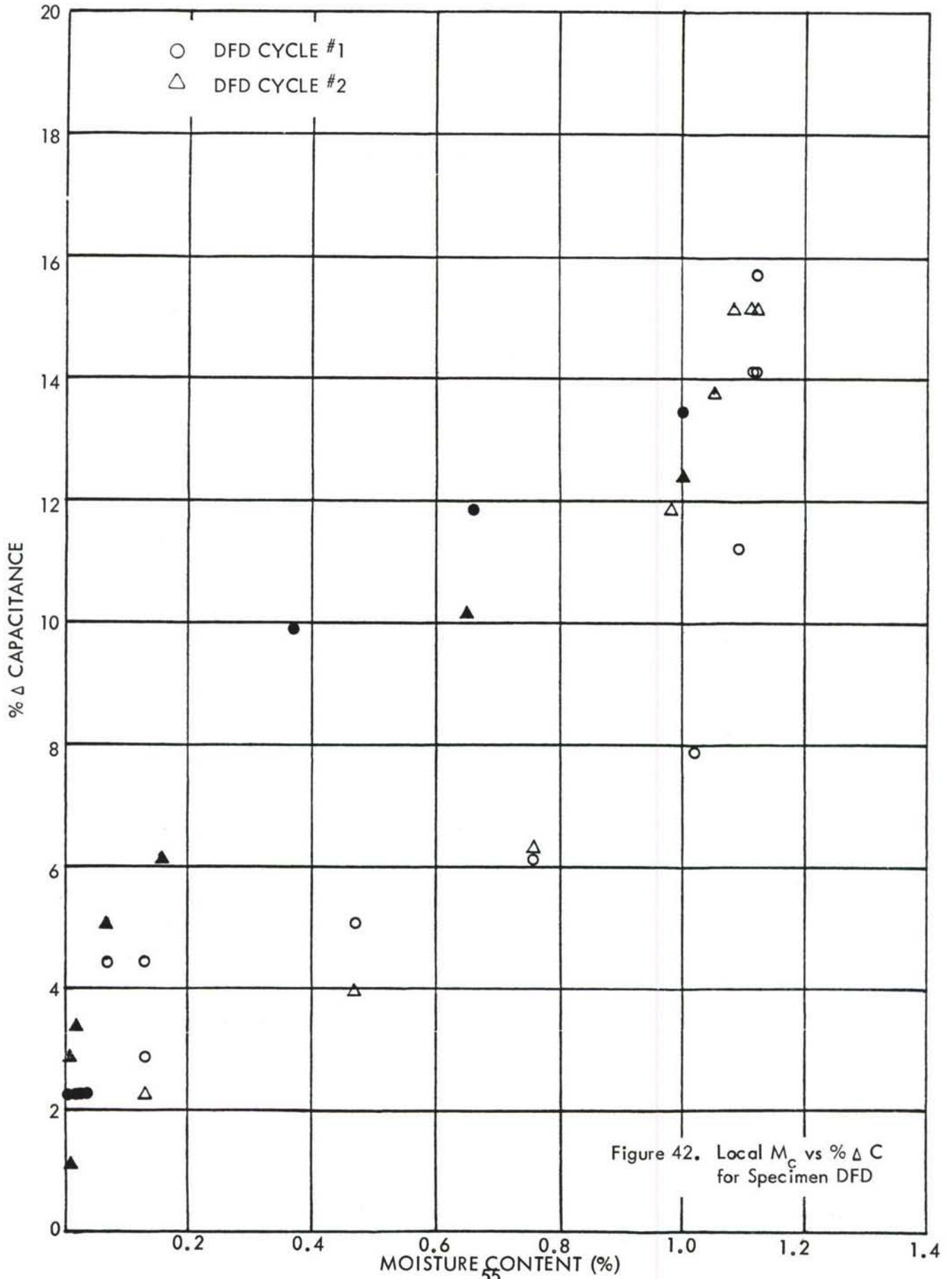

Figure 42. Local M_c vs % ΔC for Specimen DFD

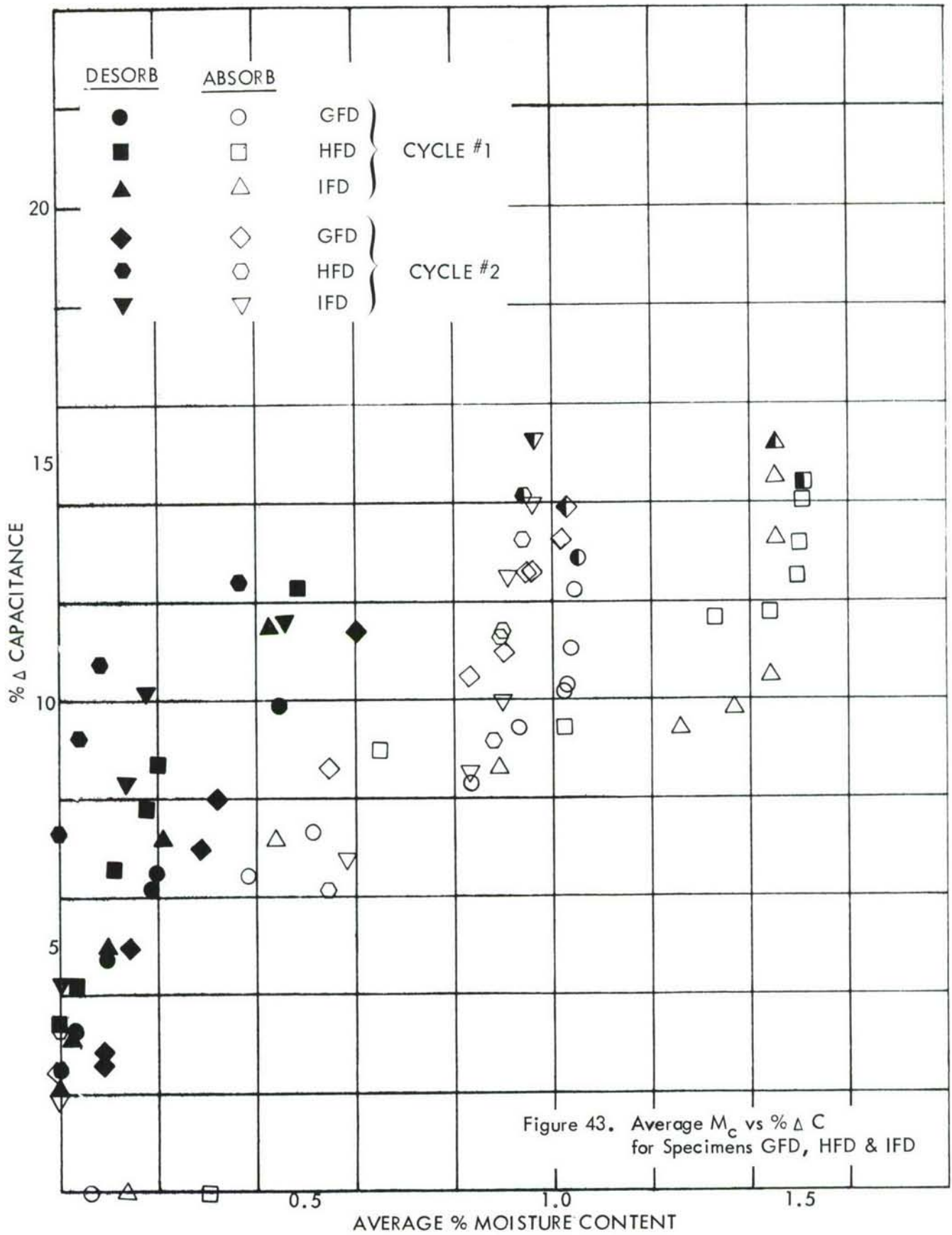

Figure 43. Average M_c vs % ΔC for Specimens GFD, HFD & IFD

A-50, and A-52. It was determined that the more consistent data was observed with the environmental fan turned off.

Figure 44 shows the local moisture content versus percent capacitance change for both cycles of one of the sensors from Specimen GFD as typical of all three specimens exposed to this environment. A good moisture content/capacitance correlation is shown in Figure 44, and this correlation is consistent with that shown in Figure 42. This indicates that the moisture content/capacitance correlation curve is more a function of percent relative humidity than of temperature, at least for room temperature and 120°F.

2.2.1.11 Moisture Content/Capacitance Correlation for Task I Specimens - The most consistent moisture content/capacitance data for the Task I specimens were demonstrated by the nine specimens AFD through IFD discussed in the three previous paragraphs, 2.2.1.8, 2.2.1.9 and 2.2.1.10. As seen in Figures 39, 41 and 43, two separate curves may be drawn through the data points, one for the data obtained during absorption and the other for the data obtained during desorption. However, if the average percent moisture content were defined as the percent moisture gain during absorption and the percent moisture loss during desorption, the test data would collapse into one curve as seen in Figures 45 through 53. The continuous curve is the same in each of the nine figures, and the data points represent the moisture content and capacitance observed for each specimen during two absorption and desorption cycles to their respective temperature and humidity environments.

2.2.2 Task II Test Results

The Task II specimens were the four Type III 13-ply Specimens A, B, C, and D with six sensors in each specimen as discussed in Section 2.1.2. Also discussed in that section was the sensor configuration, specimen configuration, sensor placement through the thickness, and specimen orientation. Figure 54 is an X-ray photograph of Specimen A which is typical of both Specimens A and B showing the sensor placement, sealant over the bleeder where the sensors emerge from the specimen, and installation of the aluminum tube on the specimen. Figure 55 is an X-ray photograph of Specimen D which is typical of both Specimens C and D showing the sensor placement, sealant over the

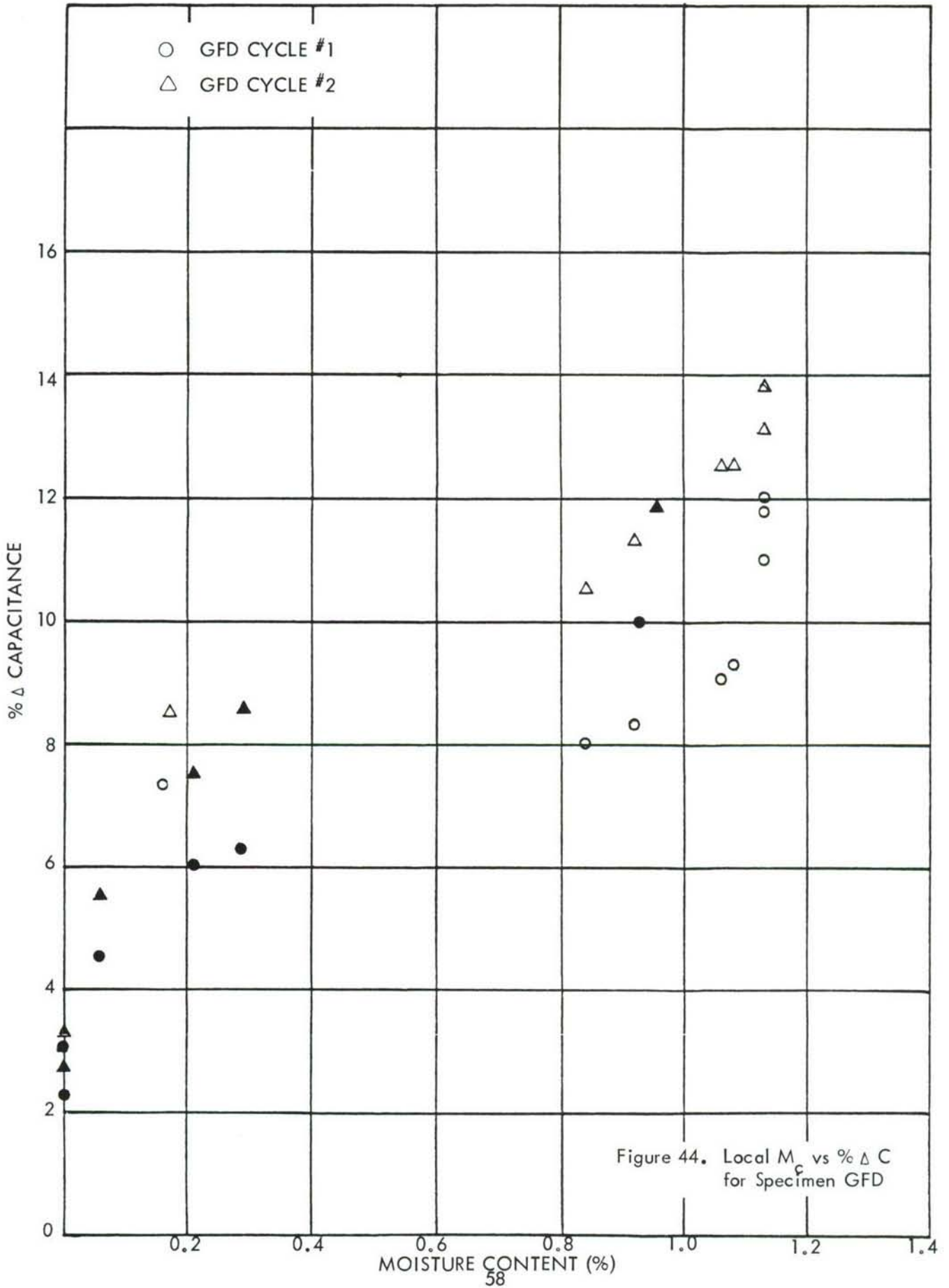

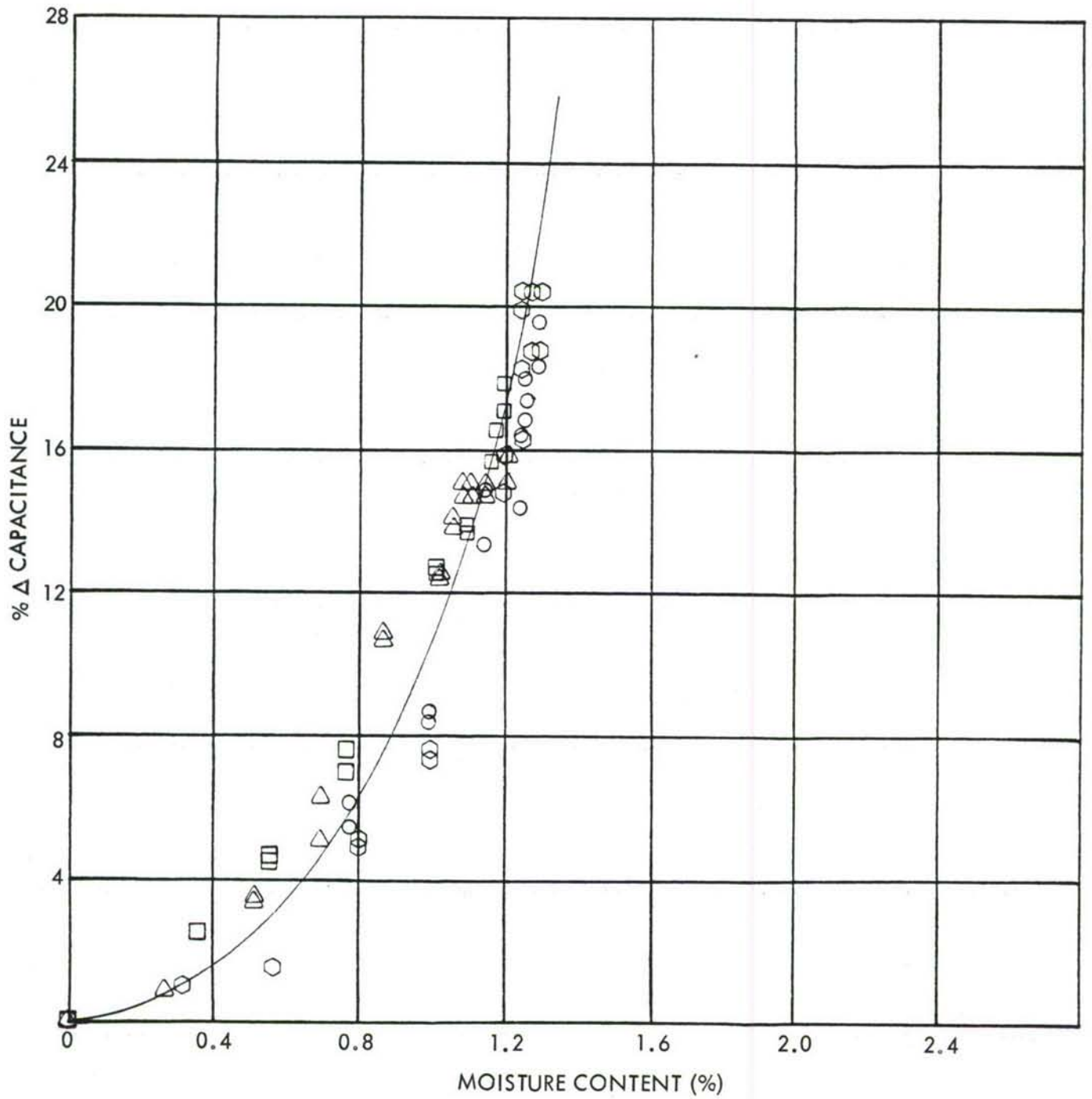

Figure 45. Moisture Content/Capacitance Correlation for Specimen AFD

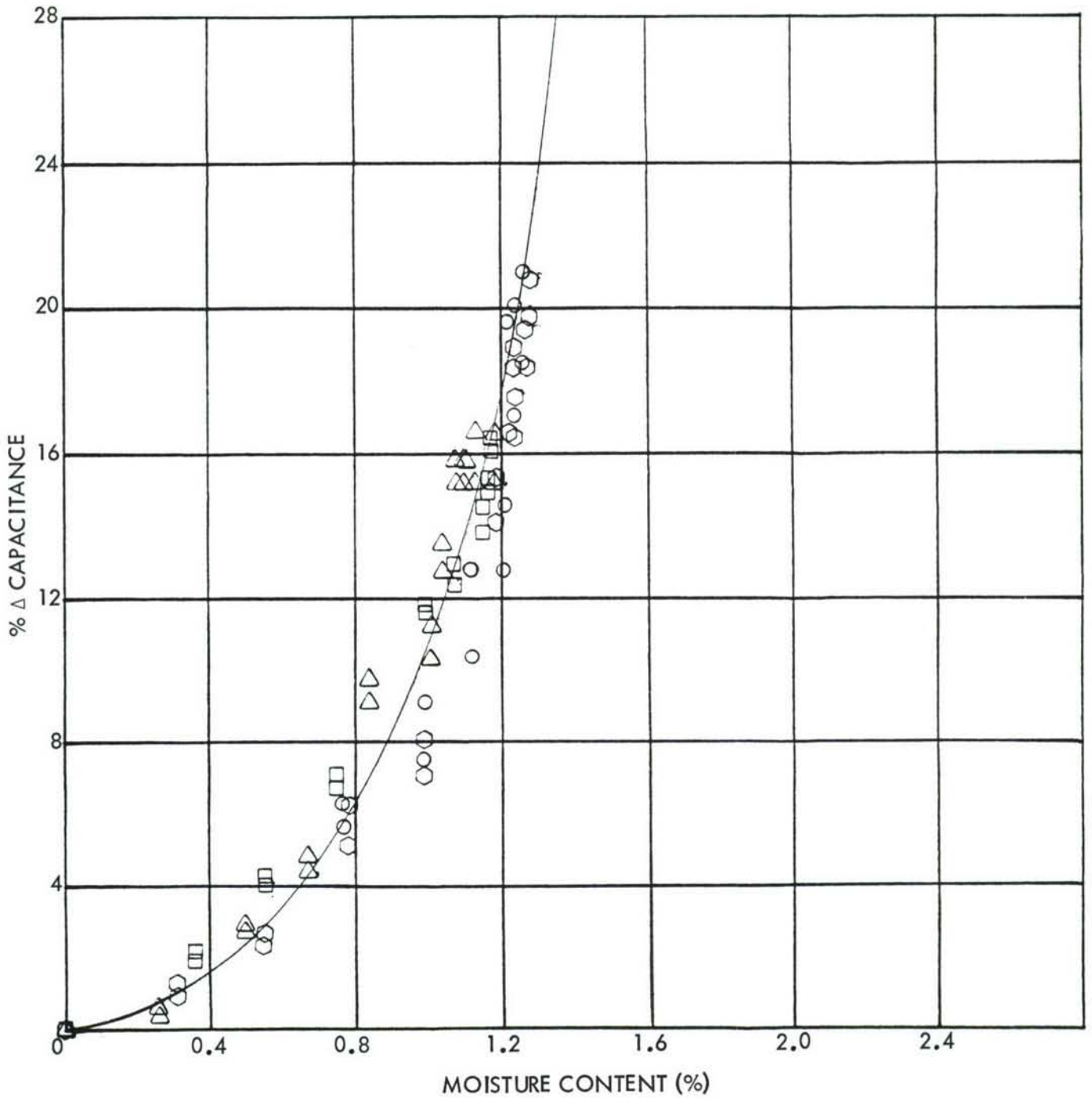

Figure 46. Moisture Content/Capacitance Correlation for Specimen BFD

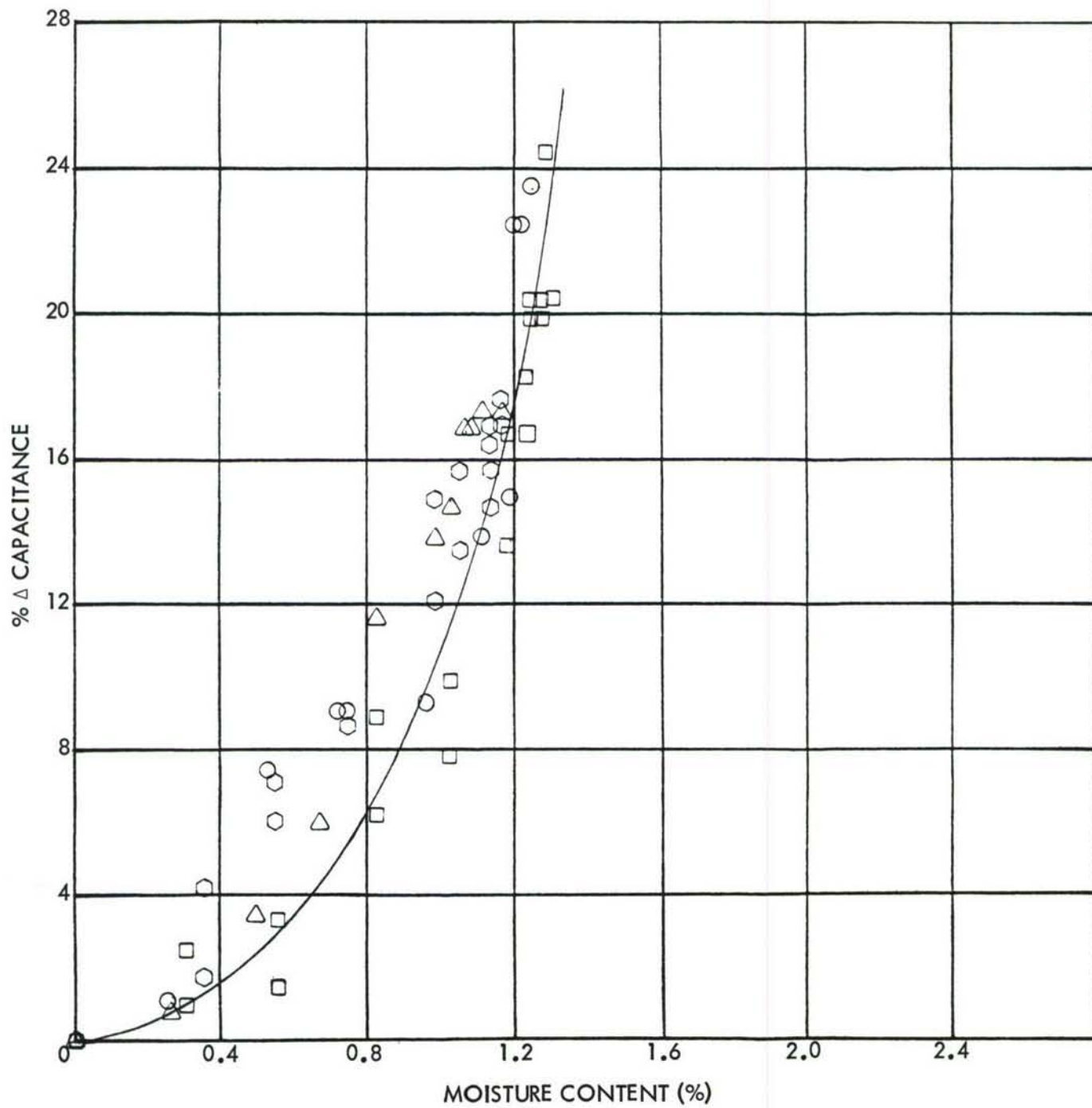

Figure 47. Moisture Content/Capacitance Correlation for Specimen CFD

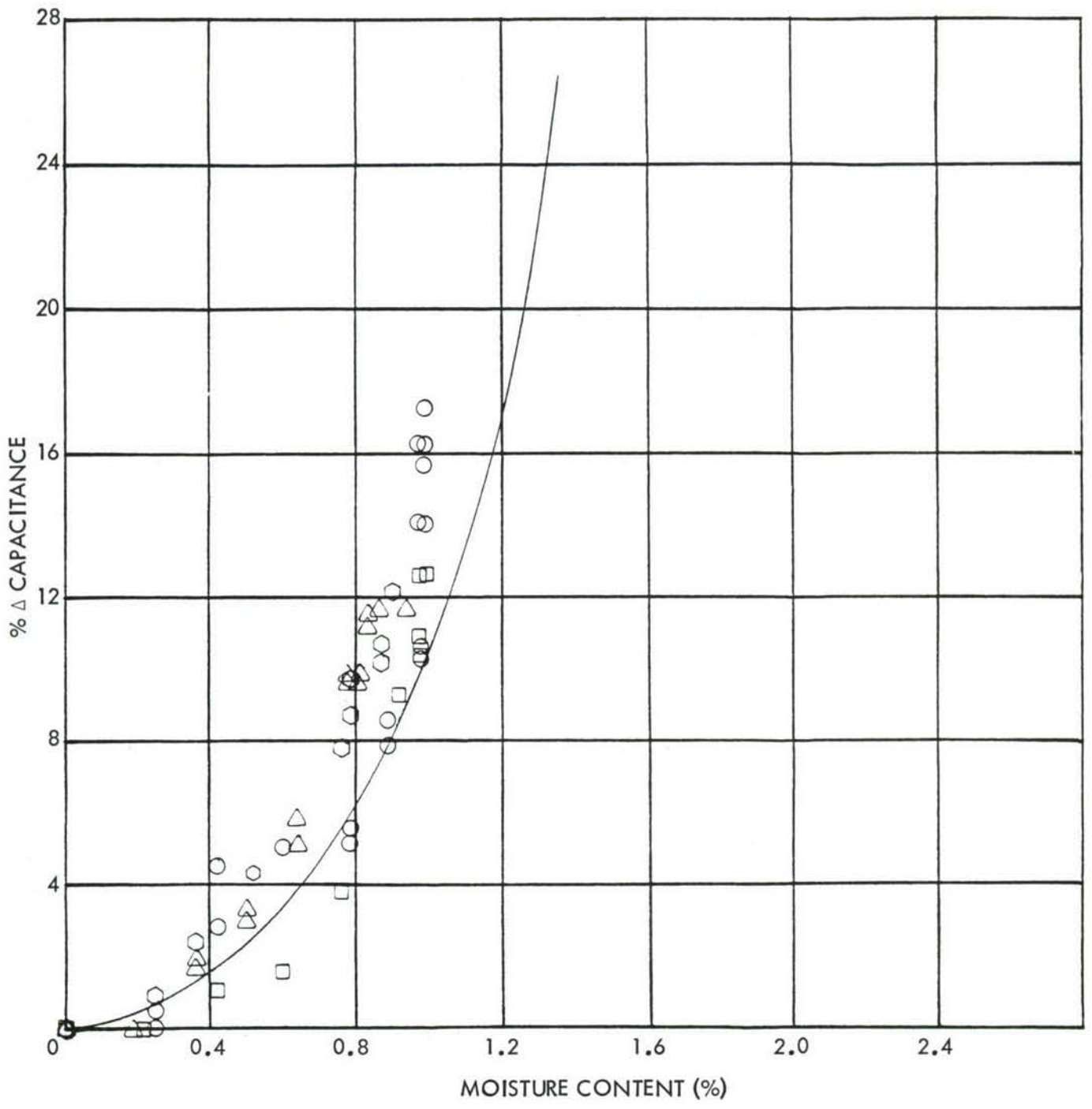
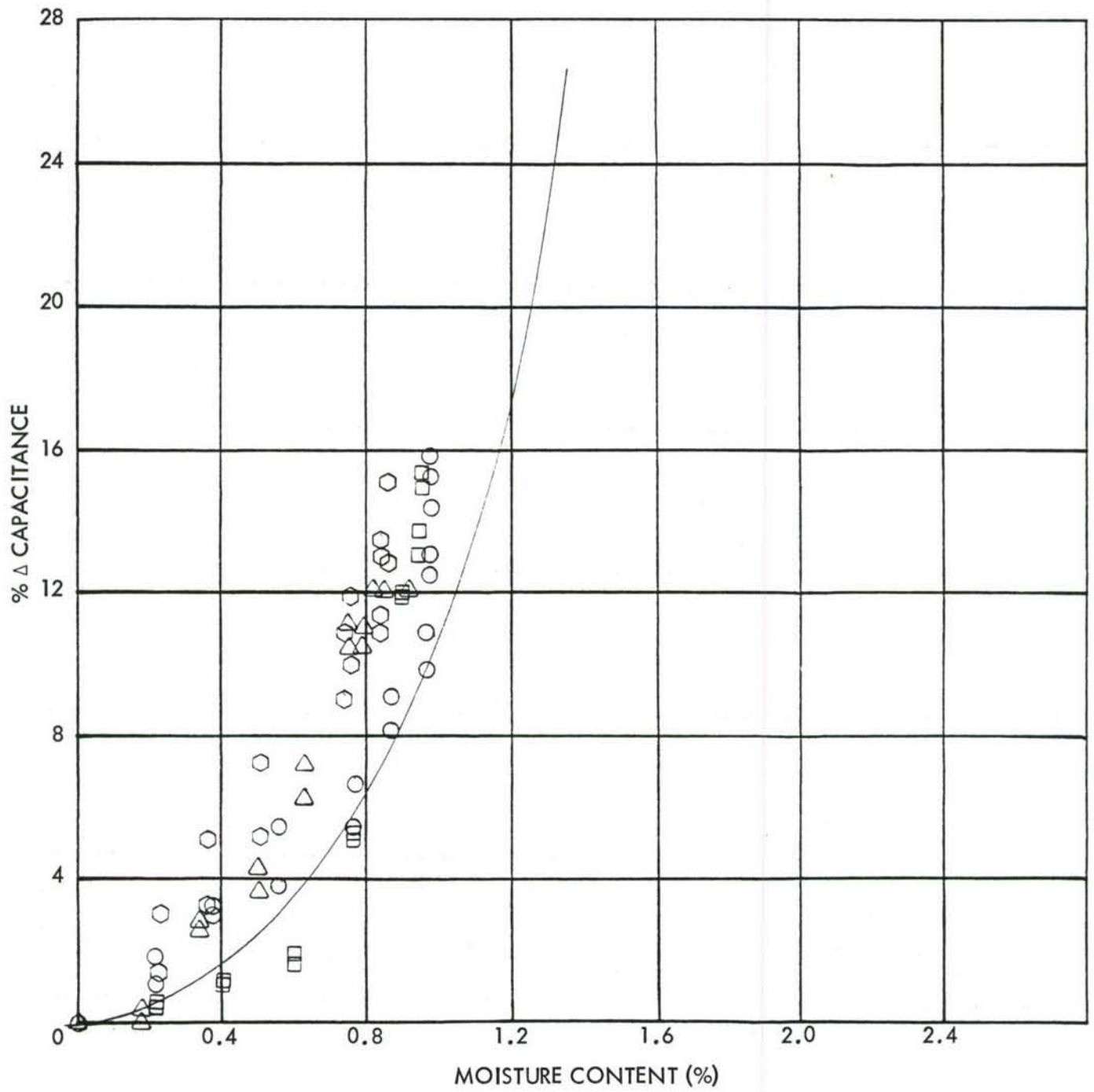

Figure 48. Moisture Content/Capacitance Correlation for Specimen DFD



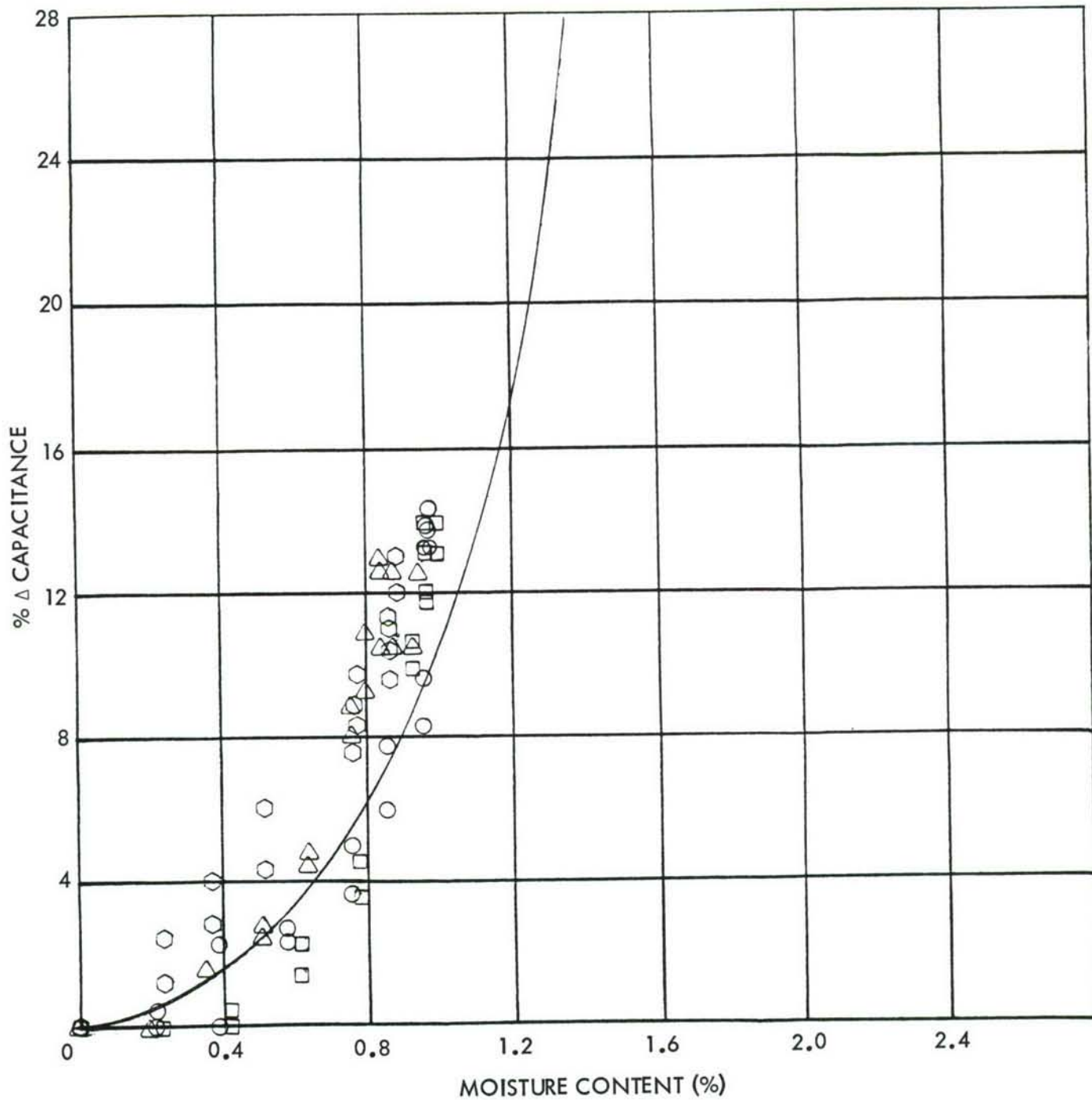

Figure 50. Moisture Content/Capacitance Correlation for Specimen FFD

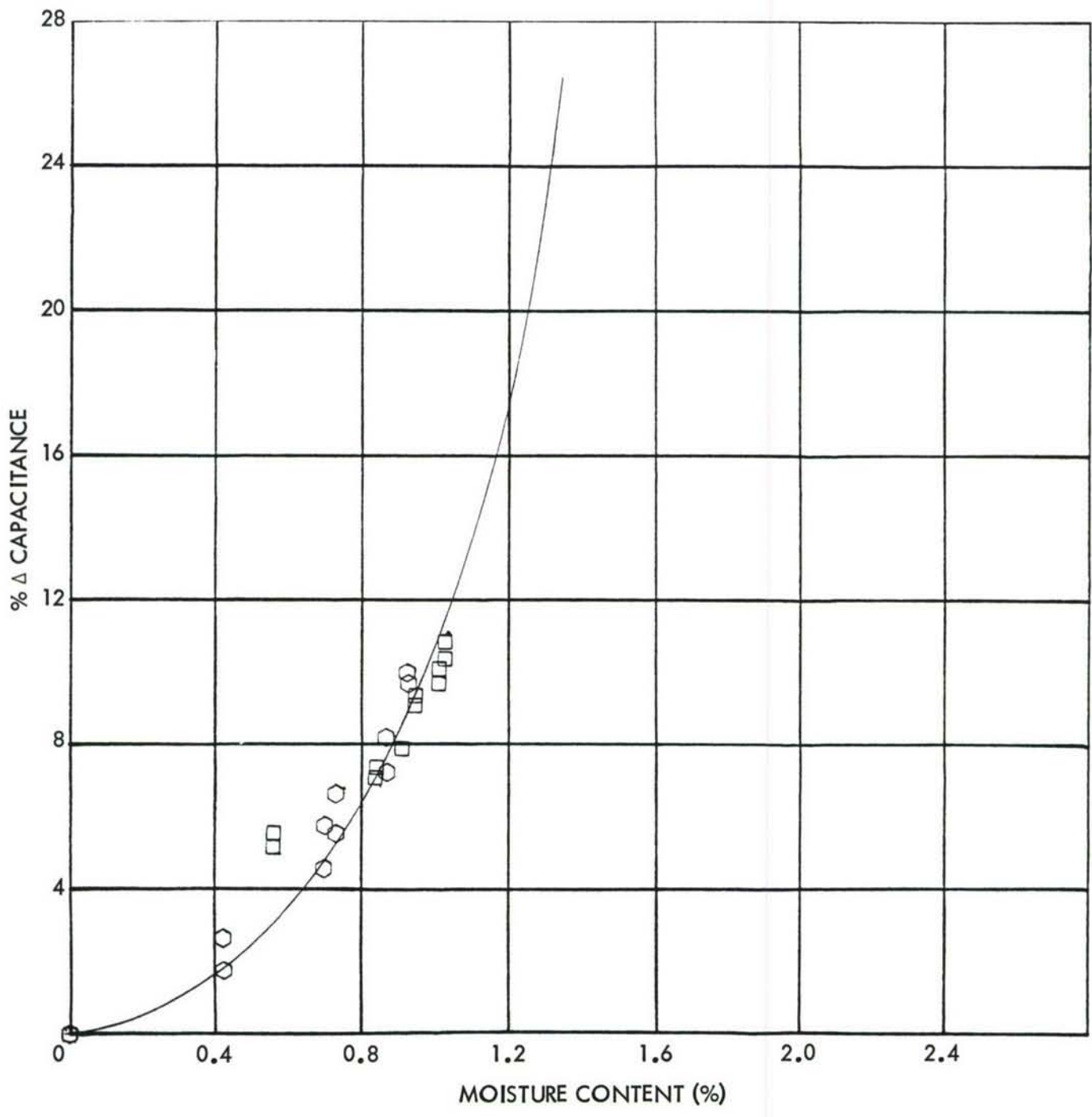

Figure 51. Moisture Content/Capacitance Correlation for Specimen GFD

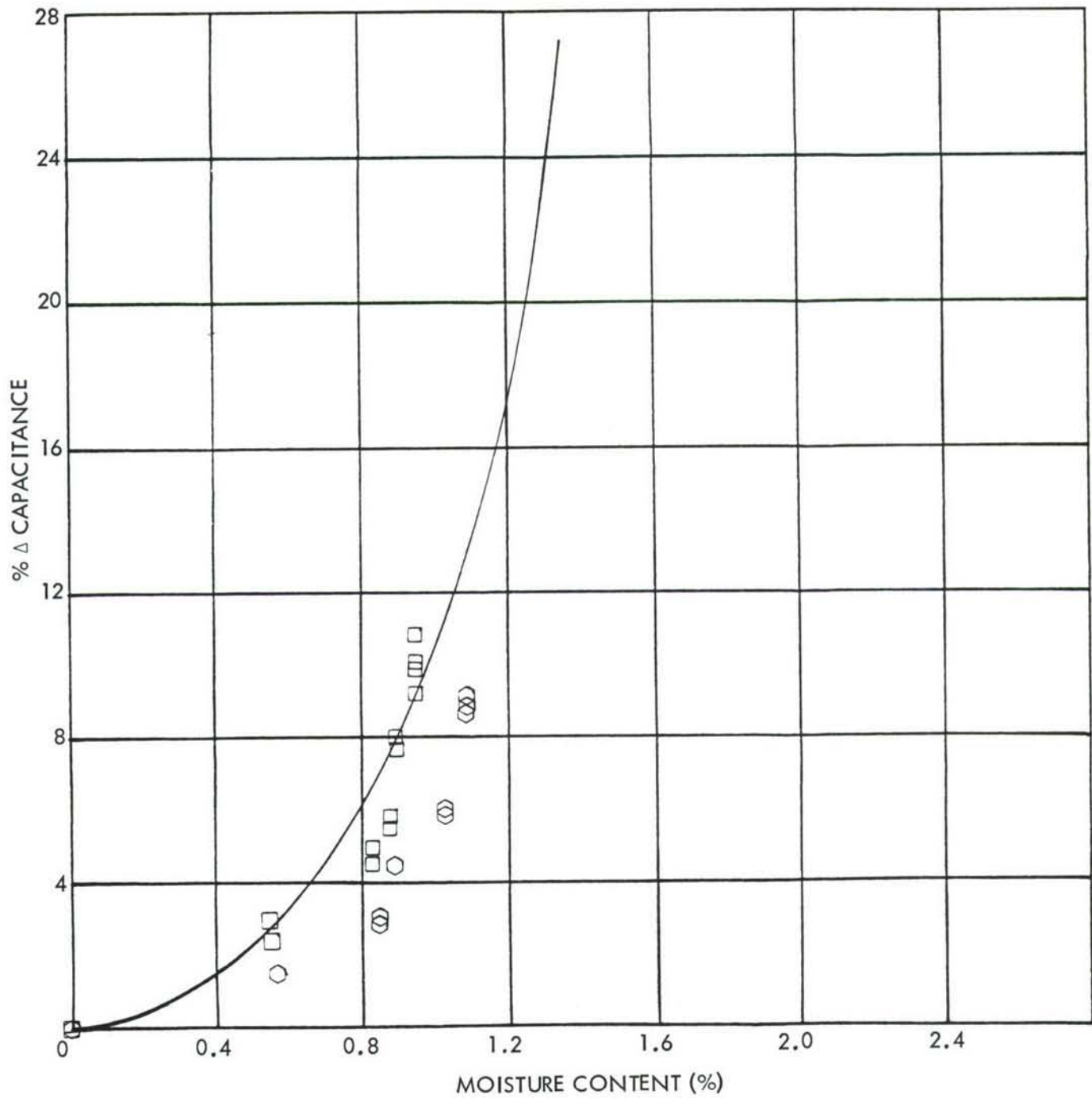

Figure 52. Moisture Content/Capacitance Correlation for Specimen HFD

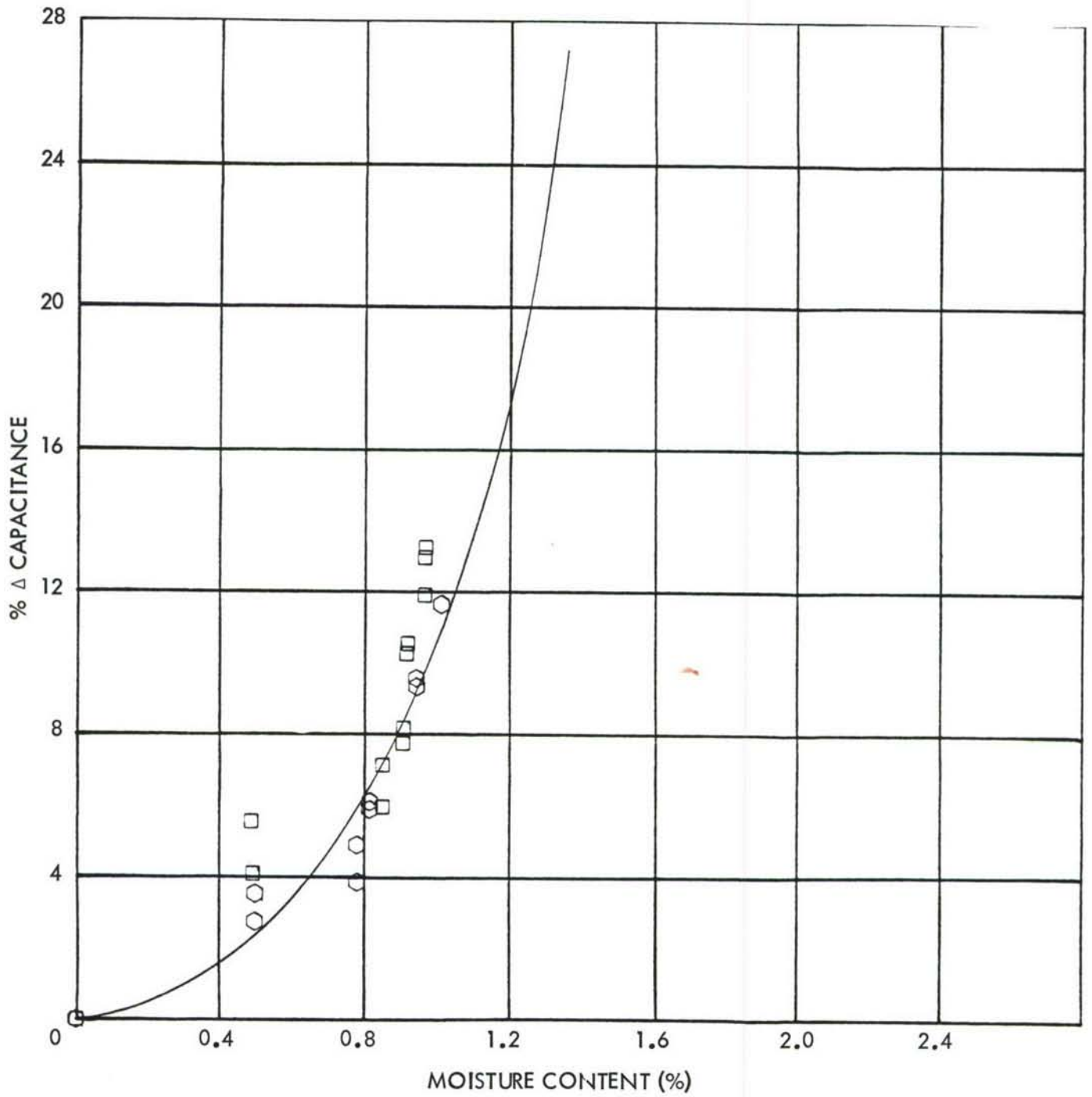

Figure 53. Moisture Content/Capacitance Correlation for Specimen IFD

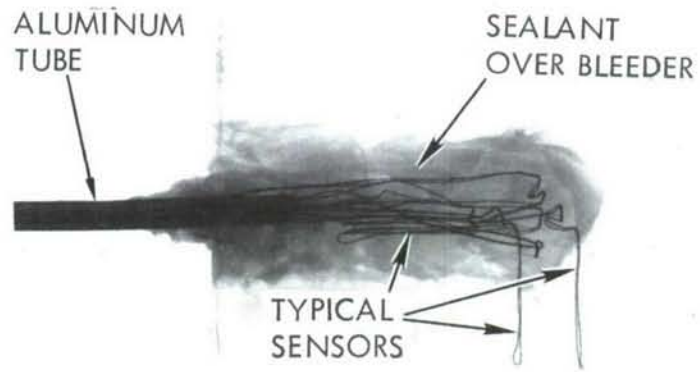

Figure 54. X-Ray Photograph Showing Sensor Installation for Specimens A and B

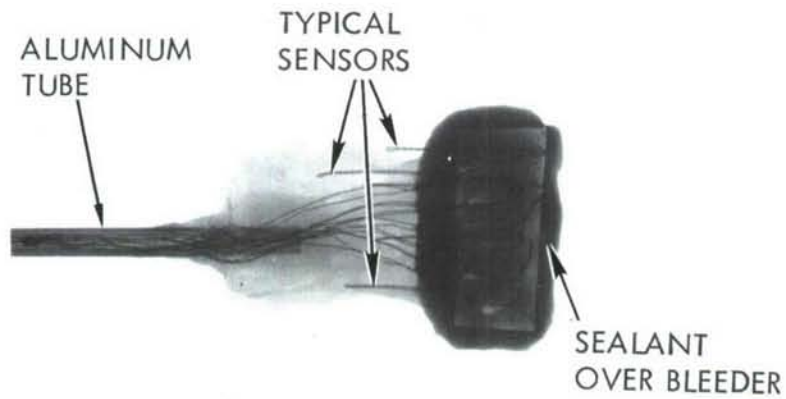

Figure 55. X-Ray Photograph Showing Sensor Installation for Specimens C and D

bleeder where the sensors emerge from the specimen, and installation of the aluminum tube on the specimens. It may be noted that the sealant area is much darker in Figure 55 than in Figure 54 indicating a greater thickness of sealant on Specimens C and D than for Specimens A and B. These four specimens were exposed to one cycle of the environmental conditions of 160°F/98% RH Absorb and 160°F/0% RH Desorb in the environmental test equipment described in paragraph 2.1.1.3.

As discussed in paragraph 2.2.1.10 above, the absorption environment inside the environmental test equipment was changed to an environment below the room temperature dew point during the weight and capacitance measurement time periods. However, the environmental fan was left turned on during data taking.

The weight, capacitance, and time data, including the capacitance for each of the six sensors of each of the four specimens exposed to one cycle of the environmental condition of 160°F/98% RH absorb and 160°F/0% RH desorb, are tabulated in Tables A-54 through A-57. In general, an examination of the tables shows more consistent data for Specimens A and B than for C and D. This may be accounted for by the X-rays as described above. Figures 56 through 59 show the moisture content versus the capacitance change in pico-farads. Figures 56 and 57 show the expected behavior even though the moisture content is high at saturation. By taking into account the known weight of sealant around the sensor emerging area and the potting of the aluminum tube, this 2.1 to 2.3 percent moisture content at saturation reduces to approximately 1.4 which is the expected amount. Specimens C and D are more erratic although the desorb cycles seem to fall back in line. This behavior is again explained by the larger amount of sealant at the sensor exit points.

The local moisture content versus percent capacitance change for the five different thickness locations for Specimens A and B is shown in Figures 60 through 64. The local moisture content versus percent capacitance change for the three different thicknesses for Specimens C and D is shown in Figures 65, 66, and 67. The local moisture is based on distance from the center; therefore, the sensor locations are as follow:

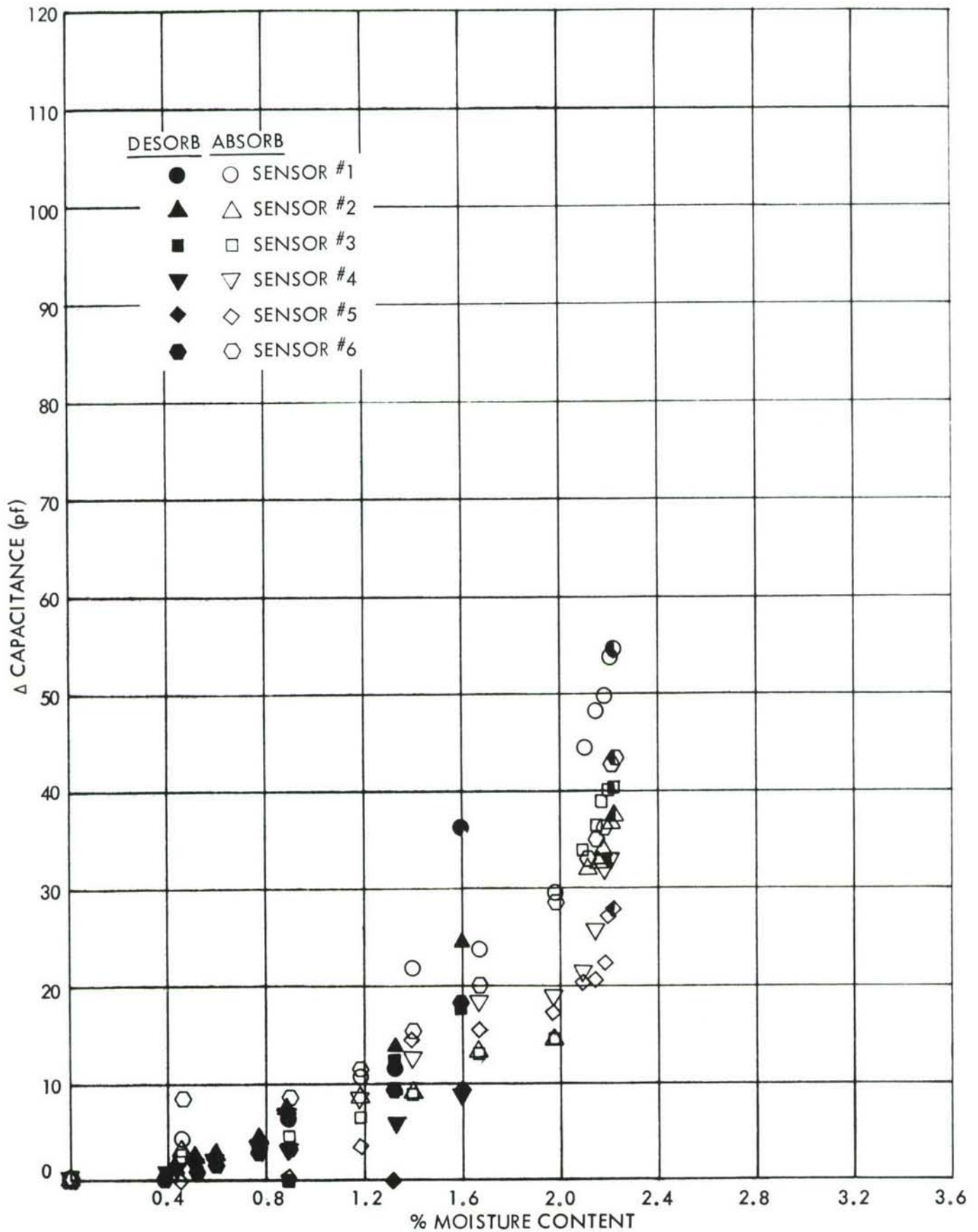

Figure 56. Δ Capacitance Versus Moisture Content for 13-Ply Specimen A

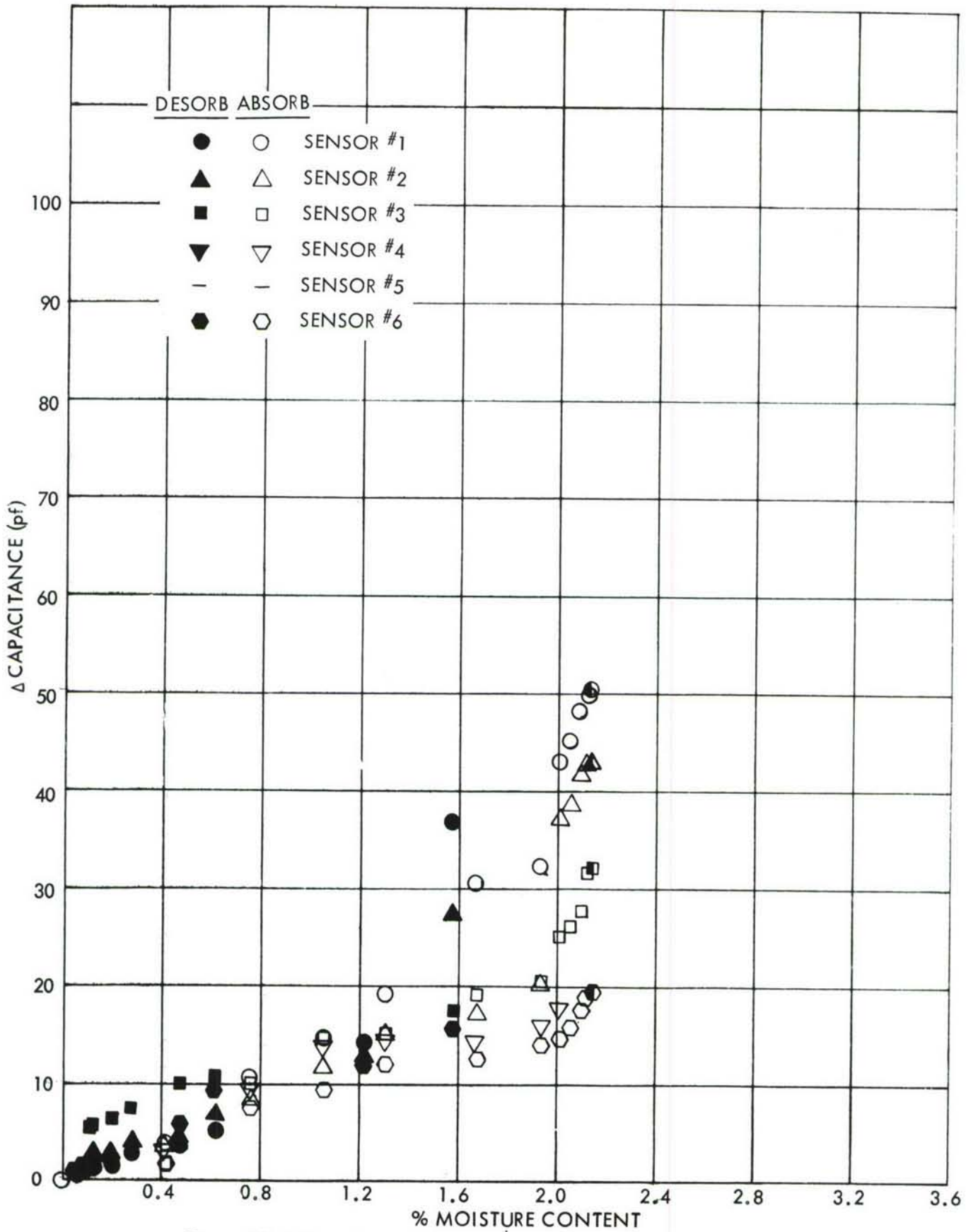

Figure 57. Δ Capacitance Versus Moisture Content for 13-Ply Specimen B

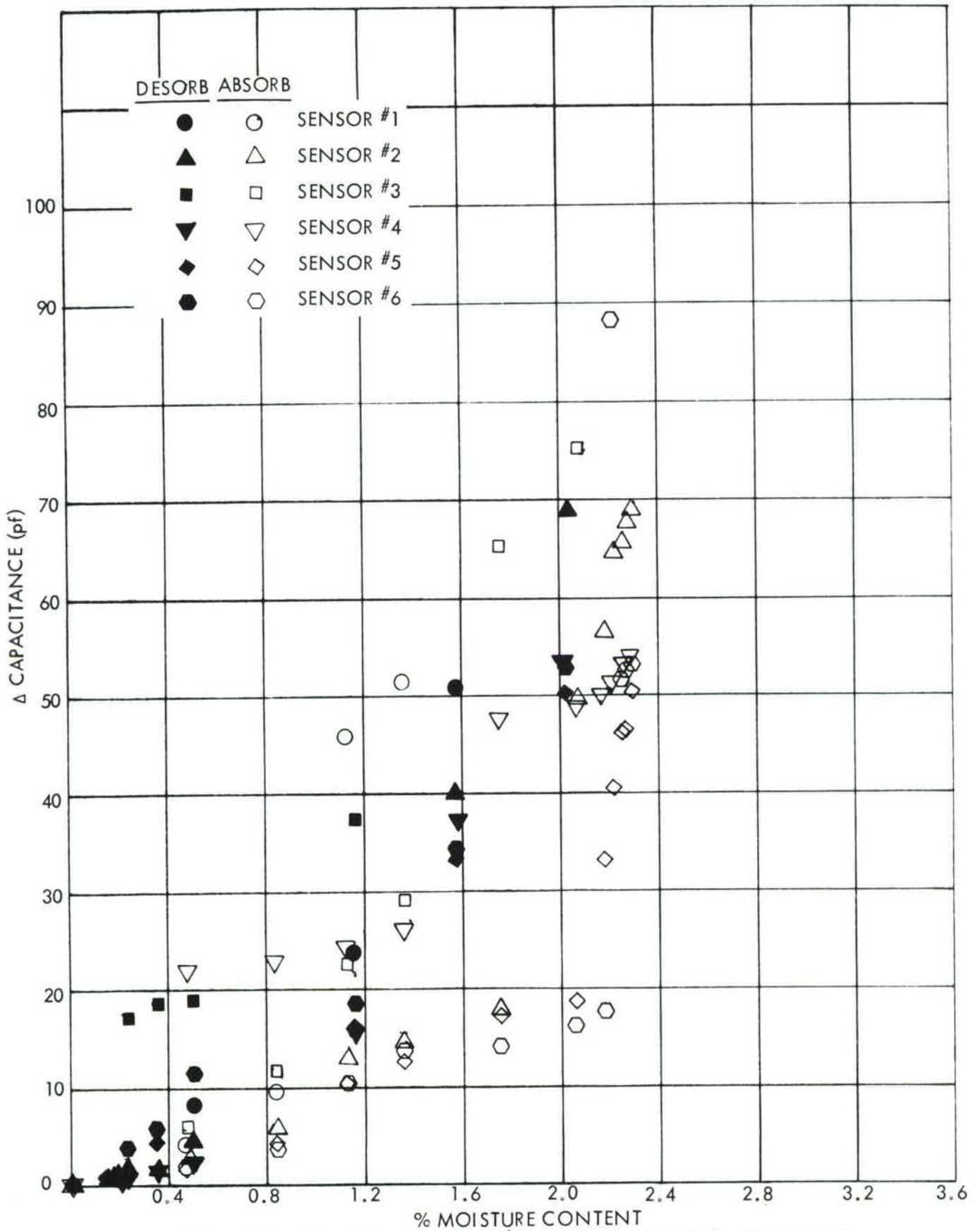

Figure 58. Δ Capacitance Versus Moisture Content for 13-Ply Specimen C

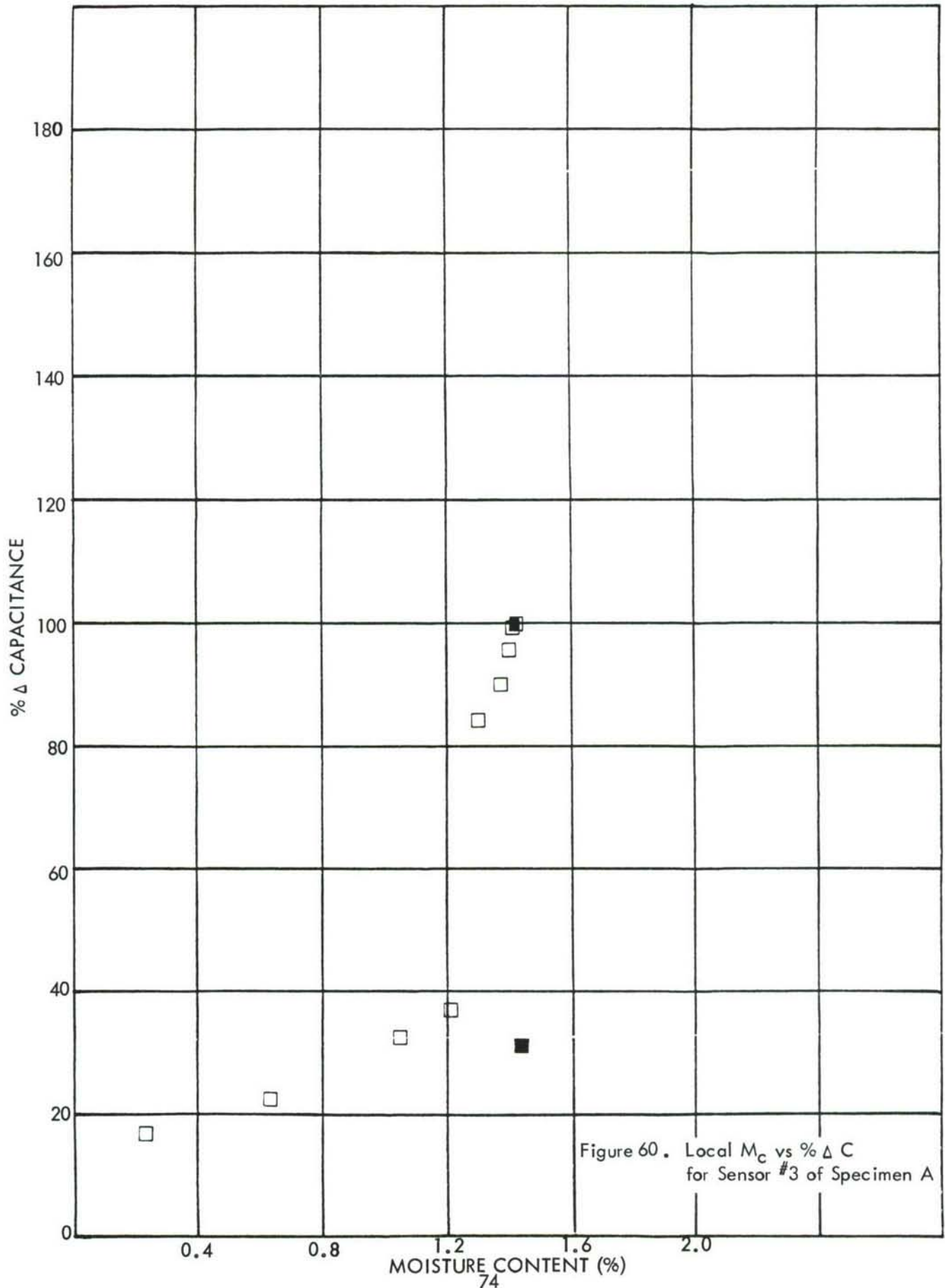

Figure 60. Local M_c vs % ΔC
for Sensor #3 of Specimen A

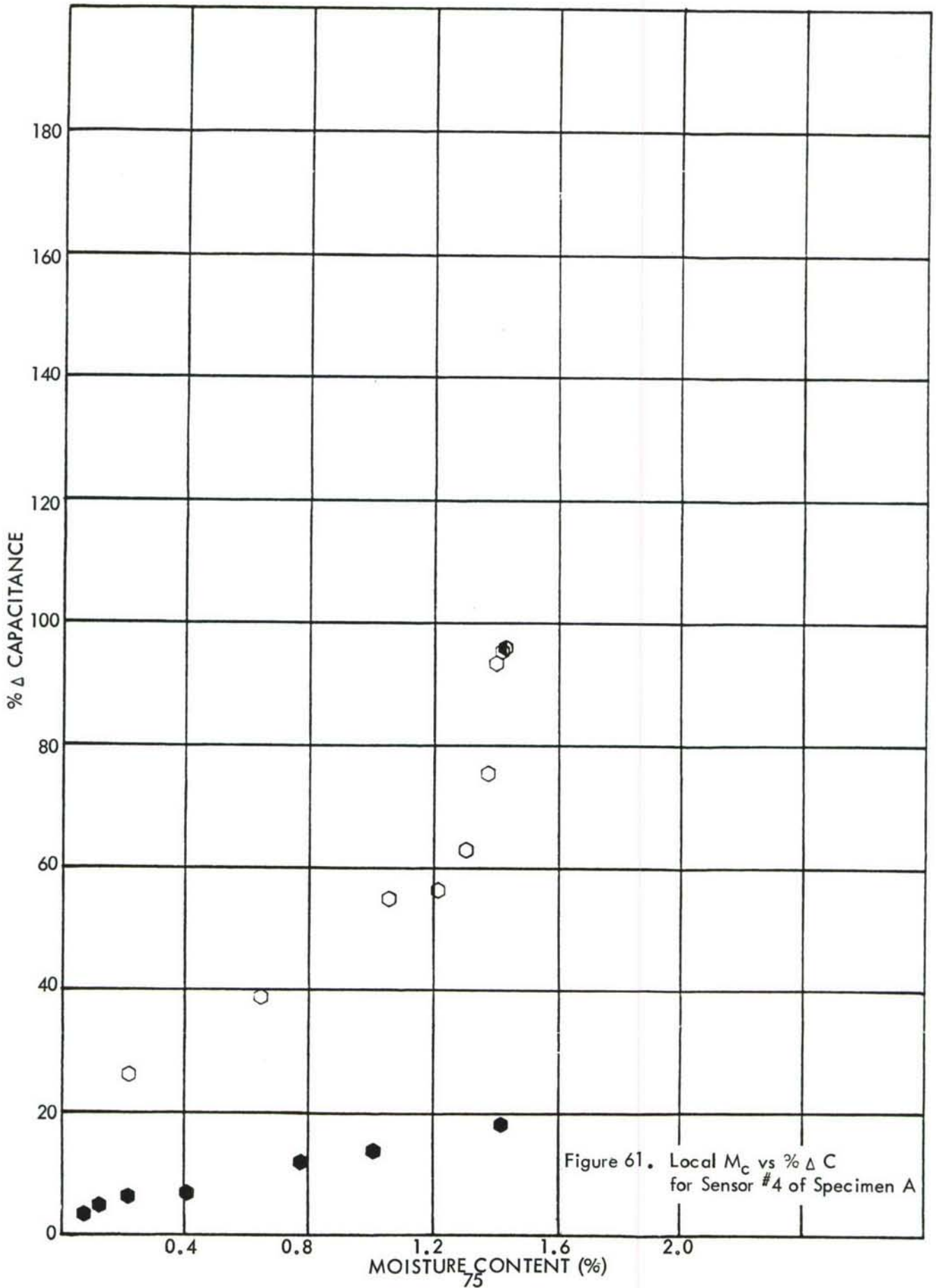
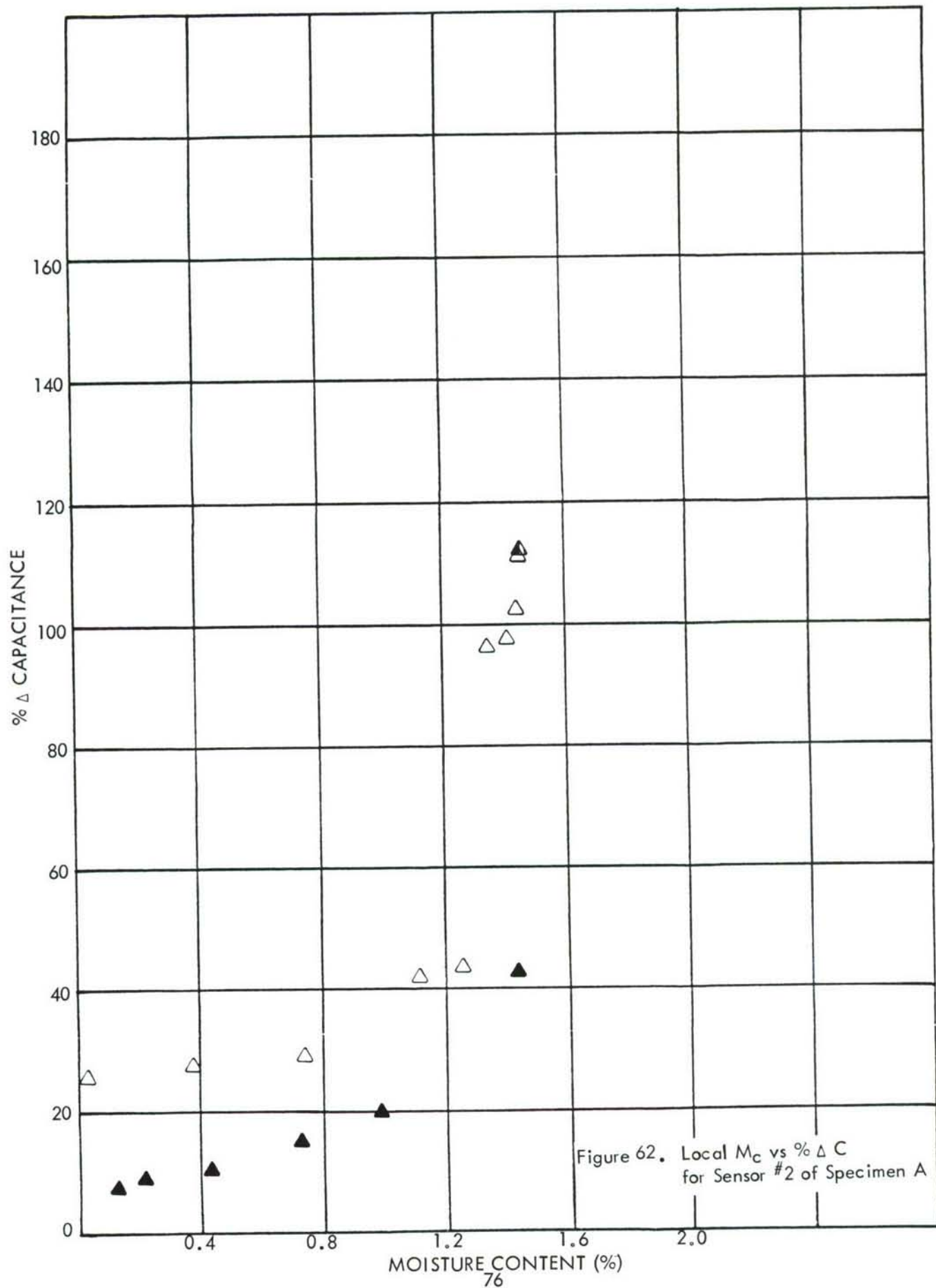
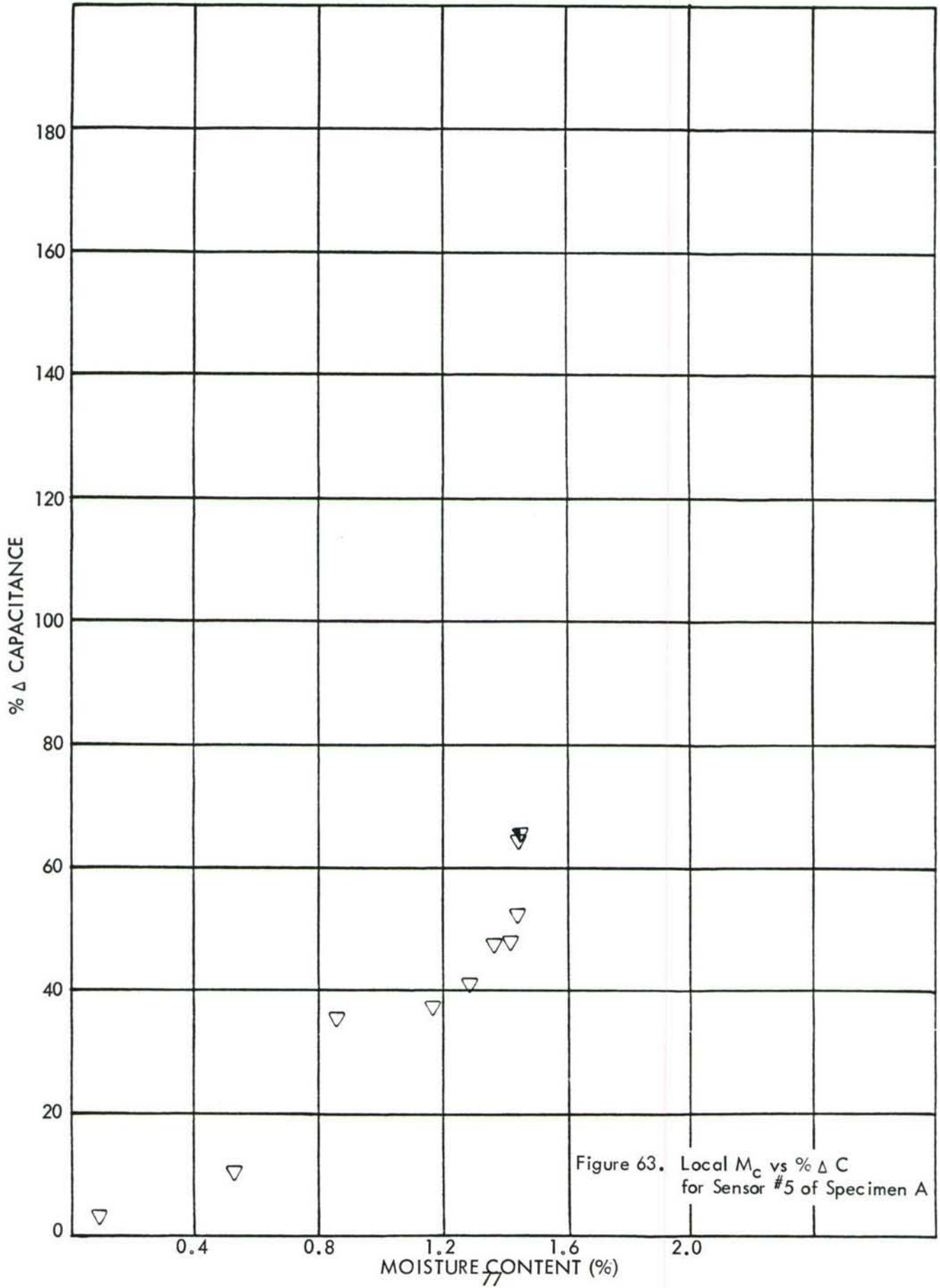

Figure 61. Local M_c vs % ΔC for Sensor #4 of Specimen A





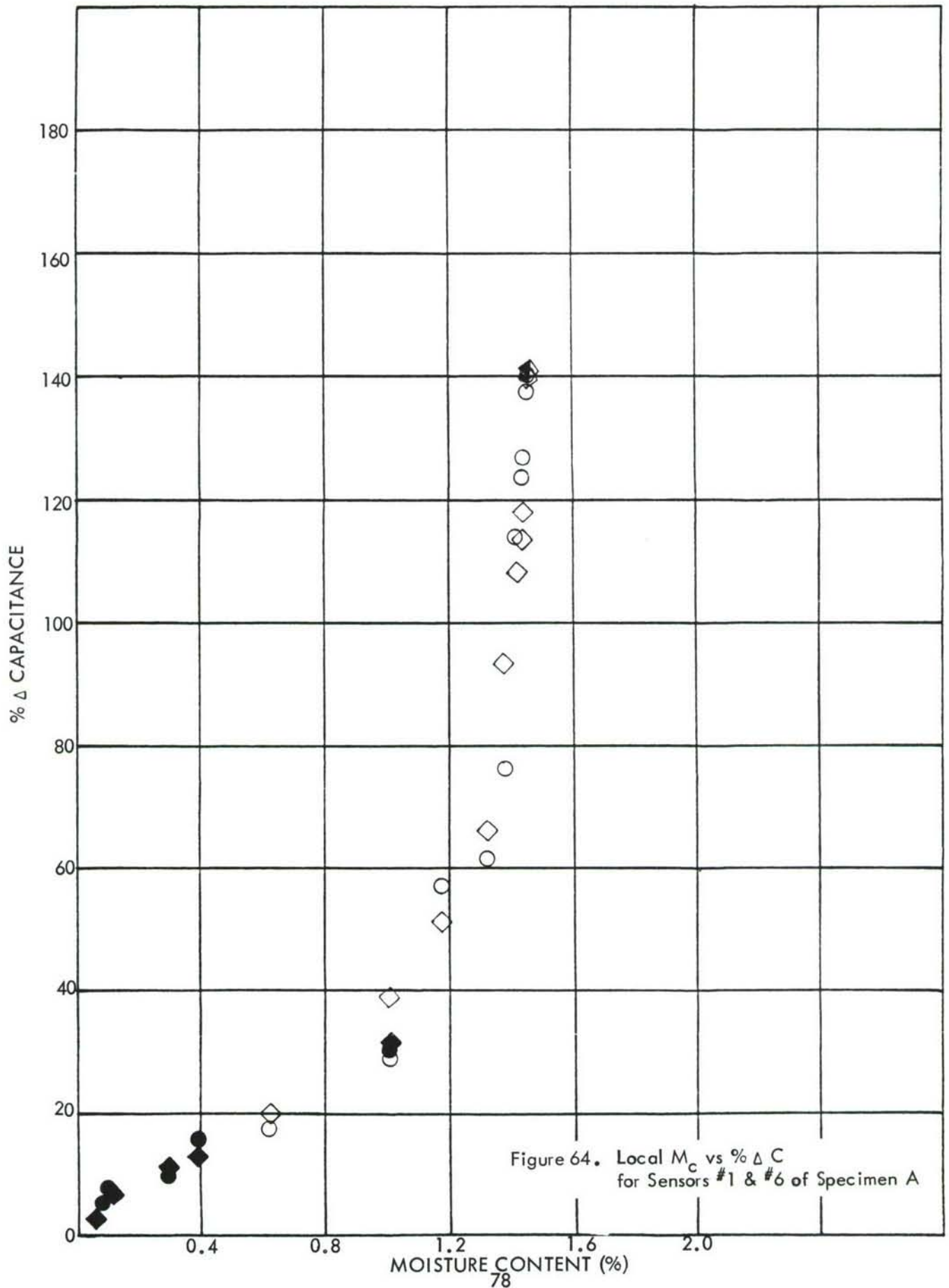
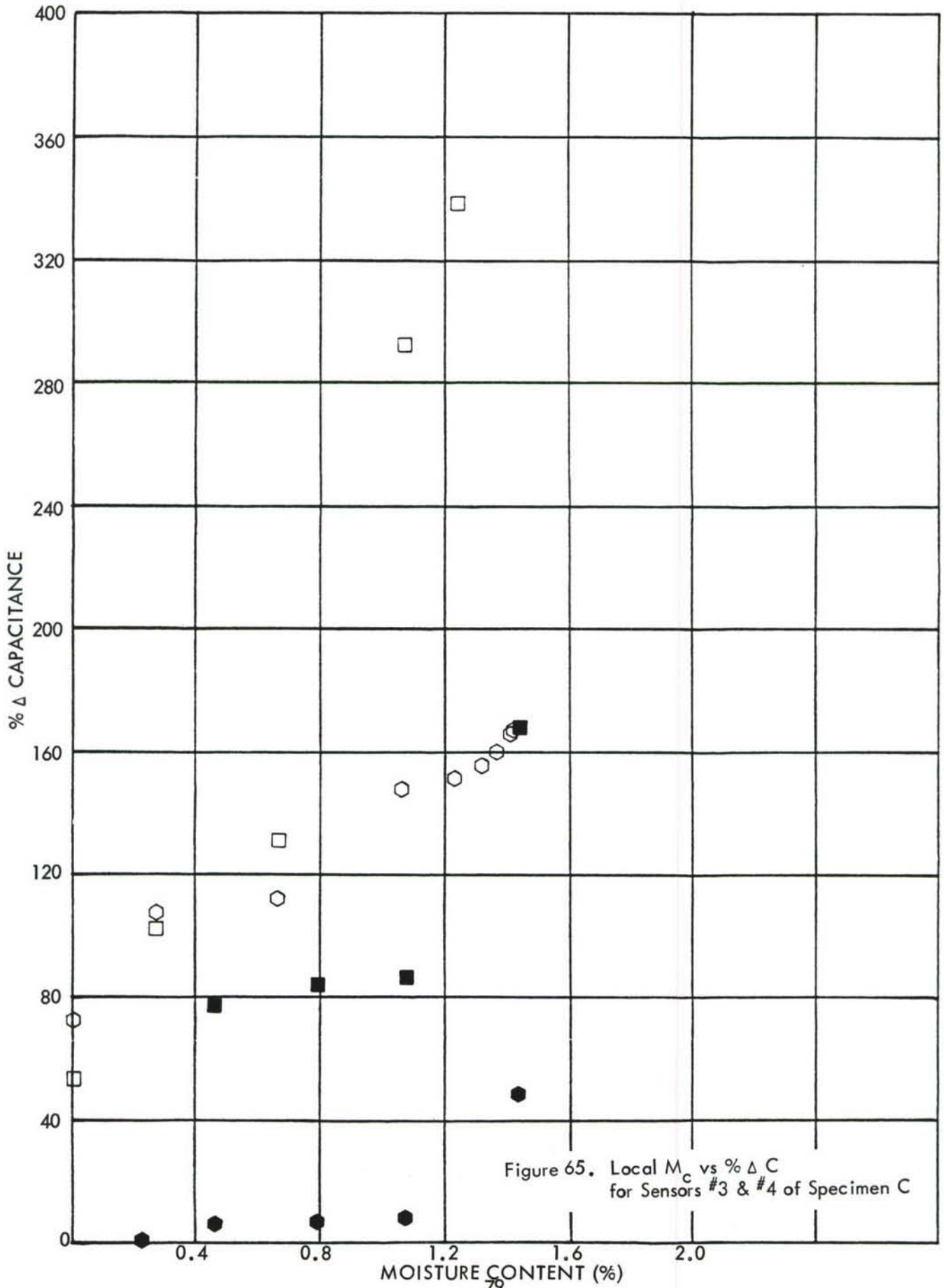
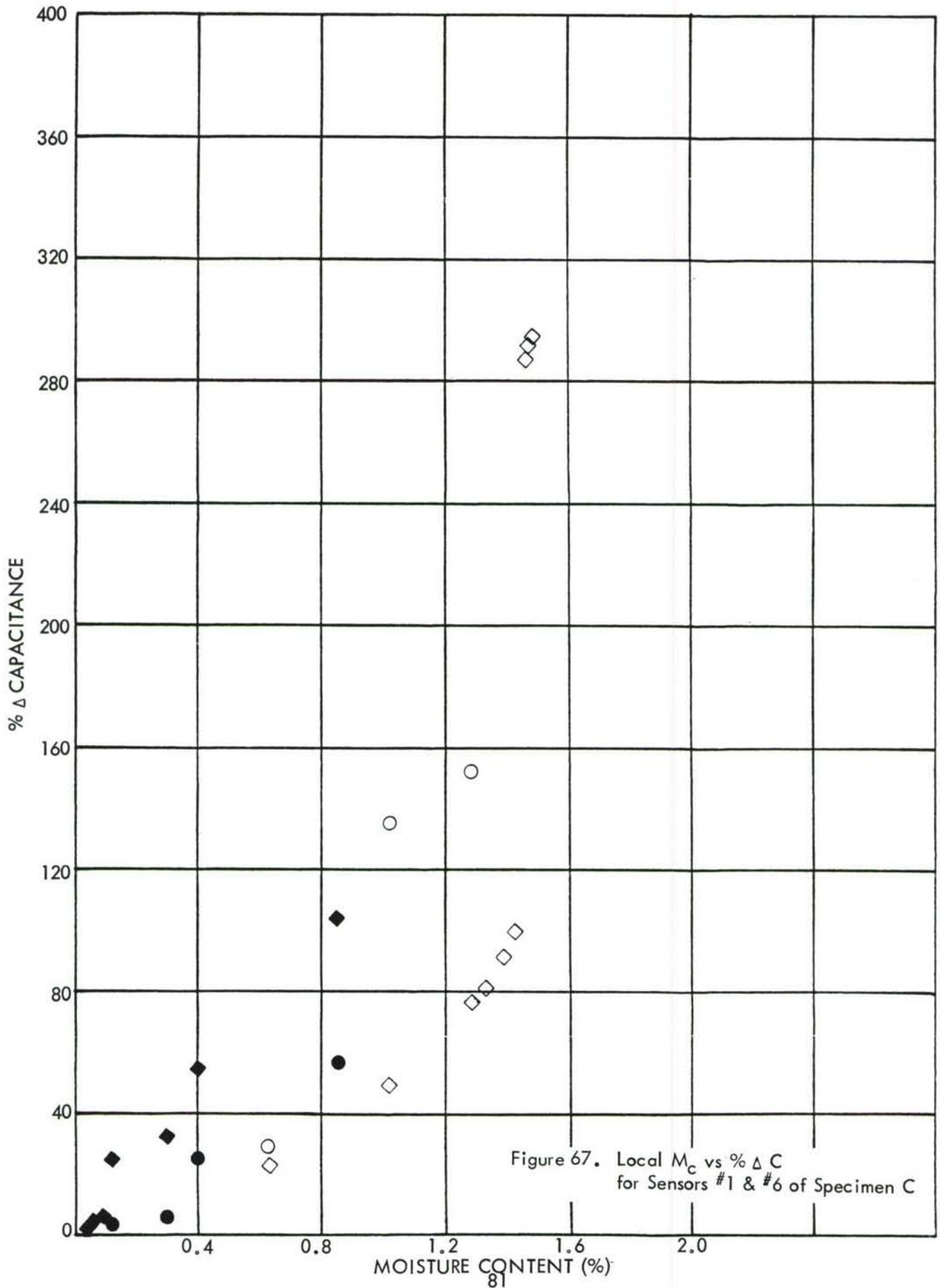

Figure 64. Local M_c vs $\% \Delta C$ for Sensors #1 & #6 of Specimen A





<u>Distance From Center (Inch)</u>	<u>Specimen Nos.</u>	<u>Sensor Nos.</u>
0.0000	A & B	3
0.0055	A & B	4
0.0110	A & B	2
0.0165	A & B	5
0.0275	A & B	1 & 6
0.0055	C & D	3 & 4
0.0165	C & D	2 & 5
0.0275	C & D	1 & 6

From the local moisture content versus percent capacitance change shown in Figures 60 through 64 which are representative of Specimens A and B, it is concluded that the shape of each of the curves is alike and that a good correlation is indicated except for Sensors #1 and #6 which are located the closest to the surface. The general shape of this curve is the same as the others, and the percent capacitance is high only at the extreme steep portion of the curve as shown in Figure 64.

From the local moisture content versus percent capacitance change shown in Figures 65, 66, and 67 which are representative of Specimens C and D, it is concluded that the data is erratic and that the capacitance is too high. This condition indicates that free moisture may be getting into the sensors or the sealant used for these specimens is allowing extra moisture to enter the specimen.

2.3 CONCLUSIONS AND RECOMMENDATIONS

2.3.1 Conclusions

It has been demonstrated during this program that parallel wire sensors acting as capacitors may be placed at various positions through the thickness of graphite/epoxy composites and measure the capacitance at the plane of that sensor. It was shown that this capacitance changes as the moisture content in the composite changes and that, for at least three of the ten environmental conditions tested, a good correlation was demonstrated between the composite's moisture content at the sensor location and the percent capacitance change during two absorb and two desorb cycles at each of the three conditions. These three environmental conditions included both room temperature and 120°F and both 93% RH and 75% RH during absorption. The 75% RH was at both temperatures; and, from the 75% RH data at those two temperatures, it was concluded that the correlation of moisture content and percent capacitance change was not a function of the temperature at least for those two temperatures. The change in relative humidity does not appear to change the shape of the moisture content/capacitance correlation curve.

The good correlation discussed above was obtained with the Type IV 3-ply specimens of Task I. In addition, a good moisture content/percent capacitance change correlation was obtained for the Type III, six sensors, 13-ply Specimens A and B of Task II, as shown in the local moisture content/percent capacitance change curves. However, Sensors 1 and 6 of those specimens had higher readings at saturation than the other four sensors. This may be accounted for by those sensors being nearest the surface of the specimen and nearer complete saturation. Since the moisture content/capacitance curve is extremely steep near the saturation point, a very small moisture content change can produce a large capacitance change.

Other conclusions reached during this program include:

- o Both erratic moisture content and capacitance was experienced from condensation around the environmental chamber port area allowing moisture to condense on the specimens and the lead wires during data taking time periods.

- o Extremely high capacitance readings were experienced from the sensors detecting free moisture believed to have been caused by cracks in shrink tubing and from improperly sealed ends and connecting points of tubing.
- o Moisture content/capacitance correlation was better in all conditions tested, where erratic readings were apparent, for the desorb part of the cycle than for the absorb part.
- o In situ weight and capacitance readings in the environmental chamber were more consistent with the environmental fan turned on during data taking until it was decided to reduce the humidity and temperature conditions inside the environmental chamber below the room temperature dew point during the data taking time period. With that dry condition inside the environmental chamber, the most consistent data was experienced by turning the environmental fan off.
- o Type IV specimens produced the most consistent data.
- o The structural integrity and durability of the composite containing the embedded sensors was not evaluated during this program.

2.3.2 Recommendations

Recommendations for further work to improve the moisture content/capacitance correlation in composites include:

- o Further work in sensor/specimen design and development to include improved isolation and insulation of lead wires from sensors to the tips, restricting the dielectric to the intended sensor area only.
- o Extend moisture content/capacitance correlation to the remaining environmental conditions where correlation was doubtful.
- o Extend moisture content/capacitance correlation to other graphite/resin composites, other fiber-reinforced resin composites, and to hybrid composites.

- o Conduct program to determine the structural integrity and durability of composites containing the embedded sensors.
- o Conduct flight service program to verify experimental data.

REFERENCES

1. Browning, C. E., "The Effects of Moisture on the Properties of High Performance Epoxy Resins and Composites," AFML-TR-72-94, 1972.
2. Hertz, J., "Investigation into the High-Temperature Strength Degradation of Fiber-Reinforced Resin Composites During Ambient Aging," Report No. GDCA-DGB73-005, Contract NAS 8-27435, June 1973.
3. Shirrell, C. D., Halpin, J. C., and Browning, C. E., "Moisture - An Assessment of Its Impact on the Design of Resin Based Advanced Composites," NASA TM X-3377, 1976.

APPENDIX

This appendix contains the raw data of time, capacitance, and weight of each specimen and each cycle exposed to the various environmental conditions used during this program as Tables A-1 through A-57. In addition, the analytical local moisture content versus the square root of time for each of the sensor locations used in this program are included as Figures A-1 through A-26.

The percent moisture content is computed from the readings shown in the tables as follows:

$$\% M_c = \frac{\text{Wt. at Discrete Times} - \text{Tare Wt.} - \text{Dry Wt.}}{\text{Dry Wt.}}$$

The tare includes the weight of the sensors, the sensor leads, connector pins, molded elastomer, and brass tubes filled with silicone rubber as shown in Figure 8 for the Type IV specimen.

TABLE A-1. CYCLE NO. 1 EXPOSURE TO 120°F/98% RH ABSORB AND 120°F/0% RH DESORB FOR SPECIMEN 3B

Condition: 120°F/98% RH Absorb; 120°F/0% RH Desorb

Tare 0.6777 g Dry Weight 3.5129 g Dry Capacitance 26.5 pf

Specimen No. 3B Absorb No. 1 Start Date 8/31/78

<u>Time (hours)</u>	<u>Weight (g)</u>	<u>Capacitance (pf)</u>
0.0	3.9355 \triangle	61.2
1.0	3.9665 \triangle	-
2.0	3.9735 \triangle	76.9
3.0	3.9806 \triangle	73.4
20.0	3.9732 \triangle	76.5
22.5	3.9765 \triangle	77.0
23.5	3.9788 \triangle	78.7
27.5	3.9814 \triangle	76.5

\triangle Use tare weight 0.4203 gms. Also readings were taken with environmental chamber fan off.

\triangle Use tare weight 0.4226 gms. Readings were taken with environmental chamber fan on.

Desorb No. 1 Start Date 9/6/78

<u>Time (hours)</u>	<u>Weight (g)</u>	<u>Capacitance (pf)</u>
0.0	4.2125	30.6
1.0	4.2082	30.1
2.0	4.2066	29.7
3.0	4.2039	30.1
4.0	4.2014	29.5
22.0	4.1965	30.3
23.0	4.1965	30.1
26.0	4.1965	29.1
28.0	4.1952	29.7
45.0	4.1911	29.8

TABLE A-2. CYCLE NO. 2 EXPOSURE TO 120°F/98% RH ABSORB AND 120°F/0% RH DESORB FOR SPECIMEN 3B

Condition: 120°F/98% RH Absorb; 120°F/0% RH Desorb
 Tare 0.6777 g Dry Weight 3.5129 g Dry Capacitance 26.5 pf
 Specimen No. 3B Absorb No. 2 Start Date 9/8/78

<u>Time (hours)</u>	<u>Weight (g)</u>	<u>Capacitance (pf)</u>
0.0	4.2042	58.3
1.0	4.2314	82.3
2.0	4.2413	85.6
3.0	4.2439	72.0
69.0	4.2477	75.4
93.0	4.2371	79.0

Desorb No. 2 Start Date 9/12/78

<u>Time (hours)</u>	<u>Weight (g)</u>	<u>Capacitance (pf)</u>
0.0	4.2146	30.8
1.0	4.2119	29.5
2.0	4.2099	28.7
3.0	4.2081	28.4
21.0	4.1954	27.7
22.0	4.1954	28.1
25.0	4.1933	27.2
27.5	4.1933	26.6
44.5	4.1918	26.8
49.5	4.1918	26.6
52.5	4.1918	26.3
68.5	4.1909	26.5

TABLE A-3. CYCLE NO. 1 EXPOSURE TO 120°F/98% RH ABSORB AND 120°F/0% RH DESORB FOR SPECIMEN 6B

Condition: 120°F/98% RH Absorb; 120°F/0% RH Desorb

Tare 0.5814 g Dry Weight 3.5499 g Dry Capacitance 36.7 pf

Specimen No. 6B Absorb No. 1 Start Date 8/31/78

<u>Time (hours)</u>	<u>Weight (g)</u>	<u>Capacitance (pf)</u>
0.0	3.8734 \triangle	65.7
1.0	3.8860 \triangle	-
2.0	3.9325 \triangle	73.2
3.0	3.9115 \triangle ₂	76.0
20.0	3.9128 \triangle ₂	86.3
22.0	3.9128 \triangle ₂	91.2
23.0	3.9156 \triangle ₂	91.9
26.0	3.9200 \triangle ₂	97.1

\triangle Tare 0.3235 gms. Fan off.

\triangle ₂ Tare 0.3235 gms. Fan on.

Desorb No. 1

Start Date 9/6/78

<u>Time (hours)</u>	<u>Weight (g)</u>	<u>Capacitance (pf)</u>
0.0	4.1488	44.6
1.167	4.1474	42.2
2.167	4.1452	44.0
3.167	4.1441	43.1
4.167	4.1433	40.7
22.167	4.1362	41.7
23.0	4.1362	41.6
26.0	4.1362	41.7
28.0	4.1346	40.4
45.0	4.1315	38.9

TABLE A-4. CYCLE NO. 2 EXPOSURE TO 120°F/98% RH ABSORB
AND 120°F/0% RH DESORB FOR SPECIMEN 6B

Condition: <u>120°F/98% RH</u> Absorb; <u>120°F/0% RH</u> Desorb		
Tare <u>0.5814</u> g	Dry Weight <u>3.5499</u> g	Dry Capacitance <u>36.7</u> pf
Specimen No. <u>6B</u>	Absorb No. <u>2</u>	Start Date <u>9/8/78</u>
<u>Time (hours)</u>	<u>Weight (g)</u>	<u>Capacitance (pf)</u>
0.0	4.1476	48.3
1.0	4.1666	62.3
2.0	4.1690	83.3
3.0	4.1708	91.2
69.0	4.2040	82.3
93.0	4.1908	88.5

Desorb No. <u>2</u>		Start Date <u>9/12/78</u>
<u>Time (hours)</u>	<u>Weight (g)</u>	<u>Capacitance (pf)</u>
0.0	4.1537	41.9
1.0	4.1511	40.1
2.0	4.1486	39.6
3.0	4.1477	39.1
21.5	4.1345	39.6
22.5	4.1345	39.5
25.5	4.1334	38.4
27.5	4.1334	39.4
44.5	4.1315	38.9
49.5	4.1315	38.8
52.0	4.1315	38.3
68.0	4.1315	36.7

TABLE A-5. CYCLE NO. 1 EXPOSURE TO 120°F/98% RH ABSORB
AND 120°F/0% RH DESORB FOR SPECIMEN 1B

Condition: 120°F/98% RH Absorb; 120°F/0% RH Desorb

Tare 0.7485 g Dry Weight 3.4482 g Dry Capacitance 37.6 pf

Specimen No. 1B Absorb No. 1 Start Date 10/11/78

<u>Time (hours)</u>	<u>Weight (g)</u>	<u>Capacitance (pf)</u>
0.00	4.1967	37.6
0.25	4.2133	47.4
1.00	4.2213	51.9
2.25	4.2243	57.4
4.00	4.2251	59.1
6.25	4.2272	62.7
22.25	4.2307	75.9
25.00	4.2334	78.7
27.60	4.2353	79.9
30.25	4.2374	83.1
40.25	4.2442	Shorted
50.25	4.2427	-
54.25	4.2446	-
119.25	4.2692	-

Desorb No. 1 Start Date 10/16/78

<u>Time (hours)</u>	<u>Weight (g)</u>	<u>Capacitance (pf)</u>
0.00	4.2692	-
0.25	4.2265	-
1.00	4.2238	-
2.25	4.2227	-
4.00	4.2216	-
6.25	4.2142	-
23.25	4.2034	-
25.00	4.2027	-
27.60	4.2023	-
30.25	4.2016	-
47.25	4.2006	-
52.25	4.2000	-
71.25	4.1973	-

TABLE A-6. CYCLE NO. 2 EXPOSURE TO 120°F/98% RH ABSORB
AND 120°F/0% RH DESORB FOR SPECIMEN 1B

Condition:	<u>120°F/98% RH</u>	Absorb;	<u>120°F/0% RH</u>	Desorb
Tare	<u>0.7485 g</u>	Dry Weight	<u>3.4482 g</u>	Dry Capacitance <u>37.6 pf</u>
Specimen No.	<u>1B</u>	Absorb No.	<u>2</u>	Start Date <u>10/19/78</u>
<u>Time (hours)</u>		<u>Weight (g)</u>		<u>Capacitance (pf)</u>
0.00		4.1973		45.8
0.25		4.2212		46.4
1.00		4.2240		55.5
2.25		4.2257		56.3
4.00		4.2294		58.9
6.25		4.2336		60.2
25.00		4.2403		68.5
27.60		4.2484		69.6
30.25		4.2526		70.5
95.25		4.2991		76.4

Desorb No.	<u>2</u>	Start Date	<u>10/23/78</u>
<u>Time (hours)</u>		<u>Weight (g)</u>	<u>Capacitance (pf)</u>
0.00		4.2991	76.4
0.25		4.2376	72.3
1.00		4.2238	53.8
2.25		4.2221	50.1
4.00		4.2193	48.4
6.25		4.2185	47.9
47.25		4.2078	34.0
71.25		4.2029	34.0
76.25		4.2028	32.1
96.25		4.2023	30.4
168.25		4.2008	24.3

TABLE A-7. CYCLE NO. 1 EXPOSURE TO 120°F/98% RH ABSORB
AND 120°F/0% RH DESORB FOR SPECIMEN 2A

Condition: 120°F/98% RH Absorb; 120°F/0% RH Desorb

Tare 0.9545 g Dry Weight 3.3980 g Dry Capacitance 32.5 pf

Specimen No. 2A Absorb No. 1 Start Date 10/11/78

<u>Time (hours)</u>	<u>Weight (g)</u>	<u>Capacitance (pf)</u>
0.00	4.3586	32.5
0.25	4.3657	35.6
1.00	4.3691	36.3
2.25	4.3722	38.0
4.00	4.3734	39.4
6.00	4.3864	41.5
22.00	4.3919	148.2
25.00	4.3968	156.1
27.60	4.3972	160.2
30.00	4.4010	178.2
46.00	4.4033	185.8
50.00	4.4119	208.0
54.00	4.4129	219.0
119.00	4.4150	222.0

Desorb No. 1 Start Date 10/16/78

<u>Time (hours)</u>	<u>Weight (g)</u>	<u>Capacitance (pf)</u>
0.00	4.4150	222.0
0.25	4.3951	183.1
1.00	4.3933	180.2
2.25	4.3874	175.0
4.00	4.3839	174.7
6.25	4.3769	165.0
23.25	4.3631	65.1
25.00	4.3629	58.3
27.60	4.3625	41.7
30.25	4.3610	40.7
47.25	4.3591	37.8
52.25	4.3588	37.5
71.25	4.3571	37.1

TABLE A-8. CYCLE NO. 2 EXPOSURE TO 120°F/98% RH ABSORB
AND 120°F/0% RH DESORB FOR SPECIMEN 2A

Condition:	<u>120°F/98% RH</u>	Absorb;	<u>120°F/0% RH</u>	Desorb
Tare	<u>0.9545 g</u>	Dry Weight	<u>3.3980 g</u>	Dry Capacitance <u>32.5</u> pf
Specimen No.	<u>2A</u>	Absorb No.	<u>2</u>	Start Date <u>10/19/78</u>
<u>Time (hours)</u>		<u>Weight (g)</u>		<u>Capacitance (pf)</u>
0.00		4.3571		37.1
0.25		4.3756		50.6
1.00		4.3898		101.2
2.25		4.3902		118.3
4.00		4.3986		203.2
6.25		4.3992		217.0
23.25		4.4085		224.0
25.00		4.4144		245.0
27.60		4.4151		254.0
30.25		4.4198		265.0
97.25		4.4233		266.0

Desorb No.	<u>2</u>	Start Date	<u>10/23/78</u>
<u>Time (hours)</u>		<u>Weight (g)</u>	<u>Capacitance (pf)</u>
0.00		4.4233	266.0
0.25		4.4035	Shorted
1.00		4.3936	-
2.25		4.3889	-
4.00		4.3883	-
6.25		4.3862	-
47.25		4.3585	-
71.25		4.3556	-
76.25		4.3556	-
96.25		4.3533	-
168.25		4.3525	-

TABLE A-9. CYCLE NO. 1 EXPOSURE TO 120°F/98% RH ABSORB
AND 120°F/0% RH DESORB FOR SPECIMEN 14A

Condition: <u>120°F/98% RH</u>		Absorb; <u>120°F/0% RH</u>		Desorb
Tare	<u>0.9484 g</u>	Dry Weight	<u>3.5631 g</u>	Dry Capacitance <u>21.9 pf</u>
Specimen No.	<u>14A</u>	Absorb No.	<u>1</u>	Start Date <u>10/11/78</u>
<u>Time (hours)</u>	<u>Weight (g)</u>	<u>Capacitance (pf)</u>		
0.00	4.5126	33.1		
0.25	4.5245	34.0		
1.00	4.5263	34.5		
2.25	4.5338	35.4		
4.00	4.5371	37.6		
20.00	4.5393	118.3		
25.00	4.5492	134.1		
27.60	4.5514	134.6		
43.60	4.5551	149.9		
47.60	4.5568	151.8		
51.60	4.5571	151.9		
116.60	4.5591	157.3		
Desorb No.	<u>1</u>	Start Date <u>10/16/78</u>		
<u>Time (hours)</u>	<u>Weight (g)</u>	<u>Capacitance (pf)</u>		
0.00	4.5591	157.3		
0.25	4.5363	153.9		
1.00	4.5359	153.5		
2.25	4.5356	152.6		
4.00	4.5325	151.1		
6.25	4.5294	148.8		
23.25	4.5179	76.2		
25.00	4.5173	65.5		
27.60	4.5168	52.2		
30.25	4.5151	49.0		
47.25	4.5139	37.0		
52.25	4.5133	36.8		
71.25	4.5116	36.7		

TABLE A-10. CYCLE NO. 2 EXPOSURE TO 120°F/98% RH ABSORB
AND 120°F/0% RH DESORB FOR SPECIMEN 14A

Condition: 120°F/98% RH Absorb; 120°F/0% RH Desorb

Tare 0.9484 g Dry Weight 3.5631 g Dry Capacitance 21.9 pf

Specimen No. 14A Absorb No. 2 Start Date 10/19/78

<u>Time (hours)</u>	<u>Weight (g)</u>	<u>Capacitance (pf)</u>
0.00	4.5116	34.7
0.25	4.5393	41.9
1.00	4.5408	42.5
2.25	4.5421	58.8
4.00	4.5457	66.3
6.25	4.5489	77.1
23.25	4.5608	145.9
25.00	4.5615	146.8
27.60	4.5649	149.6
30.25	4.5678	150.0
95.25	4.5923	156.2

Desorb No. 2 Start Date 10/23/78

<u>Time (hours)</u>	<u>Weight (g)</u>	<u>Capacitance (pf)</u>
0.00	4.5923	156.2
0.25	4.5462	148.1
1.00	4.5408	145.5
2.25	4.5394	144.6
4.00	4.5350	143.2
6.25	4.5338	141.9
47.25	4.5292	39.4
71.25	4.5227	31.3
76.25	4.5224	31.1
96.25	4.5138	28.2
168.25	4.5115	21.9

TABLE A-11. INITIAL ABSORB CYCLE FOR SPECIMEN 3A EXPOSED TO 120°F/50% RH ABSORB AND 120°F/0% RH DESORB

Condition: <u>120°F/50% RH</u>		Absorb; <u>120°F/0% RH</u>		Desorb
Tare	<u>0.4419</u> g	Dry Weight	<u>3.4028</u> g	Dry Capacitance <u>40.5</u> pf
Specimen No.	<u>3A</u>	Absorb No.	<u>Initial</u>	Start Date <u>9/20/78</u>
<u>Time (hours)</u>		<u>Weight (g)</u>		<u>Capacitance (pf)</u>
0.0	△	3.8668		41.1
1.0	△	3.8691		45.1
2.0	△	3.8702		48.3
20.0	△	3.8709		48.7
21.0	△	3.8709		47.9
22.5		3.8677		46.5
25.5		3.8671		47.4
44.0		3.8685		47.2
51.5		3.8688		47.8
116.5		3.8690		47.9
122.5		3.8690		48.2
140.5		3.8692		48.2
164.5		3.8697		48.3
170.5		3.8697		48.3
191.0		3.8702		48.5

△ Environmental Fan turned off during readings.

TABLE A-12. CYCLE NO. 1 EXPOSURE TO 120°F/50% RH ABSORB
AND 120°F/0% RH DESORB FOR SPECIMEN 3A

Condition:	<u>120°F/50% RH</u>	Absorb;	<u>120°F/0% RH</u>	Desorb
Tare	<u>0.4419 g</u>	Dry Weight	<u>3.4028 g</u>	Dry Capacitance <u>40.5 pf</u>
Specimen No.	<u>3A</u>	Absorb No.	<u>1</u>	Start Date <u>10/2/78</u>
<u>Time (hours)</u>		<u>Weight (g)</u>		<u>Capacitance (pf)</u>
0.00		3.8447		40.5
0.25		3.8530		42.8
1.00		3.8541		44.2
2.25		3.8555		44.7
4.00		3.8560		45.1
6.25		3.8574		45.2

Condenser fan broke. Specimens placed in desorb and used as Absorb Cycle #2 when fixed.

Desorb No.	<u>1</u>	Start Date	<u>9/28/78</u>
<u>Time (hours)</u>		<u>Weight (g)</u>	<u>Capacitance (pf)</u>
0.00		3.8702	48.5
1.00		3.8661	48.0
2.00		3.8628	47.2
3.00		3.8621	46.8
4.50		3.8609	46.4
21.50		3.8506	44.4
26.50		3.8506	43.5
28.50		3.8504	42.2
93.50		3.8447	40.5

TABLE A-13. CYCLE NO. 2 EXPOSURE TO 120°F/50% RH ABSORB
AND 120°F/0% RH DESORB FOR SPECIMEN 3A

Condition:	<u>120°F/50% RH</u>	Absorb;	<u>120°F/0% RH</u>	Desorb
Tare	<u>0.4419</u> g	Dry Weight	<u>3.4028</u> g	Dry Capacitance <u>40.5</u> pf
Specimen No.	<u>3A</u>	Absorb No.	<u>2</u>	Start Date <u>10/5/78</u>
<u>Time (hours)</u>		<u>Weight (g)</u>		<u>Capacitance (pf)</u>
0.00		3.8472		41.3
0.25		3.8558		42.0
1.00		3.8564		44.1
2.25		3.8573		44.9
23.00		3.8618		45.9
25.00		3.8618		45.9
27.60		3.8632		46.2
30.25		3.8632		46.2
95.25		3.8691		47.3
98.25		3.8691		47.3

Desorb No.	<u>2</u>	Start Date	<u>10/9/78</u>
<u>Time (hours)</u>		<u>Weight (g)</u>	<u>Capacitance (pf)</u>
0.00		3.8691	47.3
0.25		3.8619	45.7
1.00		3.8609	45.1
2.25		3.8591	43.9

Capacitance lead wire broke.

TABLE A-14. INITIAL ABSORB CYCLE FOR SPECIMEN 8B EXPOSED TO 120°F/50% RH ABSORB AND 120°F/0% RH DESORB

Condition: <u>120°F/50% RH</u>		Absorb;	<u>120°F/0% RH</u>	Desorb	
Tare	<u>0.4617</u> g	Dry Weight	<u>3.5300</u> g	Dry Capacitance	<u>38.6</u> pf
Specimen No.	<u>8B</u>	Absorb No.	<u>Initial</u>	Start Date	<u>9/20/78</u>
<u>Time (hours)</u>	<u>Weight (g)</u>	<u>Capacitance (pf)</u>			
0.0 Δ	4.0001	40.6			
1.0 Δ	4.0041	41.7			
2.0 Δ	4.0052	42.7			
20.0 Δ	4.0087	41.9			
21.0 Δ	4.0087	43.3			
22.5	4.0055	43.0			
25.5	4.0071	43.4			
44.0	4.0084	44.5			
51.5	4.0091	45.3			
116.5	4.0124	45.5			
122.5	4.0124	45.4			
140.5	4.0131	45.5			
164.5	4.0139	45.4			
170.5	4.0139	45.4			
191.0	4.0142	45.4			

Δ Environmental Fan turned off during readings.

TABLE A-15, CYCLE NO. 1 EXPOSURE TO 120°F/50% RH ABSORB
AND 120°F/0% RH DESORB FOR SPECIMEN 8B

Condition: 120°F/50% RH Absorb; 120°F/0% RH Desorb
Tare 0.4617 g Dry Weight 3.5300 g Dry Capacitance 38.6 pf
Specimen No. 8B Absorb No. 1 Start Date 10/2/78

<u>Time (hours)</u>	<u>Weight (g)</u>	<u>Capacitance (pf)</u>
0.00	3.9917	38.6
0.25	3.9966	39.2
2.25	4.0027	41.6
4.00	4.0031	41.9
6.00	4.0035	42.3

Condenser fan broke. Specimen placed in desorb and used as Absorb Cycle #2 when fixed.

Desorb No. 1 Start Date 9/28/78

<u>Time (hours)</u>	<u>Weight (g)</u>	<u>Capacitance (pf)</u>
0.0	4.0142	45.4
1.0	4.0113	44.4
2.0	4.0101	44.1
3.0	4.0092	43.7
4.5	4.0078	43.2
21.5	3.9996	41.7
26.5	3.9995	40.9
28.5	3.9995	40.8
93.5	3.9917	38.6

TABLE A-16. CYCLE NO. 2 EXPOSURE TO 120°F/50% RH ABSORB
AND 120°F/0% RH DESORB FOR SPECIMEN 8B

Condition: <u>120°F/50% RH</u>		Absorb: <u>120°F/0% RH</u>		Desorb
Tare	<u>0.4617 g</u>	Dry Weight	<u>3.5300 g</u>	Dry Capacitance <u>38.6 pf</u>
Specimen No.	<u>8B</u>	Absorb No.	<u>2</u>	Start Date <u>10/5/78</u>
<u>Time (hours)</u>	<u>Weight (g)</u>		<u>Capacitance (pf)</u>	
0.00	3.9953		38.1	
0.25	4.0007		39.5	
1.00	4.0015		40.4	
2.25	4.0031		40.8	
4.00	4.0041		41.1	
6.25	4.0048		41.2	
23.00	Capacitance lead broke; therefore, weight and capacitance were discontinued.			

TABLE A-17. INITIAL ABSORB CYCLE FOR SPECIMEN 15B EXPOSED TO 120°F/50% RH ABSORB AND 120°F/0% RH DESORB

Condition: <u>120°F/50% RH</u> Absorb;		<u>120°F/0% RH</u> Desorb	
Tare	<u>0.5402 g</u>	Dry Weight	<u>3.5179 g</u>
		Dry Capacitance	<u>38.5 pf</u>
Specimen No.	<u>15B</u>	Absorb No.	<u>Initial</u>
			Start Date <u>9/20/78</u>
<u>Time (hours)</u>	<u>Weight (g)</u>	<u>Capacitance (pf)</u>	
0.0 \triangle	4.0581	38.5	
1.0 \triangle	4.0611	40.3	
2.0 \triangle	4.0635	41.6	
20.0 \triangle	4.0676	43.1	
21.0 \triangle	4.0676	43.5	
22.5	4.0643	44.0	
25.5	4.0651	44.4	
44.0	4.0664	Leads Broke	
51.5	4.0668		
116.5	4.0703		
122.5	4.0703		
140.5	4.0705		
164.5	4.0712		
170.5	4.0712		
191.0	4.0718		

\triangle Environmental fan turned off during readings.

TABLE A-18. CYCLE NO. 1 EXPOSURE TO 120°F/50% RH ABSORB AND 120°F/0% RH DESORB FOR SPECIMEN 15B

Condition:	<u>120°F/50% RH</u>	Absorb;	<u>120°F/0% RH</u>	Desorb	
Tare	<u>0.5402</u> g	Dry Weight	<u>3.5179</u> g	Dry Capacitance	<u>38.5</u> pf
Specimen No.	<u>15B</u>	Absorb No.	<u>1</u>	Start Date	<u>10/2/78</u>
<u>Time (hours)</u>		<u>Weight (g)</u>		<u>Capacitance (pf)</u>	
0.00		4.0461		Leads Broke	
0.25		4.0533		↑	
1.00		4.0544		↑	
2.25		4.0556		↑	
4.00		4.0563		↑	
6.00		4.0574		↓	
				Leads Broke	

Condenser fan broke. Specimen was discontinued since capacitance readings could not be taken.

Desorb No.	<u>1</u>	Start Date	<u>9/28/78</u>
<u>Time (hours)</u>		<u>Weight (g)</u>	<u>Capacitance (pf)</u>
0.0		4.0718	Leads Broke
1.0		4.0681	↑
2.0		4.0636	↑
3.0		4.0630	↑
4.5		4.0614	↑
21.5		4.0530	↑
26.5		4.0530	↑
28.5		4.0529	↑
93.5		4.0461	↓
			Leads Broke

TABLE A-19. CYCLE NO. 1 EXPOSURE TO RT/50% RH ABSORB
AND RT/0% RH DESORB FOR SPECIMEN 4B

Condition: <u>RT/50% RH</u>		Absorb; <u>RT/0% RH</u>		Desorb
Tare	<u>0.9460</u> g	Dry Weight	<u>3.4179</u> g	Dry Capacitance <u>33.4</u> pf
Specimen No.	<u>4B</u>	Absorb No.	<u>1</u>	Start Date <u>10/26/78</u>
<u>Time (hours)</u>	<u>Weight (g)</u>	<u>Capacitance (pf)</u>		
0.0	4.3639	33.4		
1.0	4.3654	35.0		
4.0	4.3663	48.8		
25.0	4.3679	84.1		
100.0	4.3778	93.9		
196.0	4.3806	95.6		
289.0	4.3814	97.9		
361.0	4.3825	100.3		
433.0	4.3836	101.9		
458.0	4.3845	102.5		

Desorb No.	<u>1</u>	Start Date	<u>11/14/78</u>
<u>Time (hours)</u>	<u>Weight (g)</u>	<u>Capacitance (pf)</u>	
0.0	4.3845	102.5	
1.0	4.3816	102.4	
4.0	4.3812	101.8	
27.0	4.3742	101.6	
72.25	4.3719	101.1	
144.0	4.3652	86.5	
196.0	4.3635	82.8	
333.0	4.3631	91.8	
408.0	4.3626	85.0	
480.0	4.3624	84.9	

TABLE A-20. CYCLE NO. 1 EXPOSURE TO RT/50% RH ABSORB
AND RT/0% RH DESORB FOR SPECIMEN 8A

Condition:	<u>RT/50% RH</u>	Absorb;	<u>RT/0% RH</u>	Desorb
Tare	<u>0.9398 g</u>	Dry Weight	<u>3.5234 g</u>	Dry Capacitance <u>23.6 pf</u>
Specimen No.	<u>8A</u>	Absorb No.	<u>1</u>	Start Date <u>10/26/78</u>
<u>Time (hours)</u>		<u>Weight (g)</u>		<u>Capacitance (pf)</u>
0.0		4.4632		23.6
17.0		4.4646		24.4
100.0		4.4753		28.2
196.0		4.4800		28.9
289.0		4.4810		30.8
361.0		4.4819		31.1
433.0		4.4827		31.3
458.0		4.4835		31.4

Desorb No.	<u>1</u>	Start Date	<u>11/14/78</u>
<u>Time (hours)</u>		<u>Weight (g)</u>	<u>Capacitance (pf)</u>
0.0		4.4835	31.4
1.0		4.4821	31.2
4.0		4.4817	27.3
27.0		4.4814	26.9
72.25		4.4784	26.2
144.0		4.4723	25.8
196.0		4.4714	25.3
333.0		4.4698	25.3
408.0		4.4691	25.2
480.0		4.4687	25.2

TABLE A-21. CYCLE NO. 1 EXPOSURE TO RT/50% RH ABSORB
AND RT/0% RH DESORB FOR SPECIMEN 8B

Condition: <u>RT/50% RH</u>		Absorb; <u>RT/0% RH</u>		Desorb
Tare	<u>0.9430 g</u>	Dry Weight	<u>3.5377 g</u>	Dry Capacitance <u>30.7 pf</u>
Specimen No.	<u>8B</u>	Absorb No.	<u>1</u>	Start Date <u>10/26/78</u>
<u>Time (hours)</u>	<u>Weight (g)</u>	<u>Capacitance (pf)</u>		
0.0	4.4807	30.7		
1.0	4.4824	32.1		
4.0	4.4830	37.5		
25.0	4.4851	40.2		
100.0	4.4932	41.3		
196.0	4.4965	41.5		
289.0	4.4971	41.6		
361.0	4.4979	41.8		
433.0	4.4988	42.0		
458.0	4.4994	42.1		

Desorb No.	<u>1</u>	Start Date	<u>11/14/78</u>
<u>Time (hours)</u>	<u>Weight (g)</u>	<u>Capacitance (pf)</u>	
0.0	4.4994	42.1	
1.0	4.4971	42.0	
4.0	4.4969	41.9	
27.0	4.4965	41.5	
72.25	4.4933	41.3	
144.0	4.4899	40.8	
196.0	4.4882	40.3	
333.0	4.4854	39.9	
408.0	4.4850	39.5	
480.0	4.4847	39.4	

TABLE A-22. CYCLE NO. 1 EXPOSURE TO 160°F/75% RH ABSORB
AND 160°F/20% RH DESORB FOR SPECIMEN 13

Condition:	<u>160°F/75% RH</u>	Absorb;	<u>160°F/20% RH</u>	Desorb	
Tare	<u>1.1307</u> g	Dry Weight	<u>3.6791</u> g	Dry Capacitance	<u>31.6</u> pf
Specimen No.	<u>13</u>	Absorb No.	<u>1</u>	Start Date	<u>11/16/78</u>
<u>Time (hours)</u>		<u>Weight (g)</u>		<u>Capacitance (pf)</u>	
0.0		4.8098		31.6	
0.25		4.8127		32.5	
1.0		4.8168		33.8	
2.25		4.8179		43.3	
4.0		4.8191		50.6	
5.0		4.8196		57.8	
25.0		4.8105		39.1	
27.6		4.8117		42.7	
29.0		4.8123		43.4	
94.0		4.8431		42.9	

Desorb No.	<u>1</u>	Start Date	<u>11/20/78</u>
<u>Time (hours)</u>		<u>Weight (g)</u>	<u>Capacitance (pf)</u>
0.0		4.8372	37.4
0.25		4.8346	37.1
1.0		4.8305	35.1
2.25		4.8272	34.9
20.0		4.8247	34.1
24.0		4.8235	33.7
26.0		4.8220	32.6
43.0		4.8216	32.1
50.0		4.8211	31.9

TABLE A-23. CYCLE NO. 2 EXPOSURE TO 160°F/75% RH ABSORB
AND 160°F/20% RH DESORB FOR SPECIMEN 13

Condition: <u>160°F/75% RH</u> Absorb; <u>160°F/20% RH</u> Desorb		
Tare <u>1.1307</u> g	Dry Weight <u>3.6791</u> g	Dry Capacitance <u>31.6</u> pf
Specimen No. <u>13</u>	Absorb No. <u>2</u>	Start Date <u>11/27/78</u>
<u>Time (hours)</u>	<u>Weight (g)</u>	<u>Capacitance (pf)</u>
0.0	4.8108	63.4
0.25	4.8133	65.5
1.0	4.8178	68.7
2.25	4.8195	74.5
4.0	4.8210	74.8
6.25	4.8243	79.2
25.0	4.8261	82.7
27.6	4.8268	83.2
30.25	4.8277	84.1
49.0	4.8304	85.7
56.0	4.8318	86.3
72.0	4.8438	Lead broke
Desorb No. <u>2</u>		Start Date <u>-</u>
<u>Time (hours)</u>	<u>Weight (g)</u>	<u>Capacitance (pf)</u>
0.0	4.8296	-
0.25	4.8272	-
1.0	4.8259	-
2.25	4.8220	-
4.0	4.8197	-
25.0	4.8139	-
27.6	4.8133	-
95.0	4.8111	-

TABLE A-24. CYCLE NO. 1 EXPOSURE TO 160°F/75% RH ABSORB
AND 160°F/20% RH DESORB FOR SPECIMEN 17

Condition: 160°F/75% RH Absorb; 160°F/20% RH Desorb
 Tare 1.0484 g Dry Weight 3.7270 g Dry Capacitance 35.8 pf
 Specimen No. 17 Absorb No. 1 Start Date 11/16/78

<u>Time (hours)</u>	<u>Weight (g)</u>	<u>Capacitance (pf)</u>
0.0	4.7754	35.8
0.25	4.7828	53.9
1.0	4.7943	52.9
2.25	4.7952	45.6
4.0	4.7960	41.6
5.0	4.7965	44.2
25.0	4.8100	46.9
27.6	4.8108	48.2
29.0	4.8125	54.7
94.0	4.8356	55.2

Desorb No. 1 Start Date 11/20/78

<u>Time (hours)</u>	<u>Weight (g)</u>	<u>Capacitance (pf)</u>
0.0	4.8147	50.8
0.25	4.8116	50.2
1.0	4.8086	43.8
2.25	4.8057	42.0
20.0	4.7884	36.5
24.0	4.7875	36.3
26.0	4.7869	35.8
43.0	4.7863	35.3
50.0	4.7859	34.9

TABLE A-25. CYCLE NO. 2 EXPOSURE TO 160°F/75% RH ABSORB
AND 160°F/20% RH DESORB FOR SPECIMEN 17

Condition: <u>160°F/75% RH</u>		Absorb; <u>160°F/20% RH</u>		Desorb	
Tare	<u>1.0484 g</u>	Dry Weight	<u>3.7270 g</u>	Dry Capacitance	<u>35.8 pf</u>
Specimen No.	<u>17</u>	Absorb No.	<u>2</u>	Start Date	<u>11/27/78</u>
<u>Time (hours)</u>	<u>Weight (g)</u>	<u>Capacitance (pf)</u>			
0.0	4.8069	45.6			
0.25	4.8103	47.6			
1.0	4.8143	48.0			
2.25	4.8173	50.4			
4.0	4.8225	51.1			
6.25	4.8247	59.2			
25.0	4.8259	60.3			
27.60	4.8263	Shorted			
30.25	4.8269	-			
49.0	4.8298	-			
56.0	4.8309	-			
72.0	4.8326	-			
Desorb No.	<u>2</u>	Start Date <u>-</u>			
<u>Time (hours)</u>	<u>Weight (g)</u>	<u>Capacitance (pf)</u>			
0.0	4.8180	-			
0.25	4.8135	-			
1.0	4.8121	-			
2.25	4.8084	-			
4.0	4.8070	-			
25.0	4.8003	-			
27.6	4.7921	-			
95.0	4.7903	-			

TABLE A-26. CYCLE NO. 1 EXPOSURE TO 160°F/75% RH ABSORB AND 160°F/20% RH DESORB FOR SPECIMEN 21

Condition: 160°F/75% RH Absorb; 160°F/20% RH Desorb

Tare 1.1101 g Dry Weight 3.5070 g Dry Capacitance 46.8 pf

Specimen No. 21 Absorb No. 1 Start Date 11/16/78

<u>Time (hours)</u>	<u>Weight (g)</u>	<u>Capacitance (pf)</u>
0.0	4.6171	46.8
0.25	4.6360	56.3
1.0	4.6449	60.6
2.25	4.6454	62.3
4.0	4.6459	64.1
5.0	4.6463	65.3
25.0	4.6702	70.1
27.6	4.6713	79.4
29.0	4.6720	83.1
94.0	4.6749	83.9

Desorb No. 1 Start Date 11/20/78

<u>Time (hours)</u>	<u>Weight (g)</u>	<u>Capacitance (pf)</u>
0.0	4.6464	42.4
0.25	4.6442	40.2
1.0	4.6343	39.4
2.25	4.6335	39.2
20.0	4.6284	36.4
24.0	4.6268	36.0
26.0	4.6259	35.9
43.0	4.6254	35.6
50.0	4.6251	35.4

TABLE A-27. CYCLE NO. 2 EXPOSURE TO 160°F/75% RH ABSORB
AND 160°F/20% RH DESORB FOR SPECIMEN 21

Condition: <u>160°F/75% RH</u>		Absorb; <u>160°F/20% RH</u>		Desorb	
Tare	<u>1.1101</u> g	Dry Weight	<u>3.5070</u> g	Dry Capacitance	<u>46.8</u> pf
Specimen No.	<u>21</u>	Absorb No.	<u>2</u>	Start Date	<u>11/27/78</u>
<u>Time (hours)</u>	<u>Weight (g)</u>	<u>Capacitance (pf)</u>			
0.0	4.6606	49.8			
0.25	4.6622	54.8			
1.0	4.6679	58.8			
2.25	4.6691	60.9			
4.0	4.6705	61.3			
6.25	4.6729	61.7			
25.0	4.6741	62.1			
27.6	4.6746	63.4			
30.25	4.6751	63.6			
49.0	4.6767	94.1			
56.0	4.6775	96.3			
72.0	4.6794	98.2			
Desorb No.	<u>2</u>	Start Date <u>-</u>			
<u>Time (hours)</u>	<u>Weight (g)</u>	<u>Capacitance (pf)</u>			
0.0	4.6480	86.2			
0.25	4.6472	84.6			
1.0	4.6459	81.1			
2.25	4.6422	79.7			
4.0	4.6409	73.8			
25.0	4.6359	69.4			
27.6	4.6351	61.2			
95.0	4.6331	58.0			

TABLE A-28. CYCLE NO. 1 EXPOSURE TO 160°F/98% RH ABSORB
AND 160°F/0% RH DESORB FOR SPECIMEN 29

Condition: 160°F/98% RH Absorb; 160°F/0% RH Desorb

Tare 3.5404 g Dry Weight 3.5144 g Dry Capacitance 30.5 pf

Specimen No. 29 Absorb No. 1 Start Date 12/7/78

<u>Time (hours)</u>	<u>Weight (g)</u>	<u>Capacitance (pf)</u>
0.0	7.0548	30.5
1.0	7.1870	62.4
4.0	7.1791	94.3
22.0	7.3256	136.2
25.0	7.3288	138.2
27.6	-	140.8
93.0	-	191.8

Desorb No. 1 Start Date 12/11/78

<u>Time (hours)</u>	<u>Weight (g)</u>	<u>Capacitance (pf)</u>
0.0	7.1322	144.8
1.0	7.1096	126.4
4.0	7.0863	121.6
6.25	7.0787	114.2
25.0	7.0642	63.2
27.6	7.0633	52.8
30.25	7.0623	50.4
49.0	7.0596	43.0
55.0	7.0593	41.9
96.0	7.0543	40.3

TABLE A-29. CYCLE NO. 2 EXPOSURE TO 160°F/98% RH ABSORB
AND 160°F/0% RH DESORB FOR SPECIMEN 29

Condition: <u>160°F/98% RH</u>		Absorb; <u>160°F/0% RH</u>		Desorb
Tare <u>3.5404</u> g	Dry Weight <u>3.5144</u> g	Dry Capacitance <u>30.5</u> pf		
Specimen No. <u>29</u>	Absorb No. <u>2</u>	Start Date <u>12/15/78</u>		
<u>Time (hours)</u>	<u>Weight (g)</u>	<u>Capacitance (pf)</u>		
0.0	7.0543	40.3		
1.0	7.1428	Off Scale		
4.0	7.1950	Off Scale		
6.25	7.1994	Off Scale		
71.0	7.2251	Off Scale		

Desorb No. 2

Start Date 12/18/78

<u>Time (hours)</u>	<u>Weight (g)</u>	<u>Capacitance (pf)</u>
0.0	7.1739	Off Scale
1.0	7.1360	Off Scale
4.0	7.1016	Off Scale
6.25	7.0964	Off Scale
25.0	7.0686	55.2
27.6	7.0652	52.0
30.25	7.0643	50.7
49.0	7.0631	41.9
55.0	7.0618	40.7
72.0	7.0591	38.5
78.25	7.0585	36.1

TABLE A-30. CYCLE NO. 1 EXPOSURE TO 160°F/98% RH ABSORB
AND 160°F/0% RH DESORB FOR SPECIMEN 31

Condition:	<u>160°F/98% RH</u>	Absorb;	<u>160°F/0% RH</u>	Desorb
Tare	<u>3.4287 g</u>	Dry Weight	<u>3.4921 g</u>	Dry Capacitance <u>31.7 pf</u>
Specimen No.	<u>31</u>	Absorb No.	<u>1</u>	Start Date <u>12/7/78</u>
<u>Time (hours)</u>		<u>Weight (g)</u>		<u>Capacitance (pf)</u>
0.0		6.9208		31.7
1.0		7.0378		50.3
4.0		7.0197		71.0
22.0		7.1020		115.5
25.0		7.1584		148.1
27.25		-		157.2
93.0		-		163.4

Desorb No.	<u>1</u>	Start Date	<u>12/11/78</u>
<u>Time (hours)</u>		<u>Weight (g)</u>	<u>Capacitance (pf)</u>
0.0		6.9655	98.3
1.0		6.9524	72.0
4.0		6.9406	67.1
6.25		6.9371	56.3
25.0		6.9238	47.5
27.6		6.9232	41.3
30.25		6.9227	40.2
49.0		6.9220	39.4
55.0		6.9218	36.1
96.0		6.9211	32.6

TABLE A-31. CYCLE NO. 2 EXPOSURE TO 160°F/98% RH ABSORB
AND 160°F/0% RH DESORB FOR SPECIMEN 31

Condition:	<u>160°F/98% RH</u>	Absorb;	<u>160°F/0% RH</u>	Desorb
Tare	<u>3.4287</u> g	Dry Weight	<u>3.4921</u> g	Dry Capacitance <u>31.7</u> pf
Specimen No.	<u>31</u>	Absorb No.	<u>2</u>	Start Date <u>12/15/78</u>
<u>Time (hours)</u>		<u>Weight (g)</u>		<u>Capacitance (pf)</u>
0.0		6.9211		32.6
1.0		7.0230		68.8
4.0		7.0640		107.5
6.25		7.0687		108.3
71.0		7.1305		167.1

Desorb No.	<u>2</u>	Start Date	<u>12/18/78</u>
<u>Time (hours)</u>		<u>Weight (g)</u>	<u>Capacitance (pf)</u>
0.0		7.0400	130.2
1.0		7.0025	109.6
4.0		6.9844	63.3
6.25		6.9786	61.0
25.0		6.9587	42.6
27.6		6.9575	36.4
30.25		6.9562	35.8
49.0		6.9505	33.9
55.0		6.9473	32.6
72.0		6.9426	31.9
78.25		6.9419	31.7

TABLE A-32. CYCLE NO. 1 EXPOSURE TO 160°F/98% RH ABSORB
AND 160°F/50% RH DESORB FOR SPECIMEN 32

Condition: 160°F/98% RH Absorb; 160°F/50% RH Desorb

Tare 3.4288 g Dry Weight 3.6352 g Dry Capacitance 58.2 pf

Specimen No. 32 Absorb No. 1 Start Date 12/7/78

<u>Time (hours)</u>	<u>Weight (g)</u>	<u>Capacitance (pf)</u>
0.0	7.0640	58.2
1.0	7.1788	70.1
4.0	7.1637	104.5
22.0	7.2343	162.6
25.0	7.3123	224.0
27.6	-	1342.0
93.0	-	1455.0
Fan on humidity chamber broke; restarted Absorb 12/15/78.		
0.0	7.1026	68.5
1.0	7.2168	136.8
4.0	7.2345	Off Scale
6.25	7.2397	Off Scale
71.0	7.2597	Off Scale

Desorb No. 1 Start Date 12/18/78

<u>Time (hours)</u>	<u>Weight (g)</u>	<u>Capacitance (pf)</u>
0.0	7.1194	535.0
1.0	7.0980	331.0
4.0	7.0874	324.0
6.0	7.0851	Off Scale
25.0	7.0842	Off Scale
27.6	7.0839	221.0
30.0	7.0837	218.0
49.0	7.0836	218.0
55.0	7.0835	217.0
72.0	7.0833	Off Scale

TABLE A-33. CYCLE NO. 1 EXPOSURE TO 160°F/98% RH ABSORB
AND 160°F/50% RH DESORB FOR SPECIMEN 33

Condition: <u>160°F/98% RH</u> Absorb;		<u>160°F/50% RH</u> Desorb	
Tare <u>3.4164</u> g	Dry Weight <u>3.6644</u> g	Dry Capacitance <u>34.5</u> pf	
Specimen No. <u>33</u>	Absorb No. <u>i</u>	Start Date <u>12/7/78</u>	
<u>Time (hours)</u>	<u>Weight (g)</u>	<u>Capacitance (pf)</u>	
0.0	7.0808	34.5	
1.0	7.1814	47.6	
4.0	7.1548	79.9	
22.0	7.2438	97.4	
25.0	7.3268	98.2	
27.5	-	115.4	
93.0	-	192.6	
Fan on humidity chamber broke; restarted Absorb 12/15/78.			
0.0	7.1211	50.6	
1.0	7.1789	119.4	
4.0	7.2450	Off Scale	
6.25	7.2484	Off Scale	
71.0	7.2659	Off Scale	

Desorb No. <u>1</u>	Start Date <u>12/18/78</u>	
<u>Time (hours)</u>	<u>Weight (g)</u>	<u>Capacitance (pf)</u>
0.0	7.1253	Off Scale
1.0	7.0984	Off Scale
4.0	7.0887	Off Scale
6.0	7.0868	Off Scale
25.0	7.0861	68.5
27.6	7.0854	68.1
30.0	7.0850	67.9
49.0	7.0848	93.7
55.0	7.0848	69.2
72.0	7.0846	66.2

TABLE A-34. CYCLE NO. 1 EXPOSURE TO 160°F/50% RH ABSORB
AND 160°F/0% RH DESORB FOR SPECIMEN 30

Condition: <u>160°F/50% RH</u> Absorb;		<u>160°F/0% RH</u> Desorb	
Tare <u>3.4720</u> g	Dry Weight <u>3.6609</u> g	Dry Capacitance <u>68.9</u> pf	
Specimen No. <u>30</u>	Absorb No. <u>1</u>	Start Date <u>12/18/78</u>	
<u>Time (hours)</u>	<u>Weight (g)</u>	<u>Capacitance (pf)</u>	
0.0	7.1329	68.9	
1.0	7.1456	108.7	
4.0	7.1520	114.3	
6.0	7.1590	115.4	
25.0	7.1651	116.8	
27.6	7.1659	119.3	
30.0	7.1667	121.1	
47.0	7.1678	123.2	

Desorb No. <u>1</u>		Start Date <u>12/20/78</u>
<u>Time (hours)</u>	<u>Weight (g)</u>	<u>Capacitance (pf)</u>
0.0	7.1526	95.3
1.0	7.1461	88.4
4.0	7.1417	83.0
6.25	7.1371	74.2
25.0	7.1332	71.3
27.6	7.1323	70.9
30.25	7.1318	69.6
49.0	7.1316	67.8

TABLE A-35. CYCLE NO. 1 EXPOSURE TO 160°F/50% RH ABSORB
AND 160°F/0% RH DESORB FOR SPECIMEN 35

Condition: 160°F/50% RH Absorb; 160°F/0% RH Desorb
Tare 3.5692 g Dry Weight 3.6186 g Dry Capacitance 54.7 pf
Specimen No. 35 Absorb No. 1 Start Date 12/18/78

<u>Time (hours)</u>	<u>Weight (g)</u>	<u>Capacitance (pf)</u>
0.0	7.1878	54.7
1.0	7.1934	64.9
4.0	7.1973	65.4
6.0	7.2041	66.7
25.0	7.2178	67.5
27.6	7.2184	68.3
30.0	7.2192	70.1
47.0	7.2199	71.6

Desorb No. 1 Start Date 12/20/78

<u>Time (hours)</u>	<u>Weight (g)</u>	<u>Capacitance (pf)</u>
0.0	7.2097	64.7
1.0	7.2053	58.8
4.0	7.2001	57.9
6.25	7.1978	56.3
25.0	7.1931	54.5
27.6	7.1917	53.7
30.25	7.1911	52.8
49.0	7.1899	51.2

TABLE A-36. CYCLE NO. 1 EXPOSURE TO RT/93% RH ABSORB
AND RT/0% RH DESORB FOR SPECIMEN AFD

Condition: <u>RT/93% RH</u>		Absorb; <u>RT/0% RH</u>		Desorb	
Tare <u>3.3107</u> g	Dry Weight <u>6.6936</u> g	Dry Capacitance <u>20.2, 19.5</u> pf		#1	#2
Specimen No. <u>AFD</u>	Absorb No. <u>1</u>	Start Date <u>2/12/79</u>			
<u>Time (Days)</u>	<u>Weight (g)</u>	<u>Capacitance (pf)</u>			
		<u>Sensor #1</u>	<u>Sensor #2</u>		
0.00	10.0043	20.6	20.5		
0.25	10.0255	20.2	19.5		
1.00	10.0427	21.1	20.3		
2.25	10.0566	21.3	20.6		
4.00	10.0714	21.9	21.2		
8.00	10.0816	22.9	22.4		
11.25	10.0878	23.1	22.7		
14.00	10.0884	23.6	23.0		
18.00	10.0896	23.7	23.1		
21.00	10.0911	23.9	23.3		

Desorb No. <u>1</u>		Start Date <u>3/5/79</u>	
<u>Time (Days)</u>	<u>Weight (g)</u>	<u>Capacitance (pf)</u>	
		<u>Sensor #1</u>	<u>Sensor #2</u>
0.00	10.0911	23.9	23.3
0.25	10.0726	23.7	23.1
1.00	10.0560	23.1	22.5
2.25	10.0434	22.4	22.1
4.00	10.0322	21.3	20.8
7.00	10.0210	20.9	20.4
9.00	10.0190	20.6	20.0
11.00	10.0175	20.4	19.8
16.00	10.0159	20.4	19.8
18.00	10.0130	20.4	19.8
21.00	10.0091	20.3	19.6

TABLE A-37. CYCLE NO. 2 EXPOSURE TO RT/93% RH ABSORB
AND RT/0% RH DESORB FOR SPECIMEN AFD

Condition: <u>RT/93% RH</u>		Absorb; <u>RT/0% RH</u>		Desorb	
Tare <u>3.3107</u> g		Dry Weight <u>6.6936</u> g		Dry Capacitance <u>20.2, 19.5</u> pf	
Specimen No. <u>AFD</u>		Absorb No. <u>2</u>		Start Date <u>3/26/79</u>	
<u>Time (Days)</u>	<u>Weight (g)</u>	<u>Capacitance (pf)</u>			
		<u>Sensor # 1</u>	<u>Sensor # 2</u>		
0.00	10.0091	20.3	19.6		
0.25	10.0304	20.5	19.8		
1.00	10.0471	20.6	19.9		
2.25	10.0627	21.3	20.6		
4.00	10.0764	21.8	21.1		
7.00	10.0894	23.3	22.7		
9.00	10.0926	23.8	23.5		
11.25	10.0930	24.0	23.6		
16.00	10.0949	24.1	23.6		
22.00	10.0956	24.1	23.6		

Desorb No. <u>2</u>		Start Date <u>4/16/79</u>	
<u>Time (Days)</u>	<u>Weight (g)</u>	<u>Capacitance (pf)</u>	
		<u>Sensor # 1</u>	<u>Sensor # 2</u>
0.00	10.0956	24.1	23.6
0.25	10.0710	23.5	23.0
1.00	10.0577	23.0	22.5
2.25	10.0436	22.4	21.8
6.25	10.0261	21.1	20.6
9.00	10.0211	20.8	20.3
13.00	10.0162	20.5	19.9
16.00	10.0153	20.3	19.7
21.00	10.0140	20.0	19.4
24.00	10.0140	20.0	19.4

TABLE A-38. CYCLE NO. 1 EXPOSURE TO RT/93% RH ABSORB
AND RT/0% RH DESORB FOR SPECIMEN BFD

Condition: RT/93% RH Absorb; RT/0% RH Desorb #3 #4
Tare 3.3333 g Dry Weight 6.9330 g Dry Capacitance 21.1, 21.9 pf
Specimen No. BFD Absorb No. 1 Start Date 2/12/79
Time (Days) Weight (g) Capacitance (pf)
Sensor #3 Sensor #4

0.00	10.2663	22.1	23.3
0.25	10.2879	21.1	21.9
1.00	10.3054	21.9	22.7
2.25	10.3194	22.3	23.3
4.00	10.3349	22.7	23.9
8.00	10.3441	23.3	24.7
11.25	10.3503	23.8	25.1
14.00	10.3508	24.6	26.2
18.00	10.3522	24.7	26.3
21.00	10.3536	25.0	26.5

Desorb No. 1 Start Date 3/5/79
Time (Days) Weight (g) Capacitance (pf)
Sensor #3 Sensor #4

0.00	10.3536	25.0	26.5
0.25	10.3352	24.9	26.3
1.00	10.3184	24.3	25.7
2.25	10.3062	23.9	25.2
4.00	10.2948	22.7	23.9
7.00	10.2829	22.4	23.5
9.00	10.2803	21.8	22.9
11.00	10.2778	21.2	22.3
16.00	10.2764	21.2	22.3
18.00	10.2743	21.2	22.1
21.00	10.2707	21.2	22.1

TABLE A-39. CYCLE NO. 2 EXPOSURE TO RT/93% RH ABSORB AND RT/0% RH DESORB FOR SPECIMEN BFD

Condition: <u>RT/93% RH</u>		Absorb; <u>RT/0% RH</u>		Desorb	
Tare	<u>3.3333 g</u>	Dry Weight	<u>6.9330 g</u>	Dry Capacitance	<u>21.1, 21.9 pf</u>
Specimen No.	<u>BFD</u>	Absorb No.	<u>2</u>	Start Date	<u>3/26/79</u>
<u>Time (Days)</u>	<u>Weight (g)</u>	<u>Capacitance (pf)</u>			
		<u>Sensor #3</u>	<u>Sensor #4</u>		
0.00	10.2707	21.2	22.1		
0.25	10.2922	21.4	22.4		
1.00	10.3090	21.7	22.7		
2.25	10.3246	22.3	23.5		
4.00	10.3396	22.7	23.9		
7.00	10.3531	24.2	25.5		
9.00	10.3564	24.7	26.0		
11.25	10.3568	25.1	26.3		
16.00	10.3589	25.1	26.4		
22.00	10.3596	25.4	26.7		

Desorb No. <u>2</u>		Start Date <u>4/16/79</u>	
<u>Time (Days)</u>	<u>Weight (g)</u>	<u>Capacitance (pf)</u>	
		<u>Sensor #3</u>	<u>Sensor #4</u>
0.00	10.3596	25.4	26.7
0.25	10.3342	24.9	26.1
1.00	10.3213	24.3	25.6
2.25	10.3070	23.6	24.9
6.25	10.2899	22.4	23.6
9.00	10.2845	22.1	23.4
13.00	10.2790	21.7	23.0
16.00	10.2783	21.5	22.7
21.00	10.2771	21.2	22.4
24.00	10.2771	21.2	22.3

TABLE A-40. CYCLE NO. 1 EXPOSURE TO RT/93% RH ABSORB
AND RT/0% RH DESORB FOR SPECIMEN CFD

Condition: <u>RT/93% RH</u>		Absorb; <u>RT/0% RH</u>		Desorb	
Tare	<u>3.3893 g</u>	Dry Weight	<u>6.9691 g</u>	Dry Capacitance <u>32.9^{#5}, 18.7^{#6} pf</u>	
Specimen No.	<u>CFD</u>	Absorb No.	<u>1</u>	Start Date <u>2/12/79</u>	
<u>Time (Days)</u>	<u>Weight (g)</u>	<u>Capacitance (pf)</u>			
		<u>Sensor #5*</u>	<u>Sensor #6</u>		
0.00	10.3584	32.9	18.7		
0.25	10.3766	33.5	18.9		
1.00	10.3952	34.5	20.1		
2.25	10.4094	35.5	20.4		
4.00	10.4263	42.8	20.5		
8.00	10.4361	43.1	21.3		
11.25	10.4423	43.3	21.5		
14.00	10.4429	44.9	22.9		
18.00	10.4442	45.0	22.9		
21.00	10.4456	45.3	23.1		

*The initial readings on this sensor were believed to be erratic signifying a possible bad sensor.

Desorb No.	<u>1</u>	Start Date	<u>3/5/79</u>
<u>Time (Days)</u>	<u>Weight (g)</u>	<u>Capacitance (pf)</u>	
		<u>Sensor #5</u>	<u>Sensor #6</u>
0.00	10.4456	45.3	23.1
0.25	10.4265	45.1	22.9
1.00	10.4104	44.5	22.3
2.25	10.3983	43.8	21.7
4.00	10.3869	42.3	20.4
7.00	10.3755	41.8	19.9
9.00	10.3727	35.3	19.7
11.00	10.3702	34.1	19.2
16.00	10.3685	32.4	19.2
18.00	10.3667	32.3	19.1
21.00	10.3627	32.3	19.1

TABLE A-41. CYCLE NO. 2 EXPOSURE TO RT/93% RH ABSORB
AND RT/0% RH DESORB FOR SPECIMEN CFD

Condition:	<u>RT/93% RH</u>	Absorb;	<u>RT/0% RH</u>	Desorb
Tare	<u>3.3893 g</u>	Dry Weight	<u>6.9641 g</u>	Dry Capacitance <u>32.9, 18.7</u> pf
Specimen No.	<u>CFD</u>	Absorb No.	<u>2</u>	Start Date <u>3/26/79</u>
<u>Time (Days)</u>		<u>Weight (g)</u>		<u>Capacitance (pf)</u>
				<u>Sensor #5</u> <u>Sensor #6</u>
0.00		10.3627		32.3 19.1
0.25		10.3845		33.1 19.3
1.00		10.4015		33.4 19.4
2.25		10.4204		35.2 20.3
4.00		10.4344		35.5 20.6
7.00		10.4457		37.7 21.7
9.00		10.4493		38.2 22.3
11.25		10.4497		38.9 22.9
16.00		10.4518		38.9 22.9
22.00		10.4524		40.2 23.0

Desorb No.	<u>2</u>	Start Date	<u>4/16/79</u>
<u>Time (Days)</u>		<u>Weight (g)</u>	<u>Capacitance (pf)</u>
			<u>Sensor #5</u> <u>Sensor #6</u>
0.00		10.4524	40.2 23.0
0.25		10.4272	38.5 22.6
1.00		10.4139	37.3 21.6
2.25		10.3997	36.7 20.9
6.25		10.3826	34.2 20.2
9.00		10.3775	33.9 19.9
13.00		10.3721	33.6 19.6
16.00		10.3712	33.4 19.4
21.00		10.3698	33.1 19.1
24.00		10.3697	33.1 19.1

TABLE A-42. CYCLE NO. 1 EXPOSURE TO RT/75% RH ABSORB
AND RT/0% RH DESORB FOR SPECIMEN DFD

Condition: <u>RT/75% RH</u> Absorb; <u>RT/0% RH</u> Desorb			
Tare <u>3.3677</u> g	Dry Weight <u>6.6699</u> g	Dry Capacitance <u>17.8, 19.7</u> pf	
Specimen No. <u>DFD</u>	Absorb No. <u>1</u>	Start Date <u>2/12/79</u>	
<u>Time (Days)</u>	<u>Weight (g)</u>	<u>Capacitance (pf)</u>	
		<u>Sensor #7</u>	<u>Sensor #8</u>
0.00	10.0376	17.8	19.7
0.25	10.0544	17.8	19.8
1.00	10.0656	18.3	20.6
2.25	10.0779	18.7	20.7
4.00	10.0902	18.9	21.0
8.00	10.0969	19.2	21.4
11.25	10.1029	19.8	22.0
14.00	10.1032	20.3	22.9
18.00	10.1035	20.3	22.9
21.00	10.1038	20.6	23.1

Desorb No. <u>1</u>		Start Date <u>3/5/79</u>	
<u>Time (Days)</u>	<u>Weight (g)</u>	<u>Capacitance (pf)</u>	
		<u>Sensor #7</u>	<u>Sensor #8</u>
0.00	10.1038	20.6	23.1
0.25	10.0907	20.6	23.1
1.00	10.0793	20.2	22.7
2.25	10.0700	19.9	22.4
4.00	10.0604	19.4	21.9
7.00	10.0520	18.6	20.8
9.00	10.0501	18.6	20.8
11.00	10.0482	18.2	20.5
16.00	10.0478	18.2	20.5
18.00	10.0459	18.2	20.4
21.00	10.0406	18.2	20.4

TABLE A-43. CYCLE NO. 2 EXPOSURE TO RT/75% RH ABSORB AND RT/0% RH DESORB FOR SPECIMEN DFD

Condition: <u>RT/75% RH</u> Absorb;		<u>RT/0% RH</u> Desorb		
Tare <u>3.3677</u> g	Dry Weight <u>6.6699</u> g	Dry Capacitance <u>17.8, 19.7</u> pf		
Specimen No. <u>DFD</u>	Absorb No. <u>2</u>	Start Date <u>3/26/79</u>		
<u>Time (Days)</u>	<u>Weight (g)</u>	<u>Capacitance (pf)</u>		
		<u>Sensor #7</u>	<u>Sensor #8</u>	
0.00	10.0406	18.2	20.4	
0.25	10.0556	18.2	20.4	
1.00	10.0684	18.4	Lead Broke	
2.25	10.0809	18.5		
4.00	10.0916	18.9		
7.00	10.1023	19.9		
9.00	10.1055	20.2		
11.25	10.1058	20.5		
16.00	10.1075	20.5		
22.00	10.1076	20.5		Lead Broke

Desorb No. <u>2</u>		Start Date <u>4/16/79</u>		
<u>Time (Days)</u>	<u>Weight (g)</u>	<u>Capacitance (pf)</u>		
		<u>Sensor #7</u>	<u>Sensor #8</u>	
0.00	10.1076	20.5	Lead Broke	
0.25	10.0910	20.3		
1.00	10.0832	20.0		
2.25	10.0725	19.6		
6.25	10.0559	18.9		
9.00	10.0545	18.7		
13.00	10.0491	18.4		
16.00	10.0487	18.3		
21.00	10.0472	18.0		
24.00	10.0472	18.0		Lead Broke

TABLE A-44. CYCLE NO. 1 EXPOSURE TO RT/75% RH ABSORB
AND RT/0% RH DESORB FOR SPECIMEN EFD

Condition: <u>RT/75% RH</u>		Absorb; <u>RT/0% RH</u>		Desorb	
Tare	<u>3.1688</u> g	Dry Weight	<u>6.9285</u> g	Dry Capacitance	<u>16.4, 18.3</u> pf
Specimen No.	<u>EFD</u>	Absorb No.	<u>1</u>	Start Date	<u>2/12/79</u>
<u>Time (Days)</u>	<u>Weight (g)</u>	<u>Capacitance (pf)</u>			
		<u>Sensor #9</u>	<u>Sensor #10</u>		
0.00	10.0973	16.4	18.3		
0.25	10.1123	16.7	18.5		
1.00	10.1236	16.9	18.9		
2.25	10.1363	17.3	19.0		
4.00	10.1509	17.5	19.3		
8.00	10.1575	17.9	19.8		
11.25	10.1644	18.2	20.1		
14.00	10.1651	18.8	20.6		
18.00	10.1652	18.9	20.6		
21.00	10.1653	19.0	20.7		

Desorb No.	<u>1</u>	Start Date	<u>3/5/79</u>
<u>Time (Days)</u>	<u>Weight (g)</u>	<u>Capacitance (pf)</u>	
		<u>Sensor #9</u>	<u>Sensor #10</u>
0.00	10.1653	19.0	20.7
0.25	10.1526	19.0	20.6
1.00	10.1413	18.5	20.1
2.25	10.1303	18.3	19.8
4.00	10.1212	17.8	19.2
7.00	10.1127	17.0	18.4
9.00	10.1100	17.0	18.4
11.00	10.1080	16.7	18.2
16.00	10.1077	16.7	18.2
18.00	10.1058	16.7	18.2
21.00	10.1006	16.7	18.2

TABLE A-45. CYCLE NO. 2 EXPOSURE TO RT/75% RH ABSORB
AND RT/0% RH DESORB FOR SPECIMEN EFD

Condition: <u>RT/75% RH</u>		Absorb; <u>RT/0% RH</u>		Desorb	
Tare <u>3.1688</u> g	Dry Weight <u>6.9285</u> g	Dry Capacitance <u>16.4, 18.3</u> pf		#9	#10
Specimen No. <u>EFD</u>	Absorb No. <u>2</u>	Start Date <u>3/26/79</u>			
<u>Time (Days)</u>	<u>Weight (g)</u>	<u>Capacitance (pf)</u>			
		<u>Sensor #9</u>	<u>Sensor #10</u>		
0.00	10.1006	16.7	18.2		
0.25	10.1160	16.8	18.3		
1.00	10.1286	16.9	18.4		
2.25	10.1421	17.2	18.7		
4.00	10.1530	17.6	19.2		
7.00	10.1633	18.7	20.4		
9.00	10.1665	18.9	20.7		
11.25	10.1669	19.2	21.0		
16.00	10.1684	19.2	21.0		
22.00	10.1686	19.2	21.0		

Desorb No. <u>2</u>		Start Date <u>4/16/79</u>	
<u>Time (Days)</u>	<u>Weight (g)</u>	<u>Capacitance (pf)</u>	
		<u>Sensor #9</u>	<u>Sensor #10</u>
0.00	10.1686	19.2	21.0
0.25	10.1528	18.6	20.7
1.00	10.1436	18.2	20.3
2.25	10.1331	17.8	19.9
6.25	10.1170	17.1	19.1
9.00	10.1157	16.9	18.9
13.00	10.1100	16.7	18.7
16.00	10.1096	16.6	18.6
21.00	10.1083	16.3	18.3
24.00	10.1083	16.3	18.3

TABLE A-46. CYCLE NO. 1 EXPOSURE TO RT/75% RH ABSORB AND RT/0% RH DESORB FOR SPECIMEN FFD

Condition: <u>RT/75% RH</u>		Absorb; <u>RT/0% RH</u>		Desorb	
Tare	<u>3.3659</u> g	Dry Weight	<u>6.765</u> g	Dry Capacitance	<u>21.7, 21.5</u> pf
Specimen No.	<u>FFD</u>	Absorb No.	<u>1</u>	Start Date	<u>2/12/79</u>
<u>Time (Days)</u>	<u>Weight (g)</u>	<u>Capacitance (pf)</u>			
		<u>Sensor #11</u>	<u>Sensor #12</u>		
0.00	10.1309	21.7	21.5		
0.25	10.1459	21.7	21.6		
1.00	10.1574	22.2	21.5		
2.25	10.1699	22.3	22.0		
4.00	10.1826	22.8	22.3		
8.00	10.1891	23.4	22.8		
11.25	10.1960	23.8	23.3		
14.00	10.1968	24.6	24.5		
18.00	10.1969	24.6	24.5		
21.00	10.1970	24.7	24.6		

Desorb No.	<u>1</u>	Start Date	<u>3/5/79</u>	
<u>Time (Days)</u>	<u>Weight (g)</u>	<u>Capacitance (pf)</u>		
		<u>Sensor #11</u>	<u>Sensor #12</u>	
0.00	10.1970	24.7	24.6	
0.25	10.1841	24.7	24.6	
1.00	10.1730	24.3	24.2	
2.25	10.1624	24.1	23.9	
4.00	10.1533	23.6	23.4	
7.00	10.1453	22.7	22.4	
9.00	10.1424	22.4	21.9	
11.00	10.1398	22.1	21.5	
16.00	10.1395	22.1	21.4	
18.00	10.1374	22.1	21.5	
21.00	10.1323	22.1	21.5	

TABLE A-47. CYCLE NO. 2 EXPOSURE TO RT/75% RH ABSORB
AND RT/0% RH DESORB FOR SPECIMEN FFD

Condition: <u>RT/75% RH</u>		Absorb; <u>RT/0% RH</u>		Desorb	
Tare <u>3.3659</u> g	Dry Weight	<u>6.765</u> g	Dry Capacitance	<u>21.7</u> , <u>21.5</u> pf	^{#11} ^{#12}
Specimen No. <u>FFD</u>	Absorb No. <u>2</u>	Start Date <u>3/26/79</u>			
<u>Time (Days)</u>	<u>Weight (g)</u>	<u>Capacitance (pf)</u>			
		<u>Sensor #11</u>	<u>Sensor #12</u>		
0.00	10.1323	22.1	21.5		
0.25	10.1476	22.1	21.5		
1.00	10.1606	22.1	21.6		
2.25	10.1737	22.4	22.0		
4.00	10.1848	22.9	22.5		
7.00	10.1949	24.3	23.8		
9.00	10.1979	24.7	24.1		
11.25	10.1982	25.0	24.5		
16.00	10.1999	25.0	24.5		
22.00	10.2000	25.0	24.5		

Desorb No. <u>2</u>	Start Date <u>4/16/79</u>		
<u>Time (Days)</u>	<u>Weight (g)</u>	<u>Capacitance (pf)</u>	
		<u>Sensor #11</u>	<u>Sensor #12</u>
0.00	10.2000	25.0	24.5
0.25	10.1837	24.7	23.9
1.00	10.1749	24.3	23.5
2.25	10.1644	23.9	23.0
6.25	10.1474	23.1	22.3
9.00	10.1465	22.9	22.1
13.00	10.1408	22.6	21.8
16.00	10.1405	22.4	21.7
21.00	10.1390	22.0	21.3
24.00	10.1390	22.0	21.3

TABLE A-48. CYCLE NO. 1 EXPOSURE TO 120°F/75% RH ABSORB AND 120°F/0% RH DESORB FOR SPECIMEN GFD

Condition: <u>120°F/75% RH</u> Absorb;		<u>120°F/0% RH</u> Desorb	
Tare <u>9.3327</u> g	Dry Weight <u>6.8272</u> g	Dry Capacitance <u>39.7</u> , <u>39.3</u> pf ^{#13, #14}	
Specimen No. <u>GFD</u>	Absorb No. <u>1</u>	Start Date <u>2/21/79</u>	
<u>Time (Days)</u>	<u>Weight (g)</u>	<u>Capacitance (pf)</u>	
		<u>Sensor #13</u>	<u>Sensor #14</u>
0.00	16.1642	39.7	39.3
3 min. @ 120 with Fan On	16.1723	41.6	41.0
0.1 Day @ Dewpoint - Fan On	16.2087	42.1	41.7
0.1 Day @ Dewpoint - Fan Off	16.1866	42.3	41.8
0.25 - Fan On	16.2143	42.5	42.0
0.25 - Fan Off	16.1955	42.6	42.2
1.00 - Fan On	16.2217	44.7	45.1
1.00 - Fan Off	16.2171	42.9	43.5
1.25	16.2241	43.0	43.5
2.00	16.2301	43.3	43.7
2.25	16.2305	43.4	43.7
5.00	16.2312	44.1	44.4
6.00	16.2318	44.4	44.6
7.00 - Fan Off	16.2323	44.5	44.7

Desorb No. <u>1</u>	Start Date <u>2/28/79</u>		
<u>Time (Days)</u>	<u>Weight (g)</u>	<u>Capacitance (pf)</u>	
		<u>Sensor #13</u>	<u>Sensor #14</u>
0.00	16.2323	44.5	44.7
0.25	16.1908	43.7	43.1
1.00	16.1739	42.2	42.0
1.25	16.1728	42.1	41.8
2.00	16.1669	41.5	41.3
5.00	16.1622	40.9	40.7
6.00	16.1604	40.6	40.4
7.00	16.1559	40.6	40.4

TABLE A-49. CYCLE NO. 2 EXPOSURE TO 120°F/75% RH ABSORB
AND 120°F/0% RH DESORB FOR SPECIMEN GFD

Condition: <u>120°F/75% RH</u> Absorb; <u>120°F/0% RH</u> Desorb			
Tare <u>9.3327</u> g	Dry Weight <u>6.8272</u> g	Dry Capacitance <u>39.7</u> , <u>39.3</u> pf	#13 #14
Specimen No. <u>GFD</u>	Absorb No. <u>2</u>	Start Date <u>3/7/79</u>	
<u>Time (Days)</u>	<u>Weight (g)</u>	<u>Capacitance (pf)</u>	
		<u>Sensor #13</u>	<u>Sensor #14</u>
0.00	16.1599	40.6	40.4
0.25	16.1984	43.1	42.7
1.00	16.2174	43.9	43.4
1.25	16.2221	44.2	43.6
2.00	16.2247	44.7	44.2
2.25	16.2248	44.7	44.2
5.00	16.2294	44.9	44.5
7.00	16.2305	45.2	44.8

Desorb No. <u>2</u>		Start Date <u>3/14/79</u>	
<u>Time (Days)</u>	<u>Weight (g)</u>	<u>Capacitance (pf)</u>	
		<u>Sensor #13</u>	<u>Sensor #14</u>
0.00	16.2305	45.2	44.8
0.25	16.2018	44.4	43.6
1.00	16.1821	43.1	42.2
1.25	16.1800	42.7	41.8
2.00	16.1704	41.9	41.1
5.00	16.1664	41.0	40.3
6.00	16.1662	40.8	40.3
7.00	16.1662	40.8	40.3

TABLE A-50. CYCLE NO. 1 EXPOSURE TO 120°F/75% RH ABSORB AND 120°F/0% RH DESORB FOR SPECIMEN HFD

Condition: <u>120°F/75% RH</u>		Absorb; <u>120°F/0% RH</u>		Desorb	
Tare	<u>9.8939 g</u>	Dry Weight	<u>6.5786 g</u>	Dry Capacitance	<u>#15, #16</u> <u>44.3, 40.7 pf</u>
Specimen No.	<u>HFD</u>	Absorb No.	<u>1</u>	Start Date	<u>2/21/79</u>
Time (Days)		Weight (g)	Capacitance (pf)		
			Sensor #15	Sensor #16	
0.00		16.5028	44.3	40.7	
3 min.	@ 120°F with Fan On	16.5121	48.4	43.6	
0.1 Day	@ Dewpoint - Fan On	16.5440	49.0	43.7	
0.1 Day	@ Dewpoint - Fan Off	16.5257	49.0	43.7	
0.25	- Fan On	16.6315	49.2	43.9	
0.25	- Fan Off	16.5505	49.2	43.9	
1.00	- Fan On	16.5893	49.9	44.7	
1.00	- Fan Off	16.5714	50.1	44.9	
1.25		16.5783	50.2	44.9	
2.00		16.5817	50.6	45.1	
2.25		16.5819	50.6	45.2	
5.00		16.5822	50.9	45.4	
6.00		16.5825	51.3	45.7	
7.00	- Fan Off	16.5826	51.5	45.8	

Desorb No. <u>1</u>		Start Date <u>2/28/79</u>	
Time (Days)	Weight (g)	Capacitance (pf)	
		Sensor #15	Sensor #16
0.00	16.5826	51.5	45.8
0.25	16.5150	50.5	45.0
1.00	16.4961	48.8	43.7
1.25	16.4948	48.4	43.3
2.00	16.4902	47.9	42.8
5.00	16.4852	46.9	41.7
6.00	16.4830	46.6	41.4
7.00	16.4826	46.5	41.4

TABLE A-51. CYCLE NO. 2 EXPOSURE TO 120°F/75% RH ABSORB
AND 120°F/0% RH DESORB FOR SPECIMEN HFD

Condition: <u>120°F/75% RH</u> Absorb; <u>120°F/0% RH</u> Desorb			
Tare <u>9.8939</u> g	Dry Weight <u>6.5786</u> g	Dry Capacitance <u>44.3, 40.7</u> pf	
Specimen No. <u>HFD</u>	Absorb No. <u>2</u>	Start Date <u>3/7/79</u>	
<u>Time (Days)</u>	<u>Weight (g)</u>	<u>Capacitance (pf)</u>	
		<u>Sensor #15</u>	<u>Sensor #16</u>
0.00	16.4826	46.5	41.4
0.25	16.5189	47.9	42.4
1.00	16.5373	48.8	43.3
1.25	16.5409	49.2	43.7
2.00	16.5419	50.1	44.6
2.25	16.5419	50.1	44.7
5.00	16.5449	50.8	45.5
7.00	16.5451	51.2	45.9

Desorb No. <u>2</u>		Start Date <u>3/14/79</u>	
<u>Time (Days)</u>	<u>Weight (g)</u>	<u>Capacitance (pf)</u>	
		<u>Sensor #15</u>	<u>Sensor #16</u>
0.00	16.5451	51.2	45.9
0.25	16.5072	50.4	45.2
1.00	16.4883	49.7	44.5
1.25	16.4857	48.9	44.0
2.00	16.4765	48.1	43.2
5.00	16.4727	46.6	41.9
6.00	16.4725	46.5	41.9
7.00	16.4725	46.6	41.9

TABLE A-52. CYCLE NO. 1 EXPOSURE TO 120°F/75% RH ABSORB
AND 120°F/0% RH DESORB FOR SPECIMEN IFD

Condition: <u>120°F/75% RH</u> Absorb; <u>120°F/0% RH</u> Desorb			
Tare <u>9.9087</u> g	Dry Weight <u>6.5966</u> g	Dry Capacitance <u>37.4, 37.8</u> pf	
Specimen No. <u>IFD</u>	Absorb No. <u>1</u>	Start Date <u>2/21/79</u>	
<u>Time (Days)</u>	<u>Weight (g)</u>	<u>Capacitance (pf)</u>	
		<u>Sensor #17</u>	<u>Sensor #18</u>
0.00	16.5177	37.4	38.1
3 min. @ 120°F with Fan On	16.5263	38.6	39.9
0.1 Day at Dewpoint - Fan On	16.5531	39.1	40.3
0.1 Day at Dewpoint - Fan Off	16.5377	40.2	40.4
0.25 - Fan On	16.5879	40.7	40.8
0.25 - Fan Off	16.5711	40.9	40.8
1.00 - Fan On	16.5994	41.4	41.0
1.00 - Fan Off	16.5919	41.2	41.1
1.25	16.5990	41.4	41.2
2.00	16.6041	41.6	41.5
2.25	16.6043	41.6	41.5
5.00	16.6048	43.0	42.2
6.00	16.6049	43.6	42.5
7.00 - Fan Off	16.6049	43.8	42.8
Desorb No. <u>1</u>		Start Date <u>2/28/79</u>	
<u>Time (Days)</u>	<u>Weight (g)</u>	<u>Capacitance (pf)</u>	
		<u>Sensor #17</u>	<u>Sensor #18</u>
0.00	16.6049	43.8	42.8
0.25	16.5370	42.5	41.3
1.00	16.5226	40.9	39.7
1.25	16.5214	40.6	39.4
2.00	16.5149	40.0	38.9
5.00	16.5105	39.3	38.2
6.00	16.5088	38.9	37.9
7.00	16.5084	38.8	37.8

TABLE A-53. CYCLE NO. 2 EXPOSURE TO 120°F/75% RH ABSORB
AND 120°F/0% RH DESORB FOR SPECIMEN IFD

Condition: <u>120°F/75% RH</u> Absorb; <u>120°F/0% RH</u> Desorb			
Tare <u>9.9087</u> g	Dry Weight <u>6.5966</u> g	Dry Capacitance <u>37.4, 37.8</u> pf	
Specimen No. <u>IFD</u>	Absorb No. <u>2</u>	Start Date <u>3/7/79</u>	
<u>Time (Days)</u>	<u>Weight (g)</u>	<u>Capacitance (pf)</u>	
		<u>Sensor #17</u>	<u>Sensor #18</u>
0.00	16.5084	38.8	37.8
0.25	16.5475	40.4	39.9
1.00	16.5642	41.1	40.5
1.25	16.5682	41.8	40.9
2.00	16.5690	42.9	41.7
2.25	16.5690	42.9	41.7
5.00	16.5722	43.4	42.3
7.00	16.5726	43.8	42.8

Desorb No. <u>2</u>		Start Date <u>3/14/79</u>	
<u>Time (Days)</u>	<u>Weight (g)</u>	<u>Capacitance (pf)</u>	
		<u>Sensor #17</u>	<u>Sensor #18</u>
0.00	16.5726	43.8	42.8
0.25	16.5391	42.6	41.3
1.00	16.5205	42.1	40.7
1.25	16.5179	41.2	40.2
2.00	16.5090	39.7	38.7
5.00	16.5054	38.7	37.8
6.00	16.5054	38.7	37.8
7.00	16.5053	38.7	37.8

TABLE A-54. CYCLE NO. 1 EXPOSURE TO 160°F/98% RH ABSORB AND 160°F/0% RH DESORB FOR 13-PLY SPECIMEN A

Condition: 160°F/98% RH Absorb; 160°F/0% RH Desorb

Tare 14.4071g Dry Weight 16.9170 g Dry Capacitance * pf

Specimen No. A Absorb No. 1 Start Date 1/4/79

Time (Days)	Weight (g)	Capacitance (pf)					
		S1	S2	S3	S4	S5	S6
0.00	31.3241	39.3	33.8	40.9	34.9	44.1	31.1
0.25	31.4033	44.1	37.5	43.5	36.9	44.2	39.9
1.00	31.4759	46.2	42.3	45.7	42.8	45.0	40.4
4.00	31.5231	50.7	43.0	48.0	43.9	48.3	43.2
8.00	31.5625	61.7	43.5	50.2	48.3	59.3	47.0
15.00	31.6080	63.5	47.9	54.3	54.0	60.2	51.7
20.25	31.6590	69.3	48.5	55.9	54.4	61.9	60.2
25.00	31.6827	84.1	66.3	75.3	56.8	64.8	64.7
32.00	31.6883	87.9	66.8	77.8	61.1	65.1	66.4
36.00	31.6941	89.3	68.3	80.1	67.4	67.0	67.7
40.00	31.6982	93.6	71.4	81.5	67.9	72.2	74.6
42.00	31.7001	94.1	71.7	81.7	68.2	72.6	75.0

*Capacitance readings are shown for six sensors numbered S1 through S6.

Desorb No. 1 Start Date 2/15/79

Time (Days)	Weight (g)	Capacitance (pf)					
		S1	S2	S3	S4	S5	S6
0.00	31.7001	94.1	71.7	81.7	68.2	72.6	75.0
0.21	31.5948	75.9	60.1	59.2	43.6	53.0	49.8
1.00	31.5505	51.3	48.3	53.7	41.1	42.8	40.9
5.00	31.4815	45.6	40.4	Short	39.5	Short	35.1
8.00	31.4573	43.2	38.8	-	38.9	-	34.7
13.25 ⁽¹⁾	31.4266	42.1	37.2	-	37.1	-	33.2
20.25 ⁽²⁾	31.4131	41.5	36.7	-	36.9	-	32.6
25.00 ⁽¹⁾	31.3983	Short	36.1	-	36.3	-	31.9
29.00 ⁽²⁾	31.3956	-	Short	-	35.9	-	31.5
36.00	31.3937	-	-	-	Broke	-	31.3
46.25	31.3905	-	-	-	-	-	31.3

(1) Change condition to 120°F/0% RH

(2) Return condition to 160°F/0% RH

TABLE A-55. CYCLE NO. 1 EXPOSURE TO 160°F/98% RH ABSORB
AND 160°F/0% RH DESORB FOR 13-PLY SPECIMEN B

Condition: <u>160°F/98% RH</u>		Absorb; <u>160°F/0% RH</u>		Desorb			
Tare	<u>12.8570 g</u>	Dry Weight	<u>17.4644 g</u>	Dry Capacitance	<u>* pf</u>		
Specimen No.	<u>B</u>	Absorb No.	<u>1</u>	Start Date	<u>1/4/79</u>		
Time (Days)	Weight (g)	Capacitance (pf)					
		S1	S2	S3	S4	S5	S6
0.00	30.3214	33.4	29.7	32.8	31.5	Broke	21.6
0.25	30.3904	37.7	34.1	35.1	35.0		23.8
1.00	30.4505	44.2	38.4	43.0	41.3		29.6
4.00	30.5027	48.1	42.0	47.9	45.5		31.4
8.00	30.5459	52.8	45.1	48.1	45.9		33.8
15.00	30.6113	63.9	47.2	52.2	46.0		34.4
20.25	30.6579	65.8	50.0	53.5	47.6		35.7
25.00	30.6720	76.3	67.0	58.1	49.3		36.3
32.00	30.6784	78.7	68.4	59.2	Broke		37.6
36.00	30.6840	81.5	71.3	60.7			39.4
40.00	30.6911	83.1	72.4	64.6			40.9
42.00	30.6934	83.6	72.5	64.7			41.1

*Capacitance readings are shown for six sensors numbered S1 through S6.

Desorb No.	<u>1</u>	Start Date	<u>2/15/79</u>				
Time (Days)	Weight (g)	Capacitance (pf)					
		S1	S2	S3	S4	S5	S6
0.00	30.6934	83.6	72.5	64.7	-	-	41.1
0.21	30.5944	70.1	57.3	50.3	-	-	37.5
1.00	30.5342	47.8	42.9	45.3	-	-	33.8
5.00	30.4273	38.9	36.7	43.8	-	-	31.4
8.00	30.4005	37.4	35.2	43.1	-	-	27.6
13.25 ⁽¹⁾	30.3675	36.6	34.3	40.5	-	-	25.4
20.25 ⁽²⁾	30.3542	35.3	33.1	39.7	-	-	24.1
25.00 ⁽¹⁾	30.3394	34.7	32.8	39.0	-	-	23.7
29.00 ⁽²⁾	30.3373	34.3	Short	38.8	-	-	23.4
36.00	30.3353	34.1	-	Broke	-	-	23.0
42.25	30.3321	33.9	-	-	-	-	22.6

(1) Change condition to 120°F/0% RH

(2) Return condition to 160°F/0% RH

TABLE A-56. CYCLE NO. 1 EXPOSURE TO 160°F/98% RH ABSORB AND 160°F/0% RH DESORB FOR 13-PLY SPECIMEN C

Condition: 160°F/98% RH Absorb; 160°F/0% RH Desorb

Tare 15.0688 g Dry Weight 17.1529 g Dry Capacitance * pf

Specimen No. C Absorb No. 1 Start Date 1/4/79

Time (Days)	Weight (g)	Capacitance (pf)					
		S1	S2	S3	S4	S5	S6
0.00	32.2217	33.9	32.0	22.2	32.1	32.2	18.1
0.25	32.3035	39.0	35.5	28.4	54.1	34.5	20.2
1.00	32.3653	43.6	38.4	33.9	55.2	36.9	22.1
4.00	32.4152	79.9	45.2	45.0	66.6	43.1	28.8
8.00	32.4563	85.5	47.1	51.4	68.3	45.1	31.9
15.00	32.5226	Off	50.2	87.4	79.9	49.8	32.6
20.25	32.5765	Scale	81.9	97.4	81.0	51.2	34.6
25.00	32.5963		88.8	Off	82.3	65.8	36.1
32.00	32.6024		96.7	Scale	83.6	73.1	106.4**
36.00	32.6073		97.7		85.1	78.5	70.2
40.00	32.6118		99.8		85.9	78.8	71.0
42.00	32.6139		101.1		86.3	82.8	71.4

*Capacitance readings are shown for six sensors numbered S1 through S6.

**Apparently an erroneous high reading.

Desorb No. 1 Start Date 2/15/79

Time (Days)	Weight (g)	Capacitance (pf)					
		S1	S2	S3	S4	S5	S6
0.00	32.6139	Off	101.1	Off	86.3	82.8	71.4
0.21	32.4911	Scale	85.1	Scale	69.4	65.8	52.6
1.00	32.4209	53.0	48.3	59.6	47.9	42.2	36.9
5.00	32.3088	42.3	37.1	41.5	34.7	38.1	29.7
8.00	32.2842	35.6	34.9	40.9	34.4	37.5	24.0
13.25 ⁽¹⁾	32.2621	35.2	34.4	39.5	34.1	36.8	22.1
20.25 ⁽²⁾	32.2561	33.8	33.3	Short	32.4	33.5	19.2
25.00 ⁽¹⁾	32.2516	33.3	32.9	-	31.8	32.7	18.8
29.00 ⁽²⁾	32.2483	32.6	32.5	-	31.8	32.5	18.3
36.00	32.2246	32.3	Broke	-	29.9	32.3	18.1
42.25	32.2219	32.2	-	-	29.6	32.3	18.1

(1) Change condition to 120°F/0% RH

(2) Return condition to 160°F/0% RH

TABLE A-57. CYCLE NO. 1 EXPOSURE TO 160°F/98% RH ABSORB
AND 160°F/0% RH DESORB FOR 13-PLY SPECIMEN D

Condition: <u>160°F/98% RH</u>		Absorb; <u>160°F/0% RH</u>		Desorb			
Tare	<u>15.2813</u> g	Dry Weight	<u>17.2422</u> g	Dry Capacitance	<u>*</u> pf		
Specimen No.	<u>D</u>	Absorb No.	<u>1</u>	Start Date	<u>1/4/79</u>		
Time (Days)	Weight (g)	Capacitance (pf)					
		S1	S2	S3	S4	S5	S6
0.00	32.5235	37.5	65.8	62.6	67.2	26.7	33.6
0.25	32.5880	44.1	57.2	54.8	89.1	30.6	36.2
1.00	32.6501	48.5	78.0	60.1	91.6	31.1	45.3
4.00	32.7042	64.3	82.6	73.2	117.4	44.2	55.2
8.00	32.7442	Off	83.4	74.6	119.6	46.0	58.3
15.00	32.8295	Scale	123.4	79.7	119.9	51.9	63.7
20.25	32.8856		148.1	81.6	148.6	52.3	69.4
25.00	32.9017		149.7	83.4	149.6	58.2	76.5
32.00	33.0690		206.1	91.4	210.0	60.1	79.3
36.00	33.0726		214.3	113.1	217.7	67.4	83.6
40.00	33.0758		224.1	128.2	228.6	73.8	88.3
42.00	33.0776		226.4	Broke	229.0	82.3	89.6

*Capacitance readings are shown for six sensors numbered S1 through S6.

Desorb No. <u>1</u>		Start Date <u>2/15/79</u>					
Time (Days)	Weight (g)	Capacitance (pf)					
		S1	S2	S3	S4	S5	S6
0.00	33.0776	Broke	226.4	-	229	82.3	89.6
0.21	32.8877	-	134.4	-	127.5	63.4	66.1
1.00	32.8021	-	82.8	-	110.3	56.4	48.6
5.00	32.7027	-	80.2	-	90.6	49.1	42.8
8.00	32.6753	-	78.1	-	89.3	47.4	38.9
13.25 ⁽¹⁾	32.6540	-	77.8	-	88.7	43.7	37.1
20.25 ⁽²⁾	32.6435	-	77.0	-	88.3	Short	36.3
25.00 ⁽¹⁾	32.6358	-	76.9	-	88.3	-	35.7
29.00 ⁽²⁾	32.6318	-	76.9	-	88.1	-	35.2
36.00	32.6037	-	76.9	-	88.0	-	33.4
42.25	32.6006	-	76.7	-	87.4	-	33.2

(1) Change condition to 120°F/0% RH

(2) Return condition to 160°F/0% RH

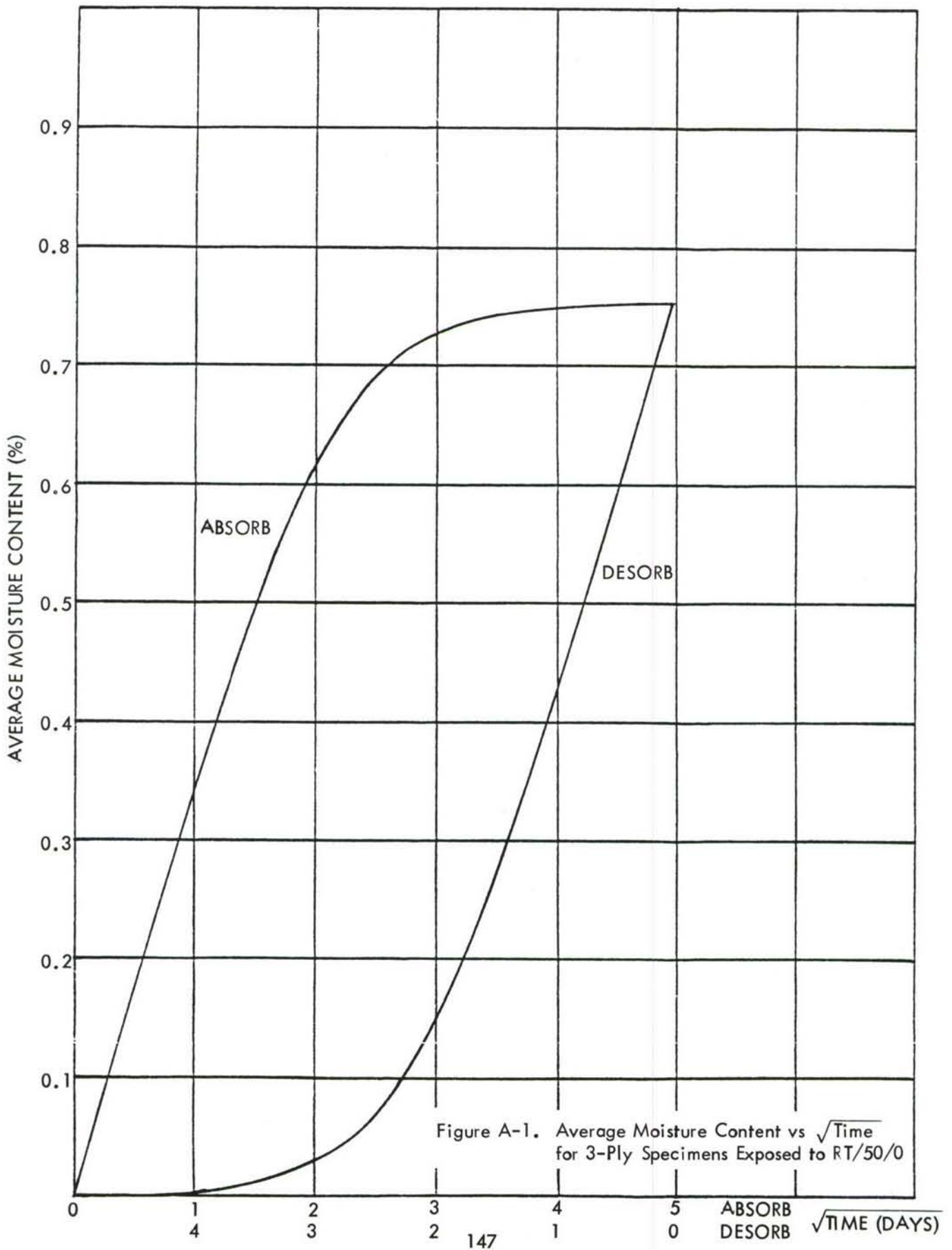
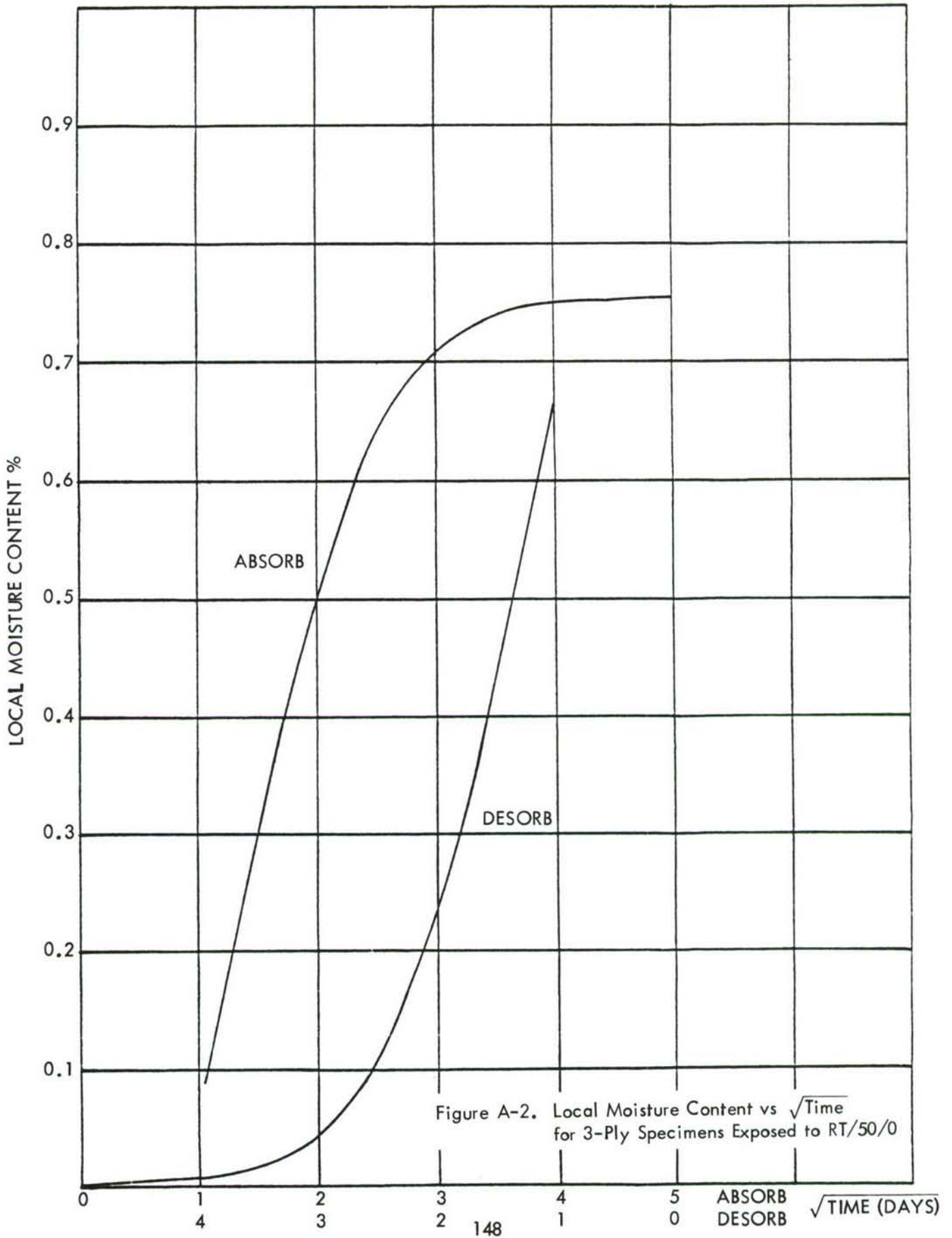

Figure A-1. Average Moisture Content vs $\sqrt{\text{Time}}$ for 3-Ply Specimens Exposed to RT/50/0



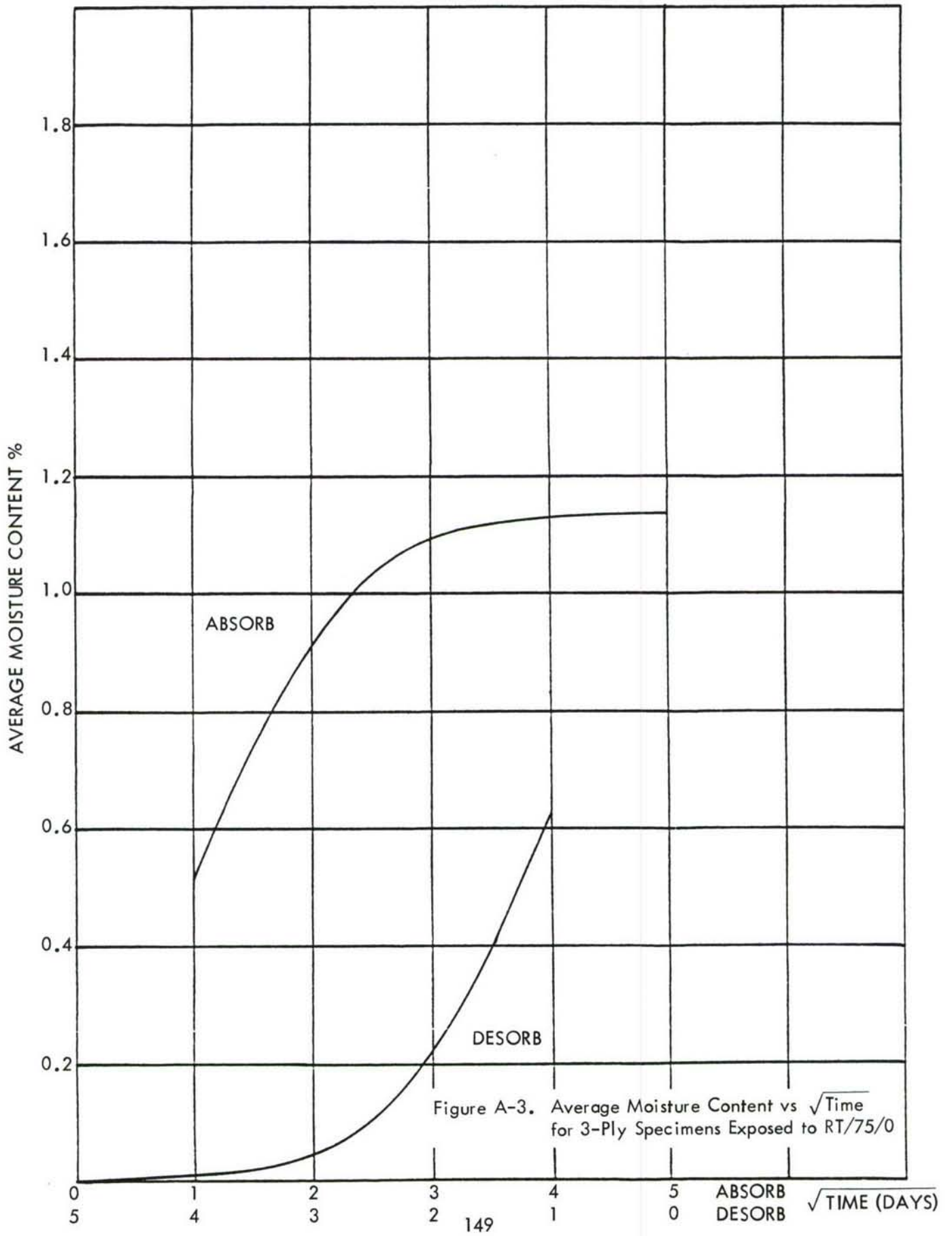
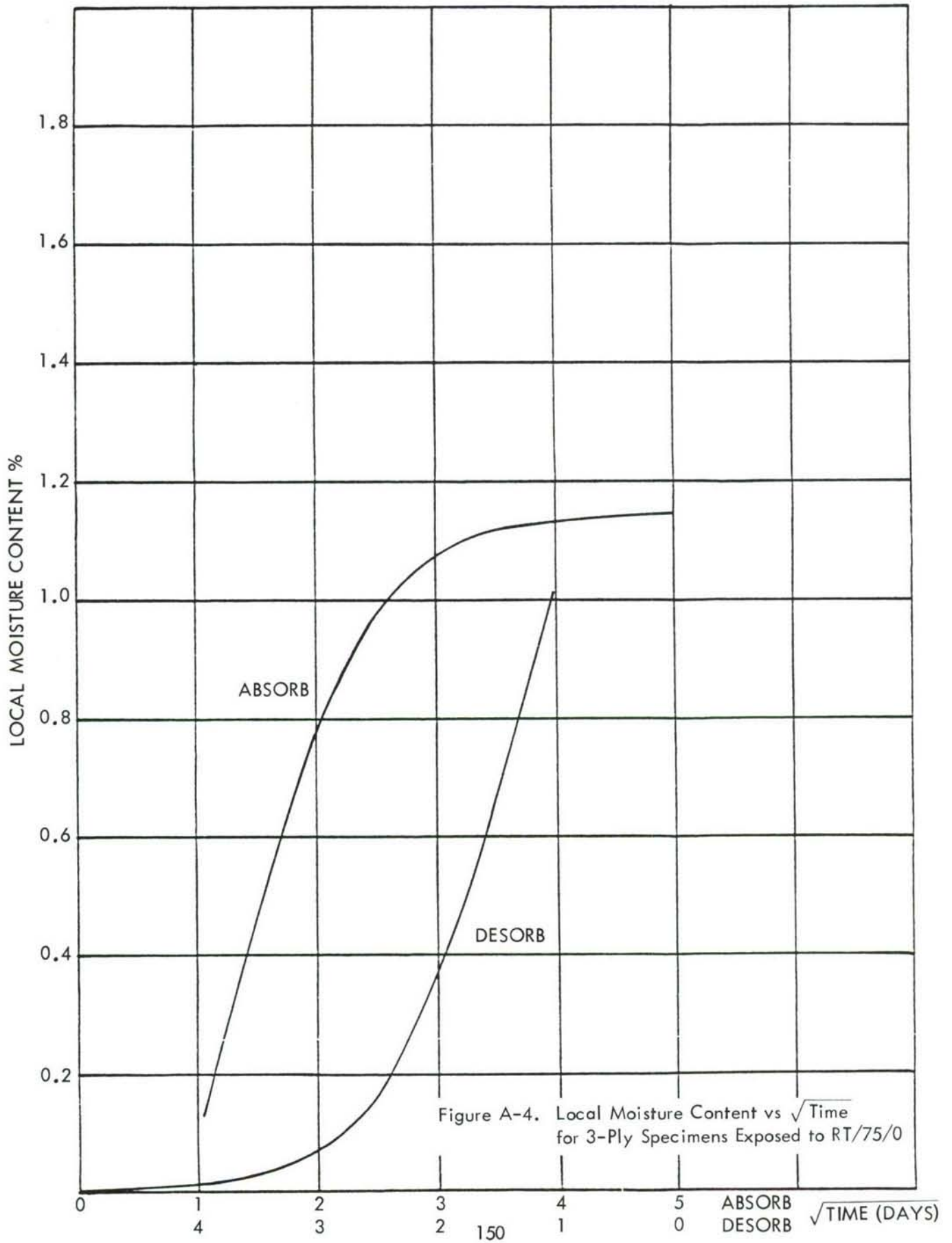

Figure A-3. Average Moisture Content vs $\sqrt{\text{Time}}$ for 3-Ply Specimens Exposed to RT/75/0



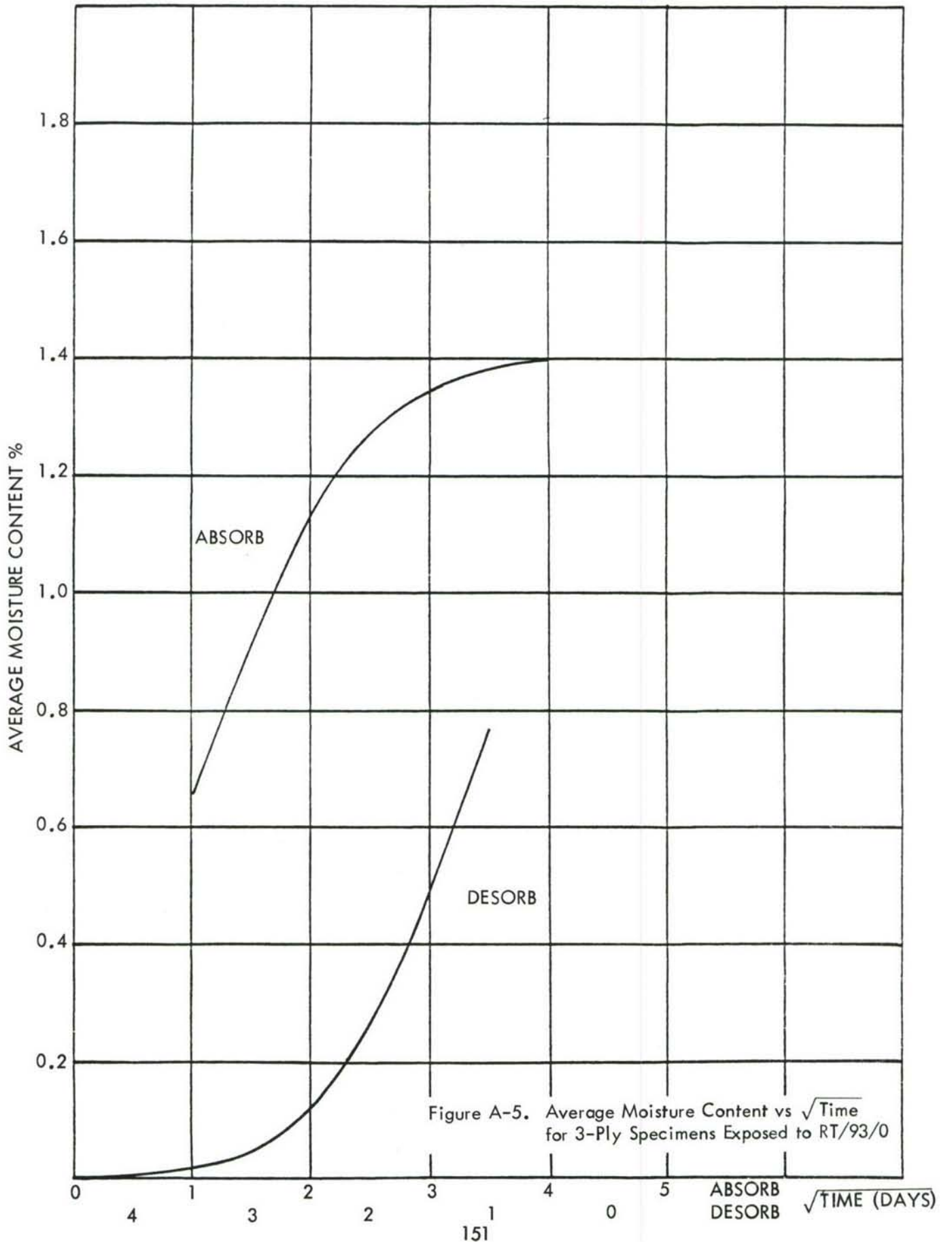

Figure A-5. Average Moisture Content vs $\sqrt{\text{Time}}$ for 3-Ply Specimens Exposed to RT/93/0

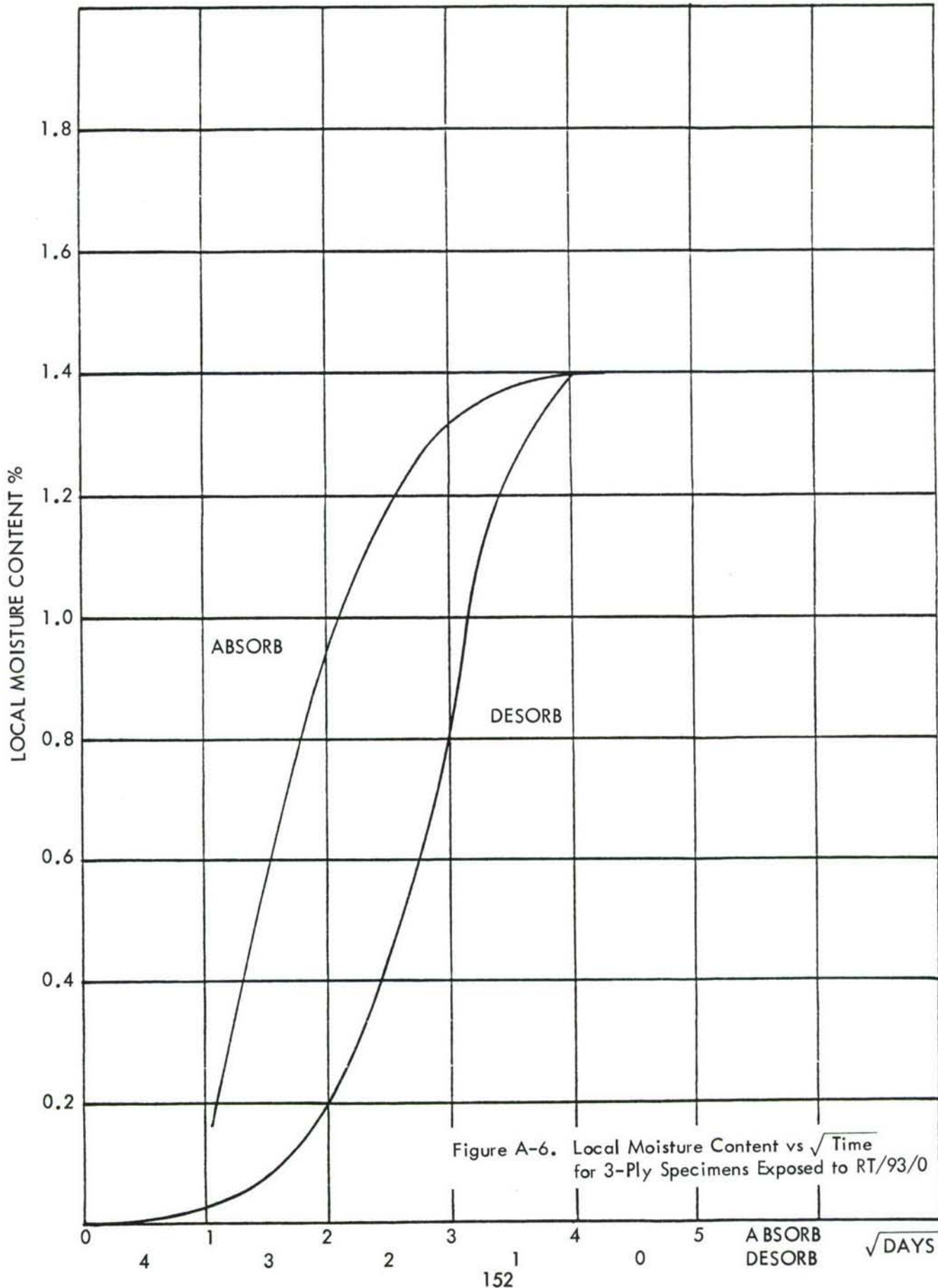

Figure A-6. Local Moisture Content vs $\sqrt{\text{Time}}$ for 3-Ply Specimens Exposed to RT/93/0

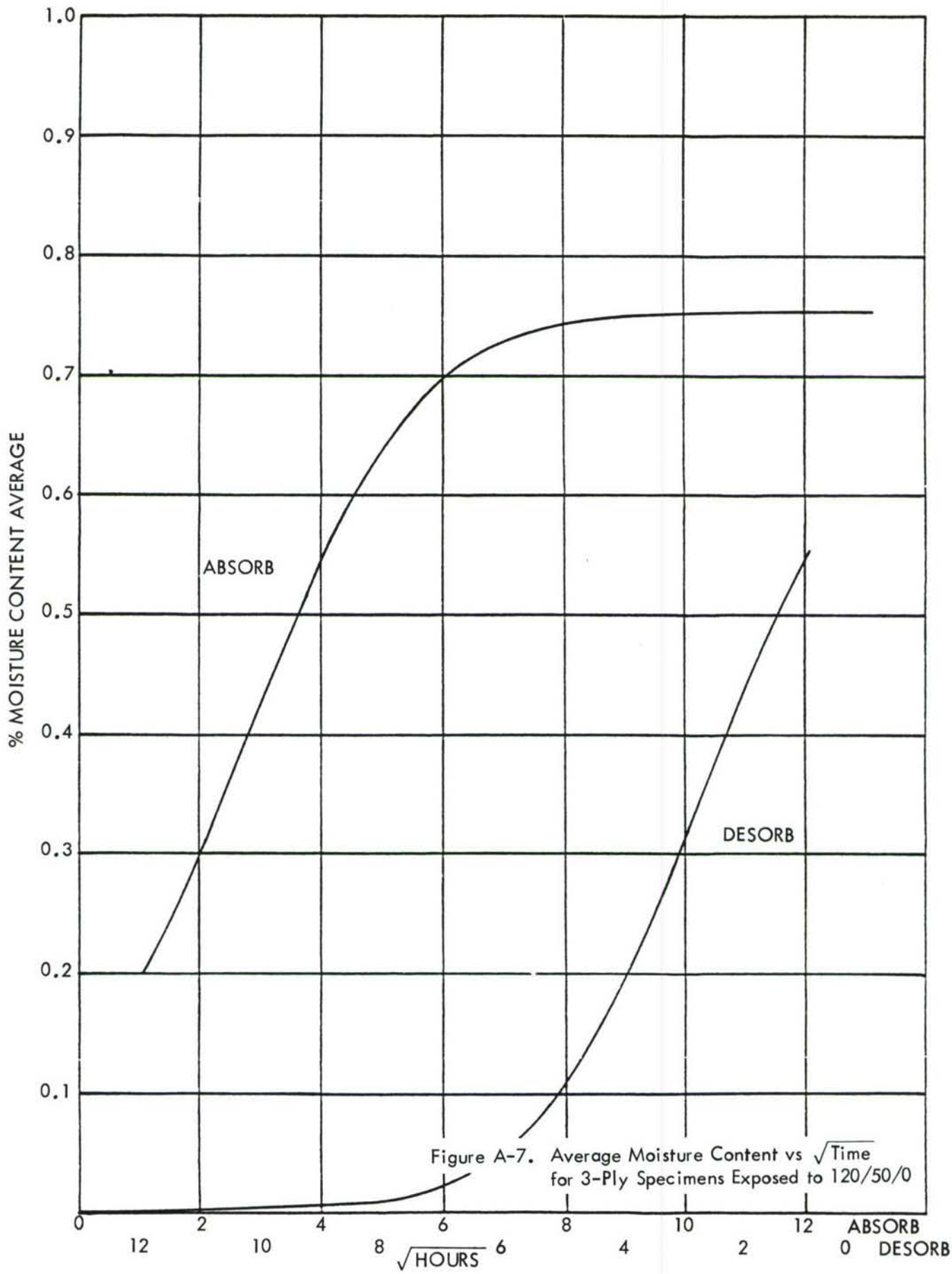

Figure A-7. Average Moisture Content vs $\sqrt{\text{Time}}$ for 3-Ply Specimens Exposed to 120/50/0

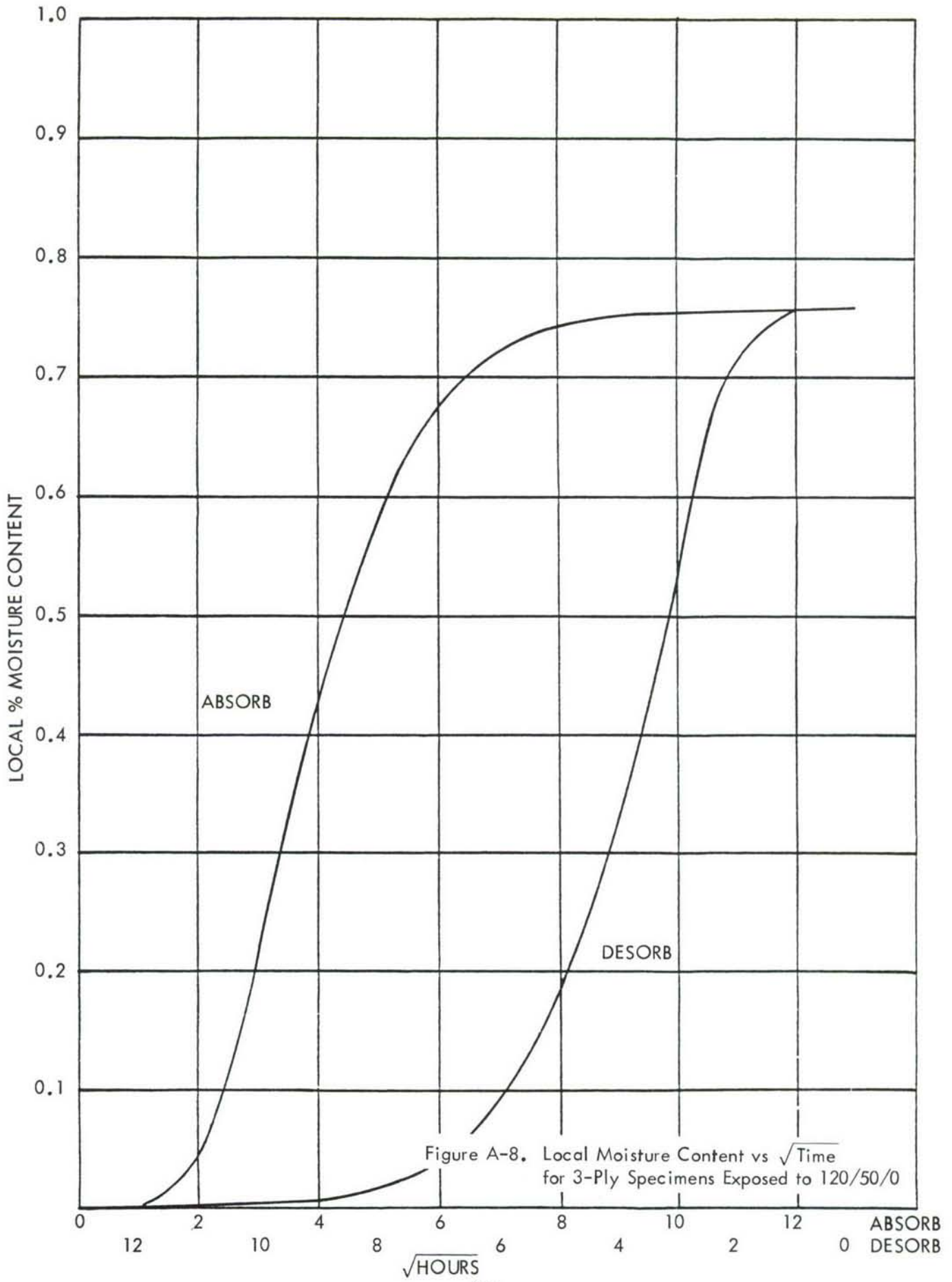

Figure A-8. Local Moisture Content vs $\sqrt{\text{Time}}$ for 3-Ply Specimens Exposed to 120/50/0

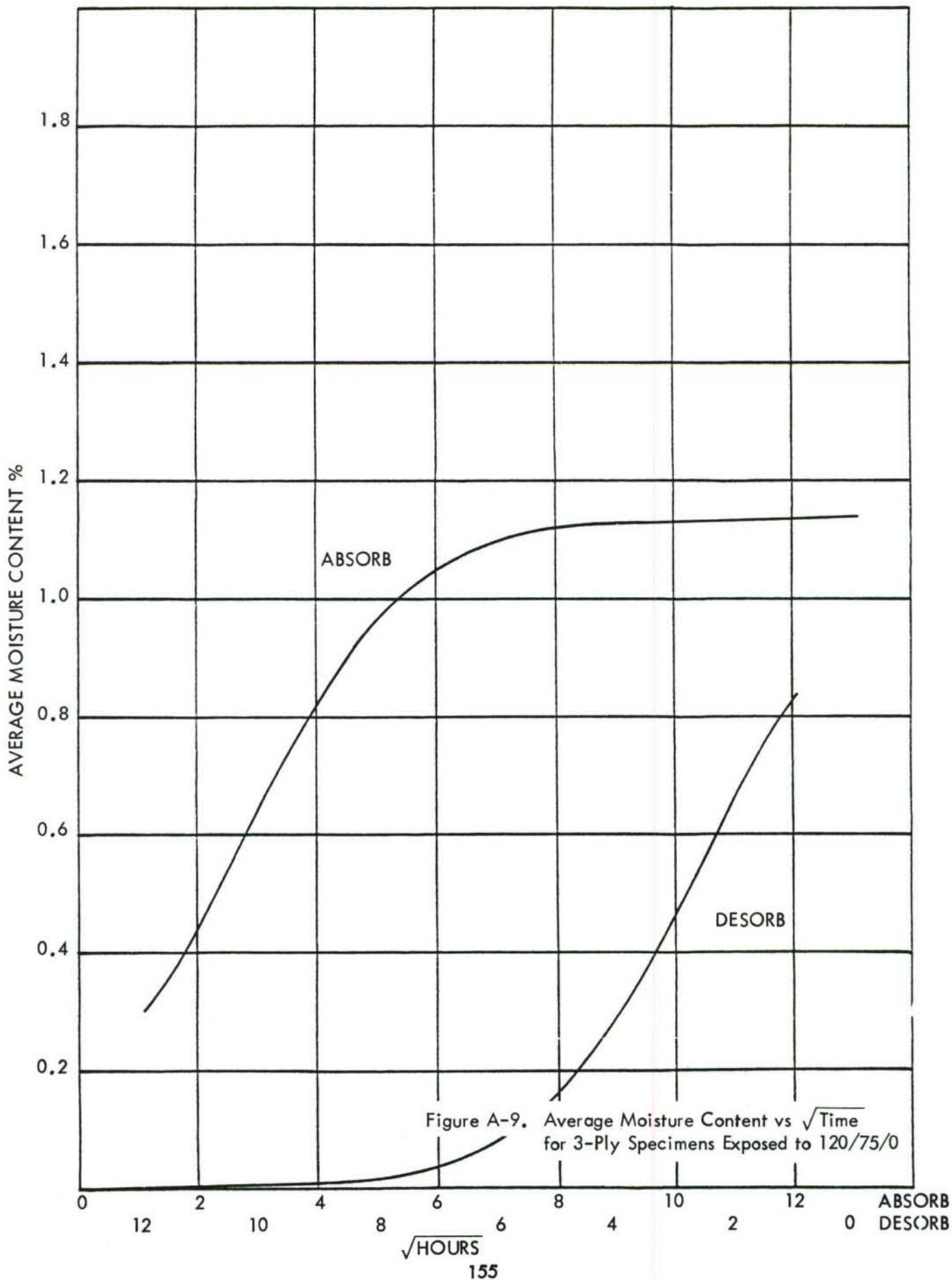

Figure A-9. Average Moisture Content vs $\sqrt{\text{Time}}$ for 3-Ply Specimens Exposed to 120/75/0

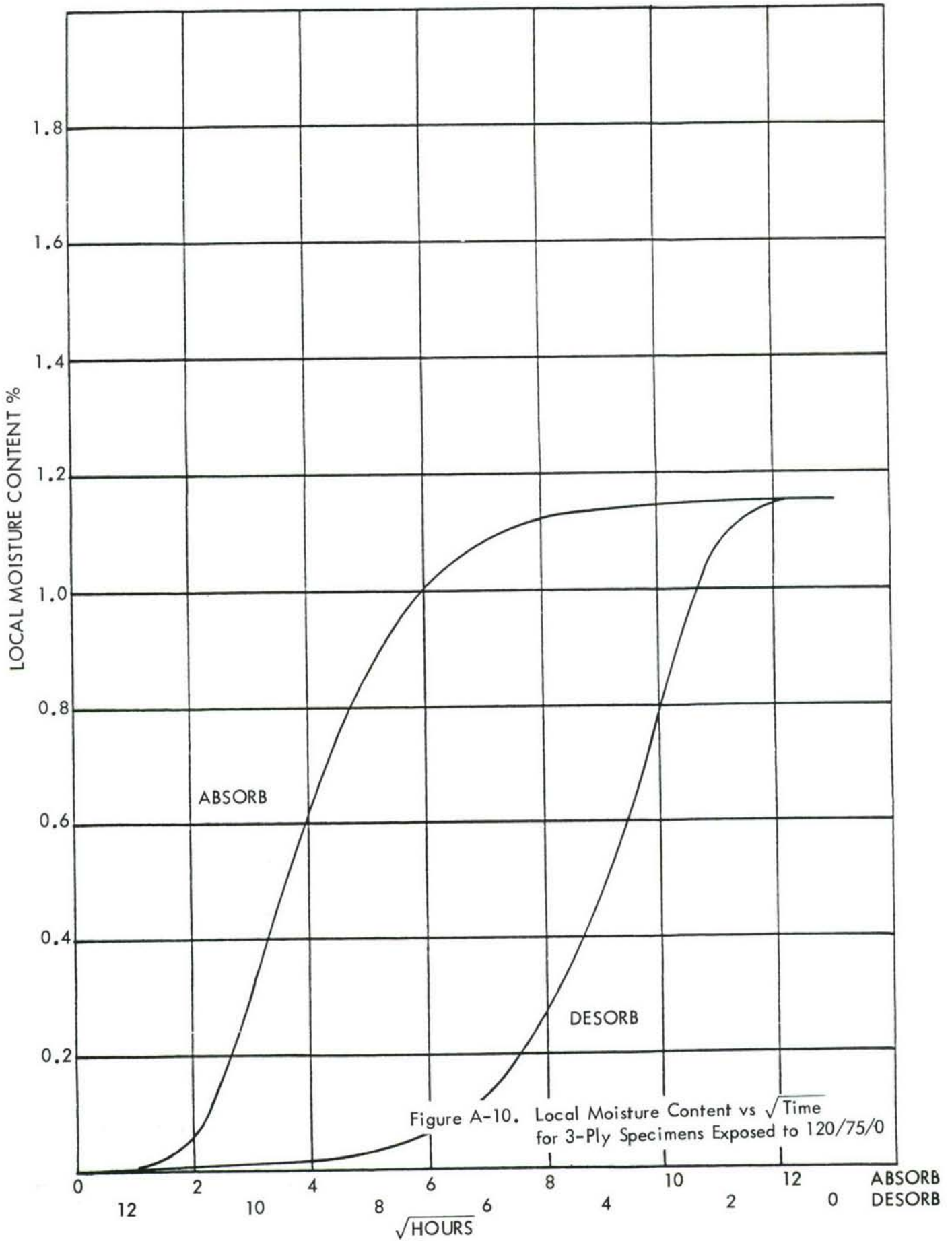

Figure A-10. Local Moisture Content vs $\sqrt{\text{Time}}$ for 3-Ply Specimens Exposed to 120/75/0

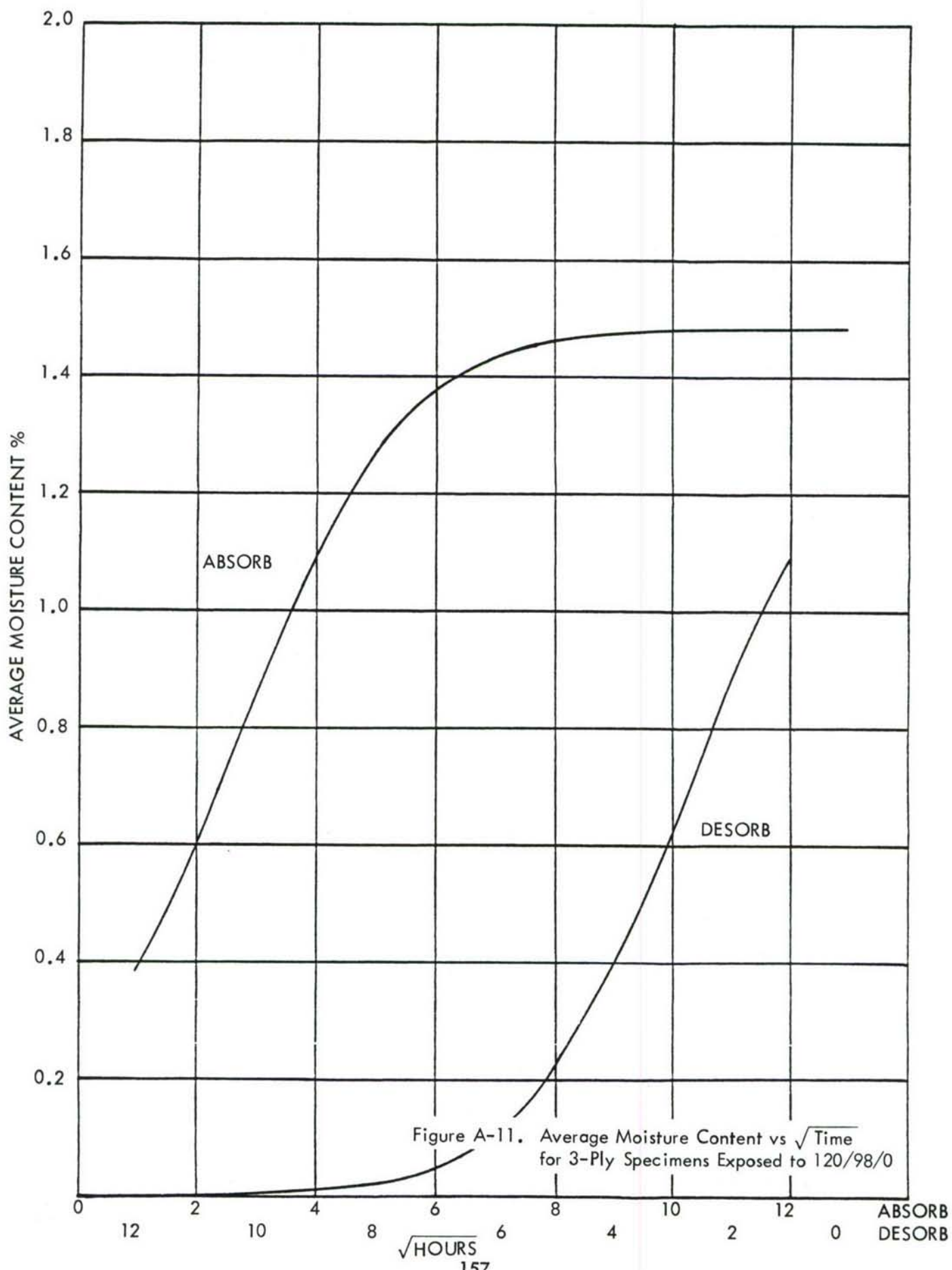

Figure A-11. Average Moisture Content vs $\sqrt{\text{Time}}$ for 3-Ply Specimens Exposed to 120/98/0

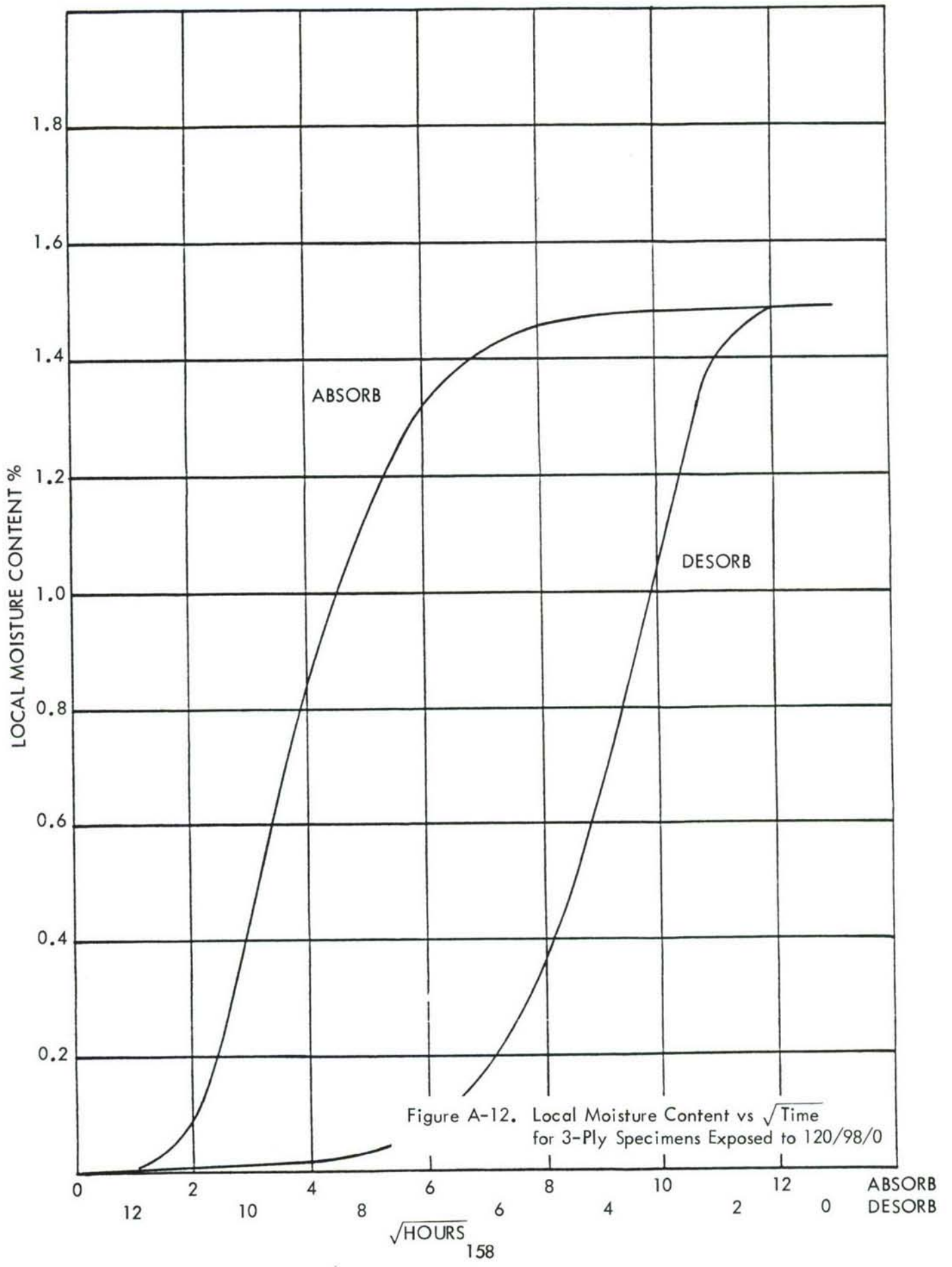

Figure A-12. Local Moisture Content vs $\sqrt{\text{Time}}$ for 3-Ply Specimens Exposed to 120/98/0

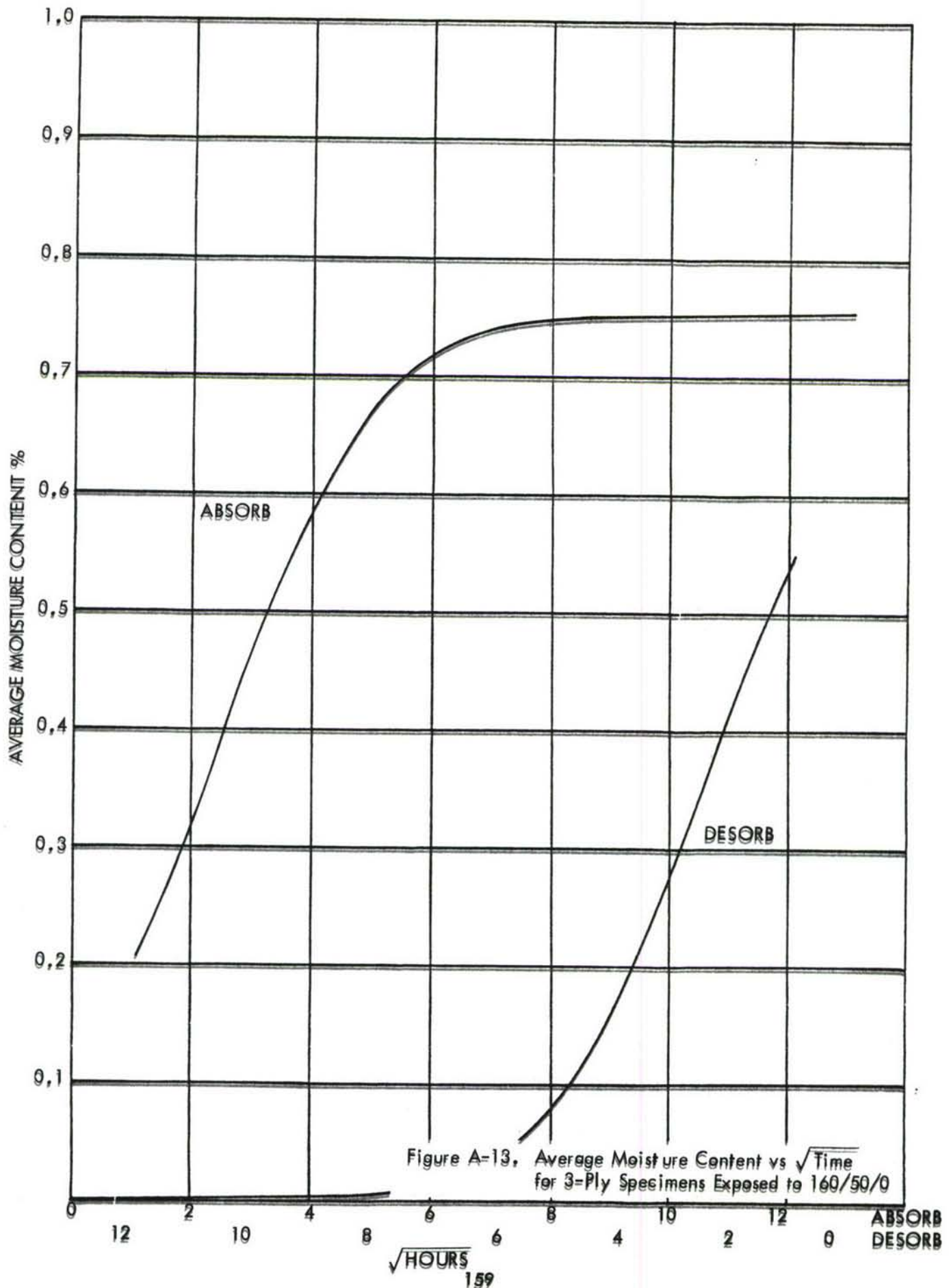
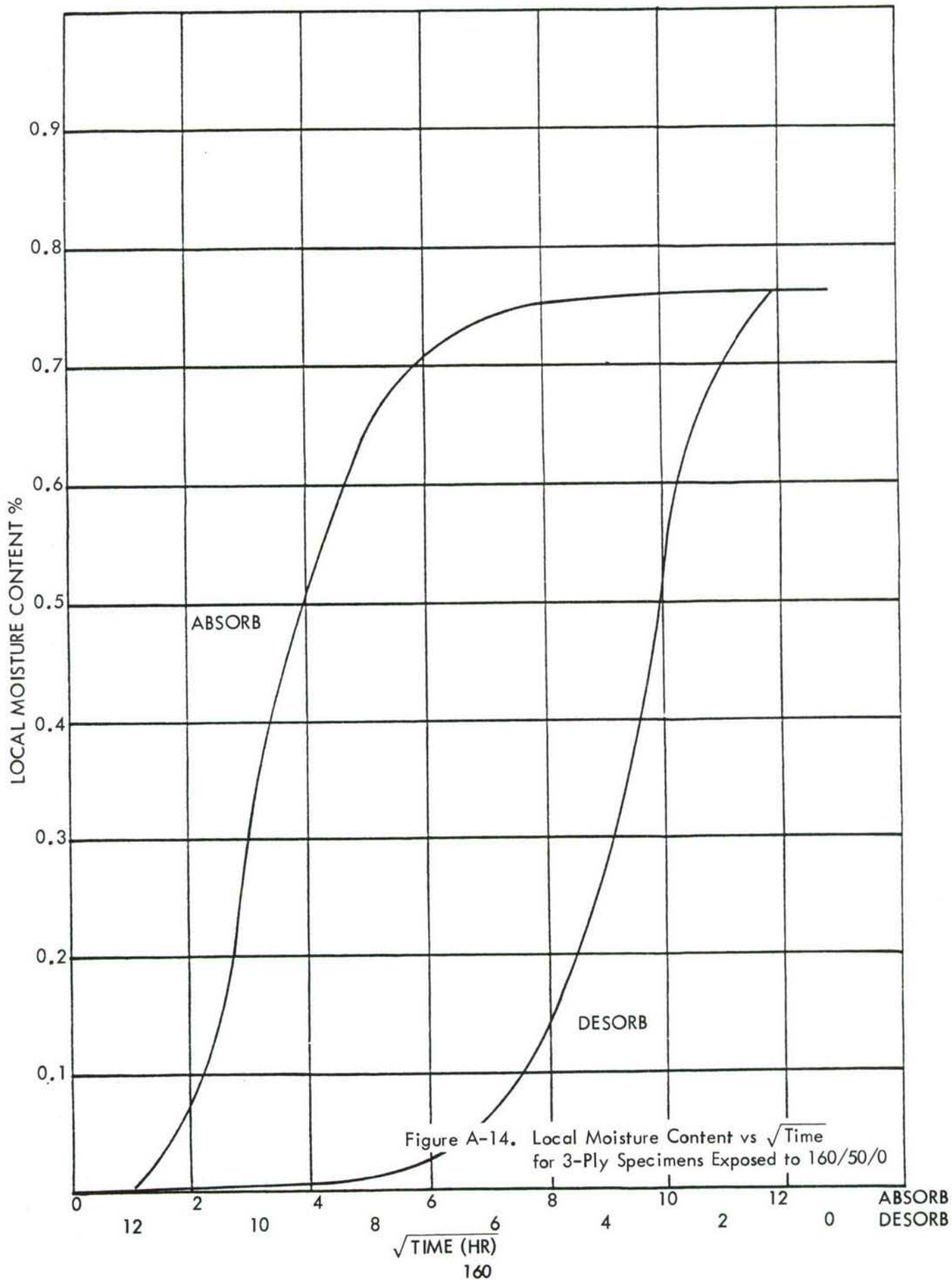

Figure A-13. Average Moisture Content vs $\sqrt{\text{Time}}$ for 3-Ply Specimens Exposed to 160/50/0



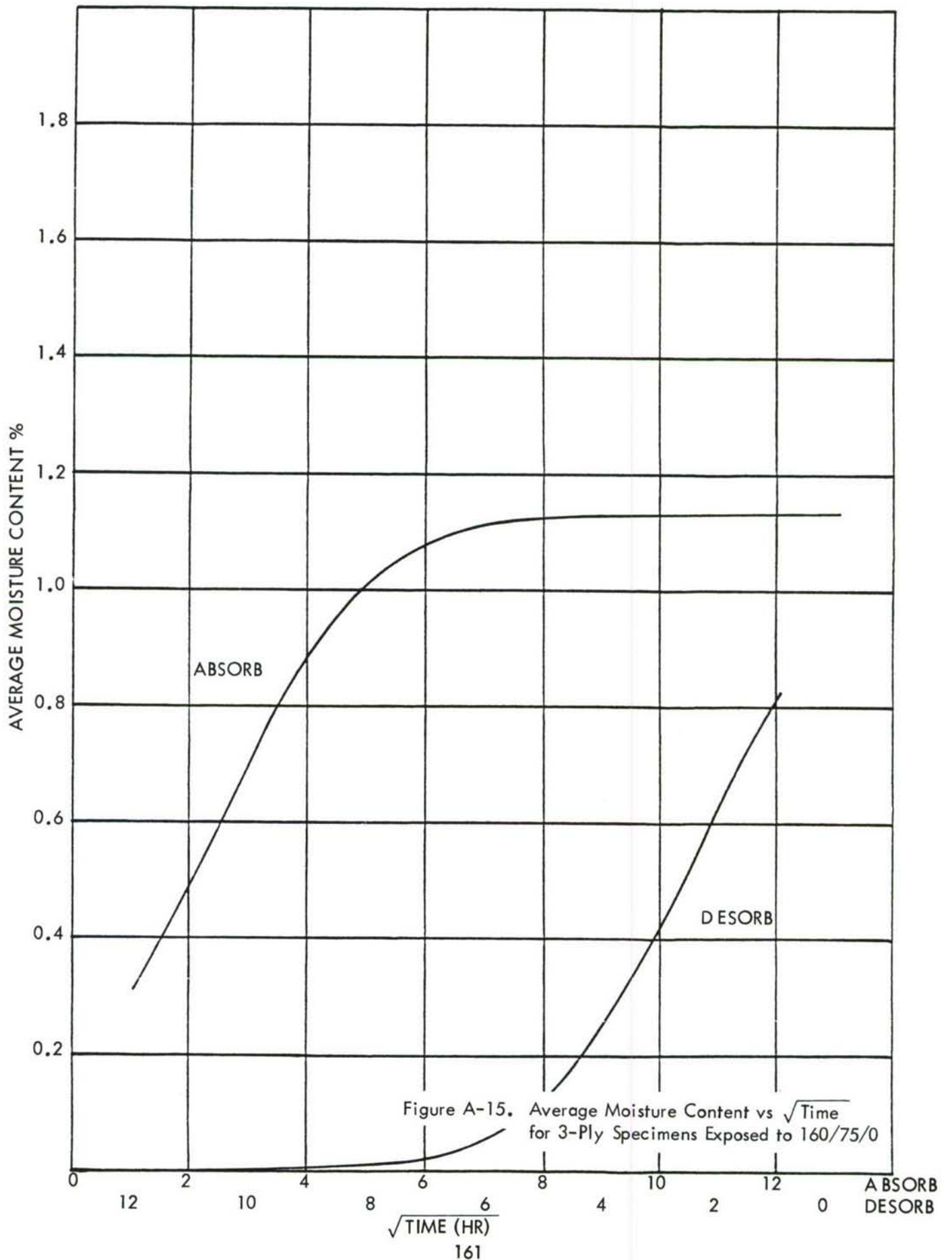
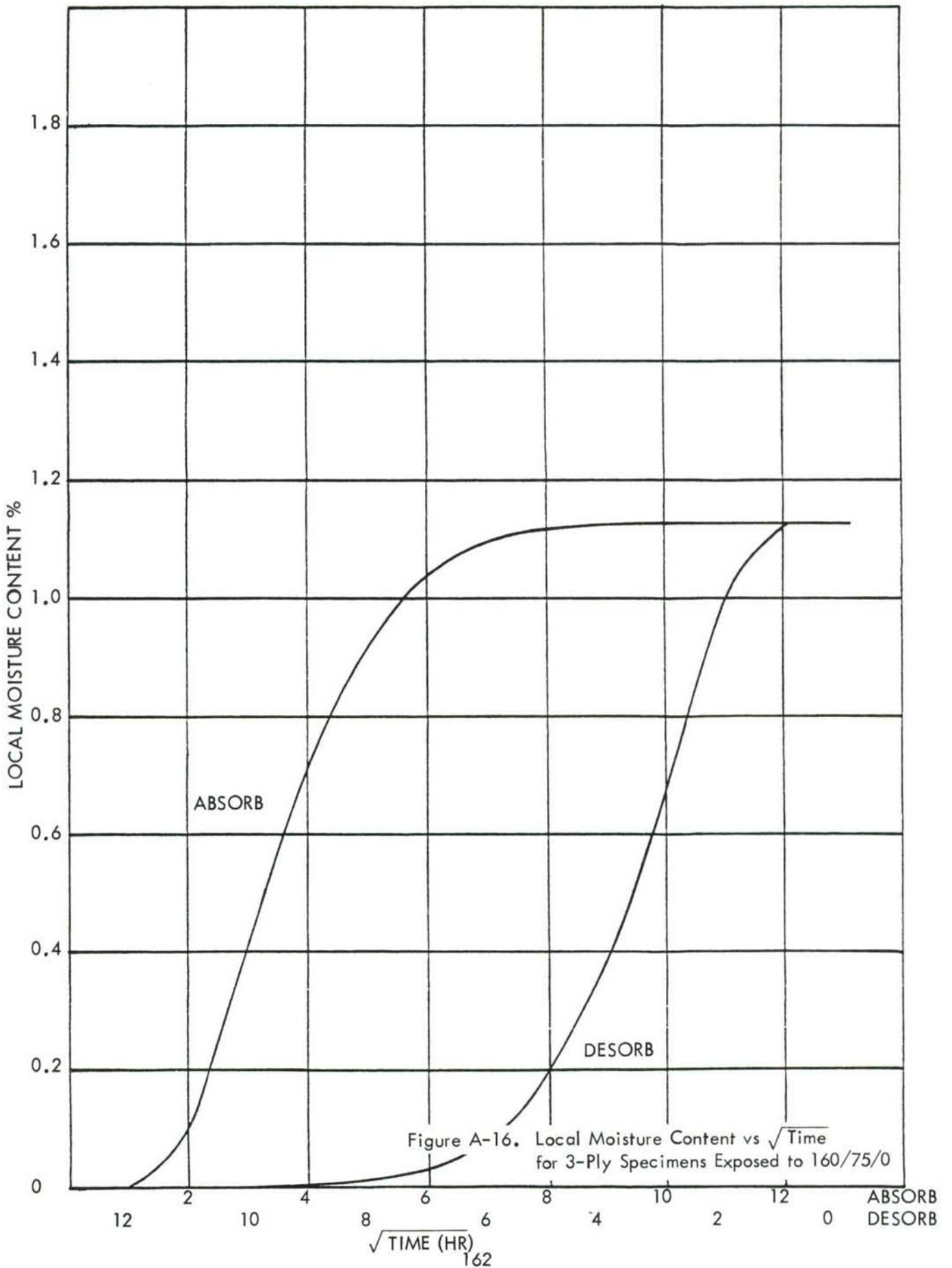

Figure A-15. Average Moisture Content vs $\sqrt{\text{Time}}$ for 3-Ply Specimens Exposed to 160/75/0



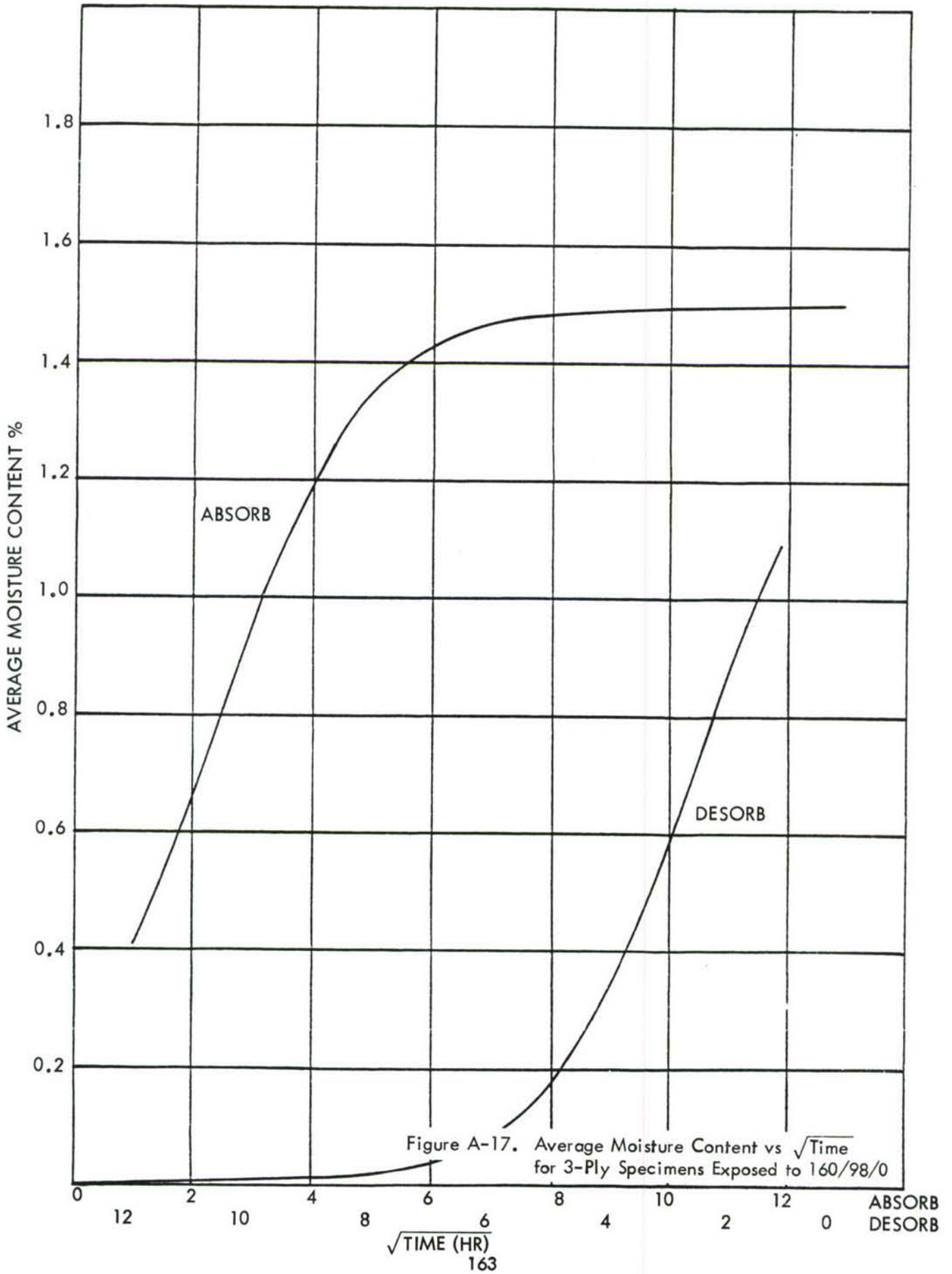

Figure A-17. Average Moisture Content vs $\sqrt{\text{Time}}$ for 3-Ply Specimens Exposed to 160/98/0

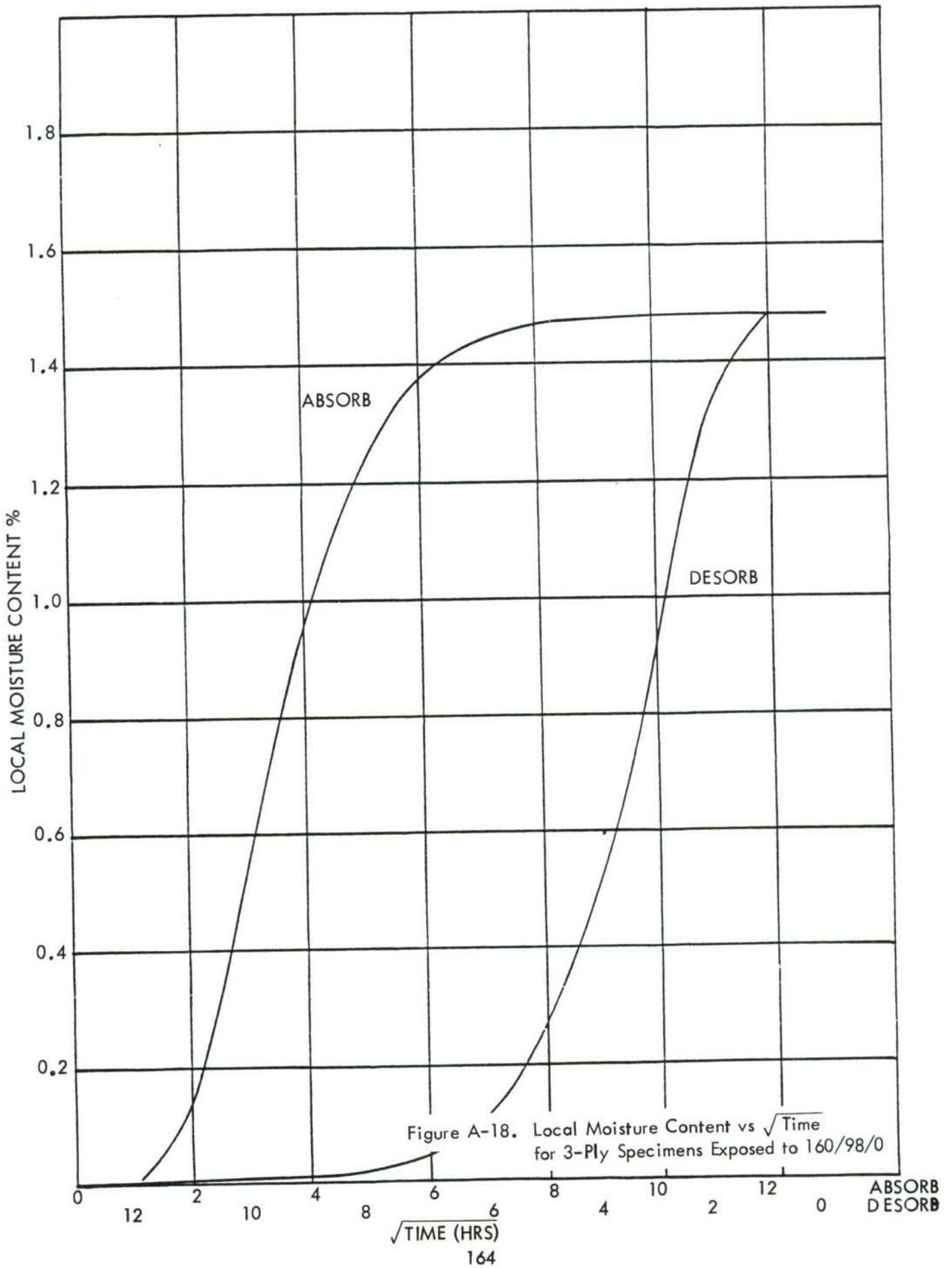
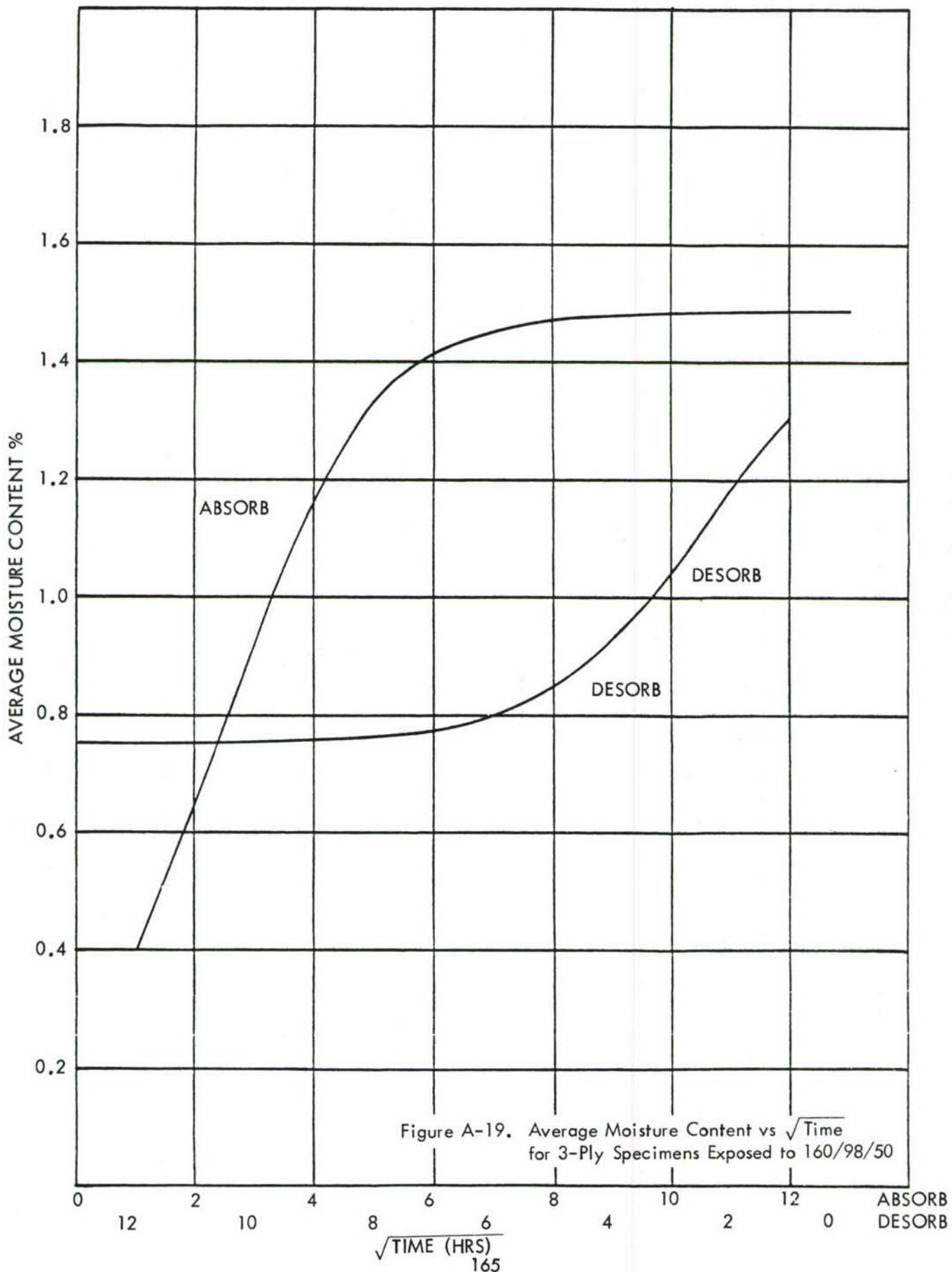
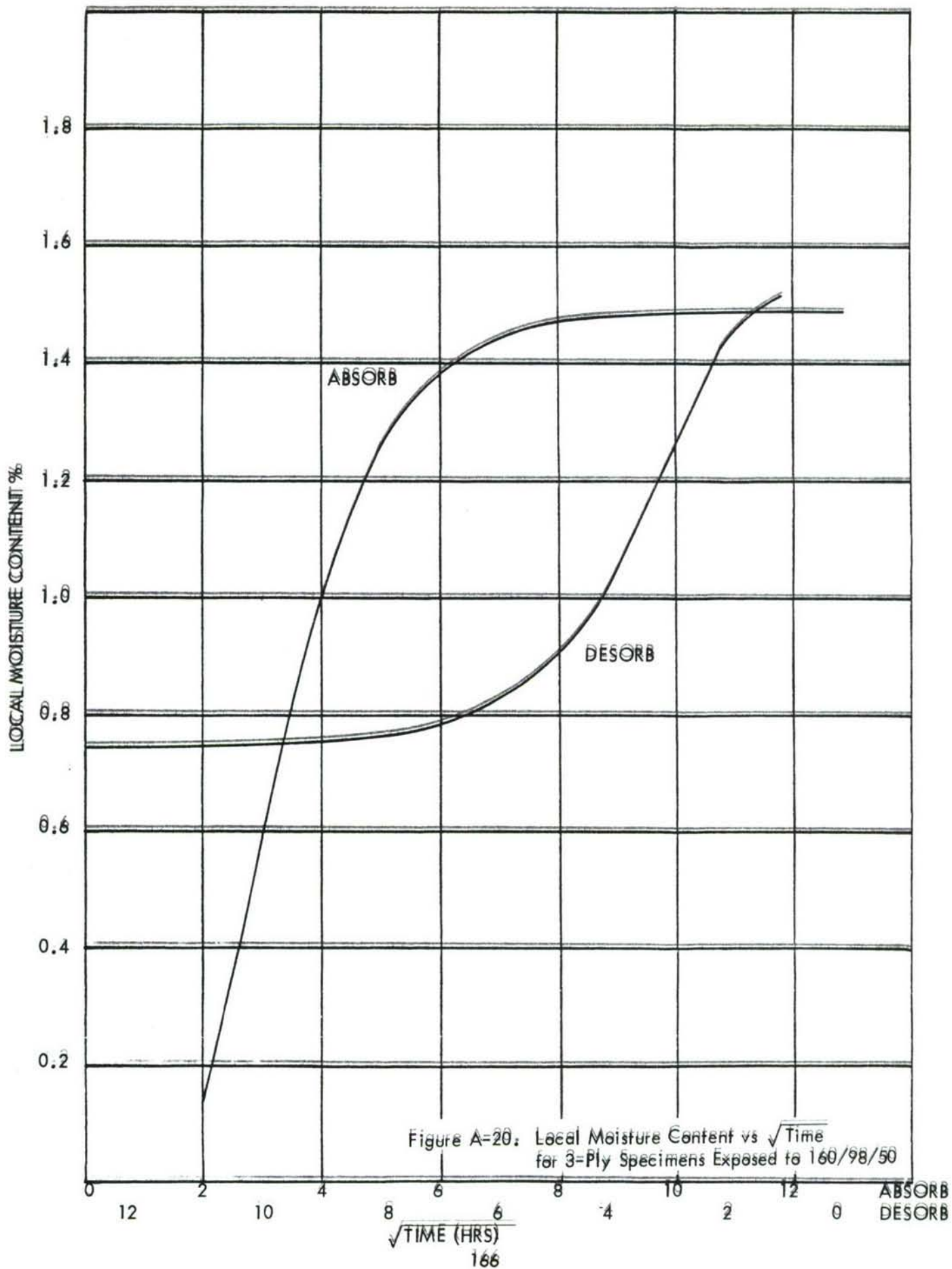

Figure A-18. Local Moisture Content vs $\sqrt{\text{Time}}$ for 3-Ply Specimens Exposed to 160/98/0





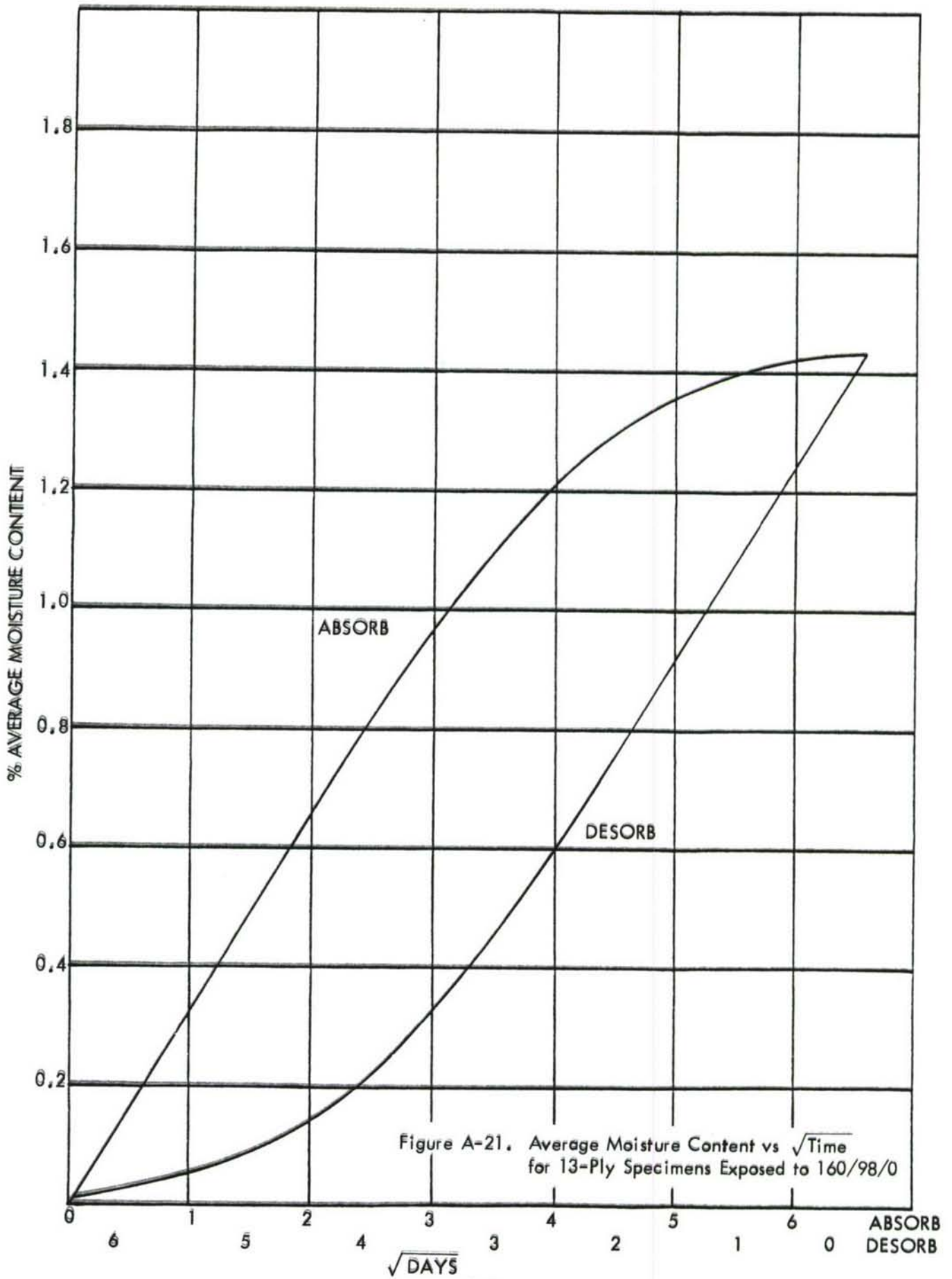
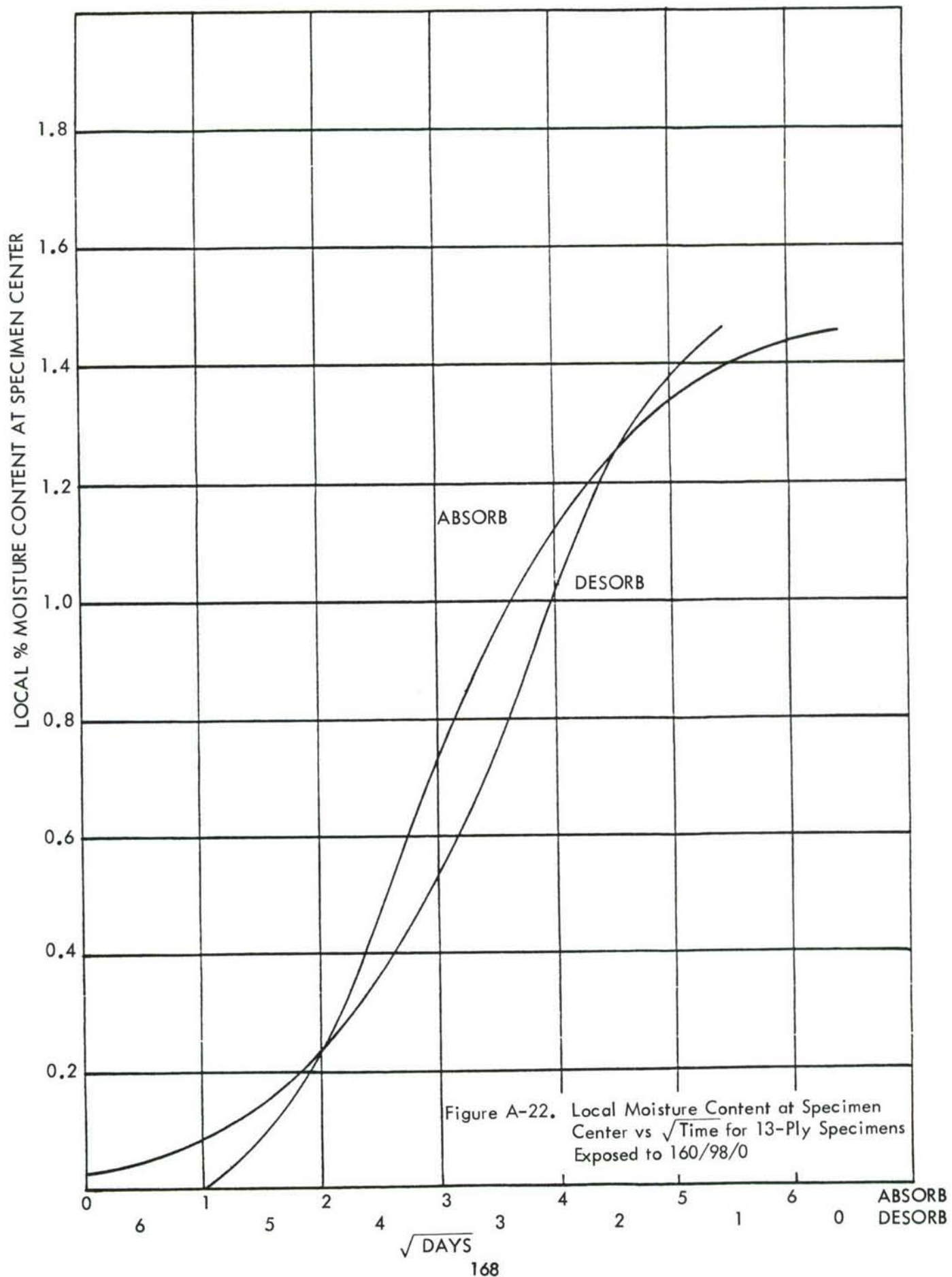

Figure A-21. Average Moisture Content vs $\sqrt{\text{Time}}$ for 13-Ply Specimens Exposed to 160/98/0



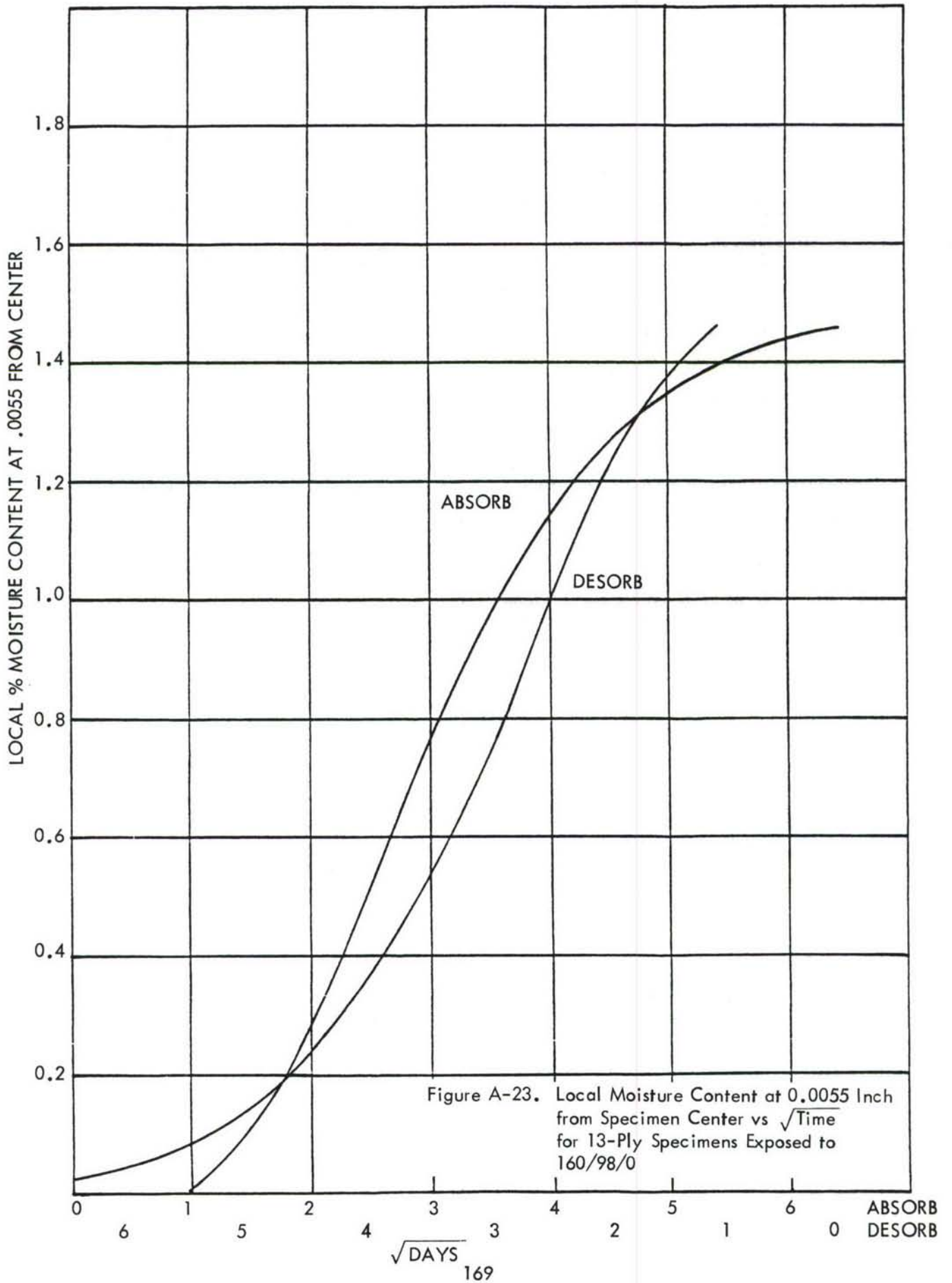
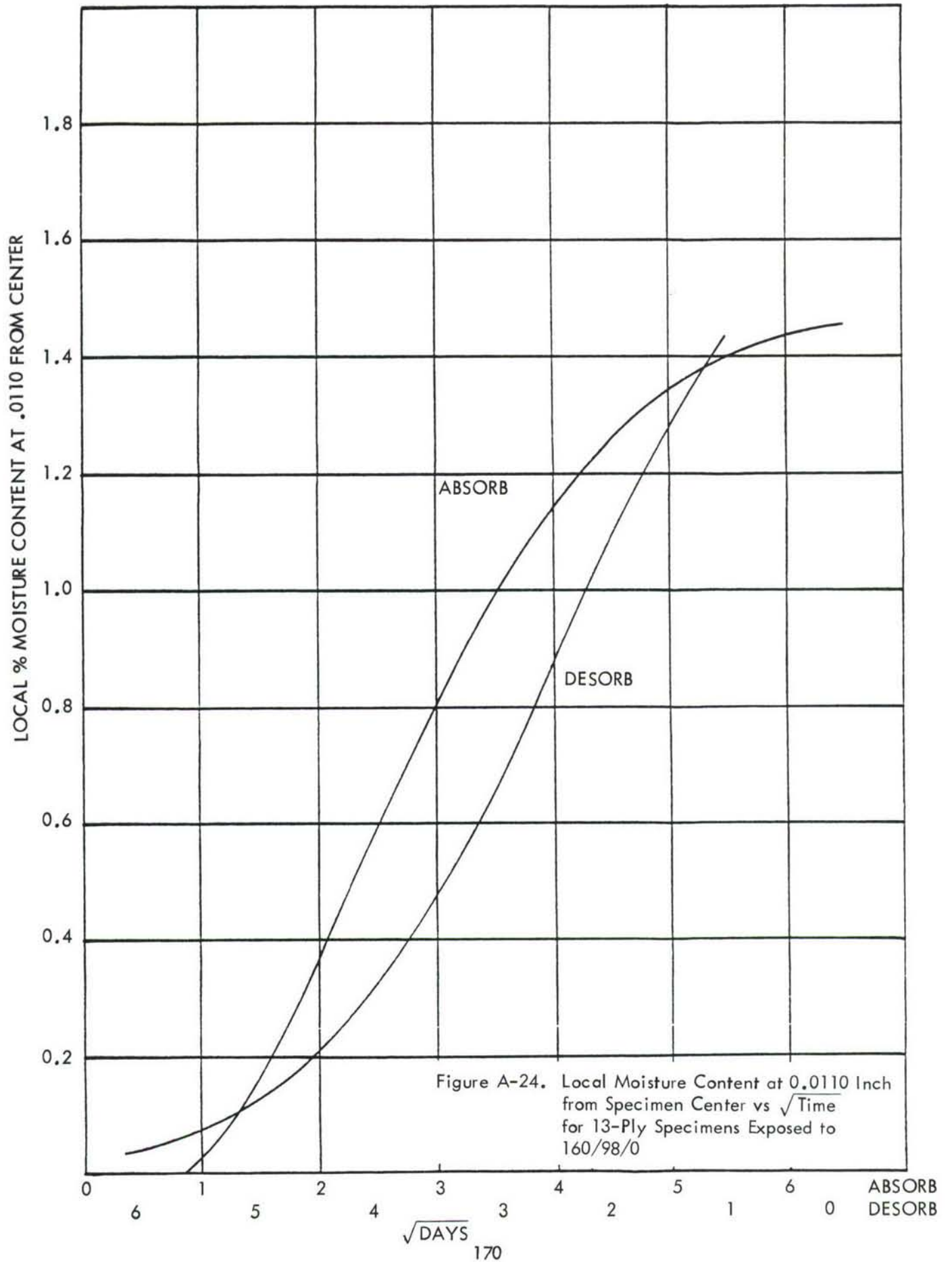
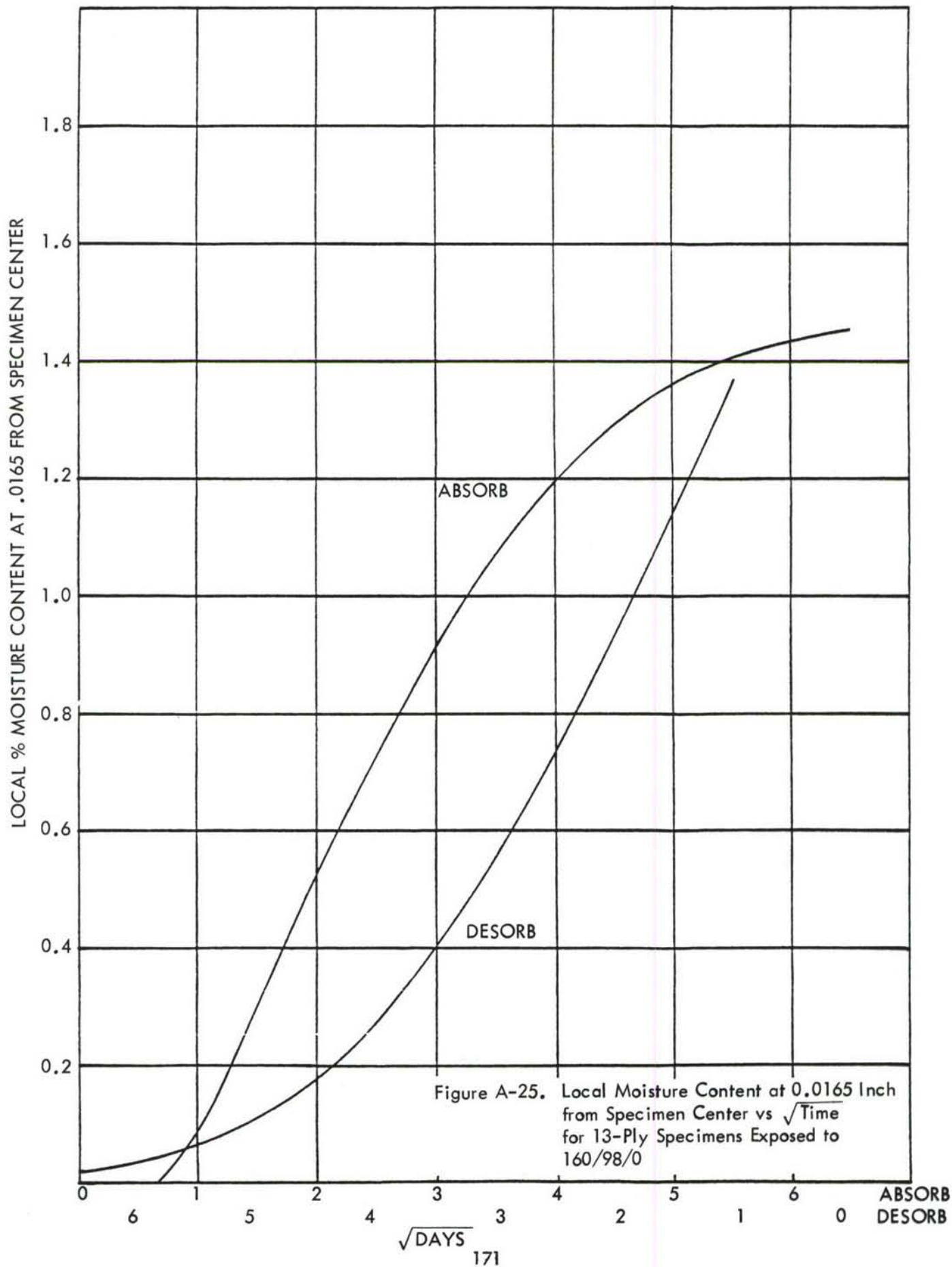

Figure A-23. Local Moisture Content at 0.0055 Inch from Specimen Center vs $\sqrt{\text{Time}}$ for 13-Ply Specimens Exposed to 160/98/0





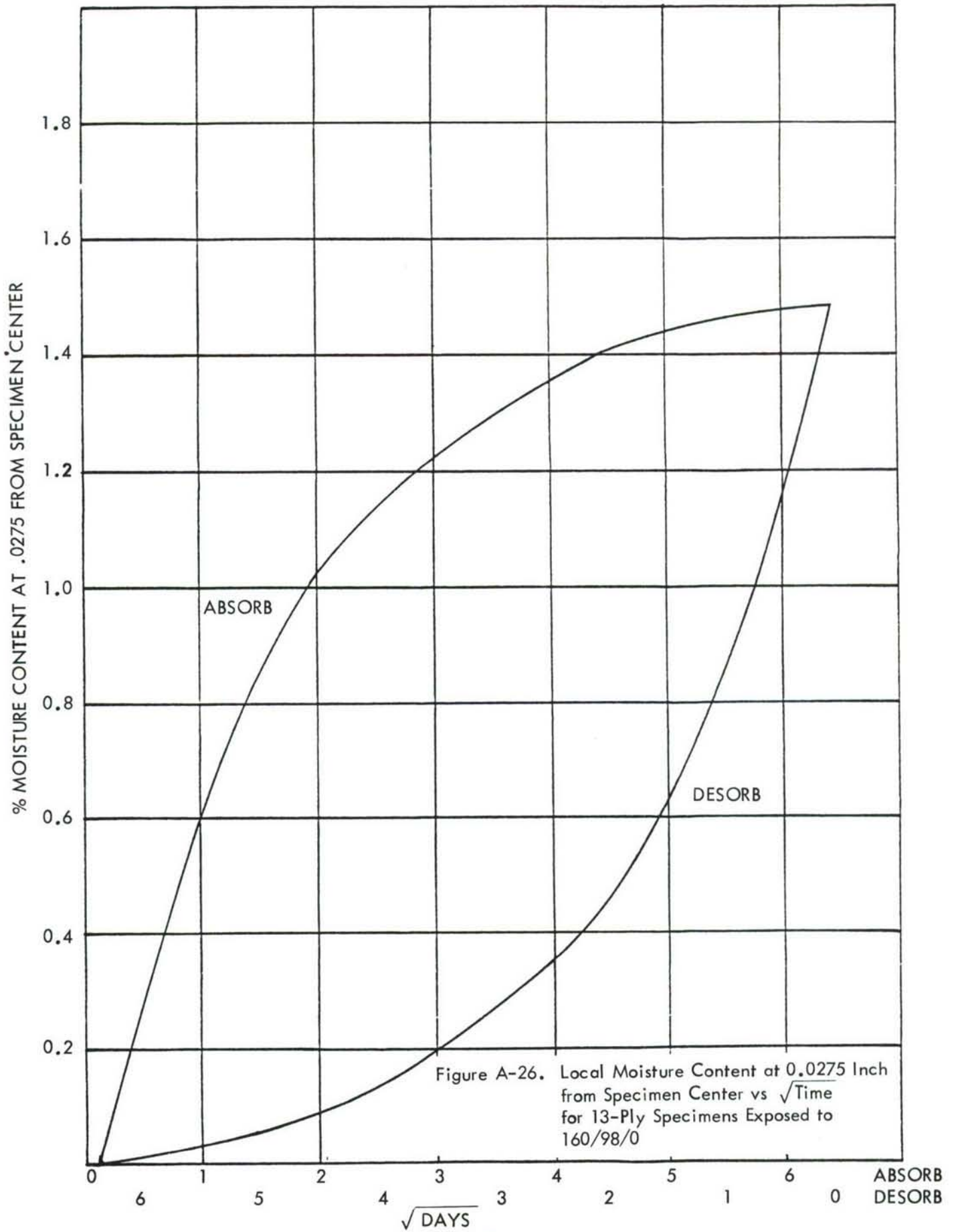

Figure A-26. Local Moisture Content at 0.0275 Inch from Specimen Center vs $\sqrt{\text{Time}}$ for 13-Ply Specimens Exposed to 160/98/0