

ARL
89555-3
H/S
①

LEVEL #

AD A100050

APPLIED RESEARCH LABORATORIES
THE UNIVERSITY OF TEXAS
AT AUSTIN

31 May 1977

Copy No. 1

SONAR TEST AND TEST INSTRUMENTATION SUPPORT
Quarterly Progress Report No. 3 under Contract N00140-76-C-6487
1 December 1976 - 28 February 1977

Dudley D. Baker et al.

NAVAL UNDERWATER SYSTEMS CENTER
Contract N00140-76-C-6487

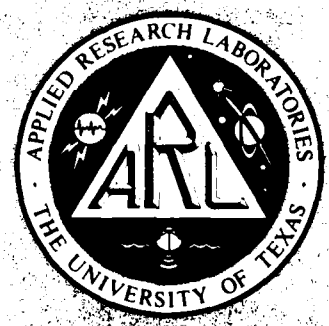

DTIC
ELECTE
JUN 11 1981
S D A

WIC FILE COPY

Approved for public release; distribution unlimited.

81 6 11 093

ARL
89535-3
3

11
31 May 1977

12, 1977

SONAR TEST AND TEST INSTRUMENTATION SUPPORT.
Quarterly Progress Report No. 3 under Contract N00140-76-C-6487
1 December 1976 - 28 February 1977

Quarterly progress report no. 3 under 76-31
Feb 77

10) Dudley D. Baker et al.

NAVAL UNDERWATER SYSTEMS CENTER
Contract N00140-76-C-6487

APPLIED RESEARCH LABORATORIES
THE UNIVERSITY OF TEXAS AT AUSTIN
AUSTIN, TEXAS 78712

4047-4

DTIC TAB
Unannounced
Justification
By
Distribution/
Availability Codes
Dist

TABLE OF CONTENTS

	<u>Page</u>
I. INTRODUCTION	1
II. TRANSDUCER REPAIR FACILITY TEST SITE FIELD SUPPORT	3
A. Introduction	3
B. MX-9818/GQM-1 Adapter, Filling Fixture, Transducer	3
C. Transducer Positioning Systems	3
D. Pressure Vessel Stuffing Tubes	3
III. AN/FQM-10(V) SONAR TEST SET FIELD SUPPORT	5
A. Introduction	5
B. Support for NAVSHIPYD PTSMH	5
IV. AN/WQM-5 SONAR TEST SET FIELD SUPPORT	7
A. Introduction	7
B. AN/WQM-5, Ser A6	7
C. AN/WQM-5, Ser A11	7
D. AN/WQM-5, Ser A12	7
E. AN/WQM-5, Ser A18	8
F. AN/WQM-5, Ser A21	8
G. AN/WQM-5, Ser B1	8
V. SPECIAL PURPOSE PASSIVE SONAR SYSTEMS SUPPORT	9
VI. SONAR INSTRUMENTATION TEST AND EVALUATION	11
A. Introduction	11
B. AN/SQM-() Test Set	11
VII. ASSISTANCE WITH EXPANSION OF TRF CAPABILITIES TO INCLUDE NEW TRANSDUCERS	13
A. Introduction	13
B. Liaison at NAVSEA	13
C. Liaison with CID and NAVSHIPYD PTSMH	13
D. Repair and Test Analyses	15
VIII. DOCUMENTATION SUPPORT	17
A. Introduction	17
B. Revision of the "Sonar Dome Handbook, Volume V, Submarine Sonar Domes," NAVSEA 0967-LP-412-3050	17

	<u>Page</u>
VIII. C. Revision of the "Sonar Dome Handbook, Volume II, AN/SQS-26 Steel and Rubber Sonar Domes," NAVSEA 0967-LP-412-3020	17
D. Revision of the "Sonar Dome Handbook, Volume IV, AN/SQQ-23 Rubber Sonar Domes," NAVSEA 0967-LP-412-3040	18
IX. AN/WQM-5 PROCUREMENT AND FIELD CHANGE PROGRAM	19
A. AN/WQM-5 Series Field Change Kits	19
B. Procurement of the AN/WQM-5A Sonar Test Sets for Spain	20
X. AN/BQQ-5 SWITCHING POWER SUPPLY	21
A. Introduction	21
B. Basic ARL:UT Design	21
1. Input Rectifier and Filter	21
2. Linear Housekeeping Supply	22
3. Housekeeping Control	22
4. Switching Control	22
5. Switching Modules	22
6. Output Capacitors	23
7. Series Dissipative Regulators	23
C. Model Testing	23
APPENDIX	25

I. INTRODUCTION

Applied Research Laboratories, The University of Texas at Austin (ARL:UT), was awarded Contract NO0140-76-C-6487, sponsored by the Naval Underwater Systems Center, New London Laboratory (NUSC/NL), effective 1 June 1976. Some of the work under this contract represents a follow-on effort to previous work sponsored by NUSC/NL under Contract NO0140-74-C-6316.

The work under Contract NO0140-76-C-6487 is divided into six task areas that focus on technical support in areas of sonar technology:

- I. AN/FQM-10(V) Sonar Test Set Field Support
- II. Transducer Repair Facility Test Site Field Support
- III. AN/WQM-5 Sonar Test Set Field Support
- IV. Special Purpose Passive Sonar Systems Support
- V. Sonar Instrumentation Test and Evaluation
- VI. Study of Towed Line Array Acoustical Testing at Transducer Repair Facilities

This report is Quarterly Progress Report No. 3 under Contract NO0140-76-C-6487. Section headings in this report correspond to the six task areas. Additional sections are included on documentation support, procurement of AN/WQM-5 components and field change kits, and AN/BQQ-5 power supply development.

II. TRANSDUCER REPAIR FACILITY TEST SITE FIELD SUPPORT

A. Introduction

ARL:UT provides material and technical support for the Transducer Repair Facility (TRF) test sites at three Naval shipyards: NAVSHIPYD PTSMH, NAVSHIPYD MARE, and NAVSHIPYD PEARL.

This work is partially a continuation of previous efforts at ARL:UT under Contract NO0140-74-C-6316, Task 0001AA, and the quarterly progress reports issued under that contract are applicable references for the work under Contract NO0140-76-C-6487.

B. MX-981E/GQM-1 Adapter, Filling Fixture, Transducer

No progress has been reported on this project during this report period because of the difficulty of procuring parts.

C. Transducer Positioning Systems

Design work on these systems has been completed. Some of the items for which ARL:UT is responsible have been completed; others are still being made. Most of the purchased items have been received. Final assembly and testing have been delayed until the dc motors have been received.

D. Pressure Vessel Stuffing Tubes

The TRFs at NAVSHIPYD MARE and NAVSHIPYD PEARL have received from ARL:UT 52 pressure vessel stuffing tube assemblies and two spanner wrenches. Each assembly has a basic body, two size No. 3 inserts, two size No. 3 nuts, two size No. 4 inserts, and two size No. 4 nuts.

The pressure vessel stuffing tube assemblies for NAVSHIPYD PTSMH are under construction at the present time.

III. AN/FQM-10(V) SONAR TEST SET FIELD SUPPORT

A. Introduction

ARL:UT provides material and technical support for six AN/FQM-10(V) sonar test sets located at three Naval shipyards with Transducer Repair Facilities (TRFs): Portsmouth Naval Shipyard (NAVSHIPYD PTSMH) at Portsmouth, New Hampshire; Mare Island Naval Shipyard (NAVSHIPYD MARE) at Vallejo, California; and Pearl Harbor Naval Shipyard (NAVSHIPYD PEARL) at Pearl Harbor, Hawaii. In addition ARL maintains a pilot AN/FQM-10(V) at its Lake Travis Test Station (LTTS).

This work is a continuation of previous efforts at ARL:UT under Contract N00126-72-C-1748 and Contract N00140-74-C-6316, Task 000LAA. Quarterly progress reports issued under those contracts are applicable references for the present work.

During this report period, ARL:UT has provided support for the test sets as described in the following subsection.

B. Support for NAVSHIPYD PTSMH

Upon request, ARL:UT furnished the TRF at NAVSHIPYD PTSMH with the following:

- (1) two diodes (FJT 2000) to be used on the input to the Scientific Atlanta model 1116 differential amplifiers, unit No. 6,
- (2) ten 220 pF capacitors to be used in the detectors of the Scientific Atlanta recorders,
- (3) six transistors (2N3055) to be used in Scientific Atlanta PVIM samplers, unit No. 30, and
- (4) one 1.0 to 2.6 multiplier switch for the Scientific Atlanta PVIM range selector, unit No. 29.

IV. AN/WQM-5 SONAR TEST SET FIELD SUPPORT

A. Introduction

Naval Sea Systems Command (NAVSEA) assigned ARL:UT the responsibility of being the designated overhaul point (DOP) for repairing AN/WQM-5 components. In addition to being the DOP, ARL:UT also provides field maintenance engineering support for the 27 AN/WQM-5 Sonar Test Sets located at various Naval shipyards, laboratories, and support activities.

During this report period, ARL:UT has provided support for several of the test sets, as described in the following subsections.

B. AN/WQM-5, Ser A6

ARL:UT furnished NAVSHIPYD LBEACH with one printed circuit (P.C.) board No. 1A7 in exchange for their P.C. board No. 1A7, which had failed.

C. AN/WQM-5, Ser A11

ARL:UT has completed repairs on the Ser A11 signal generator, unit No. 3, and shipped it to COMPACAREA COGARD in San Francisco. ARL:UT's Ser A8, unit No. 3, has been received from COMPACAREA COGARD, where it had been on loan.

D. AN/WQM-5, Ser A12

ARL:UT received, repaired, and returned Ser A12, units No. 7 and No. 8, to NAVSECNORDIV. When the units were powered at NAVSECNORDIV, two P.C. boards No. 7A3 failed. ARL:UT sent two P.C. boards No. 7A3 as replacements.

Continuing problems made it necessary to ship units No. 7 and No. 8 back to ARL:UT for repair and close observation. NAVSECNORDIV is now using ARL:UT's Ser A8 power supply and power amplifier.

E. AN/WQM-5, Ser A18

One P.C. board No. 1A7 was sent to NAVSHIPYD NORVA upon request. ARL:UT sent their Ser A8 unit No. 1 to NAVSHIPYD NORVA after other problems with the Ser A18 unit No. 1 were discovered.

F. AN/WQM-5, Ser A21

Upon request, ARL:UT provided MOTU 5, San Diego, with one transformer assembly (Tektronix part No. 120-0715-00) for their unit No. 4. New problems were encountered and at present ARL:UT is repairing the Ser A21 oscilloscope while MOTU 5 is using ARL:UT's Ser A8 oscilloscope.

G. AN/WQM-5, Ser B1

Unit No. 4 from the Ser B1 test set was repaired at ARL:UT and returned to MOTU 4 in Groton, Connecticut. MOTU 4 returned ARL:UT's Ser A8 oscilloscope, which had been loaned to them.

V. SPECIAL PURPOSE PASSIVE SONAR SYSTEMS SUPPORT

ARL:UT has completed a frequency domain equalizer (FDE) parameter study and a fixed shaper equalization network computer simulation and parameter study during this quarter. This work was tasked to ARL:UT by Naval Underwater Systems Center, Ft. Lauderdale (NUSC/FL). The details of the results of this program are documented in an ARL:UT technical report, which is being prepared.

Mr. Jeff Barrett of NUSC/FL visited ARL:UT for two weeks in January 1977 for the purpose of monitoring and participating in ARL:UT's study.

VI. SONAR INSTRUMENTATION TEST AND EVALUATION

A. Introduction

ARL participated in two projects under this task. The first project was the first article testing, at the Lake Travis Test Station (LITS), of the AN/WQM-7 Sonar Test Set, previously called the Sonar Test and Evaluation Equipment (STEE). This project was completed during the last report period. The second project, described below, is the design of a replacement for the outdated AN/SQM-5 Sonar Noise Recorder.

B. AN/SQM-() Test Set Engineering Model Evaluation

ARL:UT completed work on the design and construction of a breadboard model of the AN/SQM-5 replacement on 3 December 1976. By that date sufficient software had been developed and tested to ensure that the breadboard configuration could perform all necessary functions required for system evaluation.

On 7-9 December 1976, ARL:UT personnel, with the help of NAVSECNORDIV, successfully interfaced the AN/SQM-() to an AN/SQS-23G sonar system at NAVSECNORDIV. For the initial evaluation, all tests were performed in parallel with an AN/SQM-5 Sonar Noise Recorder that was in top operating condition. At-sea noise recordings were used to provide input signals to the AN/SQS-23G.

The initial testing of the AN/SQM-() verified that the unit can accurately control and/or track AN/SQS-23G synchronized signals, amplify and detect true rms low level sonar signals, and plot signal level versus bearing. Comparison of the control and measurement capabilities of the AN/SQM-() to those of the AN/SQM-5 demonstrated that the new unit can

easily outperform the AN/SQM-5. Following completion of the initial operational test, the AN/SQM-() was retained at NAVSECNORDIV for further testing.

During the period 20-24 December 1976, NAVSECNORDIV personnel conducted extensive tests on the AN/SQM-(). Once again the instrument was tested using the AN/SQM-5 as the baseline reference. The results of the NAVSECNORDIV performance test indicated that the AN/SQM-() (1) far exceeds the performance of the AN/SQM-5, (2) meets all the specified requirements of ELEX-T-236, Addendum 1, of January 1976, and (3) contains additional functions that make the AN/SQM-() a powerful analytical measurement system. Field testing of the unit aboard ship by NAVSECNORDIV personnel will complete the test and evaluation cycle for the breadboard unit.

On 24-25 January 1977, ARL:UT personnel demonstrated the AN/SQM-() breadboard model to NAVELEX representatives at NAVSECNORDIV. Improvements were also made to the software in preparation for the field testing of the unit. Current plans are to field test the AN/SQM-() aboard ship in mid-March 1977.

Current work on the AN/SQM-() includes a careful examination of the hardware configuration. Great emphasis is being placed on reducing the size, weight, and cost of the system while maintaining the new measurement capabilities. A second prime consideration is designing the equipment in such a manner that, as the Navy's measurement requirements increase or change, the equipment can be easily expanded to provide the required test capabilities. A technical letter describing the AN/SQM-() expansibility concept is in the appendix.

VII. ASSISTANCE WITH EXPANSION OF TRF CAPABILITIES
TO INCLUDE NEW TRANSDUCERS

A. Introduction

ARL:UT originally worked under Contract N00024-75-C-6070 to technically assist NAVSEA with expanding the capabilities of the Navy's three TRFs to encompass several new kinds of transducers, most of which are towed line hydrophone arrays. NAVSEA's plan is to equip the TRFs by FY 79 for repairing and testing the towed line arrays used with the following sonar systems: AN/BQQ-5, AN/BQQ-6, AN/SQR-18 (IETAS), AN/SQR-19 (ETAS), and AN/BQR-25 (STASS). In addition to these towed arrays, the plan includes equipping the TRFs to repair the transducers associated with the AN/WQM-6 Standard Acoustic Target Source (SATS) and the AN/WQM-7 equipment.

B. Liaison at NAVSEA

Visits were made by ARL:UT personnel in December 1976 to each NAVSEA sponsor responsible for the Navy's towed line arrays to acquaint them with the role of ARL:UT in providing the TRFs with repairing and testing capabilities. Estimates of special test and calibration requirements, kinds and numbers of arrays presently in service, and future requirements were obtained from each sponsor. Figure 1 shows ARL:UT's tasks, which are required by the end of FY 78.

C. Liaison with CID and NAVSHIPYD PTSMH

ARL:UT personnel visited the Chesapeake Instrument Division (CID) of Gould, Inc., the contractor for the TB-16/BQ and DT-582/BQR-25 (STASS) towed line arrays. The fabrication and testing of the towed arrays were observed. Facility layout and special handling and test equipment were noted during this tour.

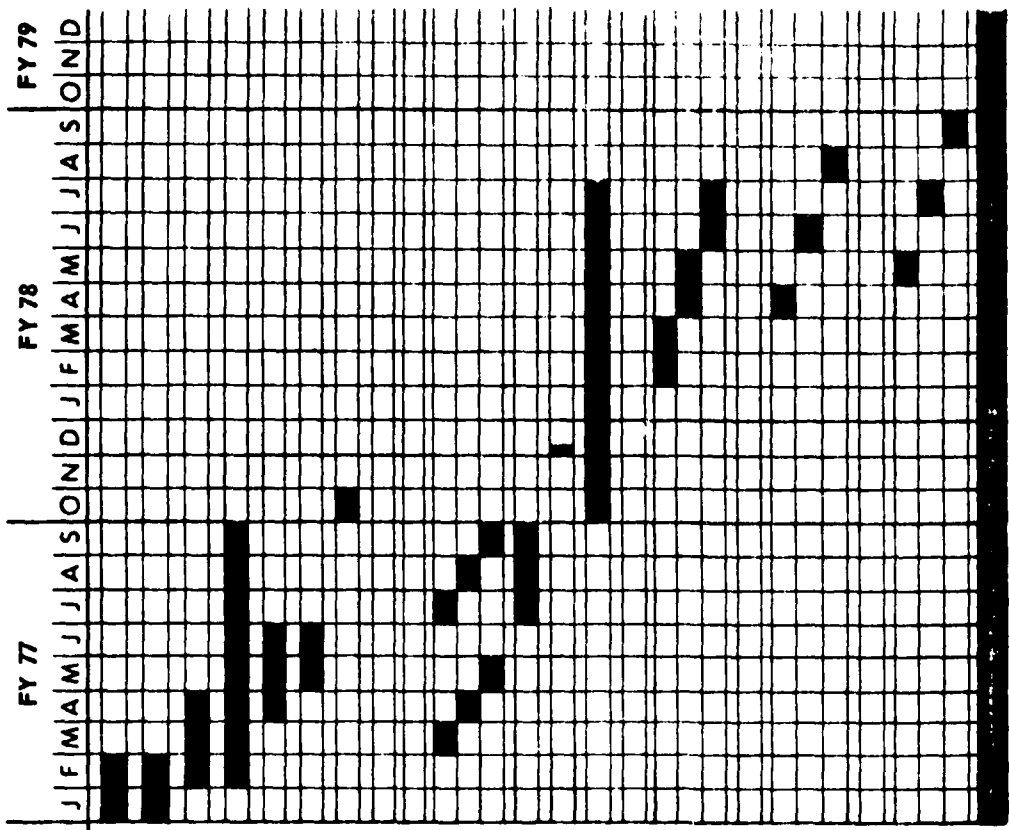

TASK

1. REVIEW TEST REQUIREMENTS FOR SONAR TOWED ARRAYS
2. REVIEW ACCEPTANCE/REJECTION CRITERIA FOR TOWED ARRAYS
3. ASCERTAIN SIMILARITY OF TEST EQUIPMENT REQUIRED
4. ASCERTAIN TEST EQUIPMENT REQUIRED
5. ASCERTAIN TEST FACILITIES NECESSARY
6. REVIEW REPAIR PROCEDURE DOCUMENTATION
7. DOCUMENT TEST INSTRUMENTATION REQUIRED
8. ASCERTAIN MOST EFFICIENT FACILITY LAYOUT TO ACCOMMODATE SONAR TOWED ARRAYS
 - (a) PTSMH
 - (b) MARE
 - (c) PEARL
9. PROVIDE FACILITY SPECIFICATIONS FOR TRFS
10. OBTAIN FACILITY EQUIPMENT FUNDS FROM SEA 07
11. PROCURE, RECEIVE¹ AND FABRICATE REPAIR AND TEST EQUIPMENT
12. PROVIDE FACILITY LAYOUTS FOR TRFS
 - (a) PTSMH
 - (b) MARE
 - (c) PEARL
13. INSTALLATION AND CHECKOUT OF TEST EQUIPMENT
 - (a) PTSMH
 - (b) MARE
 - (c) PEARL
14. PROVIDE TRAINING
 - (a) PTSMH
 - (b) MARE
 - (c) PEARL
15. SUPPORTING RESEARCH AND DEVELOPMENT EFFORT

¹ MILESTONES DEPEND ON PROMPT DELIVERY OF EQUIPMENT BY MANUFACTURERS

FIGURE 1
MILESTONES FOR NAVSEA TOWED LINE ARRAY REPAIR AND TEST CAPABILITY FOR TRFS

The TRF at NAVSHIPYD PTSMH was visited during the same trip to review the work area that may be used. A new building is planned by FY 79. In response to ARL:UT's role in monitoring the construction of the new building, ARL:UT forwarded to NAVFACNORTHDIV building floor space allocations to facilitate the repair of towed line arrays.

Details of ARL:UT travel to NAVSEA, CID, and NAVSHIPYD PTSMH will be documented in an ARL:UT trip report.

D. Repair and Test Analyses

A review of the AN/BQQ-5 and 6 and STASS towed line array test requirements was completed during this quarter. Analyses of the repair and testing facilities indicate that the restoration flowchart shown in Fig. 2 is applicable to each array. A preliminary facility layout was made for the towed line array repairs at each TRF. Repairs of towed line arrays can be done most efficiently by assigning areas for each phase of the array repair and testing. Arrays with modules under 12 m (40 ft) in length can be repaired using the same work areas. Longer array modules will be repaired on a long workbench, such as the length used in the AN/SQR-18 repairs, and will be assigned their own repair area.

During the next quarter, completing the facility layout study and beginning a list of test equipment required for each array are planned.

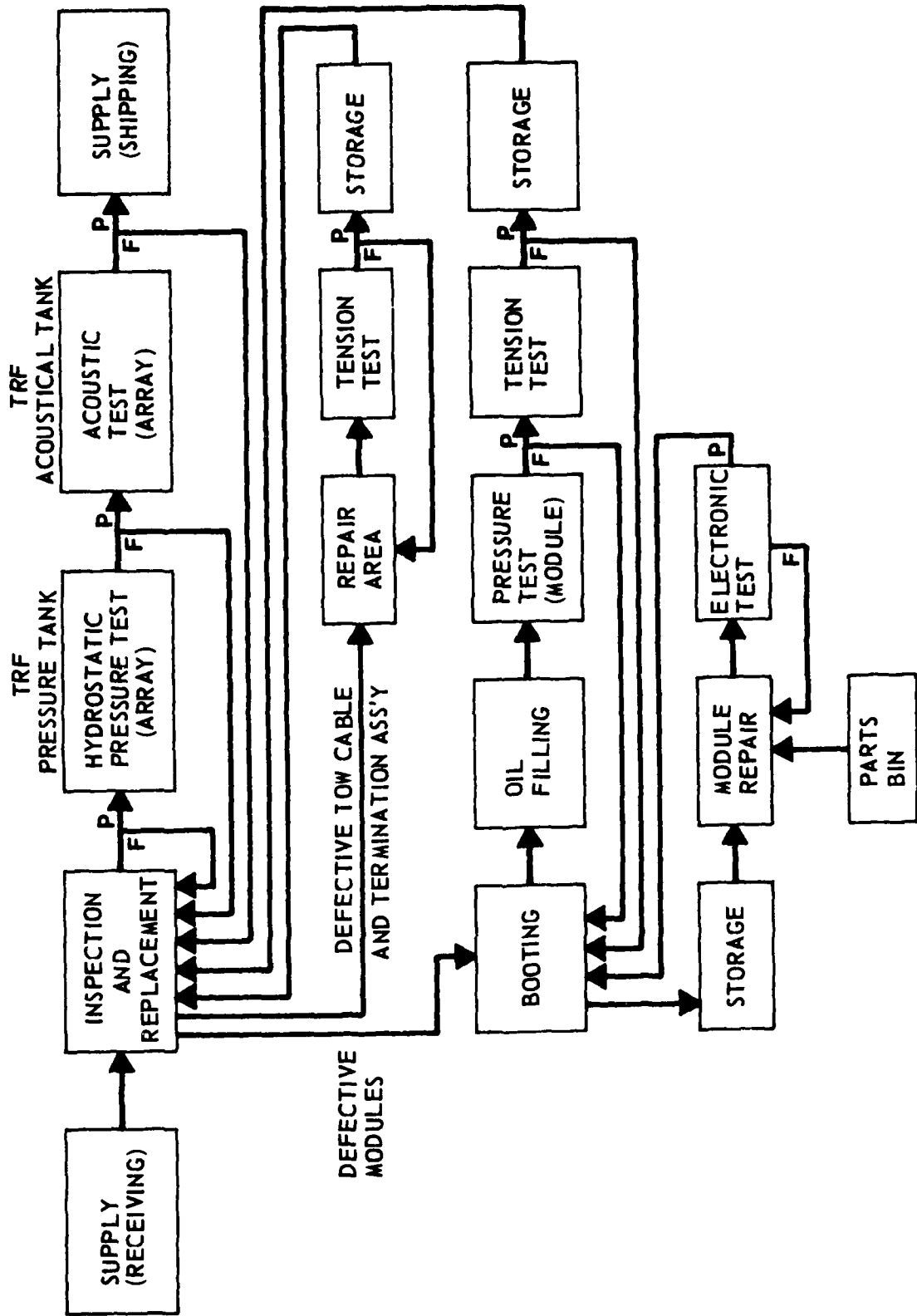

FIGURE 2
TOWED LINE ARRAY TRF REPAIR FLOW CHART

ARL - UT
AS-77-637
GEE - JRB
6-16-77

VIII. DOCUMENTATION SUPPORT

A. Introduction

ARL:UT participated in three tasks in the area of documentation support, which focused on producing the Sonar Dome Handbook.

B. Revision of the "Sonar Dome Handbook, Volume V, Submarine Sonar Domes," NAVSEA 0967-LP-412-3050

Processing the new material for "Sonar Dome Handbook, Volume V, Submarine Sonar Domes" was completed in December and the Handbook was submitted to NAVSEC Code 6010E01 (Mr. P. G. Gauthier) for approval by ARL ltr Ser E-270 of 22 December 1976. By telephone conversation with Mr. Gauthier on 10 January 1977, the Handbook was approved for publication as written, with minor corrections. Also on 10 January, 450 vinyl plastic covers in the same style used on previous Handbooks were ordered, and writing the index and bibliography was started. Printing started on 24 January, and printing and collating were completed on 18 February. When the covers arrived on 18 February, they were the wrong size. Replacement of the incorrect covers by the vendor is expected within a few weeks. The distribution letter from NAVSEA and an updated distribution list are also expected shortly.

C. Revision of the "Sonar Dome Handbook, Volume II, AN/SQS-26 Steel and Rubber Sonar Domes," NAVSEA 0967-LP-412-3020

Three copies of the manuscript for Volume II of the Sonar Dome Handbook (NAVSEA 0967-LP-412-3020) were sent to NAVSECNORDIV on 7 December 1976 for review and comment. These comments were received on 22 February 1977. At the present time these revisions, which include a new chapter 4 on the transducer array assembly on DD 963 class ships, are being

incorporated in the manuscript. It is anticipated that this document will be printed and distributed during the next report period.

D. Revision of the "Sonar Dome Handbook, Volume IV, AN/SQ-23 Rubber Sonar Domes," NAVSEA 0967-LP-412-3040

On 12 November 1976, two copies of the manuscript for Volume IV of the Sonar Dome Handbook (NAVSEA 0967-LP-412-3040) were sent to NAVSECNORDIV for review and comment. These comments have been received and all corrections have been made to the manuscript. 200 copies, including 60 copies for NAVPUBFORMCEN PHILA, have been printed and distributed during this report period.

IX. AN/WQM-5 PROCUREMENT AND FIELD CHANGE PROGRAM

A. AN/WQM-5 Series Field Change Kits

On 2 December 1976, ARL:UT signed an OEM agreement with Hewlett-Packard, Inc., for the off-the-shelf programmable calculators and plotters to be incorporated into the AN/WQM-5 Field Change Kits. Limited quantities of these items were ordered shortly thereafter and several calculators were at ARL:UT by 28 February 1977. In February 1977, a new state-of-the-art plotter, model No. 9872A, was announced by Hewlett-Packard. Fortunately, ARL:UT had not completed procurement action on the HP model No. 9862A plotter that was planned for incorporation in the field change kit. The HP model No. 9872A will be used in the AN/WQM-5C Field Change Kits in place of its predecessor.

Work at C-Tech, Inc., was in progress during the entire report period, mainly on procurement of the parts necessary to fabricate the other field change kit components, which C-Tech, Inc., will manufacture for ARL:UT. ARL:UT is planning to begin work on the technical manuals for the field change kits in the near future, but this effort has not begun.

On 10 January 1977, ARL:UT officially received the military nomenclature on the AN/WQM-5 test sets as they will be configured after incorporation of the field change kits. The proposed nomenclatures AN/WQM-5A, B, and C were approved. Unit nomenclature was also obtained on all of the eight new kinds of units that will be installed in the field change kits.

B. Procurement of the AN/WQM-5A Sonar Test Sets for Spain

Work was under way on this unit during the entire report period. The original AN/WQM-5 components for this unit have been ordered from Dranetz Engineering Laboratories and work is under way on their manufacture. Delivery is expected near the end of March 1977. The new components, which constitute an AN/WQM-5A Field Change Kit, are on order from C-Tech, Inc., and Hewlett-Packard. It is expected that these units will not be delivered until late spring 1977.

X. AN/BQQ-5 SWITCHING POWER SUPPLY

A. Introduction

ARL:UT was tasked under Contract N00024-74-C-1069 by NAVSEA Code 660F to perform a study of the current switching power supply (built by IBM) which is used in the AN/BQQ-5 sonar system. This basic study has progressed to a new design proposed by ARL:UT that should make the reliability requirement of 100,000 h MTBF a reality.

The work under Contract N00140-76-C-6487, a follow-on task to the original study, requires ARL:UT to fabricate and demonstrate a model of the proposed new supply.

B. Basic ARL:UT Design

The ARL:UT design has been divided into functional modules which will be explained in the following order: (1) input rectifier and filter, (2) linear housekeeping supply, (3) housekeeping control, (4) switching control, (5) switching modules (four), (6) output capacitors, and (7) series dissipative regulators.

1. Input Rectifier and Filter

The input rectifier and filter contains an EMI filter; an integrated, 15 A, 3-phase, 600 V bridge rectifier; and five paralleled filter capacitors. The 3-phase input line is fused and each of the filter capacitors is fused. The capacitors have a redundancy built in, which allows a failure to occur without a power supply shutdown. In paralleling capacitors a good conformal shape is obtained as a benefit.

2. Linear Housekeeping Supply

The linear housekeeping supply is a doubly redundant circuit. Two linear, 6 VA, 115 Vac printed-circuit-mounted transformers are summed together with fuses, and individual bridge rectifiers and capacitors are isolated by fuses, with the result that any part can fail and the supply will still operate properly. The housekeeping voltage (10 Vdc to 16 Vdc) linearly follows the input voltage and provides a tracking signal for the switching control board.

3. Housekeeping Control

The housekeeping control board determines the status of the supply regarding overvoltage, undervoltage, overcurrent, and thermal overtemperatures. There is also a turn-on delay associated with undervoltage.

4. Switching Control

The switching control board circuitry is based upon an integrated circuit, the SG1524, built by Silicon General Corporation. Contained within the chip are a pulsewidth modulator for the switching drive signal, an internal oscillator, an error amplifier, and an adaptable output drive. Four SG1524s are used, although only two are needed; thus, a two out of four redundancy is provided.

5. Switching Modules

The four switching modules are the heart of the system since they must isolate the supply from the line in addition to handling the output power. Each of the four modules is linked to a specific SG1524 on the switching control board. Even if two of the switching modules fail, the supply will still operate. The two out of four redundancy should improve reliability.

6. Output Capacitors

The output capacitors absorb the energy "dumped" into them by the switching modules. The type of capacitors used must handle high ripple currents and have a low output impedance and ESR (total series impedance). Several capacitors are paralleled to provide a lower output impedance, a better conformal shape, and redundancy. The redundancy is obtained by inserting a series fuse in each capacitor such that a shorted capacitor opens the fuse and takes itself out of the circuit.

7. Series Dissipative Regulators

The series dissipative regulators are used to reduce the switching noise inherent in switching power supplies. These regulators have three requirements that make the design difficult: (1) they must work at low input-to-output voltages for high efficiency, (2) the output current is high, and (3) current foldback requires a special current-sense resistor and additional circuitry.

Reliability tradeoffs have not been completed at this time, but the ARL:UT design maximizes the redundancy. Most switching power supply designs are not suited for redundancy.

C. Model Testing

ARL:UT is currently testing a complete engineering model, except for main loop current shutdown. Testing of the model will be demonstrated for NAVSEA at ARL:UT on 5-6 April 1977. Details, engineering drawings, and the results of the thermal cycling to be done on the power supply will be documented in the next progress report.

APPENDIX
AN/SQM-() EXPANSIBILITY

PRECEDING PAGE BLANK-NOT FILLED



THE UNIVERSITY OF TEXAS AT AUSTIN APPLIED RESEARCH LABORATORIES



mailing address:
POST OFFICE BOX 8029
AUSTIN, TEXAS 78712

phone: (512) 836-1351

shipping address:
10000 FM ROAD 1325
AUSTIN, TEXAS 78758

5 January 1977
TL-EA-77-1

AN/SQM-() EXPANSIBILITY

T. K. Butler
J. L. Shorey
J. J. Truchard

The use of an HP 9825A or equivalent calculator as the control of computation element for the AN/SQM-5 replacement, in addition to providing the Noise Recorder with capabilities that vastly exceed the existing AN/SQM-5, allows the test instrument to be easily and economically expanded to perform other essential test functions. The I/O structure is highly versatile allowing the calculator to communicate with external instruments in 16-bit binary, Binary Coded Decimal (BCD), RS232 (Serial ASCII), or Byte Serial, bit parallel (IEEE 488-1975) formats. As a result, the calculator can be plugged directly into a large number of existing test instruments. In particular, a growing number of instruments having internal processor capability and compatibility with the IEEE 488 interface structure have recently become available. As a result, the AN/SQM-5 could eventually be expanded to include as many as 14 devices with minimum added engineering costs.

An example of how the AN/SQM-5 replacement could easily be expanded to include measurements on complex sonar systems is shown in Fig. 1. The expanded configuration would enable the test set to perform such tests as bearing accuracy, realtime spectral analysis of sonar signals, 1/3 octave or one octave analysis, automatic transient capture and gain-phase analysis. Using off the shelf equipment, the configuration shown in Fig. 1 could provide the following capabilities:

PRECEDING PAGE BLANK-NOT FILLED

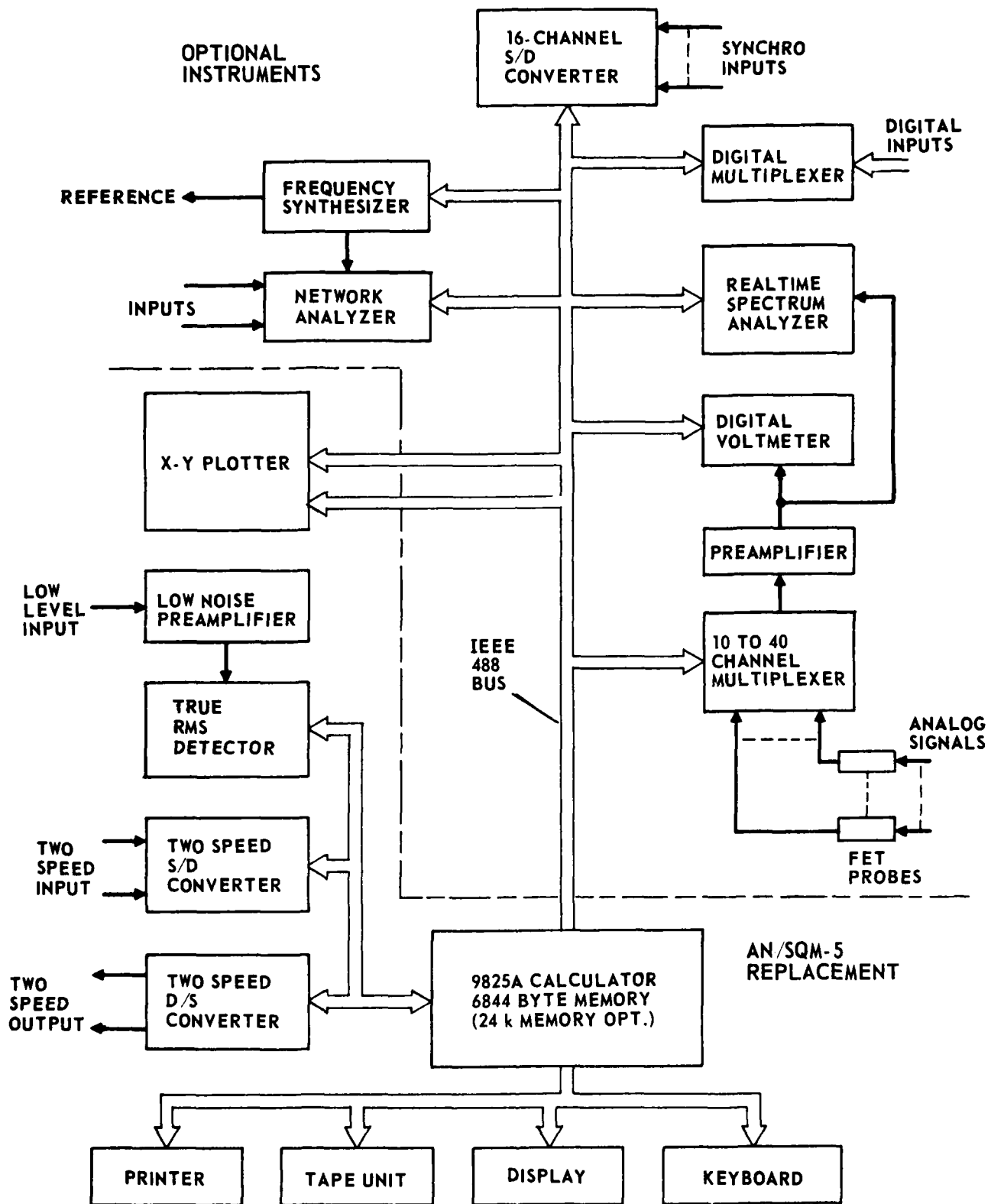

FIGURE 1

1. Multiplex capability for up to 40 low level analog signals. Low noise, high input impedance probes would be used.
2. Amplification of the selected signal with a high quality, low noise preamplifier.
3. rms or True rms measurement of the broadband signal.
4. Narrowband octave and third-octave realtime spectrum analysis over a frequency range of dc to 100 kHz and an input signal dynamic range of 10 dB. The measurement capabilities of absolute amplitude, relative amplitude, frequency, harmonious sidebands, and true average power would be included. A built-in CRT would display either a single spectrum, two independent spectra, or a captured transient waveform.
5. A digital multiplexer would provide input/output capability to digital sonar equipment.
6. A 16-channel synchro converter would provide interface to various ships synchro signals. Sixteen one-speed or eight 2-speed synchro inputs would be accepted.
7. A frequency synthesizer provides a stimulus to various system components while a gain phase meter would measure the resulting response.

The capabilities listed above could be expanded by the addition of still more devices. The processing and display characteristics of the calculator could also be upgraded by the addition of more memory and/or peripherals. Devices such as CRT displays and external disc drives are standard options to the calculator.

By the use of a calculator for the control element in the AN/SQM-5 replacement, the measurement capabilities of the AN/SQM-5 will be greatly improved. The ability of the calculator to control numerous other complex instruments ensures that the test set will not become obsolete as future test requirements change. In addition, the existence of similar instruments from different manufacturers that are compatible with the IEEE 488 bus will ensure second sources for the replacement of various system components.

31 May 1977

DISTRIBUTION LIST FOR
QUARTERLY PROGRESS REPORT NO. 3
UNDER CONTRACT N00140-76-C-6487
1 December 1976 - 28 February 1977
FOR OFFICIAL USE ONLY

Copy No.

1 - 3	Receiving Officer Naval Underwater Systems Center New London Laboratory Building 45 New London, CT 06320 Attn: Code NA401
4	Office of Naval Research Resident Representative Room 582, Federal Building Austin, TX 78701
5	Electroacoustics Group, ARL:UT
6	Engineering Services Division, ARL:UT
7	Eugene Plum, ARL:UT
8	James R. Bryant, ARL:UT
9	Bill S. Shaw, ARL:UT
10	James J. Truchard, ARL:UT
11	Gary G. Warren, ARL:UT
12	Library, ARL:UT

THE UNIVERSITY OF TEXAS AT AUSTIN

Approved for public release; distribution unlimited



**DAT
FILM**