

AD A100309

LEVEL # 2

HDL-CR-81-029-1 ✓

March 1981

Sea Gnat Safety and Arming Device

by R. G. Eshleman

Prepared by

Hamilton Technology, Inc.
901 Columbia Avenue
Lancaster, PA 17604

Under contract

DAAG39-78-C-0029

DTIC
SELECTED
JUN 16 1981



A

**U.S. Army Electronics Research
and Development Command**

Harry Diamond Laboratories

Adelphi, MD 20783

DTIC FILE COPY

Approved for public release; distribution unlimited.

81 6 12 131

The findings in this report are not to be construed as an official Department of the Army position unless so designated by other authorized documents.

Citation of manufacturers' or trade names does not constitute an official indorsement or approval of the use thereof.

Destroy this report when it is no longer needed. Do not return it to the originator.

UNCLASSIFIED

SECURITY CLASSIFICATION OF THIS PAGE (When Data Entered)

REPORT DOCUMENTATION PAGE		READ INSTRUCTIONS BEFORE COMPLETING FORM
1. REPORT NUMBER HDL-CR-81-029-1	2. GOVT ACCESSION NO. AD-A100309	3. RECIPIENT'S CATALOG NUMBER
4. TITLE (and Subtitle) SEAGNAT SAFETY AND ARMING DEVICE		5. TYPE OF REPORT & PERIOD COVERED FINAL REPORT
7. AUTHOR(s) R. G. ESHLEMAN HDL Contacts: D. Overman and J. Carpenter		6. PERFORMING ORG. REPORT NUMBER
9. PERFORMING ORGANIZATION NAME AND ADDRESS HAMILTON TECHNOLOGY, INC. Box 4787 Lancaster, PA 17604		8. CONTRACT OR GRANT NUMBER(s) DAAG39-78-C-0029
11. CONTROLLING OFFICE NAME AND ADDRESS HARRY DIAMOND LABORATORIES 2800 Powder Mill Road Adelphi, MD 20783		10. PROGRAM ELEMENT, PROJECT, TASK AREA & WORK UNIT NUMBERS 62569N
14. MONITORING AGENCY NAME & ADDRESS (if different from Controlling Office)		12. REPORT DATE APR 1981
		13. NUMBER OF PAGES 26
		15. SECURITY CLASS. (of this report) Unclassified
		15a. DECLASSIFICATION/DOWNGRADING SCHEDULE
16. DISTRIBUTION STATEMENT (of this Report) Approved for public release; distribution unlimited		
17. DISTRIBUTION STATEMENT (of the abstract entered in Block 20, if different from Report)		
18. SUPPLEMENTARY NOTES DRCMS Code.N/A; Navy Research and Development HDL Project No. 421040		
19. KEY WORDS (Continue on reverse side if necessary and identify by block number) SEAGNAT Safety and Arming (S&A) device M429 fuze S & A device Piston Actuator MK96 Detonator		
20. ABSTRACT (Continue on reverse side if necessary and identify by block number) This report summarizes the design development and testing of a safety and arming (S&D) device for the NATO SEAGNAT time fuze. This S&A device is the result of modifications to the existing M429 safing and arming device. Three major changes were made to the M429 mechanism (1) the spring-mass system was changed to permit arming at 8 g's, (2) a single pole single throw switch was added. The switch closed at arming and was electrically isolated from the S&A and the outer housing, (3) the rotor is locked in the safe position to		

DD FORM 1473 EDITION OF 1 NOV 65 IS OBSOLETE

UNCLASSIFIED

SECURITY CLASSIFICATION OF THIS PAGE (When Data Entered)

1

UNCLASSIFIED

SECURITY CLASSIFICATION OF THIS PAGE(When Data Entered)

prevent movement prior to the launch signal. All performance and safety requirements were met as could be determined by the testing performed at Hamilton Technology.

The device is housed within an aluminum cylinder 1.515 in. dia. by 1.550 in. long with a 2.015 in. dia. mounting flange at one end. The safe or armed condition may be determined through a window at the top of the housing.

UNCLASSIFIED

SECURITY CLASSIFICATION OF THIS PAGE(When Data Entered)

TABLE OF CONTENTS

		<u>Page</u>
1	Introduction	5
2	Functional Description	5
3	Modifications to the M429 S&A	5
4	Operation of the SEAGNAT S&A Device	9
5	Development Program	10
	5.1 Design Requirements	10
	5.2 Design Requirements Satisfied	12
	5.3 Development Work Performed	13
	5.3.1 Escapement	14
	5.3.2 G-Sensing Components	17
	5.3.3 Housing	17
	5.3.4 Auxiliary Arming Switch	17
	5.3.5 Piston Actuator Housing	21
	5.3.6 HDL Proposed Revisions	21
6	Recommendations	22
Appendix A	Assembly and Loading Procedure for the SEAGNAT S&A (Modified M429 S&A) P/N 55491 Rev. D	23
Distribution		24

Accession For

MPD CRAM

DRG 718

Escapement

Installation

Availability Class

Avail and/or

Special

A

FIGURES

		<u>Page</u>
1	SEAGNAT Safety and Arming Device	7
2	M429 Safety and Arming Device	2
3	SEAGNAT Wiring Schematic	11
4	Original Drogue Switch Design	18
5	Final Drogue Switch Design	19

TABLE

1	Arming Times of Each Lot of S&A's	15
---	-----------------------------------	----

1. Introduction

This report describes the design and development of the SEAGNAT Safing and Arming (S&A) device for the NATO SEAGNAT time fuze.

This S&A device was derived from modifications to the existing M429 S&A device.

All S&A's were tested at 5 g for non-arming and at 8 g and 12 g for arming time.

2. Functional Description

The S&A device for the SEAGNAT fuze program is a modification of the M429 S&A device. Figure 1 shows an exploded view of the SEAGNAT fuze S&A and Figure 2 shows an exploded view of the M429 fuze S&A. The SEAGNAT S&A has an unbalanced rotor containing a MK96 electric detonator. The rotor is maintained out-of-line with an explosive lead charge by means of a spring biased g-weight and a mechanical lock which is disengaged by an electro explosive piston actuator. At launch, the piston actuator initiates, which removes the first mechanical lock and then the g-weight is driven aft unlocking the unbalanced rotor. Continued acceleration causes the rotor to turn under restraint of a runaway escapement and to eventually move the electric detonator into alignment with the lead charge. When the rotor is disconnected from the runaway escapement, it snaps into the armed position and is held there by a spring-biased detent within the escapement assembly. Functioning of this detent also closes an auxiliary arming switch attached to the escapement plate. Contacts on the rotor assembly make contact with switch blades mounted on the frame which connects the electric detonator to the firing circuit when the rotor is in the armed position.

3. Modifications to the M429 S&A

The following modifications were made to the M429 S&A to adapt it to the SEAGNAT program requirements (Fig. 1).

Rotor Weight (55457)

A brass weight was added to the notch in the rotor to provide increased torque because the SEAGNAT S&A has available to it a much lower g field than did the M429 S&A.

Escapement Assembly (55483)

The two pallet levers (03031) are made from aluminum. The pallet inertia was reduced to allow the rotor to arm faster.

Annular Gear (55459)

The annular gear on the rotor was modified by removing the last three teeth which engaged the No. 2 Pinion (03025) in the escapement assembly. This change reduces the time the rotor is engaged with the escapement assembly and allows the rotor to accelerate rapidly; this allows the buildup of sufficient energy to reliably detent the rotor while simultaneously depressing the 2 contact blades of Switch Assembly 03052.

Setback Weight Springs (55477)

The bias springs for the setback weight are redesigned to reduce the bias level and the force gradient in moving from the safe to the armed position. The M429 S&A device springs were designed to start motion of the g-weight at approximately 10 g and to require approximately 14 g to fully arm the g-weight. The corresponding values for the new SEAGNAT springs are approximately 5.6 to 7.4 g. Considerations here were to keep the bias level low to work under the low-g SEAGNAT rocket acceleration profile but above the level expected from vibration during transportation and shipboard storage. It is also desirable to have strong bias springs to reliably reset the rotor to the safe position in case the rocket acceleration pulse is not sustained for an adequate length of time. The only way in which the spring force can be increased while maintaining the same bias level is to use a heavier g-weight.

Piston Actuator Housing Assembly (55481)

The battery striker has been eliminated and the striker housing has been modified to contain a miniature piston actuator (1MT172-3/8). Output of the actuator pushes a piston which lifts Release Plate Assembly (55482), which interlocks with a pin projecting from the surface of the rotor. This interlock provides the second safety feature, in accordance with MIL-STD-1316B. The actuator is fired by the same signal that fires the rocket motor ignition squib. Thus the rocket is committed to launch at the time this first safety lock is removed. The striker housing contains an insulated plug-in connector for the actuator. A spring Washer (55465) and a spring pin in contact with the actuator body are used as a ground contacts. The piston and release plate assembly is staked in the housing using a controlled stake that requires a nominal 50 lb. force to push it out.

Auxiliary Arming Switch Assembly

A single pole single throw normally open switch was added to the S&A shortly after the contract began. The switch is mounted on the Outer Plate (55469) of the escapement assembly. The switch is actuated by the Rotor Detent (55471) which is made of plastic so as to electrically isolate the Pin Driver (55493) and Switch Contact (53474)

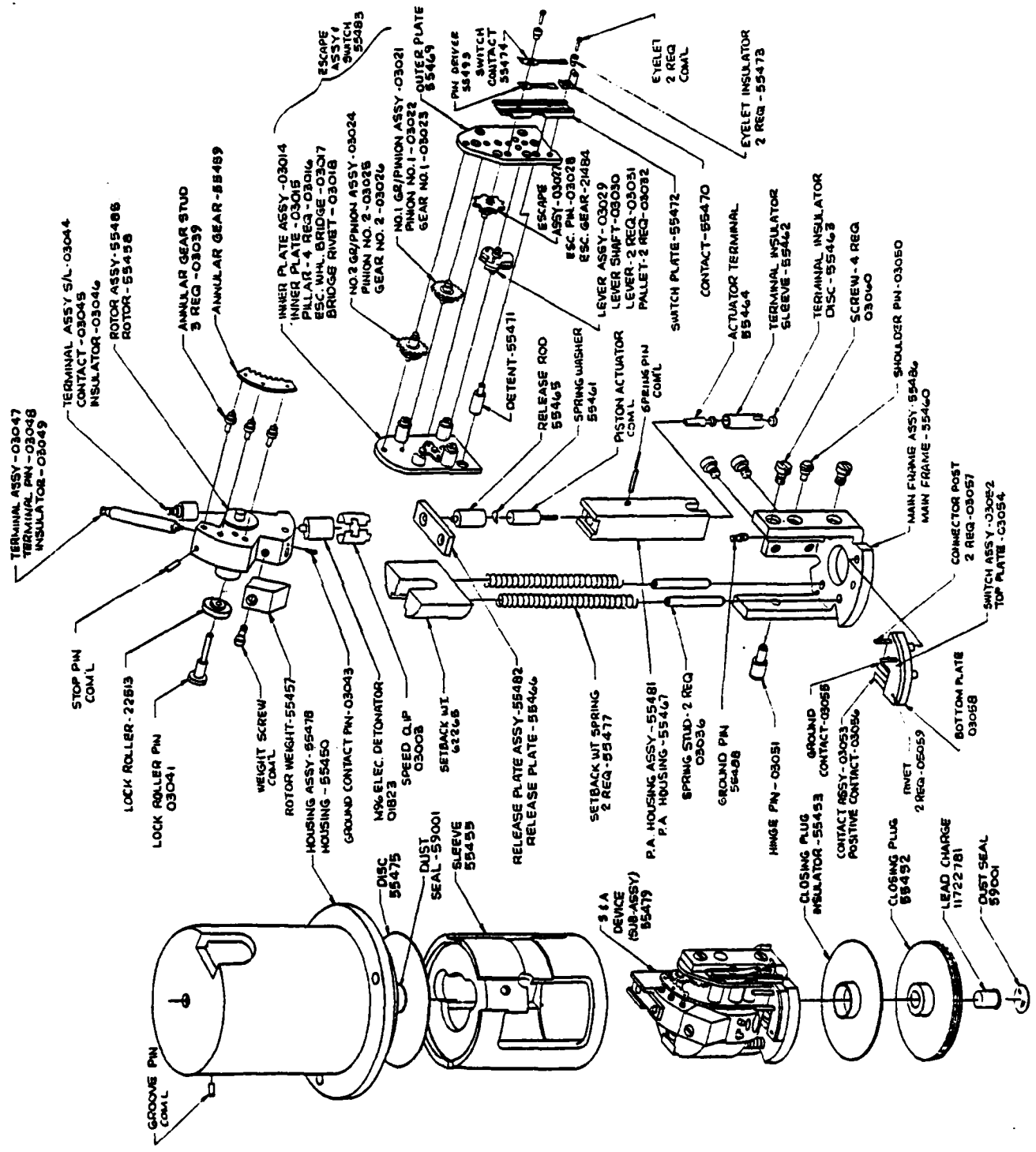

SEAGNAT SAFETY AND ARMING DEVICE

FIGURE 1

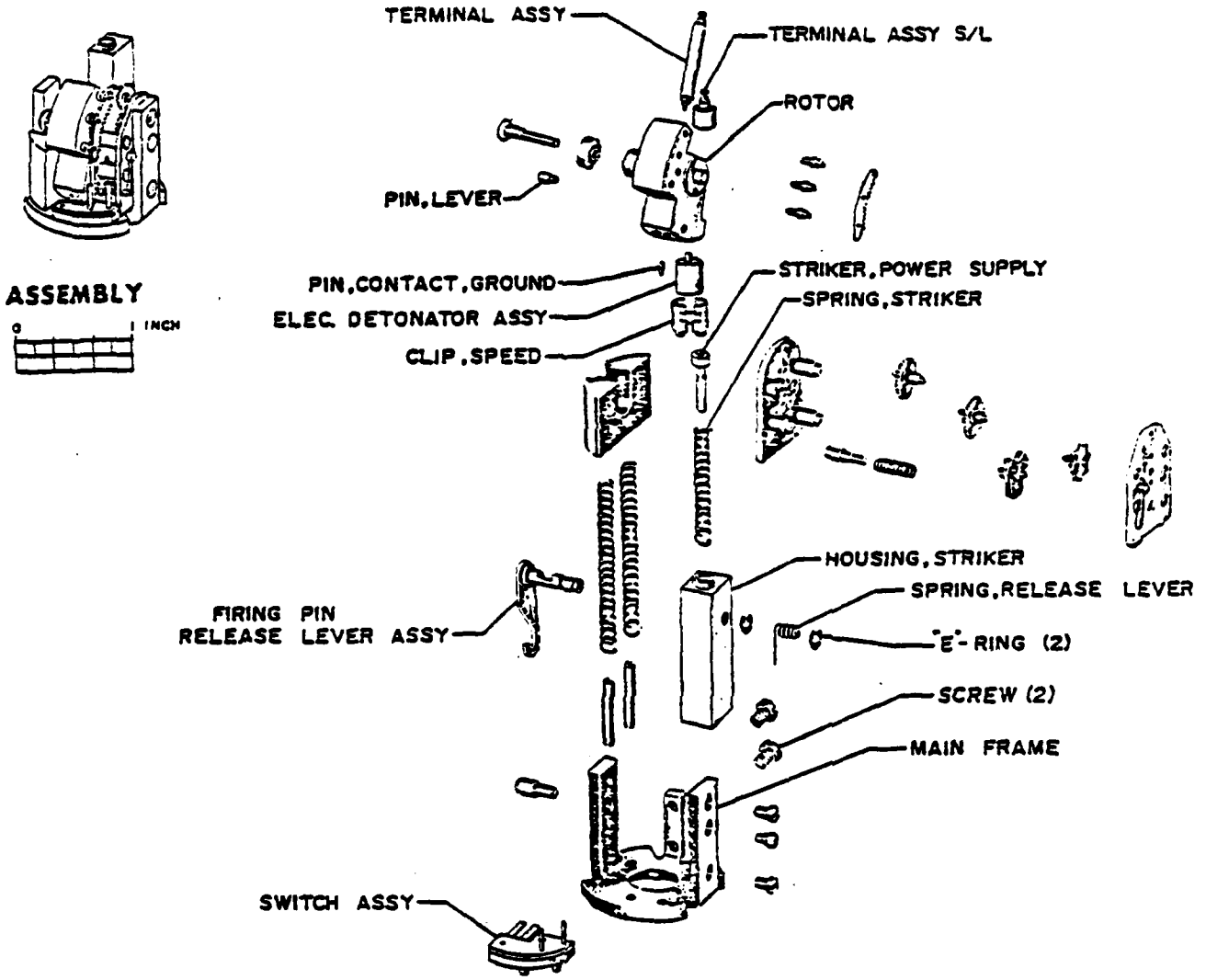

**SAFETY AND ARMING DEVICE
 M429 ROCKET FUZE**

FIGURE 2

from ground. The Pin Driver and Switch Contact are assembled in parallel with the Switch contact contacting the insulated Detent and tending to drive it into contact with the Rotor Assembly (55485). The drag on the Rotor produced by these two switch components is no more than that produced by the original M429 S&A Detent Spring.

Housing Components

The S&A mechanism is assembled into a flanged aluminum Housing (55450) with a small hole on top center. This hole is sealed with a clear mylar Disc (55475) which serves as a window for viewing the safe or armed condition of the S&A. Plastic Sleeve (55455) fits within the housing and supports the S&A. The housing is closed at the bottom with a threaded aluminum Closing Plug (55452). A plastic Closing Plug Insulator (55453) lies between the S&A and the Closing Plug. This, in conjunction with the Plastic Sleeve and mylar Disc maintain the S&A electrically isolated from the Housing. Lead Charge (11722781) is located in the center of the closing plug and is secured by Dust Seal (59001).

There are six No. 24 gage color coded wires which pass through a hole in the top edge of the Housing. As Figure 3 shows, one pair of wires (red and yellow) is for the auxiliary arming switch and both leads are isolated from the frame of the S&A device. A second pair of wires (black and white) is for the piston actuator safety lock. The black lead is connected to the frame of the S&A device and provides the ground return for the actuator. Since the case of the electric detonator is also grounded to the frame of the S&A device, this actuator circuit ground provides a backup path through the rotor pivots for the normal detonator ground (green). The third pair of wires (orange and green) connect to the switch contact blades for the electric detonator circuit.

4. Operation of the SEAGNAT Fuze S&A Device

The modified M429 fuze S&A device for the SEAGNAT fuze operates in the following manner. At launch, the piston actuator fires which unlocks the first of two safety locks on the rotor. Rocket acceleration drives the g-weight down, removing the second rotor lock. Under the influence of continued acceleration, the rotor rotates into line with the explosive train. When the rotor reaches the in-line position, the detonator contacts close, the auxiliary arming switch closes, and a detent driven by a separate leaf spring in the switch locks the rotor in the armed position.

5. Development Program

5.1 Design Requirements -

Arming acceleration non-arming

The S&A shall not arm when subjected to a sustained axial acceleration of 5 g.

The non-arm and arm requirements shall be met at any temperature between -40°F and $+160^{\circ}\text{F}$.

Arming time

With an applied axial acceleration of $8\text{ g} \pm 0.5\text{ g}$, the time from rotor release to rotor alignment (as determined by closure of the arming switch) shall be not less than 0.5 sec. or more than 1.2 sec., at any temperature between -40°F and 160°F .

Reset to safe position

The S&A shall reset to the fully safe position when the acceleration is removed before arming is completed at any temperature between -40°F and $+160^{\circ}\text{F}$.

Independent safety feature

The S&A design modification shall include provisions for using a IMT172 piston actuator to provide an independent lock on the S&A rotor. (The piston actuator will be initiated prior to application of acceleration).

Mounting hardware

The mounting hardware shall include provisions for:

- a. Proper in-line explosive train propagation from detonator to lead.
- b. Proper static detonator safety performance in accordance with MIL-STD-331, Test 115.
- c. Visual observation of position of rotor.
- d. Maximum practicable electromagnetic shielding.

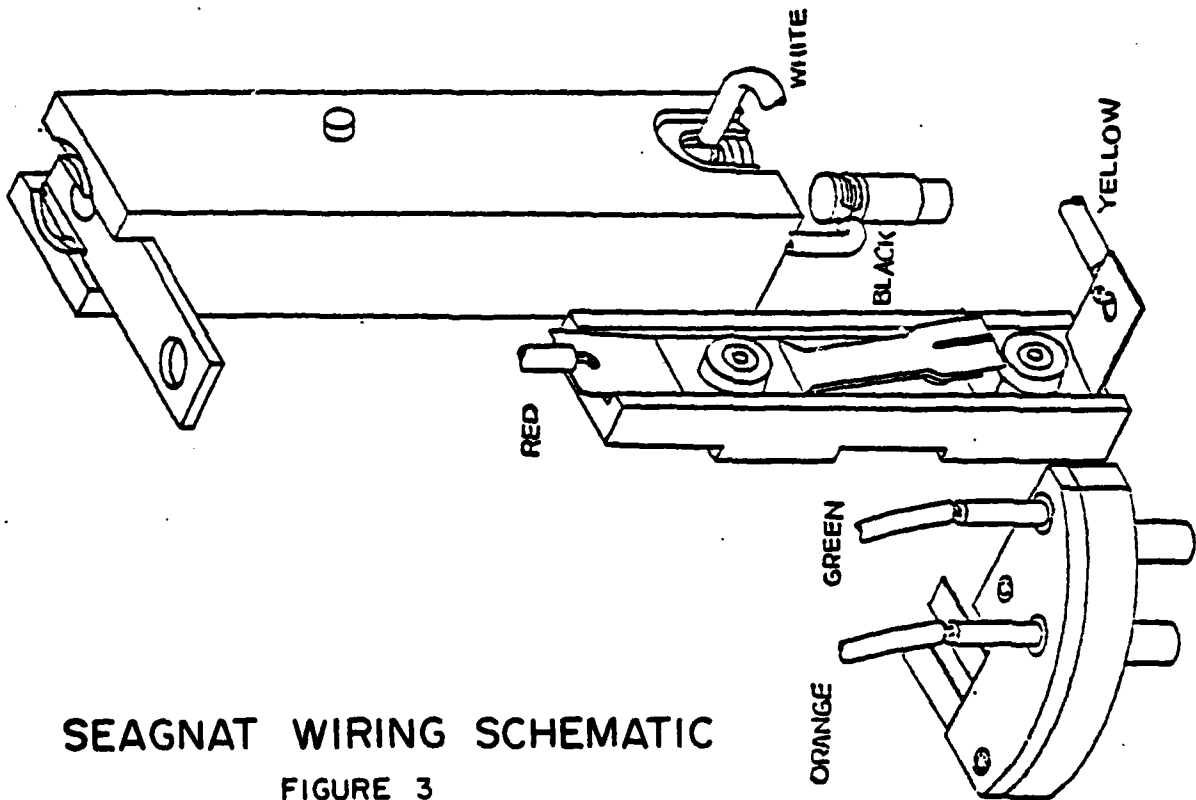
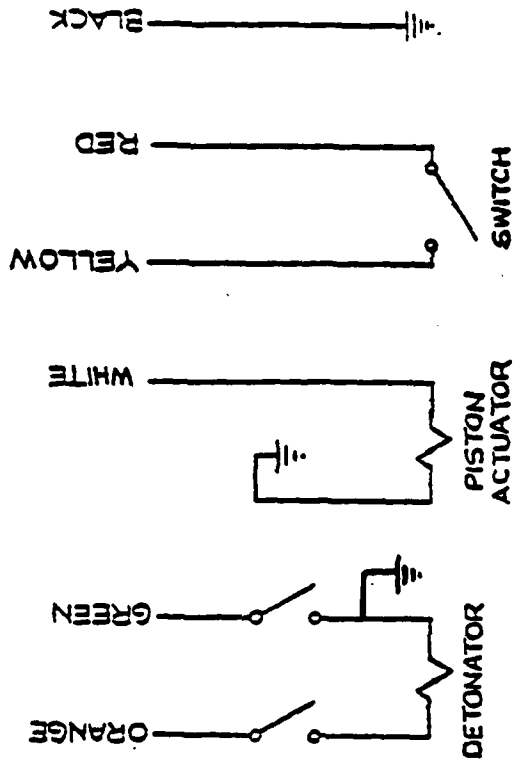

SEAGNAT WIRING SCHEMATIC

FIGURE 3

Auxiliary arming switch

Shortly after the contract began, the contract was modified to add an extra electrical switch, as follows:

The switch shall be a single pole, single throw type and shall be electrically isolated from the existing switch in the S&A device. It shall be designed to remain open during all rough handling environments experienced by the S&A device in the safe condition. It need not close at any specific point in the arming cycle but it must be closed when the S&A device is fully armed. Actuation of the switch shall not degrade reliability of arming of the S&A device. In the closed position with the S&A device armed, the switch must remain closed during vibration of + 15 g amplitude from 60 to 2000 Hz. (Ref. MIL-STD-810C, Method 514.2-V-R/AH, 10% test durations). The switch contacts shall be designed to carry 30 VDC at 10 amp for 10 milliseconds. Contact resistance shall not exceed 0.5 ohm and insulation resistance shall be capable of withstanding 500 VDC.

5.2 Design Requirements Satisfied -

Arming acceleration non-arming

The S&A does not arm when subjected to a sustained axial acceleration of 5 g

Each S&A is tested on the centrifuge at ambient temperature to ascertain that there is no g-weight movement at 5 g.

Arming time

The SEAGNAT S&A meets this requirement. (See Arming Time, table 1.)

Reset to safe position

All SEAGNAT S&A's do not meet this requirement in all attitudes. To reliably meet this requirement, with the device in a vertical orientation, either larger g-weights or g-weights made of a metal heavier than brass would be required in conjunction with stronger bias springs.

Independent Safety Feature

The SEAGNAT S&A meets this requirement.

Mounting hardware

The SEAGNAT S&A meets the requirements of 1.5 a, b and c. There were no tests performed at Hamilton Technology to confirm item d. "Maximum practicable electromagnetic shielding".

Auxiliary arming switch

The SEAGNAT S&A meets all requirements except that the insulation resistance of the wiring is rated at 250 VDC. Hamilton Technology was granted permission to use this wire by HDL engineering.

5.3 Development Work Performed

A kickoff meeting was held at Hamilton Technology on 27 January 1978. By the end of February 1978, the design layout was completed and some piece parts were released to the model shop.

For the initial design, a M429 fuze S&A device was modified as follows:

1. A brass block was secured to the cutout in the rotor.
2. The pallet assembly consisted of a single aluminum lamina with standard pallet pins.
3. Two teeth were removed from the annular gear.
4. A heavy copper-tungsten setback weight was used.

This unit was spun in the centrifuge. At 5 g the detonator contacts did not close nor did the rotor move to a fully armed, detented position. At 8 g the arming time was .623.

After considerable testing and a number of iterations, it was decided that the pallet assembly should be one where two aluminum laminas would be used so as to provide more stability and support for the pallet pins. Further the g-weight would be the same one as is used on the M429 fuze S&A device. This decision was influenced somewhat by the fact that the tooling to produce the copper tungsten g-weight blanks had been destroyed. The brass block which was added to the cutout in the rotor was increased to the maximum practical size that would fit within the insulated

sleeve and housing. A third tooth was removed from the annular gear. By mid June, g-weight springs of the finalized design were received.

An assembly and loading procedure was prepared to serve as a guideline for all units shipped. Revision D of this procedure is included in the report as appendix A.

5.3.1 Escapement

The pallet inertia was reduced to allow the rotor to arm faster. The first model assembled contained a single lamina aluminum escape lever with standard pallet pins. A single lamina did not provide enough support to maintain the pallet pins perpendicular to the lever and parallel to each other. Two-lamina pallet lever assemblies were tested but with the outside diameter reduced. The final design selected was one using two aluminum levers without their outside dimensions reduced. The time delay was reduced by removing the last two teeth from the annular gear on the rotor. Later in the program an additional tooth was removed making a total of three teeth removed from the original M429 fuze S&A annular gear.

Since the SEAGNAT fuze S&A device would be operating in a much lower g field than the M429 fuze S&A did, a small block of brass was added to the cutout in the rotor to provide increased torque to drive the escapement. The final size and shape appear to be the largest that could be attached to the rotor and still allow sufficient clearance to the insulating sleeve and housing.

The arming times at 8 and 12 g were determined for each S&A delivered. Table 1 summarizes the arming times for each lot shipped.

TABLE 1
ARMING TIME'S FOR EACH LOT OF S&A'S

Quantity Shipped	Date Shipped	At 8 g		At 12 g	
		\bar{X} (S)	σ (S)	\bar{X} (S)	σ (S)
5 Hycor 25 HDL	5-5-78	0.841	0.026	0.666	0.019
13	7-13-78	0.665	0.025	0.534	0.018
25	8-2-78	0.691	0.020	0.547	0.016
30	9-12-78	0.715	0.018	0.560	0.017
53	11-9-78	0.706	0.028	0.560	0.017
35	2-23-79	0.667	0.018	0.540	0.015
55	3-26-79	0.670	0.023	0.537	0.015
49	4-23-79	0.705	0.026	0.557	0.021
70	5-25-79	0.699	0.024	0.560	0.019
35	6-24-80	0.684	0.025	0.541	0.017
51	9-30-80	0.672	0.022	0.544	0.014
409	12-16-80	0.700	0.028	0.562	0.021

- 1) All units were tested at ambient temperature.
- 2) Acceleration is calculated using a measured distance of 11.015 in. from the center of rotation to the bottom of the g-weight when it is in the safe position.
- 3) The rotors of the above S&A's did not contain an electric detonator during the timing. Tests conducted at 12 g's on one S&A resulted in arming time of $\bar{X} = 0.674$ s and $\sigma = 0.006$ s without a detonator in the rotor. With a properly weighted inert detonator in the rotor the same S&A, the arming time was $\bar{X} = 0.653$ s and $\sigma = 0.006$ s.

The following arming time tests were conducted on 5 development models

Five S&A's were conditioned at +170°F for 6 hours; the resulting arming times were as follows.

$$8 \text{ g} - \bar{X} = 0.815 \text{ s} \quad \sigma = 0.035 \text{ s}$$

$$12 \text{ g} - \bar{X} = 0.652 \text{ s} \quad \sigma = 0.027 \text{ s}$$

Same five S&A's conditioned at -45°F for 6 hours; the resulting arming times were as follows.

$$8 \text{ g} - \bar{X} = 0.961 \text{ s} \quad \sigma = 0.053 \text{ s}$$

$$12 \text{ g} - \bar{X} = 0.713 \text{ s} \quad \sigma = 0.080 \text{ s}$$

Same five S&A's at ambient temperature had arming times as follows.

$$8 \text{ g} - \bar{X} = 0.823 \text{ s} \quad \sigma = 0.043 \text{ s}$$

$$12 \text{ g} - \bar{X} = 0.657 \text{ s} \quad \sigma = 0.024 \text{ s}$$

Note that these S&A's were not in housings; during the -45°F tests, some frost formed on the assembly.

5.3.2 G-Sensing Components

The first model assembled contained a setback weight made of copper tungsten. A number of centrifuge tests were conducted using this setback weight and various spring configurations. It was later determined that the original M429 setback weight would suffice.

5.3.3 Housing

The original housing was made up of two parts, the outer sleeve with flange and a top plate. This design was selected with the intent of obtaining tubing and machining the outer sleeve and flange without having to bore out a large quantity of metal from the center portion. However, attaching the top plate was more of a problem than anticipated. Further, the top plate occasionally would blow out during an out-of-line safety test.

Out-of-line safety tests conducted on the early units developed a crack approximately 0.05 in. wide and 0.37 in. long in the housing adjacent to the MK96 electronic detonator. The case wall thickness was increased and the housing was redesigned into a one piece housing. Repeating the out-of-line safety tests resulted in only a slight bulge in the housing with no cracks noted.

5.3.4 Auxiliary arming switch

The original auxiliary switch design is shown in Figure 4. It was actuated (closed) by the rotor detent dropping into a hole in the rotor when the rotor was in the armed position.

The switch was subjected to the following testing:

The switch must remain closed during vibration of +15 g amplitude from 60 to 2000 Hz (Ref. MIL-STD-810C Method 514.2-V-R/AH, 10% Test Duration). The testing was later extended to include 5 to 60 Hz (Fig. 514.2-5).

The switch was vibrated in each of three mutually perpendicular axes. In one position the detent (55741) was over the contact blade (55474).

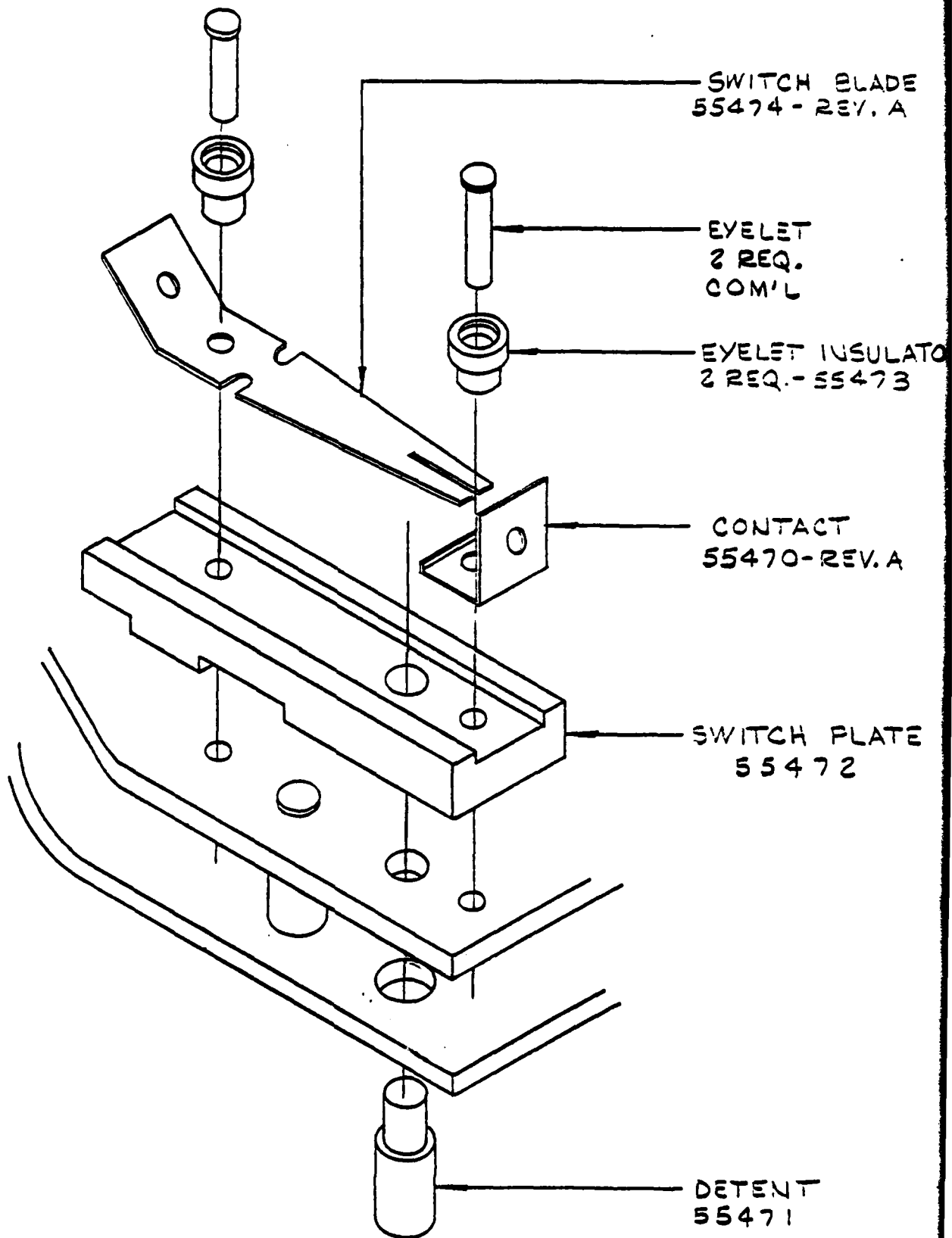

AUXILIARY ARMING SWITCH - ORIGINAL DESIGN

FIGURE 4

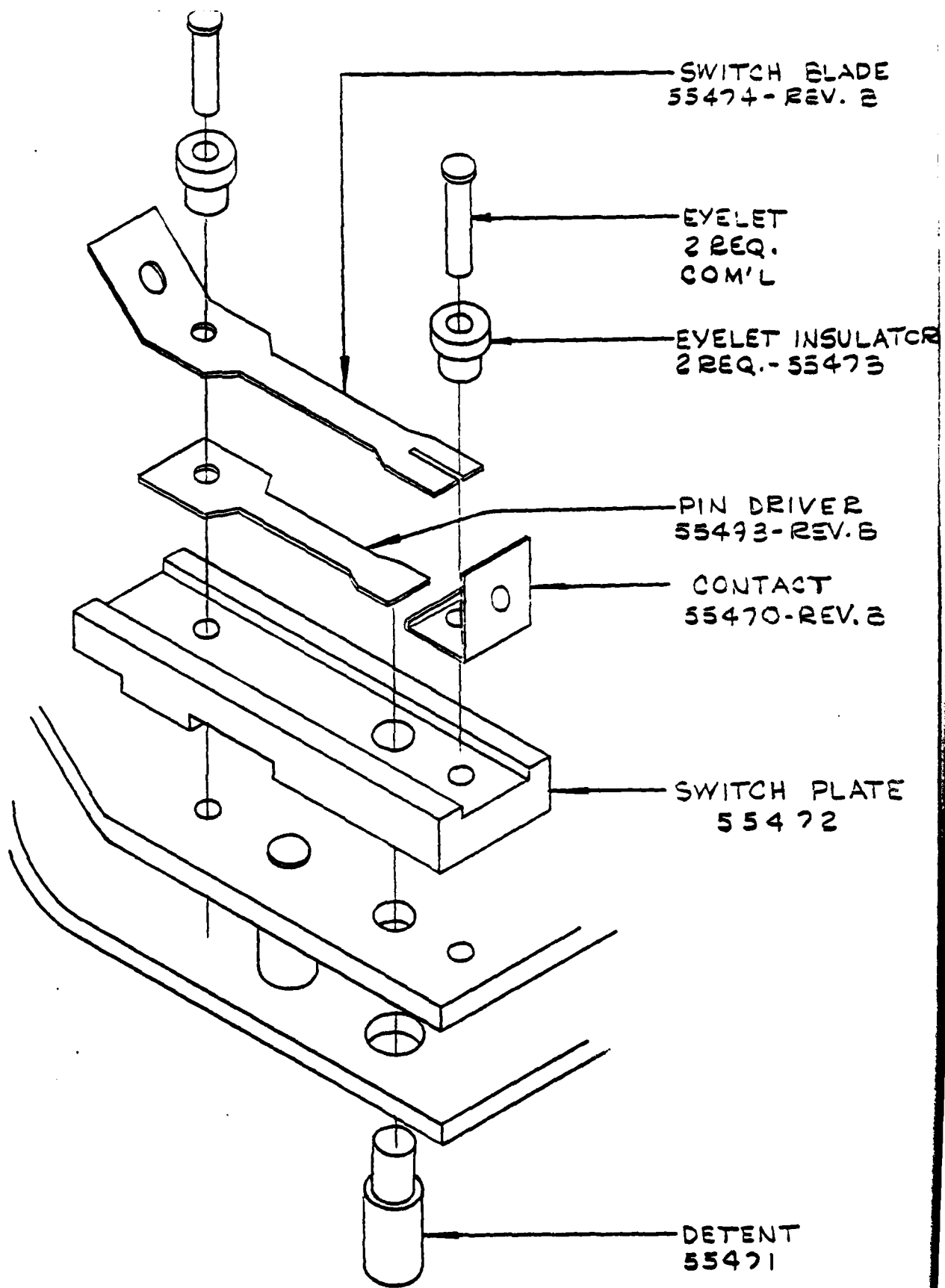

AUXILIARY ARMING SWITCH - FINAL DESIGN

FIGURE 5

The closed switch was connected to a brush recorder throughout the tests. Analysis of the first tape indicated higher resistance than desired. The switch was disassembled and the contact and switch blade were gold plated. The test was repeated and the tapes showed a substantially cleaner trace. The tests were then repeated with the switch connected to a chatter checker. The chatter checker is capable of indicating a contact break in excess of 10 microseconds.

In the test where the detent was positioned over the switch blade, chatter in excess of 10 microseconds was noted at 225 Hz. This test was repeated several times at reduced g levels until there was no contact chatter noted. No chatter occurred at 12g.

The unit was tested several times from 60 to 2000 and 2000 to 60 Hz at 12 g with no chatter indicated.

The prototype was also vibrated in three mutually perpendicular axis sweeping from 5 to 60 and 60 to 5 Hz at 12 g without chatter.

The prototype was placed in the centrifuge and accelerated so as to cause the detent to tend to open the switch. The rotor assembly was jammed so that the detent was free of the rotor. The unit was accelerated to 44 g with no loss of continuity noted.

The force required to open the switch was measured with a force gage. The force required to just break the circuit was 7.1 grams. The standard detent plunger on the M429 required 1/2 oz. of force to move the detent flush with the clock plate.

Problems were noted with distortion of switch blades during assembly. The method of staking the eyelets was changed from a hammer stake to a controlled force press. This resulted in uniform assemblies which eliminated the distortion of the contact blade and the insulated bushings.

Early in the development of the auxiliary arming switch, performance problems were noted with some units. As a result, all S&A's delivered on 11-9-78 were subjected to a centrifuge test which applied 100g of axial load to the detent while monitoring switch continuity. All switches remained closed at 100 g. A test fixture was made which allowed a 6 gram load to be applied to the detent while monitoring switch resistance for a maximum of 0.5 ohms. The test was to be performed on all units to be delivered.

HDL engineering developed an alternate design for the drogue switch (fig. 5). The advantage of this design is apparent in that a separate spring maintains pressure on the detent after the switch has closed. This prevents the detent from causing the contact blade to bounce during vibration. All S&A's delivered after 2-23-79 contained this switch design.

5.3.5 Piston Actuator Housing

The striker housing on the M429 fuze S&A was modified as shown on figure 1 to accept the 1MT172 piston actuator.

Approximately three quarters through the program, occasional high resistance was noted in the piston actuator circuit. X-raying the piston actuator housing assemblies showed that some of the problems resulted from improper installation of the spring washer (55461). There was also the possibility that corrosion might be responsible for some high resistances. To alleviate these problems all remaining piston actuator housings were chromate coated, all assemblies were x-rayed and defective assemblies removed, and a spring pin was installed through what would have been the release shaft bearing hole in the M429 S&A striker housing. The spring pin provided a second ground path for the piston actuator body. These changes were incorporated in the last lot of 409 S&A devices delivered on 12-16-80.

5.3.6 HDL Proposed Revisions

During December 1979, Hamilton Technology was notified of four changes proposed by HDL to be incorporated into the remaining units to be delivered. They were as follows:

1. Modify the housing to allow the wires to exit straight out of the top edge of the housing. Plug the existing hole in the side of the housing.
2. Modify the MK96 detonator switch assembly to provide a second alternative conductive path around the area where the positive post is clinched to the positive contact blade.

3. Adjust the perpendicularity of the piston actuator housing to prevent the possibility of g-weight jamming at the top of its travel.
4. Lubricate the g-weight assembly by dipping in a solution of 2 to 3 percent Vydax (microscopic teflon particles suspended in Freon). The S&A is to be dipped on its side with the g-weight in the lowermost position. Lubricant level to be approximately 0.3 in. to avoid contamination of the detonator switch.

Only S&A's shipped on 12/16/80 contained these changes.

6. Recommendations

The following list of recommendations is included so as to focus attention on those areas where improvements could be made.

The latest lubrication procedure (sect. 5.3.6) states that some parts of the S&A are to be lubricated with 5 percent Astro oil in Freon while other parts are lubricated with a 2.5 percent solution of Vydax in Freon. Hamilton Technology does not recommend using these two lubricants where there is a possibility of either one contaminating the other.

The design of the Switch Assembly 03052 should be revised to permit either a soldered or welded connection between Connector Posts 03057 and both Positive Contact 03056 and Ground Contact 03055.

The spring pin, used as an additional ground path for the piston actuator, should be replaced by a spring clip which would be attached to the piston actuator.

A method should be devised for sealing the hole in the housing through which the wires pass.

The rotor should be redesigned to eliminate the brass weight and screw.

The auxiliary arming switch could be redesigned as a molded subassembly.

A method of measuring auxiliary arming switch contact pressure should be devised along with the redesign noted above.

A method should be devised which would allow the SEAGNAT fuze S&A to be checked out after the device has been installed in its housing.

APPENDIX A
ASSEMBLY & LOADING PROCEDURE
FOR SEAGNAT S&A

55491 - ASSEMBLY & LOADING PROCEDURE
FOR SEAGNAT S & A (MODIFIED 429) PART #55480

NOTE: ** INDICATES INSPECTION POINT

(D) January 1981
(C) May 1980
(B) February 5, 1979
(A) November 17, 1978
Revisions

1.0 ROTOR ASSY. 55485 (less detonator & clip)

Assemble as shown on 55485.

- ** 1.1 Visually inspect terminal assembly 03407 to make certain it is firmly staked.
- (A) ** 1.2 Visually inspect ground contact pin. Adjust height as required to within $\pm .01$ of terminal pin. Check height of pins to dimension shown on 55485.
- (A) 1.3 Clean entire assembly (in Freon) and lubricate
- (C) Rotor Pivot using lubricant shown on 55490. (Do not dip entire Rotor Assy.). Lubricate lock roller with 20/1 solution of vydax and freon. Do not intermix lubricants.

2.0 ESCAPEMENT ASSEMBLY 55483

- ** 2.1 Assemble clock less switch as shown and check gear train for freeness by rotating the #2 gear pinion assembly 360° in both directions.
- (B) 2.2 Burnish I.D. of holes for Detent 55471 (both plates)
- 2.3 Clean and lubricate as shown on 55490.
- 2.4 Solder red and yellow wires to switch blade 55474 and contact 55470 respectively. See 55479, sheet 2 for lead dress. Clean as shown on 55489.
- (A) ** 2.5 Assemble switch per 55480. Check eyelets under clock plate for correct rollover of riveted end.
- (B) ** 2.6 Inspect Switch Assembly for plastic chips, dirt and cracked insulated bushings. Make certain that Detent 55471 is free. Clean or rework as required.
- (B) ** 2.7 Check resistance between yellow and red wires. Resistance to be 0.2 ohms max. after deducting the resistance of the lead wires.

3.0 PISTON ACTUATOR HOUSING ASSY. 55481

3.1 Solder white wire to terminal 55464 and clean as shown on 55489.

3.2 Insert terminal 55464 into insulator sleeve 55462 and insert insulator disc 55463.

CAUTION

The remainder of this assembly must be performed in the loading chamber.

Conductive shoes must be worn or disposable boots must be worn over street shoes and must be secured to the bare legs with rubber bands. Cotton clothing should be worn.

A grounded wrist strap must be worn and an all metal chair must be used.

The package of 1MT172 piston actuators must be covered with aluminum foil and must be stored in a loading chamber adjacent to the chamber where the operator is working.

These devices do not explode like a detonator, however, when the piston actuator is initiated, the piston is expelled with a force of 100 to 300 pounds. It is important to remember that in handling this device that the piston must not be pointed in the direction of the operator's hands or face more than is absolutely essential to the completion of the assembly.

Do not handle the piston actuator with bare hands. Always use a brass tweezers.

- (A) 3.3 Insert the piston actuator into the piston actuator housing 55467 so that the piston actuator's terminal will enter the terminal 55464. It may be necessary to use several pounds of force to fully seat the piston actuator. Press on the end of the plunger of the piston actuator.

- (D) 3.4 Insert spring washer 55461 into release plate assy. 55482, making certain that the spring is laying flat. See Sketch Below.
- 3.5 Enter the release plate assy. 55482 into the piston actuator housing and seat in the slot. (Refer to Dwg. 55481 to ensure proper positioning of the release plate).
- (B) ** 3.6 Place this assembly in a staking fixture and stake as specified on dwg. 55481. Sample inspect 1 piece in 50 for $50 \pm 20\%$ pushoff. Sample must not contain piston actuator or connector and insulator.
- 3.7 Apply a small drop of silastic RTV (2 places) per notes 2 and 3 of dwg. 55481 and allow to cure overnite.

(D)

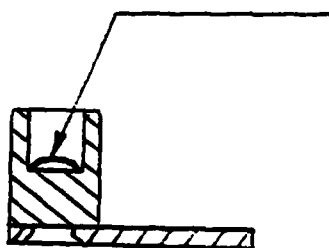

Spring Washer 55461
to be assembled in this
position

4.0 S & A FINAL ASSY. Dwg. 55479

- (D) 4.1 Lubricate hinge pin 03051 with lubricant 55490. Lubricate the set-back weight with a 2.5% solution of Vydax and Freon.
DO NOT INTERMIX LUBRICANTS.
- (a) 4.2 Install setback weight springs 55477 on an .092" dia. rod. Align rod with spring stud and slide spring onto spring stud until almost at solid height. Secure in this position with a small copper spring clip.
- 4.3 Insert detent 55471 into escapement assy.
- 4.4 Insert .124 dia. pivot of rotor assy. 55485 into escapement assembly 03027.
- 4.5 Position setback weight 62265 adjacent to the rotor and lower these three assemblies into the main frame assy. 55486.
- 4.6 Remove spring clips from setback weight springs and guide components into place.
- 4.7 Temporarily secure with screw 03060 into outer plate 55469 of escapement assy.
- 4.8 Temporarily insert hinge pin 03051 (finger tight) and check clock and rotor for freeness.
- 4.9 Press in hinge pin 03051 and shoulder pin 03050 and install screw 03060 (2) into clock and torque to 40 oz. in. Stake each screw head.
- (B) ** 4.10 Place rotor in armed position and check detent 55471 for presence of axial play.
- ** 4.11 As rotor moves into armed position, make certain there is deflection of both blades of switch 55456.

- (B) ** 4.12 With Rotor Assy. 55485 in the armed position, check resistance between the orange wire and (detonator) Terminal Contact 03045 in the Rotor. Max. resistance on Simpson Meter to be 0.5 ohms.
- (D) 4.13 Measure the resistance between the orange and black wires with the rotor in the armed position. The reading must show infinity.

5.0 TESTING PROCEDURE

All unloaded S & A's must be subjected to an acceleration of 5 g's, 8 g's and 12 g's. Acceleration is calculated using a measured distance from the center of rotation to the bottom of the g-weight when it is in the safe position. The distance of 11.015" produces the following RPM to which the centrifuge must be set:

5 g's = 126.4 RPM (\pm .2)

8 g's = 159.9 (RPM (\pm .2)

12 g's = 195.8 RPM (\pm .2)

The S & A is installed in the centrifuge fixture and the red, green and yellow wires from the S & A are connected to the red, green and yellow wires (connectors) on the fixture. (G-Wt. Flat Side Facing Up)

- ** 5.1 5 g Test - Start the centrifuge and adjust the speed to 126.4 RPM. Press and hold the g weight release button for 3 seconds. Observe that neither the red light nor the green light came on.
- (A) ** 5.2 8 g Test - Start the centrifuge and set the speed to 159.9 RPM. Press and hold the g-weight release button for 3 seconds. Observe the time delay (before releasing the button) and record the time. Make certain the green light is on. The time delay shall fall between 0.62 and 0.76 seconds (tentative).
- (A) ** 5.3 12 g Test - Remove the S & A and reset to safe by releasing the Detent 55471 from the rotor. Start the centrifuge and set the speed to 195.8 RPM. Press and hold the g-weight release button for 3 seconds. Observe the time delay (before releasing the button) and record the time. Make certain the green light is on. The time delay shall fall between 0.51 and 0.60 seconds (tentative). Remove the S & A and do not reset.

6.0 EXPLOSIVE LOADING PROCEDURE

CAUTION

CONDUCTIVE SHOES MUST BE WORN OR DISPOSABLE CONDUCTIVE BOOTS MUST BE WORN OVER STREET SHOES AND MUST BE SECURED TO THE BARE LEGS WITH RUBBER BANDS. COTTON CLOTHING SHOULD BE WORN.

A GROUNDED WRIST STRAP MUST BE WORN AND AN ALL METAL CHAIR MUST BE USED.

THE PACKAGE OF MK96 ELECTRIC DETONATORS MUST BE COVERED AT ALL TIMES WITH ALUMINUM FOIL AND THEY MUST BE STORED IN A LOADING CHAMBER ADJACENT TO THE CHAMBER WHERE THE OPERATOR IS WORKING.

DO NOT HANDLE EXPLOSIVES WITH BARE HANDS, USE A BRASS TWEEZERS.

(A) NO RADIOS OR FLUORESCENT LIGHTS MAY BE USED WITHIN 50 FT. OF THE LOADING AREA.

(A) NOTE - BE CAREFUL NOT TO BEND, DISPLACE OR CONTAMINATE ANY SWITCH CONTACTS WHILE HANDLING THE UNIT.

1. REMOVE DUMMY PISTON ACTUATOR HOUSING.
2. MAKE CERTAIN ROTOR IS IN ARMED POSITION.
3. VISUALLY CHECK TWO CONTACT PINS ON ROTOR FOR UNIFORMITY OF HEIGHT.
4. CHECK FOR LOOSE OR BROKEN WIRES AT TERMINALS.
5. INSERT S & A INTO LOADING FIXTURE (CHECK THAT WIRES ARE NOT PINCHED).
6. MAKE CERTAIN THAT RESISTANCE METER SHORTING SWITCH (IN ALUMINUM BOX) IS IN SHORTING POSITION, I.E. THE TOGGLE SWITCH IS ON EITHER SIDE OF THE CENTER POSITION.
7. INSERT, ONE EACH, ORANGE AND GREEN LEADS INTO EACH OF THE CLIPS ON THE (BROWN) CLIP BLOCK.
8. ENGAGE COVER OF LOADING FIXTURE AND TURN COVER FULLY CLOCKWISE.
9. ROTATE FIXTURE UNTIL OPENING (FOR WIRE LEADS) IS FACING THE REAR OF THE LOADING CHAMBER.

NOTE: ** INDICATES INSPECTION POINT

CAUTION

DURING HANDLING OF THE DETONATOR AND S & A FROM THIS POINT ON UNTIL THE UNIT IS CASED, DO NOT SLIDE YOUR SHOES OR BODY ON THE FLOOR OR CHAIR. MAKE CERTAIN YOUR BARE ARMS ARE TOUCHING THE METAL LOADING CHAMBER. ALWAYS KEEP EXPLOSIVE POINTING AWAY FROM FINGERS.

10. LIFT THE SHIELDED COVER FROM THE PACKAGE OF MK96 DETONATORS AND WITH BRASS TWEEZERS REMOVE ONE DETONATOR AND REPLACE THE COVER.
11. PLACE DETONATOR, BUTTON DOWN, IN SMALL ROUND HOLDING FIXTURE.
12. PLACE TINNERMAN (COPPER) CLIP IN CLIP INSTALLATION TOOL MAKING CERTAIN THE 4 POINTED TABS ENTER LAST AND LOCATE IN THE CLEARANCE SLOTS IN THE TOOL.
13. PRESS CLIP LOADING TOOL FIRMLY OVER DETONATOR UNTIL SEATED.
14. PRESS KNOB OF CLIP LOADING TOOL WHILE HOLDING THE BODY OF THE CLIP LOADING TOOL - THIS WILL EJECT THE DETONATOR AND CLIP INTO THE SMALL ROUND HOLDING FIXTURE.
15. PLACE SMALL ROUND HOLDING FIXTURE ON TOP OF LARGE S & A LOADING FIXTURE AND ALIGN WITH THE PUNCH ASSY.
16. BRING DOWN PRESS PUNCH CAREFULLY MAKING CERTAIN THE DETONATOR AND CLIP ENTER THE PUNCH RECESS.
17. REMOVE SMALL ROUND DETONATOR HOLDING FIXTURE.
18. CAREFULLY (GUIDE AS REQUIRED) PRESS DETONATOR INTO ROTOR ASSY. UNTIL IT BOTTOMS.
- (A) 19. ALLOW PRESS HANDLE TO RESTORE AND INSERT BRASS PUNCH INTO PRESS PUNCH AND FIRMLY SEAT THE DETONATOR. REPEAT 3 TIMES MOVING BRASS PUNCH APPROXIMATELY 120° EACH TIME. DO NOT USE EXCESSIVE FORCE.
20. REMOVE LOADING FIXTURE COVER BY ROTATING COUNTERCLOCKWISE AND LIFTING OFF.
- (A) ** 21. OBSERVE THAT THE DETONATOR AND THE TINNERMAN CLIP IS FLUSH OR BELOW THE ROTOR BODY.
22. LIFT ASSEMBLY FROM LOADING FIXTURE.
23. TURN ON METER TO "VOLTAGE LIMITED" POSITION. ALLOW TO WARM UP 30 SECONDS.

24. REMOVE BOTH HANDS FROM THE LOADING CAGE AND PLACE SHORTING SWITCH TOGGLE LEVER (ON ALUMINUM BOX) IN CENTER POSITION AND LIFT METER LEVER TO "OPERATE" POSITION.
 - ** 25. READING MUST FALL WITHIN THE 2 AND 5 POSITION ON THE (UPPER) 0-10 SCALE. SET METER ON 10 OHM SCALE.
 26. RETURN METER LEVER TO CENTER POSITION.
 27. RETURN SHORTING SWITCH LEVER (ALUM. BOX) TO EITHER SIDE.
 28. REMOVE ORANGE AND GREEN WIRES FROM CLIP AND WRAP BARE ENDS SECURELY TOGETHER.
 - (B) ** 29. INSERT, ONE EACH, YELLOW AND RED WIRE LEADS INTO EACH OF THE CLIPS ON THE (BROWN) CLIP BLOCK. PLACE SHORTING SWITCH TOGGLE LEVER (ON ALUMINUM BOX) IN CENTER POSITION AND LIFT METER LEVER TO "OPERATE" POSITION. SET METER ON 1 OHM SCALE.
- THE READING MUST FALL BELOW 0.2 OHMS AFTER DEDUCTING THE RESISTANCE OF THE LEAD WIRES.
- RETURN METER LEVER TO CENTER POSITION AND RETURN SHORTING SWITCH LEVER (ALUMINUM BOX) TO EITHER SIDE.
30. LAY S & A WITH EXPLOSIVE POINTING TO REAR OF LOADING CHAMBER AND WITH ROTOR DETENT FACING UP.
 31. EXTRACT DETENT FROM ROTOR WITH TWEEZERS - DO NOT DAMAGE SWITCH ASSEMBLY.
 32. WHEN ROTOR IS FULLY RESTORED, ROLL S & A OVER SO THAT PISTON ACTUATOR HOUSING ASSY. MAY BE INSTALLED.

CAUTION

KEEP FINGERS AND TWEEZERS AWAY FROM TERMINALS ON ROTOR ASSEMBLY.

- (B) ** 33. INSTALL PISTON ACTUATOR HOUSING WITH (2) SCREWS & TORQUE TO 40 IN. OZ. (2.5 IN. LB.). DO NOT BEND BRACKET SUPPORTING THE PISTON ACTUATOR HOUSING. POSITION S & A W/PISTON ACTUATOR HOUSING UPRIGHT.
- (C)
- (B) ** 34. SET METER ON 10 OHMS SCALE. INSERT, ONE EACH, BLACK AND WHITE WIRE LEADS INTO EACH OF THE CLIPS ON THE (BROWN) CLIP BLOCK. PLACE SHORTING SWITCH TOGGLE LEVER (ON ALUMINUM BOX) IN CENTER POSITION AND LIFT METER LEVER TO "OPERATE" POSITION. READING MUST FALL WITHIN THE 4 & 9.5 POSITION ON THE (UPPER) 0-10 SCALE. RETURN METER LEVER TO CENTER POSITION AND RETURN SHORTING SWITCH LEVER (ALUMINUM BOX) TO EITHER SIDE. TWIST BARE ENDS OF BLACK AND WHITE WIRES TOGETHER.
35. CRIMP SCREWS, (33 ABOVE) 2 PLACES.

36. INSPECT FOR POSITIVE LOCKING OF ROTOR ASSY. WITH RELEASE PLATE.
- (A) ** 37. CHECK FOR JAMMING OF G-WEIGHT ON ROTOR ROLLER (ROTOR ASSY. SHOULD
(C) HAVE SLIGHT FREEDOM OF MOVEMENT). ADJUST PERPENDICULARITY OF PISTON ACTUATOR HOUSING A/R.
38. VISUAL INSPECT FOR WIRE DAMAGE, ETC.
39. FORM WIRES CAREFULLY SO THAT THEY WILL ENTER THE INSULATED SLEEVE. YELLOW WIRE ON TOP OF CLOCK PLATE BESIDE FRAME AND BLACK/WHITE WIRES BESIDE CLOCK ALONG PISTON ACTUATOR HOUSING.
40. INSERT BLACK/WHITE AND YELLOW WIRES THRU SMALL HOLE AND ORANGE/GREEN AND RED WIRES THRU LARGE OPENING OF THE INSULATED SLEEVE.
41. FORM WIRES CAREFULLY TO FOLLOW CUT OUTS IN THE INSULATOR HOUSING. GREEN/ORANGE WIRES FORM RADIUS TO RIGHT AND FORM SMALL CCW LOOP IN RED WIRE AND LAY TO RIGHT ABOVE GREEN/ORANGE WIRES.
42. MAKE CERTAIN NO WIRES CROSS EACH OTHER.
INSTALL WIRE HOLDING RING OVER ALL WIRES.
43. DO NOT FORCE HOUSING OVER WIRES - BACK OFF AND RECHECK WIRE ROUTING.
44. SEAT S & A ASSY. AFTER LOCATING ON PIN IN HOUSING.
45. INSERT CLOSING PLUG INSULATOR.
- (A) ** 46. INSERT CLOSING PLUG. SNUG TIGHT WITH TWEEZERS. CHECK THAT CLOSING PLUG IS FLUSH OR BELOW.
47. INSERT LEAD CHARGE AND SECURE WITH DUST SEAL.
- ** 48. MAKE CERTAIN THAT ROTOR STOP PIN (MS51923-129) IS VISIBLE THROUGH WINDOW IN TOP OF HOUSING ASSY. 55478.

gb

cc: R. M. Jackson
Y. Kastner

DISTRIBUTION LIST

Defense Technical Information Center (Attn: DTIC-DDA)	2 copies
Editorial Committee (Chairman)	
Branch 81300	1 copy
Branch 91400	1 copy
Harry Diamond Laboratories 2800 Powder Mill Rd. Adelphi, MD 20783 (DRXDO-DAB)	25 copies
Harry Diamond Laboratories 2800 Powder Mill Rd. Adelphi, MD 20783 (Attn: Library)	3 copies