

NBDL - 80R005

30

LEVEL II

SC

SOME USEFUL FILTER FORMS

Gilbert C. Willems

AD A100452



June 1980

DTIC
ELECTE
JUN 22 1981
S D
B

NAVAL BIODYNAMICS LABORATORY
New Orleans, Louisiana

Approved for public release. Distribution unlimited.

81 6

22 073

DTIC FILE COPY

REPORT DOCUMENTATION PAGE		READ INSTRUCTIONS BEFORE COMPLETING FORM
1. REPORT NUMBER NBDL-80 R005	2. GOVT ACCESSION NO. AD-A100 452	3. RECIPIENT'S CATALOG NUMBER
4. TITLE (and Subtitle) SOME USEFUL FILTER FORMS	5. TYPE OF REPORT & PERIOD COVERED Research Report	
	6. PERFORMING ORG. REPORT NUMBER NBDL 80 R005	
7. AUTHOR(s) GILBERT C. WILLEMS	8. CONTRACT OR GRANT NUMBER(s) /	
9. PERFORMING ORGANIZATION NAME AND ADDRESS NAVAL BIODYNAMICS LABORATORY BOX 29407 NEW ORLEANS, LA 70189	10. PROGRAM ELEMENT, PROJECT, TASK AREA & WORK UNIT NUMBERS 63706N M0097PN,001,5001	
11. CONTROLLING OFFICE NAME AND ADDRESS NAVAL MEDICAL RESEARCH & DEVELOPMENT COMMAND BETHESDA, MD 20014	12. REPORT DATE June 1980	
	13. NUMBER OF PAGES 48	
14. MONITORING AGENCY NAME & ADDRESS (if different from Controlling Office)	15. SECURITY CLASS. (of this report) Unclassified	
	15a. DECLASSIFICATION/DOWNGRADING SCHEDULE	
16. DISTRIBUTION STATEMENT (of this Report) APPROVED FOR PUBLIC RELEASE, DISTRIBUTION UNLIMITED		
17. DISTRIBUTION STATEMENT (of the abstract entered in Block 20, if different from Report)		
18. SUPPLEMENTARY NOTES		
19. KEY WORDS (Continue on reverse side if necessary and identify by block number) Electronic Filters, Signal Conditioning, Low Pass Filters, High Pass Filters, Bandpass Filters, Notch Filters, Noise Rejection, Digital Filters		
20. ABSTRACT (Continue on reverse side if necessary and identify by block number) A compilation of second order filters of the most common types used in signal conditioning is presented herein. All are derived from the minimum phase second order transfer function, and both analog and digital implementations are considered. The illustrations for each filter mechanization contain all essential de- sign information; in this manner they can be used as a design aid independently of the text.		

DD FORM 1473

1 JAN 73

EDITION OF 1 NOV 65 IS OBSOLETE
S/N 0102-014-6601

UNCLASSIFIED

SECURITY CLASSIFICATION OF THIS PAGE (When Data Entered)

NBDL -80R005

SOME USEFUL FILTER FORMS

Gilbert C. Willems

June 1980

Bureau of Medicine and Surgery
Work Unit M0097PN,001,5001

Approved by

Released by

Channing L. Ewing, M. D.
Scientific Director

Captain J. E. Wenger MC USN
Commanding Officer

Naval Biodynamics Laboratory
Box 29407
New Orleans, LA 70189

Opinions or conclusions contained in this report are those of the author(s) and do not necessarily reflect the views or the endorsement of the Department of the Navy.

Approved for public release; distribution unlimited.

SUMMARY PAGE

THE PROBLEM

Almost all data acquired via transducers during impact experiments must be conditioned via some sort of filter in order to optimize signal-to-noise ratio and avoid aliasing of noise during digitization procedures. To this end, rapid design techniques were developed which meet nearly all filtering requirements of the experimental impact programs of the Naval Biodynamics Laboratory.

FINDINGS

This study documents the evolution of a variety of digital and analog filters of all types developed over several years and presents them in a "design manual format." It has been found that included designs are adequate to meet almost all filtering needs for data acquired during biodynamic impact experiments.

RECOMMENDATIONS

The filter designs included herein are all laboratory proven and can be recommended to all users with similar needs.

ACKNOWLEDGEMENT

The author is indebted to Mrs. G. Bourgeois for an excellent job of assembling and typing the manuscript.

Trade names of materials or products of commercial or nongovernment organizations are cited only where essential to precision in describing research procedures or evaluation of results. Their use does not constitute official endorsement or approval of the use of such commercial hardware or software.

Accession For	
NTIS GRA&I	<input checked="" type="checkbox"/>
DTIC TAB	<input type="checkbox"/>
Unannounced	<input type="checkbox"/>
Justification	
By _____	
Distribution/	
Availability Codes	
Dist	Avail and/or Special
A	

SOME USEFUL FILTER FORMS

INTRODUCTION

Filtering is an integral part of almost all data acquisition and/or signal conditioning functions. The most commonly used filters can be categorized into one of the following general types:

1. Low Pass - Removes frequencies above some desired cutoff point.
2. High Pass - Removes frequencies below a certain desired point; a common special case of this type is the "washout" filter which usually has a very low cutoff frequency, and is primarily used to remove d.c. bias from data.
3. Bandpass - A combination of the above two types, it bounds the signal at both ends of the spectrum.
4. Notch - A very narrow band filter, generally designed to remove a single unwanted frequency from the signal.
5. Inverse filter - Occasionally data is acquired that was "overfiltered" for some reason, either intentionally or due to bandwidth limitation of the particular sensor used. Provided the filtering was not too severe and the filtering transfer function is known, the data can be recovered by means of an inverse filter; such a device cancels the effect of the original filter and moves the cutoff up in the frequency scale.

There are vast numbers of implementations and filtering philosophies available to the designer; one can easily get bogged down searching the voluminous literature for the "optimum" filter for a process and lose sight of the fact that the designer's job is to produce an adequate implementation in a timely fashion. The purpose of this report is to document and provide simple design information on a set of filters which have been found to satisfy most requirements. Both analog and digital filters are discussed, and all are derived from the same basic second order transfer function. This was selected as the root function, due to the fact that generally if a signal needs filtering at all, it probably needs at least a second order (40 db/decade slope) filter. Higher (even) order implementations are possible by simply cascading filters, or in the digital case, recirculating the data through the same algorithm.

ANALOG FILTERS

All analog filters considered herein are active filters utilizing inverting operational amplifiers. The latter are justifiable in that current technology produces high quality devices at low cost and high density of as many as four amplifiers per 14-pin DIP package. The advantages of using this active technique are:

1. No insertion loss
2. Realization of complex - pole 2nd order filters without inductive components

3. Design flexibility

4. Inherent stability of negative feedback circuitry

The design of such filters make use of the fact that the transfer function of an inverting operational amplifier is given simply by the ratio of the feedback to the input impedances, and that the summing junction current is negligible, i.e. this junction can be considered a virtual ground. Most analog filters considered herein are developed from a very useful configuration, the five impedance network shown in figure 1; if one uses Kirchhoff's current law and writes nodal equations at points 1 and 2 respectively, one obtains:

$$\frac{e_1}{Z_1} - \frac{e_i}{Z_1} + \frac{e_1}{Z_2} + \frac{e_1}{Z_3} + \frac{e_1}{Z_4} - \frac{e_o}{Z_4} = 0 \quad (1)$$

$$\frac{e_1}{Z_3} + \frac{e_o}{Z_5} = 0 \quad (2)$$

Solving the equation (2) for e_1 and substituting into the (1) yields, after rearranging:

$$\frac{e_o}{e_i} = - \frac{1}{Z_1} \left[\frac{Z_3}{Z_5} \left(\frac{1}{Z_1} + \frac{1}{Z_2} + \frac{1}{Z_3} + \frac{1}{Z_4} \right) - \frac{1}{Z_4} \right]^{-1} \quad (3)$$

This equation is valid for any realizable impedance Z , and is the basis for most filters to be developed in subsequent sections. Many other mechanizations are possible, but the ones derived herein have been found very useful and simple to implement.

LOW PASS FILTERS

The five impedances of figure 1 can be defined as follows:

$$Z_1 = Z_3 = Z_4 = R$$

$$Z_2 = C_1$$

$$Z_5 = C_2$$

This yields the circuit of figure 2; insertion into equation (3) and simplification yields:
 (Note: Throughout this discussion the arguments are omitted from the equations to simplify them.)

$$\frac{e_o}{e_i} = \frac{-1}{1 + 3RC_2 S + R^2 C_1 C_2 S^2} \quad (4)$$

where S is the Laplace operator. This is recognizable as the standard minimum phase 2nd order transfer function of the form:

$$\frac{e_o}{e_i} = \frac{-1}{1 + \frac{2\zeta}{\omega_n} S + \frac{S^2}{\omega_n^2}} \quad (5)$$

where ω_n = natural (break) frequency in radians/sec

ζ = damping ratio and is a measure of maximum overshoot at ω_n . By matching terms in these equations, the following is obtained:

$$\omega_n = \frac{1}{R} \sqrt{1/C_2 C_1} \quad (6)$$

$$\zeta = 1.5 \sqrt{C_2/C_1} \quad (7)$$

Low pass filters are usually specified by the break frequency and attenuation (in decibels) at that frequency. The latter is related to the damping ratio by the function

$$\text{Att. (db)} = 20 \log \frac{1}{2\zeta} \quad (8)$$

obtainable by computing the magnitude of the normalized form of equation (5) at $\omega = \omega_n$.

Another parameter of interest is the phase shift within the passband of the filtered signal. For the transfer function (5), the phase shift (Φ) is given by:

$$\Phi \text{ (radians)} = \tan^{-1} \frac{2\zeta \omega \omega_n}{\omega_n^2 - \omega^2} \quad (9)$$

where ω is the driving frequency. If we redefine this as $K\omega_n$, where K is any positive number, equation (9) becomes:

$$\Phi = \tan^{-1} \frac{2K\zeta}{1-K^2} \quad (10)$$

For typical filter damping ratios ($\zeta = .6$ to $.8$) and the fractions of the passband below approximately 20 - 30% ($K \leq .2$ or $.3$) equation 10 can be approximated by:

$$\Phi = \frac{2K\zeta}{1-K^2} \quad (11)$$

since for small angle $\tan \Phi = \Phi$. Expression (11) is relevant because it implies that for a significant portion of the passband, the phase shift varies linearly with frequency, thus the phase distortion introduced in this region consists merely of a pure time delay. The delay is defined by:

$$T_d \text{ (seconds)} = \frac{\Phi}{\omega} \quad (12)$$

introducing equation (11) for Φ and again replacing ω with $K\omega_n$, equation (12) becomes:

$$T_d = \frac{2\zeta}{\omega_n} \left(\frac{1}{1-K^2} \right) \quad (13)$$

It is obvious that as stated, for small K , T_d is constant, since $1 - K_n^2 \approx 1$ and:

$$T_d \approx \frac{2\zeta}{\omega_n} \quad (14)$$

Equations (6), (7), and (8) can now be used to develop an extremely simple "pencil and paper" design procedure. Rewriting (6) and (7) in terms of the circuit components yields:

$$R = \frac{1}{1.5 C_2} \left(\frac{\zeta}{\omega_n} \right) \quad (15)$$

$$C_1 = \frac{2.25}{\zeta^2} (C_2) \quad (16)$$

Generally, input design parameters are break frequency and attenuation at that frequency; given the latter, ζ is computed from equation (8). Most commonly used values are:

Att. at break	ζ
- 1 db	.56
- 3 db	.707
- 6 db	1

In summary, a typical stepwise design would be:

Given ω_n (in rad/sec)

- Select ζ
- Select C_2
- Compute R using equation (15)
- Compute C_1 using equation (16)

If the cutoff frequency is specified in hertz (f) rather than radians/sec, one replaces ω_n with $2\pi f$ in computing R. If phase shift and/or time delay are of interest, they can also be computed using the given equations. It should be noted that the damping ratio is a function of C_1 and C_2 only, thus the cutoff frequency can be changed via R without altering other filter parameters.

HIGH PASS FILTER

The five impedances of figure 1 can be defined as follows:

$$Z_1 = Z_3 = C_1$$

$$Z_2 = R_1$$

$$Z_4 = \infty \text{ (open circuit)}$$

$$Z_5 = \frac{R_2}{R_2 C_2 S + 1} \text{ (parallel R C network)}$$

This yields the configuration of figure 3, and insertion into equation (3) results in:

$$\frac{e_o}{e_{in}} = \frac{-R_1 R_2 C_1^2 S^2}{2 R_1 R_2 C_1 C_2 S^2 + (2 R_1 C_1 + R_2 C_2) S + 1} \quad (17)$$

which is a factorable function resulting in a pair of real poles:

$$\frac{e_o}{e_{i n}} = \frac{-R_1 R_2 C_1^2 S^2}{(1 + 2 R_1 C_1 S) (1 + R_2 C_2 S)} \quad (18)$$

The numerator term represents pure double differentiation, thus attenuation at zero frequency is infinite. The gain increases at a slope of + 40 db/decade until the two poles take effect. These normally would be equal in order to compensate for the numerator dynamics; the first constraint becoming:

$$2 R_1 C_1 = R_2 C_2 = \frac{1}{\omega_n} \quad (19)$$

where ω_n is again the break frequency in rad/sec. An additional constraint results from the determination of the gain within the circuit passband. This is normally determined by taking the limit of equation (18) as S approaches infinity, but in this case this results in an indeterminate form. However, applying L'Hospital's rule twice gives the desired parameter:

$$\text{Passband Gain} = G_p = \frac{C_1}{2 C_2} \quad (20)$$

combining (19) and (20) yields another equation for G_p in terms of the resistors, and both of these expressions must hold:

$$G_p = \frac{R_2}{4 R_1} \quad (21)$$

A design procedure can now be summarized as before:

Given ω_n (in rad/sec)

- a. select desired G_p
- b. select one component (usually C_1 or C_2)
- c. compute other C using equation (20)
- d. compute R_1 and R_2 from equation (19)
- e. equation (21) can be used to verify computation

This circuit consists of two real poles, hence the attenuation at the break will be -6 db from the passband gain. If lesser values are required, the following procedure can be used: In computing circuit components R_1 and R_2 , replace ω_n by ω'_n the latter given by

Desired attenuation	ω'_n
- 1 db	$1/3\omega_n$
-2 db	$1/2\omega_n$
-3 db	$2/3\omega_n$

The denominator of equation (17) is identical to a low pass filter, hence its phase lag is obtainable from equation (9) or (10). To this one must add the numerator contribution which is a constant 180° of lead, since the numerator is a pure double differentiator. Thus the total phase shift for the high pass filter is

$$\Phi_{HP} = 180^\circ - \Phi_{LP} \quad (22)$$

where Φ_{LP} is given by (9) and (10) as stated, with $\zeta = 1$ (real poles) and ω_n given by equation (19).

NOTCH FILTER

A useful variant of the five impedance network is obtained by defining the components as follows:

$$Z_1 = \frac{1}{C_1 S} ; Z_2 = \frac{1}{C_2 S}$$

$$Z_3 = Z_4 = R$$

$$Z_5 = \frac{1}{C_3 S}$$

this yields the network of figure 4; manipulations similar to those previously made yield the transfer function:

$$\frac{e_2}{e_1} = \frac{R C_1 S}{1 + 2RC_3 S + R^2 C_3 (C_1 + C_2) S^2} \quad (23)$$

this, as it stands is of limited usefulness; by adding another operational amplifier to the circuit and summing the input to e_2 , one develops the expression:

$$\frac{e_o}{e_{in}} = - 1 + \frac{e_2}{e_{in}} \quad (24)$$

which in terms of equation (23) becomes

$$\frac{e_o}{e_{in}} = - \frac{1 + (2RC_3 - RC_1)S + R^2 C_3 (C_1 + C_2) S^2}{1 + 2RC_3 S + R^2 C_3 (C_1 + C_2) S^2} \quad (25)$$

This equation which yields the circuit of figure 5 is obviously of the form

$$\frac{e_o}{e_{in}} = - \frac{1 + \frac{2\zeta_n}{\omega_n} S + \frac{S^2}{\omega_n^2}}{1 + \frac{2\zeta_d}{\omega_n} S + \frac{S^2}{\omega_n^2}} \quad (26)$$

where $\zeta_n < \zeta_d$ as required for a notch filter. One might as well specify ζ_n to be zero, which would yield infinite attenuation at ω_n . This is not realizable in practice, due to component imperfection, but attenuation of -40 db is readily achievable with this specification. This value of ζ_n yields the requirement

$$2RC_3 - RC_1 = 0 \quad (27)$$

Matching the coefficients of equations (25) and (26), one also obtains

$$\omega_n = \frac{1}{R} \sqrt{\frac{1}{C_1 (C_1 + C_2)}} \quad (28)$$

and

$$\omega_n = \frac{2\zeta_d}{2RC_3} \quad (29)$$

The above three equations can be rearranged to yield the required component specifications

$$\left. \begin{aligned} C_3 &= C_1 / 2 \\ C_2 &= \frac{1 - 2\zeta_d^2}{2\zeta_d^2} C \\ R &= \frac{1}{\omega_n \zeta_d (C_1 + C_2)} \end{aligned} \right\} \quad (30)$$

A positive value for C_2 requires that $\zeta_d < .707$, an acceptable restriction for a notch filter; we now have sufficient data to establish a design procedure:

Given ω_n (rad/sec) = notch frequency

- a. Select ζ_d (usually (approx.) 0.6)
- b. Select one component, say C_1
- c. Remaining components are computed using equation (30)

Equations (28) and (29) can also be combined to yield an expression for ζ_d

$$\zeta_d = C_3 \sqrt{\frac{1}{C_1(C_1 + C_2)}} \quad (31)$$

which shows that the damping ratio is independent of R ; thus R alone need be varied to change the notch frequency of the circuit. If one modifies the circuit of figure 5 to that of figure 6, the notch frequency can be tuned over a given range via the ganged potentiometer, without affecting any other filter characteristic.

The denominator phase shift can again be obtained from equation (9). The numerator contribution consists of a sudden change from 0° to $+180^\circ$ at the notch frequency. While this is not self-evident from equation (9) for $\zeta_n = 0$, one can make ζ_n arbitrarily small but finite, and see that the above holds.

BANDPASS FILTERS

No special circuitry is required to mechanize this configuration. Once the low and high cutoff frequencies are defined, such a filter can be realized by cascading a high and a low pass filter.

INVERSE FILTER

Inverse filtering or "cancellation compensation" is the least common "on-line" analog technique since its function is to compensate for an undesirable characteristic of some signal path and presumably a well designed system would not have such problems. However, there are occasional uses for such a device, for example if a sensor of insufficient bandwidth is used due to its being the only one available. The required transfer function is similar in form to that of a notch filter except that unrestricted freedom to choose both numerator and denominator parameters are needed. Such a network cannot be mechanized via the five impedance network. One convenient configuration can be obtained via the "bridged-T" network shown in figure 7. The transfer impedance can be readily obtained by short-circuiting the output

$$Z_{\text{total}} = \frac{Z_1 \left[Z_2 + \frac{Z_3 (Z_4 + Z_5)}{Z_3 + Z_4 + Z_5} \right]}{Z_1 + \left[Z_2 + \frac{Z_3 (Z_4 + Z_5)}{Z_3 + Z_4 + Z_5} \right]} \quad (32)$$

$$Z_{\text{total}} = \frac{Z_1 Z_2 Z_3 + Z_1 Z_2 Z_4 + Z_1 Z_2 Z_5 + Z_1 Z_3 Z_4 + Z_1 Z_3 Z_5}{Z_1 Z_3 + Z_1 Z_4 + Z_1 Z_5 + Z_2 Z_3 + Z_2 Z_4 + Z_2 Z_5 + Z_3 Z_4 + Z_3 Z_5} \quad (33)$$

If one defines

$$Z_1 = R_2$$

$$Z_2 = Z_3 = \frac{1}{C_1 s}$$

$$Z_4 = \frac{1}{C_2 s}$$

$$Z_5 = R_1$$

The network of figure 8 is obtained and the transfer impedance becomes, after some tedious but straightforward manipulations:

$$Z_{\text{total}} = R_2 \left(\frac{1 + A s}{B^2 s^2 + C s + 1} \right) \quad (34)$$

$$\left. \begin{aligned} \text{where } A &= \frac{2 R_1 C_1 C_2}{2 C_1 + C_2} \\ B &= \frac{R_1 R_2 C_1^2 C_2}{2 C_1 + C_2} \\ C &= \frac{C_1 (2 R_1 C_2 + R_2 C_1)}{2 C_1 + C_2} \end{aligned} \right\} \quad (35)$$

Since the overall transfer function of an operational amplifier is given by the ratio of the feedback to the input impedances, the insertion of identical networks for the two impedances, as shown in figure 9, results in the form:

$$\frac{e_o}{e_{in}} = - \frac{(1 + A' S) (B S^2 + D S + 1)}{(1 + A S)(B' S^2 + D' S + 1)} \quad (36)$$

it is evident that if A is constrained to be equal to A', a transfer function of the desired form obtains.

In inverse filtering the numerator coefficients B and C are forced to match those of the undesired filter function, whereas B' and D' are made to be a multiple of B and D, hence extending the overall system bandwidth. Thus one can express (36) in the form

$$\frac{e_o}{e_{in}} = - \frac{\frac{S^2}{\omega_n^2} + \frac{2\zeta_1}{\omega_n^2} + 1}{\frac{S^2}{K^2 \omega_n^2} + \frac{2\zeta_2}{K \omega_n} + 1} \quad (37)$$

where K is a positive number relating the new break frequency to the one being cancelled. Since the damping ratios may or may not be the same, they are maintained as distinct quantities. Invocation of equations (35), (36), and (37) is sufficient to define the circuit components in terms of the filter parameters, but these equations are unwieldy. Great simplification is possible by introducing a couple of constraints

$$A' = A = D/10$$

$$R_2 = R_2'$$

The first of these moves the first order terms to be cancelled to a high frequency region, where possible mismatches would be inconsequential; it does limit K, but values up to 6 are allowed, thus covering the range of practical interest. The second constraint merely assures unity d.c. gain.

Implementation of the above, coupled with insertion of the basic parameters, yield the component specifications

$$\left. \begin{aligned}
 R_1 &= R_2 \left(\frac{\zeta_1^2}{100 - \zeta_1^2} \right) & R_1' &= \frac{R_2}{4} \left(\frac{\zeta_1^2}{K\zeta_1(K\zeta_1 - 10\zeta_2) + 25} \right) \\
 C_1 &= \frac{1}{R_2} \left(\frac{10}{\zeta_1 \omega_n} \right) & C_1' &= \frac{1}{R_2} \left(\frac{10}{K^2 \zeta_1 \omega_n} \right) \\
 C_2 &= \frac{1}{R_1} \left(\frac{5}{9\zeta_1 \omega_n} \right) & C_2' &= \frac{1}{R_1} \left(\frac{5}{K\omega_n(10\zeta_2 - K\zeta_1)} \right) \\
 R_2 &= R_2'
 \end{aligned} \right\} (38)$$

R_2 is unrestricted and user selectable. Greater computational simplicity results from the inverse forms for R_1 and R_1'

$$\frac{1}{R_1} = \frac{1}{R_2} \left(\frac{100}{\zeta_1^2} - 1 \right) \approx \frac{1}{R_2} \left(\frac{100}{\zeta_1^2} \right)$$

$$\frac{1}{R_1} = \frac{1}{R_2} \left(4K \left(K - 10 \frac{\zeta_2}{\zeta_1} \right) + \frac{100}{\zeta_1^2} \right)$$

There are certain conditions implied by the R_1' and C_2' specifications since these components must be positive. The most restrictive is that for C_2' where it is required that

$$10\zeta_2 > K\zeta_1$$

which at worst (for $K=6$), requires that $\zeta_2 > 0.6\zeta_1$, a condition that is easily met in almost any practical situation. A design procedure for an inverse filter is now possible

Given

$$\omega_n \text{ (rad/sec)}, K, (K \leq 6) \zeta_1, \zeta_2$$

a. Select R_2 ($R_2' = R_2$)

b. Compute remaining components using equation(s) (38).

It should be noted that for low frequencies ($\omega < 10$), either R_2 or C_2 must be quite large. This is unavoidable in this network configuration, thus if a very low frequency design is required, alternate forms (ref. 1) may be more appropriate if these large component values are unacceptable.

The network phase shift is given by

$$\Phi_{\text{total}} = \Phi_1 - \Phi_2$$

where Φ_1 and Φ_2 are obtained by applying equation (9) to the numerator (Φ_1) and denominator (Φ_2) of equation (37).

DIGITAL FILTERS

Frequently data that has been acquired and transformed into digital format is found to require additional filtering of any of the types discussed in the Introduction. In the analog domain, each filter type was developed using special dedicated circuit in order to obtain an economical, yet simple practical design. Since a digital filter is generally a software implementation of an algorithm, all five filter types can be realized from the same basic mechanization of the most general form of the second order equation, depicted by

$$\frac{E_o}{E_{in}} = \frac{\frac{s^2}{\omega_1^2} + \frac{2\zeta_1}{\omega_1} s + 1}{\frac{s^2}{\omega_2^2} + \frac{2\zeta_2}{\omega_2} s + 1} \quad (41)$$

Equation (41) can be modeled via a "simulation" block diagram as if it were to be programmed into an analog computer. More than one configuration is possible, but herein the "M" method (ref. 2) will be used. This technique results in an analog computer block diagram as shown in figure 10; in this most general representation, an inverse filter is described, but a notch is readily achieved by simply inserting the appropriate coefficient values (i.e. $\zeta_1 = 0, \omega_1 = \omega_2$). For a low pass filter the numerator of equation (41) needs to be unity, which is obtainable if we let ω_1 approach infinity. If this is done, it is evident from figure 10 that $E_o = X_1$; thus a low pass filter is also obtained from the mechanization of figure 10, by using X_1 as the output.

While less obvious, the high pass configuration is also obtainable from this diagram. Such a filter, with unity gain in the passband is described by

$$\frac{E_o}{E_{in}} = \frac{\frac{s^2}{\omega_2^2}}{\frac{s^2}{\omega_2^2} + \frac{2\zeta_2}{\omega_2} s + 1} \quad (42)$$

From figure 10 one can work backwards from X_1 to the point labeled X_3 , and observe that

$$X_3 = \frac{1}{\omega_2^2} \ddot{X}_1 = \frac{s^2}{\omega_2^2} X_1 \quad (43)$$

But X_1 has already been shown to be the low pass output, thus equation (43) is equivalent to (42) and one obtains the high pass configuration by defining X_3 as the output.

Algorithm Development. The derivation of a digital filter can be obtained via the state space equations that describes the system shown in figure 9. The state equations are discretized and then solved, and the solution iterated over time. This technique was originally described in reference 3, and is briefly repeated herein for completeness. From the figure, the vector-matrix filter equations are readily obtained

$$\begin{bmatrix} \dot{X}_1 \\ \dot{X}_2 \end{bmatrix} = \begin{bmatrix} 0 & 1 \\ \omega_2^2 & -2\zeta_2 \omega_2 \end{bmatrix} \begin{bmatrix} X_1 \\ X_2 \end{bmatrix} + \begin{bmatrix} 0 \\ \omega_2^2 \end{bmatrix} E_{in} \quad (44)$$

E_{out} is obtainable as a linear combination of X_1 and X_2

$$E_{out} = \frac{\omega_2^2}{\omega_1^2} E_{in} + \frac{(1 - \omega_2^2)}{\omega_1^2} X_1 + \frac{(2\zeta_1 \omega_1 - 2\zeta_2 \omega_2)}{\omega_1^2} X_2 \quad (45)$$

The above vector-matrix differential equation is of the general form

$$\dot{X} = Ax + Bu \quad (46)$$

whose solution is given by:

$$X(t) = e^{At} X(0) + e^{At} \int_0^t e^{-A\tau} Bu(\tau) d\tau \quad (47)$$

Since the data of interest is discrete (due to the digitization process) the solution for the discrete form of subject set of differential equation is needed. A recursive relation exists that allows the computation of the system state at time $(K+1)T$ based on knowledge of the state at time KT ; K is a running index and T is the sampling interval. The recursive relation is given by a formula. (Reference 4)

$$X(K+1)T = G(T) X(KT) + H(T) u(KT) \quad (48)$$

$$\text{where } G(T) = e^{AT}; H(T) = \int_0^T e^{A\tau} d\tau B \quad (49)$$

The solution of the subject difference equation reduces essentially to computing e^{AT} and its integral over T , a tedious, but straightforward task which is rendered simpler by the following substitutions:

$$\zeta_2 \omega_2 = \alpha; \omega = \omega_2 \sqrt{1 - \zeta_2^2} \quad (50)$$

The resulting solution then becomes

$$\begin{bmatrix} x_1(K+1) \\ x_2(K+1) \end{bmatrix} = \begin{bmatrix} A_{11} & A_{12} \\ A_{21} & A_{22} \end{bmatrix} \begin{bmatrix} x_1(K) \\ x_2(K) \end{bmatrix} + \begin{bmatrix} \omega_2^2 & F_{12} \\ \omega_2^2 & F_{22} \end{bmatrix} E_{in}(K) \quad (51)$$

where

$$A_{11} = e^{-\alpha T} (\cos \omega T + \frac{\alpha}{\omega} \sin \omega T) \quad (52)$$

$$A_{12} = \frac{1}{\omega} (e^{-\alpha T} \sin \omega T) \quad (53)$$

$$A_{21} = -\frac{(\alpha^2 + \omega^2)}{\omega} \left[e^{-\alpha T} \sin \omega T \right] \quad (54)$$

$$A_{22} = e^{-\alpha T} [\cos \omega T - \alpha/\omega \sin \omega T] \quad (55)$$

$$F_{12} = \frac{-e^{-\alpha T}}{\omega(\alpha^2 + \omega^2)} (\alpha \sin \omega T + \omega \cos \omega T) + \frac{1}{\alpha^2 + \omega^2} \quad (56)$$

$$F_{22} = A_{12} \quad (57)$$

From the original equation, $E_{out}(K)$ is inferred to be

$$E_{out}(K) = \frac{\omega_2^2}{\omega_1^2} E_{in}(K) + \left(1 - \frac{\omega_2^2}{\omega_1^2}\right) x_1(K) + \frac{(2\zeta_1 \omega_1 - 2\zeta_2 \omega_2)}{\omega_1^2} x_2(K) \quad (58)$$

Therefore, the digital algorithm consists of mechanizing the three equations for $X_1(K+1)$, $X_2(K+1)$ and $E_{in}(K)$. Required inputs are the sequence to be filtered $E_{in}(K)$, and the initial states $X_1(0)$ and $X_2(0)$ if known. If the input sequence to be filtered is non-zero at the start of the process, it is usually sufficient to set $X_1(0) = E_{in}(0)$.

The substitutions (50) were made for convenience in computing certain inverse Laplace transforms. Reinserting the original values into equations (52) through (57) simplifies them considerably; additionally, (54) through (57) can be expressed in terms of (52) and (53) as follows:

$$A_{11} = e^{-\zeta_2 \omega_2 T} \left(\cos \beta \omega_2 T + \frac{\zeta_2}{\beta} \sin \beta \omega_2 T \right) \quad (59)$$

$$A_{12} = \frac{1}{\omega_2 \beta} \left(e^{-\zeta_2 \omega_2 T} \sin \beta \omega_2 T \right) \quad (60)$$

$$\beta = \sqrt{1 - \zeta_2^2}$$

$$A_{21} = -\omega_2^2 A_{12} \quad (61)$$

$$A_{22} = -2\zeta_2 \omega_2 A_{12} + A_{11} \quad (62)$$

$$F_{12} = \frac{1}{\omega_2^2} (1 - A_{11}) \quad (63)$$

$$F_{22} = A_{12} \quad (64)$$

Thus the equations to be programmed and solved are

$$X_1(K+1) = [X_1(K) - E_{in}(K)] A_{11} + A_{12} X_2(K) + E_{in}(K) \quad (65)$$

$$X_2(K+1) = [E_{in}(K) - X_1(K)] (\omega_2^2 A_{12}) + (A_{11} - 2\zeta_2 \omega_2 A_{12}) X_2(K) \quad (66)$$

A typical design procedure would be:

Given ω_1, ζ_1 (if applicable)

ω_2, ζ_2

- a. Select iteration interval T
- b. Compute A_{11} , A_{12} (they are constants for a given filter)
- c. Insert into iteration algorithm

Different filter types are obtained as follows:

Low Pass - Solution of equations (67) and (68) is sufficient, since the filtered output is $X_1(K)$.

High Pass - As previously stated, is given by $X_3(K)$ which is from figure 10

$$X_3(K) = E_{in}(K) - X_1(K) - \frac{2\zeta_2}{\omega_2} X_2(K) \quad (67)$$

Notch - Given by equation (60) simplified by $\omega_1 = \omega_2$ and $\zeta_1 = 0$

$$E_o(K) = E_{in}(K) - \frac{2\zeta_2}{\omega_2} X_2(K) \quad (68)$$

Inverse - Given by equation (58), unaltered.

Bandpass - As in the analog case, realized by circulating data through separate high and low pass filters.

Iteration Interval and Possible Simplifications

The iteration interval T has thus far not been quantified; it should however be sufficient small to avoid aliasing the data, including the noise components to be filtered. It is actually possible to heuristically quantify T in terms of the filter parameters which leads to normalization of the coefficient (A_{11} , A_{12}) equations and opens the door for some very useful simplifications of the filtering algorithm.

The following conjecture is proposed: If a signal needs to be filtered at all, it must have frequency components significantly higher than the filter cutoff, and the assumption of frequencies 10 times ω_2 is not unreasonable. In addition, the sampling frequency must be high enough to reasonably duplicate this component. A minimum specification then can be developed where the sampling frequency should be at least 50 times the filter cutoff.

Defining:

$$\omega_s = \text{sampling frequency} = \frac{1}{T}$$

one obtains, as a result of the above conjecture, the relationship:

$$\frac{\omega_2}{\omega_s} \leq 0.02 \quad (70)$$

It should be noted that $\omega = \frac{1}{T}$ is not a sinusoidal frequency in the strict sense, but it is, nevertheless convenient to use this notation for the sampling rate. Substituting (69) into (59) and (60) yields:

$$A_{11} = e^{-\zeta_2} \frac{\omega_2}{\omega_s} \left(\cos \beta \frac{\omega_2}{\omega_s} + \frac{\zeta_2}{\beta} \sin \beta \frac{\omega_2}{\omega_s} \right) \quad (71)$$

$$A_{12} = \frac{1}{\omega_2 \beta} \left(e^{-\zeta_2} \frac{\omega_2}{\omega_s} \sin \beta \frac{\omega_2}{\omega_s} \right) \quad (72)$$

However, the term $\beta = \sqrt{1 - \zeta_2^2}$ will always be less than unity, and equation (70) is an upper limit for the sine and cosine values in equation (71) and (72). For small angles $\sin X = X$ and $\cos X = 1$, and one can then simplify (71) and (72).

$$A_{11} = e^{-\zeta_2} \frac{\omega_2}{\omega_s} \left(1 + \zeta_2 \frac{\omega_2}{\omega_s} \right) \quad (73)$$

$$A_{12} = \frac{1}{\omega_s} e^{-\zeta_2} \frac{\omega_2}{\omega_s} \quad (74)$$

These equations are accurate to better than 0.02% subject to the constraint of (70). Even when the ratio of ω_2/ω_s is as large as 0.1, the equations retain an error of < 0.5%.

Equation (73) can be further examined in terms of the parameters ζ_2 and ω_2/ω_s . Computation of A_{11} in the ranges $\omega_2/\omega_s \leq .02$ and $0.1 \leq \zeta_2 \leq 0.8$ yields values for A_{11}

ranging from 0.99 to 0.998. Hence, A_{11} is, for all practical purposes, unity, resulting in the following simplified set of filter equations, which in addition to the above simplification have had A_{12} replaced by a new variable $B_{12} = \omega_2 A_{12}$. This step normalizes B_{12} and one can pre-compute it as a function of the damping and frequency ratios:

$$X_1(K+1) = X_1(K) + \frac{B_{12}}{\omega_2} X_2(K) \quad (75)$$

$$X_2(K+1) = \left[E_{in}(K) - X_1(K) \right] \omega_2 B_{12} + (1 - 2\zeta_2 B_{12}) X_2(K) \quad (76)$$

$$B_{12} = \frac{\omega_2}{\omega_s} e^{-\zeta_2 \frac{\omega_2}{\omega_s}} \quad (77)$$

A non-transcendental approximation for (77) is given by:

$$B_{12} \approx (1 - .1\zeta_2) \frac{\omega_2}{\omega_s} \quad (78)$$

The accuracy of this linear approximation is biased in favor of the smaller values of ζ_2 , the less stable region for the algorithm.

The areas of applicability for the approximate forms will be discussed in some detail in the experimental results section. Where useable, these forms are obviously simpler to implement and the coefficients readily calculated. This is particularly handy for "on-line" microcomputer applications: These devices frequently do not have a hardware multiply and divide capability, and since one usually has some selection flexibility on filter parameters, it is often possible to constrain these to integral powers of 2 (or summations thereof). This reduces all computations to no more than add (or subtract) and shift operations, thus greatly reducing execution time. The exact equations and related coefficients are summarized in Table 1; Table 2 consolidates the various approximation levels discussed.

EXPERIMENTAL RESULTS

Analog mechanizations for low pass, high pass, and notch filters are illustrated in figures 11 - 13. Figure 14 shows a cascaded combination of a 150 Hz low pass filter and a 400 Hz notch.

Both approximate and exact digital low pass and high pass configurations, are illustrated in figures 15 and 16. Figures 17 and 18 depict a low pass configuration with low damping ratio ($\zeta = .2$), which while not a useful filter form does indicate the applicability of the algorithm to the more general problem of transfer function simulation.

Figures 19 - 22 illustrate the effect of the various approximations and sampling rates on the relative quality of notch achievable. Finally, the applicability of the digital implementation to the general 2nd order/2nd order transfer function (inverse filter) is illustrated in figures 23 and 24.

It is evident that, with the exception of the notch filter, in almost all cases it makes little difference which form of the equations and coefficients are used; consequently, (for $T \leq .02$) one might as well use the simplest implementation possible. The notch filter is not unexpectedly, somewhat more sensitive to approximations; here the designer must weigh the filtering requirements versus design simplicity.

One additional point should be made with respect to the *digital implementations*: In addition to the effects of algorithm mechanizations, the designer should be aware of the contribution that the truncated arithmetic of the computer itself might make, a point not directly addressed herein, but implicitly evident in the notch filter illustrations.

The theoretical algorithm (equation 68) yields an infinite notch which was obviously not achieved just as it was not in the analog case. Whereas the analog degradation is attributable to component imperfections, the digital one is caused by computational "imperfections." The illustrated filters were implemented on a 16 bit minicomputer utilizing FORTRAN and single precision arithmetic. The utilization of longer word length computers and/or multiple precision arithmetic will significantly improve the quality of the notch. The relative ranking of the various approximate forms would likely remain the same at this higher performance level.

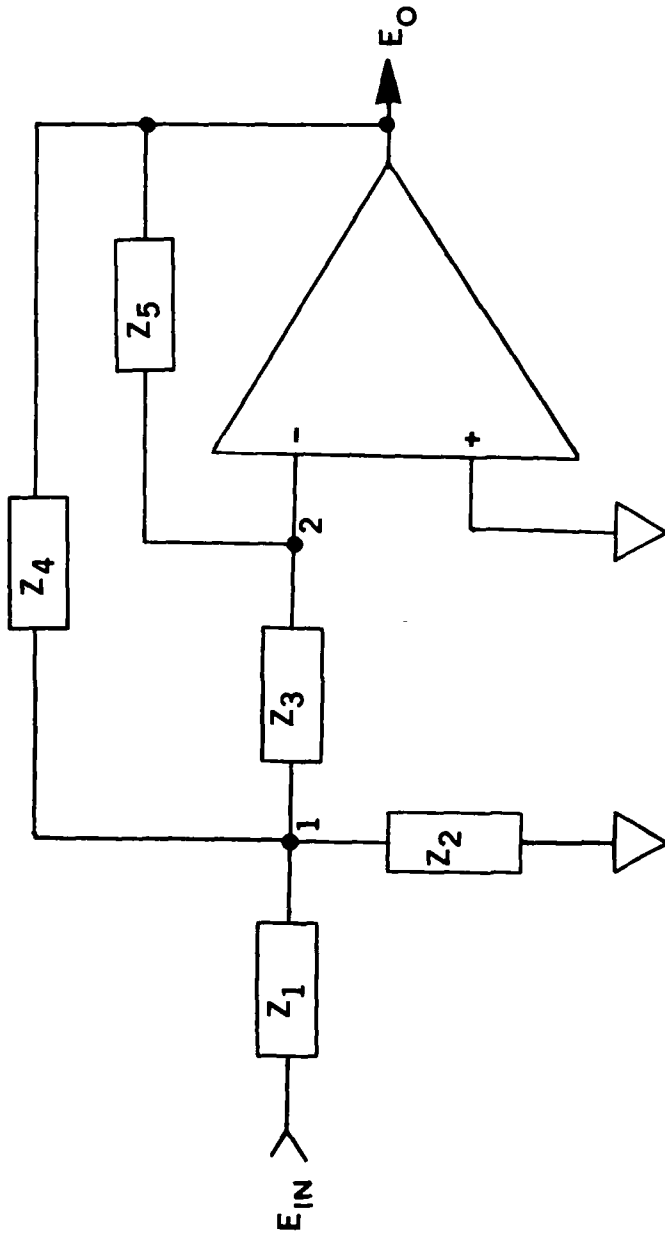
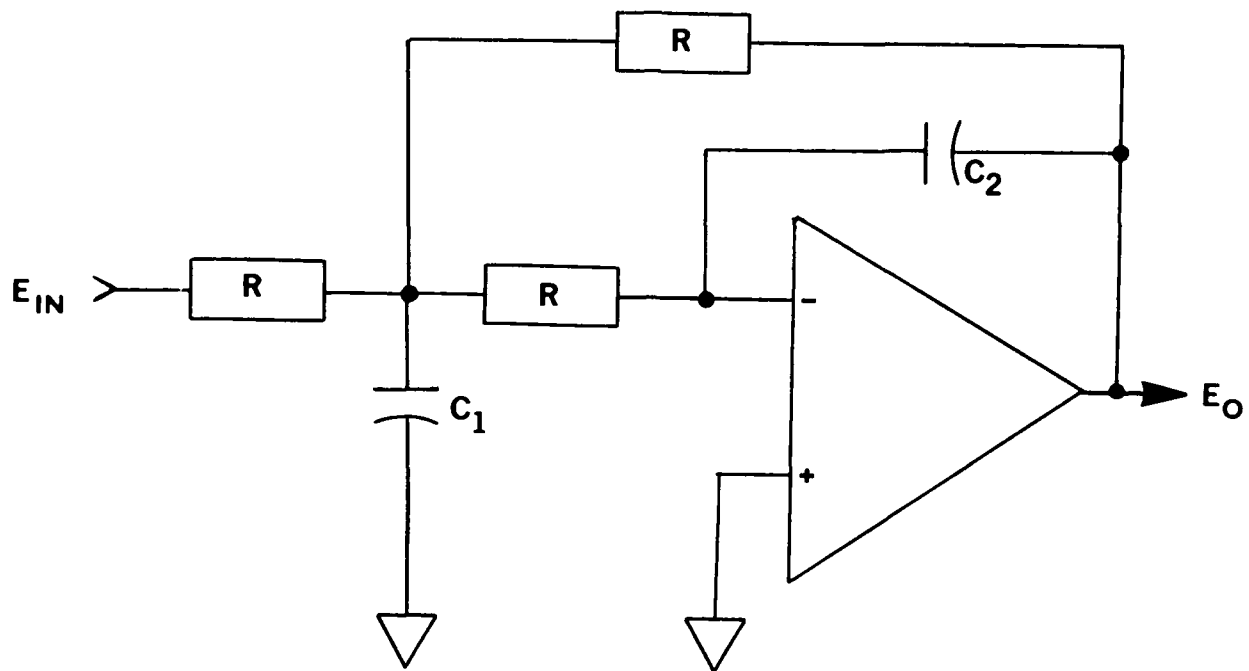

FIGURE 1 FIVE-IMPEDANCE NETWORK



MEGOHMS
AND
MICROFARADS

$$\left\{ \begin{array}{l} C_2 = \text{SELECTED} \\ C_1 = 2.25C_2/\zeta^2 \\ R = \zeta/1.5C_2\omega_N \\ \omega_N = 2\pi f_N \end{array} \right.$$

FIGURE 2 LOW-PASS FILTER

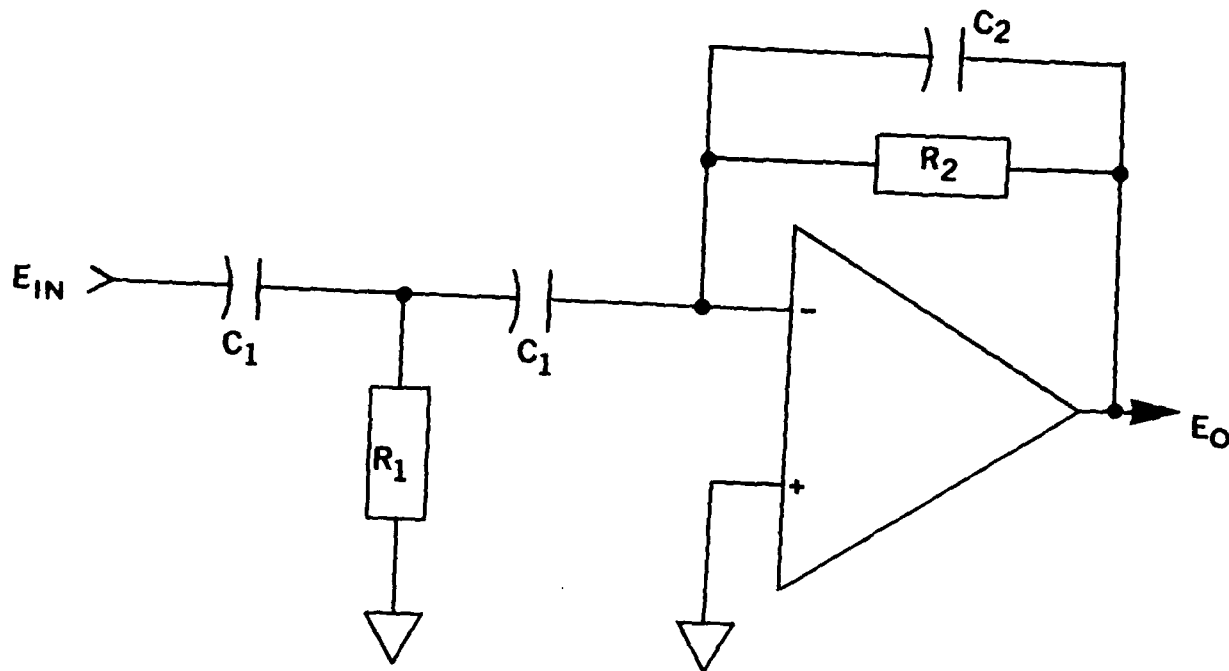

MEGOHMS
AND
MICROFARADS

$$\begin{cases} C_1, G_p = \text{SELECTED} \\ C_2 = C_1 / 2G_p \\ R_1 = 1 / 2\omega_N C_1 \\ R_2 = 1 / \omega_N C_2 \\ \omega_N = 2\pi f_N \end{cases}$$

FIGURE 3 HIGH-PASS FILTER

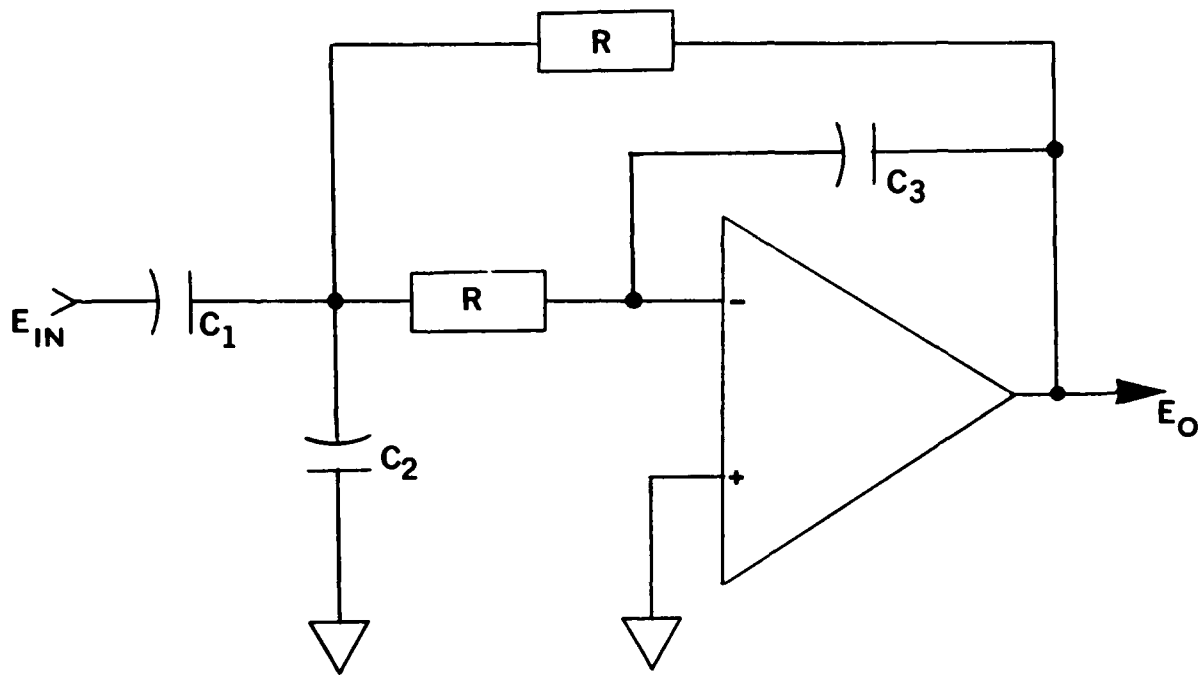
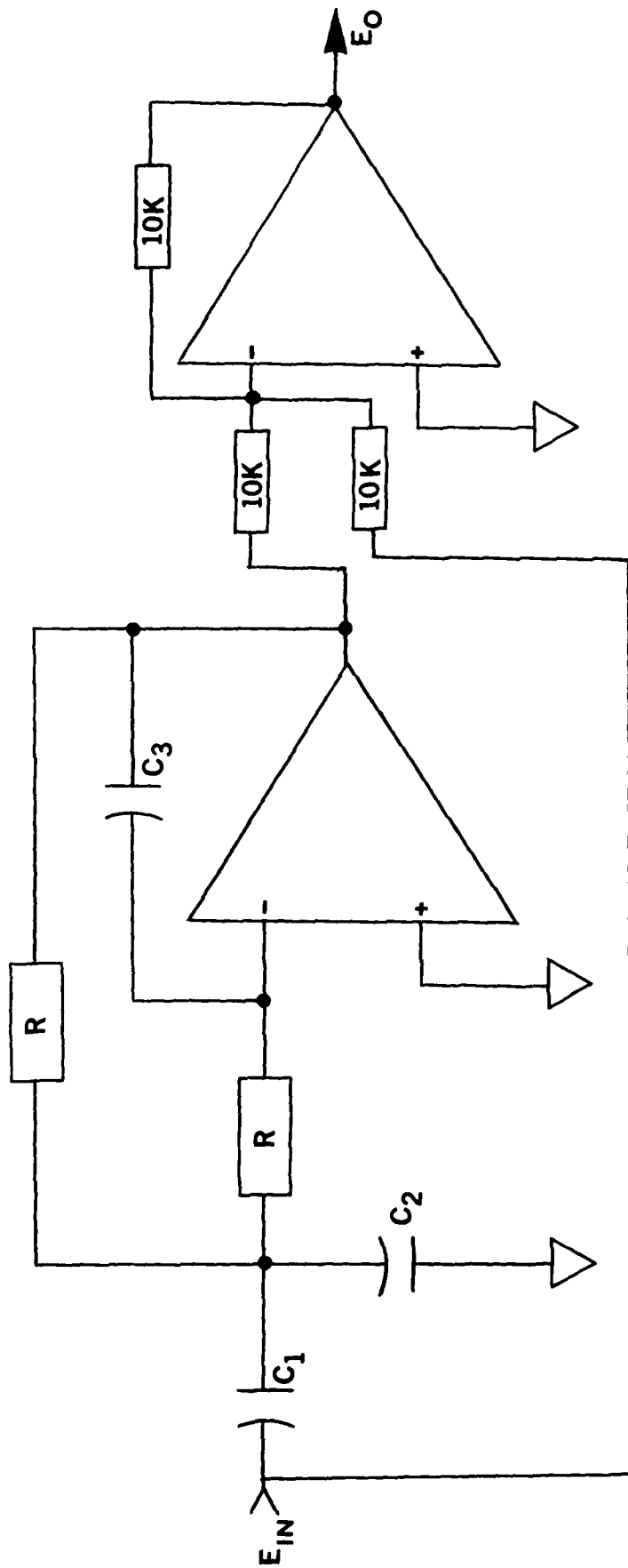
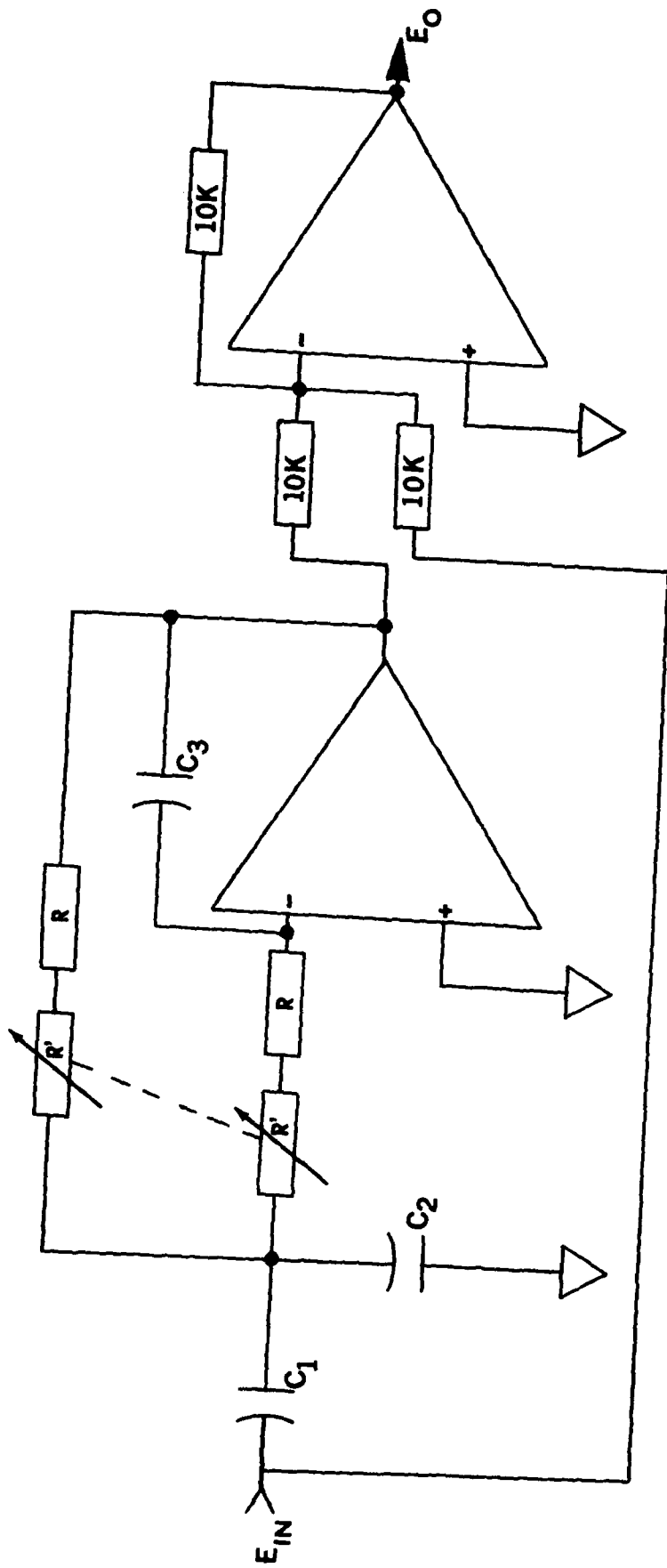

FIGURE 4 1ST/2ND ORDER FORM



$C_1, \zeta_D = \text{SELECTED}$ $C_3 = C_1/2$ $\omega_N = 2\pi f_N$
 MEGOHMS MICROFARADS $R = 1/\omega_N \zeta_D [C_1 + C_2]$
 $C_2 = (1 - 2\zeta_D^2) C_1 / 2\zeta_D^2$

FIGURE 5 NOTCH FILTER



MEGOHMS
AND
MICROFARADS

$$\left\{ \begin{array}{l} C_1, \zeta_D = \text{SELECTED} \\ C_2 = [1 - 2\zeta_D^2] C_1 / 2\zeta_D^2 \end{array} \right.$$

$$C_3 = C_1 / 2$$

$$[R + R'] = 1 / \omega_N \zeta_D (C_1 + C_2)$$

$$\omega_N = 2\pi f_N$$

$$\zeta_D = C_3 \sqrt{1 / C_1 (C_1 + C_2)}$$

FIGURE 6 TUNEABLE NOTCH FILTER

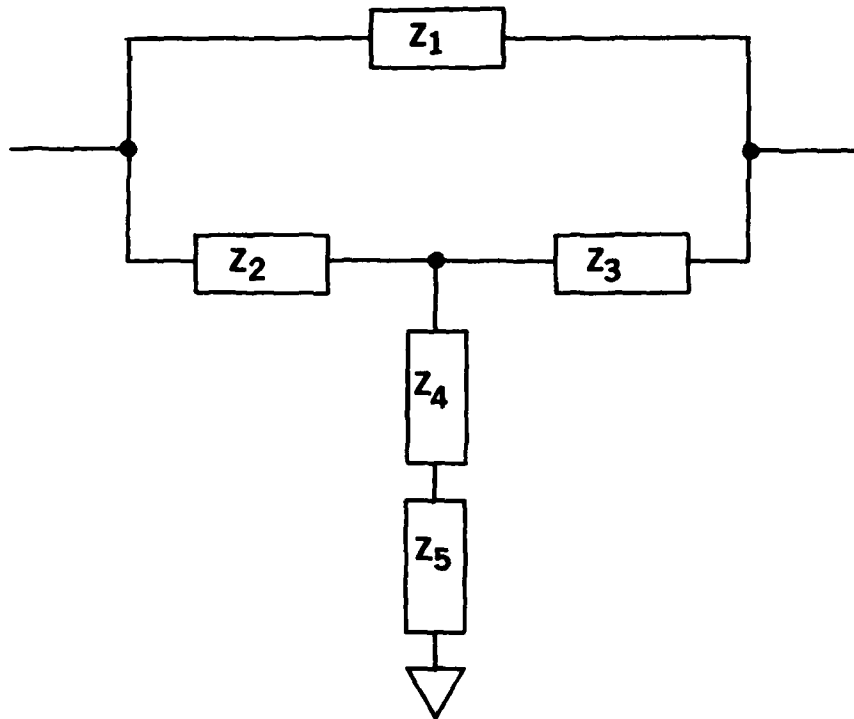

FIGURE 7 GENERAL BRIDGED-T NETWORK

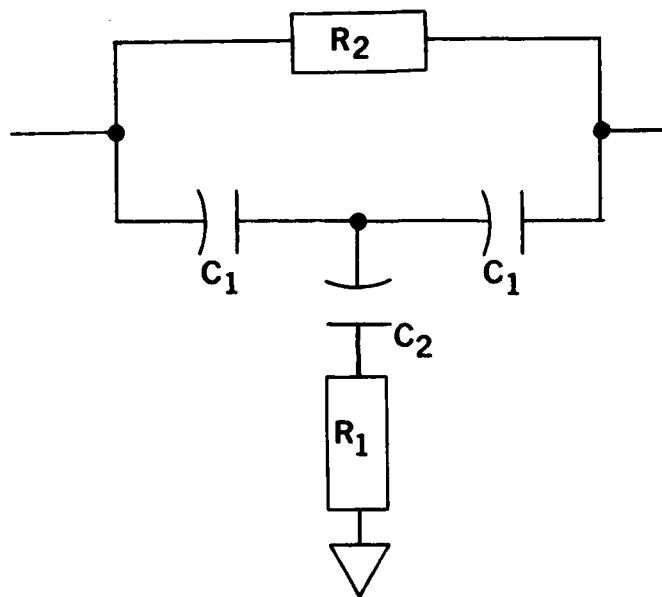

FIGURE 8 NETWORK FOR INVERSE FILTER

$$R_2 = R'_2 = \text{SELECTED} \quad R'_1 = R_2 \zeta_1^2 / 4K \zeta_1 [K \zeta_1 - 10 \zeta_2] + 25$$

$$R_1 = R_2 [\zeta_1^2 / 100 - \zeta_1^2] \quad C'_1 = 10 / R_2 K^2 \zeta_1 \omega_N$$

$$C_1 = 10 / R_2 \zeta_1 \omega_N \quad C'_2 = 5 / R'_1 K \omega_N [10 \zeta_2 - K \zeta_1]$$

$$C_2 = 5 / 9 R_1 \zeta_1 \omega_N \quad \omega_N = 2 \pi f_N$$

MEGOHMS AND MICROFARADS

CONSTRAINTS
 $K \leq 6$
 $\zeta_2 > 0.1 K \zeta_1$

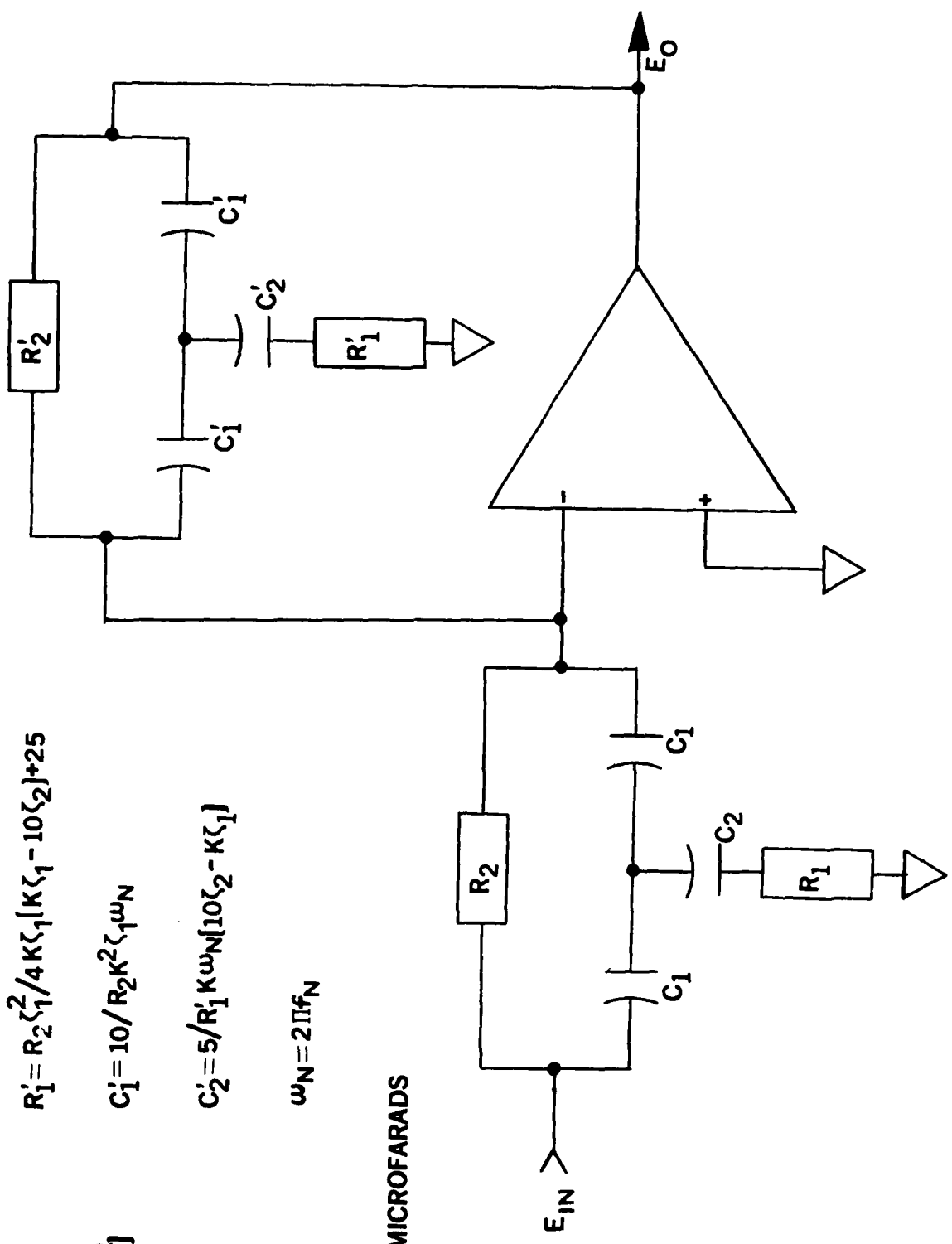

FIGURE 9 INVERSE FILTER

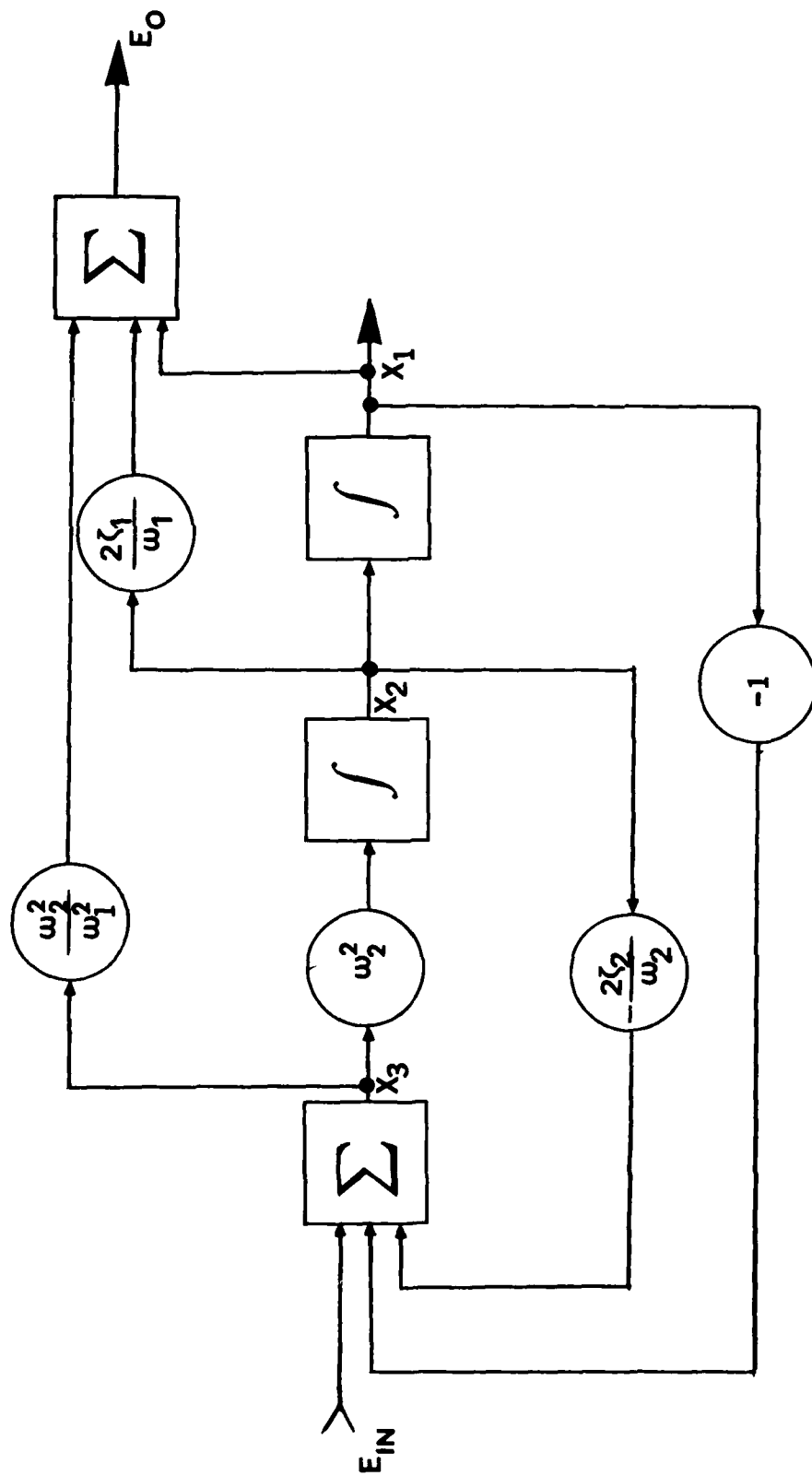

FIGURE 10 SIMULATION MODEL OF 2ND/2ND ORDER TRANSFER FUNCTION

$$\begin{cases} X_1(K+1) = \{X_1(K) - E_{IN}(K)\}A_{11} + A_{12}X_2(K) + E_{IN}(K) \\ X_2(K+1) = \{E_{IN}(K) - X_1(K)\}\omega_2^2 A_{12} + \{A_{11} - 2\zeta_2\omega_2 A_{12}\}X_2(K) \end{cases}$$

$$\text{II} \begin{cases} A_{11} = e^{-\zeta_2\omega_2 T} \{ \cos(\beta\omega_2 T) + \zeta_2/\beta \sin(\beta\omega_2 T) \} \\ A_{12} = 1/\omega_2\beta \{ e^{-\zeta_2\omega_2 T} \sin(\beta\omega_2 T) \} \\ \beta = \sqrt{1 - \zeta_2^2} \end{cases}$$

LOW PASS: $X_1(K)$

HIGH PASS: $E_{IN}(K) - X_1(K) - 2\zeta_2/\omega_2 \{X_2(K)\}$

NOTCH: $E_{IN}(K) - 2\zeta_2/\omega_2 \{X_2(K)\}$

INVERSE: $\{\omega_2^2/\omega_1^2\} \{E_{IN}(K)\} + \{1 - \omega_2^2/\omega_1^2\} X_1(K) + \left[\{2\zeta_1\omega_1 - 2\zeta_2\omega_2\} / \omega_1^2 \right] X_2(K)$

$\omega_i = 2\pi f_i$

$T = 1/\omega_s$; $\omega_s =$ SAMPLING FREQUENCY

TABLE 1 DIGITAL FILTER EQUATIONS

APROXIMATE COEFFICIENTS
 $\omega_2/\omega_s \leq 0.02$

$$I \begin{cases} A_{11} = e^{-\zeta_2 \omega_2 / \omega_s} \{ 1 + \zeta_2 \omega_2 / \omega_s \} \\ A_{12} = e^{-\zeta_2 \omega_2 / \omega_s} \{ 1 / \omega_s \} \end{cases}$$

EQUATIONS SAME AS TABLE 1

APPROXIMATE EQUATIONS

$$II \begin{cases} X_1(K+1) = X_1(K) + \{ B_{12} / \omega_2 \} X_2(K) \\ X_2(K+1) = \{ E_{1N}(K) - X_1(K) \} \omega_2 B_{12} + \{ 1 - 2\zeta_2 B_{12} \} X_2(K) \end{cases}$$

$$III \begin{cases} B_{12} = \omega_2 / \omega_s \{ e^{-\zeta_2 \omega_2 / \omega_s} \} \\ B_{12} \approx \{ 1 - 0.1\zeta_2 \} \omega_2 / \omega_s \end{cases}$$

FILTER TERMS SAME AS TABLE 1

TABLE 2
APPROXIMATIONS FOR DIGITAL EQUATIONS

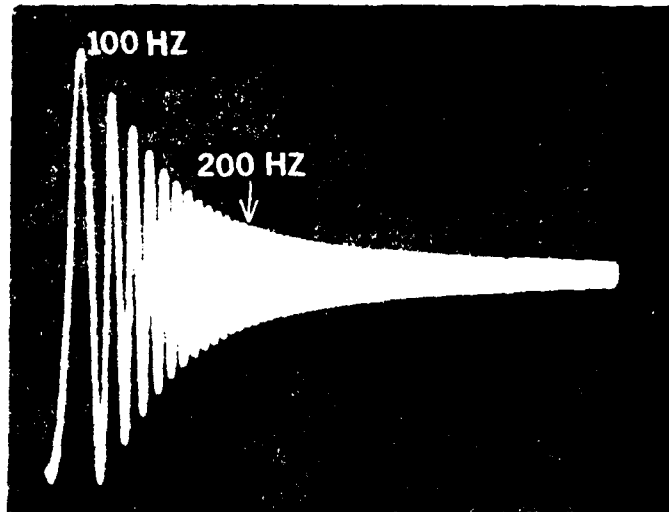

FIGURE 11-LOW PASS

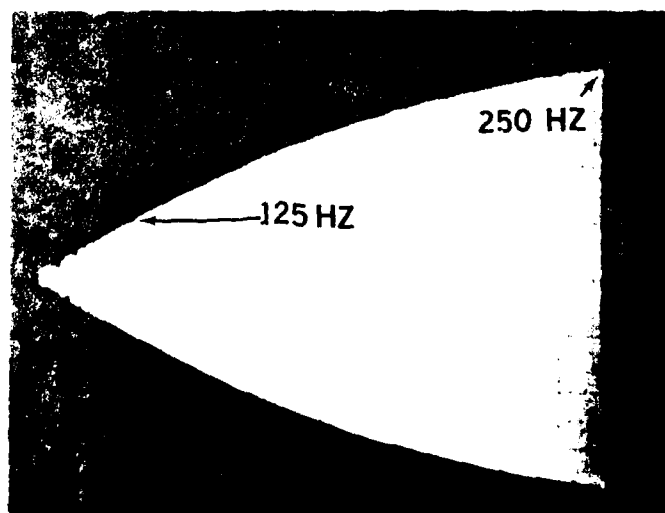

FIGURE 12--HIGH PASS

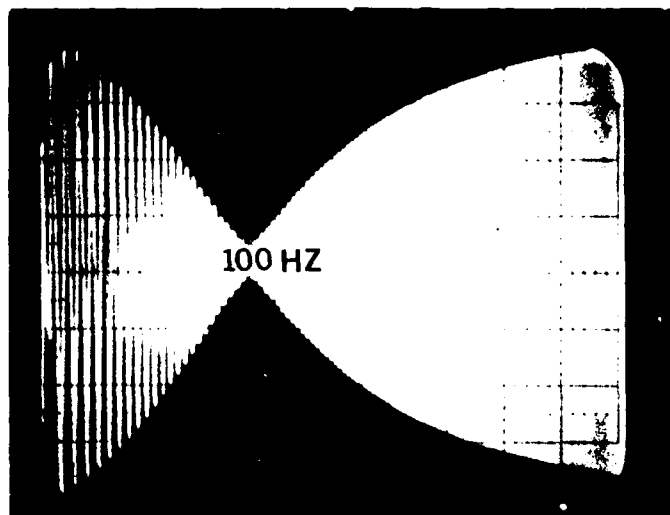

FIGURE 13--NOTCH

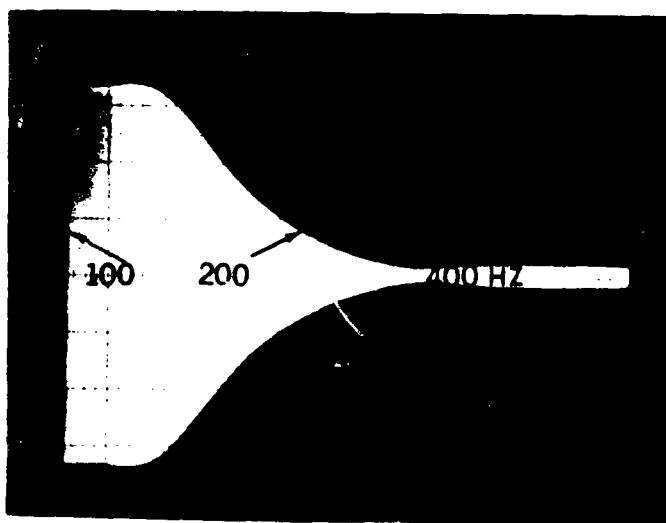
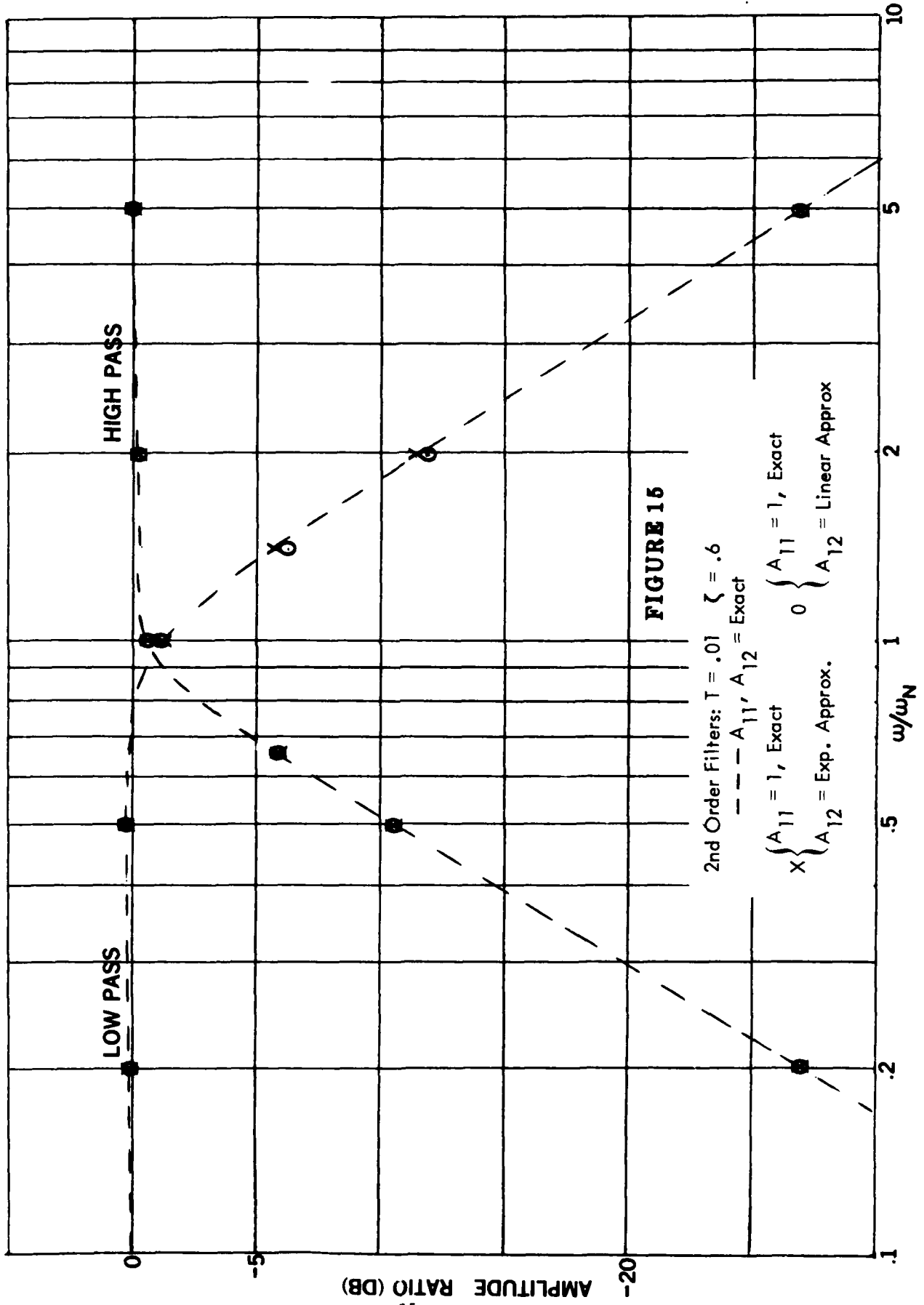
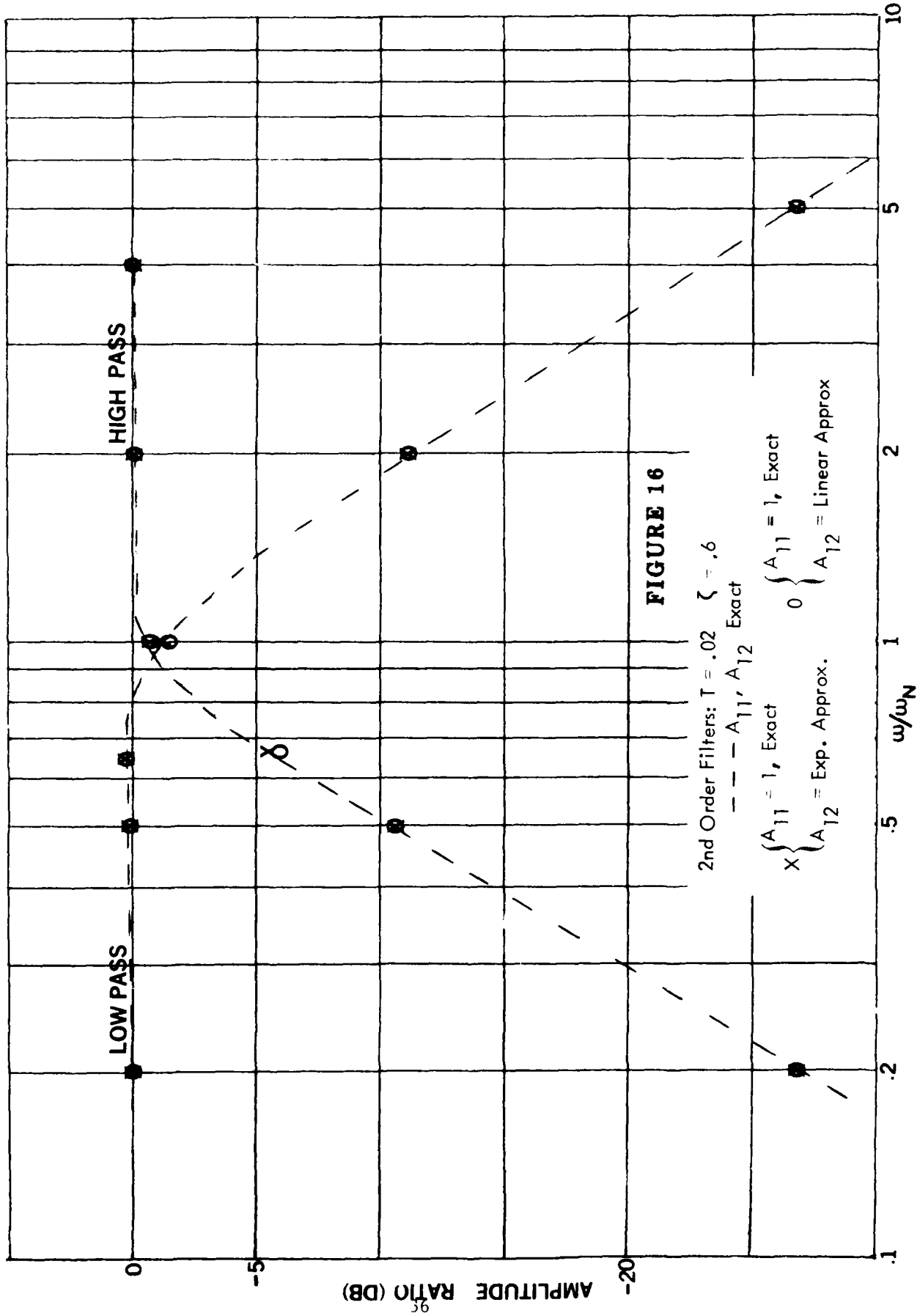

FIG. 14--COMBINATION LOW PASS & NOTCH

FREQUENCY (NORMALIZED)



FREQUENCY (NORMALIZED)



FREQUENCY (NORMALIZED)

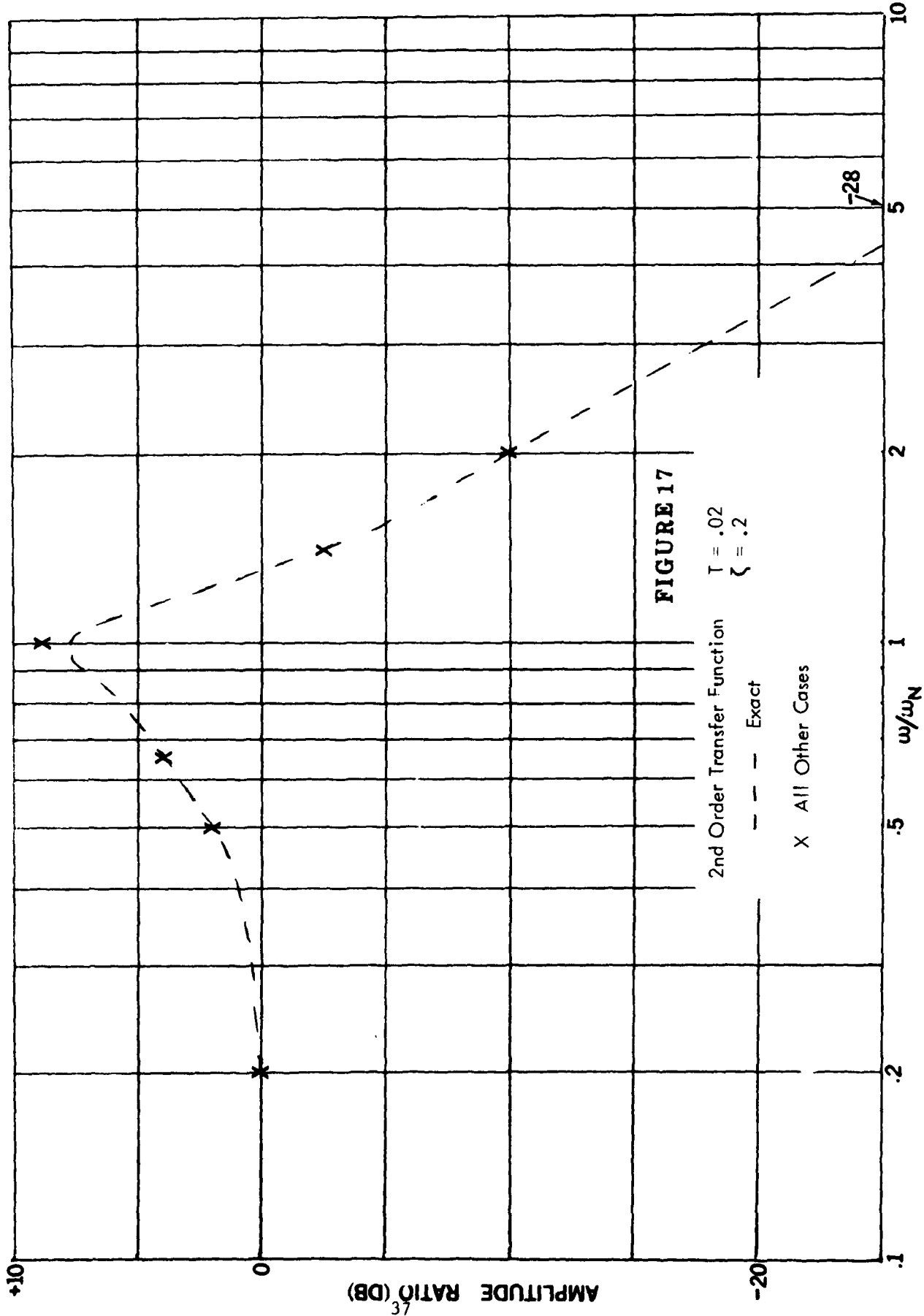

FIGURE 17

$\tau = .02$
 $\zeta = .2$

2nd Order Transfer Function

--- Exact

X All Other Cases

FREQUENCY (NORMALIZED)

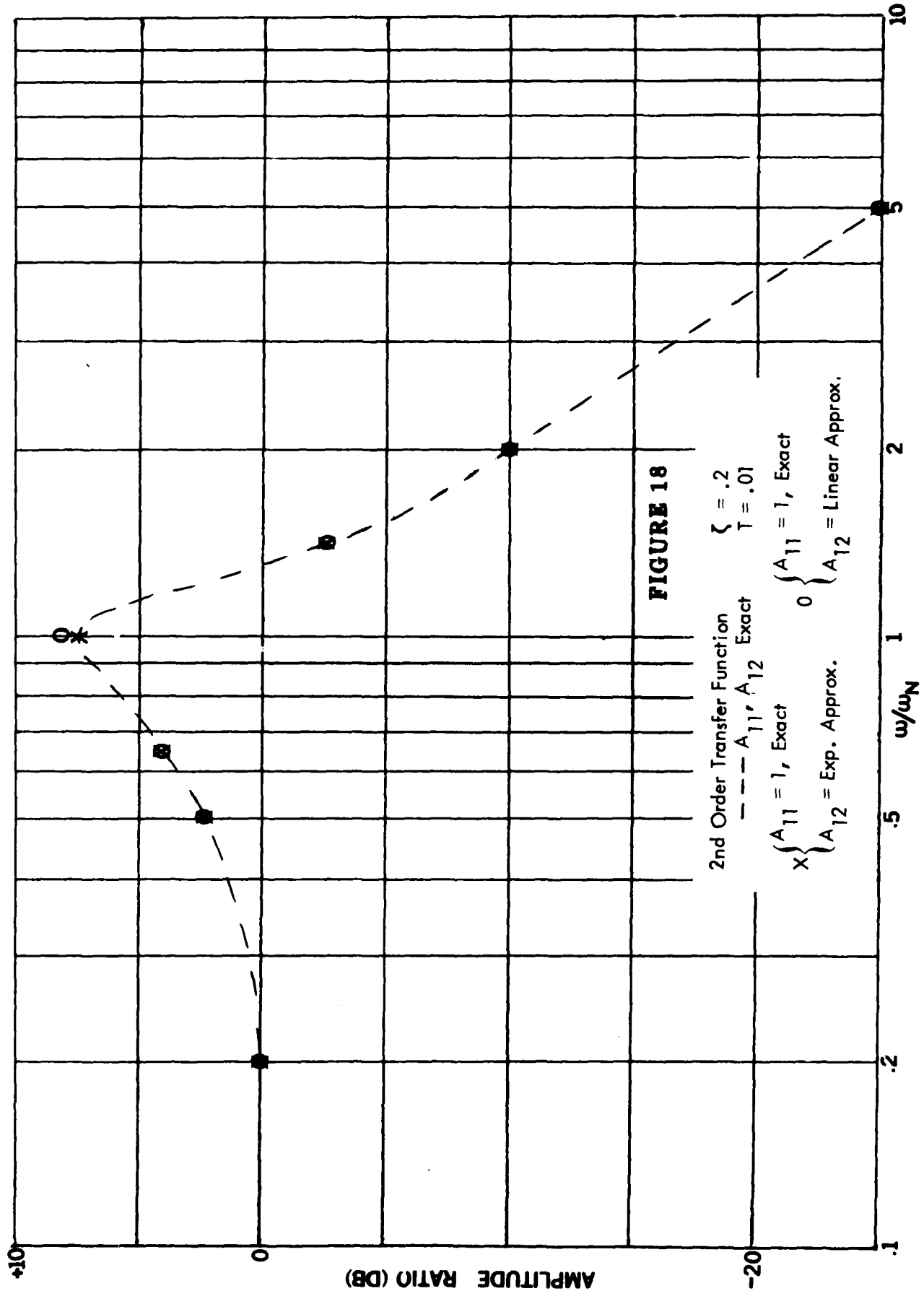

FREQUENCY (NORMALIZED)

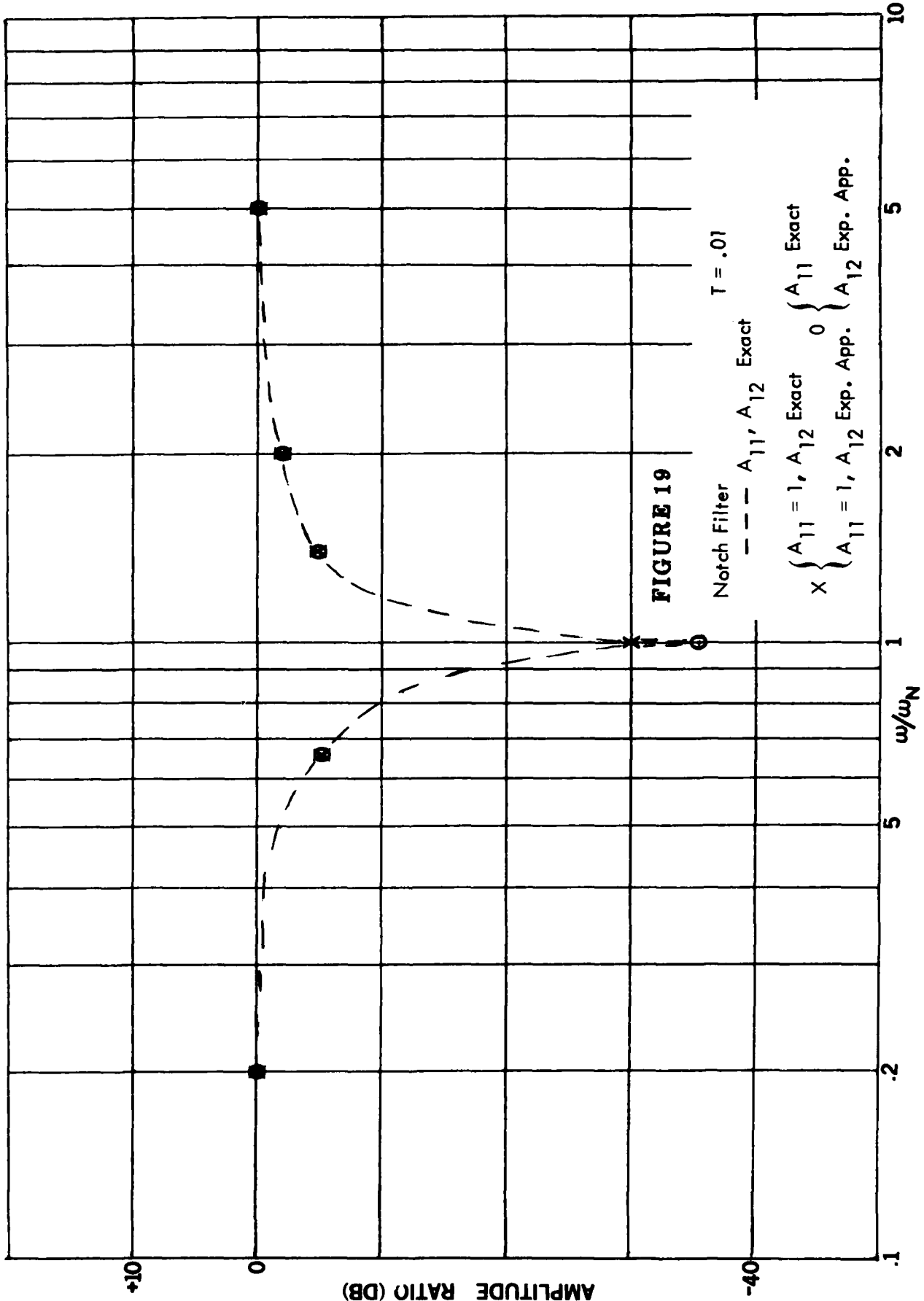

FIGURE 19

FREQUENCY (NORMALIZED)

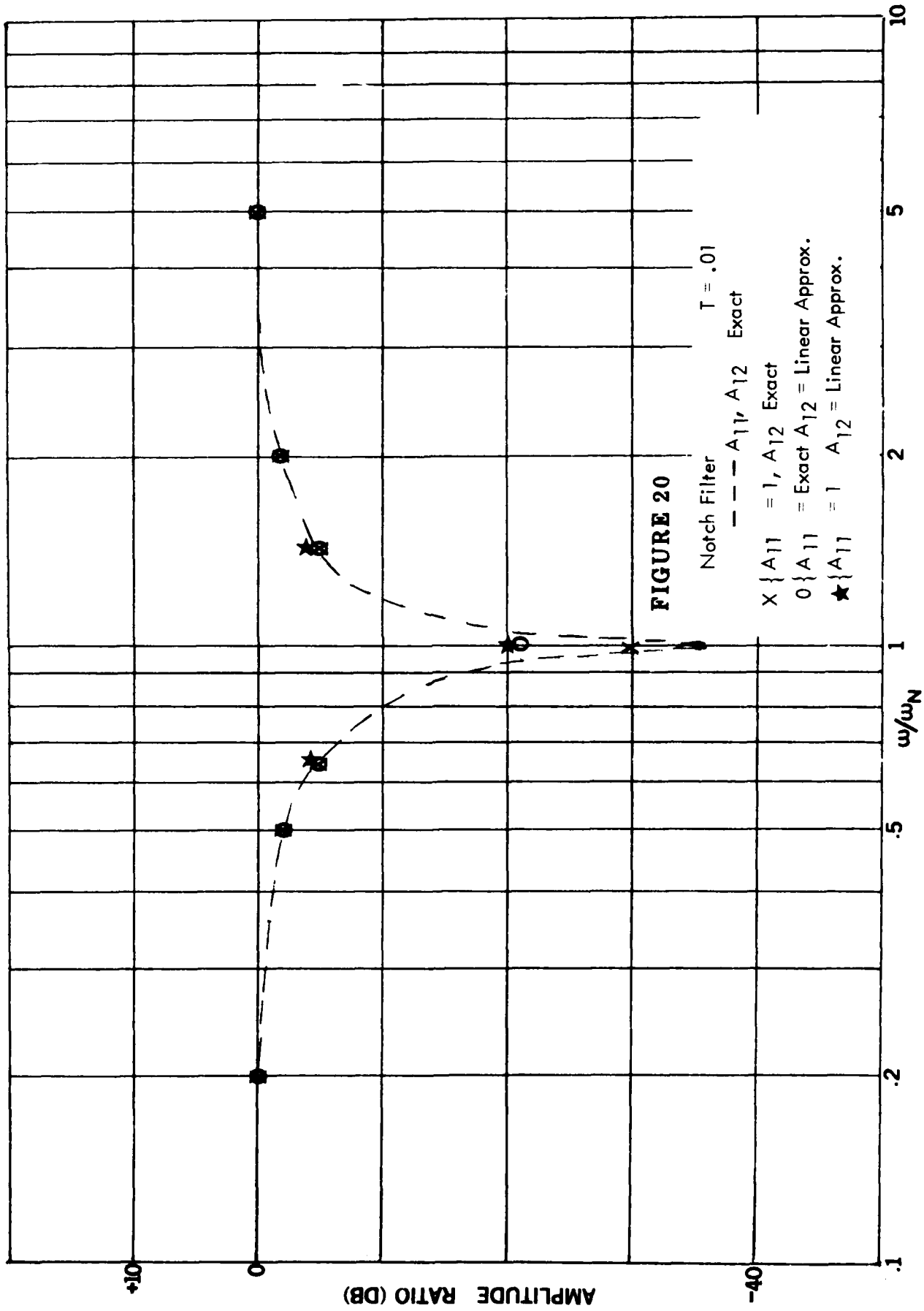

FIGURE 20

Notch Filter $T = .01$
 --- A_{11}, A_{12} Exact
 X $\{ A_{11} = 1, A_{12}$ Exact
 O $\{ A_{11} = \text{Exact } A_{12} = \text{Linear Approx.}$
 ★ $\{ A_{11} = 1, A_{12} = \text{Linear Approx.}$

FREQUENCY (NORMALIZED)

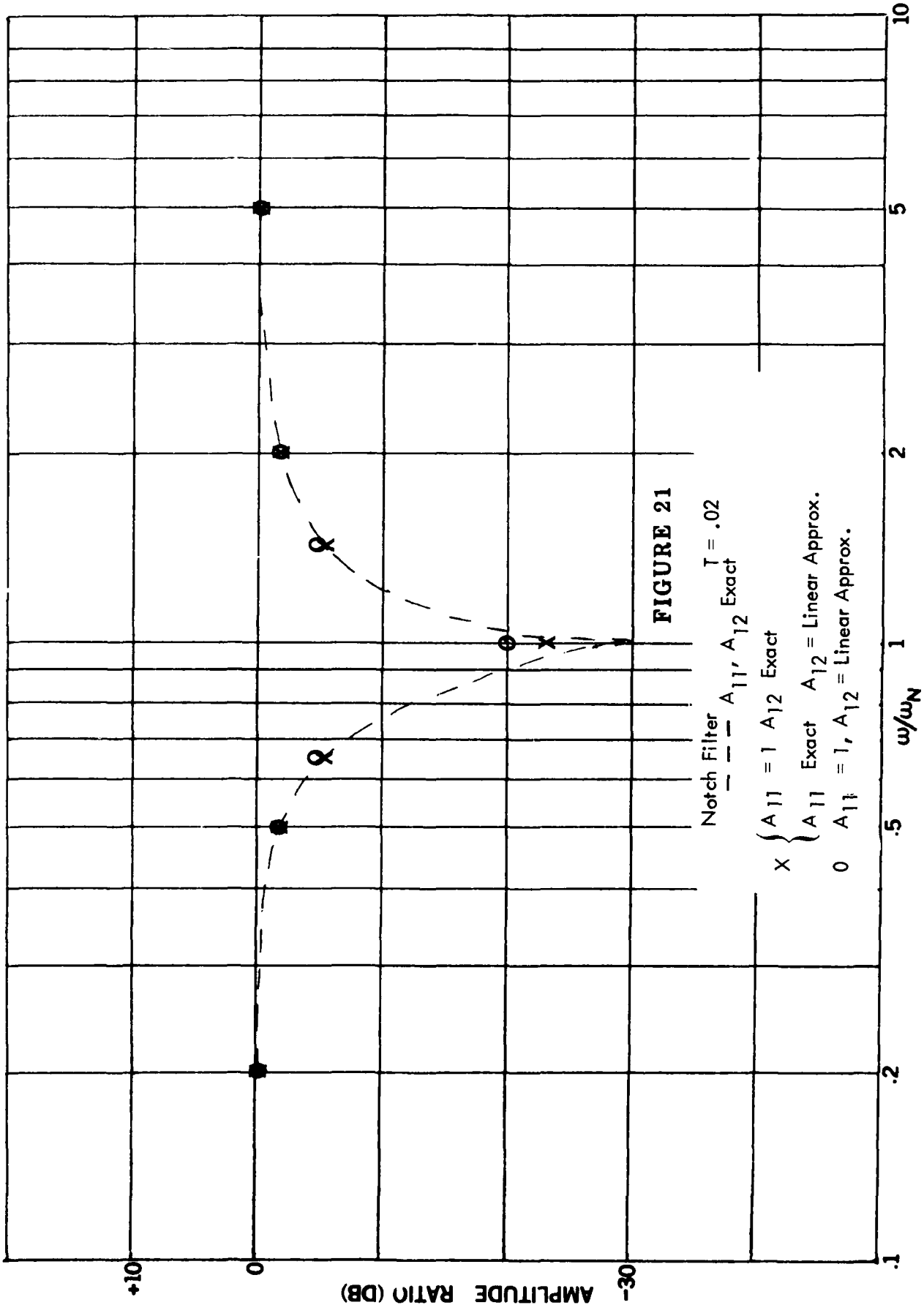

FIGURE 21

Notch Filter $T = .02$
 ———— A_{11}, A_{12} Exact

○ $A_{11} = 1, A_{12}$ Exact
 ○ A_{11} Exact, $A_{12} = 1$ Linear Approx.
 ○ $A_{11} = 1, A_{12} = 1$ Linear Approx.

FREQUENCY (NORMALIZED)

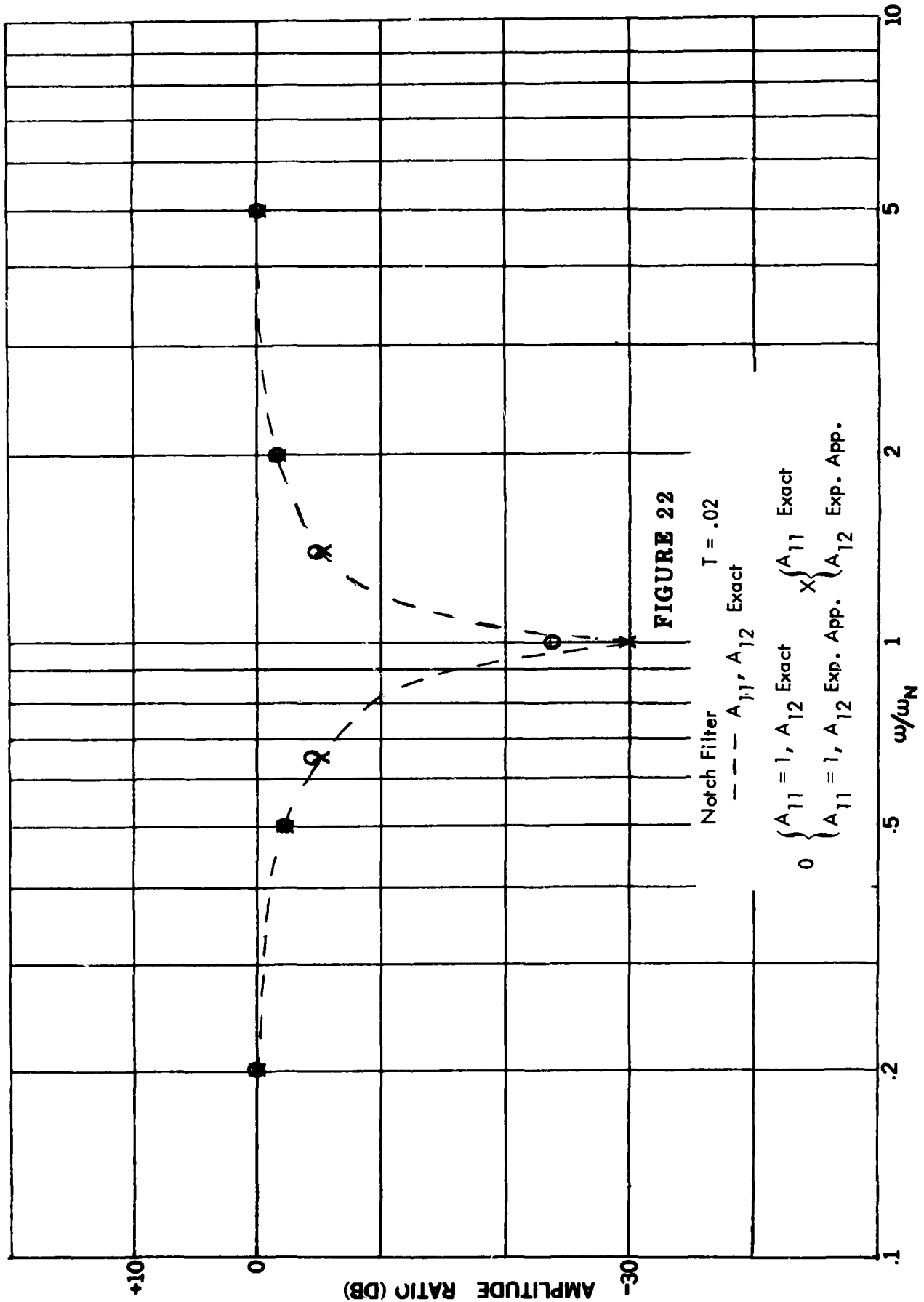

FIGURE 22

$T = .02$

Notch Filter

--- A_{11}, A_{12} Exact

$$0 \begin{cases} A_{11} = 1, A_{12} \text{ Exact} \\ A_{11} = 1, A_{12} \text{ Exp. App.} \end{cases} \begin{cases} X \\ A_{11} \text{ Exact} \\ A_{12} \text{ Exp. App.} \end{cases}$$

FREQUENCY (NORMALIZED)

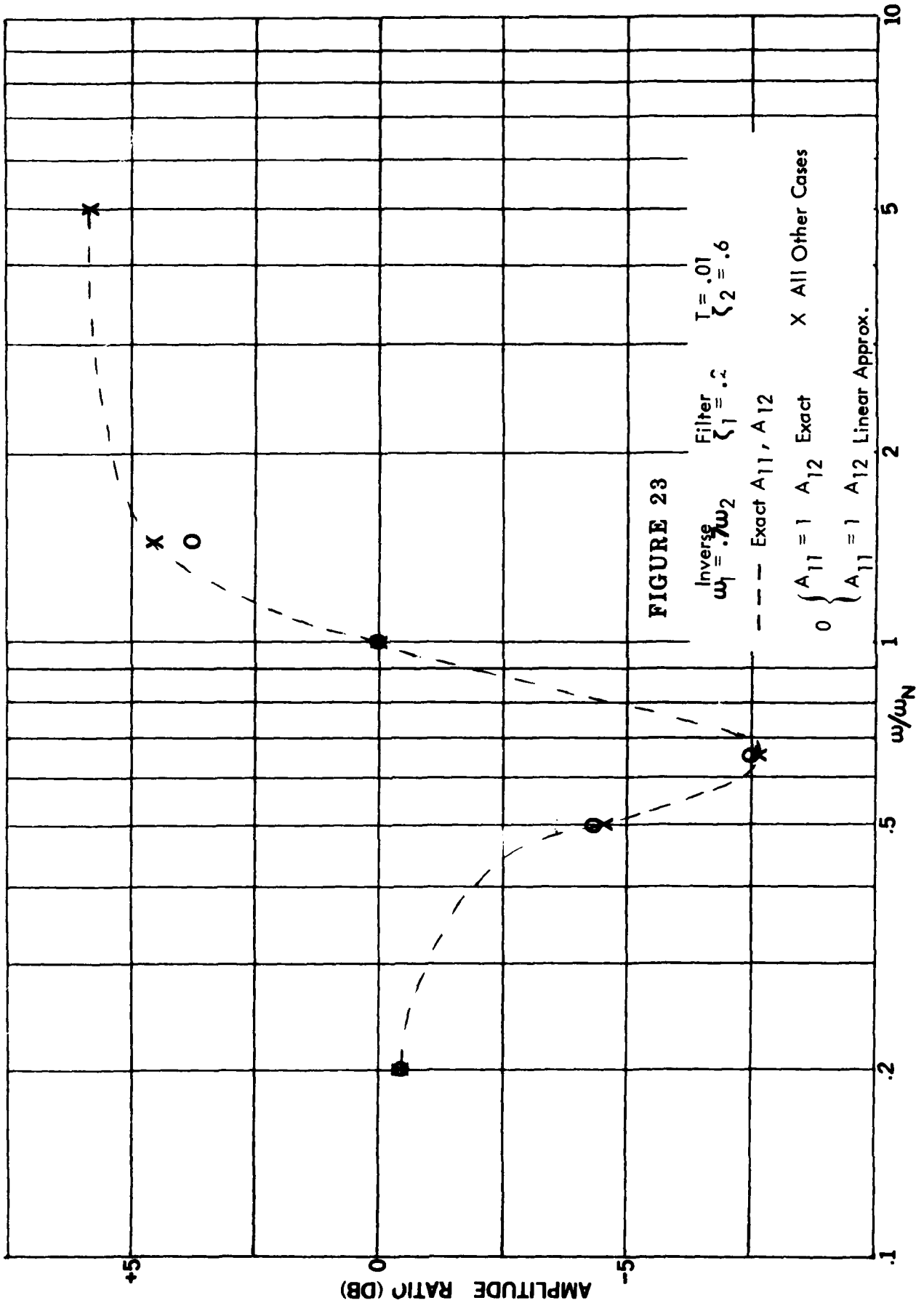

Appendix

An Alternate High Pass Form

The high pass filter discussed in the main body of the report yields real poles only. At times one may need complex poles and in this instance a form very similar to the low pass five impedance network can be obtained by defining:

$$Z_1 = Z_3 = Z_4 = \frac{1}{C}$$

$$Z_2 = R_1$$

$$Z_5 = R_2$$

This yields the network of figure A-1 and the resulting transfer function is given by

$$\frac{e_o}{e_{in}} = \frac{R_1 R_2 C^2 S^2}{R_1 R_2 C^2 S^2 + 3 R_1 C S + 1}$$

with parameters

$$\text{Passband Gain} = 1$$

$$\omega_n = \frac{1}{R_1 R_2 C^2}$$

$$\zeta = 1.5 \sqrt{R_2/R_1}$$

The similarity of the equations to those for the low pass filter is obvious, with the resistors and capacitors interchanging roles. The component definitions are:

$$C = \frac{1}{1.5 R_2} \frac{\zeta}{\omega_n}$$

$$R_1 = \frac{2.25}{\zeta^2} R_2$$

and a proposed design procedure

Select ζ, R_2

Compute R_1

Compute C

All phase shift and time shift equations developed for the low pass case apply without change except that the phase is positive (leading) and the time shift is an advance.

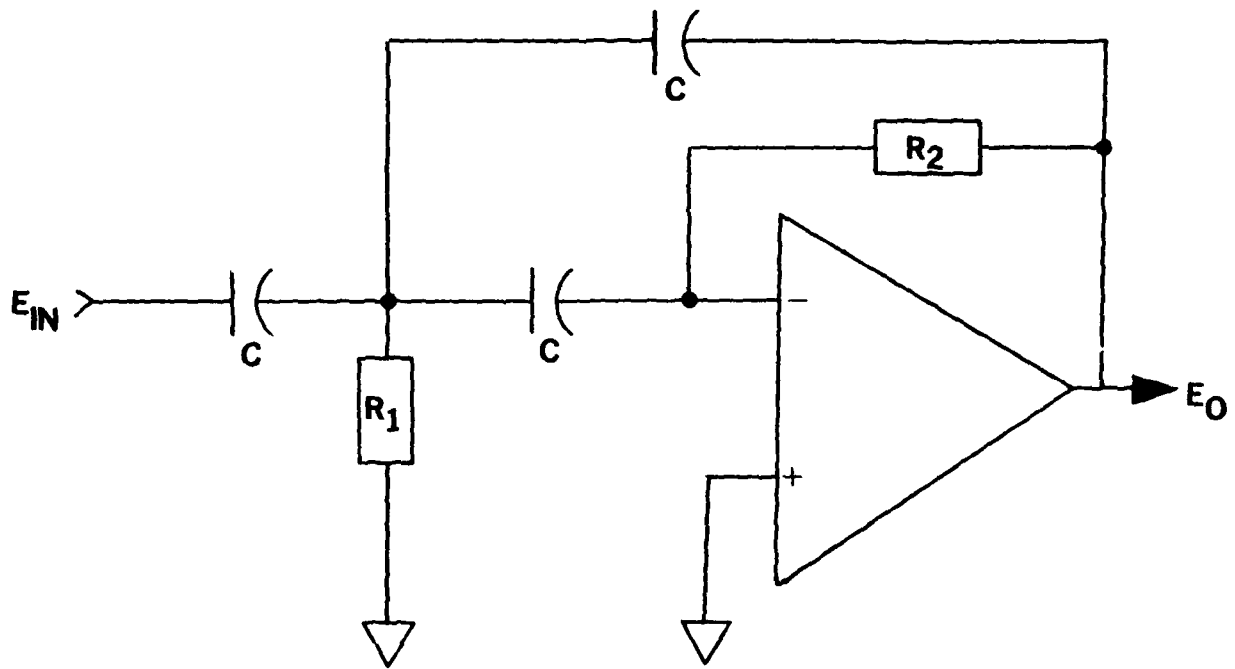

MEGOHMS
AND
MICROFARADS

$$\left\{ \begin{array}{l} R_2 = \text{SELECTED} \\ R_1 = 2.25R_2/\zeta^2 \\ C = \zeta/1.5R_2\omega_N \\ G_p = 1 \\ \omega_N = 2\pi f_N \end{array} \right.$$

FIGURE A-1 ALTERNATE HIGH PASS FORM

REFERENCES

1. Smith, G. and Wood, R., "Principles of Analog Computation." McGraw-Hill, pp. 98 - 104, 1959.
2. Willems, G. and Cook, G., "Put State Variables to Work." Electronic Design, pp. 64 - 71, June 6, 1968.
3. Willems, G. and Anderson, W., "Post Experiment Conditioning of Certain Data Presented in This Report." NAMRL Monograph 21, pp. 128 - 133, August 1972.
4. Ogata, K., "State Space Analysis of Control Systems." Prentice-Hall, pp.336 - 341, 1967.