

LEVEL

12

SSI 8012-7

May 1981

shelter upgrading manual: key worker shelters

FINAL REPORT

JUN 23 1981

Approved for public release:
distribution unlimited

Contract No. EMW-C-0153
Work Unit 1128A

SCIENTIFIC SERVICE, INC.

AD A100511

Unclassified

SECURITY CLASSIFICATION OF THIS PAGE (When Data Entered)

REPORT DOCUMENTATION PAGE		READ INSTRUCTIONS BEFORE COMPLETING FORM
1. REPORT NUMBER 14) SSI-8712-7	2. GOVT ACCESSION NO. AD-A400522	3. RECIPIENT'S CATALOG NUMBER
4. TITLE (and Subtitle) SHELTER UPGRADING MANUAL: KEY WORKER SHELTERS		5. TYPE OF REPORT & PERIOD COVERED Final report
7. AUTHOR(s) R.S./Tansley and R.D./Bernard		6. PERFORMING ORG. REPORT NUMBER
9. PERFORMING ORGANIZATION NAME AND ADDRESS Scientific Service, Inc. 517 East Bayshore, Redwood City, CA 94063		8. CONTRACT OR GRANT NUMBER(s) 15 EMW-C-0153
11. CONTROLLING OFFICE NAME AND ADDRESS Federal Emergency Management Agency Washington, D.C. 20472		10. PROGRAM ELEMENT PROJECT, TASK AREA & WORK UNIT NUMBERS Work Unit 1128A
14. MONITORING AGENCY NAME & ADDRESS (if different from Controlling Office)		12. REPORT DATE 11 May 1981
		13. NUMBER OF PAGES 100
		15. SECURITY CLASS. (of this report)
		15a. DECLASSIFICATION/DOWNGRADING SCHEDULE
16. DISTRIBUTION STATEMENT (of this Report) Approved for public release; distribution unlimited		
17. DISTRIBUTION STATEMENT (of the abstract entered in Block 20, if different from Report) DTIC SELECT JUN 23 1981		
18. SUPPLEMENTARY NOTES C		
19. KEY WORDS (Continue on reverse side if necessary and identify by block number) blast protection; civil defense; crisis relocation planning; fallout protection; key worker; manual; risk area; shelter; upgrading		
20. ABSTRACT (Continue on reverse side if necessary and identify by block number) This manual is one of a series being developed in support of the civil defense concept of crisis relocation planning. One basic element of crisis relocation is plant site protection of key industry people who operate essential facilities through a crisis period. The manual is intended to provide a framework for the practical development of key worker shelters by any interested party. The information contained		

Unclassified

SECURITY CLASSIFICATION OF THIS PAGE (When Data Entered)

herein was developed under Contract EMW-C-0153, Work Unit 1128A, and is based on previously developed structural information, but has yet to be tested in the field.

The manual is designed to be used by planners and plant personnel in risk areas. It presents a methodology for evaluating basement areas and expedient shelters and provides alternative methods to develop the necessary structural upgrading for blast and fallout protection. Expedient shelters are proposed for industries without available basements, and upgrading methods and the resources required for each are presented. Included are sketches and figures that assist in the evaluation of a structure for use as a potential shelter, provide data and charts for closing small openings, and illustrate alternative details of shoring systems. Tables and charts for sizing the shoring or other materials required for each alternative have been provided to simplify applications.

The manual is in looseleaf format so that worksheets, tables, and charts can be removed to develop upgrading plans for a specific structure. This format also allows for the insertion of new data and techniques as they become available.

Accession For	<input checked="" type="checkbox"/>
NTIS GRA&I	<input type="checkbox"/>
Exempt TAB	<input type="checkbox"/>
Justification	
By	
Distribution Codes	
Availability	
Dist	

Unclassified

SECURITY CLASSIFICATION OF THIS PAGE (When Data Entered)

(DETACHABLE SUMMARY)

SSI 8012-7 Final Report
May 1981

Approved for public release;
Distribution unlimited

SHELTER UPGRADING MANUAL:
KEY WORKER SHELTERS

by

R.S. Tansley and R.D. Bernard

for

Federal Emergency Management Agency
Washington, D.C. 20472

Contract No. EMW-C-0153, Work Unit 1128A
Dr. Michael A. Pachuta, Project Officer

FEMA REVIEW NOTICE:

This report has been reviewed in the Federal Emergency Management Agency and approved for publication. Approval does not signify that the contents necessarily reflect the views and policies of the Federal Emergency Management Agency

Scientific Service, Inc.
517 East Bayshore, Redwood City, CA 94063

(DETACHABLE SUMMARY)

SHELTER UPGRADING MANUAL: KEY WORKER SHELTERS

This manual is one of a series being developed in support of the civil defense concept of crisis relocation planning. One basic element of crisis relocation is plant site protection of key industry people who operate essential facilities through a crisis period. The manual is intended to provide a framework for the practical development of key worker shelters by any interested party.. The information contained herein was developed under Contract EMW-C-0153, Work Unit 1128A, and is based on previously developed structural information, but has yet to be tested in the field.

The manual is designed to be used by planners and plant personnel in risk areas. It presents a methodology for evaluating basement areas and expedient shelters and provides alternative methods to develop the necessary structural upgrading for blast and fallout protection. Sections of the manual assist in the selection and identification of potential shelter facilities, explain the choice of upgrading methods, and illustrate the upgrading of various basement alternatives. Expedient shelters are proposed for industries without available basements, and upgrading methods and the resources required for each are presented. Included are sketches and figures that assist in the evaluation of a structure for use as a potential shelter, provide data and charts for closing small openings, and illustrate alternative details of shoring systems. Tables and charts for sizing the shoring or other materials required for each alternative have been provided to simplify applications.

The manual is in looseleaf format so that worksheets, tables, and charts can be removed to develop upgrading plans for a specific structure. This format also allows for the insertion of new data and techniques as they become available.

SSI 8012-7 Final Report
May 1981

Approved for public release;
Distribution unlimited

SHELTER UPGRADING MANUAL:
KEY WORKER SHELTERS

by

R.S. Tansley and R.D. Bernard

for

Federal Emergency Management Agency
Washington, D.C. 20472

Contract No. EMW-C-0153, Work Unit 1128A
Dr. Michael A. Pachuta, Project Officer

FEMA REVIEW NOTICE:

This report has been reviewed in the Federal Emergency Management Agency and approved for publication. Approval does not signify that the contents necessarily reflect the views and policies of the Federal Emergency Management Agency

Scientific Service, Inc.
517 East Bayshore, Redwood City, CA 94063

This report was prepared as an account of work sponsored by an agency of the United States Government. Neither the United States Government nor any agency thereof, nor any of their employees, contractors, subcontractors, or their employees, makes any warranty, express or implied, nor assumes any legal liability or responsibility for any third party's use or the results of such use of any information, apparatus, product or process disclosed in this report, nor represents that its use by such third party would not infringe privately owned rights.

Table of Contents

<u>Section</u>	<u>Page</u>
1 Introduction	1-1
2 Establishing the Number of Key Workers	2-1
3 Establishing Shelter Requirements	3-1
4 Survey and Upgrading of Existing Structures	4-1
5 Survey and Upgrading of Expedient Shelters	5-1
6 Shelter Closures and Entry Alternatives	6-1
7 Shelter Stocking	7-1
Appendix A: Upgrading Tables and Worksheets	A-1

SECTION 1- Introduction

Section 1 INTRODUCTION

This manual is one of a series being developed by Scientific Service, Inc., for the Federal Emergency Management Agency in support of the civil defense concept of crisis relocation planning. This concept presumes that a period of crisis buildup or international tension would precede any future major war. This period of crisis would allow time — a few days or weeks — to accomplish a number of activities to protect the civilian population and industry from attack. These activities include:

- 1) Evacuation of most of the population out of risk areas to host areas where only fallout and possibly low-level blast protection would be required.
- 2) Development of shelter in the risk area for a relatively small contingent of key workers who would remain behind to maintain necessary services — fire protection, communications, military production, etc.
- 3) Hardening and protection of industry.

This manual presents criteria for the selection and development of key worker shelters and is designed to be used by planners in risk areas. This first draft of a comprehensive shelter upgrading manual for key workers is far from complete, and users should be aware of its limitations. The FEMA directive was to develop shelters that would survive approximately 40 psi overpressure and to provide fallout protection equivalent to 3 ft of earth. The 40 psi criterion was a compromise between the desire to create shelter designs that could survive the very close-in weapon environment and the reality of what was practical when upgrading existing structures.

Essentially, the problem is to develop rational, safe measures for upgrading a structure, which was designed to support 150 to 250 psf, to support a blast loading of about 6,000 psf. Lack of adequate data has restricted the number of acceptable existing structures to a few basements with specific structural characteristics and has forced great dependency on expedient shelters. It is hoped that future test programs and the upcoming MILL RACE event will allow the inclusion of other structural types as shelters and increase the survival values.

The manual in its present form essentially outlines a training procedure for risk area planners and presents first a methodology for determining the number of key workers and for establishing shelter requirements, then a step-by-step process for surveying existing facilities for suitability as shelter spaces, locating other structures and facilities that can be used as expedient shelters, developing upgrading plans, and establishing stocking and management criteria.

SECTION 2 - Establish Number
of Key Workers

Section 2
ESTABLISHING THE NUMBER OF KEY WORKERS

Determining the minimum number of key workers is an essential first step in the planning process and will require close coordination with plant management. Obviously, the fewer key workers that are required the better, since this reduces the number of people at risk and simplifies the problem of providing shelters.

It is assumed that the risk area planner will be supplied a list of the essential facilities and service organizations for which shelters will have to be provided. It will be necessary, however, for the planner to assist in the process of determining the number of key workers required to maintain the operation of each facility. Most plant managers will have little appreciation of the problems involved in preparing for and surviving a nuclear war. Thus, it will require considerable education and guidance in each essential facility to assist management in deciding which functions are essential, which can be eliminated or relocated to the host area, and how many key workers will be needed.

It is relatively easy to identify certain functions in a facility as non-essential during the crisis period (building maintenance, sales and bookkeeping departments are examples). It is more difficult, however, to establish which parts of other operations are essential, and to determine the minimum number of key workers that will be required, since that determination will depend on the level of production to be maintained and the possibility that many operations can be simplified, eliminated, or moved to the host area.

The following examples, derived from in-plant surveys during the

development of an industrial protection manual,* illustrate the type of thinking and planning required in a potential essential industry that is located in the risk area.

Food Plant. — This plant is a medium size food processor. The plant manager's first evaluation of which processes and workers were essential included just about everything and everybody with the exception of the office staff. After a more careful explanation of crisis relocation and the possible needs and threat, the number of employees (about 50) and the number of processes (about 15) were reduced to a key worker staff of about five and only three processes. This was accomplished by eliminating many of the special handling and cosmetic processes normally performed. The plant owner's last evaluation was probably the most interesting, however: In a crisis, tomatoes, which are only a condiment, would not be necessary; his plant should probably be converted to provide more necessary products such as meat and milk.

Electrical Equipment Manufacturer. — A supplier of large utility transformers, this plant has 200 employees and over 2 acres of floor space. After a couple of hours of discussion, the plant engineer's recommendation was to halt production on the long leadtime (1 to 2 years) transformers and to concentrate on repair and rehabilitation of old transformers, which was a significant part of their operation. This could be accomplished with a very few skilled workers and a minimum of equipment; i.e., a cutting torch, a welder, and available raw materials.

Electrical Switch Manufacturer. — This plant was considered to be typical of many small manufacturing facilities, located throughout the United States, that will be necessary to supply military spare parts. An evaluation of this plant, which has 15 to 20 employees, indicated that the best alternative would be to evacuate the entire operation to the

* Zaccor, J.V., C. Wilton, and G. Shephard, Jr., "Industrial Hardening Demonstration," SSI Report No. 7828-8, prepared for Federal Emergency Management Agency, September 1980.

host area. The feasibility of this alternative was demonstrated when the plant subsequently relocated to a new site, and data were collected on the move: Four men completed the entire move in five working days, which included setting up the facility. Estimates were made that, in a crisis situation, eight men (i.e., half the plant personnel) could move the entire plant in one day and be operating again in two days.

In summary, some important factors for plant management and the planner to consider in determining the minimum number of key workers are:

- o Eliminate non-essential operations
- o Move part or all of the operation to the host area
- o Simplify operations — e.g., ship in bulk rather than package
- o Process only the most critical items.

SECTION 3 - Shelter
Requirements

Section 3
ESTABLISHING SHELTER REQUIREMENTS

In the event of a nuclear attack, key workers will need adequate protection from the initial effects — blast, initial radiation, and the thermal pulse — and from fallout, which begins to deposit approximately one-half hour after the blast.

Circumstances may require that two separate types of shelters be provided:

- o Short-term shelters that can be used for protection from the initial effects.
- o Long-term shelters that are of adequate size and equipped for an extended stay of two weeks or longer.

Long-term shelters are the most desirable and should be planned for if existing upgradable shelter spaces are available at the work site. Where such adequate close-in shelter space cannot be found, however, it will be necessary to provide short-term austere shelters from which personnel could evacuate either to the host area or to better long-term shelters located some distance away. At some large key facilities it may be necessary to provide both types of shelters.

Whatever the type of shelter, the following general criteria apply:

- o Shelters must be structurally capable of withstanding up to 40 psi and have sufficient radiation protection (equivalent to approximately 3 ft of earth at a density of 100 lb per cubic foot).

- o Shelters should be located far enough away from the expected target point so that the expected overpressure is less than 40 psi (1¼ miles from a one megaton weapon and 3¼ miles from a 20 megaton weapon).

- o Debris from collapsing buildings should not cover the shelter and prevent escape. This consideration essentially eliminates the use of basements of multi-story buildings and requires that shelters be located at least one building height away from any nearby structure.

- o Below ground shelters — unless they are water-tight — should not be located in high ground water areas, or in areas subject to flooding from surface runoff, ruptured tanks, or broken pipelines.

- o Shelters should not be located near hazardous or flammable materials.

- o Two exits should be provided, located as far apart as possible. Debris may block one exit, and an alternate escape exit should be provided.

- o Shelters should be of adequate size: For long-term shelters a minimum of 10 square feet of floor space and a minimum of 65 cubic feet of air volume should be provided per person. Means for ventilating the shelter area are also necessary. For short-term shelters the above recommendations are desirable, but not required.

- o Tools and equipment should be provided to aid in exiting the shelter, to remove debris and roadblocks during evacuation, and to rescue people from other shelters.

Specific criteria that apply to the type of shelter provided are as follows:

A fully equipped shelter should contain:

- o Sufficient life support supplies adequate for a minimum of two week stay-time. A detailed list is presented under the stocking and management section (Section 7).
- o Ventilation equipment adequate to supply at least 3 cubic feet per minute per person. (Larger air flows up to 40 cfm may be required in the hot humid areas of the country.)
- o An emergency power system
- o Radiation monitoring equipment
- o Communication equipment
- o Sleeping facilities
- o Firefighting equipment

A short-term, or austere, shelter should contain:

- o Escape vehicles, either in or near the shelter, protected to 40 psi.
- o Minimal life support supplies.

SECTION 4. Upgrade
Existing Structures

Section 4 SURVEY AND UPGRADING OF EXISTING STRUCTURES

The most desirable and economical shelters in terms of resources and manpower are those that can be found in existing structures at or close to the work site, and these should be surveyed first. Rather than one large shelter to house all of the key workers, two or more smaller shelters should be sought; this would greatly improve everyone's chances for survival, as one group could help another, should a problem arise.

The criteria described in the previous section essentially limit acceptable shelter spaces in existing structures to basement areas. (A few aboveground structures — bank vaults, radiation laboratories, etc. — may be suitable for use, and these should be treated on a case by case basis.) Because of blast-induced soil pressures, only basements with reinforced concrete walls are considered adequate. In most cases these will be found in structures that were for heavy industrial use (designed for 150 to 250 psf) under building code requirements that prevailed at the time.

With rare exceptions candidate shelters will need to be upgraded with regard to their blast protection. This generally will consist of reinforcing the floor slab over the basement (discussed in this section) and the provision of blastproof closures (discussed in Section 6). Shelters will also need to be equipped with the life support systems discussed in Section 7.

UPGRADING OF FLOOR SLABS

Seven reinforced concrete construction types have been found to be upgradable. The upgrading techniques shown in the following pages are

designed to upgrade the various construction types to 40 psi blast loadings.

The techniques are of two types depending on the type of construction:

- o Post shores
- o Post and beam supports

Spacing for both systems is based on supports at one-quarter of the span in both directions — width and length. For example if the span is 20 ft, the supports are to be placed 5 ft on centers; and if the span is 40 ft, the supports are to be placed 10 ft on centers. The space between shores is greater for longer spans; thus, fewer shores per shelter are required. Long span basement areas are expected to be few, however. If possible, areas with very close support shoring should be used only for short stay-time shelters.

The resources used in the upgrading procedures consist of:

- o Steel and wood posts
- o Steel beams

Wood beams cannot be used for upgrading to 40 psi because of stress limitations, which cause crushing of the beam fibers.

Upgrading procedures are presented for the following types of floor slabs:

<u>Two-Way Slabs</u>		<u>One-Way Slabs</u>	
Flat plate and flat slabs	p.4-4	One-way joist and one-way slab, beam and girder	p. 4-10
Waffle slabs	p.4-6	Double tee	p. 4-12
Slab and girder	p.4-8	Hollow-core	p. 4-14
		One-way slab and girder	p. 4-16

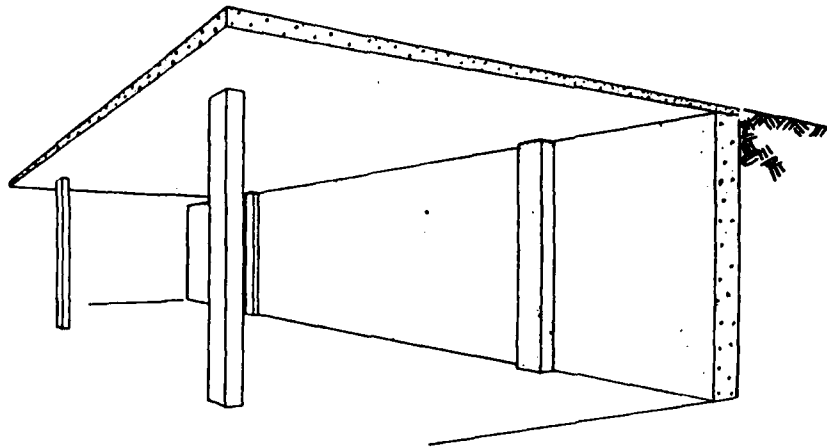

Flat Plate and Flat Slab

Characteristics and Construction Details

Concrete slabs are 8 inches to 12 inches thick without other detailed engineering or construction features.

Columns are concrete and are constructed integrally with the floor slabs in a variety of ways as shown below. Columns may be round or square, and details refer to interior columns and columns constructed adjacent to a concrete wall.

Drop panels are usually 2 to 5 inches thick, and column capitals vary in height.

Spans between columns normally vary from 16 to 30 feet.

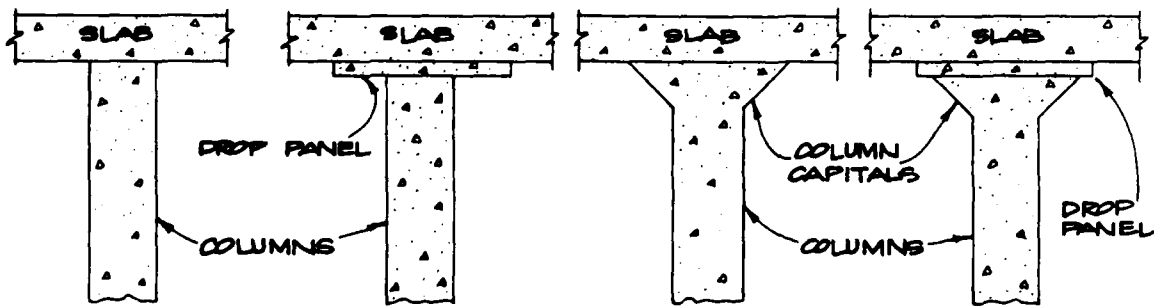

FLAT PLATE AND FLAT SLAB UPGRADING

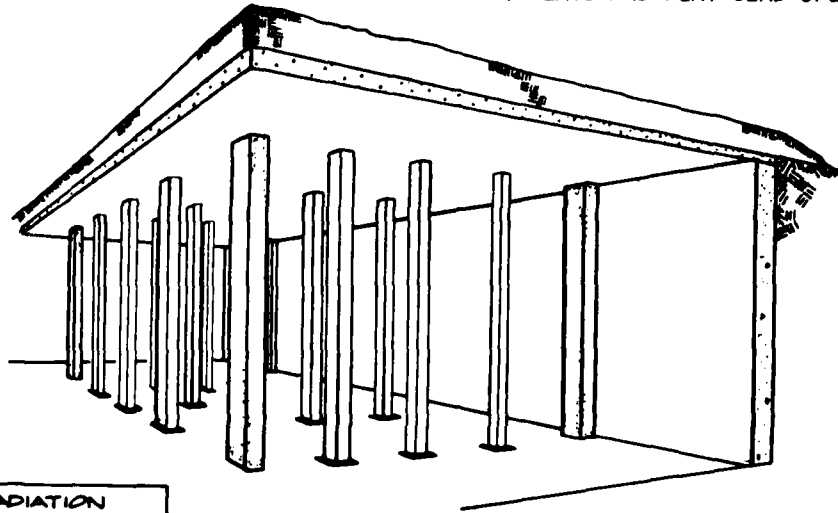

RADIATION	
P _F	DEPTH
1000	2.0

Shoring

The recommended method for shoring flat plate and flat slabs is to use post shores, as shown in the sketch above. For shore classification, see spacing chart below, and for types of shores refer to pages A-3 to A-5. Maximum unshored distance should not exceed one-quarter of the span.

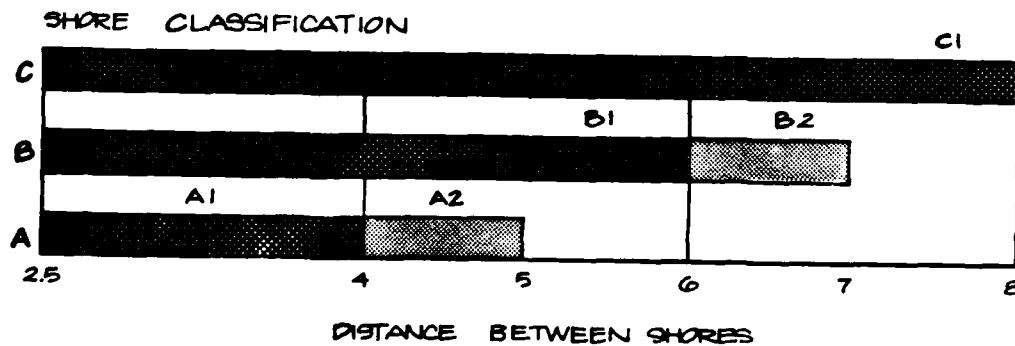

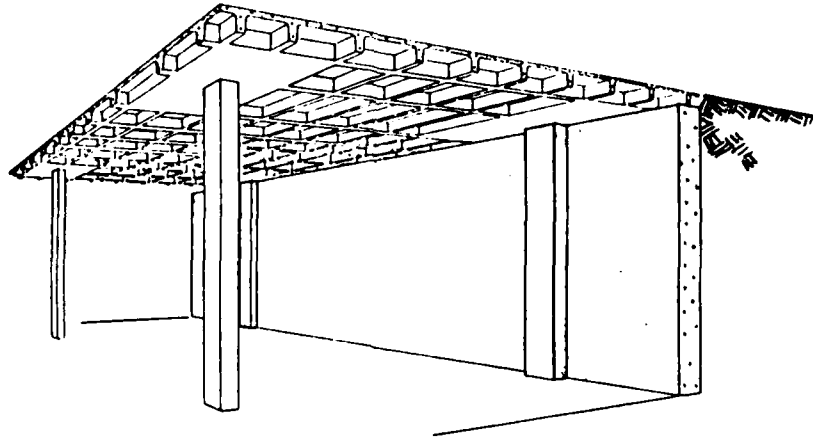

Waffle Slab

Characteristics and Construction Details

Concrete deck and ribs are cast as one unit. The industry standard waffle forms are 19 inches square and 30 inches square. Top slab thickness is usually 3 inches or 4½ inches.

Ribs are 5 inches thick for 19-inch waffle forms, and vary in depth from 6 to 12 inches.

Ribs are 6 inches thick for 30-inch waffle forms, and vary in depth from 8 to 20 inches.

A non-waffled section is constructed around each column.

Columns are concrete and are constructed integrally with the waffle slab. Typical details are shown below. Spans between columns normally vary from 15 to 36 feet.

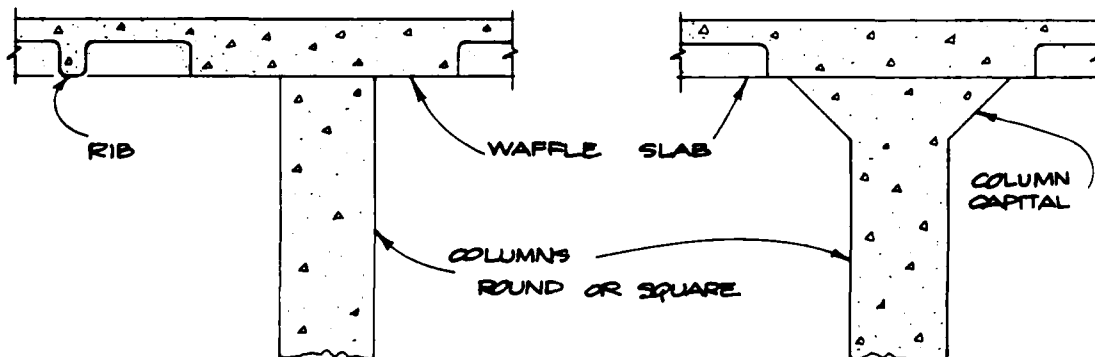

WAFFLE SLAB UPGRADING

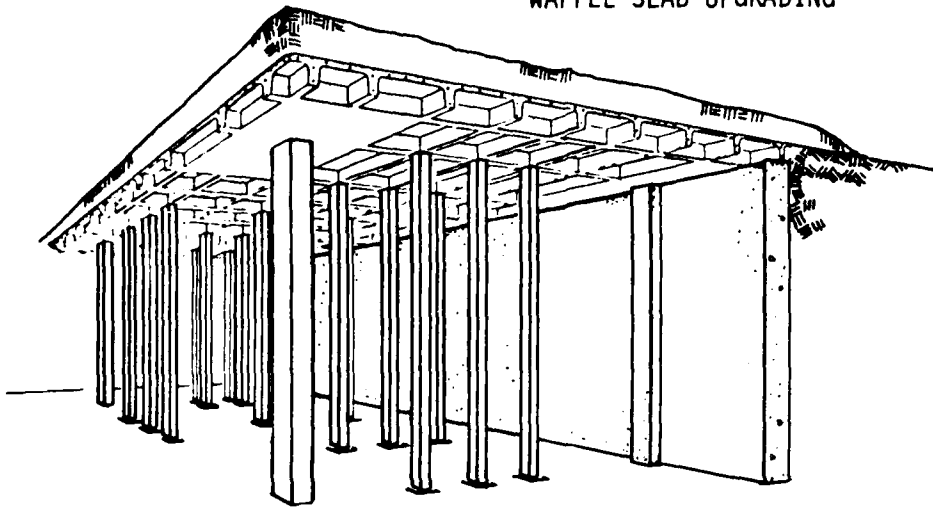

RADIATION	
PF	DEPTH
1000	2.5

Shoring

The recommended method for shoring waffle slabs is to use post shores, as shown in the sketch above. For shore spacing, the posts must be placed at the intersection of the waffle ribs. Thus, for 19-inch waffles, the posts will be at multiples of 2 feet, and for 30-inch waffles, the posts will be at multiples of 3 feet. For shore classification, see spacing chart below, and for types of shores, refer to pages A-3 to A-5. Maximum unshored distance should not exceed 1/4 the span. More shores may be required for the waffle slab because of post shore location restrictions.

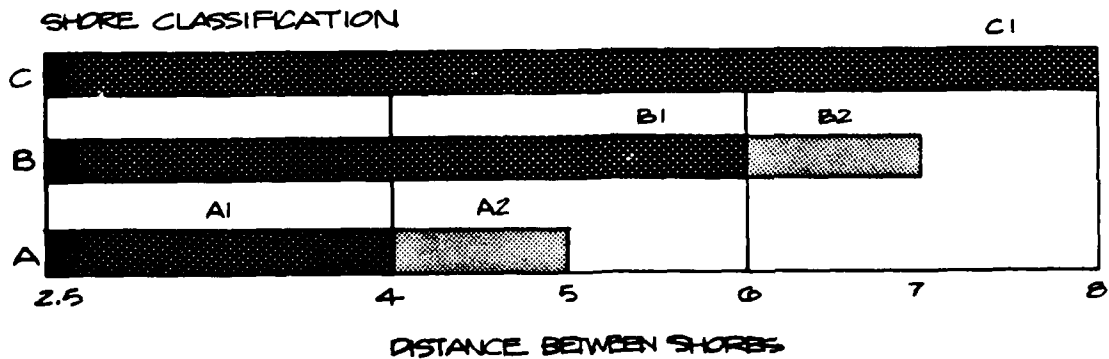

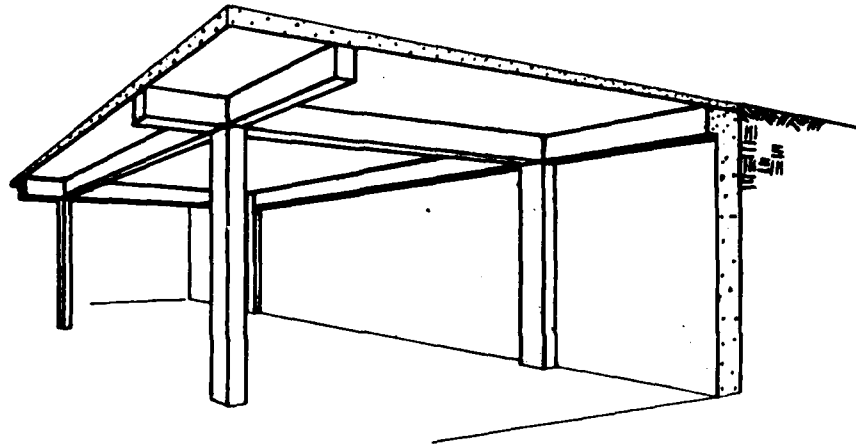

Two - Way Slab & Girder

Characteristics and Construction Details

Concrete slabs are 8 to 12 inches thick, and girders are cast with the slab.

Columns are concrete, and are constructed integrally with the girders.

Columns are generally square or rectangular.

Girders are usually 12 inches wide or more and may be up to 36 inches deep in heavy, long-span structures.

Span between supports normally varies from 16 to 30 feet.

TWO-WAY SLAB & GIRDER UPGRADING

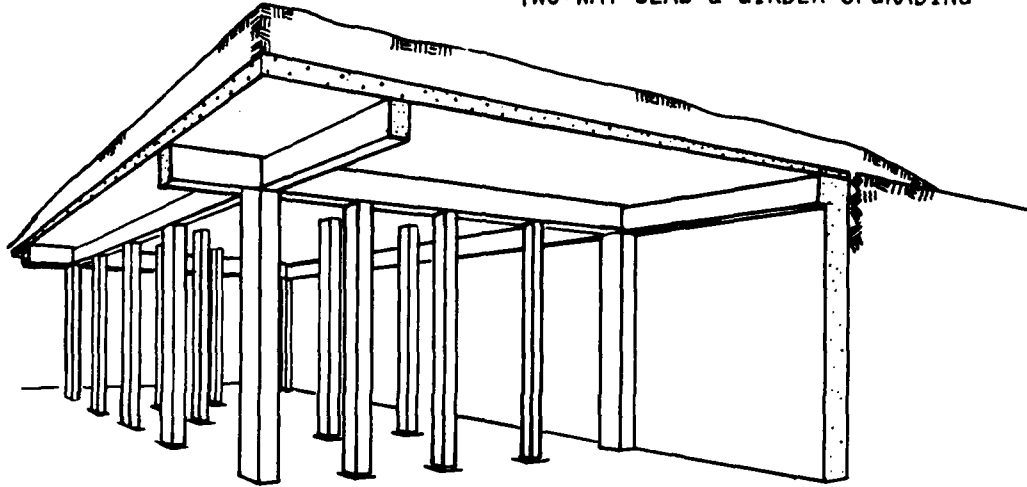

RADIATION	
PF	DEPTH
1000	2.0

Shoring

The recommended method for shoring two-way slab and girder is to use post shores, as shown in the sketch above. Two lengths of shores must be provided for shoring the beams and the slab, respectively.

For shore classification see spacing chart below, and for types of shores, refer to pages A-3 to A-5.

Maximum unshored distance should not exceed 1/4 the span.

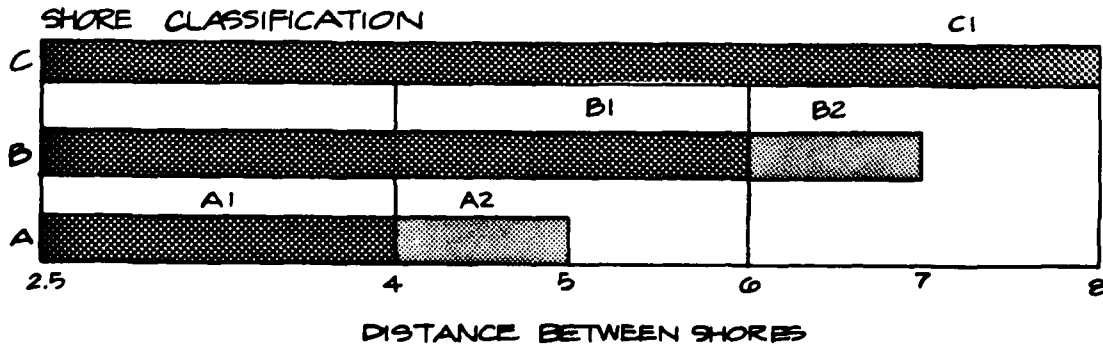

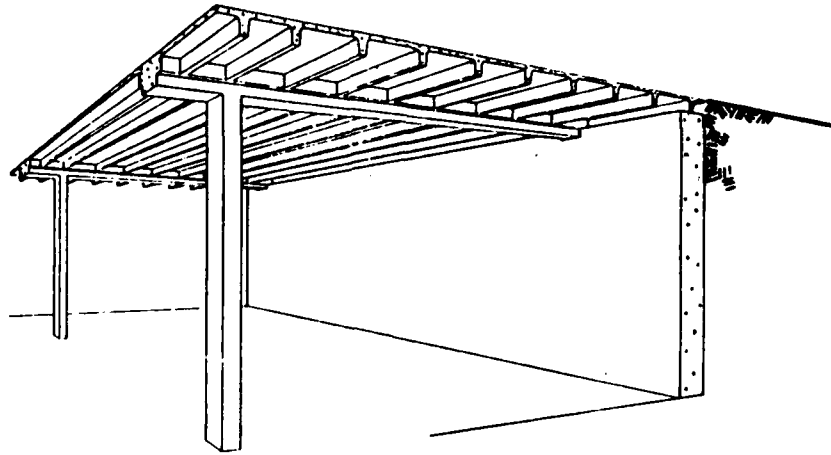

One-Way Joist & One-Way Slab, Beam & Girder

Characteristics and Construction Details

Concrete slabs are poured monolithically with joist ribs or beams, and girders.

Slabs for one-way joists are $3\frac{1}{2}$ to 4 inches thick. Joist ribs vary from 5 to 7 inches thick, from 10 to 20 inches deep, and are tapered. Spacings between ribs are usually 20 inches or 30 inches. Span length varies from 16 to 26 feet.

Slabs used in slab, beam and girder construction are generally 6 inches and thicker. Beams are generally not less than 10 inches wide, and girders not less than 12 inches wide. Depth of beams and girders vary and generally are not greater than 30 inches. Spans vary from 20 to 36 feet.

Columns are generally rigidly tied to girders and can be rectangular or square.

ONE-WAY JOIST & ONE-WAY SLAB, BEAM
AND GIRDER UPGRADING

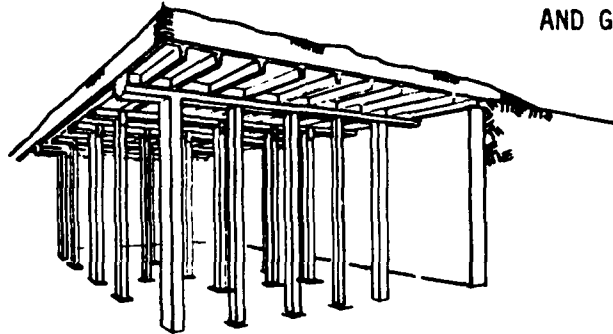

RADIATION	
Pf	DEPTH
1000	2.5

Shoring

The recommended method for shoring one-way joist and one-way slab, beam and girder is to use post and beam shores. It should be noted that posts and beam shores are to be placed under the joist and beam portions of the basement area. Post shores must be used under the main girder members.

For shore classification, see spacing chart below, and for types of shores, refer to pages A-3 to A-6.

Maximum unshored distance should not exceed 1/4 the span.

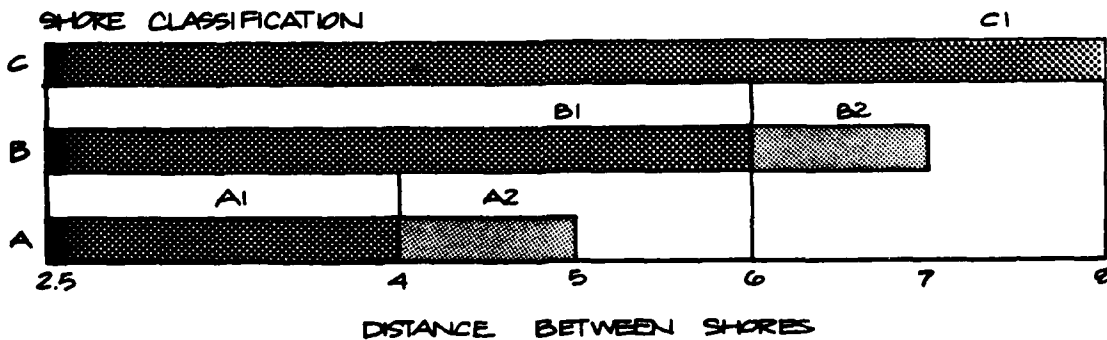

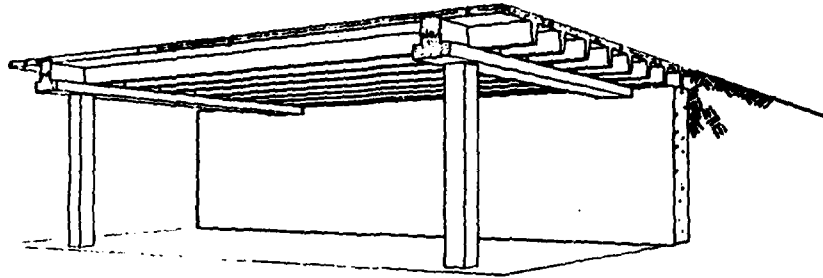

Double Tee

Characteristics and Construction Details

Concrete double tee construction are precast units, transported and erected at the site.

Girder beam supports are often inverted tee beams set in place, or cast with the columns.

Slab thickness usually is not less than 4 inches. Thicker slabs occur with deep, widely spaced tee stems.

Stems normally range from 16 to 32 inches deep, and double tee spans range from 18 to 30 feet.

Columns are usually square or rectangular and are usually tied to the girders.

DOUBLE TEE UPGRADING

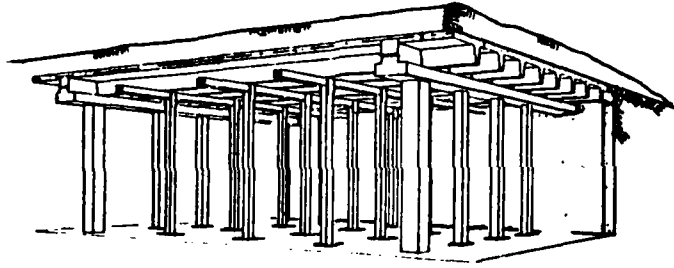

RADIATION	
PF	DEPTH
1000	2.5

Shoring

The recommended method for shoring double tee concrete construction is to use post and beam shores, with post shores under the supporting girders.

For shore classification, see spacing chart below, and for types of shores, refer to pages A-3 to A-6.

Maximum unshored distance should not exceed $1/4$ the span.

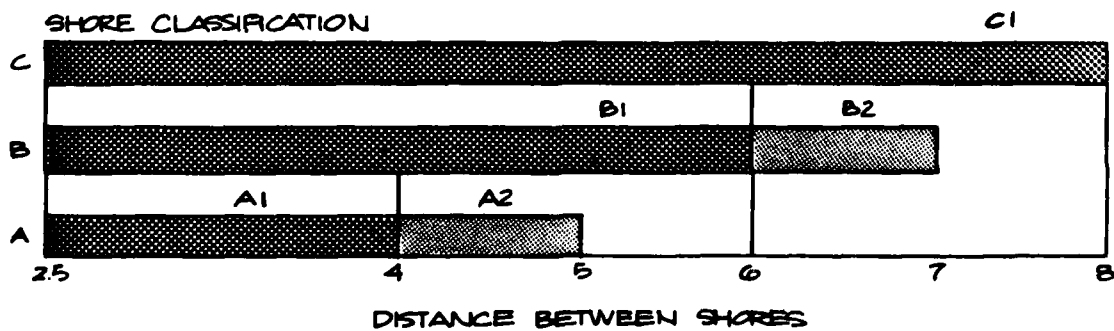

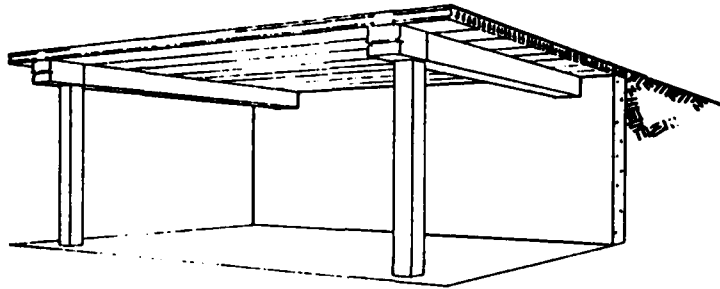

Concrete Hollow - Core

Characteristics and Construction Details

Concrete hollow-core construction is fabricated as precast slab units, with reinforcing in the longitudinal direction only. Individual slabs are placed side by side, and the deck is usually surfaced with a thin layer of concrete. Slab thickness is usually 8 to 10 inches.

The slabs are supported on girders and columns. The girders may be precast or cast-in-place. Columns may also be precast or cast-in-place.

Hollow-core spans normally range from 18 to 28 feet.

CONCRETE HOLLOW-CORE UPGRADING

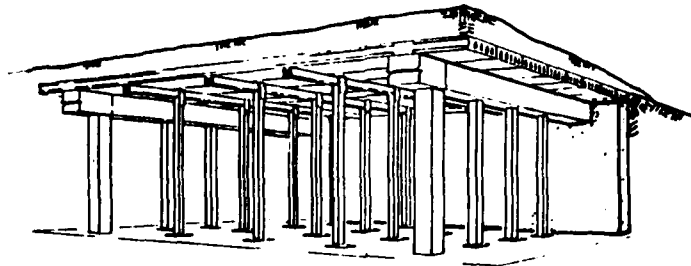

RADIATION	
PF	DEPTH
1000	2.5

Shoring

The recommended method for shoring hollow-core construction is to use post and beam shores under the slabs, and post construction under the supporting girders.

For shore classification, see chart below, and for types of shores, refer to pages A-3 to A-6.

Maximum unshored distance should not exceed 1/4 the span.

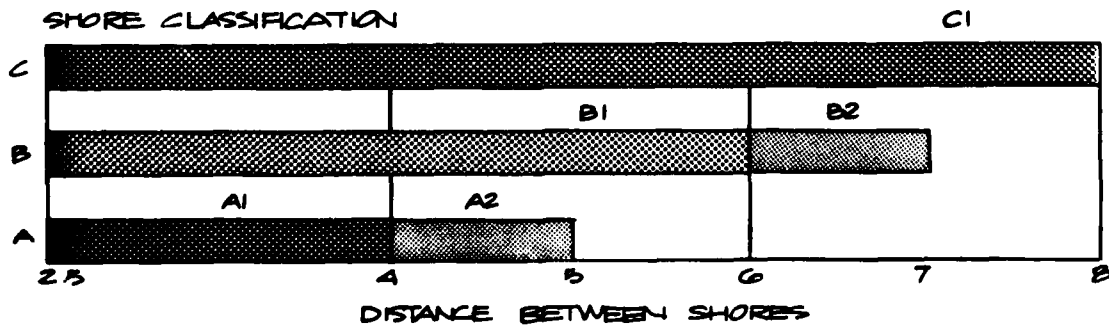

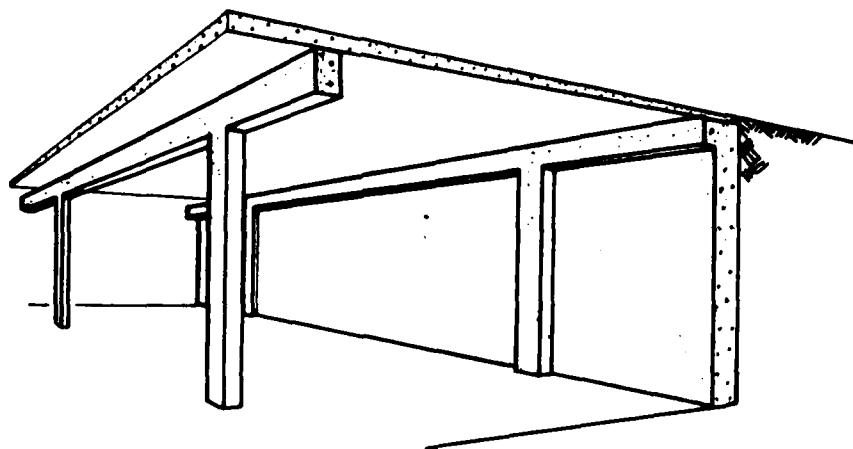

One-Way Slab and Girder

Characteristics and Construction Details

Concrete slabs are 8 to 12 inches thick, and girders are cast with the slab.

Columns are concrete and are constructed integrally with the girders. Columns are generally square or rectangular.

Girders are normally 12 inches wide or greater, and may be up to 36 inches deep in heavy, long-span structures.

Spans between supports along the girders normally vary from 20 to 30 feet. The width between girders is usually one-half the span length or less.

ONE-WAY SLAB AND GIRDER UPGRADING

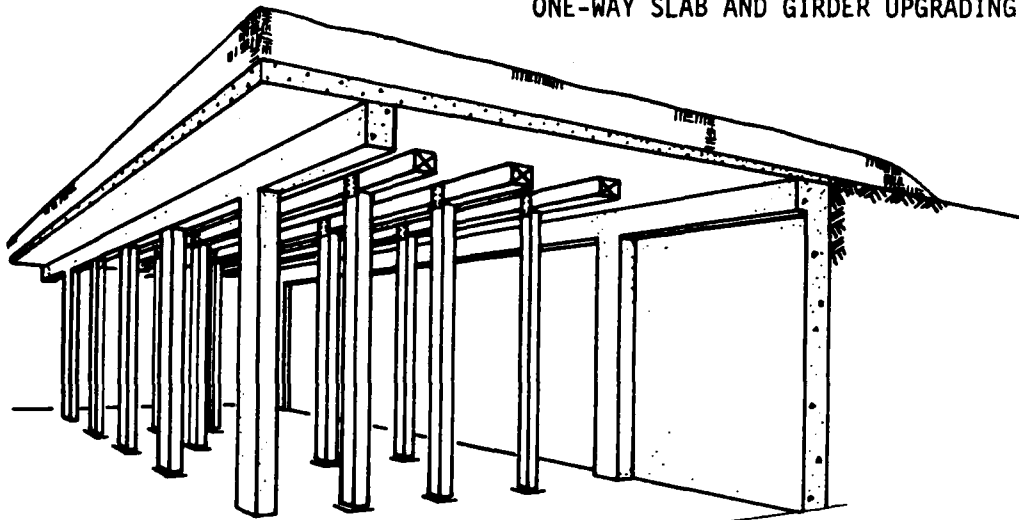

RADIATION	
PF	DEPTH
1000	2.0

Shoring

The recommended method for shoring one-way slab and girder is to use post and beam shores under the slab, as shown in the sketch above, and post shores under the girder. Two lengths of shores must be provided for shoring the beams.

For shore classification, see spacing chart below, and for types of shores, refer to pages A-3 to A-6.

Maximum unshored distance should not exceed $1/4$ the span.

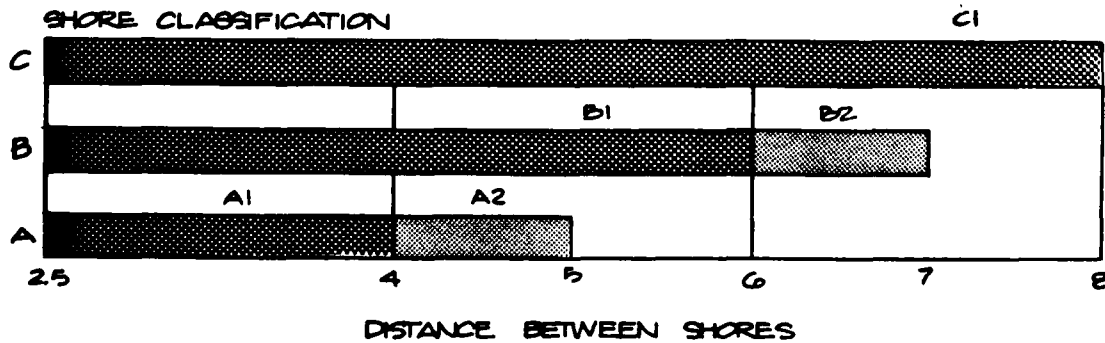

SECTION 5: Upgrade
Expedient Shelters

Section 5
SURVEY AND UPGRADING OF EXPEDIENT SHELTERS

Because of the limited number of existing structures that have been found to be upgradable, it will be necessary in many cases to use expedient shelters. There are many options that should be considered, including adapting onsite facilities such as tanks, storm drains, utility vaults, or alternatively obtaining a structure that can be used as a buried shelter. These structures that can be buried and used as shelters include railroad cars, tanks, or specially designed shelters.

Expedient shelter options discussed are as follows:

Buried tanks	page 5-2
Railroad cars	page 5-3 to 5-8
Storm drain systems	page 5-9 to 5-12
Other shelter types	page 5-14 to 5-16

Two expedient shelter worksheets (Worksheets 7 and 8) are provided in Appendix A as an aid for implementing expedient shelters. These worksheets are designed to assist the industry planner in shelter selection and upgrading.

The shelter options discussed herein are only a few of the potential possibilities for key worker shelters. Each plant superintendent and/or planner should survey his plant and immediate area for the best choices. The formation of mutual aid pacts with other nearby essential industries to jointly develop key worker shelters should also be considered.

EXPEDIENT SHELTER FACT SHEET

BURIED TANKS

Buried tanks provide ideal shelters and, dependent upon size, can be used for both long and short stay-times.

- (1) Pressure vessel type tanks, such as newly manufactured liquid propane or LNG type tanks, do not require upgrading.
- (2) Many other types (non-pressure) can be easily upgraded. Detailed upgrading schemes have not yet been developed.

Limitations

- (1) Do not use tanks that have been used previously for fuel storage, toxic chemicals, or other hazardous materials.
- (2) Do not bury tanks in areas where high ground water is present, as the tanks may rise out of the ground owing to fluid uplift pressures.
- (3) The number of people that can be sheltered in pressure vessels in most instances will not exceed ten.

Typical Installation (Any Buried Tank)

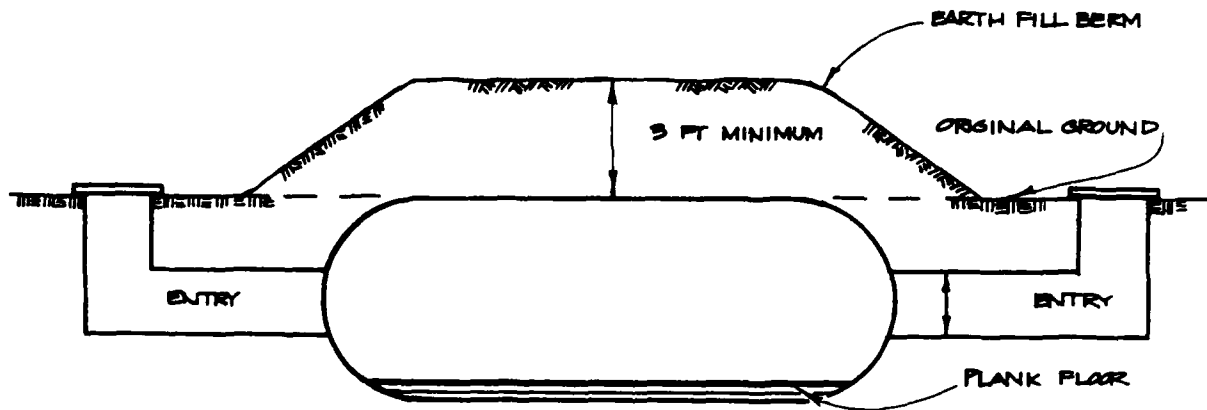

Note: Entry can be fabricated using 30-inch diameter corrugated metal, concrete pipe, or wood framing. See section on closures.

EXPEDIENT SHELTER FACT SHEET

RAILROAD CARS

Certain types of railroad cars can provide ideal shelters without upgrading for 20 to 30 people for long as well as short stay-times. The railroad car options discussed are limited to those fabricated of structural steel components, as described, and would not ordinarily require upgrading:

Rail tank cars

Hopper cars, both open and closed

Gondola type cars

Notes

- (1) All cars would have their undercarriages, couplers, and miscellaneous non-essential frame materials removed.
- (2) Rail tank cars have access hatches on the top. Thus, the cars could be buried upright or on their sides.
- (3) Closed hopper cars have two compartments, and thus, two separate shelters can be provided from one car. Cars could be buried upright or on their sides.
- (4) Open hopper cars can be buried upside down, and the hopper gate modified as a shelter entrance.
- (5) Gondolas can be buried upside down, and access may then be provided through the side walls.
- (6) Heavy crane or other lifting equipment is required to place cars in excavation.

Advantages of Implementing Railcars

- (1) Railcar types suggested for expedient shelters are all constructed of steel sheet plate with heavy steel frames, hatches, and reinforcing.
- (2) Railcar bodies are readily available from car dismantler companies.

TYPICAL RAILCAR ANNUAL RETIREMENT

Type of Car	Total No. of Cars Retired Annually	10% of Car Bodies Usable Without Repair	20% of Car Bodies Estimated Repairable	Total Potential Car Bodies Usable
Tanks	128	13	26	39
Hopper (closed)	11,382	1,138	2,276	3,414
Hopper (open)	23,271	2,327	4,654	6,981
Gondolas	12,559	1,256	2,512	3,768
TOTALS	47,340	4,734	9,468	14,202

Details of railcars buried as expedient shelters are shown on the following pages.

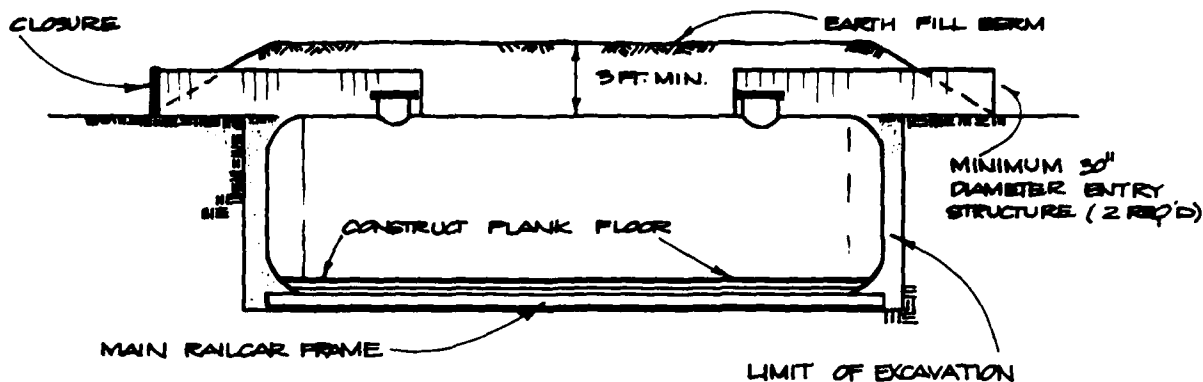

Typical Buried Railroad Tank Car

- Notes:
- (1) Railcar undercarriage and frame are removed from tank to the extent possible; otherwise bury with frame components.
 - (2) Interior floor may be constructed with plywood and 2-inch dimension lumber for framing.
 - (3) Access to car hatches may be fabricated with 30-inch corrugated metal, including elbow at hatch. A wood-framed entry may also be used. It may be necessary to remove hatches, to provide access.
 - (4) Entry structure can also be used for ventilation.
 - (5) Temporary closures are required for radiation protection.
 - (6) Tank must be steam cleaned prior to burial. DO NOT USE tank cars that were previously used for fuel storage, toxic chemicals, or other hazardous materials.

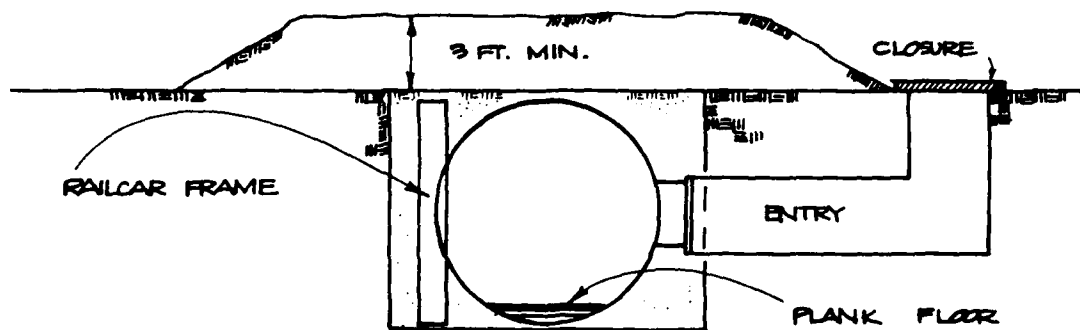

Typical Buried Railroad Tank Car - Alternate Entry Configuration (On Side)

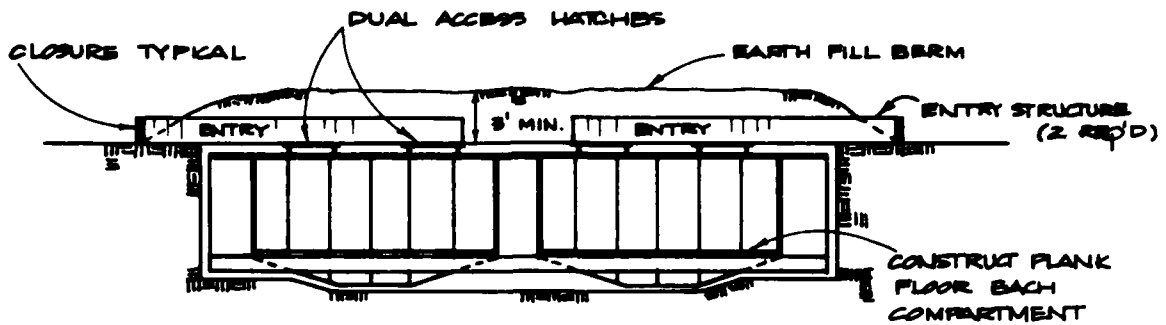

Typical Buried Closed Hopper Car

- Notes:
- (1) Railcar undercarriage and miscellaneous frame components to be removed prior to burial.
 - (2) Interior of car must have floor constructed over sloped hopper bottoms. Area below floor to provide shelter supply storage.
 - (3) Access to hatches to be fabricated of 30-inch metal pipe or wood framed. Double entry to compartment hatches for ventilation is recommended. Alternate hatch can be provided through side of car.
 - (4) Temporary closures are required for radiation protection.
 - (5) Hoppers to be cleaned prior to burial.

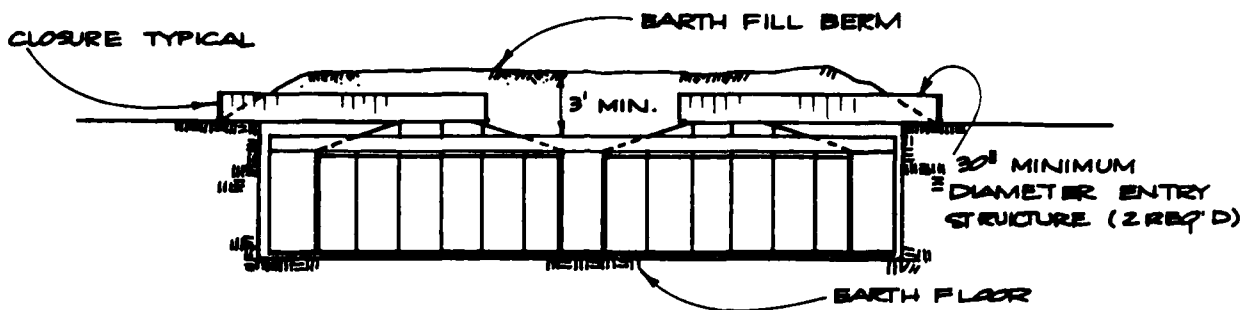

Typical Buried Open Hopper Car (Upside Down)

- Notes:
- (1) Railcar undercarriage and miscellaneous frame components are removed prior to burial.
 - (2) Burial is upside down; earth floor is proposed; wood or other floor optional.
 - (3) Access is through hopper bottoms, or alternatively, through side of car.
 - (4) Temporary closures on entry are required for radiation protection.
 - (5) Hoppers to be cleaned prior to burial.

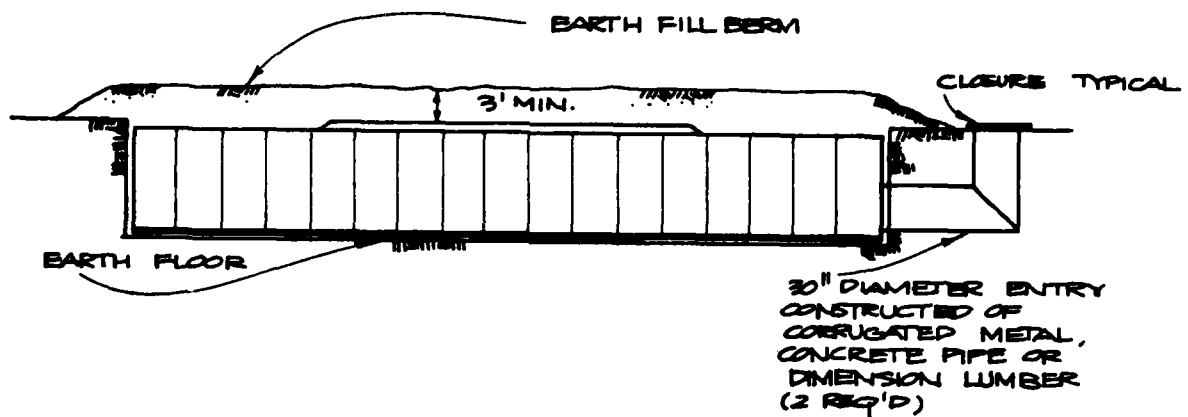

Typical Buried Gondola Car - Upside Down

- Notes:
- (1) Railcar undercarriage and miscellaneous frame components are removed prior to burial.
 - (2) Burial is upside down; earth floor is proposed. Wood or other floor is optional.
 - (3) Access is proposed through end or sides of car.
 - (4) Temporary closures on entry are required for radiation protection.
 - (5) Car interior to be steam cleaned prior to burial.

EXPEDIENT SHELTER FACT SHEET

STORM DRAINAGE SYSTEMS

Major storm drainage facilities and their components can provide shelter in key worker areas for long and short stay-times. Two components of a typical drainage system are analyzed for shelter purposes:

- o Storm drain manholes (short stay-time)
- o Major conduits — 5 feet and larger (long stay-time)

Notes:

- (1) Manholes should be a minimum of 4 feet in diameter and 6 feet deep.
- (2) Manholes are often located in high volume street traffic areas and therefore, access to them may not be available in these locations. Manholes located in street medians, parking, or low-traffic areas may be more easily implemented.
- (3) Large closures are necessary at conduit ends to provide blast protection, and these closures probably cannot be fabricated in less than 72 hours without some preplanning.
- (4) All open drain inlets must be sandbagged to provide blast protection.
- (5) Some storm drainage conduits may have considerable depth of flow or be located in areas subject to tidal action and thus, would not be available for shelters.
- (6) Utilizing storm drain conduits with a minimum depth of water flow may necessitate construction of false floor systems. (See sketch of box culvert type of conduit.)

Advantages of Using Storm Drain System Components as Expedient Shelters

Manholes (short stay-time):

- (1) Storm drain manholes are numerous. On any major drainage system they are located from 500 to 1,000 feet apart.
- (2) They require no upgrading and are easily adapted to use as as short-stay-time, one- or two-man shelters, with addition of a temporary wood floor and modifications to manhole lid closures (see page 6-5).
- (3) Special ventilation equipment is not required, as ventilation naturally occurs through drain pipes at base of manhole.
- (4) If storm drains are not available near the key industry, manhole sections, as shown in Figure 5-3, may be obtained from manufacturers, and one- or two-man shelters can be buried at the key worker site. For small key industries with fewer than five key workers, this may be a viable option.

Major Conduits — 5 feet and Larger (long stay-time):

- (1) No radiation or fallout shielding is necessary because of depth of burial.
- (2) Ventilation equipment is not needed, as the systems have natural ventilation at all inlet locations. Fabrication of blast resistant closures must be implemented also.
- (3) Long drain systems are large enough to provide shelter for more than one industry or industrial plant.

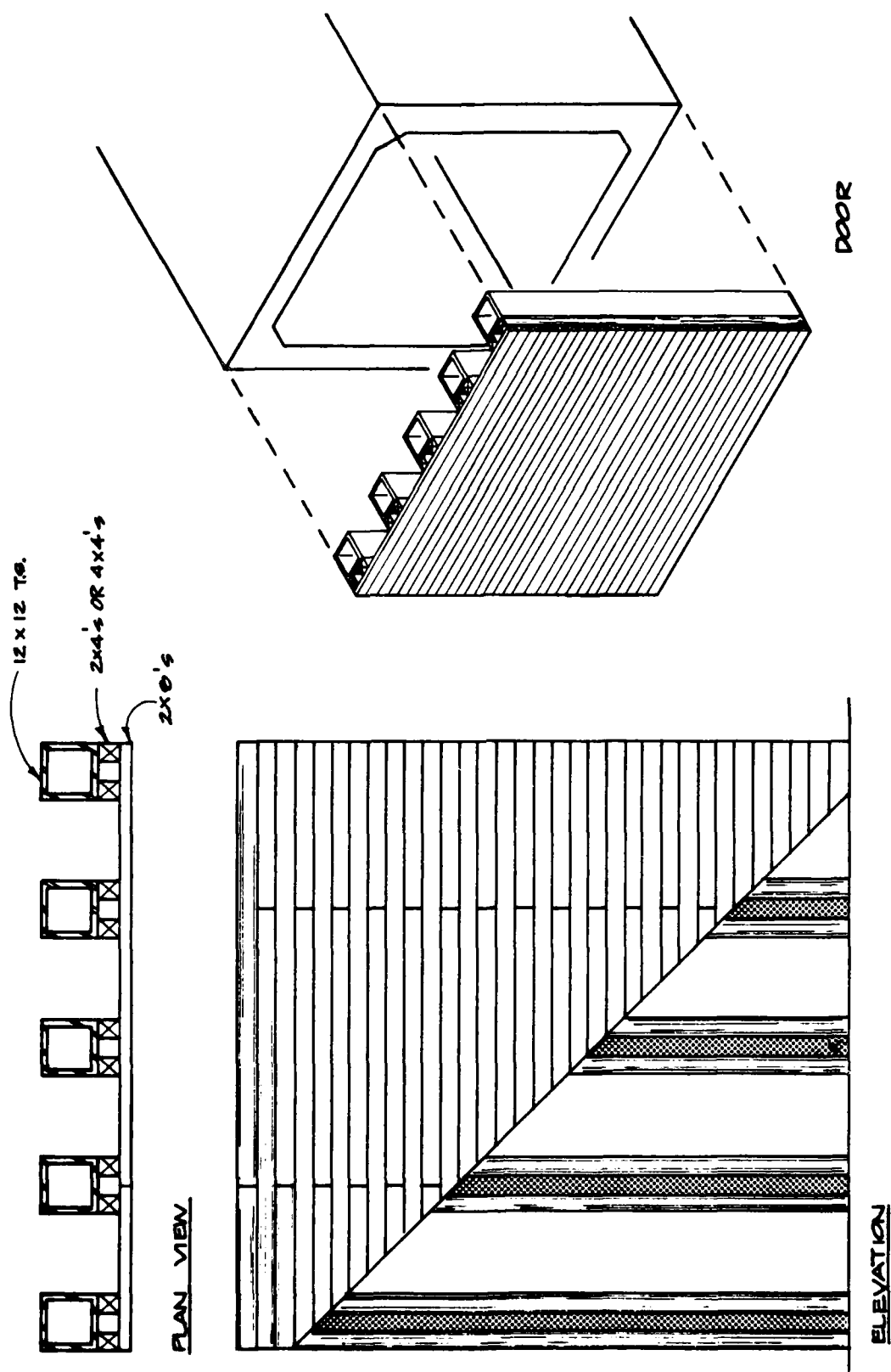

Fig. 5-1. Typical Closure for a 10 ft by 10 ft Box Culvert For 40 psi.

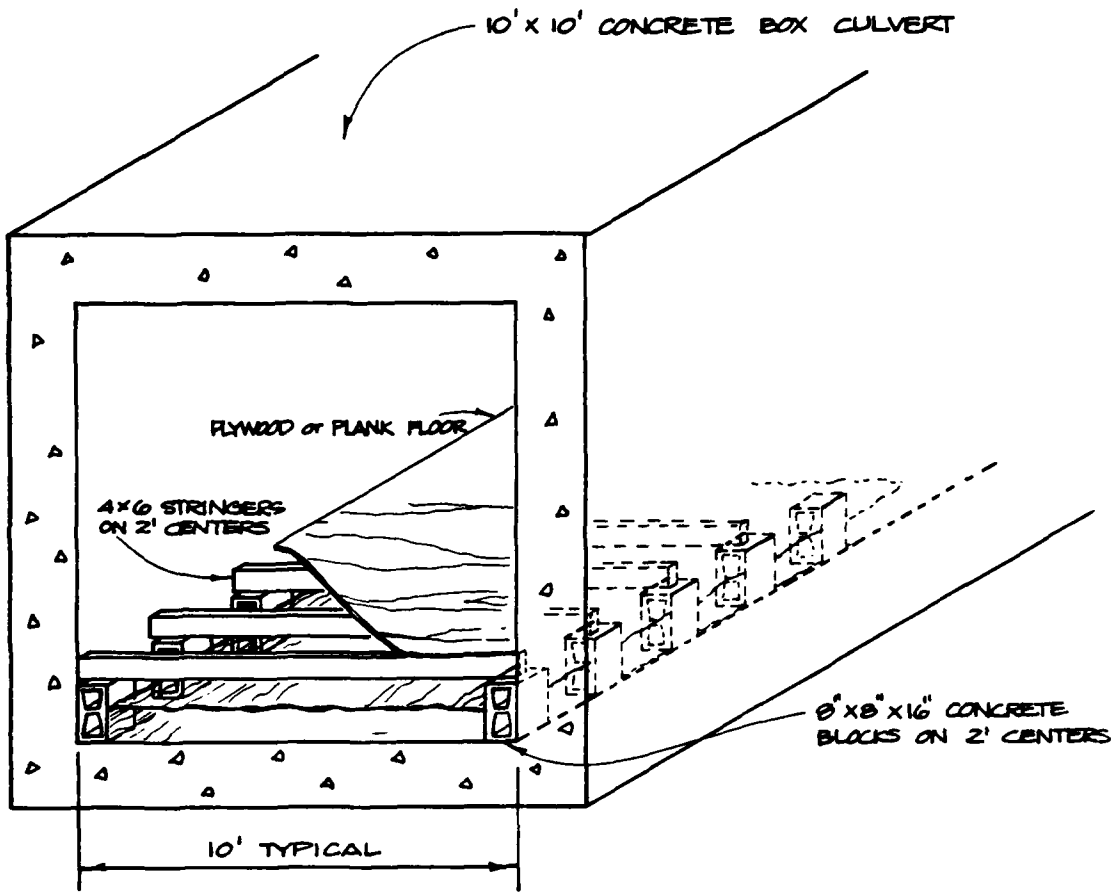

Fig. 5-2. Box Culvert Key Worker Shelter With Low-Flow False Floor.

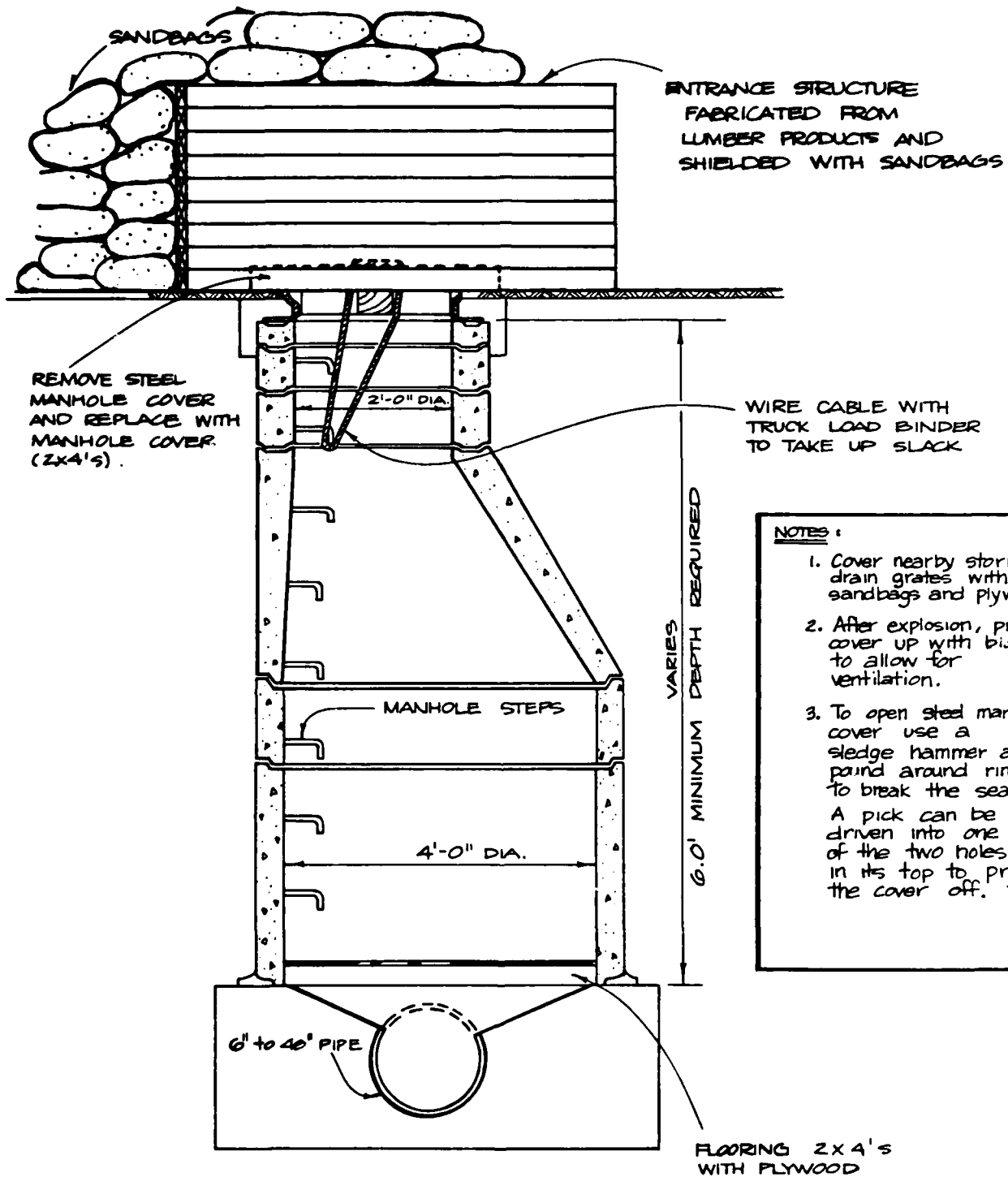

Fig. 5-3. Key Worker Shelter in Storm Manhole.

EXPEDIENT SHELTER FACT SHEET
CONCRETE UTILITY VAULTS

The adaptation of prefabricated underground utility vaults (the types used by telephone and electrical utilities) for key worker shelters is recommended as a valuable, practical, and easily implemented shelter option. The implementation of precast utility vault components for a shelter has been previously tested, and placement of a six-man vault and entrance structure, including covering the vault with earth radiation protection, required less than 10 hours using three men and heavy equipment.

Figures 5-4 and 5-5 show the burial of a utility vault shelter and the upgrading of various components.

C.E.M.O. MARK II SHELTER

Previous experiments have been conducted to determine the use of a corrugated thin-walled fiberglass type cylinder structure for shelter purposes in the Dial Pack tests in 1971. The shelter survived a 40 psi blast with only minor structural damage, which was attributed to poor backfill operations. All equipment and supplies in the shelter were usable.

Figure 5-6 shows the C.E.M.O. Mark II shelter.

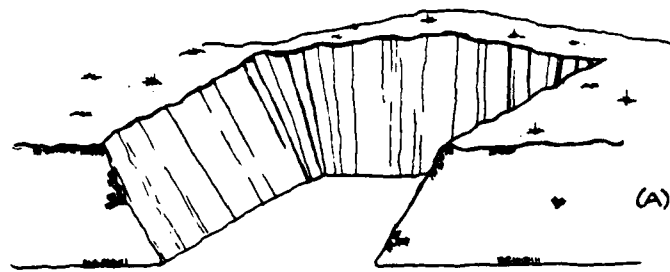

(A) EXCAVATION FOR UTILITY VAULT.

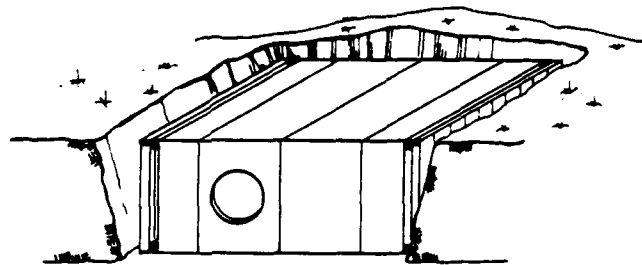

(B) VAULT IN PLACE PRIOR TO BACKFILLING.

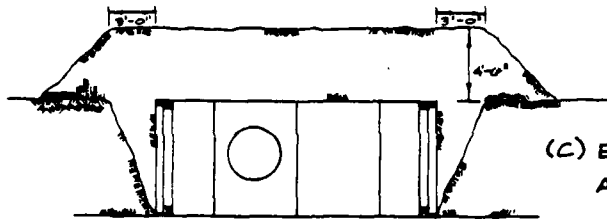

(C) END VIEW SHOWING BACKFILL AND RADIATION PROTECTION BERM.

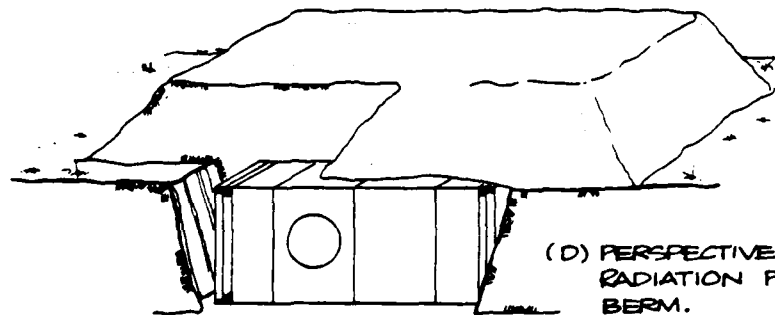

(D) PERSPECTIVE VIEW OF RADIATION PROTECTION BERM.

Fig. 5-4. Utility Vault Shelter.

ASSEMBLY DRAWING

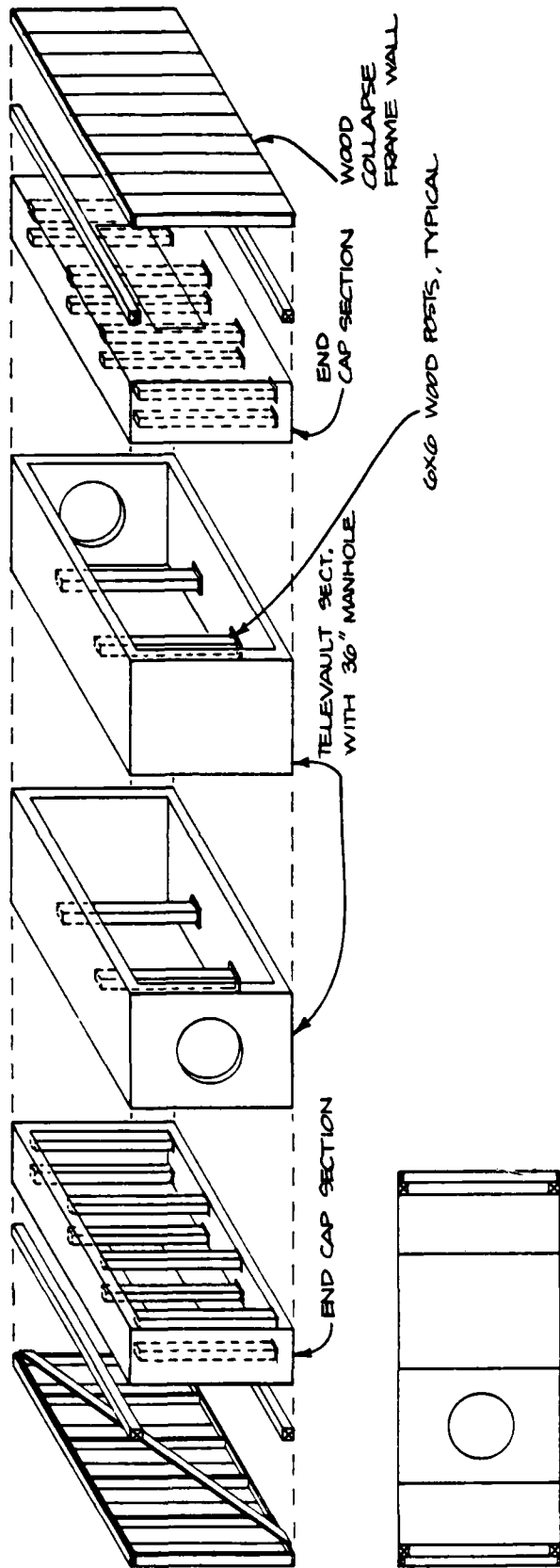

Fig. 5-5. Utility Vault Shelter Components, Depicting Upgrading Methods to Provide 40 psi Overpressure Protection.

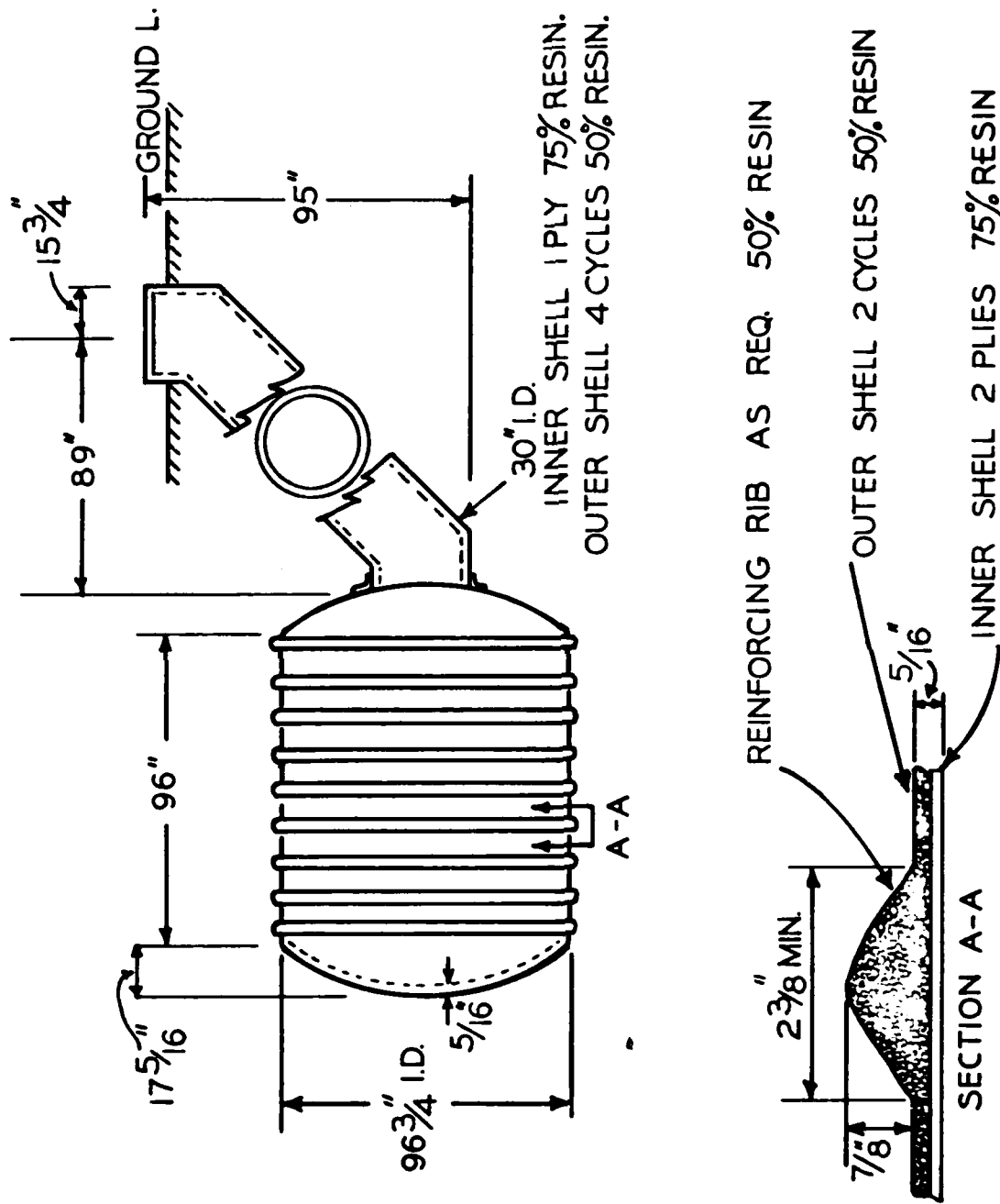

Fig. 5-6. C.E.M.O. Mark II Shelter Details. (Event Dial Pack Symposium Report, Vol. II, Published by The Defence Research Board of Canada, March 1971)

SECTION 6 - Closure and
Entry Alternatives

Section 6
SHELTER CLOSURES AND ENTRY ALTERNATIVES

Shelter entry structures and closures are key elements in the development of 40 psi blast-resistant key worker shelter spaces. For the upgrading of existing basement areas, the main concern is with blast-resistant closures for existing entryways and other existing openings. Expedient shelters require, in addition, consideration of shelter entry structures.

SHELTER ENTRY STRUCTURES

The use of expedient shelters requires fabrication of novel structures and efficient use of available resources. A typical wood construction entry structure is shown in Figure 6-1 and a suitable closure is shown in Figure 6-2.

As an alternative to wood construction, concrete pipe or corrugated metal pipe entry structures may also be fabricated. Figure 6-3 shows such a typical structure, and Figure 6-4 is a suitable closure for a circular entry structure.

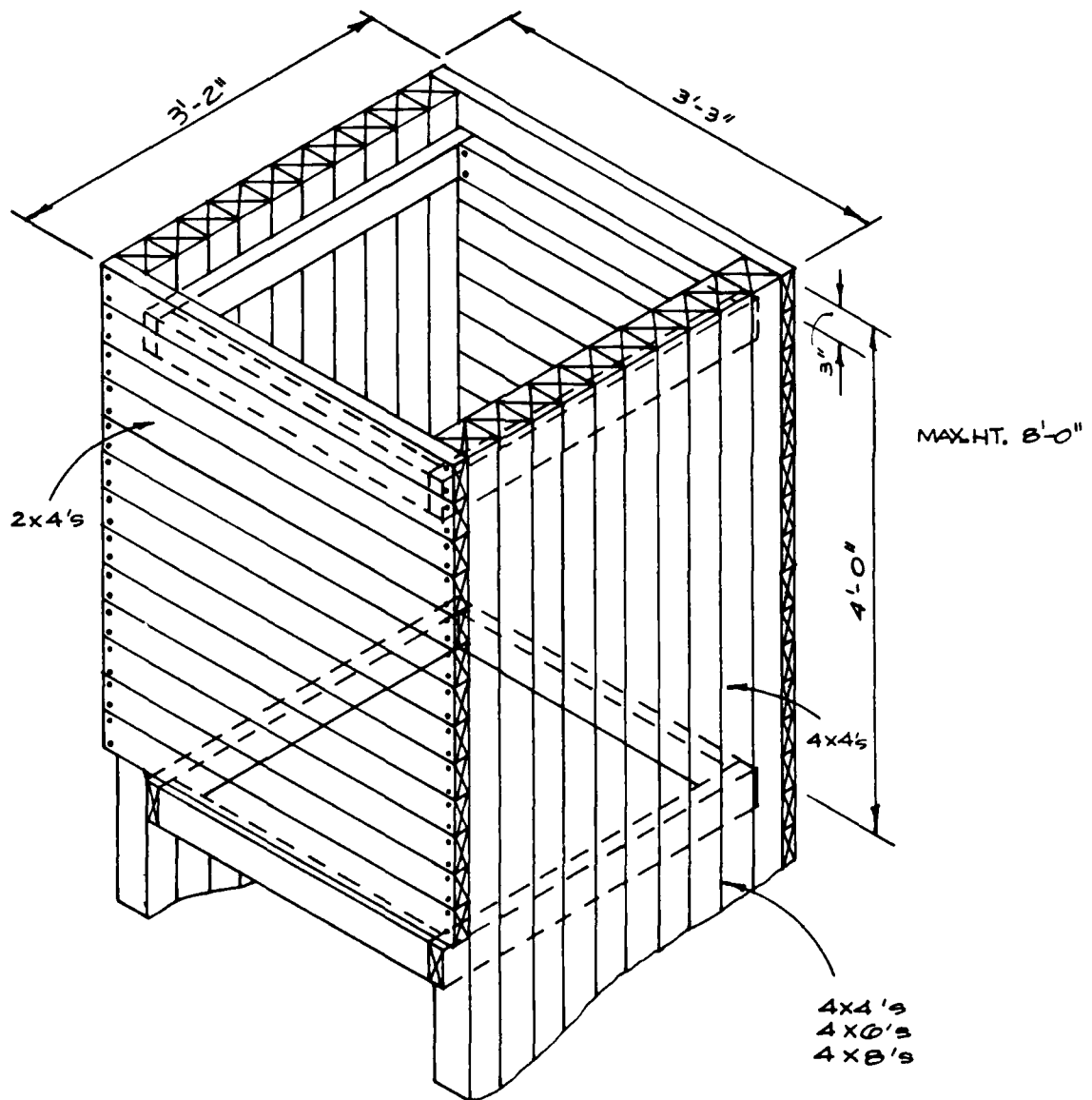

Fig. 6-1. 40 psi Entrance Structure to Key Worker Shelter (Wood Construction).

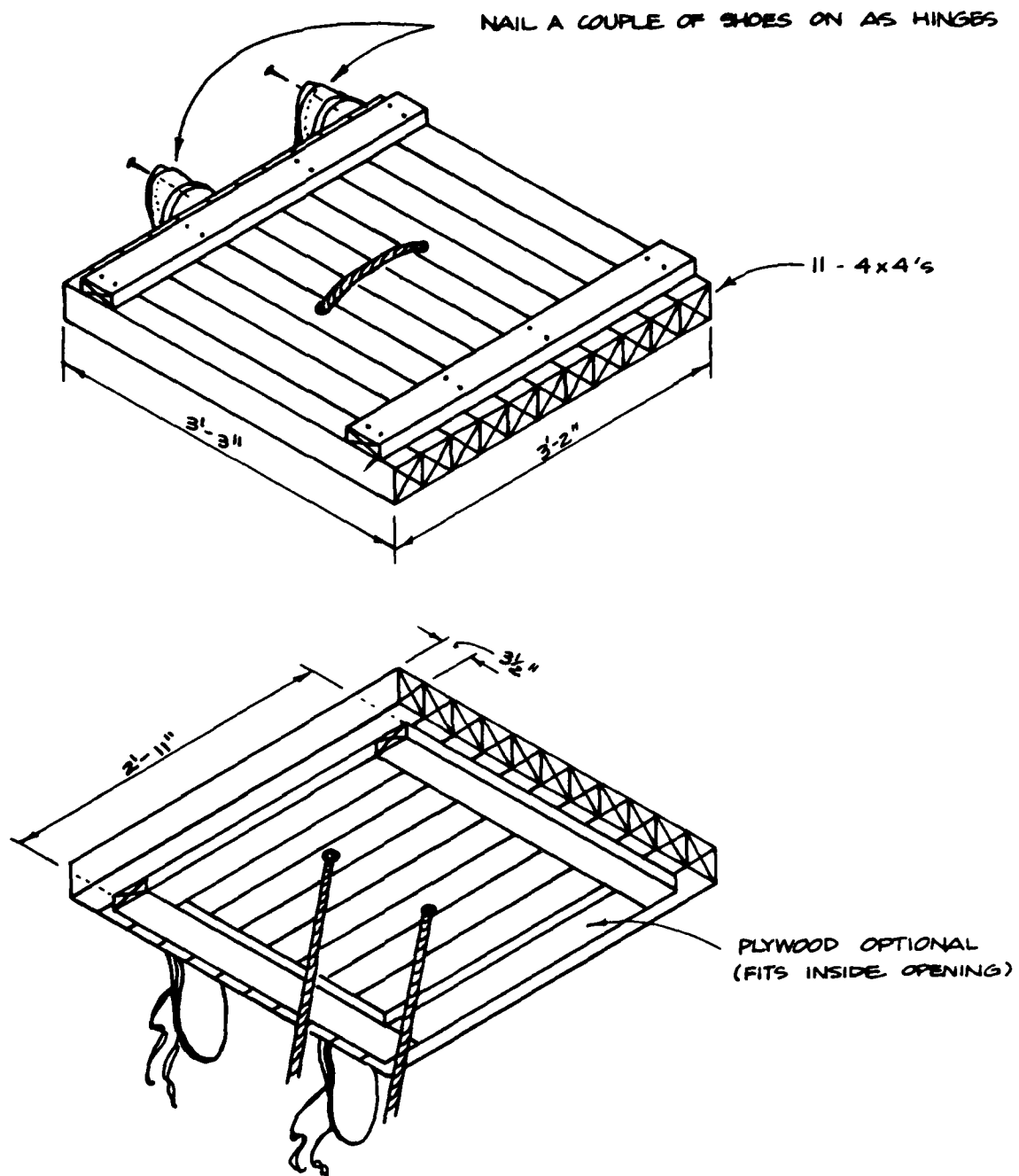

Fig. 6-2. Closure for 40 psi Entrance Structure to Key Worker Shelter (Wood Construction).

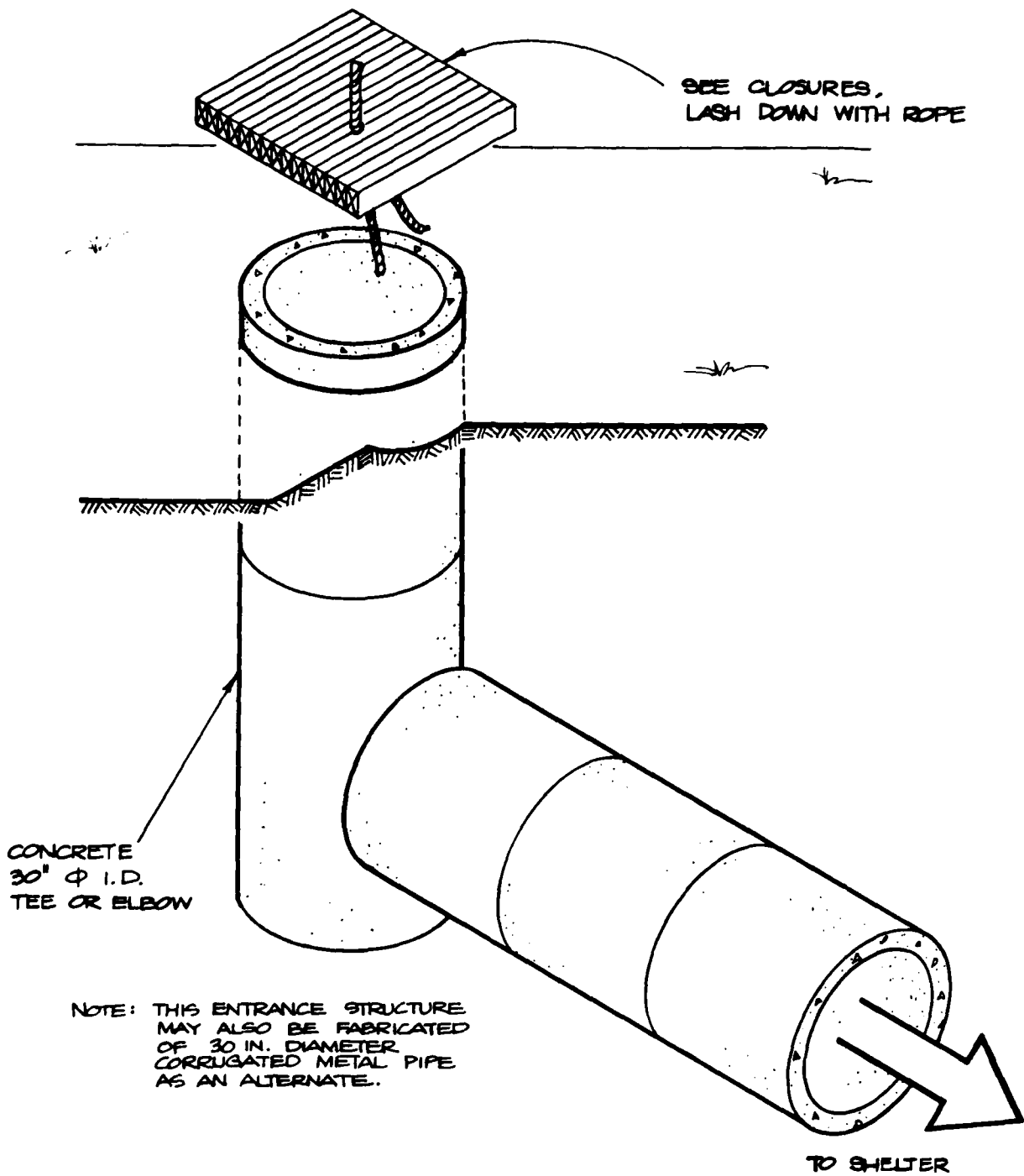

Fig. 6-3. 40 psi Entrance Structure to Key Worker Shelter
(Concrete Pipe Construction)

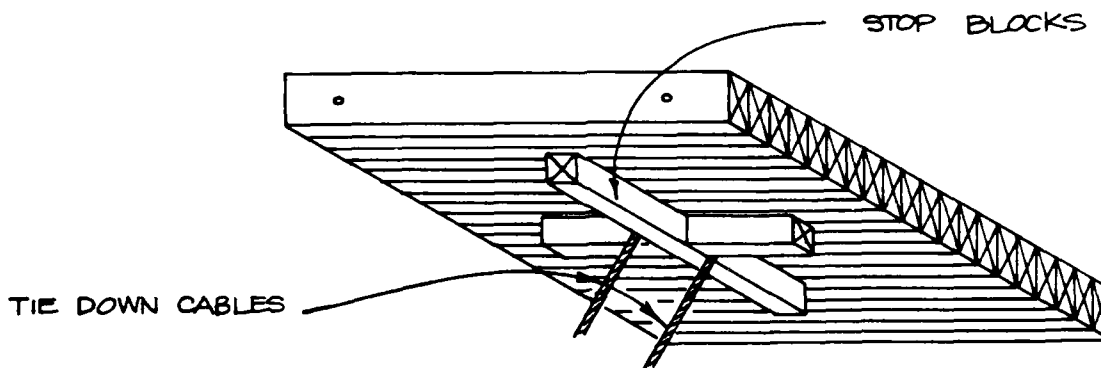
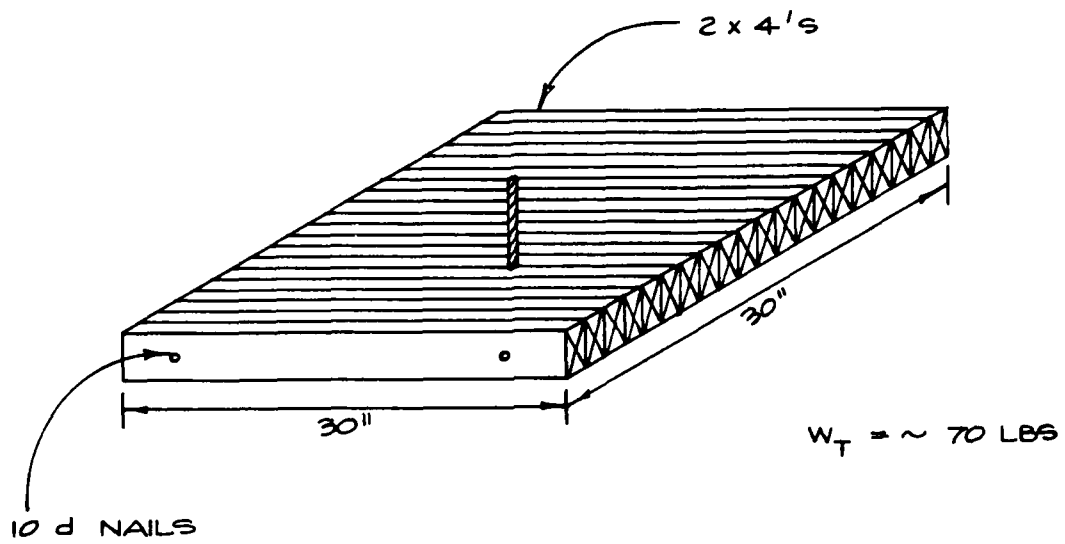

Fig. 6-4. Expedient Manhole Closure, Key Worker Area.

SHELTER CLOSURES

The majority of shelter spaces will require some form of closure in addition to entry closures. Any basement upgraded for a key worker shelter will probably have a stairway, windows, doors, ventilation ducts, or access openings.

These openings can be bridged by using a number of readily available materials, such as wood or steel. Examples of wood that may be used are fence posts, power poles (cut up) railroad ties, solid core doors, and wood beam and plank pieces. Steel plate and rolled beam sections may also be used. Table 6-1 lists alternative materials that may be considered for closures.

The use of wood products for closures requires that material variations affecting wood strength be considered. Wood fence posts, power poles, or railroad ties may be splintered or may exhibit rot or other defects. Generally, poor timber is utility grade when new, and may have loose knots or knotholes. Poor timber may have checks, shakes, or splits. These features are illustrated in Figure 6-5.

TABLE 6-1: CLOSURE MATERIALS

Steel doors	Telephone or power poles
Wood doors (solid)	* Filled sandbags
Toilet doors and partitions	* Filled paper bags
Steel cover plates	* Filled paper boxes
Desk and table tops	* Filled plastic garbage cans
Railroad ties	Brick or concrete block
Plywood	* Filled oil or paper drums
Wood, steel, or concrete fence posts	*filled with sand or earth

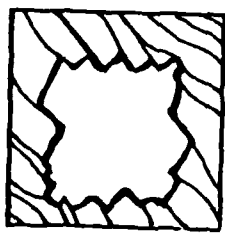
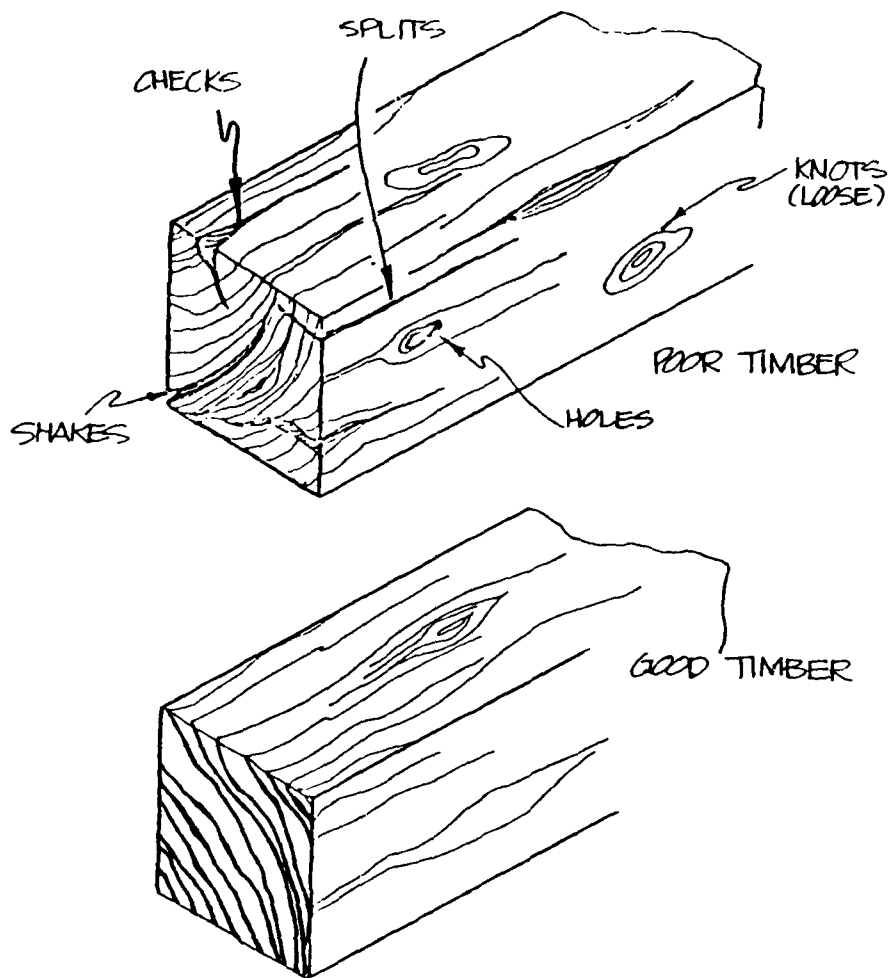

ROTTED TIES OR POSTS

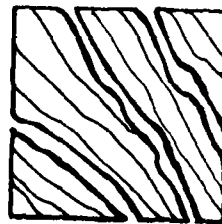

SPLINTERED POSTS / POLES / TIES

Fig. 6-5. Factors Affecting Wood Strength.

Comparison of various materials that may be used to construct closures is shown in Figure 6-6. This figure indicates the maximum opening width that may be spanned without intermediate support for various materials. This chart can be used in two ways:

1. Enter the chart with the minimum opening width, and list the type and thickness of materials that could be used for closures. The list could then be used to determine the most available materials.
2. Enter the chart with a known available resource and determine the width of closure that may be accommodated. This alternative will indicate if a further search for closure resources is required.

As an example, assume a basement shelter has two openings — one that is 18 inches in diameter and the other, 30 inches by 40 inches. The shortest dimensions are 18 inches and 30 inches, respectively. Entering the chart from the left with these dimensions yields the following list of alternative closure materials:

<u>18-inch Diameter</u>	<u>30 inches by 40 inches</u>
6-inch wood post	10-inch wood post
½-inch steel plate	¾-inch steel plate
2-inch timber (good)	3-inch timber (good)
4-inch timber (poor)	6-inch timber (poor)

With these lists, available resources can be compared and determined.

It must be remembered that all shelter closures also require radiation protection. The most straightforward approach is placing earth over the closure if it is horizontal, or piling earth against the closure if it is vertical. The earth placement may require significant personnel time or earth-moving equipment, particularly over basement floors enclosed by

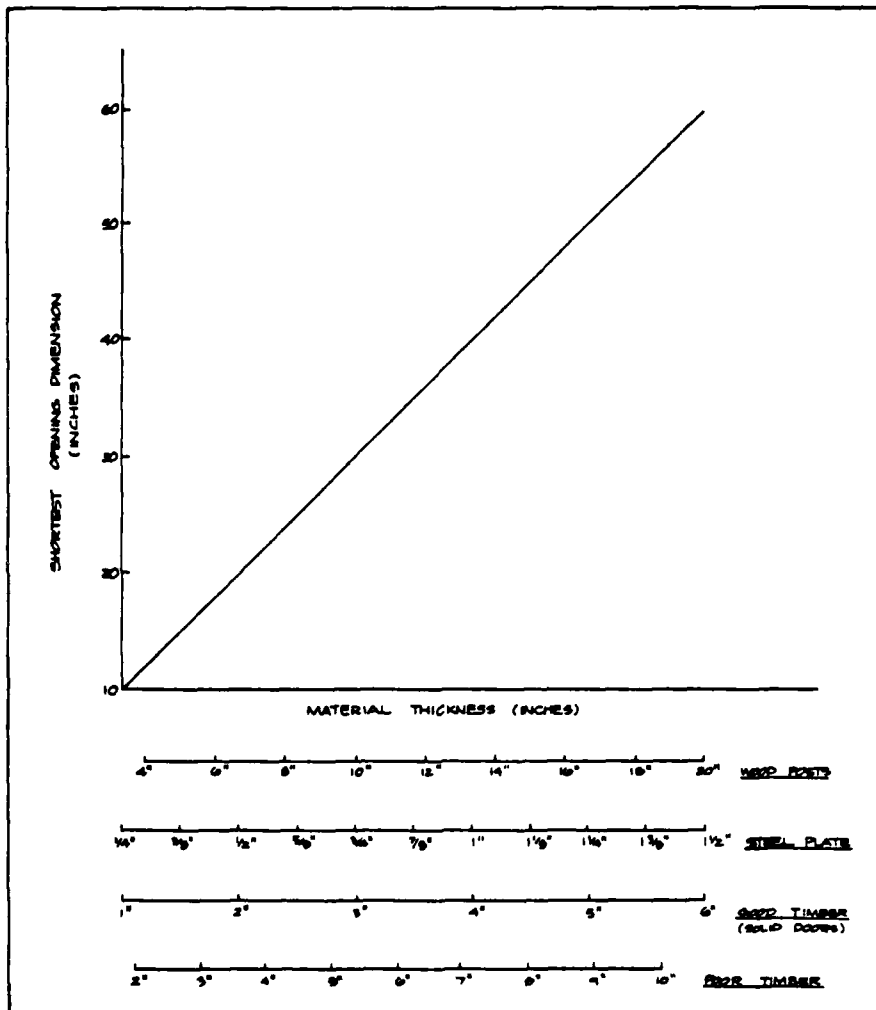

Fig. 6-6. Material Thickness Required to Close Various Openings.

structural improvements. One expedient method is to place the earth (or sand) in containers such as sandbags, paper bags, cardboard boxes, or other containers.

Figures 6-7, 6-8, and 6-9 illustrate different types of basement closures and placement of earth radiation protection.

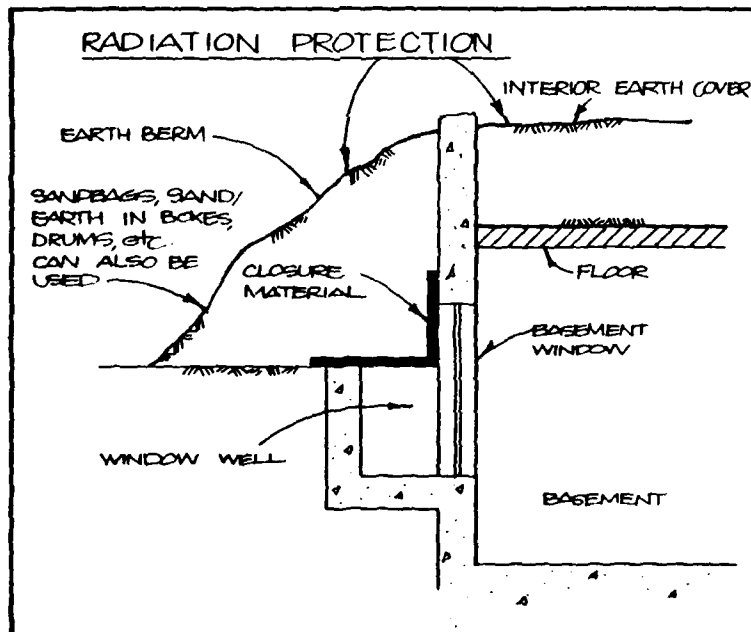
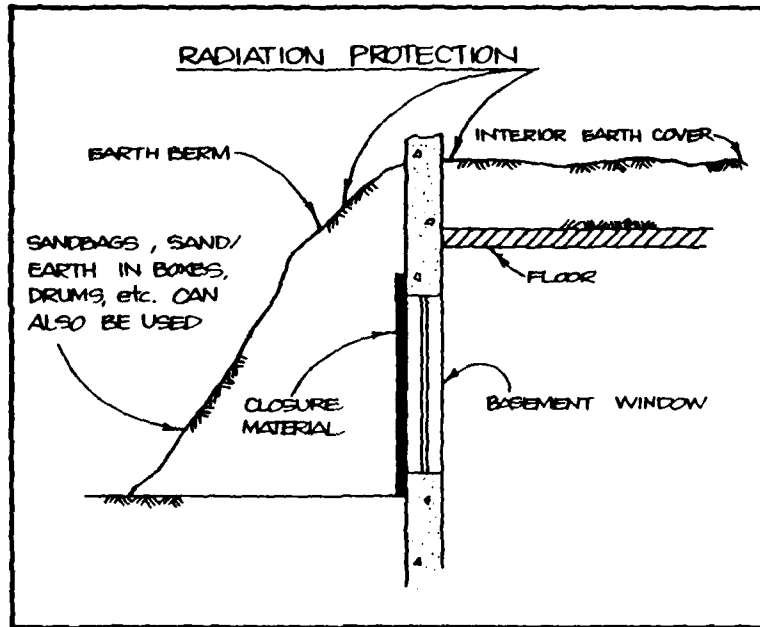

Fig. 6-7. Window Closures.

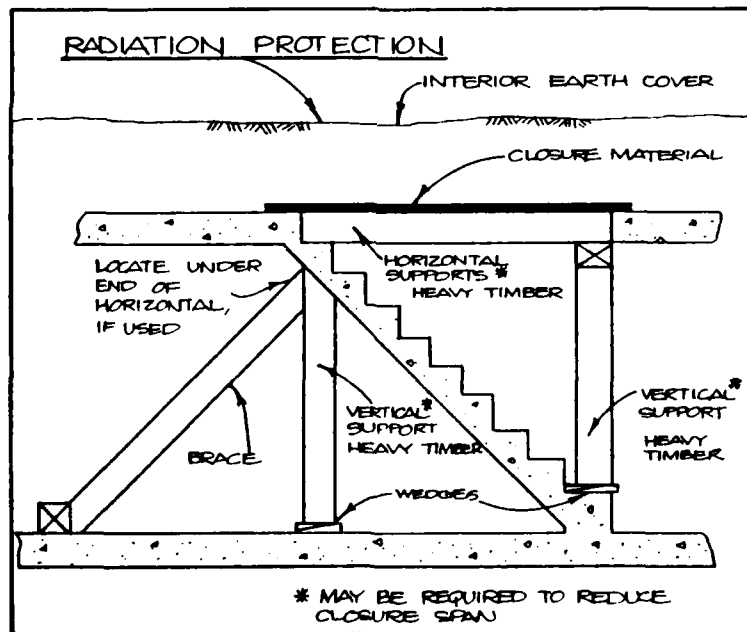
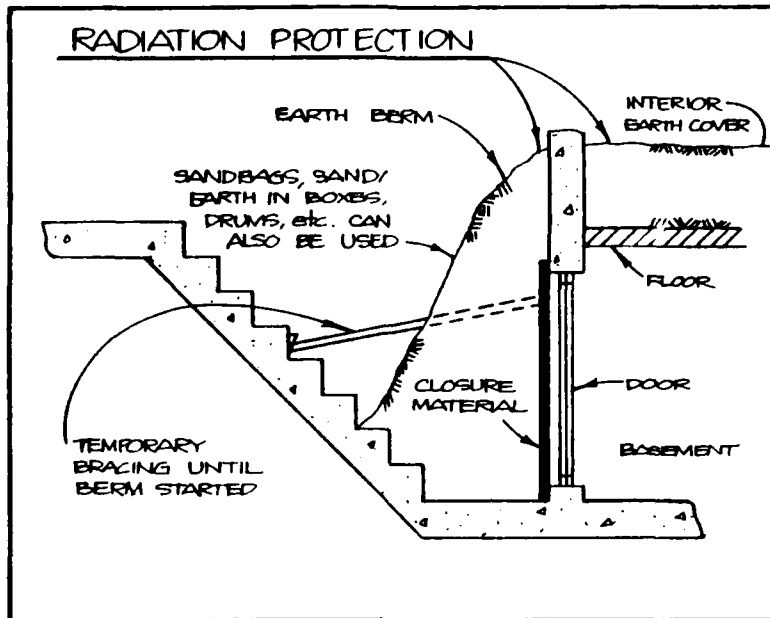

Fig. 6-8. Stair and Door Closures.

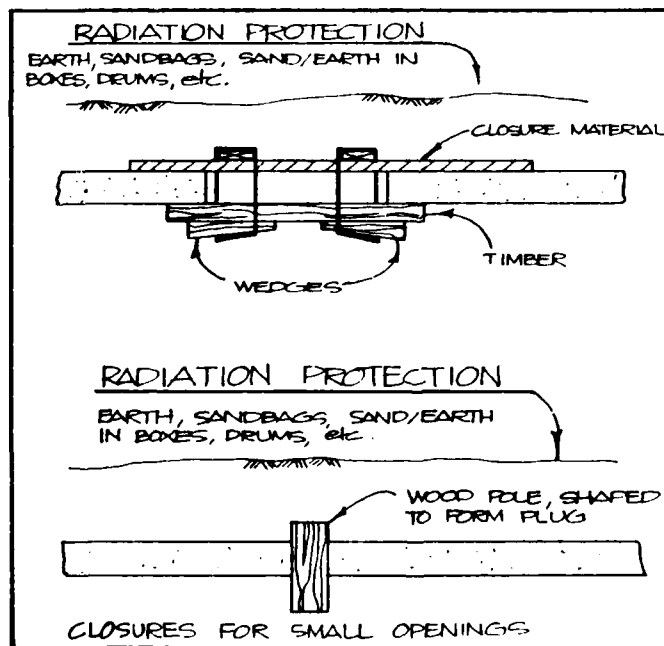
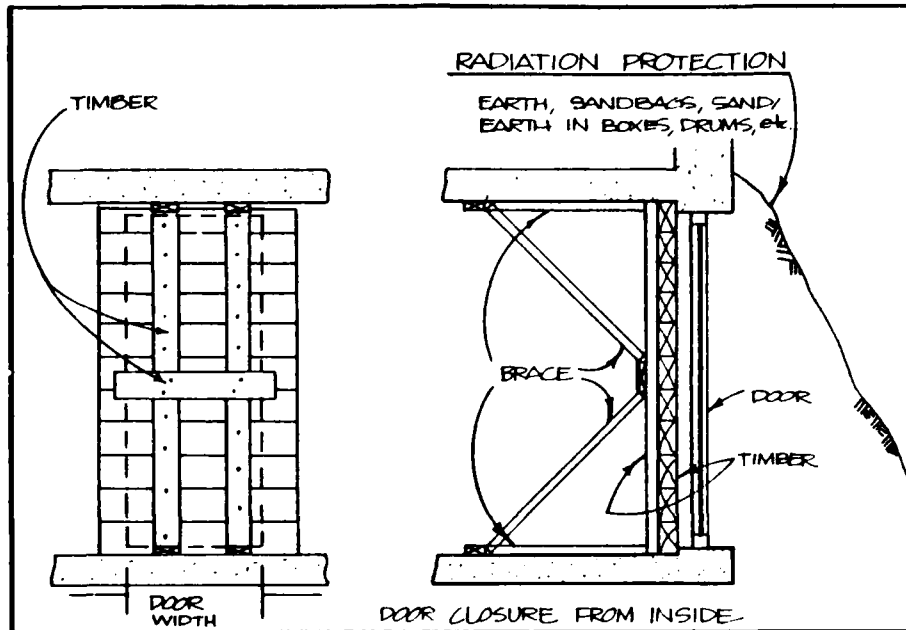

Fig. 6-9. Door and Small Opening Closures.

SECTION 7 - Shelter Stocking

Section 7 SHELTER STOCKING

Provision for emergency food, medical, and other supplies must be made, since warning of an impending nuclear attack may not allow for last-minute purchases. Each key worker shelter established for long stay-time should be provided with a minimum of two weeks food and water for each key worker.

WATER

An adequate water supply is even more important to survival than an adequate food supply. An individual can survive for four weeks without food, but could not survive more than a few days without water or similar fluids. Moreover, tests completed on groups living under shelter conditions have shown that limiting fluids even to the amount necessary for survival can cause considerable discomfort and is more critical than crowding, heat, or boredom.

The minimum water each individual should be provided for survival is one gallon per day — one-half gallon for drinking and one-half gallon for other purposes. The water can be stored in containers in the shelter, or connected to an external storage source independent of municipal supply systems.

FOOD

The most important factors to be considered in providing an adequate food stockpile are nourishment (food value in relation to volume), long shelf life, and ease of preparation. Of less importance are palatability

and cost. A balanced diet is not necessary, since the stockpile is intended to be used for only a limited period of time.

Foods that require little space for storage, that keep for months without refrigeration, and that require little or no cooking are best. Cans and jars sized to meet requirements for single meals are best, as some foods deteriorate rapidly after a container is opened. Foods canned in metal or glass will stay in good condition for six or more months if kept in a dry, cool place (preferably, not above 70°F or below freezing) and protected from sun. Replace canned foods with a fresh supply at least once a year and foods in paper boxes without added protection at least every three months.

Table 7-1 lists foods that are best suited for shelter supplies. The table is designed to specify foods necessary under three different stay-times. The quantities shown in the list are sufficient for one adult and supply 2,000 calories per day.

OTHER SUPPLIES

In addition to food and water, there are a number of other essential supplies that should be stocked in the shelter. The requirements for these items are listed in Table 7-2 for three shelter stay-times.

RADIO

An operating battery-powered radio is an essential part of an effective shelter. Since radio reception is cut down by the shielding necessary to keep out radiation, as soon as the shelter is completed a radio reception check must be made. It will probably be necessary to install an outside antenna to receive CONELRAD broadcasts, which are much weaker than normal broadcasts.

WASTE DISPOSAL

If stay-times in shelters exceed 72 hours, all stored garbage and human wastes should be buried under a minimum of 12 inches of earth to discourage insects and animals from disturbing the wastes. Burial should take place when safe shelter emergence is possible.

FIRE EXTINGUISHERS

Fire extinguishers should be easily accessible and available in the vicinity of the shelters.

TABLE 7-1: REQUIRED WATER AND FOOD SUPPLIES FOR KEY WORKER SHELTERS

Food Item	Long Stay-Time up to 2 weeks		Short Stay-Time 24 to 72 hrs 24 hrs or less	
	Total Weight	Daily Amount	Daily Amount	Daily Amount
<u>Water</u> - Stored in a dark place in clean containers with tightfitting lids. Rinse and refill containers every 3 months	7 gals	2 qts	2 qts	2 qts
<u>Milk</u> - Nonfat, dry	20 oz	1/3 cup	1/3 cup	1/3 cup
Evaporated	14 oz	1 oz	1 oz	
<u>Juices</u> - Tomato, grape, apple. In crown capped bottles only. Store upright	64 oz	1/2 cup	1/2 cup	--
<u>Fruits</u> - Applesauce, pears, peaches. In glass jars, glass lids only. Store upright	112 oz	1 cup	1 cup	--
<u>Vegetables</u> - Corn, peas, beans, spinach	112 oz	1 cup	--	--
<u>Soups</u> - Canned or dehydrated (in can)	112 oz	1 cup	1 cup	1 cup
<u>One-Dish Meals</u> - Canned goods including chicken and rice or noodles, pork and beans, baked kidney beans, chile con carne, and beef stew	208 oz	2 cups	2 cups	2 cups
<u>Spreads</u> - Jam, jelly, marmalade	14 oz	1 tbs	--	--
Peanut butter	14 oz	1 tbs	1 tbs	1 tbs
<u>Crackers</u> - in glass or cans	56 oz	25-30	25-30	25-30
<u>Beverages</u> - Instant coffee or tea, cocoa	4 oz	3 tsp	--	--
<u>Sugar</u>	4 oz	3 tsp	--	--
<u>Hard Candies</u>	16 oz	1 oz	--	--
<u>Salt</u>	4 oz	1/4 oz	1/4 oz	1/4 oz
<u>Sterno</u>	4 cans	1/4 can	1/4 can	1/4 can

TABLE 7-2: KEY WORKER ESSENTIAL SUPPLIES

	Long Stay-Time up to 2 weeks	Short Stay-Times 24 to 72 hrs	Short Stay-Times 24 hrs or less
Cooking & Serving Equipment:			
Frying pan	x	—	—
Cooking unit	x	—	—
Cups	x	x	—
Napkins	x	—	—
Bottle opener	x	—	—
Plates	x	x	—
Matches	x	x	x
Can opener	x	x	x
Double Boiler	x	—	—
Eating utensils	x	x	x
Measuring cup	x	—	—
Pocket knife	x	x	x
Clothing & Bedding:			
Towels	x	x	—
Sleeping bags	x	x	x
Spare clothing	x	—	—
Sanitation Supplies:			
Soap	x	x	—
Toilet tissue	x	x	x
Paper towels	x	x	—
Disinfectant(chlorine, bleach)	x	x	—
Insecticide	x	—	—
Garbage can	x	x	—
Human waste can	x	x	x
Emergency toilet	x	x	—
Plastic bags with ties	x	x	x
First aid kit (large)	x	x	—
Tools & Miscellaneous Items:			
Candles	x	x	—
Hammer	x	x	x
Wrench	x	x	—
Bucket	x	x	x
Shovel	x	x	x
Pliers	x	x	—
Screwdriver	x	x	—
Brooms (small)	x	x	—
Batteries	x	x	x
Flashlight	x	x	x
Calendar	x	x	—
Clock or watch	x	x	x
Axe	x	x	—
Crowbar	x	x	x

TABLE 7-2: KEY WORKER ESSENTIAL SUPPLIES

	Long Stay-Time up to 2 weeks	24 to 72 hrs	Short Stay-Times 24 hrs or less
Emergency Generator, fuel oil, and oil with necessary cords, plugs, lights	x	x	—
Radio	x	x	x
Radiological monitoring equipment	x	x	x
Evacuation Supplies:			
Gasoline	x	x	x
Tent	x	x	—
50-mile map of area	x	x	x
Small motorcycle	x	x	x

Upgrading
APPENDIX A · Tables and
Worksheets

APPENDIX A

Upgrading Tables and Worksheets

UPGRADING TABLES AND WORKSHEETS

This appendix supplements the upgrading techniques described in the manual. The tables, worksheets, and lists are intended to provide additional data and details to facilitate upgrading. The techniques outlined in the manual are straightforward, and are intended to be simple to implement. Below are a number of important facets of the upgrading methods presented.

Shelter Upgrading Details

- o Manual placement of some shoring systems will be difficult because of weight problems.

Wood posts larger than 10 inches by 10 inches and lengths greater than 8 feet will weigh more than 200 lb per post.

Nearly all steel posts 12 feet in length exceed 200 lb per post, with maximum weights to 350 lb.

- o Post lengths are limited to 12 feet, since most basement areas are not expected to exceed this height.
- o When using post and beam upgrading methods, use steel beams only.

Wood beams cannot be used for upgrading, because of crushing of the beam fibers.

Steel beams will require a forklift or other equipment to hoist the beams and hold them in place for placement of the post shores.

Steel bearing plates are required on all steel beams where floor loads are transmitted to the beams by tee-beam or one-way joist types of construction. Bearing plates are not required between the beams and hollow-core slabs.

Steel bearing plates should be tack welded to the steel beams/columns as shown in Figure A-2. Bearing plates should be as wide as the beam flanges, and minimum lengths as specified in Table A-2.

- o Details of post shores and post and beam shores are shown in Figures A-1 and A-2. Additional information is given below.

Steel shores will require bearing plates welded on both ends of the shore.



The length of the steel shore should be carefully measured and cut with bearing plate thickness allowance considered. Total length should allow for placement of wedges to provide a tight fit.

All posts will need to be placed in vertical position, moved laterally into place, and held vertically until wedges are placed.

Steel post shores require steel wedges, and wood post shores require wood wedges. Two wedges are required at each shore in order to provide a tight fit and assure uniform bearing.

- o Worksheets, tables and lists are provided on the following pages, including an example using them.

TABLE A-1: SHORE DESIGNATION

STRUCTURAL TYPE AND DIMENSIONS ↓ SHORE SPACING →	MAXIMUM SHORE LENGTH - FEET				
	TYPE A		TYPE B		TYPE C
	A1	A2	B1	B2	C1
	* to 4' x 4'	4' x 4' + to 5' x 5'	5' x 5' + to 6' x 6'	6' x 6' + to 7' x 7'	7' x 7' + to 8' x 8'
WOOD POST (NOM.)					
6" x 6" 	8'				
6" x 8"	9'	7'			
8" x 8"	14'	11'			
8" x 10"		12'	10'		
10" x 10"				12'	
12" x 12"					12'
STEEL PIPE					
STANDARD STRENGTH 					
4" x 0.237"	8'				
5" x 0.258"	12'				
6" x 0.280"		12'			
8" x 0.322"			12'	8'	
EXTRA STRONG					
3/2" x 0.318"	10'				
4" x 0.337"	12'				
5" x 0.375"		12'			
6" x 0.432"			12'		
DOUBLE EXTRA STRONG					
3" x 0.600"	10'				
4" x 0.674"		12'	10'		
5" x 0.750"				12'	
STRUCTURAL STEEL TUBE					
4" x 4" x 3/16" 	10'				
4" x 4" x 1/4"	12'				
4" x 4" x 5/16"	12'	8'			
4" x 4" x 3/8"	12'	10'			
4" x 4" x 1/2"		12'	8'		
5" x 5" x 3/16"	12'				
5" x 5" x 1/4"		12'			
5" x 5" x 5/16"		12'	8'		
5" x 5" x 3/8"			12'		
5" x 5" x 1/2"			12'	10'	



*minimum shore spacing should not be less than 30" (2.5') on centers under most austere conditions.

TABLE A-1: SHORE DESIGNATION (contd)

STRUCTURAL TYPE AND DIMENSIONS ↓ SHORE SPACING →	MAXIMUM SHORE LENGTH - FEET				
	TYPE A		TYPE B		TYPE C
	A1	A2	B1	B2	C1
	# to 4' x 4'	4' x 4'+ to 5' x 5'	5' x 5'+ to 6' x 6'	6' x 6'+ to 7' x 7'	7' x 7'+ to 8' x 8'
STRUCTURAL STEEL TUBE (cont.)					
6" x 6" x 3/16"		12'			
6" x 6" x 1/4"		12'	10'		
6" x 6" x 5/16"			12'		
6" x 6" x 3/8"				12'	
6" x 6" x 1/2"					10'
7" x 7" x 3/16"		12'	8'		
7" x 7" x 1/4"			12'		
7" x 7" x 5/16"				12'	
8" x 8" x 1/4"				12'	
4" x 3" x 5/16" 	8'				
5" x 3" x 3/16"	8'				
5" x 3" x 1/4"	10'				
5" x 3" x 5/16"	10'				
5" x 3" x 3/8"	10'	8'			
5" x 3" x 1/2"	12'	8'			
6" x 3" x 3/16"	8'				
6" x 3" x 1/4"	10'				
6" x 3" x 5/16"		8'			
6" x 3" x 3/8"	12'	10'			
6" x 4" x 3/16"	12'				
6" x 4" x 1/4"	12'	10'			
6" x 4" x 5/16"		12'	8'		
6" x 4" x 3/8"			10'		
6" x 4" x 1/2"			12'	8'	

* minimum shore spacing should not be less than 30" (2.5') on center under most austere conditions.

TABLE A-1: SHORE DESIGNATION (contd)

STRUCTURAL TYPE AND DIMENSIONS 	MAXIMUM SHORE LENGTH - FEET				
	TYPE A		TYPE B		TYPE C
	A1	A2	B1	B2	C1
	# TO 4' x 4'	4' x 4' to 5' x 5'	5' x 5' to 6' x 6'	6' x 6' to 7' x 7'	7' x 7' to 8' x 8'
STRUCTURAL STEEL TUBE					
(cont.) 7" x 5" x 3/16" 7" x 5" x 1/4" 7" x 5" x 5/16" 7" x 5" x 3/8"		12'			
		12'	10'		
			12'		
			12'	10'	
8" x 4" x 1/4" 8" x 4" x 5/16" 8" x 4" x 3/8"		12'	8'		
			12'		
			12'	8'	
8" x 6" x 1/4" 8" x 6" x 5/16"			12'		
				12'	
STEEL WIDE FLANGE BEAMS					
M5-18.9 5" wide by 5" deep 	12'	8'			
M6-20 6" wide by 6" deep	12'	10'			
W5-16 5" wide by 5" deep	12'				
W5-19 5" wide by 5 1/2" deep	12'	8'			
W6-16 4" wide by 6 1/4" deep	8'				
W6-15 6" wide by 6" deep	12'				
W6-20 6" wide by 6 1/4" deep	12'	10'			
W6-25 6 3/8" wide by 6 3/8" deep		12'	8'		
W8-24 6 1/2" wide by 7 3/8" deep		12'	8'		
W8-20 8 1/2" wide by 8" deep			12'		

* minimum shore spacing should not be less than 30" (2.5') on centers under most austere conditions.

TABLE A-2: BEAM REQUIREMENTS, POST AND BEAM SHORING

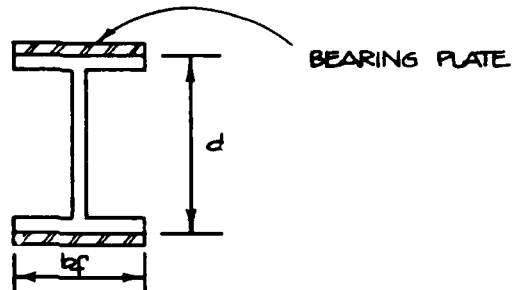

SHORE CLASS	STEEL BEAM DESIGNATION	LIMITING BEAM DIMENSIONS			LENGTH (INCHES) OF BEARING PLATE (MINIMUM)
		BEAM DEPTH - INCHES		MINIMUM BEAM FLANGE WIDTH INCHES bf	
		MINIMUM d	MAXIMUM d		
TYPE A					
A1	W8 x 35	8 1/8	9	8	6 1/2
A1	W10 x 33	9 3/4	11 3/8	8	8 1/2
A1	W12 x 27	12	14 3/8	6 1/2	7
A1	W14 x 20*	13 7/8	14 3/4	5	5 1/2
A1	W16 x 20	15 5/8	16 3/8	5 1/2	5 3/4
A2	W10 x 60	10 1/4	11 3/8	10 1/8	7 3/4
A2	W12 x 50	12 1/4	13 3/8	8 1/8	8 3/4
A2	W14 x 43	13 3/8	14 3/4	8	11 1/2
A2	W16 x 40*	16	16 3/8	7	11 1/2
A2	W18 x 40	17 7/8	18 1/2	6	11 1/4
TYPE B					
B1	W12 x 84	12 1/2	14 3/8	12 1/8	9 1/4
B1	W14 x 74	14 1/4	14 3/4	10 1/8	10 1/2
B1	W16 x 71	16 1/8	16 3/8	8 1/2	9 1/2
B1	W18 x 60	18 1/4	18 1/2	7 1/2	12
B1	W21 x 55*	20 3/4	21 1/2	8 1/4	13 3/4
B1	W24 x 55	23 1/2	24 3/4	7	12 3/4
B2	W18 x 90	18 1/8	10 1/2	11 3/4	13 1/4
B2	W21 x 90	21 1/8	21 1/2	9	11
B2	W24 x 70*	23 3/8	24 3/4	9	16
B2	W27 x 84	26 3/4	27 1/4	10	15
TYPE C					
C1	W21 x 127	21 1/4	21 1/2	13	14 3/4
C1	W24 x 110	24 1/8	24 3/4	12	17 3/4
C1	W27 x 102	27 1/8	27 1/4	10	17 1/2
C1	W30 x 99*	29 3/8	30 3/8	10 1/2	17 3/4

* optimum section based on weight per foot.

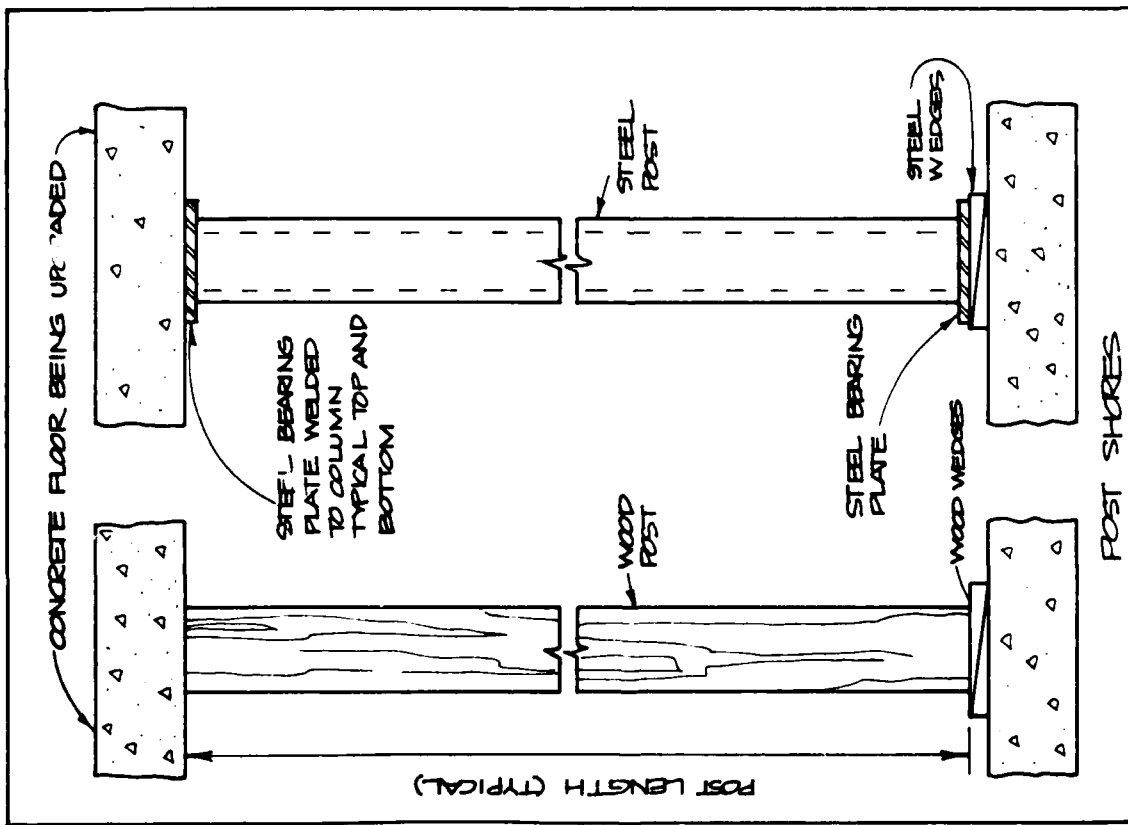
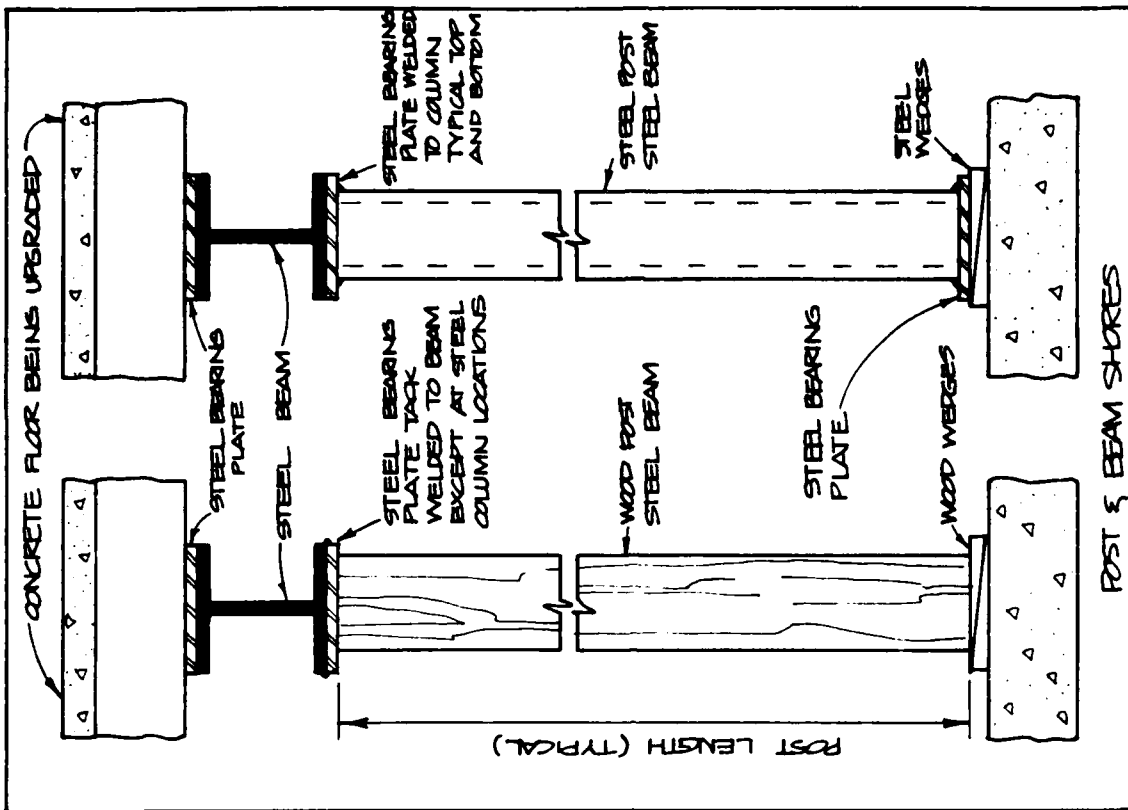
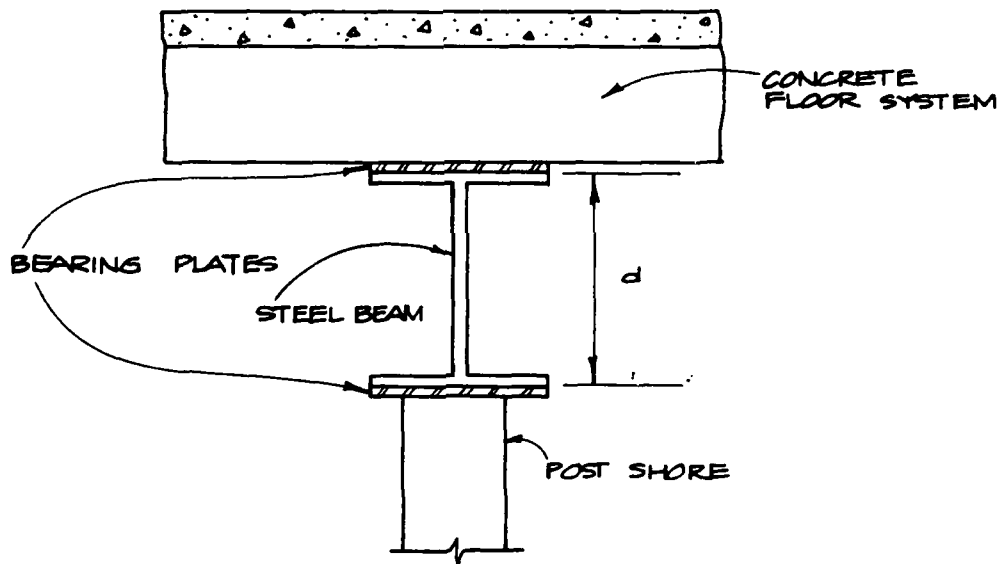
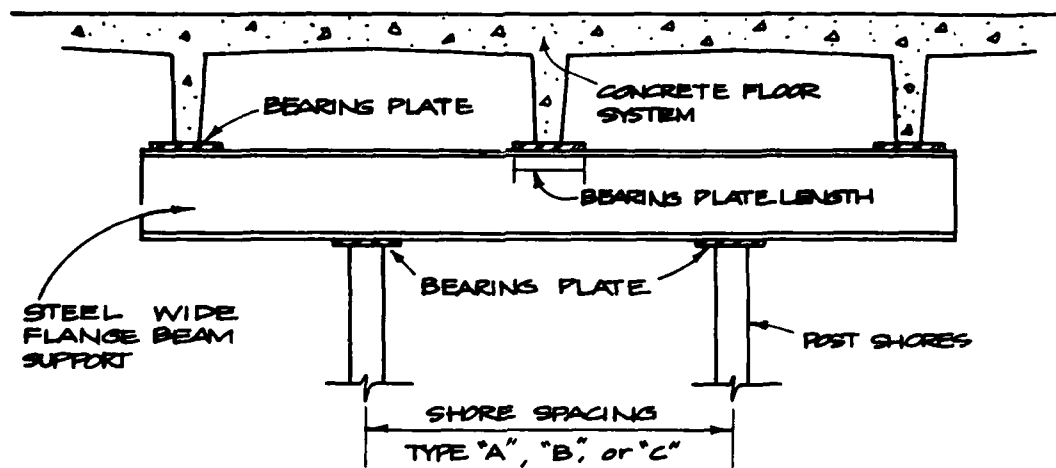

Fig. A-1. Post Shore Details.



NOTE: BEARING PLATES MUST BE USED BETWEEN BEAM AND SUPPORTED FLOOR MEMBERS ABOVE, AND AT BOTH ENDS OF POST SHORES.

Fig. A-2. Post and Beam Shoring System Details.

Radiation Protection

The most readily available resource to protect a sheltered population against the long-term effects of radiation is a mass of earth. Two feet of earth in conjunction with an 8-inch thick concrete slab will provide a protection factor of 1000.

Movement and placement of earth around the perimeter of a building area selected as a Key Worker shelter may be a significant task. In order to provide an adequate estimate of time for earth radiation protection, Figures A-3 and A-4 are provided.

Earth quantities for the 5-man basement shelter shown in the Example (see pages A-24 to A-33) may be analyzed as follows:

For the ceiling area, the earth radiation protection should extend beyond the shelter area a minimum of one-half the shelter dimension on the building interior, and should be bermed around the exterior perimeter area.

Floor Area

$(16 \text{ ft} + 8 \text{ ft})^2 \times 2 \text{ ft} \div 27 = 43$ cubic yards of earth on the concrete slab.

Perimeter Berm (2 sides)

$(3 \text{ ft high} \times 1\frac{1}{2} \text{ ft wide}) + (3 \text{ ft} \times 4.5 \text{ ft} \div 2) = 11.25 \text{ ft}^2$ of berm area.

$11.25 \times 24 \times 2 \div 27 = 20$ cubic yards

Total: $43 + 20 = 63$ cubic yards

Placement of the material using hand labor would take 20 man-hours (Figure A-3) or three men nearly 8 hours (Line 5, Worksheet 6). For shelters where earthmoving equipment may be used, use Figure A-4 to calculate the time requirements.

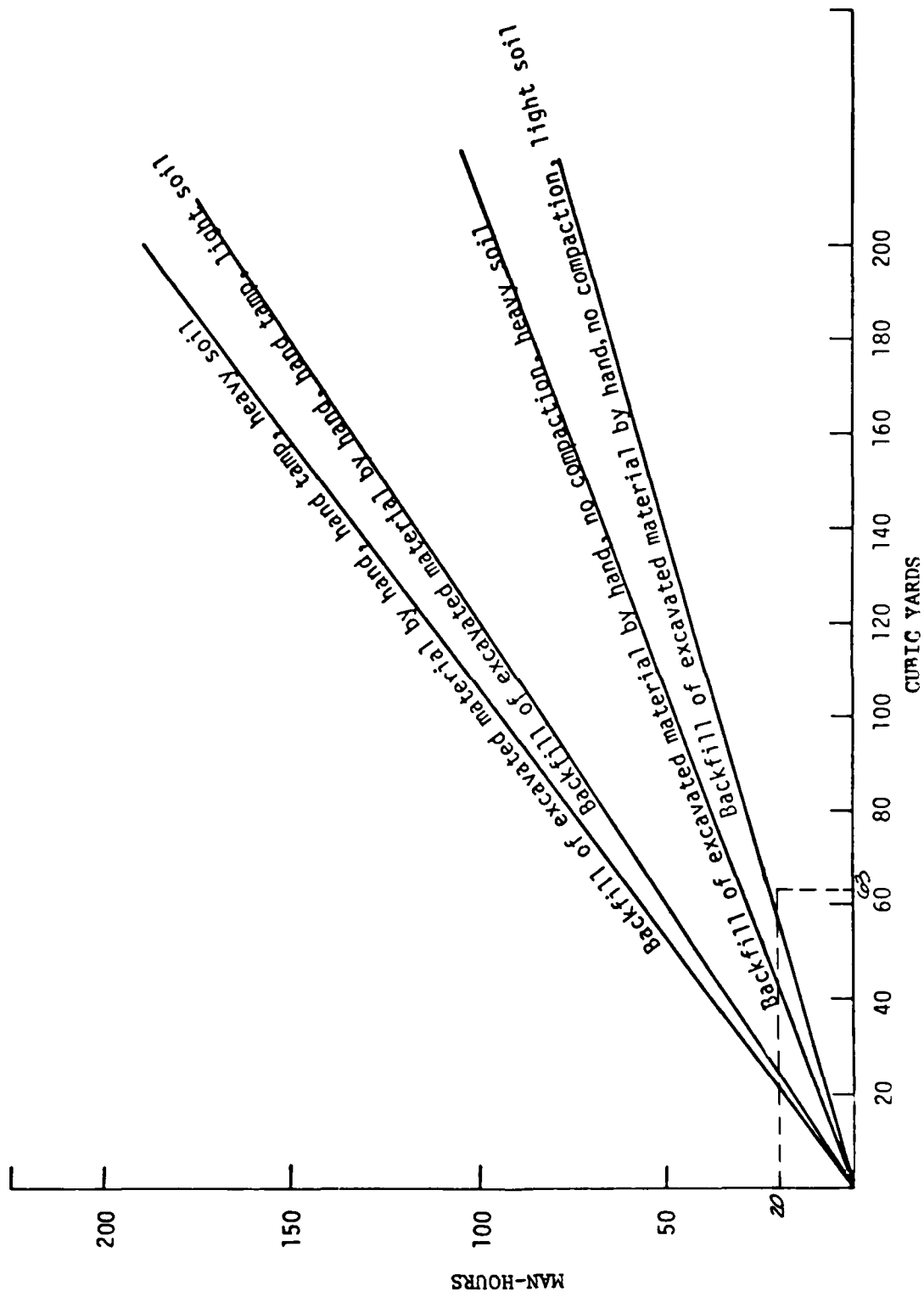

Fig. A-3. Time Requirements for Hand Earthmoving Processes.

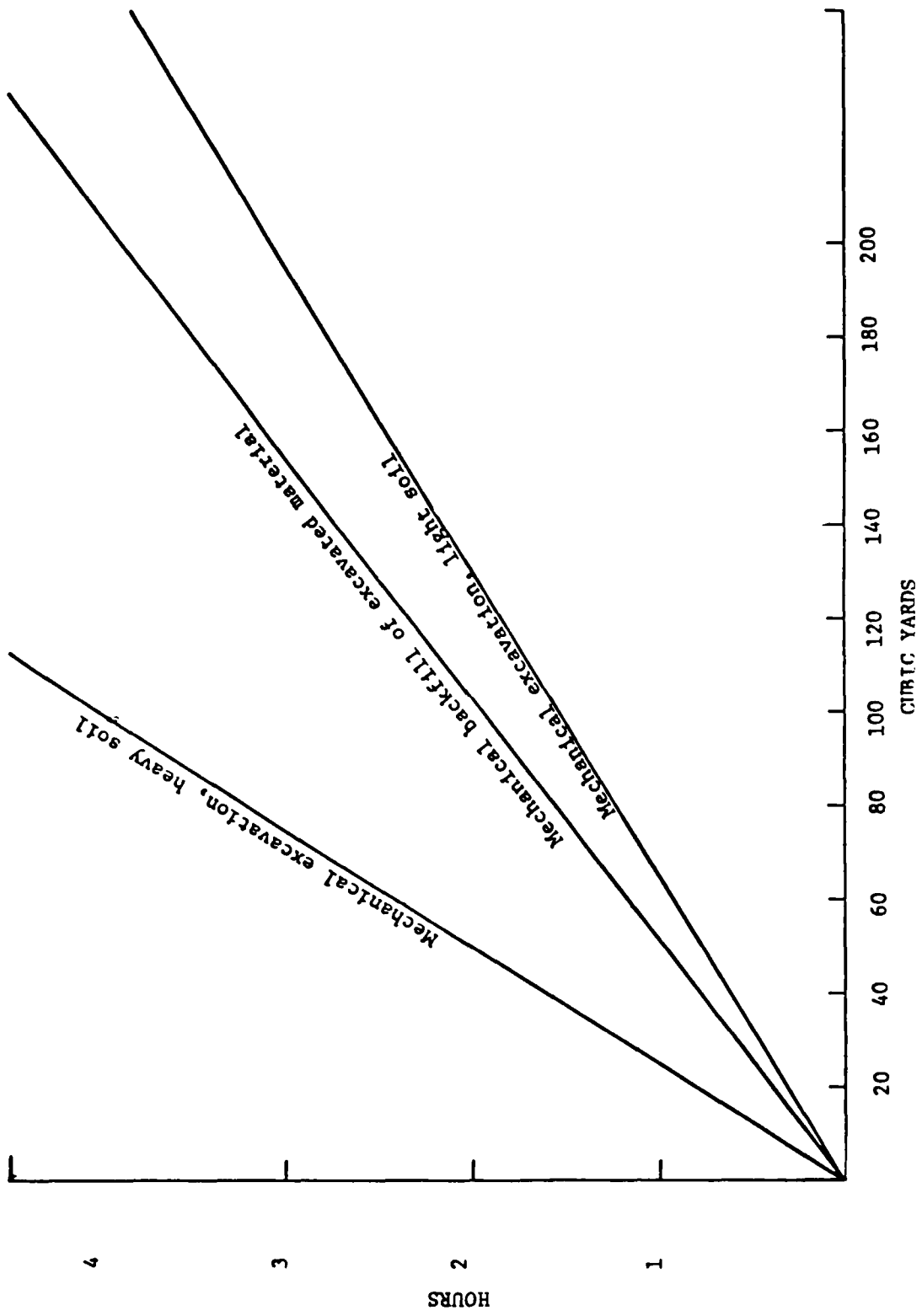

Fig. A-4. Time Requirements for Mechanical Earthmoving Processes.

WORKSHEET LEGEND

The worksheets supplied in this appendix are designed for multiple use; i.e., basement and expedient shelters.

<u>Worksheet Number</u>	<u>Description</u>	<u>Basement Shelter</u>	<u>Expedient Shelter</u>
1	Shelter space requirements	✓	✓
2	Shelter stocking space allocation	✓	✓
3	Upgrading basement structures	✓	
4	Building sketch	✓	✓
5	Upgrading analysis	✓	✓
6	Upgrading sequence priority	✓	✓
7	Expedient shelter checklist		✓
8	Expedient shelter burial priority		✓
9	Resource list - Post and Beam	✓	✓
10	Resource list - Posts	✓	✓

KEY WORKER SHELTER — SPACE REQUIREMENTS

Company Name: _____

Address: _____

Total Key Workers to be sheltered: _____

Shelter Space Needs:

1) Floor Space: $10 \times \text{Total Key Workers} =$ _____ square feet

2) Allowance for Shelter Stocking and
Equipment Storage (from Worksheet 2) = _____ square feet

Total floor space _____ square feet

3) Air volume: $65 \times \text{Total Key Workers} =$ _____ cubic feet

4) Ventilation: 3 cubic feet per minute
per person:

$3 \times \text{Total Key Workers} =$ _____ CFM*

* Provide for additional capacity in
humid areas, up to 40 CFM per person

Minimum Shelter Size must be: _____ by _____ = _____ square feet

KEY WORKER SHELTER STOCKING SPACE ALLOCATION

Shelter stocking requirements for two week stay time:

Equivalent Floor Space
(square feet)

- 1) Total the space required in the shelter(s) for water, food and supplies, including additional space for personal items brought by workers. These supplies should be accessible without leaving the shelter. _____
- 2) Identify special foods, supplies, or special dietary needs for any of the key workers. Provide a 3-week supply for such persons and make necessary designations on supplies to indicate their shelter destination and proposed use. _____
- 3) Provide a radio for each shelter, and test it inside the shelter for performance under shelter conditions. Provide extra batteries. _____
- 4) Provide sealed cans for food and human waste _____
- 5) Provide radiation detector in each shelter _____
- 6) Provide ventilation equipment _____
- 7) Provide fire extinguishers _____
- 8) Provide emergency power equipment _____

Total Floor Space Allowance: _____ *

* Total to be entered on Line 2, Worksheet 1.

UPGRADING BASEMENT STRUCTURES

1) Available basement area? _____ Is it upgradable? _____

Use of space _____

2) Space Upgrading: Length _____ Width _____ Height _____

Area = _____ square feet Volume = _____ cubic feet

3) Type of Construction

Two-Way Slabs

One-Way Slabs

Flat plate and flat slabs _____

One-way joist and one-way slab, beam and girder _____

Waffle slabs _____

Double tee _____

Slab and girder _____

Hollow-core _____

One-way slab and girder _____

4) Type of Upgrading

Two-Way Slabs

One-Way Slabs

Post shores _____

Post and beam shores _____

Fig. ___ page ___

Fig. ___ Page ___

5) Determine Shore Spacing

One quarter span (length) = _____

One quarter span (width) = _____

Shore spacing grid = _____ by _____ *

Use Type ___ Post Shores (Table A-1) _____ by _____

Use Type ___ Beam Shores (Table A-2) _____

* For waffle slab, post must be placed at grid intersections.

BUILDING SKETCH

Building Name _____

Scale _____

Facility No. or Address _____

Building Sketch Checklist

External dimensions _____ Aperture locations _____
Wall height (to roof or 2nd story) _____ Aperture dimensions sill/ht/width _____
Construction materials _____ Nearest distance to soil _____
Floor to grade _____ Slope of grade _____
Interior dimensions _____ Placement of nonbearing partitions _____
Location & dimension columns _____ Bearing walls _____ Beams _____
Indicate joist direction _____ Joist spans _____ Joist centers _____
Indicate joist type & dimensions _____

UPGRADING ANALYSIS

1) Determine shore size and availability (Tables A-1 and A-2)

Availability		Structural Type & Size	How Many?	Shore Type	Length	Remarks
Our Plant	Local Supplier					
POSTS	(Table A-1)					
BEAMS	(Table A-2)					

2) Number of exits, windows, and other passages for closures required?

Dimensions: _____ x _____
 _____ x _____
 _____ x _____
 _____ x _____

3) Ventilation equipment

Is shelter adequately ventilated? _____

Can shelter space be adequately ventilated? _____

Are ventilation resources available? _____

WORKSHEET 6

KEY WORKER SHELTERS UPGRADING SEQUENCE PRIORITY

UPGRADING SEQUENCE PRIORITY CHECKLIST	ESTIMATED TIME FRAME				
	EQUIPMENT NEEDED	EQUIPMENT TIME	NO. OF PERSONNEL	MAN-HOURS REQUIRED	TIME USED HOURS
1) Obtain resource list, re-sources - move to shelter for upgrading.	Trucks				
2) Remove debris, clean shelter & surrounding area.	Trucks & Tools				
3) Lay out upgrading (shoring, closures, radiation protection), make initial checks of materials, cut materials and check fit.	Power tools Hand tools & Supplies				
4) Complete upgrading including entry structures.	"				
5) Complete movement of earth for radiation protection.	Dozers, Loaders Wheelbarrows Buckets, Shovels etc.				
6) Install ventilation equipment.	Power tools Hand tools & Supplies				
7) Install interior shelter features - toilets, shelves	Power and Hand Tools				
8) Clean up & stock shelter with all food and supplies	Misc. Hand Tools				
9) Provide for waste disposal area.	Misc. Excava- tion Tools				

KEY WORKER SHELTERS UPGRADING SEQUENCE PRIORITY (contd)

UPGRADING SEQUENCE PRIORITY CHECKLIST	ESTIMATED TIME FRAME				TIME USED HOURS
	EQUIPMENT NEEDED	EQUIPMENT TIME	NO. OF PERSONNEL	MAN-HOURS REQUIRED	
10) Implement Shelter management program.					
11) Expedient shelter burial if not completed previous- ly (from Worksheet 8). Eliminate Item 5 above.					
TOTAL ELAPSED TIME ≤					72.0 hrs.

AD-A100 511

SCIENTIFIC SERVICE INC REDWOOD CITY CA
SHELTER UPGRADING MANUAL: KEY WORKER SHELTERS. (U)
MAY 81 R S TANSLEY, R D BERNARD
SSI-8012-7

F/6 15/3

UNCLASSIFIED

ENW-C-0153

NL

2 of 2
AD-A100 511



END
DATE
FILMED
7-81
DTIC

EXPEDIENT SHELTER BURIAL PRIORITY

EXPEDIENT SHELTER ESTIMATED TIME FRAME					
EXPEDIENT SHELTER BURIAL PRIORITY	EQUIPMENT NEEDED	EQUIPMENT TIME	NO. OF PERSONNEL	MAN-HOURS REQUIRED	TIME USED HOURS
1) Provide transportation and personnel to move expedient shelter to site location	Trucks, Cranes, Forklifts				
2) Obtain equipment and excavate for burial, partial burial or berms, including entries.	Backhoes, Bulldozers, Front Loader				
3) Provide modification to structure for entry holes for ventilation and access of shelterees.	Special tools and equipment				
4) Place shelter in excavation, install entry, ventilation and appurtenant items such as floors.	Cranes or other lifting equipment				
5) Install large shelter stock items and backfill and berm structure.					
TOTAL ELAPSED TIME					*

* Transfer to item 11), Worksheet 6.

RESOURCE LIST

Required

1. Posts, steel or wood
2. Beams, steel
3. Nails
4. Hammer
5. Saw
6. Wedges
7. Tape measure/yardstick, etc.
8. _____
9. _____
10. _____

Quantity

Available

RESOURCE LIST

Required

Quantity

Available

- 1. Posts, steel or wood _____
- 2. Nails _____
- 3. Hammer _____
- 4. Saw _____
- 5. Wedges _____
- 6. Tape measure/yardstick, etc. _____
- 7. _____
- 8. _____
- 9. _____
- 10. _____

_____	_____
_____	_____
_____	_____
_____	_____
_____	_____
_____	_____
_____	_____
_____	_____
_____	_____
_____	_____

EXAMPLE OF USE OF
UPGRADING WORKSHEETS,
LISTS, AND TABLES

WORKSHEET 1

KEY WORKER SHELTER — SPACE REQUIREMENTS

Company Name: WIDGET WORKS, INC.

Address: 321 THING-A-MABOB RD.

Total Key Workers to be sheltered: 5

Shelter Space Needs:

1) Floor Space: $10 \times \text{Total Key Workers} =$ 50 square feet

2) Allowance for Shelter Stocking and
Equipment Storage (from Worksheet 2) = 23 square feet

Total floor space 73 square feet

3) Air volume: $65 \times \text{Total Key Workers} =$ 325 cubic feet

4) Ventilation: 3 cubic feet per minute
per person:

$\text{Total Key Workers} =$ 15 CFM*

* additional capacity in
areas, up to 40 CFM per person

Minimum Shelter Size must be: 8 by 10 = 80 square feet

KEY WORKER SHELTER STOCKING SPACE ALLOCATION

Shelter stocking requirements for two week period

Equivalent Floor Space
(square feet)

- | | |
|---|-----------|
| 1) Total the space required in the shelter(s) for water, food and supplies, including additional space for personal items brought by workers. These supplies should be accessible without leaving the shelter. | <u>10</u> |
| 2) Identify <u>special</u> foods, supplies, or special dietary needs for any of the key workers. Provide a 3-week supply for such persons and make necessary designations on supplies to indicate their shelter destination and proposed use. | <u>2</u> |
| 3) Provide a radio for each shelter, and test it inside the shelter for performance under shelter conditions. Provide extra batteries. | <u>1</u> |
| 4) Provide sealed cans for food and human waste | <u>4</u> |
| 5) Provide radiation detector in each shelter | <u>1</u> |
| 6) Provide ventilation equipment | <u>2</u> |
| 7) Provide fire extinguishers | <u>1</u> |
| 8) Provide emergency power equipment | <u>2</u> |

Total Floor Space Allowance: 23 *

* Total to be entered on Line 2, Worksheet 1.

UPGRADING BASEMENT STRUCTURES

1) Available basement area? YES Is it upgradable? YES

Use of space STORAGE

2) Space Upgrading: Length 10' Width 10' Height 0' (SEE WORKSHEET 4)

Area = 250 square feet Volume = 2040 cubic feet

3) Type of Construction

Two-Way Slabs

One-Way Slabs

Flat plate and flat slabs _____

One-way joist and one-way slab, beam and girder _____

Waffle slabs _____

Double tee _____

Slab and girder _____

Hollow-core _____

One-way slab and girder ✓ PAGE 4-15

4) Type of Upgrading

Two-Way Slabs

One-Way Slabs

Post shores _____

Post and beam shores PAGE 4-16

Fig. ___ page ___

FIG. A-1, PAGE A-7

FIG. A-2, PAGE A-8

5) Determine Shore Spacing

One quarter span (length) = 4.0'

One quarter span (width) = 4.0'

Shore spacing grid = 4' by 4' *

Use Type A1 Post Shores (Table A-1) 4'-0" by 4'-0"

Use Type A1 Beam Shores (Table A-2) 4'-0"

* For waffle slab, post must be placed at grid intersections.

BUILDING SKETCH

Building Name WIDGET WORKS, INC.

Scale 1" = 10'

Facility No. or Address BASEMENT AREA (PORTION)

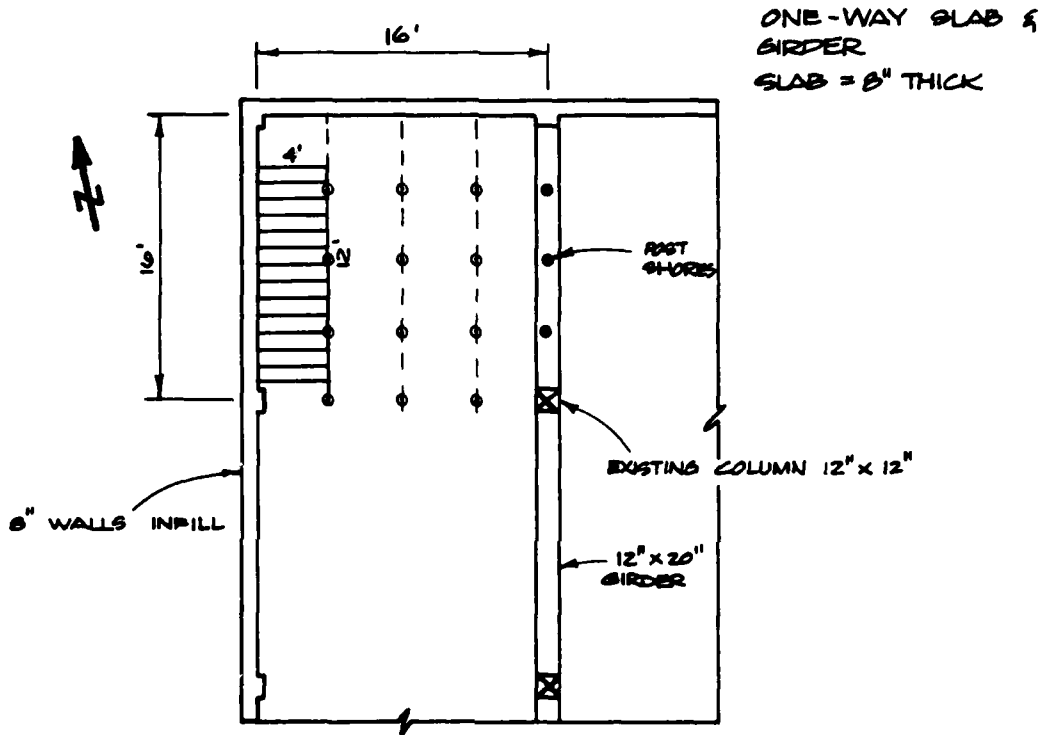

Building Sketch Checklist

External dimensions 17' x 17' Aperture locations STAIRWAY ONLY
 Wall height (to roof or 2nd story) 8' Aperture dimensions sill/ht/width
 Construction materials CONCRETE Nearest distance to soil 250'
 Floor to grade 7' Slope of grade FLAT
 Interior dimensions 16' x 16' Placement of nonbearing partitions NONE
 Location & dimension columns ✓ Bearing walls EXT. Beams 12" x 20"
 Indicate joist direction NONE Joist spans NA Joist centers NA
 Indicate joist type & dimensions NA

UPGRADING ANALYSIS

1) Determine shore size and availability (Tables A-1 and A-2)

Availability		Structural Type & Size	How Many?	Shore Type	Length	Remarks
Our Plant	Local Supplier					
POSTS (Table A-1)						
✓		WOOD 6" x 8"	12 EACH	FIR POSTS	10'	NEED 15 TOTAL
	✓	STANDARD 5" x 0.250"	10 EACH	STEEL PIPE	8'	NEED 3 TOTAL
BEAMS (Table A-2)						
	✓	W10 x 33	100 L.F.	STEEL BEAM		NEED 3 BEAMS 16' LONG

2) Number of exits, windows, and other passages for closures required?

1 STAIR WELL

Dimensions: 4' x 12' USE 1/4" STEEL PLATE
 OR 5" THICK TIMBER (GOOD)

_____ x _____

_____ x _____

_____ x _____

3) Ventilation equipment

Is shelter adequately ventilated? NO

Can shelter space be adequately ventilated? YES THROUGH STAIR WELL CLOSURE

Are ventilation resources available? NO - MUST FABRICATE OR PURCHASE

KEY WORKER SHELTERS UPGRADING SEQUENCE PRIORITY

UPGRADING SEQUENCE PRIORITY CHECKLIST	ESTIMATED TIME FRAME				
	EQUIPMENT NEEDED	EQUIPMENT TIME	NO. OF PERSONNEL	MAN-HOURS REQUIRED	TIME USED HOURS
1) Obtain resource list, re-sources - move to shelter for upgrading.	Trucks	4	2	8	4
2) Remove debris, clean shelter & surrounding area.	Trucks & Tools	2	2	4	2
3) Lay out upgrading (shoring, closures, radiation protection), make initial checks of materials, cut materials and check fit.	Power tools Hand tools & Supplies	-	3	6	2
4) Complete upgrading including entry structures.	"	-	3	24	8
5) Complete movement of earth for radiation protection.	Dozers, Loaders Wheelbarrows Buckets, Shovels etc.	-	3	24	8 *
6) Install ventilation equipment.	Power tools Hand tools & Supplies	-	3	12	4
7) Install interior shelter features - toilets, shelves	Power and Hand Tools	-	2	8	4
8) Clean up & stock shelter with all food and supplies	Misc. Hand Tools	-	2	10	8
9) Provide for waste disposal area.	Misc. Excava- tion Tools	1	1	4	4
SUBTOTALS					44

NOT APPLICABLE TO EXPEDIENT SHELTERS.

KEY WORKER SHELTERS UPGRADING SEQUENCE PRIORITY (contd)

UPGRADING SEQUENCE PRIORITY CHECKLIST	ESTIMATED TIME FRAME					TIME USED HOURS
	EQUIPMENT NEEDED	EQUIPMENT TIME	NO. OF PERSONNEL	MAN-HOURS REQUIRED		
10) Implement Shelter management program.	—	—	VARIES	—		3
11) Expedient shelter burial if not completed previous- ly (from Worksheet 8). Eliminate Item 5 above.	—	—	—	—		**
TOTAL ELAPSED TIME						47 ≤ 72.0 hrs.

** IF EXPEDIENT SHELTER IS SELECTED, 47 HOURS PLUS 33 HOURS
(WORKSHEET 8) LESS (ITEM 5) @ HRS = 72 HOURS, MAXIMUM
ALLOWABLE UPGRADING TIME.

EXPEDIENT SHELTER BURIAL PRIORITY

EXPEDIENT SHELTER ESTIMATED TIME FRAME						
EXPEDIENT SHELTER BURIAL PRIORITY	EQUIPMENT NEEDED	EQUIPMENT TIME	NO. OF PERSONNEL	MAN-HOURS REQUIRED	TIME USED HOURS	
1) Provide transportation and personnel to move expedient shelter to site location	Trucks, Cranes, Forklifts	7	2	14	7	
2) Obtain equipment and excavate for burial, partial burial or berms, including entries.	Backhoes, Bulldozers, Front Loader	8	3	24	8	
3) Provide modification to structure for entry holes for ventilation and access of shelterees.	Special tools and equipment	—	4	32	8	
4) Place shelter in excavation, install entry, ventilation and appurtenant items such as floors.	Cranes or other lifting equipment	4	3	12	4	
5) Install large shelter stock items and backfill and berm structure.		6	4	24	6	
TOTAL ELAPSED TIME					33	*

* Transfer to item 11), Worksheet 6.

RESOURCE LIST

<u>Required</u>	<u>Quantity</u>	<u>Available</u>
1. Posts, steel or wood	12 WOOD 6" by 6" 3 STEEL PIPE 5" by 0.250	AT PLANT PURCHASE
2. Beams, steel	3 EACH 16' LONG	PURCHASE
3. Nails	NONE NEEDED	
4. Hammer	2 EACH	✓
5. Saw	1 EACH	✓
6. Wedges STEEL AND WOOD	STEEL 6 EACH WOOD 24 EACH	PURCHASE FABRICATE AT PLANT
7. Tape measure/yardstick, etc.	2 MINIMUM	✓
8. <u>STEEL BEARING PLATES</u>	6 EACH 6" SQUARE * 12 EACH 6 1/2" by 6" **	PURCHASE
9. <u>STAIR WELL CLOSURE</u>	1 EACH WITH ACCESS AND VENTILATION HOLES	FABRICATE
10. <u>VENTILATION EQUIPMENT</u>	1 EACH	PURCHASE AND/OR FABRICATE

* WELD TO 5" STEEL PIPE AT ENDS

** TACK WELD TO BOTTOM SIDE OF BEAM

DISTRIBUTION LIST

(one copy each unless otherwise specified)

Federal Emergency Management Agency
Mitigation and Research
Attn: Administrative Officer
Washington, D.C. 20472 (60)

Assistant Secretary of the Army (R&D)
Attn: Assistant for Research
Washington, D.C. 20301

Chief of Naval Research
Washington, D.C. 20360

Mr. Phillip M. Smith
Associate Director,
Natural Resources and Commercial
Services
Office of Science and Technology
Policy
Executive Office Bldg
Washington, D.C. 20500

Defense Technical Information
Center
Cameron Station
Alexandria, VA 22314 (12)

Civil Defense Research Project
Oak Ridge National Laboratory
Attn: Librarian
P.O. Box X
Oak Ridge, TN 37830

Mr. Edward L. Hill
Research Triangle Institute
Post Office Box 12194
Research Triangle Park
North Carolina 27709

Commanding Officer
U.S. Naval Civil Engineering
Laboratory
Attn: Document Library
Port Hueneme, CA 93041

AFWL/Civil Engineering Division
Attn: Technical Library
Kirtland Air Force Base
Albuquerque, NM 87117

Director, U.S. Army Engineer
Waterways Experiment Station
Post Office Box 631
Vicksburg, MS 39180

Dikewood Corporation
1613 University Blvd, N.E.
Albuquerque, NM 39180

Department of Energy
Office of Environment
Operational and Environmental
Safety Division (EV131)
Environmental Protection and
Public Safety Branch
Attn: L.J. Deal
Dr. Rodolf J. Englemann
Washington, D.C. 20545

GARD, Inc.
7449 North Natchez Ave
Niles, IL 60640

Director
Ballistics Research Laboratory
Attn: Document Library
Aberdeen Proving Ground, MD 21005

Civil Engineering Center/AF/PRECET
Attn: Technical Library
Wright-Patterson Air Force Base
Dayton, OH 45433

Director, Army Materials and
Mechanics Research Center
Attn: Technical Library
Watertown, MA 02170

The Rand Corporation
Attn: Document Library
1700 Main Street
Santa Monica, CA 90401

Director, U.S. Army Engineer
Waterways Experiment Station
Attn: Document Library
Post Office Box 631
Vicksburg, MS 39180

Mr. Donald A. Bettge
Mitigation and Research
Federal Emergency Management Agency
1725 I Street, N.W.
Washington, D.C. 20472

Dr. Lewis V. Spencer
Radiation Theory Section
National Bureau of Standards
Washington, D.C.

Mr. Arnold
Institute
35th Street
Chicago, IL 60616

Mr. Chuck Wilton
Scientific Service, Inc.
517 East Bayshore
Redwood City, CA 94063

Mr. Samuel Kramer, Chief
Office of Federal Building Technology
Center for Building Technology
National Bureau of Standards
Washington, D.C. 20234

Dr. Clarence R. Mehl
Department 5230
Sandia Corporation
Box 5800, Sandia Base
Albuquerque, NM 87115

Director, Defense Nuclear Agency
Attn: Mr. Tom Kennedy
Washington, D.C. 20305

Director, Defense Nuclear Agency
Attn: Technical Library
Washington, D.C. 20305

Emergency Technology Division
Oak Ridge National Laboratory
Post Office Box X
Oak Ridge, TN 37830
Attn: Librarian

Technology & Management
1850 N. Whittier
Suite 910
Hollywood, CA 90028

Logistics Agency
Preparedness Office
Richmond, VA 23297

H.L. Murphy Associates
Box 1727
San Mateo, CA 94401

Department of Energy
Headquarters Library, G-49
Washington, D.C. 20545

Disaster Research Center
Ohio State University
404B West 17th Avenue
Columbus, OH 43210

Dr. Charles Fritz
National Academy of Sciences
2101 Constitution Avenue
Washington, D.C. 20418

Dr. Leon Goure
Science Applications, Inc.
1710 Goodridge Dr.
P.O. Box 1303
McLean, VA 22102

Agbabian Associates
250 North Main Street
21 Sequoyia Dr. #41

Telephone Laboratories
41 Main Road
Whippany, NJ 07981
Attn: Mr. E. Witt
Mr. R. May
Mr. J. Foss

Ballistic Research Library
Attn: Librarian
Aberdeen Proving Ground, MD 21005

Mr. Jack C. Greene
Greenwood
Route 4 - Box 85A
Bakerville, NC 28705

Dr. William Chenault
Human Science Research
Westgate Industrial Park
P.O. Box 370
McLean, VA 22010

University of Florida
Civil Defense Technical Services
Center
College of Engineering
Department of Engineering
Gainesville, FL 32601

Dr. Leo Schmidt
Institute for Defense Analysis
400 Army-Navy Drive
Arlington, VA 22202

Mr. James Beck and Associates
1000 Palos Avenue
Palo Alto, CA 94306

Science Applications, Inc.
1710 Goodridge Drive
P.O. Box 1303
McLean, VA 22102

Mr. Kenneth Kaplan
Management Science Associates
P.O. Box 239
Los Altos, CA 94022

Research Institute of Protective
Construction
Attn: Mr. J. Gut
2 AUF DER NAUER
CH — 8001 Zurich
SWITZERLAND

Sandia National Laboratory
Box 5800
Albuquerque, NM 87185

Los Alamos Scientific Laboratory
Attn: Document Library
Los Alamos, NM 87544

Mr. Richard K. Laurino
Center for Planning and Research, Inc.
2483 E. Bayshore Road
Palo Alto, CA 94303

Nuclear Engineering Department
Duncan Annex
Purdue University
Lafayette, IN 47907

SHELTER UPGRADING MANUAL: KEY WORKER SHELTERS
Scientific Service, Inc., Redwood City, CA May 1981
Contract No. EMM-C-0153, Work Unit 1128A

SHELTER UPGRADING MANUAL: KEY WORKER SHELTERS
Scientific Service, Inc., Redwood City, CA May 1981
Contract No. EMM-C-0153, Work Unit 1128A

This manual is one of a series being developed in support of the civil defense concept of crisis relocation planning. One basic element of crisis relocation is plant site protection of key workers who operate essential facilities through a crisis period.

This manual is one of a series being developed in support of the civil defense concept of crisis relocation planning. One basic element of crisis relocation is plant site protection of key workers who operate essential facilities through a crisis period.

The manual is designed to be used by planners and plant personnel in risk areas. It presents a methodology for evaluating basement areas and expedient shelters (for industries without available basements); provides alternative methods to develop the necessary structural upgrading for blast and fallout protection; and contains charts, pictorial representations, and worksheets that complement and simplify the utility of the manual. The information contained in the manual is based on previously developed structural information, but has yet to be tested in the field.

The manual is designed to be used by planners and plant personnel in risk areas. It presents a methodology for evaluating basement areas and expedient shelters (for industries without available basements); provides alternative methods to develop the necessary structural upgrading for blast and fallout protection; and contains charts, pictorial representations, and worksheets that complement and simplify the utility of the manual. The information contained in the manual is based on previously developed structural information, but has yet to be tested in the field.

The manual is in looseleaf format to permit removal of pertinent worksheets for developing upgrading plans for a specific structure and to allow for the insertion of new data and techniques as they become available.

The manual is in looseleaf format to permit removal of pertinent worksheets for developing upgrading plans for a specific structure and to allow for the insertion of new data and techniques as they become available.

SHELTER UPGRADING MANUAL: KEY WORKER SHELTERS
Scientific Service, Inc., Redwood City, CA May 1981
Contract No. EMM-C-0153, Work Unit 1128A

SHELTER UPGRADING MANUAL: KEY WORKER SHELTERS
Scientific Service, Inc., Redwood City, CA May 1981
Contract No. EMM-C-0153, Work Unit 1128A

This manual is one of a series being developed in support of the civil defense concept of crisis relocation planning. One basic element of crisis relocation is plant site protection of key workers who operate essential facilities through a crisis period.

This manual is one of a series being developed in support of the civil defense concept of crisis relocation planning. One basic element of crisis relocation is plant site protection of key workers who operate essential facilities through a crisis period.

The manual is designed to be used by planners and plant personnel in risk areas. It presents a methodology for evaluating basement areas and expedient shelters (for industries without available basements); provides alternative methods to develop the necessary structural upgrading for blast and fallout protection; and contains charts, pictorial representations, and worksheets that complement and simplify the utility of the manual. The information contained in the manual is based on previously developed structural information, but has yet to be tested in the field.

The manual is designed to be used by planners and plant personnel in risk areas. It presents a methodology for evaluating basement areas and expedient shelters (for industries without available basements); provides alternative methods to develop the necessary structural upgrading for blast and fallout protection; and contains charts, pictorial representations, and worksheets that complement and simplify the utility of the manual. The information contained in the manual is based on previously developed structural information, but has yet to be tested in the field.

The manual is in looseleaf format to permit removal of pertinent worksheets for developing upgrading plans for a specific structure and to allow for the insertion of new data and techniques as they become available.

The manual is in looseleaf format to permit removal of pertinent worksheets for developing upgrading plans for a specific structure and to allow for the insertion of new data and techniques as they become available.

