

MEMORANDUM REPORT ARBRL-MR-03100

RADIO FREQUENCY OSCILLATOR TECHNIQUE
FOR MONITORING VELOCITY AND STRUCTURAL
INTEGRITY OF PROJECTILES DURING
THEIR EXIT FROM THE MUZZLE

Rurik K. Loder
Jimmy Q. Schmidt

April 1981



US ARMY ARMAMENT RESEARCH AND DEVELOPMENT COMMAND
BALLISTIC RESEARCH LABORATORY
ABERDEEN PROVING GROUND, MARYLAND

Approved for public release; distribution unlimited.

DTIC QUALITY INSPECTED 3

Destroy this report when it is no longer needed.
Do not return it to the originator.

Secondary distribution of this report by originating
or sponsoring activity is prohibited.

Additional copies of this report may be obtained
from the National Technical Information Service,
U.S. Department of Commerce, Springfield, Virginia
22161.

The findings in this report are not to be construed as
an official Department of the Army position, unless
so designated by other authorized documents.

*The use of trade names or manufacturers' names in this report
does not constitute indorsement of any commercial product.*

UNCLASSIFIED

SECURITY CLASSIFICATION OF THIS PAGE (When Data Entered)

REPORT DOCUMENTATION PAGE		READ INSTRUCTIONS BEFORE COMPLETING FORM
1. REPORT NUMBER MEMORANDUM REPORT ARBRL-MR-03100	2. GOVT ACCESSION NO.	3. RECIPIENT'S CATALOG NUMBER
4. TITLE (and Subtitle) RADIO FREQUENCY OSCILLATOR TECHNIQUE FOR MONITORING VELOCITY AND STRUCTURAL INTEGRITY OF PROJECTILES DURING THEIR EXIT FROM THE MUZZLE		5. TYPE OF REPORT & PERIOD COVERED Memorandum Report
		6. PERFORMING ORG. REPORT NUMBER
7. AUTHOR(s) Rurik K. Loder Jimmy Q. Schmidt		8. CONTRACT OR GRANT NUMBER(s)
9. PERFORMING ORGANIZATION NAME AND ADDRESS U.S. Army Ballistic Research Laboratory ATTN: DRDAR-BLI Aberdeen Proving Ground, MD 21005		10. PROGRAM ELEMENT, PROJECT, TASK AREA & WORK UNIT NUMBERS 1L162618AH80
11. CONTROLLING OFFICE NAME AND ADDRESS U.S. Army Armament Research & Development Command U.S. Army Ballistic Research Laboratory ATTN: DRDAR-BL Aberdeen Proving Ground, MD 21005		12. REPORT DATE APRIL 1981
		13. NUMBER OF PAGES 35
14. MONITORING AGENCY NAME & ADDRESS (if different from Controlling Office)		15. SECURITY CLASS. (of this report) UNCLASSIFIED
		15a. DECLASSIFICATION/DOWNGRADING SCHEDULE
16. DISTRIBUTION STATEMENT (of this Report) Approved for public release; distribution unlimited		
17. DISTRIBUTION STATEMENT (of the abstract entered in Block 20, if different from Report)		
18. SUPPLEMENTARY NOTES This report contains a written summary of the technical presentation "Radio Frequency Oscillator Technique for Monitoring Velocity and Structural Integrity of Projectiles During Their Exit From the Muzzle" given at the 30th Aeroballistic Range Association Meeting, Burlington, Vt.		
19. KEY WORDS (Continue on reverse side if necessary and identify by block number) Ballistic Range Instrumentation Launch Dynamics Muzzle Velocity Radio Frequency Oscillator		
20. ABSTRACT (Continue on reverse side if necessary and identify by block number) jmk Accurate knowledge of projectile velocity and integrity at muzzle exit is requisite to many aspects of research, development, product assurance, quality control, and field employment of projectile-gun systems. Standard methods for obtaining such information have severe limitations of applicability. As a result of a recent thrust program in the technology area of projectile-gun dynamics, a radio frequency oscillator technique has been developed and successfully tested for the 105mm M68 tank gun system. It provides real time (continued)		

UNCLASSIFIED

SECURITY CLASSIFICATION OF THIS PAGE(When Data Entered)

measurement of projectile exit from the muzzle and, hence, projectile muzzle velocity. The electronic pulse associated with the measurement can also be used to trigger auxiliary instrumentation such as x-ray pulses and photographic cameras and to automatically adjust the corresponding delay times to the correct projectile muzzle velocity.

UNCLASSIFIED

SECURITY CLASSIFICATION OF THIS PAGE(When Data Entered)

TABLE OF CONTENTS

	Page
LIST OF ILLUSTRATIONS.	5
I. INTRODUCTION	7
II. MUZZLE VELOCITY MEASUREMENT TECHNIQUES	7
III. RADIO FREQUENCY OSCILLATOR INSTRUMENTATION TO MEASURE PROJECTILE MUZZLE VELOCITY	8
IV. APPLICATION OF THE RADIO FREQUENCY OSCILLATOR VELOCIMETER. .	12
V. RADIO FREQUENCY OSCILLATOR VELOCIMETER, DOUBLE INDUCTANCE COIL DESIGN.	24
VI. SUMMARY.	28
REFERENCES	29
DISTRIBUTION LIST.	31

LIST OF ILLUSTRATIONS

Figure	Page
1. Basic Block Diagram of the Muzzle Velocity Measurement System.	9
2. Cross-Sectional View of Sensor Coil Assembly Rigidly Attached to the Muzzle.	9
3. Sensor Coil Arrangement	10
4. Output Waveforms of a 105mm Proof Slug and an M392 Projectile.	12
5. Example of the Signature of the Gas Flow and Projectile Motion Through the Inductance Coil.	13
6. Comparison of 105mm Proof Slugs Exiting a Gun Tube Aligned and Misaligned.	14
7a. Example of a Signature for the M392 Projectile.	15
7b. Example of a Signature for the M392 Projectile.	16
8. Time Series for the 75mm HE(TP) Projectile, Rd. No. 4 . . .	17
9. Recorded Profile for the 75mm HE(TP) Projectile, Rd. No. 4	18
10. Time Series for the 75mm HE Projectile, Rd. No. 13.	19
11. Time Interval Pulse (Square Wave) for the 75mm HE Projectile, Rd. No. 13.	19
12. Recorded Profile for the 75mm HE Projectile, Rd. No. 13 . . .	20
13. Velocity Pulse and Muzzle Pressure for 40mm Test Slug, Rd. No. 61.	21
14. Recorded Profile for the 40mm Test Slug, Rd. No. 61	22
15. Time Series for the 40mm Test Slug, Rd. No. 163	23
16. Recorded Profile for the 40mm Test Slug, Rd. No. 163.	24
17. Double Inductance Coil Design	25
18. Schematic Diagram of the Differential Sensor Circuitry.	25
19. Block Diagram of the Logic Circuit for the Signal Processor	26

I. INTRODUCTION

In the ballistics of projectile-gun systems we encounter parameters which are common to both exterior and interior ballistics. They are associated with the launch of the projectile and define the final projectile motion at release from the muzzle. Among these parameters, projectile muzzle velocity is the most important and the easiest to obtain experimentally. Its absolute value directly relates to propellant performance, gun tube wear, and projectile range.

In this report we will briefly outline the experimental techniques which are available for determining projectile muzzle velocity, describe the radio frequency oscillator velocimeters which we have developed and tested, show some representative examples of data sets which we have obtained for the 40mm, 75mm and 105mm gun systems, concurrently discuss the information reducible from the recorded data, and discuss the advantages of the radio frequency oscillator technique over conventional methods.

II. MUZZLE VELOCITY MEASUREMENT TECHNIQUES

Various measurement techniques have been developed over the years to determine the muzzle velocity of projectiles either directly or indirectly. The most commonly used methods utilize

- velocity coils
- light screens
- break wires
- photographic recordings
- strain gauges
- pressure gauges
- microwave interferometer/Doppler radar

Most of these methods are based on recording the time required for the projectile to pass through two or more points of known distance. The velocity is then computed as the quotient of distance divided by time. The velocity, however, is really an averaged velocity between the two points of reference. To obtain the true muzzle velocity, an extrapolation from the location of measurement to the muzzle position is usually necessary. Each of the aforementioned measurement techniques has its advantages and disadvantages which are well known to this community.

In the first four methods, the transducing elements are arranged downrange from the gun. They require accurate alignment with the firing line as well as accurate distance measurements between the individual transducers. Of these methods, the photographic techniques are the most accurate ones; however, they are usually cumbersome and expensive.

In contrast to the first four methods, where the muzzle velocity of the projectile relative to the ground is computed from the collected data retroceding the projectile trajectory in time, the next two measurement techniques - the strain and pressure gauge methods - approximate the relative velocity between the projectile and the recoiling gun at muzzle exit preceding the projectile trajectory in time. These two techniques employ transducers which are mounted on/in the gun tube wall near the muzzle. Again, accurate distance measurement between the transducing elements is necessary. To obtain reasonably good estimates for the muzzle velocity, one has to employ a complex data analysis program which at the moment is not available for real time measurements. Both measurement techniques can be used to trigger auxiliary instrumentation such as x-ray pulses and photographic equipment. Compared to the first four methods, the strain and the pressure methods have the advantage that they permit firings at all azimuth and elevation angles; however, their accuracy is inadequate.

Microwave interferometry can be employed with the microwave probe either outside the gun or inserted into the muzzle end of the tube. The first procedure is standard. Depending on the experimental arrangement, we can monitor the motion of the projectile while traveling in-bore, immediately after launch and downrange. The second procedure was pioneered by the Epsilon Lambda Electronics Corp. at Batavia, Illinois, for a 35mm air defense gun system. We intend to procure such a cannon mounted system in the future, check it out in detail and compare it with other velocity measuring methods. Currently, microwave radar mounted on the gun is the most suitable field setup. However, this arrangement permits us only to follow the free flight trajectory of projectiles. In addition, the high cost of the radar equipment prohibits its use on every gun.

During the last decade a muzzle velocity measurement system utilizing radio frequency oscillator techniques has been developed successfully. We will now discuss this new measurement technique in more detail.

III. RADIO FREQUENCY OSCILLATOR INSTRUMENTATION TO MEASURE PROJECTILE MUZZLE VELOCITY

The muzzle velocity measurement system consists of three basic units: the sensor, the signal processor and the data processor (Figure 1). The sensor, mounted on the muzzle of the gun, provides a pulse with amplitude proportional to the geometric shape of the projectile. The signal processing circuit amplifies the detected pulse and prepares it for data processing.

The sensor is a single loop inductance coil which has been manufactured from a printed circuit board and mounted on the front end of the gun tube. The sensor coil is an electronic component of a radio frequency oscillator circuit. Figure 2 shows a cross-sectional view of the sensor coil assembly which is rigidly attached to the muzzle. This configuration was used for the M68 tank gun to mount the sensor on the muzzle without

drilling holes into the gun tube. Naturally, several other arrangements are possible. In the case of the 75mm smoothbore ARES gun, for example, we screwed the sensor coil assembly onto the muzzle, replacing the muzzle brake. For the 40mm smoothbore cannon, we bolted the front collar directly to the tube. Currently, we are in the process of embedding the sensor coils in a ceramic layer which is sprayed onto the muzzle face, thus minimizing the parasitic weight which could adversely affect tube vibration. Probably this approach may be the most appropriate one for field deployment to monitor the muzzle velocity of large and medium caliber gun systems.

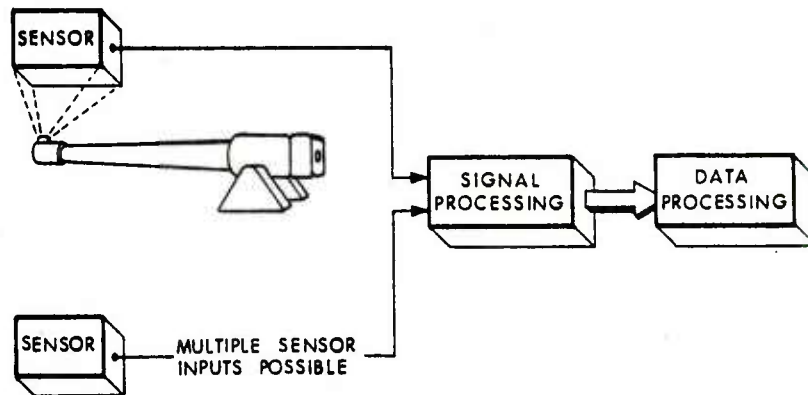

Figure 1. Basic Block Diagram of the Muzzle Velocity Measurement System

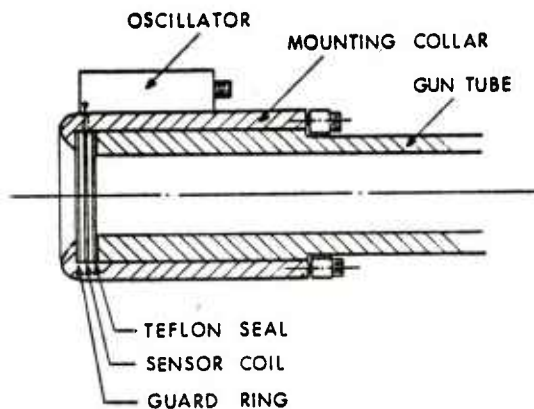

Figure 2. Cross-Sectional View of Sensor Coil Assembly Rigidly Attached to the Muzzle

An expanded view of the sensor coil arrangement is shown in Figure 3. Its components are the guard ring, sensor coil, and teflon seal.

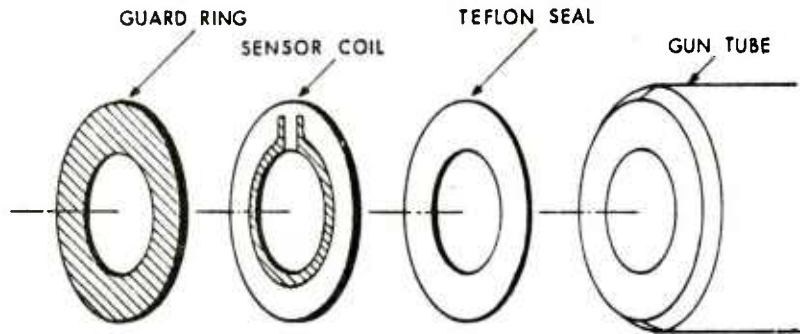

Figure 3. Sensor Coil Arrangement

The sensor coil consists of an inductance coil etched on a single clad printed circuit board. The inductance coil is insulated and separated from the muzzle face by the thickness of the board. A second ring consisting of an unetched single clad circuit board forms a shield (guard ring) and is mounted in front of the sensor coil. Both pieces of circuit board are bonded with epoxy to the front face of the collar and securely held to the muzzle by the mounting collar. To prevent high pressure gas from leaking between the muzzle face and the sensor coil ring, a teflon seal had to be inserted. The rest of the oscillator circuit is housed in a small box mounted on the collar assembly.

Electronically, the oscillator is a conventional Hartley-type oscillator. A schematic diagram of the most recent version of the radio frequency oscillator will be presented later when we discuss its application to the 40mm gun. The utilization of this Hartley-type oscillator for monitoring the projectile exit from the muzzle is based on the recording and evaluation of changes in the electric current of the oscillator which are caused by the interaction of the electromagnetic field of the inductance coil with the transient in-bore environment consisting of the moving projectile and the gas flow which surrounds it. Electronically, this coupling causes an impedance transformation between the active device and its load. Generally, the load may be due to

- the electromagnetic field induced in the projectile surface by the electromagnetic field of the oscillator (eddy currents),

- the change of the dielectric constant and the permeability of the fluid dynamic medium enclosed by the active inductance coil,
- the electric current produced by the flow of the ionized gases,
- the relative motion between the active inductance coil and the metallic mount surfaces, causing a change in the inductive coupling,
- increase of the electron density at the muzzle face, and
- changes in the coil diameter due to pressure loading.

Probably, there are other contributions. Since we are primarily interested in monitoring the projectile exit from the muzzle and, specifically, in determining the muzzle velocity, we would like to suppress all contributions but the first one. The physical process which underlies the first source can be described as follows: the varying electromagnetic field radiated from the active inductance coil produces localized eddy currents in the metallic surface of the projectile when it moves through the coil. The eddy currents, in turn, generate an electromagnetic field which couples back into the active inductance coil. The closer the metallic shell of the projectile is to the inductance coil, the stronger is the induced secondary field and the effect of its recoupling to the inductance coil. The variation in the oscillator impedance causes an increase or decrease of the operating frequency of the oscillator which can be recorded. This frequency modulation was the basis for a measurement device developed by Mr. G. Schultze at ISL¹. However, with the proper selection of oscillator circuit parameters, the change in impedance can be kept such that the frequency shift is minimized and the amplitude modulation is maximized for obtaining the signature of the projectile exit. This technique of amplitude modulation was selected by Mr. J. Q. Schmidt². It provided a simple and inexpensive means of proving the validity of the concept. The pro and con of frequency modulation versus amplitude modulation, however, still needs to be thoroughly examined to optimally exploit this technique for the characterization of projectile launch.

Apart from the initial development efforts which go back to the mid 1970's, we have used the radio frequency oscillator velocimeter on three different cannon systems. We encountered difficulties with each one. We have learned from them and improved the technique constantly. We believe that we have now debugged the instrumentation so that it can be readily adapted to any gun system. Let us now describe our

¹G. Schultze, "Telemetrische V₀-Messungen", Colloquium on Ballistic Measurement Techniques; held at the Institut Franco-Allemand De Recherches De Saint-Louis, 6 and 7 June 1973; ISL Report 14/73.

²J. Q. Schmidt, "A Radio Frequency Oscillator Technique for Measuring Projectile Muzzle Velocity", USARRADCOM, Ballistic Research Laboratory, Aberdeen Proving Ground, MD; Technical Report ARBRL-TR-02158, April 1979. (AD #B038926L)

experience with this instrumentation as it was applied to the three different gun systems.

IV. APPLICATION OF THE RADIO FREQUENCY OSCILLATOR VELOCIMETER

We gained our first true experience when we used the radio frequency oscillator velocimeter as an integral part of the 105mm M68 tank cannon firing program (fall and winter 1977) in which we investigated the causes of the erratic flight of the M392 projectile. In this investigation, we used the output pulse from the oscillator to provide an accurate muzzle exit time, monitor projectile integrity, determine the projectile velocity, and trigger and control auxiliary equipment. Before we conducted the firing program, we checked out the velocimeter instrumentation in the laboratory by moving representative projectiles through the active inductance coil attached to a hollow steel cylinder. The output waveforms obtained are shown in Figure 4.

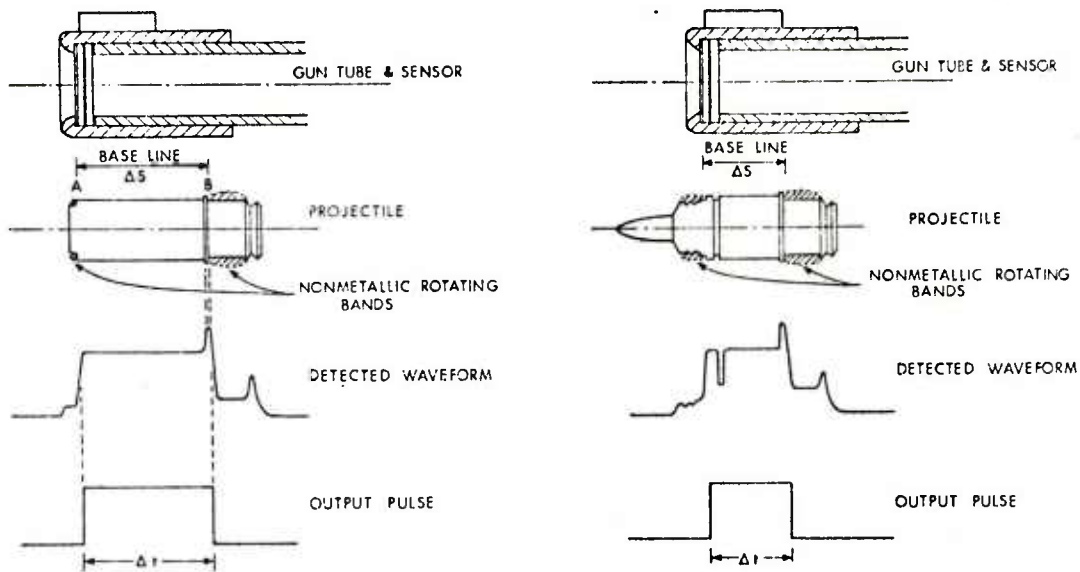

Figure 4. Output Waveforms of a 105mm Proof Slug and an M392 Projectile

Since the amplitude of the oscillator current is modulated as a function of the contour of the metallic shell of the projectile, any discontinuity in the projectile contour can be chosen as a geometric reference point. By correlating the passage time of the reference points with their spatial displacements, one can determine the muzzle exit velocity of the projectile

$$v = \Delta s / \Delta t,$$

where Δs is the projectile reference length and Δt its passage time through the inductance coil.

When we actually fired the proof slug, the recorded output waveforms were similar to those obtained during the laboratory simulation (Figure 5).

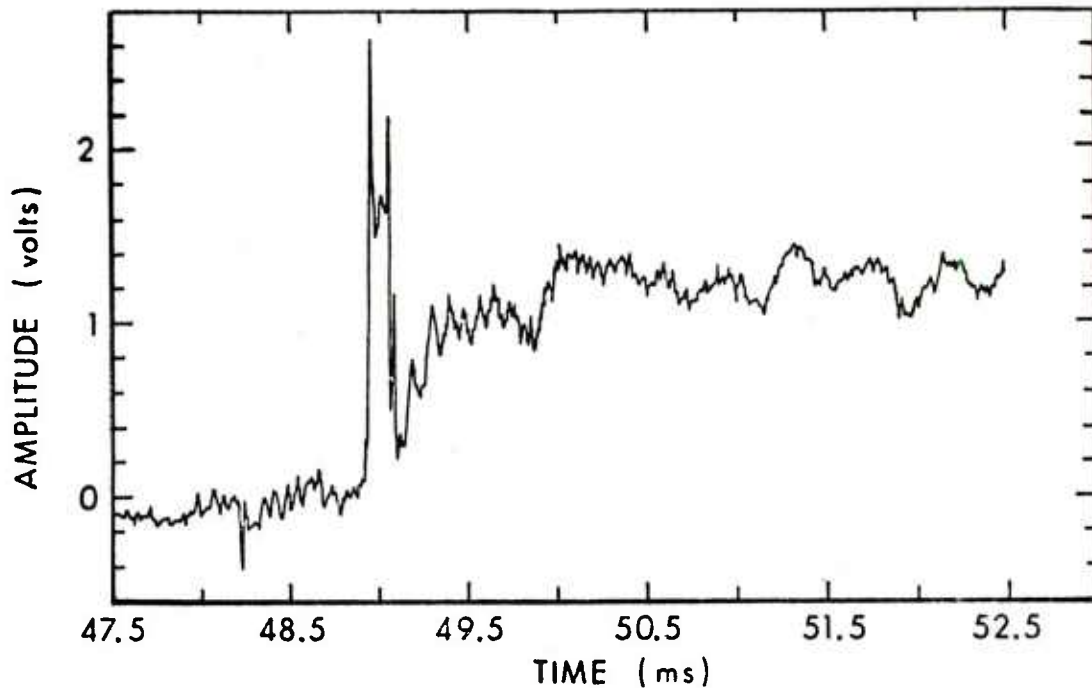

Figure 5. Example of the Signature of the Gas Flow and Projectile Motion Through the Inductance Coil

However, the signal base was no longer constant. It had been modified by the contribution of other physical processes. In addition, we observed that most rounds exited the muzzle cocked, which changed the signal profile (Figure 6). This impeded a reproducible electronic velocity determination in real time. Therefore, we analyzed the signals manually to obtain estimates of the muzzle exit velocity, v , for the fired rounds. We compared these values with velocities, v_M , which we had obtained from microwave interferometry recordings immediately after projectile emergence from the muzzle blast. Generally, the velocities from the radio frequency oscillator instrumentation were 1 to 18 m/sec higher. The estimated error in our relatively crude analysis was ± 10 m/sec or less than 0.7%.

The error

$$\delta v/v = \delta s/\Delta s + \delta t/\Delta t$$

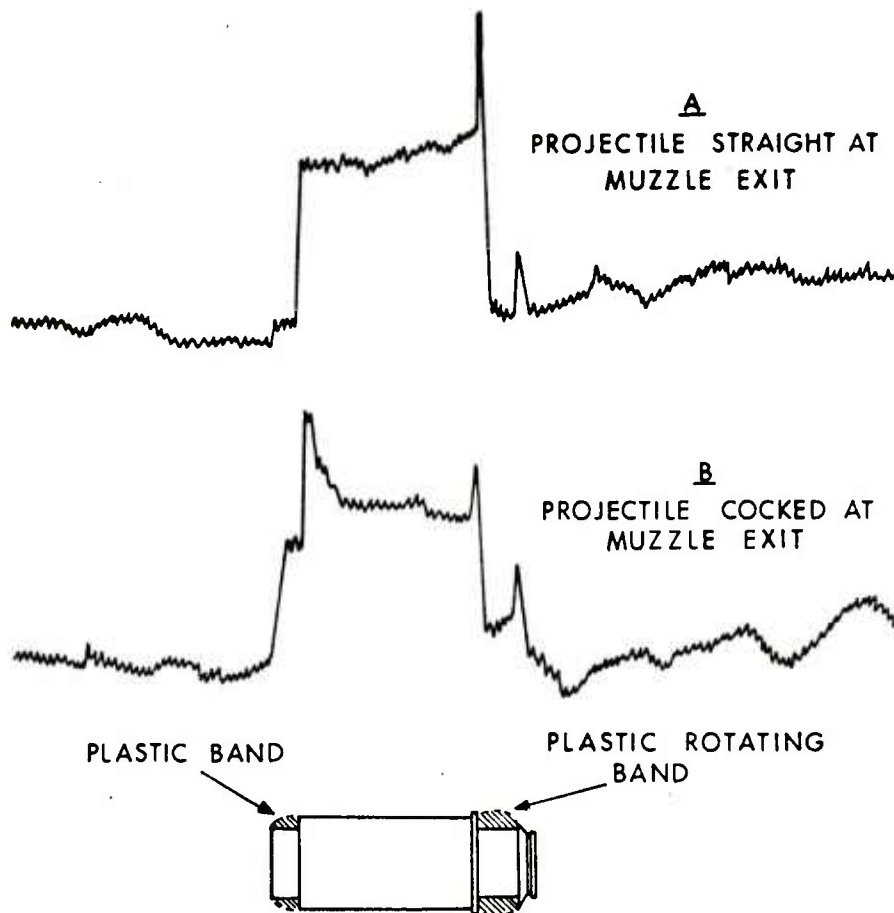

Figure 6. Comparison of 105mm Proof Slugs Exiting a Gun Tube Aligned and Misaligned

mainly was due to the difficulties in associating the proper time points with the passage of the reference length, Δs . The two velocities are related by

$$v = v_R + (v_M - \Delta v) ,$$

where v_R is the recoil velocity of the cannon, and Δv is the velocity which the projectile acquires during its trajectory through the muzzle blast. Using the mean of the velocity differences, $\overline{v - v_M}$, we obtain

$$\overline{v - v_M} = \overline{v_R} - \overline{\Delta v} = 9.2 \text{ m/sec.}$$

For some rounds we recorded the recoil velocity of the cannon. We found that the recoil velocity was about 12 m/sec, resulting in a velocity difference

$$\overline{\Delta v} = \overline{v_R} - \overline{v_{VM}} = 2.8 \text{ m/sec.}$$

This value has the right sign and order of magnitude. Therefore, we initiated the development of a computerized analysis program with the aim to determine more accurately from the signals the time points which are associated with the passage of the reference points and to extract certain characteristic parameters of the total time series.

Firing the M392 projectiles, we encountered difficulties in determining their muzzle velocities from the recorded signals. Figures 7a and 7b show representative examples of the output waveform.

We were surprised by the magnitude of the signal amplitude associated with the passage of the sabot bucket. It was so large that the contour of the sabot did not reveal itself as well as in the case of the proof slug, making it extremely difficult to determine the time points which are associated with the passage of discontinuities in the projectile

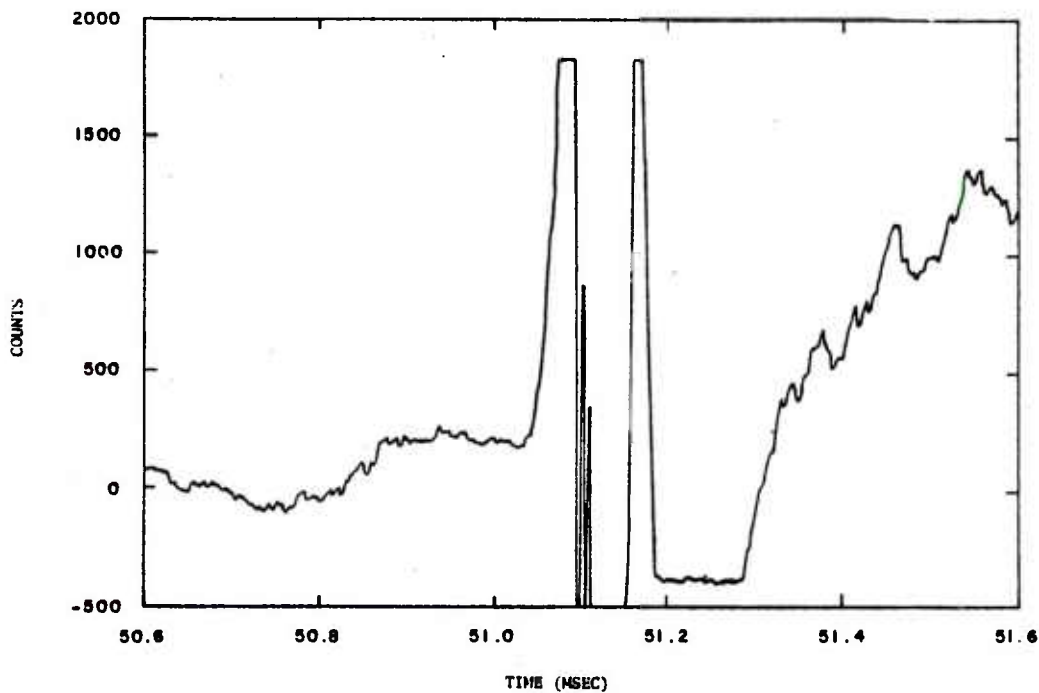

Figure 7a. Example of a Signature for the M392 Projectile

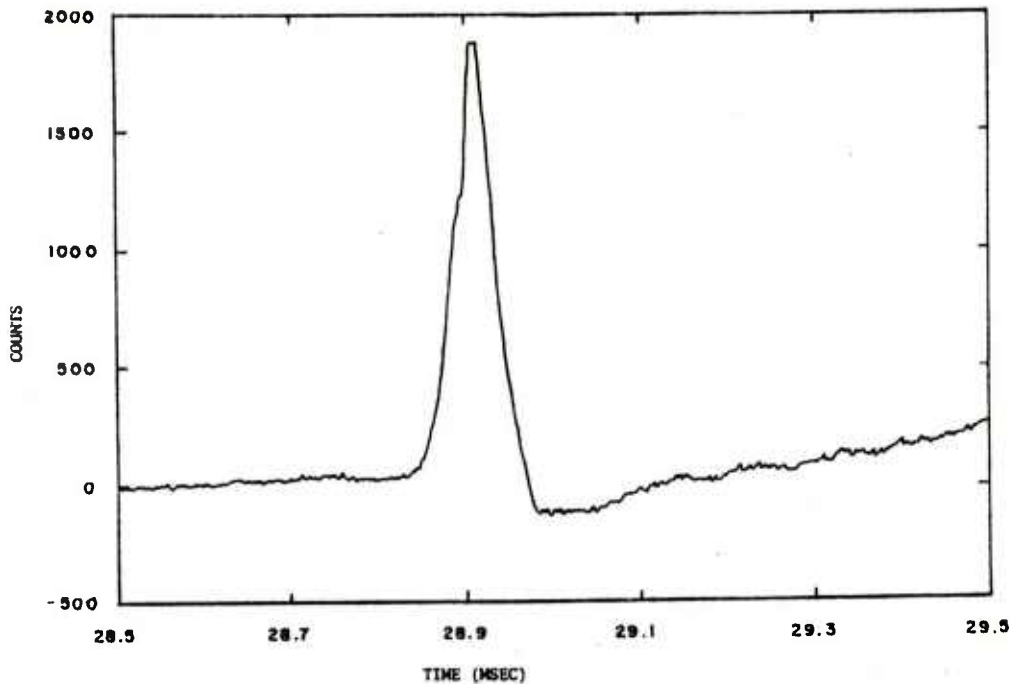

Figure 7b. Example of a Signature for the M392 Projectile

contour without an elaborate curve-fitting and pattern recognition procedure. In addition, the signals occasionally exceeded the range of the amplifier and the recording equipment, causing a temporary signal blackout. To avoid this type of trouble, we decided to employ nonlinear signal amplification in an active feedback mechanism instead of the linear signal amplification.

This nonlinear signal amplification was then incorporated into the electronic circuitry of the radio frequency oscillator velocimeter built for the 75mm smoothbore ARES gun system[†]. In this test, the sensor coil assembly was screwed onto the muzzle. To permit real time velocity measurement, the signal wave generated in the signal processing electronics was directly fed into a time counter. The time series of the raw signal and the square wave were also recorded on analog magnetic tape for a more detailed analysis at a later date. A representative time series of the first six rounds fired through the sensor coil assembly is shown in Figure 8. We observe a ramp like signal rise, followed by an abrupt drop and lowering of the baseline containing the velocity pulse of interest. The signal (Figure 9) outlines very well the actual contour of the projectile. It yields a reference time $\Delta t = 55.5 \pm 0.5$ μ sec and a muzzle exit velocity $v = 989 \pm 12$ m/sec, compared to $\Delta t = 57.3$ μ sec and $v = 958$ m/sec as obtained from the square wave pulse. The

[†]This system features a "soft-recoil" mode of operation.

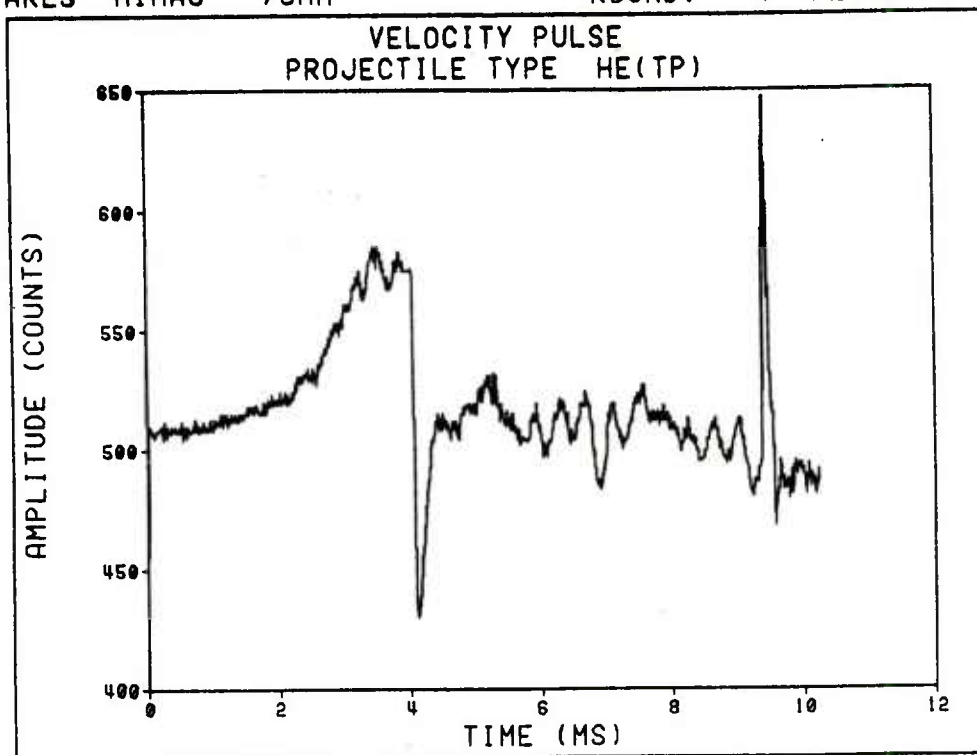

Figure 8. Time Series for the 75mm HE(TP) Projectile, Rd. No. 4

reference length of this projectile was quite short, $\Delta s = 54.9 \pm .25\text{mm}$. The first velocity compares favorably with the velocity $v = 987\text{ m/sec}$ obtained from velocity coils set up down range. The square wave velocities of the first six rounds were scattered within 3% about the velocities obtained from the raw signals. Because of the magnitude of the ramp signal, adjustment of the triggering level for the square wave pulse was critical and affected its duration.

To achieve a more reliable reference time for the real time velocity measurement, we had to reduce the height of the ramp. By studying the coil mounting arrangement and carrying out some laboratory experiments, we were able to pinpoint the source of the ramp: the screw-on mounting arrangement allowed a relative motion between the active inductance coil and the metallic surfaces which sandwiched it. During the ramp phase the muzzle was apparently moving forward into the muzzle device which was held back by inertia, thus decreasing the relative distance and increasing the strength of coupling. When the muzzle face started abruptly moving backward due to the arrival of stress waves associated with the recoil of the cannon, the separation distance increased, causing

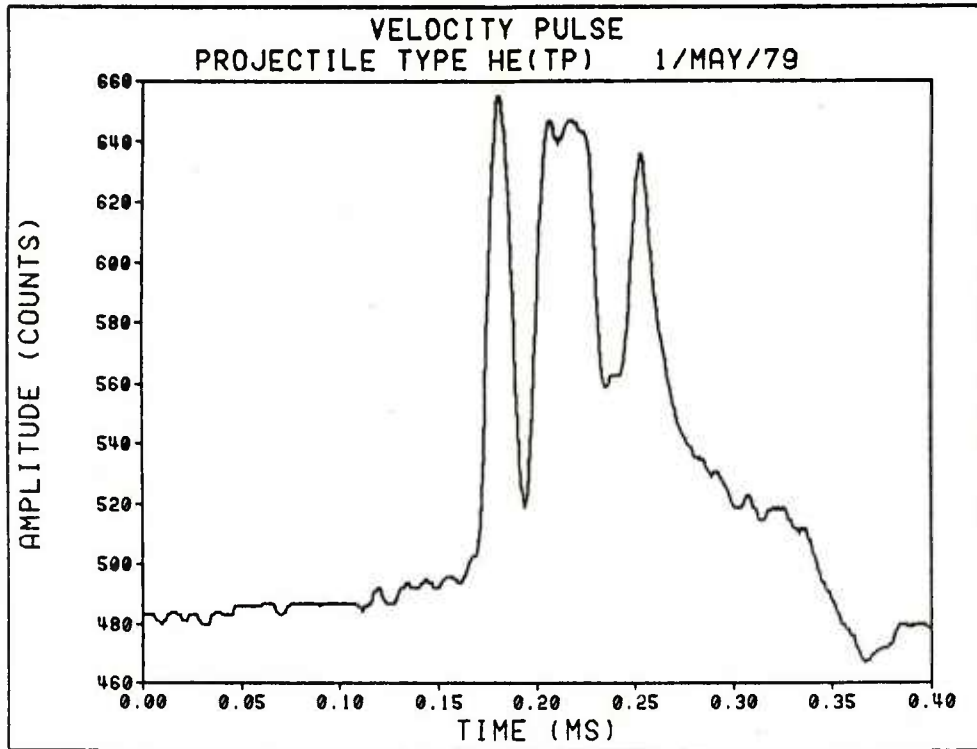

Figure 9. Recorded Profile for the 75mm HE(TP) Projectile, Rd. No. 4

a sudden decrease of the coupling strength and the observed drop in the signal amplitude. Because the standard deviations of the mean ramp rise time and the mean time duration from the ramp end to the projectile exit are less than 4% for the data ensemble, we can exclude random processes and must look for physical processes characteristic for the early part of the in-bore ballistic cycle as a source. The remedy for reducing the ramp signal was straightforward: tighten up the mounting. This severe mounting effect suggests that the radio frequency oscillator velocimeter could actually be used to monitor wave phenomena in a gun tube, if we design the coil mounting arrangement correspondingly.

When we tightened up the coil mounting, we got an acceptable baseline modulation (Figure 10) yielding a square wave pulse (Figure 11), the time duration of which generally was less than 1% of that obtained by the raw signal (Figure 12). In particular, we obtained for this round having a reference length of 111.9mm:

$\Delta t = 108.6 \pm .6 \mu\text{sec}$,	$v = 1031 \pm 6 \text{ m/sec}$... from the raw signal
$\Delta t = 109.1 \mu\text{sec}$,	$v = 1026 \text{ m/sec}$... from the square wave pulse
	$v = 1031 \text{ m/sec}$... from the velocity coils

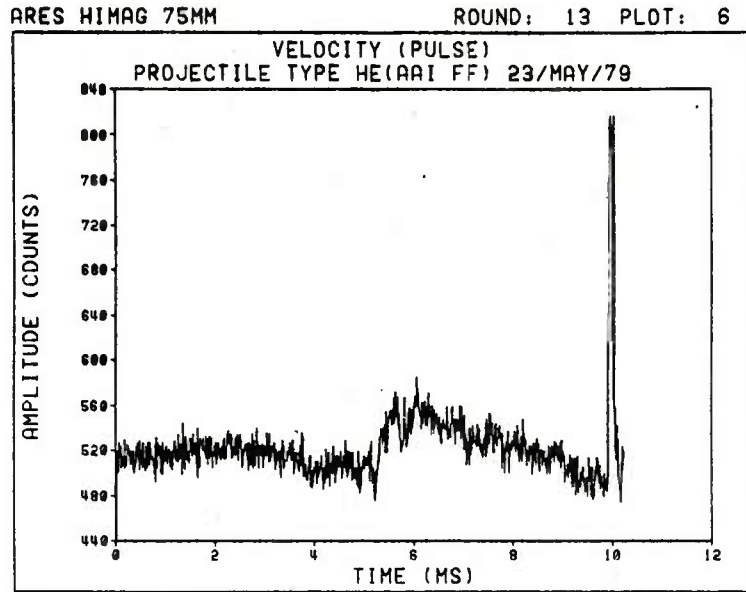

Figure 10. Time Series for the 75mm HE Projectile, Rd. No. 13

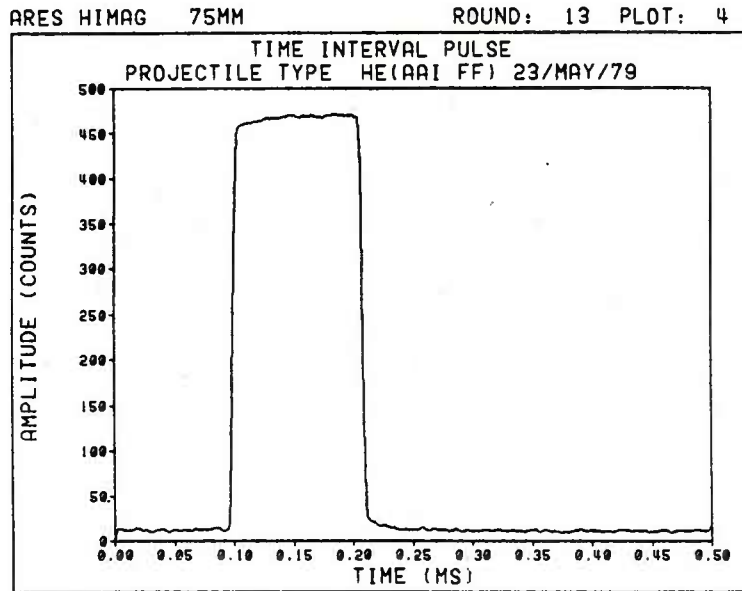

Figure 11. Time interval Pulse (Square Wave) for the 75mm HE Projectile, Rd. No. 13

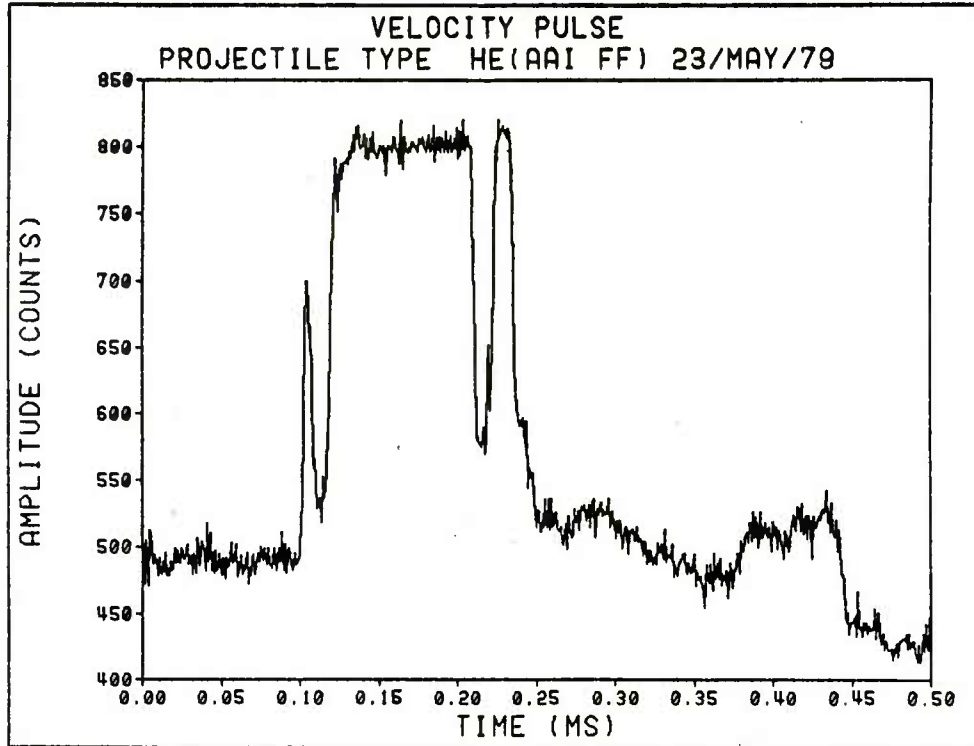

Figure 12. Recorded Profile for the 75mm HE Projectile, Rd. No. 13

In addition to the 105mm and 75mm gun systems, we used the radio frequency oscillator velocimeter technique in a 40mm experimental smooth-bore gun. Most of the recent improvements in reducing unwanted contributions to the signal derive from its application to this gun system. In this firing program, the projectile velocity at muzzle exit varies from 200 to 1800 m/sec, permitting us to evaluate the instrumentation over a broad velocity range.

Break wires and in-bore microwave interferometry were also used to record the projectile velocities, providing a means for comparing results. A rigorous comparison has not been carried out yet, partly because the projectile reference length may be modified during the projectile seating process in the chamber. Besides the almost standard 60 Hz ground wire problems which took considerable time to eliminate, we encountered only a relatively small baseline modulation which could be traced back to the passage of the compressed gas in front of and behind the projectile. An illustration is given in Figure 13.

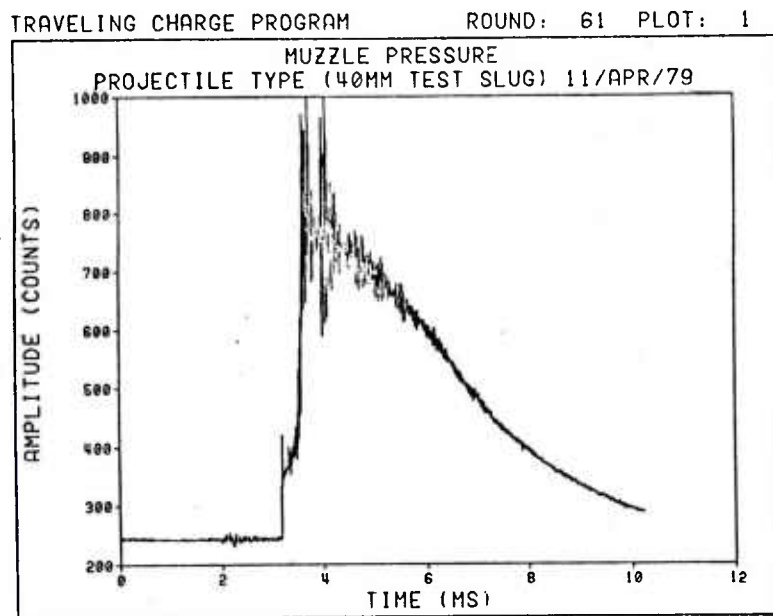
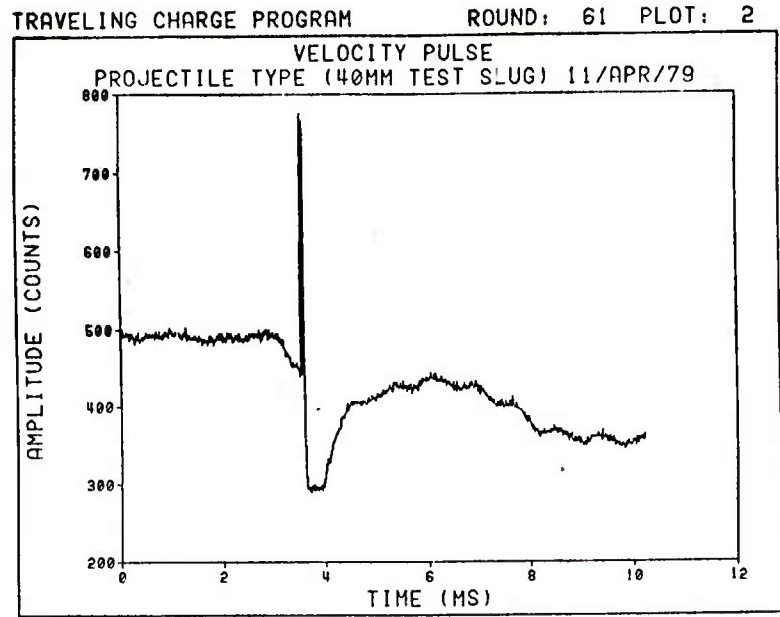

Figure 13. Velocity Pulse and Muzzle Pressure for 40mm Test Slug, Rd. No. 61

We included the pressure record taken at 25 mm from the muzzle for purposes of comparison. Analysis shows that the dip in the baseline in front of the velocity pulse is connected with the arrival and passage of the shockwave and the compressed gases behind it. We have also observed this baseline modulation in the data sets for the other two gun systems; however, not as clearly as in these firings. The velocity pulse for this round is given in Figure 14.

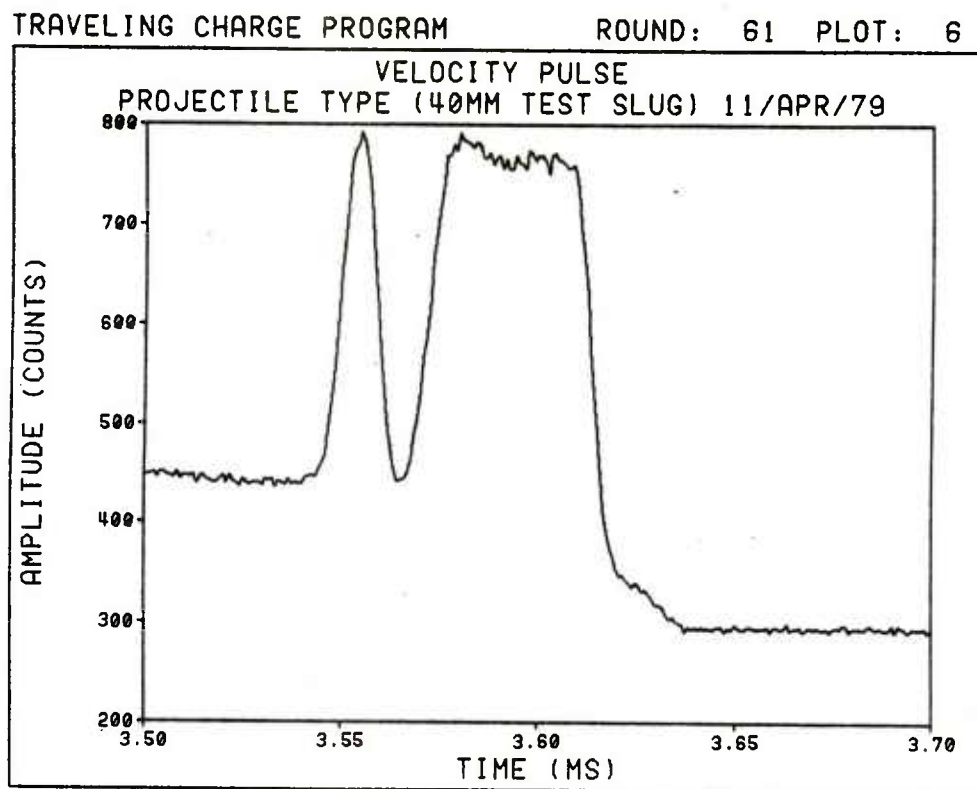

Figure 14. Recorded Profile for the 40mm Test Slug, Rd. No. 61

For purposes of comparison we obtained the following velocities for this round:

$v=1341 \pm 10$ m/sec ... from the raw pulse,
 $v=1333$ m/sec ... from the square wave pulse, and
 $v=1369$ m/sec ... from the break wire.

In our opinion, the baseline modulation associated with the exiting gas flow is mainly due to an electric current in the muzzle face. It is indirectly produced by the higher mobility of the free electrons compared to the relatively low mobility of the positive ions in the hot gas flow,

which permits an accumulation of negative charge in the conducting cannon. Since all major baseline modulations which are adverse to real time velocity measurements derive either from a relative motion between the active inductance coil and the muzzle face or from the charge up of the muzzle face, we concluded that we should be able to eliminate them by using two active inductance coils in one plane and differencing the signals. In that way we should eliminate or, at least, considerably reduce contributions picked up by both inductance coils concurrently and produce a signal which correlates only to the loads induced by the medium passing through the inner inductance coil. We replaced the one coil device by a double one and, indeed, we obtained the desired noise-reduced baseline (Figure 15). The dip associated with the gas passage is reduced to a negligible effect. The velocity pulse now stands out clearly on a level baseline (Figure 16).

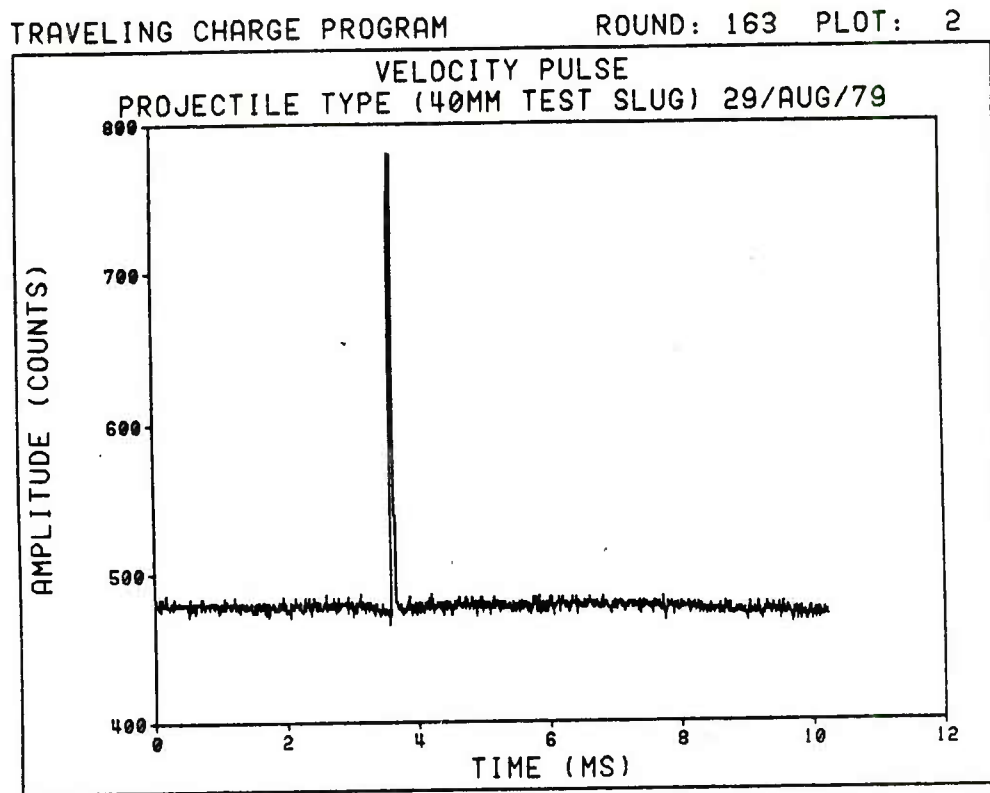

Figure 15. Time Series for the 40mm Test Slug, Rd. No. 163

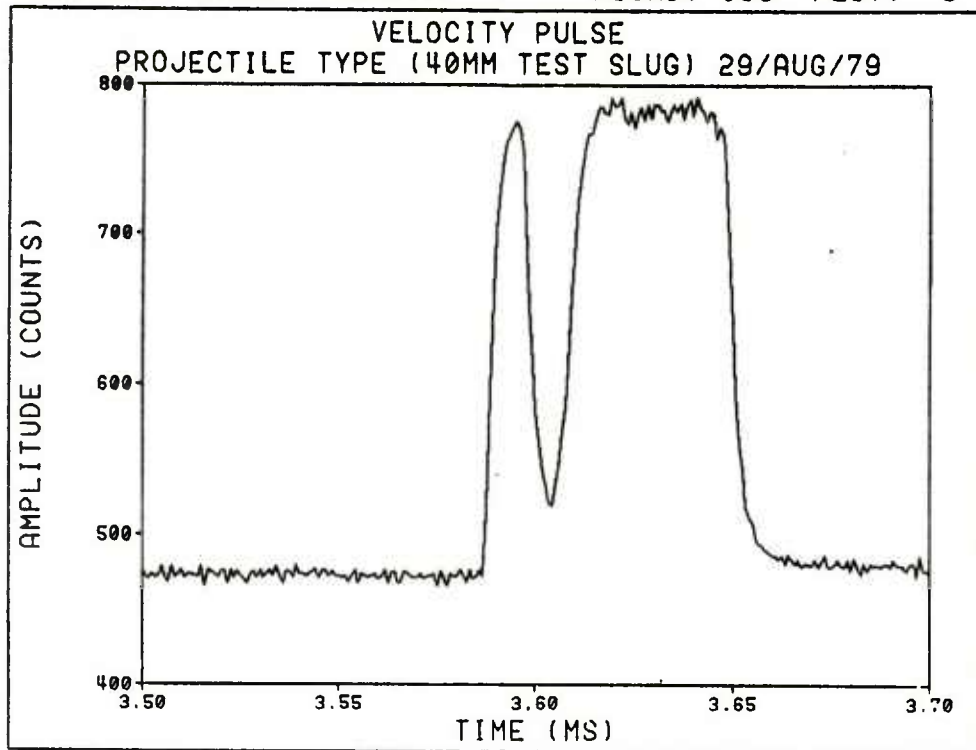

Figure 16. Recorded Profile for the 40mm Test Slug, Rd. No. 163

We obtained the following velocities for round No. 163, for instance:

$v=1386 \pm 10$ m/sec ... from the raw signal,
 $v=1391$ m/sec ... from the square wave pulse, and
 $v=1427$ m/sec ... from the in-bore microwave interferometry.

V. RADIO FREQUENCY OSCILLATOR VELOCIMETER, DOUBLE INDUCTANCE COIL DESIGN

The new design consists of two single turn, concentric inductance coils as shown in Figure 17. The double sensor coils are mounted in the same manner as the original single sensor coil. The outputs of the two coils are fed to a low gain differential amplifier which cancels all extraneous signals common to both coils. The schematic of the differential sensor arrangement is shown in Figure 18. Although the primary purpose of the differential sensor circuitry is the cancellation of all signals extraneous to the velocity pulse, the new design provides several other advantages over the original design:

- cancellation of the static DC offset resulting in improved stability when DC is coupled to the signal processor,

- decrease in sensitivity to temperature variation since any change in the oscillator frequency or amplitude is reduced by the differential action of the amplifier, and
- cancellation/suppression of effects due to the relative motion between the active inductance coils and the muzzle face and the electric charge up of the muzzle face.

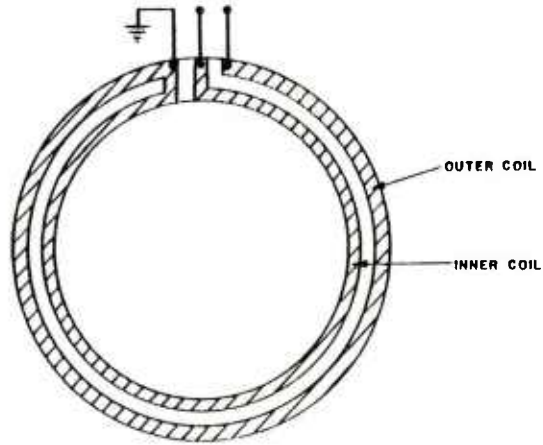

Figure 17. Double Inductance Coil Design

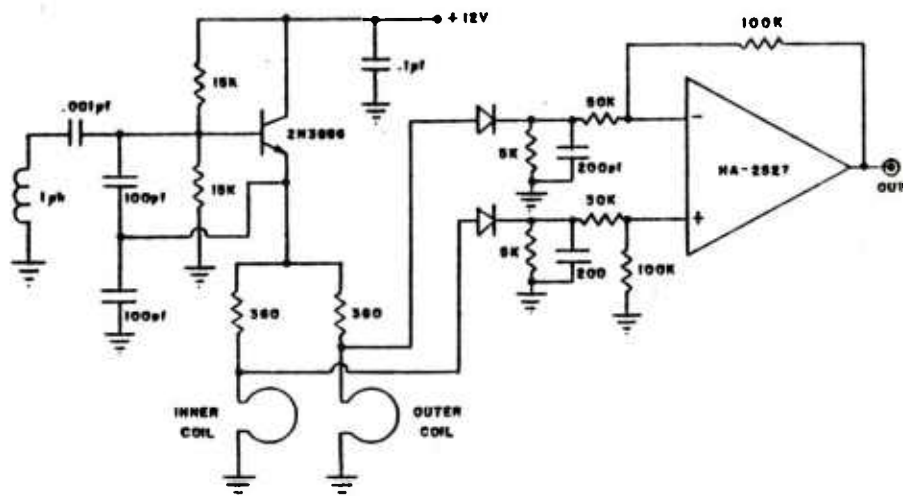

Figure 18. Schematic Diagram of the Differential Sensor Circuitry

Experience with earlier radio frequency oscillator velocimeter designs suggested several changes in the basic configuration of the signal processor. We found that under certain test firing conditions an isolation amplifier was necessary to eliminate ground loops and, thereby, reduce the common 60 Hz interference. When the gun is positioned more than 50 m from the signal processor, however, the isolation amplifier may not reduce the 60 Hz interference sufficiently. Since the isolation amplifiers available had a maximum bandwidth of 100 kHz, a unity gain differential amplifier was designed into the circuitry to provide the necessary bandwidth and isolation. The amplifier providing the gain for the signal is physically located at the muzzle. This configuration guarantees the necessary reduction in noise and 60 Hz interference and provides the clean signals which are required for the generation of the square wave pulse.

To prevent the firing voltage or other transient signals from prematurely triggering the logic circuits in the time interval counter, a delay feature was incorporated in the signal processor. The delay circuit can be controlled either by a sequence timer stage in the firing sequence or by a built-in delay circuit activated by the firing voltage.

The original signal processing circuits were designed for projectiles with contour discontinuities such that the output pulse, when processed, had only a single or double-pulse signature. In addition, the projectile velocity was limited to a velocity band. To provide the ability to measure the velocity of projectiles with complex contour discontinuities over a velocity range from 175 m/sec up to about 1800 m/sec or higher, the logic part of the signal processor was redesigned. The block diagram of the logic circuit currently being used is shown in Figure 19.

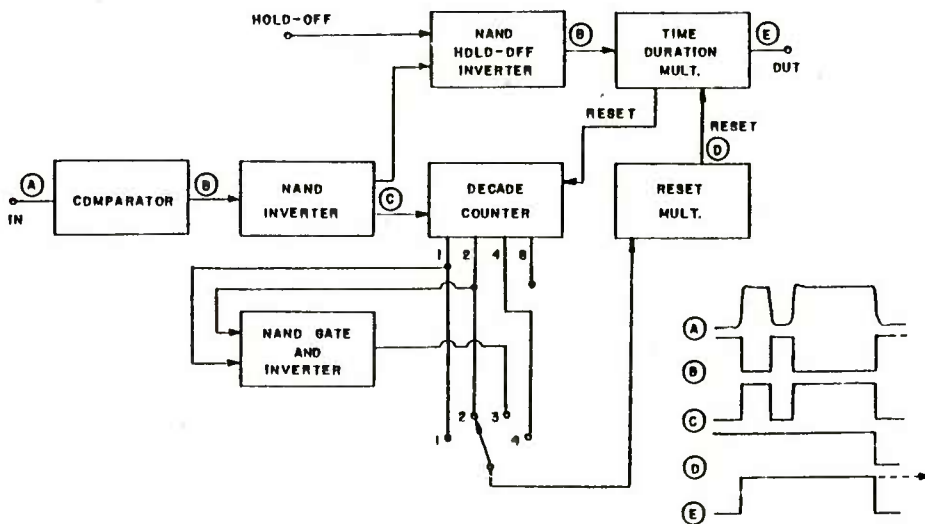

Figure 19. Block Diagram of the Logic Circuit for the Signal Processor

The logic circuit is quite simple, requiring only four integrated circuits. Also shown are the waveforms at various points for a projectile signature consisting of two major pulses. The output of the isolation amplifier (A) is fed to a comparator which changes logic states at approximately 50% of peak amplitude of the signal. Trimming the triggering level provides a means of calibrating the time duration measurements slightly. The output signal of the comparator (B) is an inverted replica of the incoming one with much faster rise and fall times. It is fed to a NAND gate functioning as an inverter. One output signal from the inverter (C) goes into a decade counter, the other one is coupled through a second NAND gate which acts as a delay circuit to prevent false triggering. In the process, the signal is inverted back to its original polarity (B). The leading edge of the first downward pulse triggers the time interval multivibrator. This monostable multivibrator automatically stays on for about 600 μ sec, if not reset. Its output holds the decade counter reset at zero until the delay circuit is released and the time interval multivibrator is triggered. When the signal becomes negative, the decade counter is initiated. Each pulse counted is fed to the four output leads in BCD form. Depending on the selector switch setting, up to four pulses can be integrated into a time interval pulse. For example, let's assume the selector switch is set for two pulses. When the second pulse is counted, the output signal on line "2" triggers the "RESET" multivibrator. The output of the "RESET" multivibrator (D) resets the time interval multivibrator to terminate the pulse and provide the final time interval pulse for its measurement. The time interval pulse (E) is a single pulse. Its time duration is the same as the passage time of the projectile at the sensor. The BCD outputs provide a "1,2,4,8" count. In order to count three pulses, the output signals from "1" and "2" are fed to a NAND gate and inverter, thus providing a three count. One could extend the procedure to cover several individual pulses through the use of another IC.

The time interval pulse is used to gate a 10 MHz clock. The number of clock pulses corresponding to its duration is counted and displayed on a four digit LED readout. The time duration count is also fed to a digital printer which records the time of passage. Automatic reset signals are provided from the printer to record rapid fire as in the case of the 75mm gun system. The time duration pulse is also amplified to provide a reliable trigger pulse for the instrumentation to monitor projectile parameters immediately after launch. For instance, we used this pulse to control the timing of the x-ray pulses for the 40mm traveling charge program.

In addition to the real time velocity measurement, we record the original time series and the square wave pulse on an analog magnetic tape for a more detailed analysis at a later date.

VI. SUMMARY

There are other arrangements and configurations of coils which could be applied. Some of these are currently being studied to determine which would be the most applicable to axial and angular displacement measurements.

There is one area which has been addressed only on the side until now but should be followed up: the radio frequency oscillator technique could also be utilized to retrieve projectile-cannon interface processes. To what extent, we don't know yet.

Based on our latest experience, we believe that the radio frequency oscillator velocimeter has been refined to a point where it can be reliably applied to the real time measurement of the projectile velocity at muzzle exit in the field as well as in the laboratory.

The radio frequency oscillator velocimeter has several advantages over any one of the other velocity measurement systems previously described:

- It provides real time velocity measurements,
- It is inexpensive,
- It does not require projectiles to be modified
- There are no restrictions on azimuth and elevation firing angles,
- It can be used on rapid-fire weapon systems,
- It requires only a minimal amount of calibration,
- It can be directly integrated into computer programs for online data processing, and
- It can be easily coupled to auxiliary circuitry such as x-ray units.

REFERENCES

1. G. Schultze, "Telemetrische V_0 -Messungen", Colloquium on Ballistic Measurement Techniques; held at the Institut Franco-Allemand De Recherches De Saint-Louis, 6 and 7 June 1973; ISL Report 14/73.
2. J. Q. Schmidt, "A Radio Frequency Oscillator Technique for Measuring Projectile Muzzle Velocity", USARRADCOM, Ballistic Research Laboratory, Aberdeen Proving Ground, MD; Technical Report ARBRL-TR-02158, April 1979. (AD #B038926L)

DISTRIBUTION LIST

<u>No. of</u> <u>Copies</u>	<u>Organization</u>	<u>No. of</u> <u>Copies</u>	<u>Organization</u>
12	Commander Defense Technical Info Center ATTN: DDC-DDA Cameron Station Alexandria, VA 22314	8	Commander US Army Armament Research and Development Command ATTN: DRDAR-LCA DRDAR-LCW DRDAR-LCE DRDAR-LCM DRDAR-LCN DRDAR-LCS DRDAR-LCU DRDAR-LC Dover, NJ 07801
2	Director Defense Advanced Research Projects Agency 1400 Wilson Boulevard Arlington, VA 22209		
1	Director Defense Nuclear Agency Washington, DC 20305	6	Commander US Army Armament Research and Development Command ATTN: DRDAR-SC DRDAR-SA DRDAR-SCM DRDAR-SCS DRDAR-SCA DRDAR-SCF Dover, NJ 07801
1	Commander US Army BMD Advanced Technology Center ATTN: BMDATC-M P. O. Box 1500 Huntsville, AL 35807		
1	Commander US Army Materiel Development and Readiness Command ATTN: DRCDMD-ST 5001 Eisenhower Avenue Alexandria, VA 22333	6	Commander US Army Armament Research and Development Command ATTN: DRDAR-LCA, Dr. H. Fair Mr. L. Rosendorf Dr. S. H. Chu Mr. B. Knutelski DRDAR-LCR-R, E. H. Moore DRDAR-LCW, Mr. R. Wrenn Dover, NJ 07801
5	Commander US Army Armament Research and Development Command ATTN: DRDAR-TD DRDAR-TDA DRDAR-TDS DRDAR-TSS (2 cys) Dover, NJ 07801	7	Commander US Army Armament Research and Development Command ATTN: DRDAR-SCA, C. J. McGee S. Goldstein F. P. Puzycski E. Jeeter DRDAR-SCF, B. Brodman M. J. Schmitz L. Berman Dover, NJ 07801

DISTRIBUTION LIST

<u>No. of Copies</u>	<u>Organization</u>	<u>No. of Copies</u>	<u>Organization</u>
2	Commander US Army ARRADCOM Systems Evaluation Office ATTN: DRDAR-SE Dover, NJ 07801	2	Commander US Army Aviation Research and Development Command ATTN: DRSAV-E P. O. Box 209 St. Louis, MO 63166
2	Commander US Army ARRADCOM Product Assurance Directorate ATTN: DRDAR-QA Dover, NJ 07801	1	Director US Army Air Mobility Research and Development Laboratory Ames Research Center Moffett Field, CA 94035
1	Commander US Army ARRADCOM Army Fuze Mgt Project Office ATTN: DRDAR-FU Dover, NJ 07801	2	Director US Army Research and Technology Labs (AVRADCOM) Ames Research Center Moffett Field, CA 94035
2	Commander US Army ARRADCOM ATTN: Dev. Proj. Ofc. for Selected Ammunition DRDAR-DP Dover, NJ 07801	1	Commander US Army Communications Rsch and Development Command Fort Monmouth, NJ 07703
1	Commander US Army Armament Materiel Readiness Command ATTN: DRSAR-LEP-L, Tech Lib Rock Island, IL 61299	1	Commander US Army Communications Rsch and Development Command ATTN: DRDCO-PPA-SA Fort Monmouth, NJ 07703
2	Director US Army ARRADCOM Benet Weapons Laboratory ATTN: DRDAR-LCB Watervliet, NY 12189	1	Commander US Army Electronics Research and Development Command Technical Support Activity ATTN: DELSD-L Fort Monmouth, NJ 07703
4	Commander US Army ARRADCOM Benet Weapons Laboratory ATTN: DRDAR-LCB-TL DRDAR-LCB, Dr. J. Zweig Dr. T. Davidson Dr. T. Simkins Watervliet, NY 12189	1	Commander US Army Harry Diamond Labs 2800 Powder Mill Road Adelphi, MD 20783

DISTRIBUTION LIST

<u>No. of Copies</u>	<u>Organization</u>	<u>No. of Copies</u>	<u>Organization</u>
1	Commander US Army Harry Diamond Labs ATTN: DELHD-I-RT, H.D.Curchack 2800 Powder Mill Road Adelphi, MD 20783	2	Project Manager Nuclear Munitions ATTN: DRCPM-NUC Dover, NJ 07801
1	Commander US Army Missile Command ATTN: DRSMI-R Redstone Arsenal, AL 35809	2	Project Manager Tank Main Armament Systems ATTN: DRCPM-TMA Dover, NJ 07801
1	Commander US Army Missile Command ATTN: DRSMI-RBL Redstone Arsenal, AL 35809	1	Product Manager for 30mm Ammo ATTN: DRCPM-AAH-30mm Dover, NJ 07801
1	Commander US Army Missile Command ATTN: DRSMI-YDL Redstone Arsenal, AL 35809	2	Produce Manager M110E2 Weapon System, DARCOM ATTN: DRCPM-M110E2 Rock Island, IL 61299
2	Commander US Army Mobility Equipment Research & Development Cmd Fort Belvoir, VA 22060	4	Director US Army Mechanics and Materials Research Center ATTN: Director (3 cys) DRXMR-ATL (1 cy) Watertown, MA 02172
2	Commander US Army Tank Automotive Research & Development Cmd ATTN: DRDTA-UL Technical Director Warren, MI 48090	3	Commander US Army Research Office ATTN: Tech Director Engineering Division Metallurgy & Materials Division Research Triangle Park NC 27009
2	Project Manager Division Air Defense Gun ATTN: DRCPM-ADG Dover, NJ 07801	2	Director US Army TRADOC Systems Analysis Activity ATTN: ATAA-SL, Tech Lib Director White Sands Missile Range NM 88002
2	Project Manager Cannon Artillery Wpns Sys ATTN: DRCPM-CAWS Dover, NJ 07801		

DISTRIBUTION LIST

<u>No. of Copies</u>	<u>Organization</u>	<u>No. of Copies</u>	<u>Organization</u>
1	Commander Naval Air Systems Command Washington, DC 20360	3	Commander Naval Surface Weapons Center ATTN: Code E-31, R.C. Reed M. T. Walchak Code V-14, W.M.Hinckley Silver Spring, MD 20910
1	Commander Naval Sea Systems Command Washington, DC 20362	2	Commander Naval Surface Weapons Center Silver Spring, MD 20910
1	Commander Naval Sea Systems Command ATTN: SEA-03513, L. Pasiuk Washington, DC 20362	2	Commander Naval Weapons Center China Lake, CA 93555
2	Commander Naval Ordnance Systems Command Washington, DC 20360	3	Commander Naval Weapons Center ATTN: J. O'Malley D. Potts R. G. Sewell China Lake, CA 93555
2	Commander Naval Ship Research and Development Command Bethesda, MD 20084	1	Commander Naval Research Laboratory Washington, DC 20375
1	Commander Naval Air Development Center Johnsville Warminster, PA 18974	1	Superintendent Naval Postgraduate School ATTN: Dir of Lib Monterey, CA 93940
1	Commander Naval Missile Center Point Mugu, CA 95041	1	Commander Naval Ordnance Station Indian Head, MD 20640
2	Commander Naval Surface Weapons Center Dahlgren, VA 22448	2	Commander Naval Ordnance Station ATTN: Code 5034, Ch, Irish Jr. T. C. Smith Indian Head, MD 20640
4	Commander Naval Surface Weapons Center ATTN: Code G-33, T.N.Tschirn Code N-43, J.J.Yagla L. Anderson G. Soo Hoo Dahlgren, VA 22448	2	AFATL Eglin AFB, FL 32542

DISTRIBUTION LIST

<u>No. of Copies</u>	<u>Organization</u>	<u>No. of Copies</u>	<u>Organization</u>
3	AFATL (DLA, W. Dittrich; DLD, D. Davis; DLDL) Eglin AFB, FL 32542	1	Director National Aeronautics and Space Administration Manned Spacecraft Center ATTN: Lib Houston, TX 77058
2	AFWL Kirtland AFB, NM 87117		
2	ASD Wright-Patterson AFB, OH 45433		<u>Aberdeen Proving Ground</u>
2	AFML Wright-Patterson AFB, OH 45433		Dir, USAMSA ATTN: DRXSY-D DRXSY-G, E. Christman DRXSY-OSD, H. Burke DRXSY-G, R.C. Conroy DRXSY-LM, J.C.C. Fine DRXSY-MP, H. Cohen
1	Director Los Alamos Scientific Lab Los Alamos, NM 87544		
1	Director Lawrence Livermore Laboratory Livermore, CA 94550		Dir, USAHEL ATTN: A. H. Eckles, III
1	Headquarters National Aeronautics and Space Administration Washington, DC 20546		Cdr, USATECOM ATTN: DRSTE-TO-F
2	Director National Aeronautics and Space Administration Langley Research Center Langley Station Hampton, VA 23365		Dir, USACSL, Bldg. E3516, EA ATTN: DRDAR-CLB-PA DRDAR-CL DRDAR-CLB DRDAR-CLD DRDAR-CLY DRDAR-CLN

USER EVALUATION OF REPORT

Please take a few minutes to answer the questions below; tear out this sheet, fold as indicated, staple or tape closed, and place in the mail. Your comments will provide us with information for improving future reports.

1. BRL Report Number _____

2. Does this report satisfy a need? (Comment on purpose, related project, or other area of interest for which report will be used.)

3. How, specifically, is the report being used? (Information source, design data or procedure, management procedure, source of ideas, etc.) _____

4. Has the information in this report led to any quantitative savings as far as man-hours/contract dollars saved, operating costs avoided, efficiencies achieved, etc.? If so, please elaborate.

5. General Comments (Indicate what you think should be changed to make this report and future reports of this type more responsive to your needs, more usable, improve readability, etc.) _____

6. If you would like to be contacted by the personnel who prepared this report to raise specific questions or discuss the topic, please fill in the following information.

Name: _____

Telephone Number: _____

Organization Address: _____

