

AD-A101 691

MIAMI UNIV CORAL GABLES FL REMOTE SENSING LAB

F/G 4/2

INTENSE RAINFALL RATES AND THEIR EFFECTS ON MICROWAVE ATTENUATI—ETC(U)

APR 81 H W HISER, H V SENN

DAAG29-77-6-0227

UNCLASSIFIED

Y6995

ARO-14631.1-65

NL

[ or ]  
AD-A101 691



END  
DATE  
FILMED  
8-81  
DTIC

**LEVEL II**

ARO 14631:1-AS ✓



INTENSE RAINFALL RATES AND THEIR EFFECTS ON MICROWAVE ATTENUATION

FINAL REPORT

H.W. HISER AND H.V. SENN

APRIL 1981

U. S. ARMY RESEARCH OFFICE

GRANT NO. DAAG29-77-G-0227

*Naval*  
REMOTE SENSING LABORATORY ✓  
MECHANICAL ENGINEERING DEPARTMENT  
SCHOOL OF ENGINEERING AND ARCHITECTURE  
UNIVERSITY OF MIAMI  
CORAL GABLES, FLORIDA 33124

**DTIC**  
**ELECTE**  
JUL 21 1981  
**S D**  
**D**

APPROVED FOR PUBLIC RELEASE;  
DISTRIBUTION UNLIMITED.

AD A101691

DTIC FILE COPY

81 7 17 101

THE VIEW, OPINIONS, AND/OR FINDINGS CONTAINED IN THIS REPORT ARE  
THOSE OF THE AUTHOR(S) AND SHOULD NOT BE CONSTRUED AS AN OFFICIAL  
DEPARTMENT OF THE ARMY POSITION, POLICY, OR DECISION, UNLESS SO  
DESIGNATED BY OTHER DOCUMENTATION.

UNCLASSIFIED

SECURITY CLASSIFICATION OF THIS PAGE (When Data Entered)

REPORT DOCUMENTATION PAGE		READ INSTRUCTIONS BEFORE COMPLETING FORM
1. REPORT NUMBER Final Report	2. GOVT ACCESSION NO. HD-A101691	3. RECIPIENT'S CATALOG NUMBER
4. TITLE (and Subtitle) INTENSE RAINFALL RATES AND THEIR EFFECTS ON MICROWAVE ATTENUATION		5. TYPE OF REPORT & PERIOD COVERED Final Report 26 Sep 77 - 25 Sep 80
7. AUTHOR(s) H.W. Hiser and H.V. Senn		6. PERFORMING ORG. REPORT NUMBER Y6995
9. PERFORMING ORGANIZATION NAME AND ADDRESS Remote Sensing Laboratory Mechanical Engineering Department School of Engineering and Architecture University of Miami, Coral Gables, FL 33124		8. CONTRACT OR GRANT NUMBER(s) Grant No. DAAG29-77-G-0227
11. CONTROLLING OFFICE NAME AND ADDRESS U. S. Army Research Office Post Office Box 12211 Research Triangle Park, NC 27709		10. PROGRAM ELEMENT, PROJECT, TASK AREA & WORK UNIT NUMBERS 76A-7309; P611102.H5700-2583; S31124; 11161102BH57-01 P-14631-GS/7
14. MONITORING AGENCY NAME & ADDRESS (if different from Controlling Office)		12. REPORT DATE April 1981
		13. NUMBER OF PAGES 105
		15. SECURITY CLASS. (of this Report) Unclassified
		15a. DECLASSIFICATION/DOWNGRADING SCHEDULE
16. DISTRIBUTION STATEMENT (of this Report)  Approved for public release; distribution unlimited.		
17. DISTRIBUTION STATEMENT (of the abstract entered in Block 20, if different from Report)  NA		
18. SUPPLEMENTARY NOTES The view, opinions, and/or findings contained in this report are those of the author(s) and should not be construed as an official Department of the Army position, policy, or decision, unless so designated by other documentation.		
19. KEY WORDS (Continue on reverse side if necessary and identify by block number) Microwave Attenuation Rain Attenuation Microwave Propagation Propagation through Rain Satellite Communications Communication Satellites		
20. ABSTRACT (Continue on reverse side if necessary and identify by block number) Rainfall records at the University of Miami and at many other places throughout Florida were examined for the years 1960-1978 inclusive to determine maximum rates and durations to be expected. Radar was sometimes used to determine the dimensions of rain cells. Hourly rainfall totals greater than 2 inches occurred most frequently in central and south Florida. Recording raingages showed that most of the hours with more than 2 inches of rain were convective storms in which the total amount fell in 20 to 30 minutes giving rates of 102 mm per hour and greater.		

DD FORM 1 JAN 73 1473

EDITION OF 1 NOV 65 IS OBSOLETE

UNCLASSIFIED

412446

SECURITY CLASSIFICATION OF THIS PAGE (When Data Entered)

20. ABSTRACT (Continued)

A large intense rainstorm on 25 April 1979 produced an extreme rate of 584 mm per hour that lasted for 15 minutes at the Miami Airport. The calculated attenuation at 20GHZ was 63.6 db per mile for a total of 382 db on a slant path 6 miles in length. Several rain cells in this storm produced calculated attenuation totals in excess of 50 db along slant paths at 20GHZ for periods of one-half hour. Typically, the size of rain cells and general orientation and movement of this storm suggested a space diversity of 20GHZ antennas on the order of 5 to 6 miles for high antenna elevation angles and more spacing for low angles.

The report includes a bibliography and a paper describing a digital radar calibration system for rainfall monitoring.

PROBLEM STUDIED

This was a study of intense rainfall rates in Florida and their effects on microwave attenuation, especially at radio frequencies above 10GHZ. The increasing need for radio communications, both on the surface and to satellites and spacecraft, requires the operation of channels above 10GHZ which suffer significant attenuation by intense rainfall. Data from raingages and radars were used to obtain as much information as possible in three dimensions in order to calculate attenuation along slant paths to satellites. Worst cases of calculated rainfall attenuation were compared with signal attenuation measurements from satellites at 19GHZ made on the Tampa TRIAD experiment by GTE Sylvania Labs. and the University of South Florida Physics Dept. They used a triangle of space diversity antennas. Size and prevailing directions of movement of intense rain cells were used in our study to suggest a preferred space diversity and orientation of comsat antennas in the Miami area.

Accession For	
NTIS GFA&I	<input checked="" type="checkbox"/>
DTIC TAB	<input type="checkbox"/>
Unannounced	<input type="checkbox"/>
Justification	
By _____	
Distribution/	
Availability Codes	
Dist	Avail and/or Special
A	

**S** DTIC  
ELECTE **D**  
JUL 21 1981  
**D**

## SUMMARY OF RESULTS

Rainfall records at the University of Miami and at many other places throughout Florida were examined for the years 1960-1978 inclusive to determine maximum rates and durations to be expected. Both raingage and radar data were used in a number of cases to determine the area of coverage and duration of the high rainfall rates. Rainfalls of 2.50 to 2.99 and those that exceeded 3.0 inches per hour were experienced throughout Florida, but by far the most cases of these intense rates occurred in central and south Florida, see Appendix 1.

An extremely intense and large rainstorm occurred in south Florida on the morning of 25 April 1979. A study has been made of this storm because it is typical of the worst that are to be expected in south Florida on a long-term basis. The 100-year, 60-minute precipitation for south Florida is 5.0 inches according to NOAA [74], and USWB [75]. The maximum rate recorded in this storm was 5.75 inches in about 15 minutes at Miami International Airport. Figure 1 is a total storm rainfall map prepared by the South Florida Water Management District [76]. Most of this rain fell on the morning of 25 April, Figure 2. The SFWMD classified the northern part of the storm as 1 in 100 years and the portion around Miami airport as 1 in 100 to 1 in 200 years. Probably a satellite communications system with a space diversity of antennas to perform satisfactorily during this rainstorm would also perform satisfactorily 99.99% of the time for all rainstorms in Florida. Although hurricanes are much larger, they do not produce rainfall rates of this magnitude and areal extent at any given time.

Figures 3 and 4 are contoured PPI photographs from the National Hurricane Center/NOAA, WSR-57, 10-cm wavelength, radar located on the University of Miami campus at that time. Figure 3 is at 0953Z and Figure 4 at 1328Z. The range rings are at 25-naut. mile intervals and the center is blanked out electronically to eliminate the ground return echoes near the radar station. Some contours 4 and 5 (46 and 50 dbz) are present to the NNE of Miami in Figure 3. Contours 4 and 6 (46 and 57 dbz) are present in the elongated intense area NNE of Miami in Figure 4. Here the intensity gradient was so steep that contours 3 and 5 are not depicted. The contour sequence is as follows:

<u>Contour</u>	<u>Display</u>	<u>Reflectivity</u>	<u>Approx. Rain Rate</u>
1.	gray	--	<0.1 in/hr.
2.	white	30 dbz	0.1-0.5
3.	black	41 dbz	0.5-1.0
4.	gray	46 dbz	1.0-2.0
5.	white	50 dbz	2.0-5.0
6.	black	57 dbz	>5.0

In Figure 4, the inner contours abruptly change from white to gray and gray to black because of the extreme rainfall rates in this storm.

Figures 5, 6 and 7 contain sketches of precipitation echo contours 2 (dashed), 3 (solid), and 5 (shaded) made from 35-mm film taken on the same radar as Figures 3 and 4. The 50-naut. mile range circle is centered on the University of Miami where the WSR-57 was located. The coastline of Florida is shown along with the locations of recording raingages. Half-hour rainfall totals are plotted at the raingage locations, and the radar contours are drawn for the midpoint of the half-hour interval.

The radar showed the rain cells to be moving from the SSW at about 25 knots. The echo pattern was continuously changing due to this movement and to the growth and decay of rain cells. This at least partly explains why the echo pattern in each figure does not match all the rainfall totals for the half-hour period. Unfortunately, digitized radar data are not available for this storm. It occurred mostly at night and early morning, was not forecast, and the U. of Miami radar digitizer could not be placed in operation in time to gather significant data. The maximum rainfall rate in this storm occurred within the radar ground return and is not depicted by the contours in Figures 3 through 8.

Between 0800 and 0830Z, there was a large area with rain rates of 2 inches per hour or greater in and SSW of Miami, Figure 5, as shown by the recording raingages. The empirical relation between specific attenuation  $Y$  (db/mile) and rainfall rate  $R$  (mm/hr) at 20GHZ, Bradley [77], is:  $Y(\text{db/mile}) = 0.08R^{1.05}$ . For a rain rate of 2 inches or 51 mm per hour this gives 4.97 db attenuation per mile. This attenuation persisted for one-half hour and covered an area at least five miles in extent east-west by ten miles north-south. The radar tops were on the order of 30,000 ft. For comsat antennas located in the northern part of this storm, oriented SW or SE and elevated to 55° or less, the slant path through the storm would have been at least 6 miles in length and resulted in attenuation of at least 30 db for one-half hour.

This calculated attenuation of 30 db is equivalent to the worst case reported on the Tampa TRIAD for 19GHZ on 8 May 1979, Tang, et.al. [4]. At 19GHZ, they reported about 29 db total attenuation with continuous intense rain of approximately 25 mm per hour and antenna elevation angle 56.9 degrees. With 51 mm per hour persisting from 0800 to 0830Z at Miami, it is likely that the total attenuation at 19 or 20 GHZ would have been considerably greater than the 30 db computed by use of the empirical relation. Also, the maximum rain rate reported in this cell was 3.4 inches (86.4 mm) per hour at Homestead Experiment Station about 25 miles southwest of the Miami radar. Location with respect to this core of maximum rain intensity and elevation angle of the antenna would have been major factors. Either of these could have caused the computed total attenuation to increase to at least 50 db.

Between 0930 and 1000Z, Figure 6, rainfall rates of 4 inches or 102 mm per hour occurred over a small area about 5 miles in diameter centered just north of the Miami airport. The airport recording was at a rate of 4.2 inches per hour and other measurements in the area, reference 76, provide information on the areal extent of this rate. By this time, the radar tops of the strongest cells were exceeding 40,000 ft. For comsat antennas located at the north edge of this storm, oriented SW or SE and elevated to 55° or less, the slant path through the storm would have been more than 5 miles in length. Applying

the same empirical equation as was used for Figure 5 at 20GHZ gives 10.28 db attenuation per mile or a total of 51.4 db persisting for one-half hour. This appears to have considerably exceeded any values measured on the Tampa TRIAD experiment.

Figure 7 shows the most intense rainfall rate recorded in the 25 April 79 storm. The 5.75 inches shown at Miami Airport just north of the radar station between 1115 and 1145Z actually fell in 15 minutes, 1130-1145Z, giving a rate of 23 inches (584 mm) per hour persisting for 15 minutes. Another intense rain cell about 40 miles north along the coast produced 4.60 inches (117 mm) per hour and a third cell about 60 miles north produced 4 inches (102 mm) per hour. The WSR-57 radar showed the rain cells at this time to be moving from 210° at 25 knots. The rainfall gradients were very steep and the rain cells appeared to pass almost directly over the respective gages. The speed of movement would give a cell diameter of about 6 miles at Miami Airport and about 12 miles each for the two cells along the coast 40-60 miles north. The radar tops were approximately 40,000 ft.

For Comsat antennas located in the northern portion of the storm cell at Miami Airport, oriented SW or SE and elevated to 55° or less, the slant path through the storm would have been at least 6 miles in length. Applying the same empirical equation as was used for Figure 5 at 20GHZ gives 63.6 db attenuation per mile or a total of 382 db persisting for 15 minutes.

The other two rain cells 40 and 60 miles north of Miami in Figure 7 were less intense but slightly larger than the one at Miami Airport. The attenuation at 20GHZ would have been approximately 11.9 db/mile for one and 10.3 db/mile for the other. For Comsat antennas located in the northern portions of these cells, the slant path would have been about 6 miles in length for high antenna elevation angles of the order of 55 degrees. For lower antenna elevation angles, the slant path would have increased to a maximum length of approximately 12 miles. For the minimum path length of 6 miles, the total attenuation would have been 71.4 db and 61.8 db respectively. These are less spectacular than the Miami Airport storm, but they did persist for one-half hour. Also, they considerably exceeded any values measured on the Tampa TRIAD experiment.

This 25 April 1979 storm was a rare event in one respect because of the extreme rate of 23 inches (584 mm) per hour that occurred at the Miami International Airport. However, experience with the recording raingage at this Laboratory indicates that 6 inches (152 mm) per hour that persists for 20 minutes is not uncommon. Most of the hours with more than 2 inches of rain at Miami shown in Appendix I are cases in which the total amount fell in 20 to 30 minutes giving rates of 4 inches (102 mm) per hour and greater. They are convective type rains that do not last for one hour.

The 25 April 1979 storm is rather typical in regard to the size of the most intense rain cells. It suggests the need for a space diversity on the order of 5 to 6 miles for comsat antennas at 20GHZ operated at high elevation angles of 50 degrees or more. Slightly greater spacing would be better for antennas operated at considerably lower elevation angles. Radar observations

shown that the most severe squall lines and convergence zones in South Florida tend to be oriented in a generally north-south direction. Therefore, an east-west spacing of Comsat antennas is preferred. The azimuth orientation of a Comsat antenna in South Florida will usually be southeast through southwest. This can result in a slant path parallel to or on a bias across the major axis of the squall line or convergence zone. Relatively high antenna elevation angles common to South Florida help to offset this problem of looking along the major axis of the precipitation.

A north-south oriented squall line or convergence zone of this type will typically drift eastward or remain stationary while the individual cells of intense rain move from 200 - 240 degrees as observed by radar. These cells form on the upwind side and dissipate on the downwind side as they traverse the squall line or convergence zone. In an easterly regime during the summer months, the reverse may be true. A line or zone will drift westward or remain stationary while the individual cells move from the southeast. Thus the intense cells may move along the azimuth of the Comsat antenna, but with an east-west space diversity of antennas one of them should begin to break out of the intense rain by the time the other antenna becomes affected.

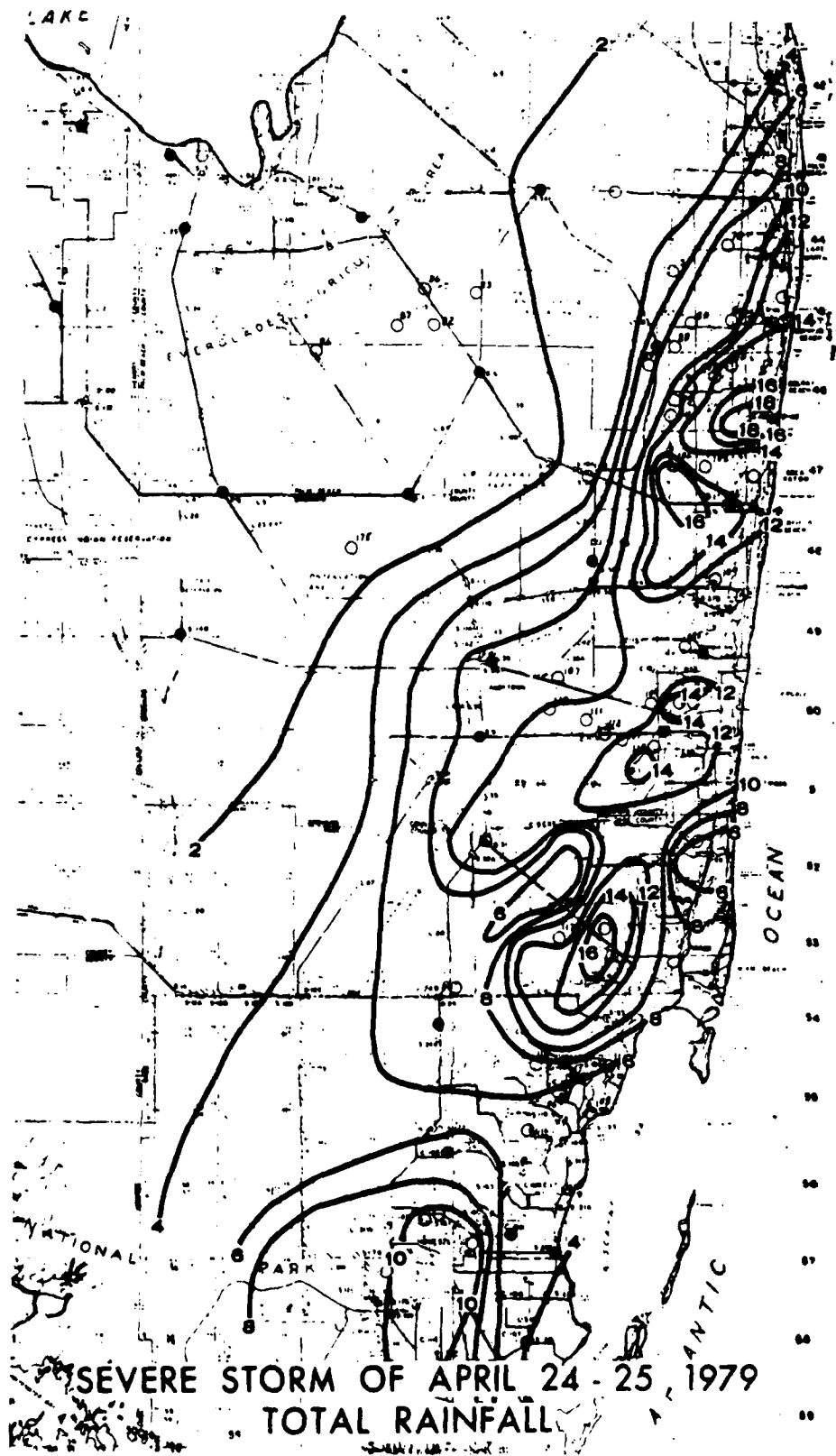
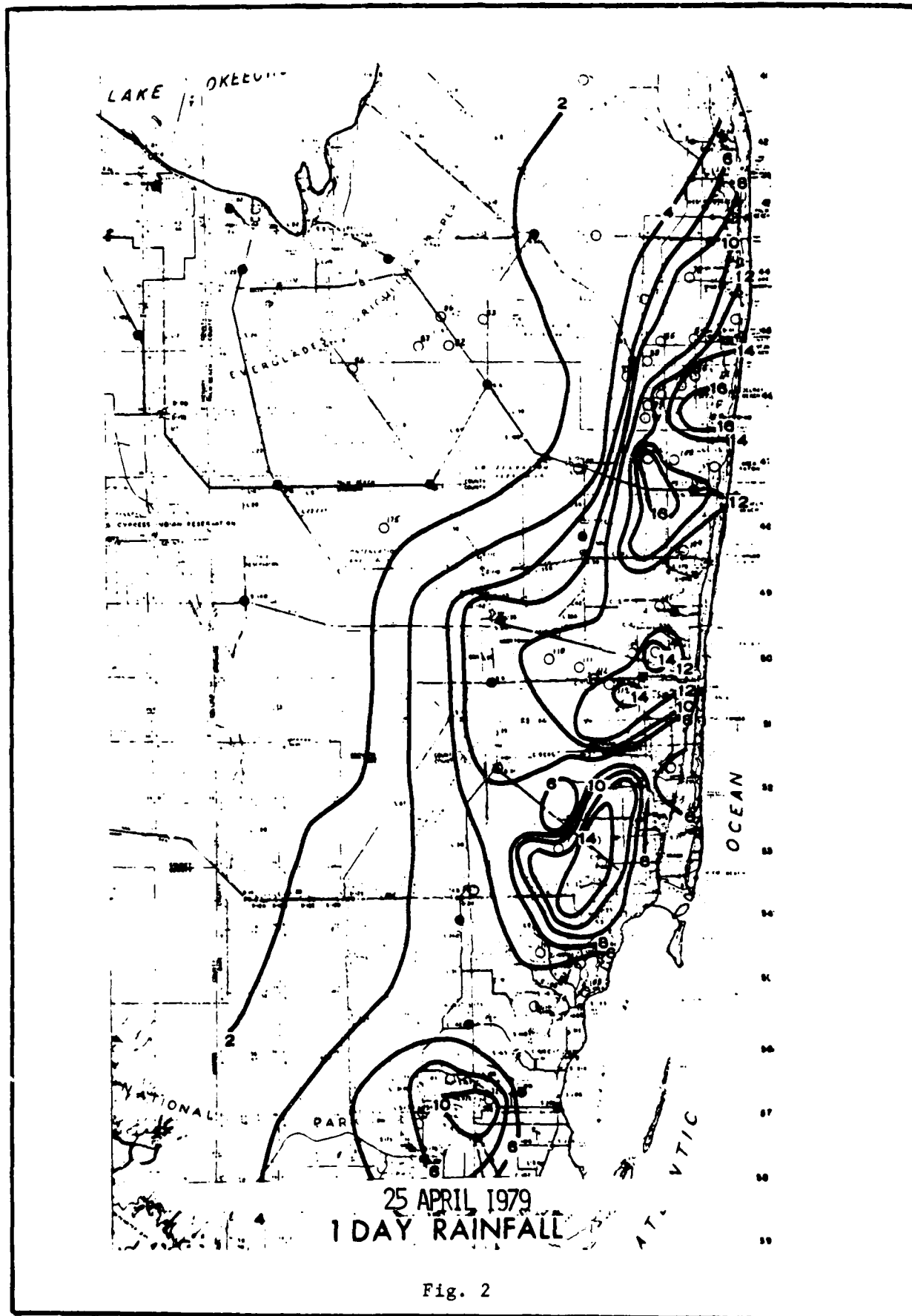

Fig. 1



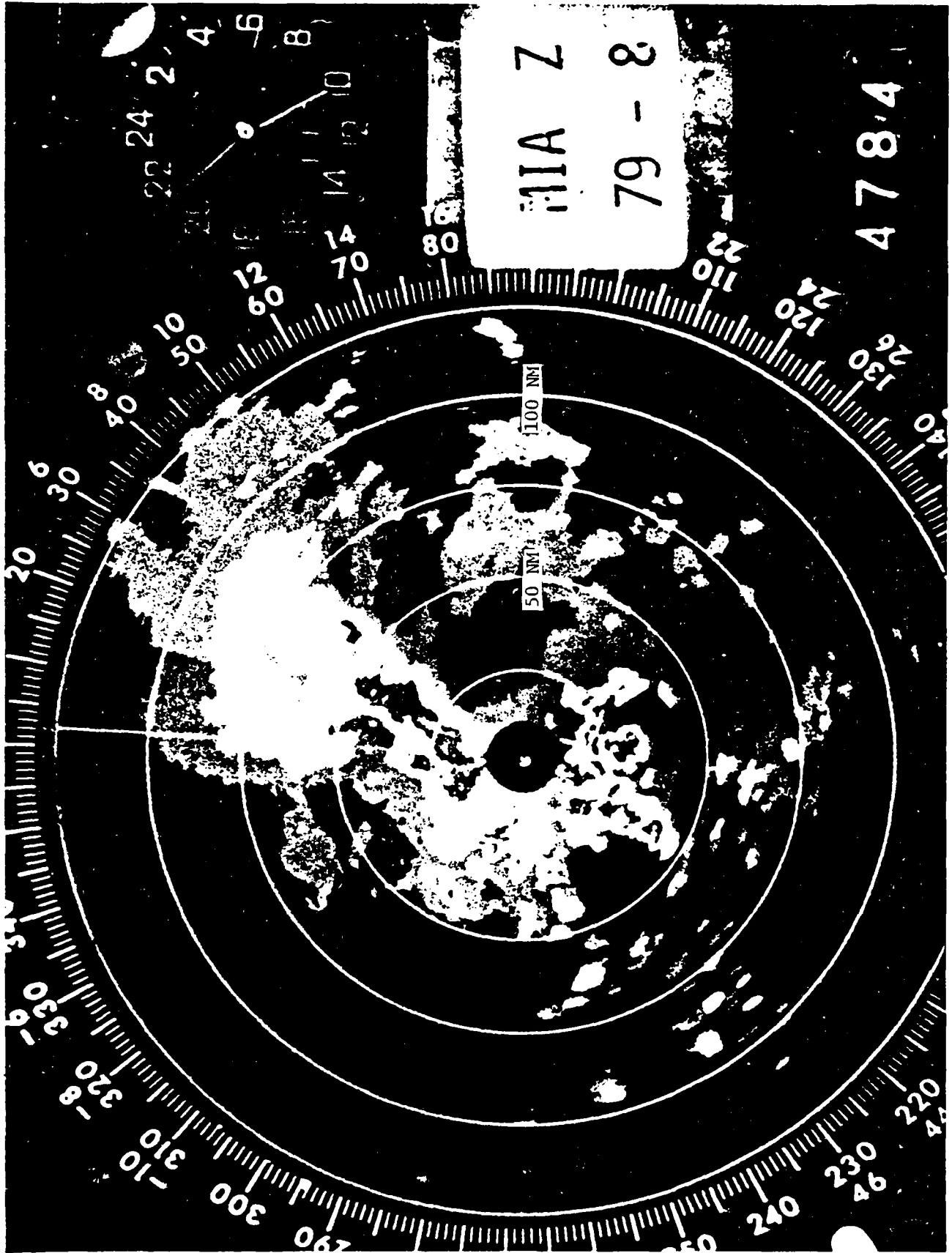

Fig. 3 - WSR-57 Radar at National Hurricane Center on Univ. of Miami Campus, 0953Z, 25 April 79

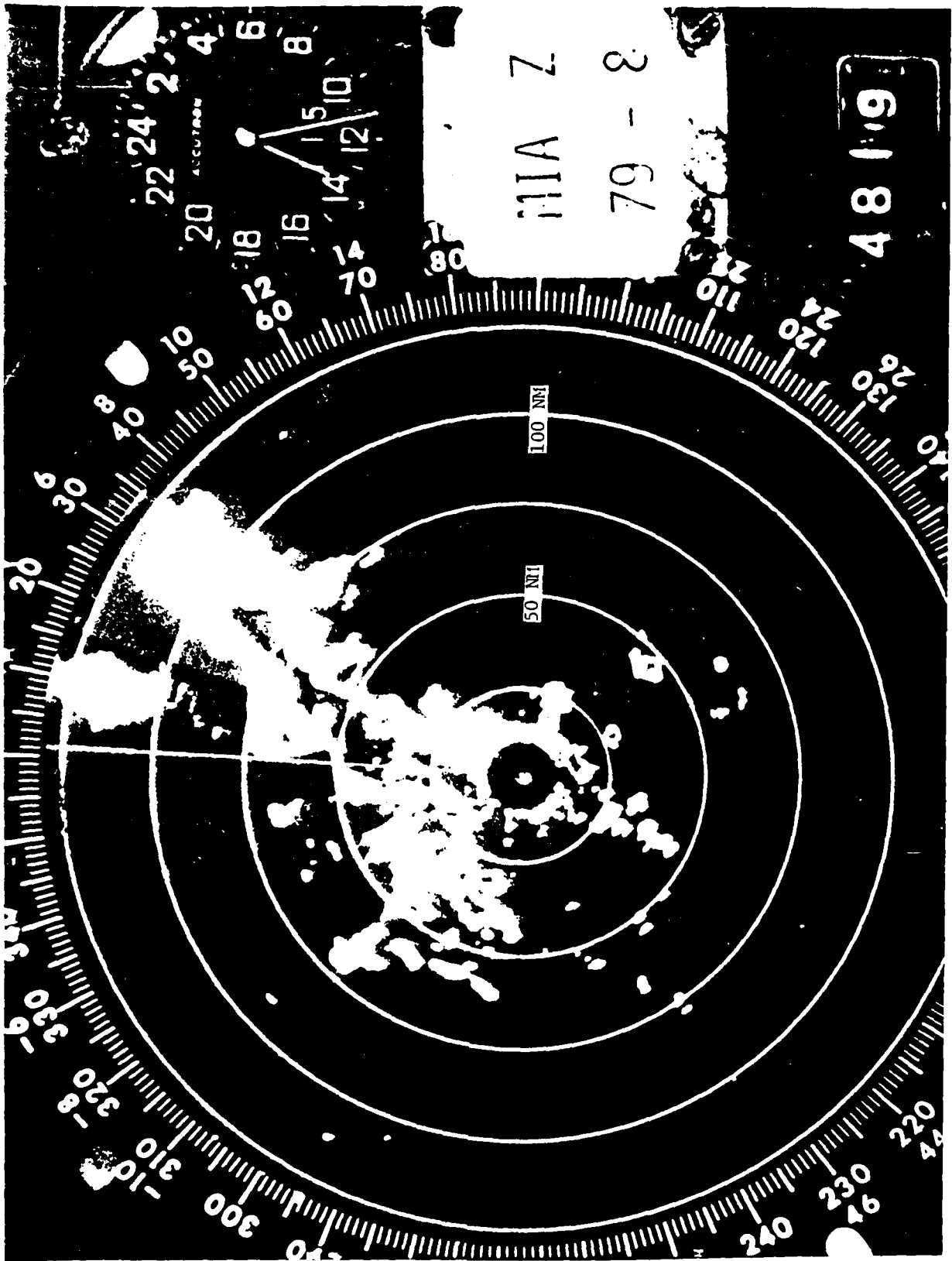
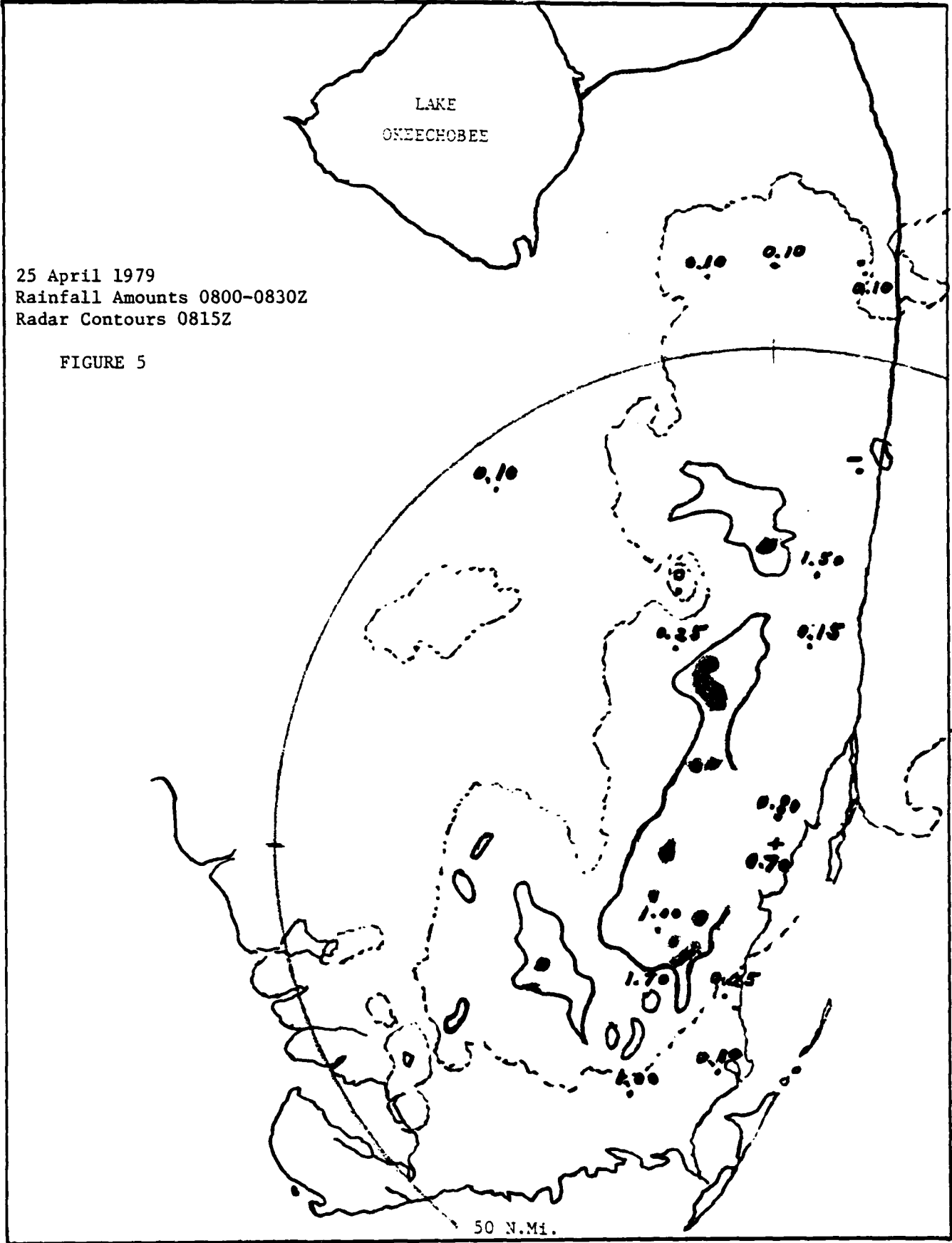
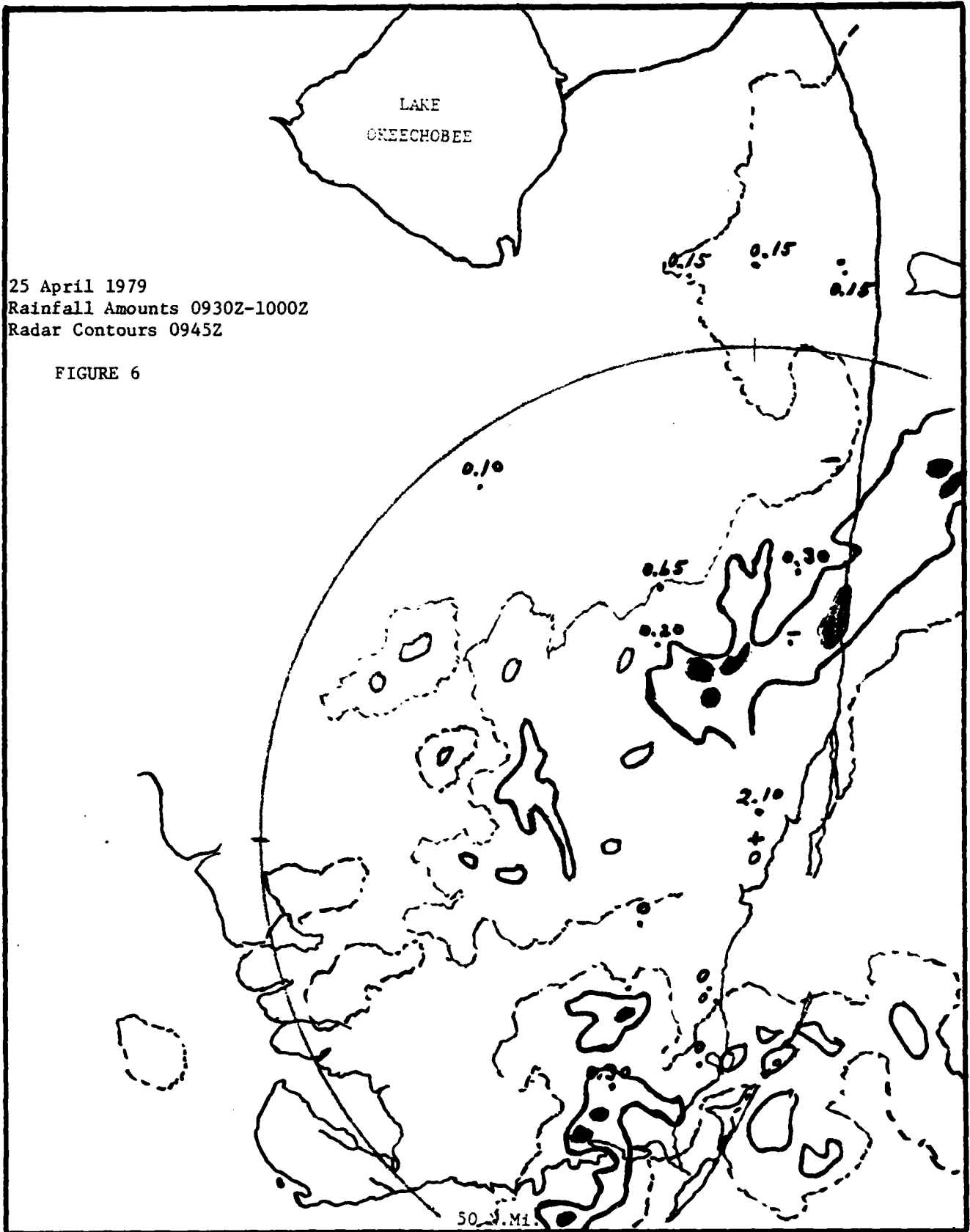

Fig. 4 - WSR-57 Radar at National Hurricane Center on Univ. of Miami Campus,  
1328Z, 25 April 79



25 April 1979  
Rainfall Amounts 0930Z-1000Z  
Radar Contours 0945Z

FIGURE 6



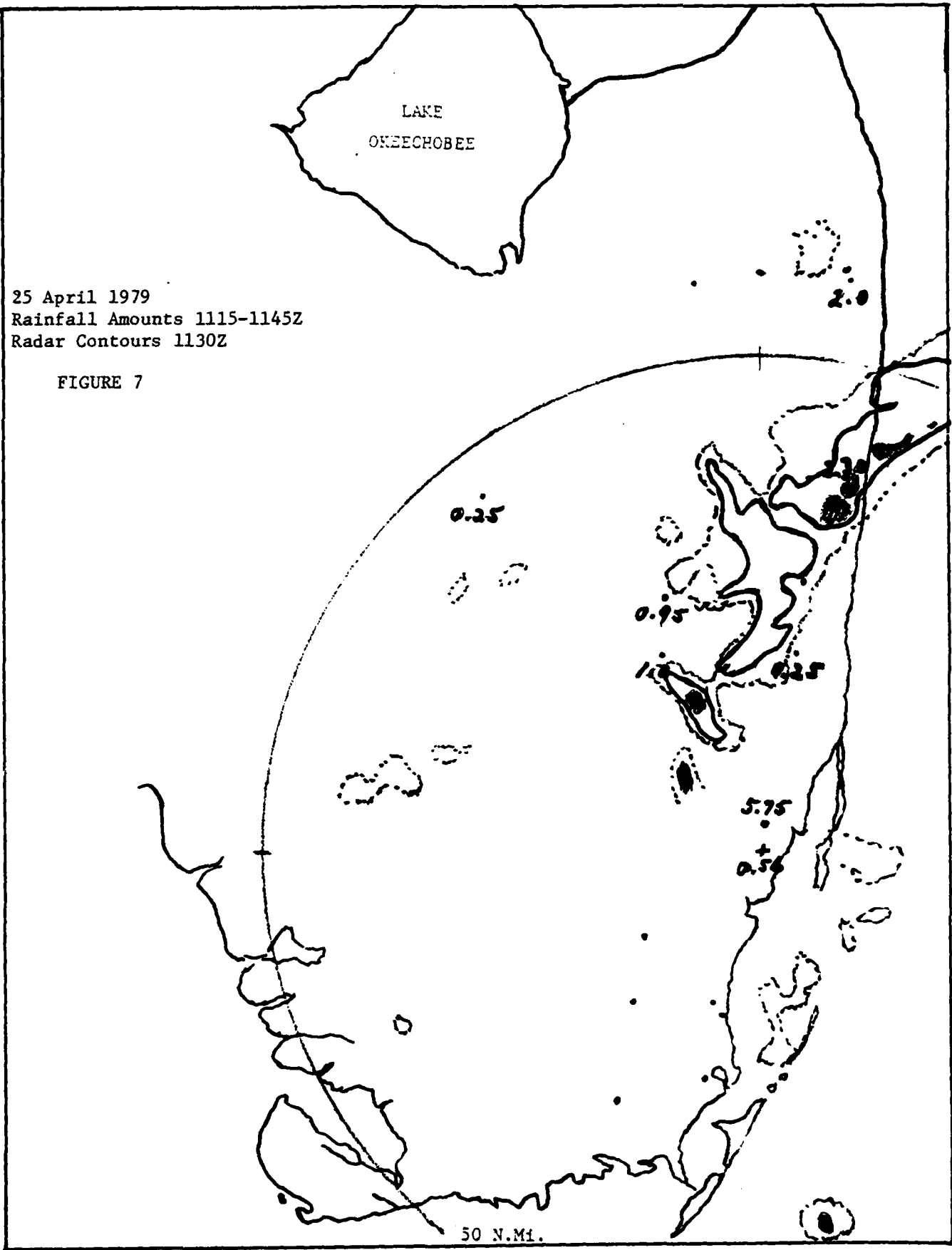

Bibliography On  
Precipitation Attenuation of Microwaves

1. Herzegh, P.H. and P.V. Hobbs, 1980: Observations of Snow Size Spectra in Frontal Clouds: Deviations from the Marshall-Palmer Form, Paper to be presented at the 8th International Conf. on Cloud Physics, July 15-19, Clermont-Ferrand, France, 4 pp.
2. Bloch, S.C., D. Davidson and D.D. Tang, 1978: Rain-Attenuation Experience with the Tampa Triad Using 19-GHz Comstar Satellite Beacon Signals, Proc. Eascon '78, IEEE 78CH 1354-4 AES, September, 379-384.
3. MacKenzie, E.C. and J.E. Allnutt, 1977: Effect of Squall-Line Direction on Space-Diversity Improvement Obtainable with Millimetre-Wave Satellite Radio-communication Systems, Reprint from Electronics Letters, Vol. 13 No. 19, September, 571-573.
4. Tang, D.D., D. Davidson and S.C. Bloch, 1980: Tampa Triad 19-GHz Rainy Season Diversity Results and Implications for Satellite Communication System Design, Pre-print of paper to be presented at the International Conf. on Communications, Seattle, Wash., June, 5 pp.
5. Rogers, R.R., M.K. Yau and O. Massambani, 1980: Further Studies of Rain Effects on Earth-Space Propagation, Stormy Weather Group Scientific Report MW-93, McGill University, December, 40 pp.
6. Hodge, D.B., 1976: Radar Studies of Rain Attenuation and Diversity Gain, Stormy Weather Group Scientific Report MW-87, McGill University, Canada, June, 42 pp.
7. Hogg, D.C. and T. Chu, 1975: The Role of Rain in Satellite Communications, IEEE, V. 63, No. 9, Sept., 1308-1331.
8. Merceret, F.J., 1974: On the Size Distribution of Raindrops in Hurricane Ginger, Mon. Wea. Rev., V. 102, 10, Oct., 714-716.
9. Gibbins, C.J., A.C. Gordon-Smith and D.L. Croom, 1975: Atmospheric Emission Measurements at 85 to 118 GHz, Planet Space Sci., V. 23, 61-73.
10. Ruthroff, C.L., 1969: Microwave Attenuation and Rain Gauge Measurements, IEEE, V. 57, 6, June, 1235-1236.
11. Medhurst, R.G., 1965: Rainfall Attenuation of Centimeter Waves: Comparison of Theory and Measurement, IEEE, Vol. AP-13, 4, July, 550-564.
12. Semplak, R.A., 1971: A Rare Event of Intense Rainfall, Mon. Wea. Rev., V. 99, 2, Feb., 155-157.
13. Hershfield, D.M., 1972: Estimating the Extreme-Value 1-Minute Rainfall, J. Appl. Meteor., V. 11, Sept., 936-940.

14. Reber, E.E. and D.V. McDonald, 1972: On the Reduction of Rainfall Outages by Space Diversity for Millimeter-Wave Earth-Satellite Communications Systems, J. Appl. Meteor., V. 11, Dec., 1374-1379.
15. Kinnell, P.I.A., 1972: The Acoustic Measurement of Water-Drop Impacts, J. Appl. Meteor., V. 11, June, 691-694.
16. Merceret, F.J., 1973: A Contribution to the Measurement of Raindrop Spectra with Airborne Foil Impactors, J. Appl. Meteor., V. 12, 5, August, 893-895.
17. Morrison, J.A. and T.S. Chu, 1973: Perturbation Calculations of Rain-Induced Differential Attenuation and Differential Phase Shift at Microwave Frequencies, The Bell System Tech. Journal, V. 52, 10, Dec., 1907-1913.
18. Bodtmann, W.F. and C.L. Ruthroff, 1974: Rain Attenuation on Short Radio Paths: Theory, Experiment and Design, The Bell System Tech. Journal, V. 53, 7, Sept. 1329-1349.
19. Mink, J.W. and E.P. Forrest, 1974: A Sensitive Tipping-Bucket Rain Gauge, Rev. Sci. Instrum., V. 45, 10, Oct., 1268-1270.
20. Huff, F.A., 1974: Statistics of Precipitation, Reprint Series No. 256, Illinois State Water Survey, Urbana, Ill., 74-88.
21. Freeny, A.E. and J.D. Gabbe, 1969: A Statistical Description of Intense Rainfall, The Bell System Tech. Journal, July-August, 1790-1851.
22. Briggs, J., 1968: Estimating the Duration of High-Intensity Rainfall, Meteorological Magazine, V. 97, 1155, Oct., 289-293.
23. Briggs, J. and J.A. Harker, 1969: Estimates of the Duration of Short-Period Rainfall Rates Based on Clock-Hour Values, Meteorological Magazine, 98, 246-252.
24. Semplak, R.A., 1966: Gauge for Continuously Measuring Rate of Rainfall, Rev. of Scientific Instruments, V. 37, 11, Nov., 1554-1558.
25. Bussey, H.E., 1950: Microwave Attenuation Statistics Estimated from Rainfall and Water Vapor Statistics, Proc. I.R.E., 781-785.
26. Wexler, R. and D. Atlas, 1963: Radar Reflectivity and Attenuation of Rain, J. Appl. Meteor., V. 2, Apr., 276-280.
27. Setzer, D.E., 1970: Computed Transmission Through Rain at Microwave and Visible Frequencies, The Bell System Tech. Journal, V. 49, 8, Oct., 1873-1892.
28. Ruthroff, C.L., 1970: Rain Attenuation and Radio Path Design, The Bell System Tech. Journal, V. 49, 1, Jan., 121-135.
29. Ruthroff, C.L., T.L. Osborne and W.F. Bodtmann, 1969: Short Hop Radio System Experiment, The Bell System Tech. Journal, V. 48, 6, July-August, 1577-1604.

30. Hogg, D.C., 1967: Path Diversity in Propagation of Millimeter Waves Through Rain, IEEE, V. AP-15, 3, May, 410-415.
31. Blevis, B.C., R.M. Dohoo and K.S. McCormick, 1967: Measurements of Rainfall Attenuation at 8 and 15 GHz, IEEE, V. AP-15, 3, May, 394-403.
32. Rogers, R.R., 1976: Statistical Rainstorm Models: Their Theoretical and Physical Foundations, IEEE, July, 547-566.
33. Hogg, D.C., 1968: Millimeter-Wave Communication through the Atmosphere, Science, Jan., 39-46.
34. Ruthroff, C.L. and W.F. Bodtmann, 1975: Computing Derivatives from Equally-Spaced Data, paper of Bell Telephone Laboratories, Inc., Crawford Hill Laboratory, Holmdel, N.J., 17 pp.
35. Semplak, R.A. and H.E. Keller, 1969: A Dense Network for Rapid Measurement of Rainfall Rate, The Bell System Technical Journal, July-August, 1745-1756.
36. Shimabukuro, F.I. and E.E. Epstein, 1970: Attenuation and Emission of the Atmosphere at 3.3 mm, IEEE, July, 485-490.
37. Semplak, R.A., 1970: The Influence of Heavy Rainfall on Attenuation at 18.5 and 30.9 GHz, IEEE, V. AP-18, 4, July, 507-511.
38. Harden, B.N., D.T. Llewellyn-Jones and A.M. Zavody, 1975: Investigations of Attenuation by Rainfall at 110 GHz in South-east England, IEE, V. 122, 6, June, 680-684.
39. Harden, B.N., J.R. Norbury and W.J.K. White, 1974: Model of Intense Convective Rain Cells for Estimating Attenuation on Terrestrial Millimetric Radio Links, Electron. Lett., 10, 483-484.
40. Davies, P.G., 1975: Attenuation by Cloud and Rain on Earth Sun Paths at 12 to 71 GHz, Electron. Lett., V. 11, 22, October.
41. Davis, A.R., 1976: Stochastic Models for Deriving Instantaneous Precipitation Rate Distributions, AWS-TR-76-263, Air Weather Service, U.S. Air Force, July, 20 pp.
42. Richard, V.W. and J.E. Kammerer, 1975: Rain Backscatter Measurements and Theory at Millimeter Wavelengths, BRL Report No. 1838, USA Ballistic Research Lab., Aberdeen Proving Ground, MD, Oct., 190 pp.
43. Winner, D.C., 1968: Climatological Estimates of Clock-Hour Rainfall Rates, Tech. Report 202, Air Weather Service (MAC) U.S. Air Force, June, 26 pp.
44. Sissenwine, N., 1972: Extremes of Hydrometeors at Altitude for MIL-STD-210B, AFCRL-72-0369, Air Force Cambridge Research Lab., Bedford, Mass., June, 20 pp.
45. Currie, N.C., F.B. Dyer and R.D. Hayes, 1975: Analysis of Radar Rain Return at Frequencies of 9.375, 35, 70, and 95 GHz, Tech. Report No. 2, Georgia Inst. of Technology, EES/GIT Project A-1485, Atlanta, Ga., Feb., 93 pp.

46. Mendenhall, L.D. and R.G. Feddes, 1977: A Simulation Model for Estimating Microwave Attenuation through Clouds and Rain, Proc. 7th Tech. Exch. Conf., Atmos. Sciences Lab., White Sands Missile Range, NM, 88002, April, 197-202.
47. Katz, I., A. Arnold, J. Goldhirsh, T.G. Konrad, W.L. Vann, E.B. Dobson and J.R. Rowland, 1975: Radar Derived Spatial Statistics of Summer Rain, Experiment Description, NASA CR-2592, V. I of III, Johns Hopkins University, Laurel, Maryland, Sept., 87 pp.
48. Konrad, T.G. and R.A. Kropfli, 1975: Radar Derived Spatial Statistics of Summer Rain, NASA CR-2592, Vol. II of III, Johns Hopkins University, Laurel, Maryland, Sept., 171 pp.
49. Applied Physics Laboratory, John Hopkins University, Laurel, Md., 1975: Radar Derived Spatial Statistics of Summer Rain, Appendices, NASA CR-2592, Vol. III of III, Sept., 116 pp.
50. Centre National D'Etudes des Telecommunications, Nice, France, 1973: The Fine Scale Structure of Precipitation and EM Propagation, Preprints of papers presented at I.U.C.R.M. Colloquim, 23-31 October, Tome 1 of 2, 195 pp.
51. Centre National D'Etudes des Telecommunications, Nice, France, 1973: The Fine Scale Structure of Precipitation and EM Propagation, Preprints of papers presented at I.U.C.R.M. Colloquim, 23-31 October, Tome 2 of 2, 175 pp.
52. Cottrell, K.G., P.D. Try, D.B. Hodges and R.F. Wachtmann, 1979: Electro-Optical Handbook, Volume 1, Weather Support for Precision Guided Munitions, AWS/TR-79/002, Air Weather Service (MAC) Scott AFB, Illinois, May, 97 pp.
53. Gerhardt, J.R., C.W. Tolbert, S.A. Brunstein and W.W. Bahn, 1961: Experimental Determinations of the Back-Scattering Cross-Sections of Water Drops and of Wet and Dry Ice Spheres at 3.2 Centimeters, J. Meteor., V. 18, 3, June, 340-347.
54. Stephens, J.J., 1961: Radar Cross-Sections for Water and Ice Spheres, J. Meteor., V. 18, 3, June, 348-359.
55. Clardy, D.E. and C.W. Tolbert, 1961: Electronic Disdrometer, Rev. Sci. Instrum., V. 32, 8, August, 916-919.
56. Boudreau, C.A. and M.L. Stone, 1965: Scattering and Attenuation by Precipitation Particles, ESD-TDR-65-598, Lincoln Laboratory, MIT, Lexington, Mass., August, 63 pp.
57. Hardy, K.R., 1962: A Study of Raindrop-size Distributions and their Variation with Height, AFCRL-62-1091, Dept. of Engineering Mechanics Meteorological Laboratories, University of Michigan, Ann Arbor, Mich., December, 174 pp.
58. Chu, T.S. and D.C. Hogg, 1968: Effects of Precipitation on Propagation at 0.63, 3.5, and 10.6 Microns, The Bell System Tech. J., V. 47, 5, May-June, pp 723-759.

59. Hathaway, S.D. and H.W. Evans, 1959: Radio Attenuation at 11 kmc and Some Implications Affecting Relay System Engineering, The Bell System Tech. J., Vol XXXVIII, 1, January, pp 73-97.
60. Hogg, D.C. and R.A. Semplak, 1961: The Effect of Rain and Water Vapor on Sky Noise at Centimeter Wavelengths, The Bell System Tech. J., Vol. XL, 5, Sept., pp 1331-1348.
61. Ruthroff, C.L. and R.R. Seibel, 1970: A Cylindrical Capacitor for Use in a Rain Gauge, Memorandum for Record, Bell Telephone Laboratories, Inc., N.Y. Feb., 11 pp.
62. Hitschfeld, W. and J.S. Marshall, 1954: Effect of Attenuation on the Choice of Wavelength for Weather Detection by Radar, Proc. I.R.E., Vol. 42, 7, July, 1166-1168.
63. Robertson, S.D. and A.P. King, 1946: The Effect of Rain upon the Propagation of Waves in the 1- and 3-Centimeter Regions, Proc. I.R.E., Vol. 34, April, 178-180.
64. Dingle, A.N., 1960: The Microstructure of Rain in a Summer Shower, Proc. 8th Weather Radar Conf., Am. Meteor. Soc., Boston, April 99-106.
65. Mueller, G.E., 1946: Propagation of 6-Millimeter Waves, Proc. I.R.E. and Waves and Electrons, Vol. 34, April, 181-183.
66. Hardy, K.R. and A.N. Dingle, 1960: Raindrop-Size Distributions in a Cold Frontal Shower, Proc. 8th Weather Radar Conf., Am. Meteor. Soc., Boston, April, 179-186.
67. Joss, J. and A. Waldvogel, 1969: A Distrometer for Raindrops, Marc Weibel dipl. Ing. ETH., Kapellenstrasse 20, 4000 Basel, Switzerland, 7 pp.
68. Shupiatskii, A.B., 1959: Radar Scattering by Non-Spherical Particles, Tsentral'naia Aerologicheskaja Observatoriia, Trudy, No. 30: 39-52, (Translated by Amer. Meteor. Soc., Boston), 23 pp.
69. Beard, C.I. and V. Twersky, 1960: Off-Forward Scattering from Random Volume Distributions of Spheres, EDL-E47, Electronic Defense Laboratories, P.O. Box 205, Mountain View, California, July, 57 pp.
70. Latour, M.H., 1951: Scattering and Attenuation of Microwave Signals by Hydrometeors, Monthly Progress Report No. 14, Oct. 1, 1951 to Nov. 1, 1951, AF 33(038)-14944, Engineering and Industrial Experiment Station, Dept. of Electrical Engineering, University of Florida, Nov., 7 pp.
71. Diem, M., 1961: The Size of Raindroplets, Final Technical Report June 1, 1960- May 31, 1961, Meteorologisches Institut, Technische Hochschule, Karlsruhe, Germany, October, 14 pp.
72. Nathan, A.M., 1968: Ground Based Raindrop Spectrometer II, Research and Development Technical Report ECOM-00157-F, ECOM, US Army Electronics Command, Fort Monmouth, N.J., March, 30 pp.

73. Mathur, P.N. and E.A. Mueller, 1955: Radar Back-Scattering from Non-Spherical Scatterers (Part 1- Cross-Sections of Conducting Prolates and Spheroidal Functions, Part 11- Cross-Sections from Non-Spherical Raindrops), Report of Investigation No. 28, State Water Survey Div., Urbana, Ill., 85 pp.
74. Frederick, R.H., V.A. Myers and E.P. Auciello, 1977: Five- to 60-Minute Precipitation Frequency for the Eastern and Central United States, NOAA Tech. Memo NWS HYDRO-35, Office of Hydrology, Silver Spring, Md., June, 36 pp.
75. U.S. Dept. of Commerce, Weather Bureau, 1955: Rainfall Intensity-Duration-Frequency Curves, Tech. Paper No. 25, Washington, D.C., December, 53 pp.
76. South Florida Water Management District, W. Palm Beach, Fla., 1979: Preliminary Report on the Severe Storm of April 24-25, 1979, 37 pp.
77. Bradley, J.H.S., 1970: Rainfall Extreme Value Statistics Applied to Microwave Attenuation Climatology, Stormy Weather Group Sc. Rpt. MW-66, McGill University, Montreal, February, 42 pp.
78. Cole, A.E. and N. Sissenwine, 1965: Surface Rates of Precipitation, Handbook of Geophysics and Space Environments, Chapter 5, McGraw-Hill Book Company.
79. Ippolito, L.J., 1981: Radio-Wave Propagation for Space Communications Systems, NASA Technical Paper 1770, NASA Office of Space and Terrestrial Applications, Wash., D.C., February, 58 pp.
80. Hitschfeld, W. and J.S. Marshall, 1954: Effect of Attenuation on the Choice of Wavelength for Weather Detection by Radar, Reprint from Proc. of the I.R.E., V. 42, 7, July, 1165-1168.
81. Atlas, D. and C.W. Ulbrich, 1974: The Physical Basis for Attenuation-Rainfall Relationships and the Measurement of Rainfall Parameters by Combined Attenuation and Radar Methods, Reprint J. De Recherches Atmospheriques, Paris, France, pp. 275-298.

## APPENDIX I

NUMBER OF HOURS OF OCCURRENCE OF  
LARGE RAINFALL RATES DURING YEARS  
1960 - 1978 INCLUSIVE

FLORIDA STATION	2.00"- 2.49"	2.50"- 2.99"	Over 3.00"	TOTAL
Apalachicola WSO AP	6	-	2	8
Belle Glade HRCN Gate	5	4	1	10
Blackman (Opened 7/75)	4	3	-	7
Blackman 3 WNW	1	-	-	1
Blackman 1 SE	2	-	-	2
Blackman 4 WNW	2	1	-	3
Boca Raton	4	4	1	9
Bristol	1	2	-	3
Brooksville 7 SSW	9	-	-	9
Brooksville Chin Hill	1	-	1	2
Canal Point Gate 5	3	3	1	7
Clewiston US Eng	5	3	-	8
Cross City 2 WNW	3	1	2	6
Cross City	-	-	-	-
Daytona Beach WSO AP	8	1	-	9
Dowling Park 1W	2	1	-	3
Dowling Park 3 NW	-	-	-	-
Dowling Park	-	-	-	-
Fort Myers WSO AP	14	7	3	24
Gainesville 3 WSW	4	1	-	5
Gainesville 2 WSW	3	2	1	6
Graceville	6	2	1	9
Grady	2	2	-	4
Homestead Exp. Sta.	12	1	3	16
Inglis 5 SSW (Opened 9/74)	1	-	1	2
Inglis	4	-	-	4
Jacksonville WSO AP; WB AP	7	6	2	15
Key West WSO AP	7	1	1	9
Lakeland 3 SE (Opened 9/78)	-	-	-	-
Lakeland WSO City (Closed 9/78)	9	2	1	12
Lisbon	8	-	-	8
Lynne	1	1	1	3
Lynne 4 SE	1	1	1	3

FLORIDA STATION	2.00"- 2.49"	2.50"- 2.99"	Over 3.00"	TOTAL
Marineland	2	-	-	2
Melbourne	7	1	2	10
Miami WSMO AP; WSO AP	12	4	2	18
Miami WSO City; WB City	9	3	-	12
Monticello 3W (Opened 9/71)	5	-	-	5
Moore Haven Lock 1	8	1	2	11
Niceville	7	1	1	9
North New RVR Canal 2	10	5	-	15
Orange City Tower	10	2	4	16
Orlando WSO McCoy (Opened 5/74)	1	2	-	3
Orlando WSO AP; Orlando WB AP (Closed 2/74)	9	1	2	12
Ortona Lock 2	8	2	-	10
Panacea 4 SSE	14	-	2	16
Panama City 5 NE (Opened 12/71)	4	1	-	5
Panama City 2	1	1	1	3
Parrish	3	3	3	9
Pennsuco 5 WNW; 5 NW; 4 NW	8	3	-	11
Port Mayaca SL Canal	10	2	2	14
Raiford State Prison	3	2	1	6
St. Leo	9	1	1	11
St. Lucie New Lock 1	7	5	5	17
St. Petersburg	1	1	1	3
Tallahassee WSO AP	10	2	3	15
Tamiami Trail 40 MI Bend	6	3	1	10
Tampa WSMO AP	3	-	-	3
Trail-Glade Ranges (Opened 12-66)	4	-	1	5
Venice	4	1	-	5
Venus 3 SE	14	3	-	17
Vero Beach 4W	6	1	-	7
Wausau 2 SSW (Opened 8-65)	9	-	1	10
West Palm Beach WSO AP	6	1	4	11
Woodruff Dam	5	-	-	5

METHODS FOR PERFORMANCE MONITORING AND RADAR CALIBRATION  
FOR DIGITAL SYSTEMS\*

R.V. Revert, H.V. Senn and H.W. Hiser  
Remote Sensing Lab., University of Miami  
Miami, Florida

## 1. INTRODUCTION

Some meteorological radar receivers are calibrated each day (Smith, 1968), some once each week, some as seldom as only at the beginning and end of a scientific data collection project. Experiments have failed partly because of radar calibration problems (Wilson and Brandes, 1979). Since radar systems are rarely so stable that one can be confident no significant changes took place when important and irreplaceable data were gathered, frequent system calibrations become absolutely necessary. Unfortunately, manual calibration requires two technicians, is time consuming, and requires that the radar be taken down from its surveillance role during the work.

At the Remote Sensing Laboratory (RSL) we have worked for some years to overcome those problems by providing semi-automatic calibration systems which are triggered during routine data collection. Information on the receiver's handling of signal levels is then processed and analysed concurrently with the data.

Other parts of the radar system normally change little from hour to hour or day to day. For instance, well maintained antenna and waveguide systems may need calibration only on a yearly basis; and changes in  $P_t$  are likely to be only a fraction of one db; while the receiver system may vary almost an order of magnitude more than the transmitter during a relatively short period of time. Therefore, in this paper we describe the current and future receiver calibration systems which have become necessary as a result of the increased demands on accuracy placed on the data because of the digitally processing of the data.

Initial calibration and later monitoring of receiver system parameters required the design and construction of a Range Bin Contents indicator (Rabicon). The Rabicon is a unit which displays a three-digit decimal number representative of the eight-bit binary number present in any one of two hundred selectable range bins.

The RF output of the microwave signal source is applied to a directional coupler in the waveguide and then detected and amplified by the radar receiver system. This video signal is then digitized and processed by the digital filter. To initially calibrate the values of RF output amplitude, the Rabicon is used to compare the numerical representation of output amplitude of

the microwave signal source to a known reference signal from a calibrated microwave signal generator. The output of the microwave signal source is then adjusted to match that of the reference.

The functions of the Rabicon could be achieved by other methods. But they were so time consuming that the experimental test data were normally put on tape, run through a computer, then examined and the system reset as necessary to produce the desired results. Since the Rabicon allows monitoring of test signals in real time without all of those complex steps, it is the heart of our calibration system. It is also extremely useful in setting the digital limits of data representing the dynamic range of the receiver and other functions described below.

## 2. SEMI-AUTOMATIC, RSL RECEIVER CALIBRATION SYSTEMS

A previous device (Andrews and Senn, 1968), was designed and constructed for calibration of radar data on film. This device was suitable for that medium; but for the much faster signal handling of data recording on digital tape and the demand of having the amplitude of the calibration pulses change every two-degree sector, a redesign of the RF stepped attenuator driver was required.

In the newer calibration system the known output of the microwave signal source is applied to a digitally programmable attenuator which varies attenuation in discrete steps of two decibels for every two-degree change of antenna rotation. This also causes the data to be recorded on magnetic tape. The dynamic range of the attenuator gives a total of forty decibels of RF output variation. These output step changes are monitored in real time by the Rabicon to observe the RF power input versus indicated digital number.

The system in use over the summer of 1979 is broken down into a block diagram in Fig. 1. The entire system is synchronized by the trigger and timing generator block which drives both the digital integrator (Sirmans and Doviak, 1973), and the calibration control circuitry. The digital integrator presently in use has a total storage of 200 range bins of selectable width of 1/4, 1/2 or 1 nm. The time constant of the recursive digital filter within the integrator has selectable values of 7, 15, 31, or 63 pulses. The data stored within each of the 200 range bins is an eight-bit byte which is recorded on a nine-track digital tape recorder during the transition of a two-degree output from a synchro-to-digital converter connected to the antenna azimuth synchro. In mode I, the antenna is scanning upward in dis-

\*Research supported by Navy ONR Contract N00014-75-C-0172 and Army ARO Grant DAAG29-77-G-0227.

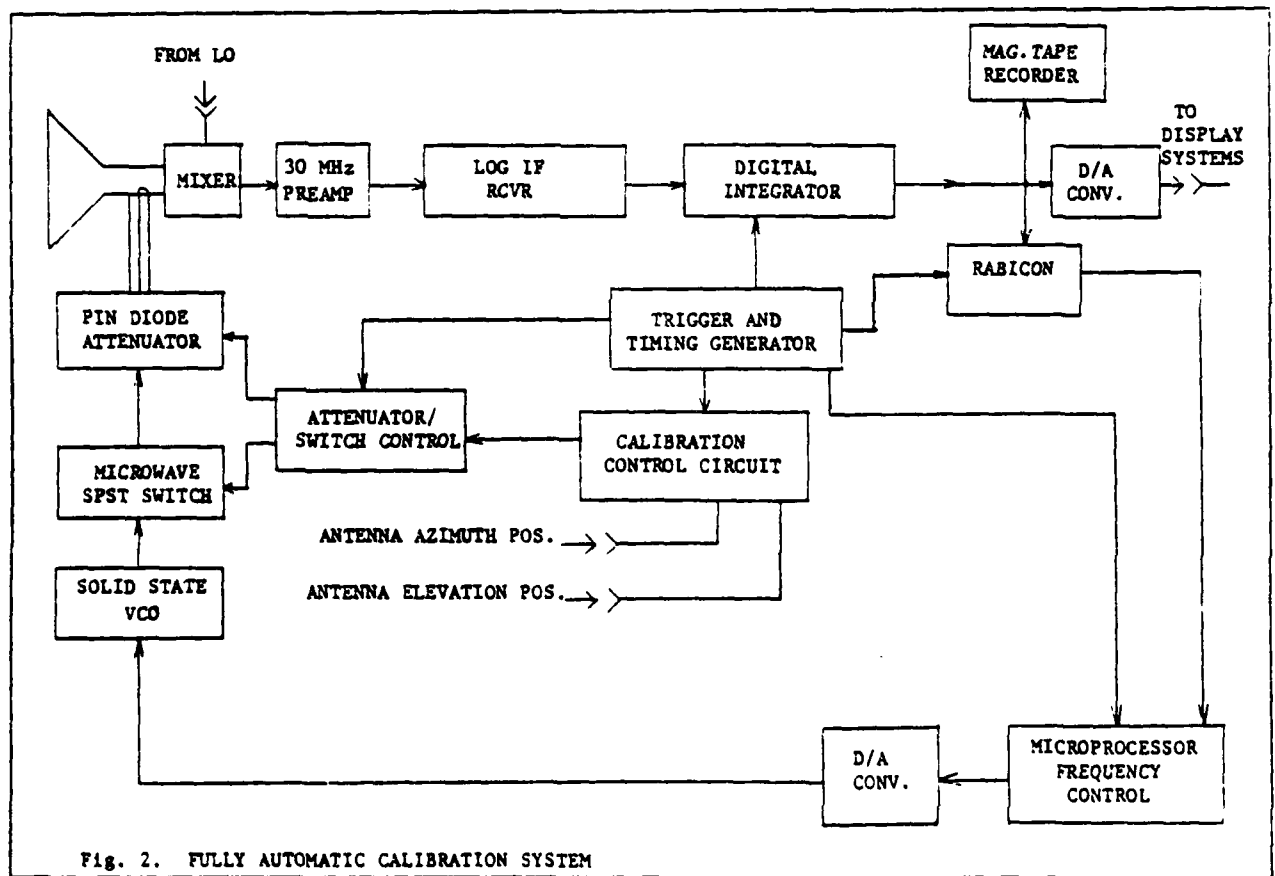
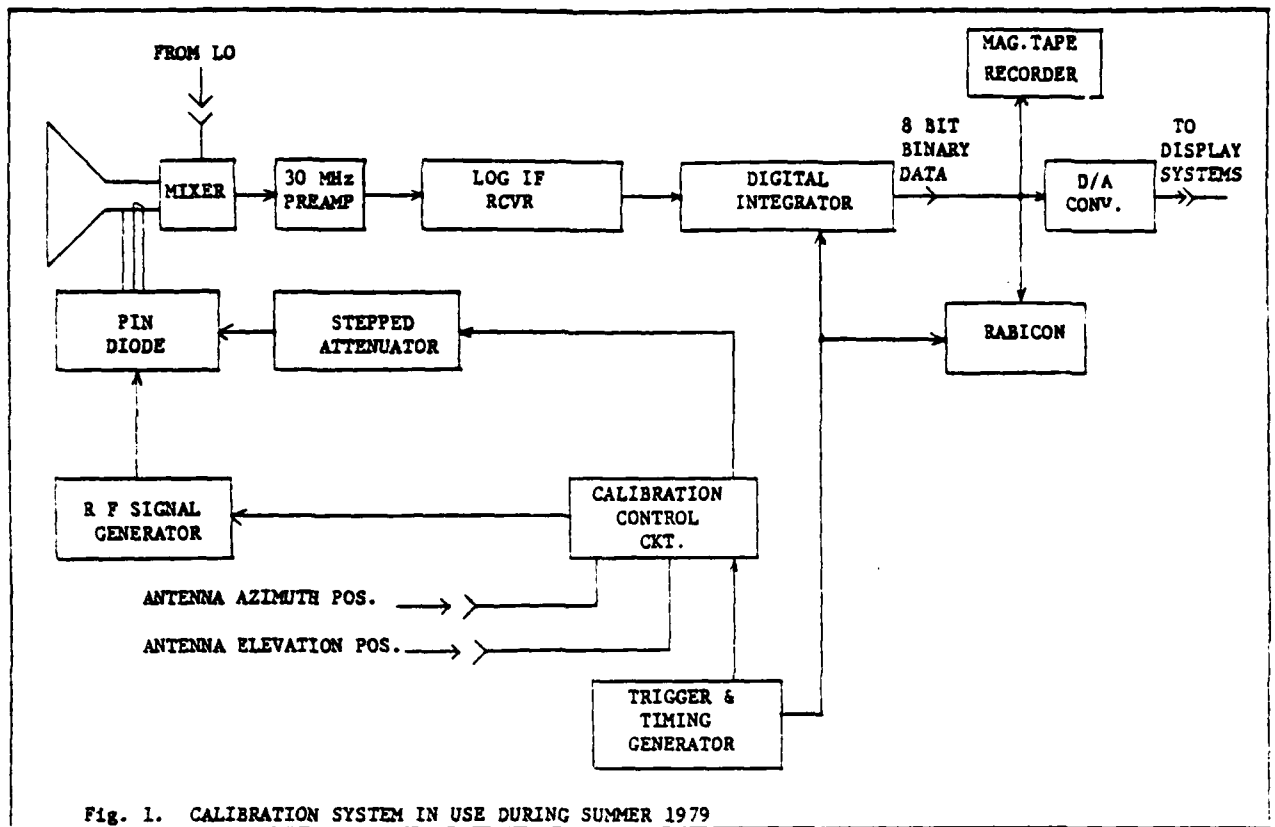

crete steps of elevation angle of approximately one degree, for CAPPI operation. In mode II, the antenna is driven down continuously (while rotating horizontally) to begin another CAPPI sequence at the bottom tilt angle.

The calibration control circuit operates synchronously with the digital integrator and changes its mode of operation as required by command signals generated at different antenna azimuth and elevation positions. In mode I of operation the RF signal generator is triggered "on" during range bin 196 and "off" at range bin 199 to fill the last four range bins with a test signal of sufficient width to simulate a weather echo return. The amplitude level of this test pulse at the outer extreme of range provides a constant check on receiver system status. In mode I of operation, the stepped attenuator driver is left in step one which is initially adjusted for no attenuation through the PIN diode; and essentially the direct output of the RF signal generator setting, which is typically -60 dbm, is fed into the directional coupler. When mode II of operation is selected, the RF signal generator is triggered repeatedly ten times on each sweep so that incoming echoes which might tend to contaminate some of the test pulses will not contaminate all of the test pulses.

After construction of the stepped attenuator driver, calibration of the driver to some known reference was required. A first attempt to calibrate the driver was the comparison of a reference pulse to the test pulse that was to be calibrated, on different channels of an oscilloscope. This method proved to be difficult and yielded many inaccuracies. Another technique needed to be developed and this led to the design and construction of the already defined Rabicon.

With the Rabicon we can select any of the two hundred range bins within the digital integrator storage section and display the contents in decimal representation in real time with a variable update rate. The variable update feature enables the operator to adjust the number of samples observed for optimum comprehension and observability from about once per second to five times per second. With the Rabicon we have the ability to switch from the range bin which contains the reference pulse from the signal generator to the range bin which contains the test pulse from the calibrator, reading the magnitude of the signal as a decimal number from 0 to 255 which is representative of the power level input. The problem of setting up the attenuator step levels is reduced to one of matching numerical values.

The subsequent use of the Rabicon led to many other applications and yielded a wealth of information as to the overall performance of the receiver/digital integrator system. For example, dialing in a range bin with no echo the Rabicon displayed the noise floor level of the integrator and the approximate variance of the noise. It was in this manner that the Rabicon assisted in the development of the Clear Air Eliminator (CAE). The purpose of the CAE was to prevent the writing of data on tape when the block of data did not contain signals above a certain threshold.

This minimized tape use immensely. By observing the peak of the noise with the Rabicon, the threshold of the CAE was set slightly above this level. Statistically, some noise pulses occurred above this threshold, but the false records were a minimal number.

The Rabicon was also used for adjusting the receiver/integrator system lower level to maximize the dynamic range of the system and monitor any dc drift of the system which would tend to raise or lower the floor.

The output of the Rabicon could also be applied to a digital-to-analog converter which is "enabled" only during calibration time. The analog output would drive a chart recorder y-axis while the calibration step number would drive the x-axis thereby giving the calibration curve in real time. The curve could be displayed on a microcomputer CRT terminal and the output could also be available to drive a printer for hard copy. This curve generating procedure has been done (Wiggert and Andrews, 1974) by a computer after the data were taken, when, unfortunately, nothing could be done to correct any inconsistencies already in the data.

Although the second semi-automatic calibration system was a great improvement over old methods, it was not a totally hands off system. It only approached the fully automatic system we sought. There was still one portion of the system which required manual control: relative frequency drifts occurring between the RF signal generator and the radar magnetron occasionally would change the magnitude of the test pulse. The Rabicon aided in evaluation of this relative frequency change since the test pulse at range bin 197 could be monitored for any amplitude change by a change in the numerical value of the display. After a change was noted, the signal generator could be "peaked" to attain the former value present on the display; but that required constant observation. To overcome the shortcomings of the semi-automatic system, a third generation calibration system was designed and is now under construction.

### 3. FULLY AUTOMATIC RSL RECEIVER CALIBRATION SYSTEM

The new design incorporates many additions to improve system performance and one major redesign for totally automatic calibrations. See Figure 2. In the first system the PIN diode limited the dynamic range of test signals applied to 40 db; but typically, weather echo returns may span a range of amplitude exceeding 50 db. For this reason another RF attenuator was selected. An absorptive PIN diode attenuator utilizing two PIN diodes meets the dynamic range and speed requirements of the new system. This attenuator also provides changes in RF attenuation in increments of 1 db allowing greater resolution of amplitude. It now increases the calibration sector to 120°, representing sixty, 2°, 1-db calibration steps instead of the twenty, 2°, 2-db steps of the old system.

The major redesign is shown in Figure 2 by the microprocessor frequency control, DA converter, voltage controlled oscillator (VCO), and

Microwave SPST switch boxes. The new system was designed to operate in the following manner: The test signal present under normal operation in range bins 196 through 199 is monitored by the microprocessor which controls a loop that will try to maximize the signal in range bin 197. The program in the microprocessor controls the frequency output of a VCO automatically "peaking" the RF output which previously required an operator. The output of the VCO is a CW signal which is applied to a high speed microwave switch to chop up the CW output in order to create the test pulses needed for calibration. The remainder of the system remains intact, except for minor modifications. The new system will achieve the goals of hands-off automatic calibration, a major step towards better quantitative analysis of the radar data.

#### 4. DISCUSSION AND CONCLUSIONS

The fully-automatic receiver calibration system that has evolved for an all digital radar system has many advantages over its predecessors. It provides for frequent calibrations without being labor intensive. Commercial signal generators can be purchased that can be programmed for stepped output to calibrate a receiver system over a wide dynamic range of signals. However, they cost far more than our system and do not include the feedback loop to automatically tune the generator to the frequency of the radar transmitter. Potemkin (1975) devised a system which inserted a reference signal matched to the transmitter frequency at the end of each pulse period. But he used only a constant amplitude signal near the center of the receiver dynamic range to monitor changes in system performance. The small size and compact nature of the new RSL calibrator will permit it to be installed as an integral part of most radar receiver systems.

One might question the method of controlling the frequency output of the VCO to lock it to the radar transmitter frequency. A conventional AFC loop could be used where the radar transmitter frequency is directly monitored as a means of tuning the VCO to match it. However, the method we have used should be equally good for this particular application. For a given output signal amplitude from the VCO, its frequency will be tuned to that of the transmitter when the maximum digital value is obtained in range bin 197 that is used for continuous display and monitoring of the test signal.

The Rabicon ties the whole system together by allowing the operator to digitally monitor the calibration signals, the performance of the CAE with respect to background noise, and the intensity of a storm as seen in any chosen range bin with the antenna rotating or stopped. Overall receiver and digital filter system performance are monitored by use of the Rabicon. The Rabicon is used to monitor the noise distribution at the low end of the dynamic range of the system. This lower level is adjusted to maximize the dynamic range, delete most unwanted noise upon demand and yet not exclude low-level signals from entering the system. Monitoring the numerical output of the Rabicon thus enables the operator to have a constant real time check of dynamic range and overall system performance. This unit

is physically located with the tape recording system and control panel for the radar digitizer.

The Rabicon, together with the automatic calibrator, make it possible to either manually or automatically plot a transfer curve relating receiver signal input to the radar digitizer output in real time. Thus, system malfunctions can be detected before and during data gathering rather than after data have been subject to computer processing (Silver and Geotis, 1976), or possibly lost forever.

#### REFERENCES

- Andrews, G. F., and H. V. Senn, 1968: Semi-automatic calibration of receiver and video system characteristics for weather radars. Proc. 13th Radar Meteor. Conf., Montreal, Amer. Meteor. Soc., 66-70.
- Potemkin, I. G., 1975: Calibration of weather radars. Proc. 16th Radar Meteor. Conf., Houston, Amer. Meteor. Soc., 40.
- Silver, W. M., and S. G. Geotis, 1976: On the handling of digital data. Proc. 17th Conf. Radar Meteor., Seattle, Amer. Meteor. Soc., 462-467.
- Sirmans, D., and R. J. Doviak, 1973: Meteorological radar signal intensity estimation. NOAA Tech. Memo., ERL NSSL-64, 80 pp.
- Smith, P. L., 1968: Calibration of weather radars. Proc. 13th Radar Meteor. Conf., Montreal, Amer. Meteor. Soc., 60-65.
- Wiggert, V., and G. F. Andrews, 1974: Digitizing, recording, and computer processing weather radar data at the experimental meteorology laboratory. NOAA Tech. Memo., ERL WMP-17, 70 pp.
- Wilson, J. W., and E. A. Brandes, 1970: Radar measurement of rainfall-- a summary. Bull. Amer. Meteor. Soc., 60, 1048-1058.