

LEVEL ~~X~~

2

NAVAL POSTGRADUATE SCHOOL
Monterey, California

AD A102372



DTIC
SELECTED
AUG 3 1981

THESIS

AN INTRODUCTION TO A RELIABILITY SHORTHAND

by

John J. Repicky, Jr.

March 1981

Thesis Advisor: James D. Esary

Approved for public release, distribution unlimited

DTIC FILE COPY

81 8 03 040

Unclassified

SECURITY CLASSIFICATION OF THIS PAGE/When Data Entered

Item 20, continued:

Simple examples show the convenience of this shorthand. The Ti-59 is demonstrated to be a useful tool, adequate to implement the methodology.

Accession For	
RTIS CR&I	<input checked="" type="checkbox"/>
RTIC TR	<input type="checkbox"/>
Unannounced	<input type="checkbox"/>
Justification	
By _____	
Distribution/	
Availability Codes	
Dist	Avail and/or
A	Special

Approved for public release, distribution unlimited

An Introduction to a Reliability Shorthand

by

John J. Repicky, Jr.
Lieutenant Commander, United States Navy
B.S., United States Naval Academy, 1971

Submitted in partial fulfillment of the
requirement for the degree of

MASTER OF SCIENCE IN OPERATIONS RESEARCH

from the

NAVAL POSTGRADUATE SCHOOL
March 1981

Author:

John J. Repicky, Jr.

Approved by:

James D. Esary

Thesis Advisor

[Signature]

Second Reader

[Signature]

Chairman, Department of Operations Research

Dean of Information and Policy Sciences

ABSTRACT

The determination of a system's life distribution usually requires the synthesis of a mixture of system survival modes. In order to alleviate the normal non-trivial calculations, this paper presents the concept of a reliability shorthand.

After describing the possible ways a system can survive a mission, the practitioner of this shorthand can use stock formulas to obtain a system's survival function. Then simple insertion of the failure rates of the system's components into the known equations results in the system's reliability.

Simple examples show the convenience of this shorthand. The Ti-59 is demonstrated to be a useful tool, adequate to implement the methodology.

TABLE OF CONTENTS

I.	INTRODUCTION -----	7
II.	RELIABILITY SHORTHAND -----	9
	A. A SYSTEM HAVING TWO ACTIVE COMPONENTS IN SERIES -----	9
	B. A STANDBY SYSTEM HAVING ONE ACTIVE AND ONE SPARE COMPONENT -----	10
	1. Identical Components -----	11
	2. Dissimilar Components -----	12
	C. A SYSTEM HAVING TWO ACTIVE COMPONENTS IN PARALLEL -----	13
	D. A STANDBY SYSTEM HAVING TWO ACTIVE COMPONENTS IN SERIES WITH ONE SPARE COMPONENT -----	15
III.	MIXING DISTRIBUTIONS -----	18
	A. MIX NOTATION -----	18
	1. A System having two Active Components in Parallel -----	18
	2. Distributive Property -----	20
	3. A Standby System Having one Active and a Possible Spare Component -----	21
	B. DEGENERACY AT ZERO -----	23
IV.	SUMMARY -----	26
	APPENDIX: A -----	27
	APPENDIX: B -----	36
	BIBLIOGRAPHY -----	43
	INITIAL DISTRIBUTION LIST -----	44

LIST OF FIGURES

1. Two active components in series-----	9
2. A single active component with one spare component-----	11
3. Two active components in parallel-----	13
4. Two active components in series with one spare component-----	15
5. Distributive Property of the MIX notation-----	20
6. A single active component possibly having one spare component-----	22
7. Survival function of the ZERO distribution-----	24
8. Distributive Property incorporating the ZERO distribution-----	25

I. INTRODUCTION

It is generally accepted that the reliability of a system is the probability that the system will operate adequately for a given period of time in its intended application. The determination of a system's life distribution usually requires the synthesis of a mixture of modes in which the system can survive. One can assuredly state that the calculations can be non-trivial.

This paper will present the concept of a reliability shorthand which can greatly simplify the degree of mathematical difficulty usually encountered in determining the reliability of a system. After describing the possible ways a system can survive a mission, the practitioner of this reliability shorthand methodology can specialize a standard formula to obtain a system's survival function. Then simple insertion of the failure rates of the system's components into known preformulated equations results in the system's reliability.

The convenience of this methodology is demonstrated through several simple examples. The reliability shorthand for many systems is catalogued in Appendix A as a ready reference. In Appendix B is a Ti-59 program which allows for the easy calculation of a system's reliability for two general cases of the shorthand methodology.

The concept of a reliability shorthand was first introduced in the Operations Research course 0A4662, 'Reliability and Weapons System Effectiveness Measurement'. The concept has evolved with each presentation of the course. It is hoped this paper will be a beneficial tutorial aid for the students of that course, and act as an introduction to the topic for the interested reader.

II. RELIABILITY SHORTHAND

As a convenient shorthand we will use the convention that the expression $\text{EXP}(\lambda_1) + \text{EXP}(\lambda_2)$ denotes the distribution for a random variable $T_1 + T_2$, where T_1, T_2 are independent, T_1 has an $\text{EXP}(\lambda_1)$ distribution, and T_2 has an $\text{EXP}(\lambda_2)$ distribution. The life distribution of many systems can be usefully described using this shorthand.

In the following examples we typically suppose that the components of the systems fail independently and have exponential life distributions.

A. A SYSTEM HAVING TWO ACTIVE COMPONENTS IN SERIES

A two component series system functions if, and only if, both active components, A_1 and A_2 , function. The life of the system, T , would be the minimum of the two component lives, $T = \min(T_1, T_2)$.



FIGURE 1: TWO ACTIVE COMPONENTS IN SERIES

We will assume $T_1 \sim \text{EXP}(\lambda_1)$, $T_2 \sim \text{EXP}(\lambda_2)$, and T_1, T_2 are independent. The system's survival function is

$$\begin{aligned}\bar{F}(t) &= P(T > t) \\ &= P(\min(T_1, T_2) > t) \\ &= P(T_1 > t, T_2 > t).\end{aligned}$$

Using the assumptions of independence and components having exponential life distributions we obtain

$$\begin{aligned}
 \bar{F}(t) &= P(T_1 > t) P(T_2 > t) \\
 &= \bar{F}_1(t) \bar{F}_2(t) \\
 &= e^{-\lambda_1 t} e^{-\lambda_2 t} \\
 &= e^{-(\lambda_1 + \lambda_2)t}.
 \end{aligned}$$

The life distribution of the system is $T \sim \text{EXP}(\lambda_1 + \lambda_2)$.

When $\lambda_1 = \lambda_2 = \lambda$, then $\bar{F}(t) = e^{-2\lambda t}$ and $T \sim \text{EXP}(2\lambda)$.

Our shorthand notation $\text{EXP}(2\lambda)$ represents the life distribution of a system where two identical components must both function for the system to survive.

B. A STANDBY SYSTEM HAVING ONE ACTIVE AND ONE SPARE COMPONENT

An active component, A, is to complete a mission of duration t . A spare component, S, is available to automatically replace the active component should it fail. The life of the active component is T_1 . The life of the spare component is T_2 . The life of the system is $T = T_1 + T_2$.

In determining the survival function of this system, we first describe how the system can survive to successfully complete a mission of duration t . Component A can live to time t with the spare never being utilized, or component A can fail at some intermediate time s . Then the spare component automatically replaces the failed component, and component S must live from time s to time t to successfully complete the mission.

With T_1, T_2 independent, the survival function of the system can be represented as:

$$\bar{F}(t) = \bar{F}_1(t) + \int_0^t \bar{F}_2(t-s) f_1(s) ds,$$

where $\bar{F}_1(t)$ is the probability of component A living to time t , $f_1(s)$ is the likelihood that component A fails at some time s , and $\bar{F}_2(t-s)$ is the probability that component S lives from time s to time t .

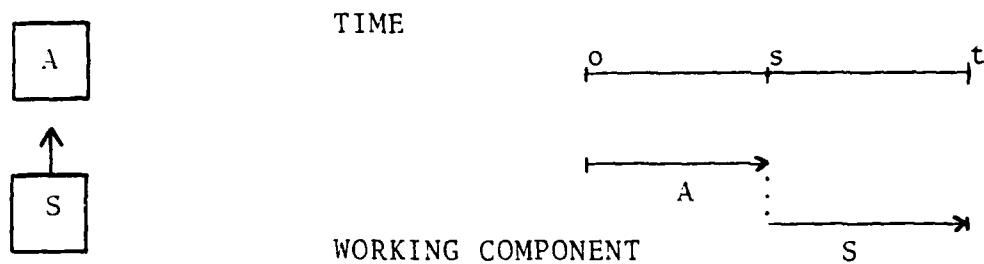

FIGURE 2: A SINGLE ACTIVE COMPONENT WITH ONE SPARE COMPONENT

1. Identical Components

If the active and spare components are identical, then $T_1 \sim \text{EXP}(\lambda)$, $T_2 \sim \text{EXP}(\lambda)$, T_1, T_2 are independent, and $T = T_1 + T_2$. The survival function is now expressed as

$$\begin{aligned} \bar{F}(t) &= e^{-\lambda t} + \int_0^t e^{-\lambda(t-s)} (\lambda e^{-\lambda s}) ds \\ &= e^{-\lambda t} + \int_0^t e^{-\lambda t} e^{\lambda s} \lambda e^{-\lambda s} ds \\ &= e^{-\lambda t} + e^{-\lambda t} \int_0^t \lambda ds \\ &= e^{-\lambda t} + e^{-\lambda t} (\lambda t) \\ &= (1 + \lambda t) e^{-\lambda t}. \end{aligned}$$

The shorthand notation for this survival function is $\text{EXP}(\lambda) + \text{EXP}(\lambda)$. Visualize this as a system having one $\text{EXP}(\lambda)$ component, and upon that component's failure the system

has a completely new and identical $\text{EXP}(\lambda)$ component because of the spare.

2. Dissimilar Components

If the active and spare components are dissimilar, then $T_1 \sim \text{EXP}(\lambda_1)$, $T_2 \sim \text{EXP}(\lambda_2)$, T_1 , T_2 are independent, and $T = T_1 + T_2$. The formulation of the survival function for this system is identical to the case of similar components, except for the change in failure rates. The survival function is

$$\begin{aligned}
 \bar{F}(t) &= e^{-\lambda_1 t} + \int_0^t e^{-\lambda_2(t-s)} \lambda_1 e^{-\lambda_1 s} ds \\
 &= e^{-\lambda_1 t} + \int_0^t e^{-\lambda_2 t} e^{\lambda_2 s} \lambda_1 e^{-\lambda_1 s} ds \\
 &= e^{-\lambda_1 t} + \lambda_1 e^{-\lambda_2 t} \int_0^t e^{-(\lambda_1 - \lambda_2)s} ds \\
 &= e^{-\lambda_1 t} + \lambda_1 e^{-\lambda_2 t} \left(\frac{1}{\lambda_1 - \lambda_2} \right) \int_0^t (\lambda_1 - \lambda_2) e^{-(\lambda_1 - \lambda_2)s} ds \\
 &= \frac{\lambda_1 - \lambda_2}{\lambda_1 - \lambda_2} e^{-\lambda_1 t} + \frac{\lambda_1}{\lambda_1 - \lambda_2} e^{-\lambda_2 t} (1 - e^{-(\lambda_1 - \lambda_2)t}) \\
 &= \frac{(\lambda_1 - \lambda_2) e^{-\lambda_1 t} + \lambda_1 e^{-\lambda_2 t} (1 - e^{-(\lambda_1 - \lambda_2)t})}{\lambda_1 - \lambda_2} \\
 &= \frac{\lambda_1 e^{-\lambda_1 t} - \lambda_2 e^{-\lambda_1 t} + \lambda_1 e^{-\lambda_2 t} - \lambda_1 e^{-\lambda_2 t} e^{-(\lambda_1 - \lambda_2)t}}{\lambda_1 - \lambda_2} \\
 &= \frac{\lambda_1 e^{-\lambda_2 t} - \lambda_2 e^{-\lambda_1 t}}{\lambda_1 - \lambda_2} .
 \end{aligned}$$

The shorthand notation for this survival function is $\text{EXP}(\lambda_1) + \text{EXP}(\lambda_2)$. As the active component fails a new component takes its place to complete the same task, however, the new component has a different failure rate than that of the initial component.

C. A SYSTEM HAVING TWO ACTIVE COMPONENTS IN PARALLEL

A two component parallel system functions if, and only if, at least one component functions. The life of the system, T , would be the maximum of the two component lives, $T = \max(T_1, T_2)$.

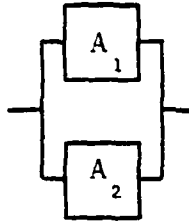

FIGURE 3: TWO ACTIVE COMPONENTS IN PARALLEL

Now assume $T_1 \sim \text{EXP}(\lambda_1)$, $T_2 \sim \text{EXP}(\lambda_2)$, and T_1, T_2 are independent. The survival function of the parallel system is

$$\begin{aligned}\bar{F}(t) &= P(\max(T_1, T_2) > t) \\ &= 1 - P(\max(T_1, T_2) \leq t) \\ &= 1 - P(T_1 \leq t, T_2 \leq t).\end{aligned}$$

Using the assumption of independence

$$\begin{aligned}\bar{F}(t) &= 1 - [P(T_1 \leq t) P(T_2 \leq t)] \\ &= 1 - [(1 - \bar{F}_1(t)) (1 - \bar{F}_2(t))] \\ &= 1 - [1 - \bar{F}_1(t) - \bar{F}_2(t) + \bar{F}_1(t)\bar{F}_2(t)] \\ &= \bar{F}_1(t) + \bar{F}_2(t) - \bar{F}_1(t)\bar{F}_2(t).\end{aligned}$$

Using the assumption that the components have exponential life distributions, the resulting life distribution is

$$\bar{F}(t) = e^{-\lambda_1 t} + e^{-\lambda_2 t} - e^{-(\lambda_1 + \lambda_2)t}.$$

When $\lambda_1 = \lambda_2 = \lambda$, the survival function is

$$\bar{F}(t) = e^{-\lambda t} + e^{-\lambda t} - e^{-(\lambda + \lambda)t} = 2e^{-\lambda t} - e^{-(\lambda_1 + \lambda_2)t}.$$

The life of the parallel system begins with both active components functioning together for system survival. The time until one of the components fails has the distribution $\text{EXP}(\lambda)$. When one of the components fails, the memoryless property of the exponential distribution provides that the surviving component has an additional $\text{EXP}(\lambda)$ life with which to complete the mission. The shorthand notation for the survival function of the simple parallel system of identical components is $\text{EXP}(2\lambda) + \text{EXP}(\lambda)$.

Now we will demonstrate the ease of using the reliability shorthand, compared to alternative calculations for determining a system's reliability. Recall that $\text{EXP}(\lambda_1) + \text{EXP}(\lambda_2)$ is the shorthand notation for the survival function

$$\bar{F}(t) = \frac{\lambda_1 e^{-\lambda_2 t} - \lambda_2 e^{-\lambda_1 t}}{\lambda_1 - \lambda_2}.$$

Noting that the parallel system is described by $\text{EXP}(2\lambda) + \text{EXP}(\lambda)$, we can see the simplicity of substituting 2λ for λ_1 and λ for λ_2 into the known survival function equation. The resulting survival function is

$$\begin{aligned} F(t) &= \frac{(2\lambda)e^{-(\lambda)t} - (\lambda)e^{-(2\lambda)t}}{(2\lambda) - (\lambda)} \\ &= \frac{\lambda(2e^{-\lambda t} - e^{-2\lambda t})}{\lambda} \\ &= 2e^{-\lambda t} - e^{-2\lambda t}. \end{aligned}$$

The survival functions are equivalent using either method, however, the shorthand methodology uses merely substitution and simple mathematics.

D. A STANDBY SYSTEM HAVING TWO ACTIVE COMPONENTS IN SERIES WITH ONE SPARE COMPONENT

Consider a system which has two identical components in series with a similar component as a standby spare which automatically replaces the first component that fails.

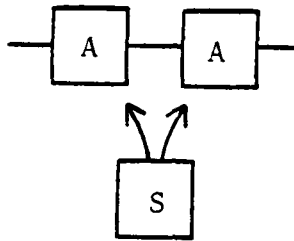

FIGURE 4: TWO ACTIVE COMPONENTS IN SERIES WITH ONE SPARE COMPONENT

The system has component times to failure $T_1 \sim \text{EXP}(\lambda)$, $T_2 \sim \text{EXP}(\lambda)$ and spare component time to failure $T_3 \sim \text{EXP}(\lambda)$, with T_1, T_2, T_3 independent. This system can complete its mission of duration t in two possible ways. It can survive if the original components live to time t and the spare component is never needed. Alternatively, one of the active components could fail at some intermediate time s , causing the system to fail. At that time the surviving component is like new and the spare component replaces the failed component creating a brand new series system to complete the mission from time s to time t .

In determining the system's survival function using reliability shorthand, we recall that a two component series system has an $\text{EXP}(2\lambda)$ life distribution. With the spare component replacement the system accomplishes the task as if it had two independent series systems to function consecutively. The shorthand notation is simply $\text{EXP}(2\lambda) + \text{EXP}(2\lambda)$.

Recall that the shorthand notation $\text{EXP}(\lambda) + \text{EXP}(\lambda)$ represents the life distribution where the survival function is $\bar{F}(t) = (1 + \lambda t)e^{-\lambda t}$. To determine the survival function of $\text{EXP}(2\lambda) + \text{EXP}(2\lambda)$ we substitute 2λ for λ into the known formula and obtain

$$\bar{F}(t) = (1 + 2\lambda t)e^{-2\lambda t}.$$

The usual method of determining the survival function is slightly more involved. The system can survive if the original series system lives to time t with no spare required. If one of the original components fails at some intermediate time s , then the spare component and the surviving component combine as a new series system. Both of the components of the new series system must live from time s to time t for the system to complete the mission. We formulate the survival function

$$\begin{aligned} \text{as } \bar{F}(t) &= e^{-2\lambda t} + \int_0^t e^{-\lambda(t-s)} e^{-\lambda(t-s)} 2\lambda e^{-2\lambda s} ds \\ &= e^{-2\lambda t} + \int_0^t e^{-\lambda t} e^{\lambda s} e^{-\lambda t} e^{\lambda s} 2\lambda e^{-2\lambda s} ds \\ &= e^{-2\lambda t} + e^{-2\lambda t} \int_0^t 2\lambda ds \\ &= e^{-2\lambda t} + e^{-2\lambda t} (2\lambda t) \\ &= (1 + 2\lambda t)e^{-2\lambda t}. \end{aligned}$$

The results are identical but the difference in mathematical difficulty is obvious. To easily determine a system's life distribution one need only be able to describe how the system successfully survives a mission, and then take advantage of the simple reliability shorthand methodology. In the next chapter we will expand this notation to include mixing of distributions.

III. MIXING DISTRIBUTIONS

In previous cases of systems utilizing spare components we assumed that those spare components would automatically and successfully replace failed components. Successful replacement occurred with probability equal to one. Perfect equipment in real life does not exist. We will assume that switchover and replacement by a spare component occurs with probability p , where $0 < p < 1$. No transfer occurs with probability $1-p$.

A. MIX NOTATION

For general application let D_1 and D_2 represent the probability distributions of the independent random times to failure T_1 and T_2 . Let $D_1 + D_2$ stand for the distribution of the sum $T_1 + T_2$. Now let the notation

$$\text{MIX}(p_1 D_1, p_2 D_2)$$

denote the mixture of the distributions D_1 and D_2 with respect to the mixing probabilities p_1 and p_2 , where $p_1 + p_2 = 1$.

This mixture of distributions has the survival function

$$\bar{F}(t) = p_1 \bar{F}_1(t) + p_2 \bar{F}_2(t),$$

where $\bar{F}_1(t)$ and $\bar{F}_2(t)$ are the survival functions for D_1 and D_2 .

1. A System having two Active Components in Parallel

A simple parallel system continues to survive as long as either active component still functions, regardless of the

order in which they fail. Assume component A_1 has life $T_1 \sim \text{EXP}(\lambda_1)$, component A_2 has life $T_2 \sim \text{EXP}(\lambda_2)$, T_1, T_2 are independent, and $T = \text{maximum}(T_1, T_2)$.

From what we know of parallel systems, the life distribution is $\text{EXP}(\lambda_1 + \lambda_2) + \text{EXP}(\lambda_1)$ if component A_2 is the first to fail, or it is $\text{EXP}(\lambda_1 + \lambda_2) + \text{EXP}(\lambda_2)$ if component A_1 fails first. The probability that A_1 fails before A_2 is $\frac{\lambda_1}{\lambda_1 + \lambda_2}$, and that A_2 fails before A_1 is $\frac{\lambda_2}{\lambda_1 + \lambda_2}$. The system life distribution is described by the branching representation

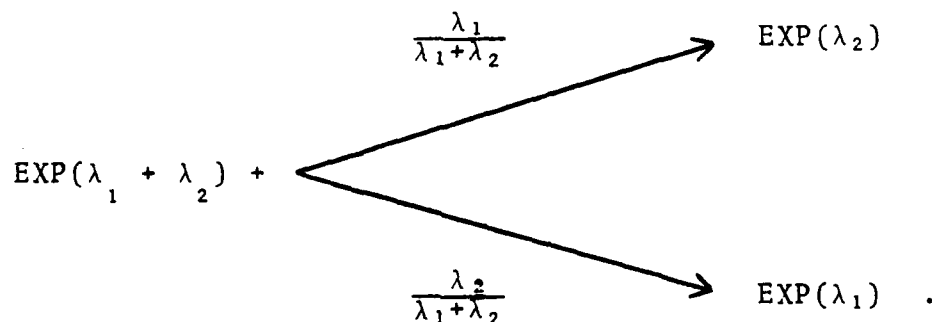

Using the MIX notation this life distribution is $\text{EXP}(\lambda_1 + \lambda_2) + \text{MIX}[(\frac{\lambda_1}{\lambda_1 + \lambda_2})\text{EXP}(\lambda_2), (\frac{\lambda_2}{\lambda_1 + \lambda_2})\text{EXP}(\lambda_1)]$.

The survival function for this distribution is

$$\bar{F}(t) = e^{-(\lambda_1 + \lambda_2)t} + \int_0^t \left[\frac{\lambda_1}{\lambda_1 + \lambda_2} e^{-\lambda_2(t-s)} + \frac{\lambda_2}{\lambda_1 + \lambda_2} e^{-\lambda_1(t-s)} \right] [(\lambda_1 + \lambda_2) e^{-(\lambda_1 + \lambda_2)s}] ds.$$

Applying techniques used previously the survival function becomes

$$\begin{aligned} \bar{F}(t) &= e^{-(\lambda_1 + \lambda_2)t} + e^{-\lambda_2 t} \int_0^t \lambda_1 e^{-\lambda_1 s} ds + e^{-\lambda_1 t} \int_0^t \lambda_2 e^{-\lambda_2 s} ds \\ &= e^{-(\lambda_1 + \lambda_2)t} + e^{-\lambda_2 t} (1 - e^{-\lambda_1 t}) + e^{-\lambda_1 t} (1 - e^{-\lambda_2 t}) \\ &= e^{-\lambda_1 t} + e^{-\lambda_2 t} - e^{-(\lambda_1 + \lambda_2)t}. \end{aligned}$$

This demonstrates that this MIX notation does represent the parallel system's survival function

$$F(t) = F_1(t) + F_2(t) - F_1(t)F_2(t).$$

2. Distributive Property

The MIX notation has an algebraic distributive property. Notationally we have

$$D_3 + \text{MIX}(p_1 D_1, p_2 D_2) = \text{MIX}[p_1 (D_1 + D_3), p_2 (D_2 + D_3)].$$

A graphic representation of the distributive property is shown in figure 5.

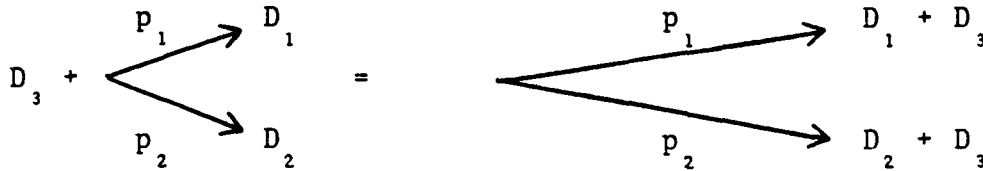

FIGURE 5: DISTRIBUTIVE PROPERTY OF THE MIX NOTATION

For our parallel system example note that

$$D_1 = \text{EXP}(\lambda_2), D_2 = \text{EXP}(\lambda_1), p_1 = \frac{\lambda_1}{\lambda_1 + \lambda_2}, p_2 = \frac{\lambda_2}{\lambda_1 + \lambda_2},$$

and $D_3 = \text{EXP}(\lambda_1 + \lambda_2)$. Using these values we see that

$$\text{EXP}(\lambda_1 + \lambda_2) + \text{MIX}\left[\left(\frac{\lambda_1}{\lambda_1 + \lambda_2}\right)\text{EXP}(\lambda_2), \left(\frac{\lambda_2}{\lambda_1 + \lambda_2}\right)\text{EXP}(\lambda_1)\right] \text{ is}$$

equivalent to

$$\text{MIX}\left[\left(\frac{\lambda_1}{\lambda_1 + \lambda_2}\right)[\text{EXP}(\lambda_1 + \lambda_2) + \text{EXP}(\lambda_2)], \left(\frac{\lambda_2}{\lambda_1 + \lambda_2}\right)[\text{EXP}(\lambda_1 + \lambda_2) + \text{EXP}(\lambda_1)]\right].$$

Note that this is of the form $\text{MIX}(p_1 D_1, p_2 D_2)$.

The latter MIX notation, which combines known distributions, is easier to use computationally than the MIX notation previously given. Utilizing the known distribution of $\text{EXP}(\lambda_1) + \text{EXP}(\lambda_2)$, which has the survival function

$$\bar{F}(t) = \frac{\lambda_1 e^{-\lambda_2 t} - \lambda_2 e^{-\lambda_1 t}}{\lambda_1 - \lambda_2},$$

we can easily convert our MIX notation to determine the parallel system's life distribution.

Substituting this survival function into our MIX notation for the parallel system we obtain

$$\begin{aligned} \bar{F}(t) = & \left(\frac{\lambda_1}{\lambda_1 + \lambda_2} \right) \left[\frac{(\lambda_1 + \lambda_2) e^{-(\lambda_2)t} - (\lambda_2) e^{-(\lambda_1 + \lambda_2)t}}{(\lambda_1 + \lambda_2) - (\lambda_2)} \right] \\ & + \left(\frac{\lambda_2}{\lambda_1 + \lambda_2} \right) \left[\frac{(\lambda_1 + \lambda_2) e^{-(\lambda_1)t} - (\lambda_1) e^{-(\lambda_1 + \lambda_2)t}}{(\lambda_1 + \lambda_2) - (\lambda_1)} \right]. \end{aligned}$$

By cancelling the λ_1 's in the first term and the λ_2 's in the second term, then dividing both terms by the denominator, $(\lambda_1 + \lambda_2)$, the survival function reduces to that of the simple parallel system

$$\bar{F}(t) = e^{-\lambda_1 t} + e^{-\lambda_2 t} - e^{-(\lambda_1 + \lambda_2)t}.$$

As seen in the previous section the alternative method of determining the system's survival function takes the general form

$$\bar{F}(t) = \bar{F}_3(t) + \int_0^t p_1 \bar{F}_1(t-s) f_3(s) ds + \int_0^t p_2 \bar{F}_2(t-s) f_3(s) ds.$$

The reliability shorthand methodology would appear to be preferable.

3. A Standby System Having one Active and a Possible Spare Component

An active component, A, is replaced when it fails by a spare component, S, with probability p. The system has an active component time to failure $T_1 \sim \text{EXP}(\lambda)$, a spare component time to failure $T_2 \sim \text{EXP}(\lambda)$, and T_1, T_2 are independent.

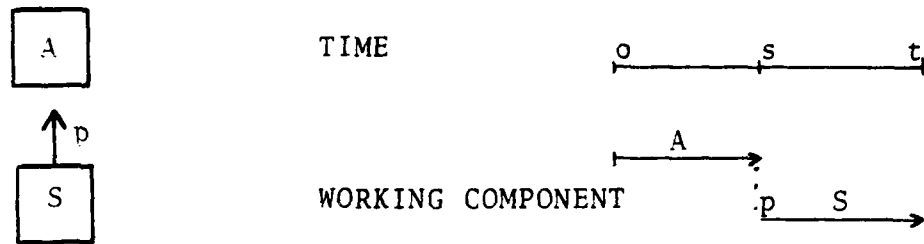

FIGURE 6: A SINGLE ACTIVE COMPONENT POSSIBLY HAVING ONE SPARE COMPONENT

The life of the system is $T = T_1$ with probability $1-p$, or it is $T = T_1 + T_2$ with probability p . The shorthand method of determining the system's life distribution is to view the survival function as a combination of two possible distributions. If no switchover occurs the life T could be T_1 having $\bar{F}_1(t) = e^{-\lambda t}$, or if switchover occurs T could be $T_1 + T_2$ having $\bar{F}_2(t) = (1 + \lambda t)e^{-\lambda t}$. The survival functions $\bar{F}_1(t)$ and $\bar{F}_2(t)$ occur with probabilities $1-p$ and p , respectively. The life distribution is a mixture of the possible distributions where

$$\bar{F}(t) = (1 - p) \bar{F}_1(t) + p\bar{F}_2(t).$$

Thus the system's survival function is

$$\begin{aligned} \bar{F}(t) &= (1-p)e^{-\lambda t} + p(1+\lambda t)e^{-\lambda t} \\ &= e^{-\lambda t} - pe^{-\lambda t} + pe^{-\lambda t} + p\lambda te^{-\lambda t} \\ &= e^{-\lambda t} + p\lambda te^{-\lambda t} \\ &= (1+p\lambda t)e^{-\lambda t}. \end{aligned}$$

The alternate method of determining the life distribution of the system is to derive its survival function in

terms of its possible ways of mission success. The original component could survive to time t with no spare component required, or the original component could fail at some intermediate time s . The spare component then replaces the original component with probability p , and it must live from time s to time t to successfully complete the mission. The system's survival function is then

$$\begin{aligned}
 \bar{F}(t) &= e^{-\lambda t} + \int_0^t p e^{-\lambda(t-s)} \lambda e^{-\lambda s} ds \\
 &= e^{-\lambda t} + \int_0^t p e^{-\lambda t} e^{\lambda s} \lambda e^{-\lambda s} ds \\
 &= e^{-\lambda t} + p e^{-\lambda t} \int_0^t \lambda ds \\
 &= e^{-\lambda t} + p e^{-\lambda t} (\lambda t) \\
 &= (1 + p\lambda t) e^{-\lambda t}.
 \end{aligned}$$

Using the MIX notation we need only write

$$\text{MIX}[(1-p)\text{EXP}(\lambda), p(\text{EXP}(\lambda) + \text{EXP}(\lambda))].$$

the graphic representation is

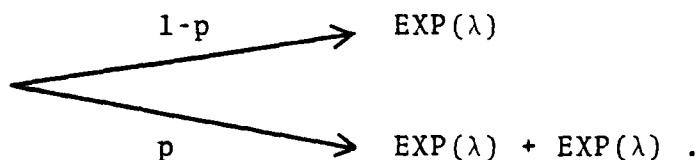

The convenience of the shorthand methodology is again demonstrated.

B. DEGENERACY AT ZERO

Let ZERO be the name for the distribution of a random variable that is degenerate at zero. If $p[T_0=0] = 1$, then we say T_0 has the distribution ZERO, or $T_0 \sim \text{ZERO}$. The survival function for T_0 is as shown in Figure 7.

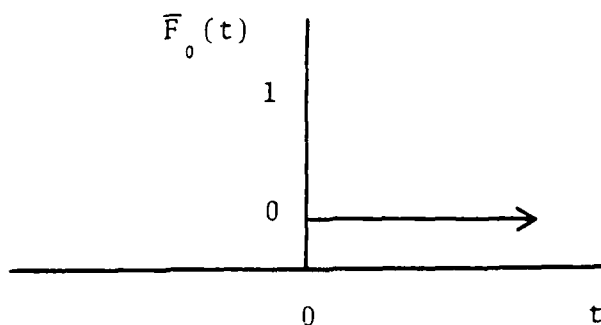

FIGURE 7: SURVIVAL FUNCTION OF THE ZERO DISTRIBUTION

The notion of a ZERO distribution compliments the MIX notation. Assume D_1 is the distribution of a nonnegative random variable T_1 which has the survival function $\bar{F}_1(t)$ and the density $f_1(t)$, where $t \geq 0$. We can then visualize the survival of a component as a combination of $\bar{F}_1(t)$ and $\bar{F}_0(t)$. The survival function is

$$\bar{F}(t) = \bar{F}_1(t) + \int_0^t \bar{F}_0(t-s) f_1(s) ds.$$

Since $\bar{F}_0(t-s) = 0$ for the ZERO distribution, the survival function, $\bar{F}(t)$, is simply $\bar{F}_1(t)$. The ZERO distribution adds nothing to another distribution's density, $D_1 + \text{ZERO} = D_1$.

In the MIX notation we could have $\text{MIX}(pD_1, (1-p)\text{ZERO})$ represent the survival function of a distribution. This would be graphically represented as

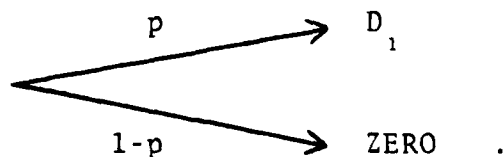

The survival function for this notation is

$$\begin{aligned}\bar{F}(t) &= p \bar{F}_1(t) + (1-p)\bar{F}_0(t) \\ &= p \bar{F}_1(t) + (1-p)(0) \\ &= p \bar{F}_1(t)\end{aligned}$$

The probability p need not be 1 since a system may not work when it is turned on.

For an example of the ZERO distribution's utilization, let us take the standby system composed of a single active component having a spare component for replacement. In section II-A we saw that T was T_1 with probability $1-p$, or T was $T_1 + T_2$ with probability p . In our MIX notation this would be

$$\text{MIX}(p[\text{EXP}(\lambda) + \text{EXP}(\lambda)], (1-p)[\text{EXP}(\lambda)]).$$

If it were not for the ZERO distribution our distributive property would not hold. With the ZERO distribution this MIX notation can be reexpressed as

$$\text{EXP}(\lambda) + \text{MIX}[p\text{EXP}(\lambda), (1-p)\text{ZERO}].$$

Figure 8 graphically represents this equivalence, keeping in mind that $\text{EXP}(\lambda) + \text{ZERO} = \text{EXP}(\lambda)$.

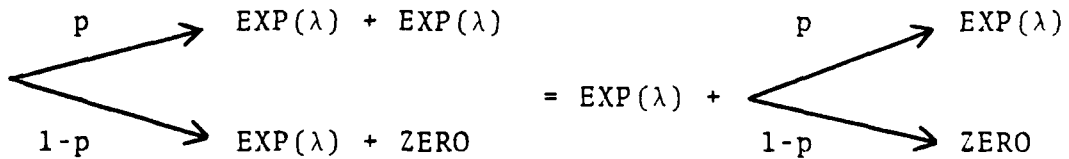

FIGURE 8: DISTRIBUTIVE PROPERTY INCORPORATING THE ZERO DISTRIBUTION

IV. SUMMARY

By learning a simple style of notation and applying it to the survivability of a system, the reliability practitioner can determine the life distribution of the system with non-calculus mathematics.

Appendix A is provided as a start for a ready reference catalogue of systems and their reliability shorthand.

Through the use of computers we can reduce the burden of calculating the survival functions for many systems. Two of the general reliability shorthand cases have been programmed for the Ti-59 and they are presented in Appendix B. The examples provided in that section will demonstrate the computational convenience of the shorthand methodology.

The total scope and depth of the reliability shorthand methodology is yet to be investigated. Computationally, cases requiring the convolution of identical failure rates and distinct failure rates both have known survival function algorithms. Further study is required to determine if there is a useable algorithm which will permit the combination of both cases. This paper was designed to introduce this concept and its known properties to those already familiar with reliability. After seeing the convenience and benefit of the reliability shorthand methodology it is hoped the reader's interest will be further stimulated.

APPENDIX: A

This section contains several examples of the more common systems and their associated reliability shorthand. The format facilitates the addition of other systems in order to build a more thorough ready reference catalogue.

SYSTEM:

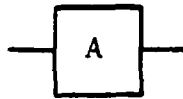

SHORTHAND: EXP(λ)

SURVIVAL FUCTION: $\bar{F}(t) = e^{-\lambda t}$

DESCRIPTION:

A single active component having an exponential life distribution.

SYSTEM:

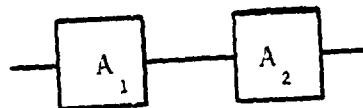

SHORTHAND: $\text{EXP}(\lambda_1 + \lambda_2)$

SURVIVAL FUNCTION: $\bar{F}(t) = e^{-(\lambda_1 + \lambda_2)t}$

DESCRIPTION:

A two component series system which requires both components to function for the system to survive.

SYSTEM:

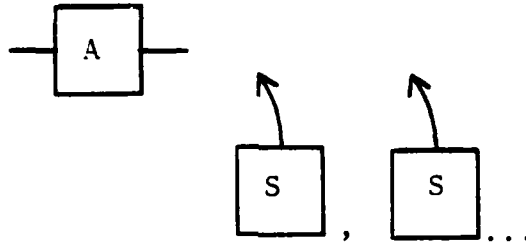

SHORTHAND: $EXP_1(\lambda) + EXP_2(\lambda) + \dots + EXP_n(\lambda)$

SURVIVAL FUNCTION:
$$\bar{F}(t) = \sum_{i=1}^n \frac{(\lambda t)^{i-1}}{(i-1)!} e^{-\lambda t}$$

DESCRIPTION:

A single active component has $n-1$ identical spare components. As each component fails it is replaced by a new identical component which allows the system to survive. The system has n consecutive $EXP(\lambda)$ lives.

SYSTEM:

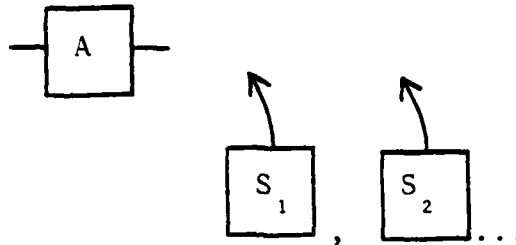

SHORTHAND: $\text{EXP}(\lambda_1) + \text{EXP}(\lambda_2) + \dots + \text{EXP}(\lambda_n)$

SURVIVAL FUNCTION:
$$\bar{F}(t) = \sum_{i=1}^n \frac{\prod_{j \neq i} \lambda_j}{\prod_{j \neq i} (\lambda_j - \lambda_i)} e^{-\lambda_i t}$$

DESCRIPTION:

A single active component has $n-1$ dissimilar spare components. As each component fails it is replaced by a new component which allows the system to survive. Each of the n components has a different failure rate, and the system has n consecutive $\text{EXP}(\lambda_i)$ lives.

SYSTEM:

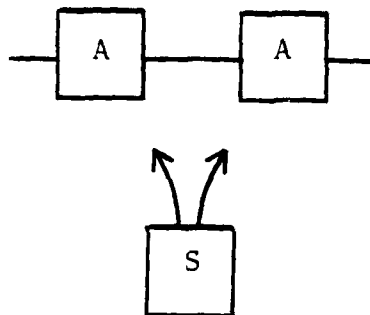

SHORTHAND: $\text{EXP}(2\lambda) + \text{EXP}(2\lambda)$

SURVIVAL FUNCTION: $\bar{F}(t) = (1 + 2\lambda t)e^{-2\lambda t}$

DESCRIPTION:

A series system composed of two identical active components has another identical component available as a spare. The original series system has a $\text{EXP}(2\lambda)$ life. When either component fails and the spare takes its place, the system has a new $\text{EXP}(2\lambda)$ life.

SYSTEM:

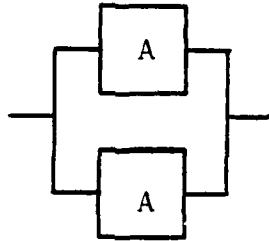

SHORTHAND: $\text{EXP}(2\lambda) + \text{EXP}(\lambda)$

SURVIVAL FUNCTION: $\bar{F}(t) = 2e^{-\lambda t} - e^{-2\lambda t}$

DESCRIPTION:

The parallel system has two identical active components functioning together with an $\text{EXP}(2\lambda)$ life for system survival. When either component fails the surviving component is as if new with an $\text{EXP}(\lambda)$ life. This new component alone functions for system survival.

SYSTEM:

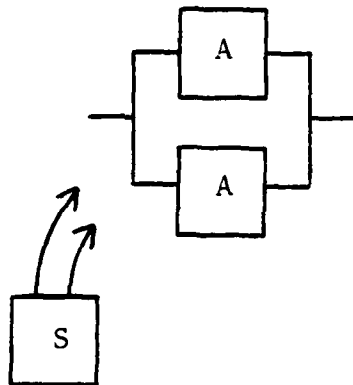

SHORTHAND: $\text{EXP}(2\lambda) + \text{EXP}(2\lambda) + \text{EXP}(\lambda)$

SURVIVAL FUNCTION: $\bar{F}(t) = 4e^{-\lambda t} - 3e^{-2\lambda t} - 2\lambda t e^{-2\lambda t}$

DESCRIPTION:

A parallel system composed of two identical components has a similar component as a spare which will replace the first component that fails. The original system functions with a $\text{EXP}(2\lambda)$ life until a component fails. When it is replaced a new parallel system exists which has a life of $\text{EXP}(2\lambda) + \text{EXP}(\lambda)$.

SYSTEM:

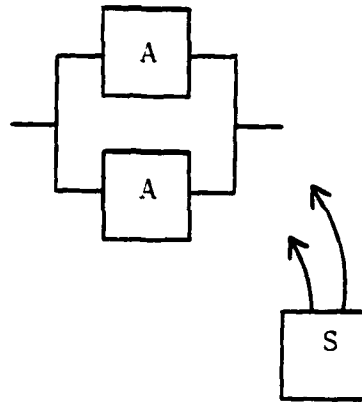

SHORTHAND: $\text{EXP}(2\lambda) + \text{EXP}(\lambda) + \text{EXP}(\lambda)$

SURVIVAL FUNCTION: $F(t) = e^{-2\lambda t} + 2\lambda t e^{-\lambda t}$

DESCRIPTION:

A parallel system composed of two identical components has a similar component as a spare which will replace the last component that fails. The original system functions with an $\text{EXP}(2\lambda) + \text{EXP}(\lambda)$ life until both components have failed. When the last component is replaced the system survives by the new component which has an $\text{EXP}(\lambda)$ life.

APPENDIX: B

INTRODUCTION

There are two general cases in reliability shorthand where the aid of a programmable calculator greatly simplifies the tedious calculation of a system's survival function.

Case one in reliability shorthand is of the form $EXP(\lambda_1) + EXP(\lambda_2) + \dots + EXP(\lambda_n)$, and each of the n failure rates are different. When the system description is of this form, $\sum_{i=1}^n EXP(\lambda_i)$, the survival function is $\bar{F}(t) = \sum_{i=1}^n \frac{\prod_{j \neq i} \lambda_j}{\prod_{j \neq i} (\lambda_j - \lambda_i)} e^{-\lambda_i t}$.

Case two in reliability shorthand is of the form $EXP(\lambda) + EXP_2(\lambda) + \dots + EXP_n(\lambda)$, and each of the n failure rates are identical. When the system description is of this form, $\sum_{i=j}^n EXP_i(\lambda)$, the survival function is $\bar{F}(t) = \sum_{i=j}^n \frac{(\lambda t)^{i-1}}{(i-1)!} e^{-\lambda t}$.

USER PROCEDURES

1. Use any library module and read in side one of the magnetic card.
2. For case one the survival function is found using Label A. Enter t in R_{00} , n in R_{01} , and the n different failure rates in R_{13} through $R_{13} + (n-1)$. The order of the λ_i 's does not matter. Press **[A]** for the system reliability.
3. For case two, the survival function is found using Label B. Enter t in R_{00} , n in R_{01} , and λ in R_{13} . Press **[B]** for the system reliability.

4. The maximum n for case two is not limited. The maximum for case one is limited to 47 due to the partitioning 479.59. Using 92^{nd} OP17 the maximum n can be increased to 77.

LABELS USED

A	A'	sin
B	B'	cos
C	C'	tan
D	D'	
	E'	

STORAGE REGISTER CONTENTS

00	t	08	used
01	n	09	used
02	used	10	used
03	used	11	used
04	used	12	used
06	used	13	λ
07	used	13-59	λ_i

EXAMPLE RUN TIMES

<u>n</u>	<u>Case one - LBL A</u>	<u>Case two - LBL B</u>
1	8 seconds	3 seconds
2	18 seconds	5 seconds
3	34 seconds	7 seconds
4	55 seconds	10 seconds
5	80 seconds	12 seconds

SAMPLE PROBLEMS

CASE ONE:

Reliability shorthand: $EXP(\lambda_1) + EXP(\lambda_2) + EXP(\lambda_3)$

Longhand form:

$$\bar{F}(t) = \frac{\lambda_2 \lambda_3}{(\lambda_2 - \lambda_1)(\lambda_3 - \lambda_1)} e^{-\lambda_1 t} + \frac{\lambda_1 \lambda_3}{(\lambda_1 - \lambda_2)(\lambda_3 - \lambda_2)} e^{-\lambda_2 t} + \frac{\lambda_1 \lambda_2}{(\lambda_1 - \lambda_3)(\lambda_2 - \lambda_3)} e^{-\lambda_3 t}$$

Sample values: $t = 2, n = 3, \lambda_1 = .5, \lambda_2 = .6, \lambda_3 = .7$

Procedure:

1) Enter sample values, $t=2$ STO 00, $n=3$ STO 01, $\lambda_1=.5$ STO 13, $\lambda_2=.6$ STO 14, and $\lambda_3=.7$ STO 15.

2) Press [A] and $\bar{F}(t)$ is displayed. $\bar{F}(t)=.88262530$

CASE TWO:

Reliability shorthand: $EXP_1(\lambda) + EXP_2(\lambda) + EXP_3(\lambda) + EXP_4(\lambda) + EXP_5(\lambda)$

Longhand form:

$$\bar{F}(t) = \left(\frac{(\lambda t)^0}{0!} + \frac{(\lambda t)^1}{1!} + \frac{(\lambda t)^2}{2!} + \frac{(\lambda t)^3}{3!} + \frac{(\lambda t)^4}{4!} \right) e^{-\lambda t}$$

Sample values: $t=2, n=5$, and $\lambda=.5$

Procedure:

1) Enter sample value, $t=2$ STO 00, $n=5$ STO 01, and $\lambda=.5$ STO 13

2) Press [B] and $\bar{F}(t)$ is displayed. $\bar{F}(t)=.9963401532$

FLOWCHART: LABEL A, CASE 1

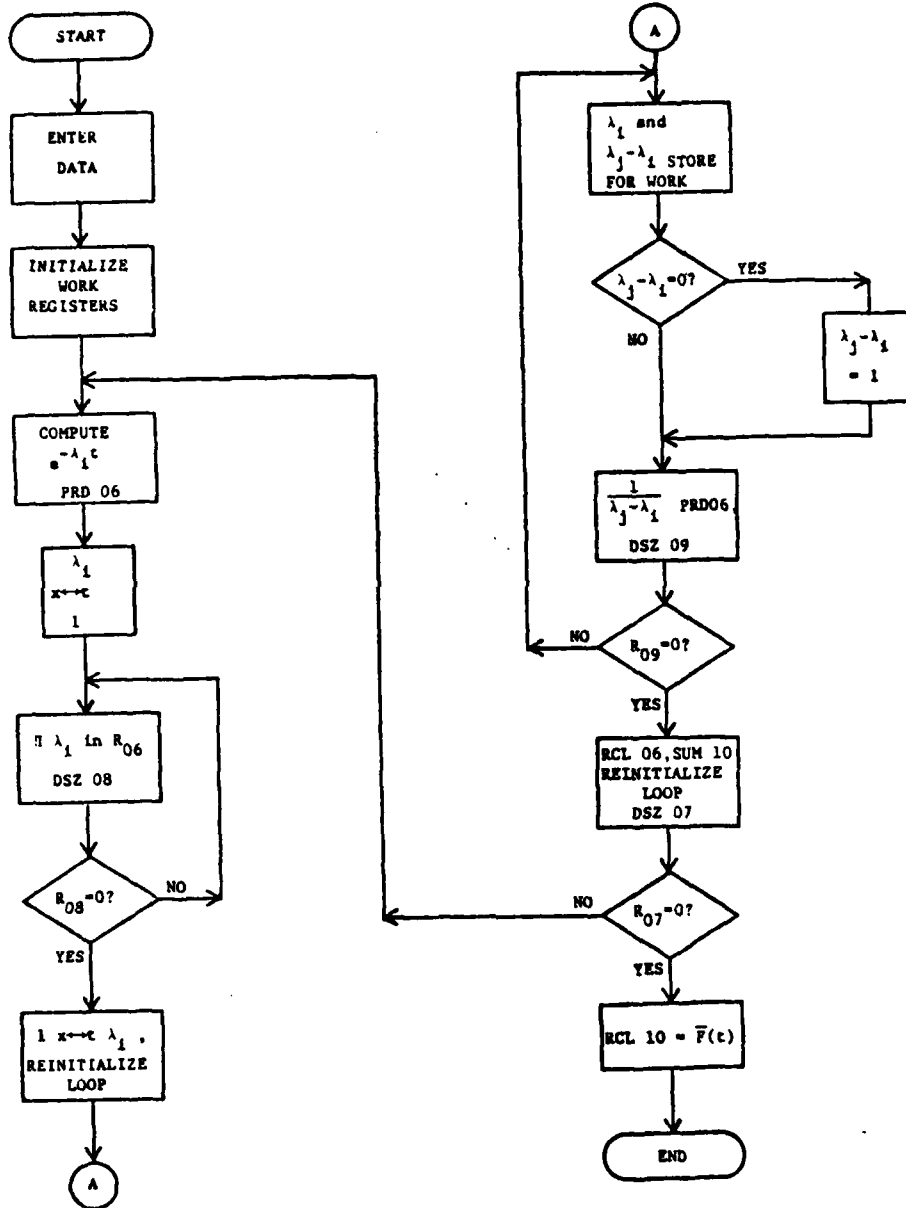

FLOWCHART: LABEL B, CASE 2

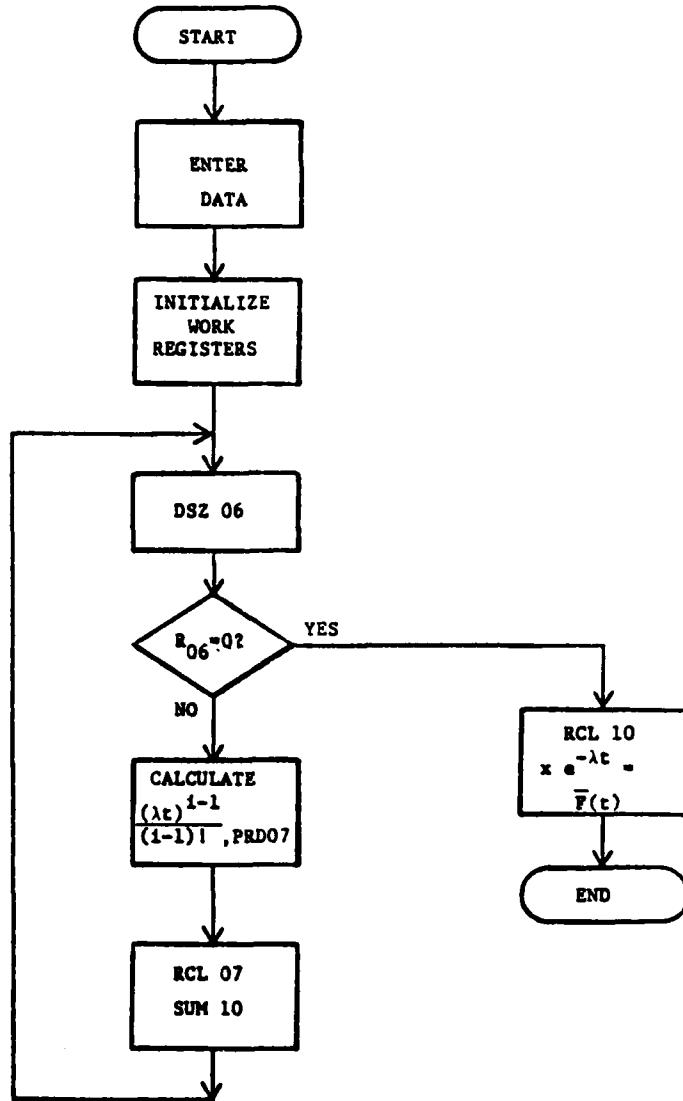

COMPUTER LISTING: LABEL A

001	76	LBL	001	06	06	101	11	E'
002	11	R	002	73	RC+	102	43	RCL
003	01	1	003	03	03	103	12	12
004	22	INV	004	32	XIT	104	35	1/3
005	43	STD	005	01	1	105	49	PRD
006	02	02	006	72	ST-	106	06	06
007	01	1	007	03	03	107	97	DSE
008	42	STD	008	76	LBL	108	05	05
009	02	02	009	17	B'	109	39	COB
010	32	XIT	010	73	RC+	110	78	LBL
011	00	0	011	04	04	111	39	COB
012	42	STD	012	49	FFD	112	97	DSE
013	10	10	013	06	06	113	09	09
014	42	STD	014	97	DSE	114	13	C'
015	11	11	015	04	04	115	43	RCL
016	42	STD	016	38	SIN	116	01	01
017	12	12	017	76	LBL	117	42	STD
018	43	RCL	018	38	SIN	118	09	09
019	01	01	019	97	DSE	119	85	+
020	42	STD	020	08	08	120	01	1
021	07	07	021	17	B'	121	02	2
022	42	STD	022	43	RCL	122	95	=
023	08	08	023	01	01	123	42	STD
024	42	STD	024	42	STD	124	05	05
025	09	09	025	08	08	125	43	RCL
026	85	+	026	85	+	126	06	06
027	01	1	027	01	1	127	44	SUM
028	02	2	028	02	2	128	10	10
029	95	=	029	95	=	129	01	1
030	42	STD	030	42	STD	130	42	STD
031	03	03	031	04	04	131	06	06
032	42	STD	032	00	0	132	97	DSE
033	04	04	033	32	XIT	133	03	03
034	42	STD	034	72	ST+	134	30	TAN
035	05	05	035	03	03	135	76	LBL
036	76	LBL	036	42	STD	136	30	TAN
037	16	A'	037	11	11	137	97	DSE
038	43	RCL	038	76	LBL	138	07	07
039	02	02	039	18	C'	139	16	A'
040	45	Y%	040	73	RC+	140	43	RCL
041	53	C	041	05	05	141	10	10
042	73	RC+	042	75	-	142	92	PTH
043	03	03	043	43	RCL	143	76	LBL
044	34	+/-	044	11	11	144	19	D'
045	65	%	045	35	=	145	01	1
046	43	RCL	046	42	STD	146	42	STD
047	00	00	047	12	12	147	12	12
048	54	?	048	67	EQ	148	61	GTO
049	96	=	049	19	B'	149	10	E'
050	57	FFD	050	78	LBL	150	32	PTH

COMPUTER LISTING: LABEL B

151	76	LBL	193	43	RCL
152	13	B	194	00	00
153	01	1	197	54)
154	22	INV	198	54)
155	23	LNX	199	95	=
156	42	STD	190	92	RTN
157	02	02	191	76	LBL
158	01	1	192	13	C
159	42	STD	193	53	(
160	07	07	194	43	RCL
161	42	STD	195	00	00
162	10	10	196	65	*
163	43	RCL	197	43	RCL
164	01	01	198	13	13
165	42	STD	199	54)
166	06	06	200	55	+
167	76	LBL	201	53	(
168	14	D	202	43	RCL
169	97	DSZ	203	01	01
170	06	06	204	75	-
171	13	C	205	43	RCL
172	43	RCL	206	06	06
173	10	10	207	54)
174	95	=	208	95	=
175	65	*	209	49	PRD
176	53	(210	07	07
177	43	RCL	211	43	RCL
178	02	02	212	07	07
179	45	YZ	213	44	SUM
180	53	(214	10	10
181	43	RCL	215	61	GTO
182	13	13	216	14	D
183	94	47-	217	92	RTN
184	67	*			

BIBLIOGRAPHY

Esary, J.D., Course notes and problem sets for OA4662,
Naval Postgraduate School, Monterey, CA., 1980.

INITIAL DISTRIBUTION LIST

	No. Copies
1. Defense Technical Information Center Cameron Station Alexandria, Virginia 22314	2
2. Library, Code 0142 Naval Postgraduate School Monterey, California 93940	2
3. Department Chairman, Code 55 Department of Operations Research Naval Postgraduate School Monterey, California 93940	1
4. Professor J.D. Esary, 55Ey Naval Postgraduate School Monterey, California 93940	1
5. Professor R.N. Forrest, 55Fo Naval Postgraduate School Monterey, California 93940	1
6. LCDR John J. Repicky, Jr. USN 17815 Brazil Road Cleveland, Ohio 44119	1

