

AD-A102 566

RIA-81-U791

#102 566

HDL-TR-1961

June 1981

TECHNICAL  
LIBRARY



## Two-Channel Telemeter for Use in a 3-in. Spin Air Gun

by Floyd Allen



U.S. Army Electronics Research  
and Development Command  
**Harry Diamond Laboratories**

Adelphi, MD 20783

Approved for public release; distribution unlimited.

The findings in this report are not to be construed as an official Department of the Army position unless so designated by other authorized documents.

Citation of manufacturers' or trade names does not constitute an official indorsement or approval of the use thereof.

Destroy this report when it is no longer needed. Do not return it to the originator.



UNCLASSIFIED

SECURITY CLASSIFICATION OF THIS PAGE(When Data Entered)

20. ABSTRACT (Cont'd)

components for controlling the battery load program, i.e., applying and removing loads at fixed time intervals, rather than using steady-state loads, for the full flight. Potential usefulness for this telemeter system extends to other applications which may require remote voltage monitoring for long periods of time.

UNCLASSIFIED

2 SECURITY CLASSIFICATION OF THIS PAGE(When Data Entered)

## CONTENTS

|                                    | <u>Page</u> |
|------------------------------------|-------------|
| 1. INTRODUCTION.....               | 5           |
| 2. DESIGN PROCEDURE.....           | 7           |
| 2.1 Transmitter.....               | 8           |
| 2.2 Subcarrier Oscillators.....    | 8           |
| 2.3 Amplifier/Mixer.....           | 8           |
| 2.4 Load Simulator.....            | 8           |
| 2.5 Auxiliary Supply.....          | 10          |
| 2.6 Antenna Assembly.....          | 10          |
| 3. TELEMETRY PROJECTILE.....       | 10          |
| 4. SYSTEM PERFORMANCE.....         | 16          |
| 5. SUMMARY.....                    | 18          |
| 6. RECOMMENDED IMPLEMENTATION..... | 18          |
| ACKNOWLEDGEMENTS.....              | 19          |
| DISTRIBUTION.....                  | 21          |

## FIGURES

|   |    |
|---|----|
| 1 Artillery simulator.....                                    | 5  |
| 2 Three-in. artillery simulator spin catcher system.....      | 6  |
| 3 Block diagram of spin air-gun telemeter.....                | 7  |
| 4 Load profile timing diagram.....                            | 9  |
| 5 Logic circuit block diagram.....                            | 9  |
| 6 Schematic diagram of fuze load simulator and telemeter..... | 11 |
| 7 Load simulator board.....                                   | 12 |
| 8 Telemeter board, including logic circuits.....              | 12 |

FIGURES (Cont'd)

|   | <u>Page</u> |
|---|-------------|
| 9 Auxiliary supply for telemeter.....                                 | 13          |
| 10 Details of parallel-plate antenna in 3-in.<br>metal nose cone..... | 13          |
| 11 Parallel-plate antenna and radiation pattern.....                  | 14          |
| 12 Three-in. spin air gun telemetry projectile.....                   | 15          |
| 13 Exploded view of telemeter.....                                    | 15          |
| 14 Telemeter projectile.....  | 16          |
| 15 Block diagram of receiving equipment.....                          | 17          |
| 16 Spin air-gun load sequence for PS416 battery power supply.....     | 17          |
| Table 1 Frequency Limits of Subcarrier Oscillators.....               | 8           |

## 1. INTRODUCTION

Laboratory testing is often a valuable adjunct to actual weapons firings in the evaluation of ammunition components. HDL's 3-in. air gun or artillery simulator permits laboratory or factory testing of batteries and other devices under combinations of linear acceleration, angular acceleration, and sustained spin quite similar to those encountered in rifled weapons. The simulator test allows for more testing of lot samples for acceptance at far lower cost than expensive field testing.

The artillery simulator is shown conceptually in figure 1. The actual 3-in. artillery simulator is shown in figure 2. It consists of a 98-ft long, 3-in. ID barrel that is used to fire a projectile into a second 3-in. ID barrel, 41 in. long, rotating at a desired spin rate. In this rotating tube, the projectile is simultaneously decelerated and brought up to spin (in a manner simulating actual gun-fire) by impact with an ejectable momentum exchange mass. The characteristics of this mass are adjusted so that the projectile remains in the spinning tube after impact. Environments simulated include velocities up to 500 ft/s, setback forces of 1,000 to 20,000 g, and spins up to 200 rps.

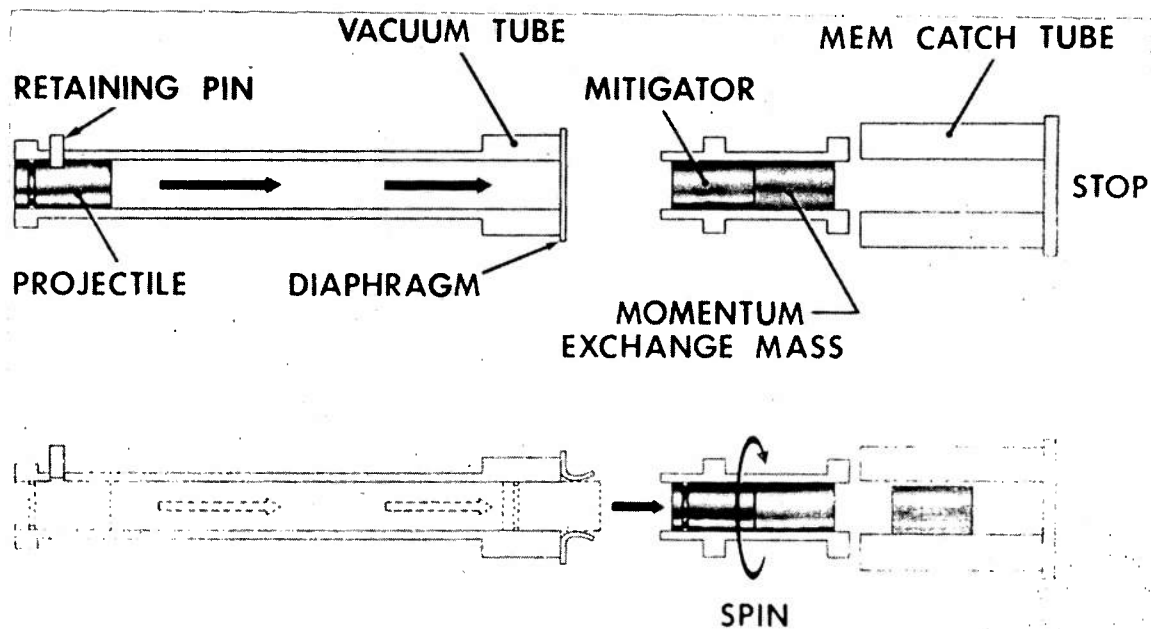

Figure 1. Artillery simulator.

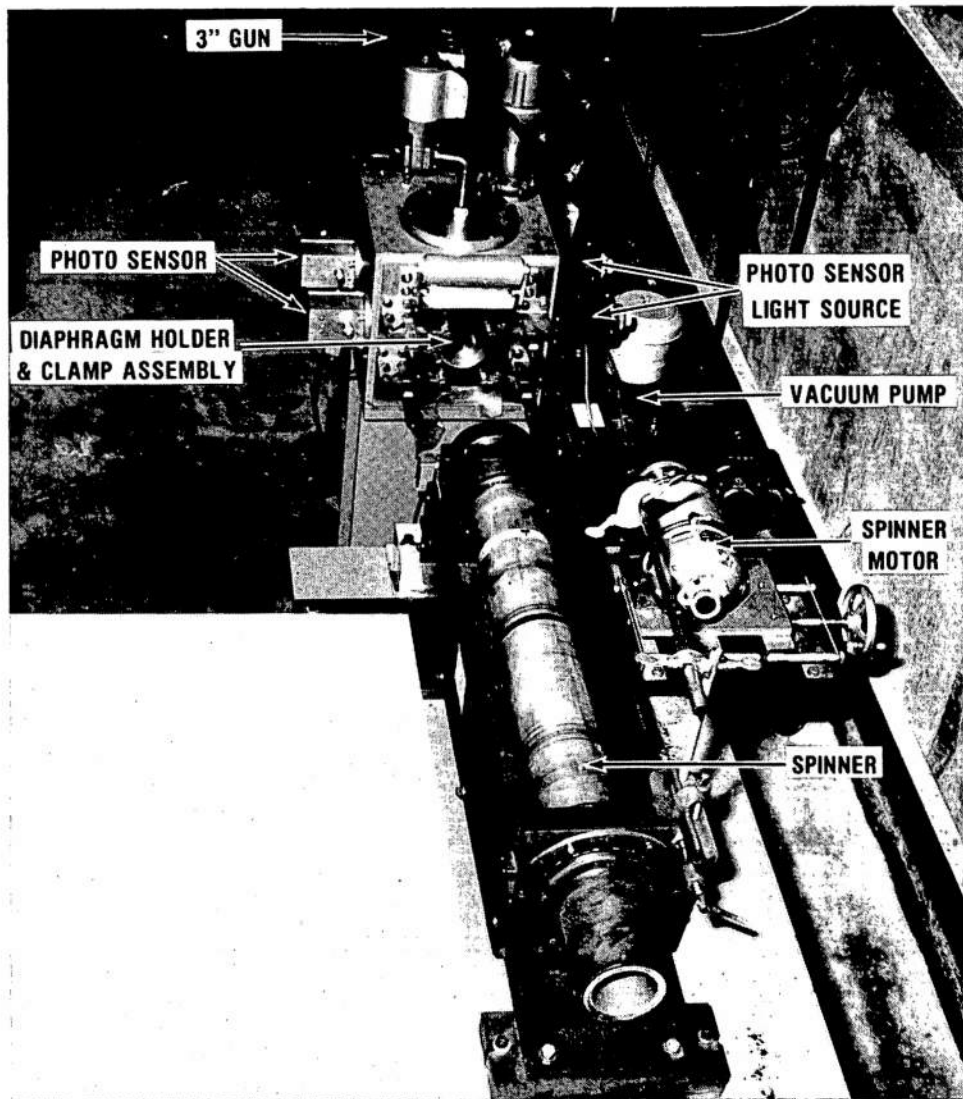

Figure 2. Three-in. artillery simulator spin catcher system.

Typical hardware slip-ring read-out systems, however, tend to introduce intolerable electrical noise during spin and prevent reliable measurement of voltage and current. Also, in all centrifugally actuated contacts, there is a time delay between missile impact and the start of the read-out. This delay makes it difficult to measure the voltage rise time of reserve batteries.

The recording of more than one voltage in slip-ring systems requires a many-segmented spin tube and associated polarity-inversion circuitry. Additionally, the large-diameter slip-rings that would be required for this application (approximately 5 in. in diameter) cannot meet the 300-rps spin requirement.

The use of rf telemetry read-out has the following advantages:

a. There is negligible system electrical noise associated with the outputs.

b. There is instantaneous response between battery activation and voltage read-out.

c. Telemetry read-out avoids the problems that arise in slip-ring systems when more than one voltage is to be recorded.

d. Additional data channels can be added as needed with a minimum of change in the basic system.

Using telemetry is a standard way to monitor the in-flight performance of projectile components, so telemetry is a convenient solution to the read-out problem.

## 2. DESIGN PROCEDURE

The telemeter described here has many features in common with airborne telemetry systems. Commercial subsystems have been fully used, insofar as practical. The block diagram of the complete telemeter is shown in figure 3. The test battery voltage is divided down by the divider network,  $R_1$  and  $R_2$ , before appearing at the input to the 40-kHz subcarrier oscillator (SCO). The 22-kHz SCO measures the battery current by taking the voltage drop across the 0.5-ohm monitor resistor. The composite signal is then broadcast by the transmitter. The receiving antenna is near the entrance to the spinning tube. The received signal is fed to another location over coaxial cable, to be demodulated and recorded.

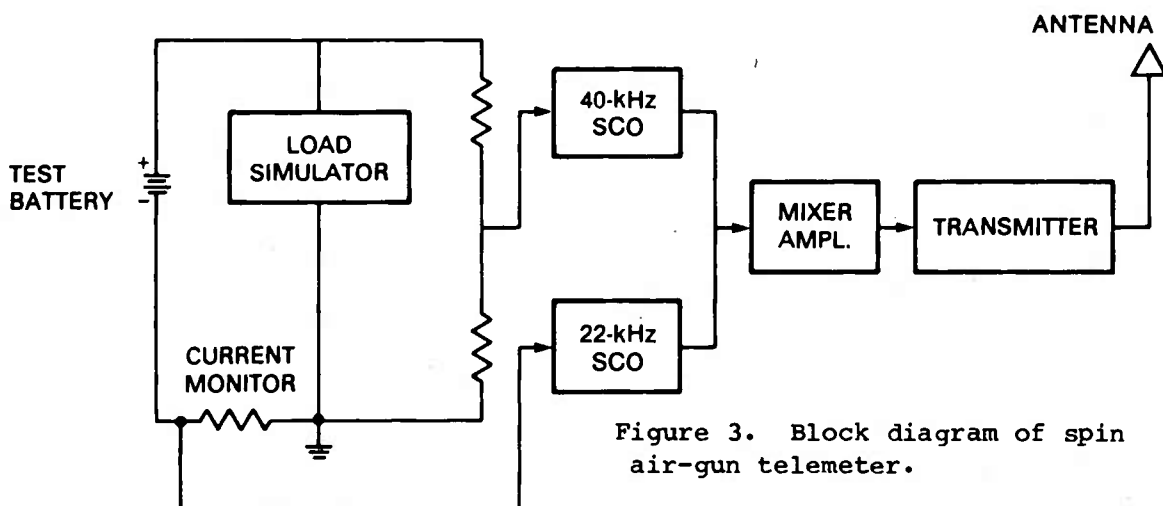

Figure 3. Block diagram of spin air-gun telemeter.

## 2.1 Transmitter

The "L" band transmitter, a commercial device, is designed for operation at 1510 MHz. It is ideally suited for use in high shock environments, such as artillery and other gun-launched applications. It has an output of 150 mW (minimum) and also provides excellent frequency stability.

## 2.2 Subcarrier Oscillators

The 22- and 40-kHz SCO's are used to monitor test battery current and voltage, respectively. The input voltage range of each device is 0 to 5 Vdc, which causes a shift in frequency of the 22-kHz SCO of 18.7 to 25.3 kHz, and of the 40-kHz SCO of 34 to 46 kHz (table 1). The change in frequency of the SCO's is a linear function of input voltage.

TABLE 1. FREQUENCY LIMITS OF SUBCARRIER OSCILLATORS

| IRIG channel | Center frequency (Hz) | Lower deviation limit (Hz) | Upper deviation limit (Hz) | Nominal frequency response (Hz) |
|--------------|-----------------------|----------------------------|----------------------------|---------------------------------|
| A            | 22,000                | 18,700                     | 25,300                     | 660                             |
| C            | 40,000                | 34,000                     | 46,000                     | 1200                            |

## 2.3 Amplifier/Mixer

The amplifier/mixer stage combines the outputs of the SCO's and modulates the transmitter with the composite signal. The amplifier has a linear gain of 6 which is sufficient to modulate the transmitter.

## 2.4 Load Simulator

The current drain imposed by an artillery fuze on its battery power supply is rarely constant throughout flight. In order to provide a more realistic match between the actual fuze needs and laboratory test procedures for batteries, the XM735 fuze group established a load sequence. This sequence called for the battery to meet certain voltage specifications when the load profile of figure 4 was imposed on it. Figure 5 shows a simplified block diagram of the logic circuitry, which provides timing signals that sequentially switch in the Z, PRE-ARM, and

ARM loads. When the test battery is activated, a regulated +10 V is derived from it in order to operate the logic circuits. Logic turn-on is delayed by the 60-ms turn-on delay. At the end of this delay, a binary counter, with its integral oscillator, starts and provides an enabling signal to the memory/timing circuit. A binary counter, with its integral oscillator, starts and provides an enabling signal to the memory/timing circuit.

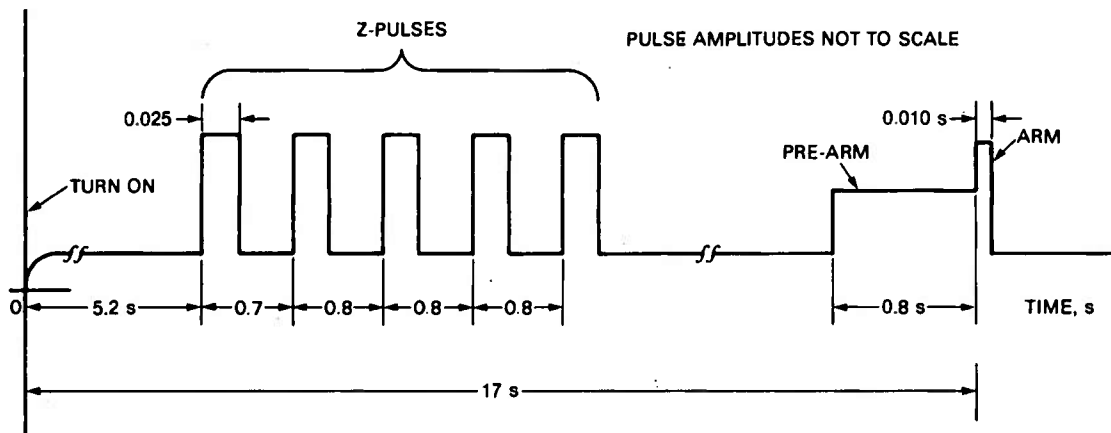

Figure 4. Load profile timing diagram.

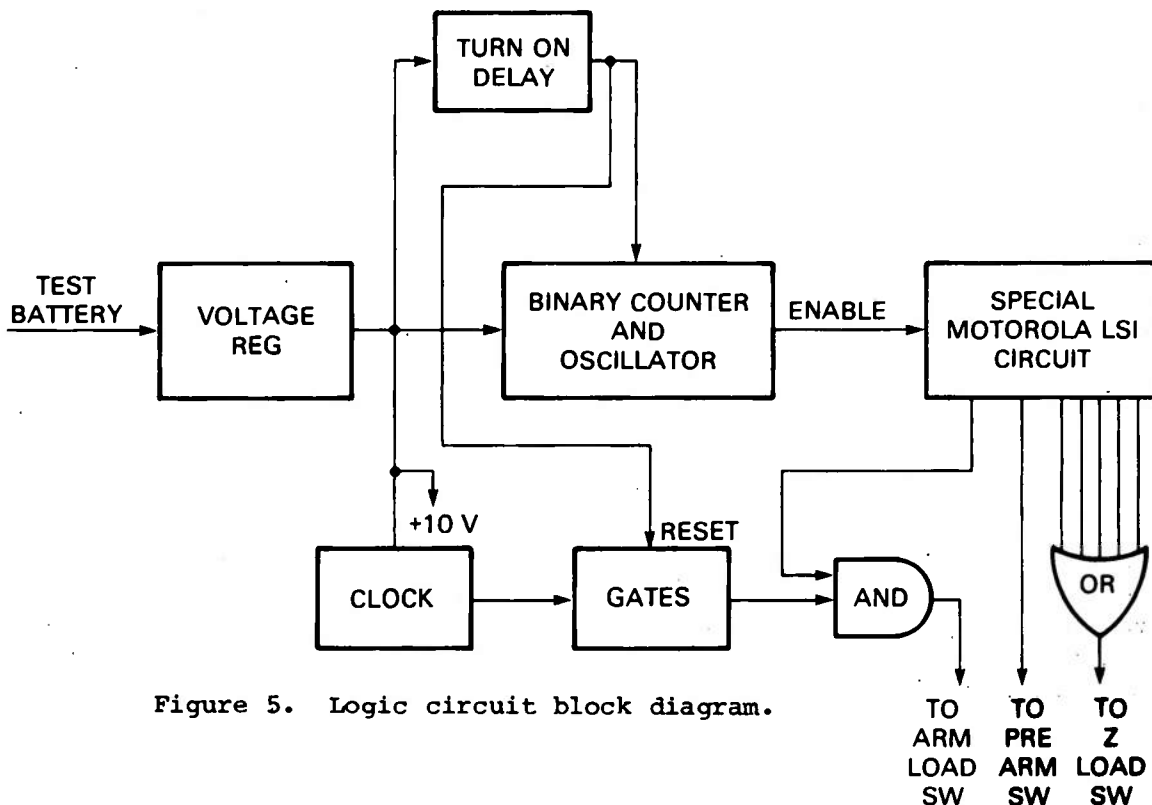

Figure 5. Logic circuit block diagram.

Depending on the selection of the binary counter tap, the ARM time from the memory/timing circuit will be determined. The Z pulse time will occur approximately 11 s before the ARM time. These times are shown in the timing diagram of figure 4. The clock has a 0.1-s period; when the memory/timing circuit is clocked with this period and enabled, the pulse widths and spacings are determined. The Z, PRE-ARM, and ARM signals are then fed to the appropriate load switches, as shown in figure 5. The detailed circuit diagram of the fuze load simulator is shown in figure 6 (p 11). Photographs of the circuit boards that make up the load simulator and telemeter are shown in figures 7 and 8 (p 12).

## 2.5 Auxiliary Supply

The auxiliary supply is an epoxy-potted module consisting of 10 series-connected size 1/2 AA lithicells (30 V) that is regulated down to 24 V by a standard three-terminal voltage regulator. The regulated 24-V output powers the transmitter, the SCO's, and the amplifier/mixer. The supply is activated by shorting pins 1 and 2, thereby gating the silicon-controlled rectifier on. The supply can be turned off at the conclusion of the test by shorting pins 2 and 3. Figure 9 (p 13) is a circuit diagram of the supply showing its turn-on and turn-off features.

## 2.6 Antenna Assembly

The telemeter is required to transmit out of a 20-in. long metal spin tube. Although the parallel-plate antenna used in this system was designed for another application (HDL design, U.S. Patent 3,943,520), its forward-looking radiation pattern makes it desirable for radiating the telemetry signal down the tube. The antenna, which was designed for use in a nose cone, is fed from a coaxial line at the center of the planar surface of the wedge, approximately a quarter wavelength from the base. Construction details and radiation patterns are shown in figures 10 and 11 (p 13 and 14).

## 3. TELEMETRY PROJECTILE

The major requirements for air-gun projectiles are low weight and good mechanical strength, in order to withstand repeated firings. Furthermore, the front end must be solid, because it forms a plug to seal the accelerating tube during evacuation of air by a mechanical vacuum pump. The propelling force for the projectile in the accelerating tube is the differential of air pressure between the evacuated tube and the atmosphere behind the projectile.

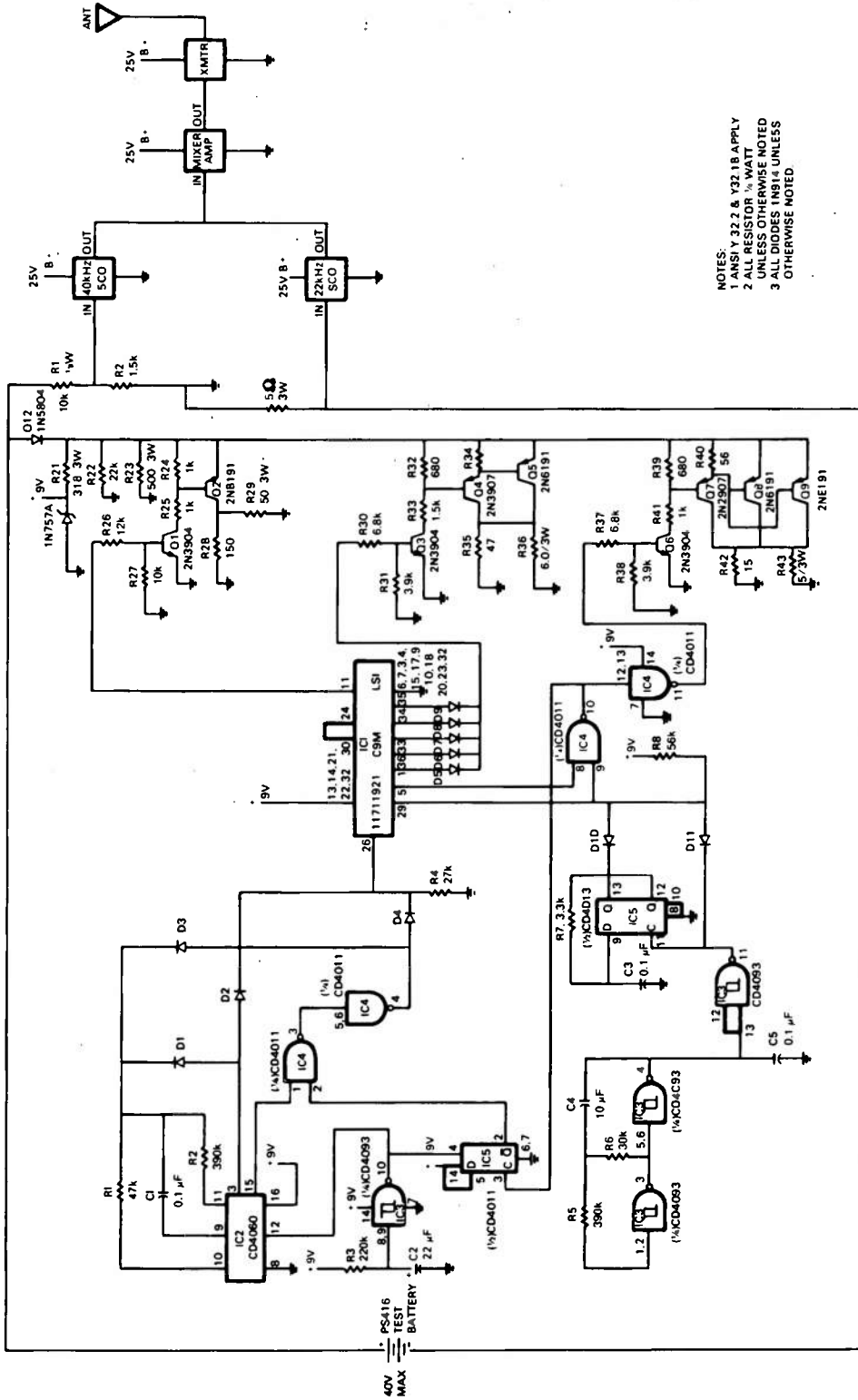

NOTES:  
 1 ANS Y 32.2 & Y32.18 APPLY  
 2 ALL RESISTOR 1/4 WATT  
 UNLESS OTHERWISE NOTED  
 3 ALL DIODES 1N914 UNLESS  
 OTHERWISE NOTED

Figure 6. Schematic diagram of fuze load simulator and telemeter.

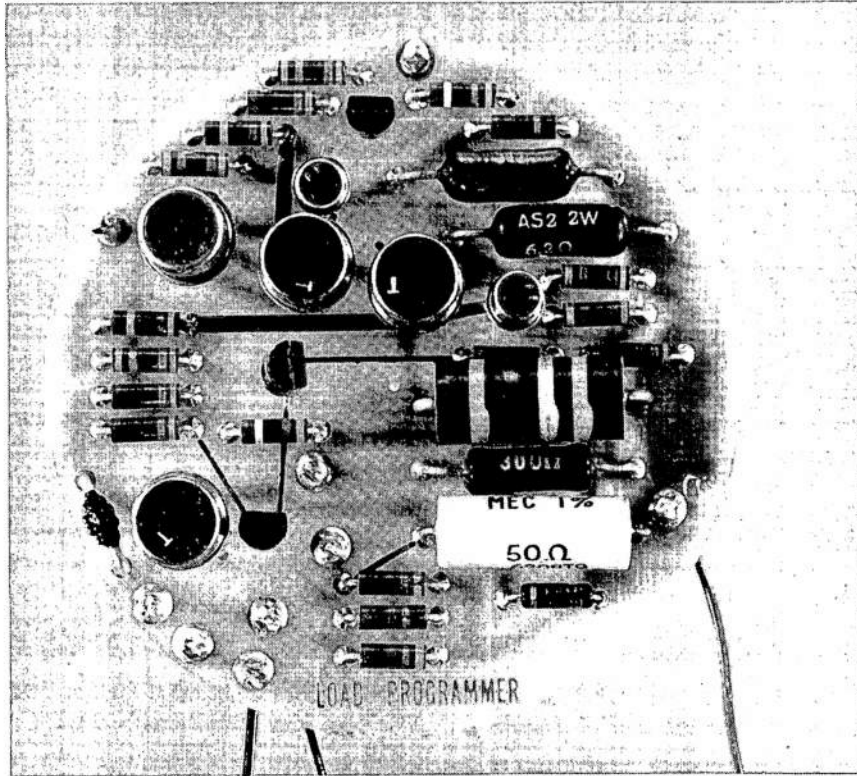

Figure 7. Load simulator board.

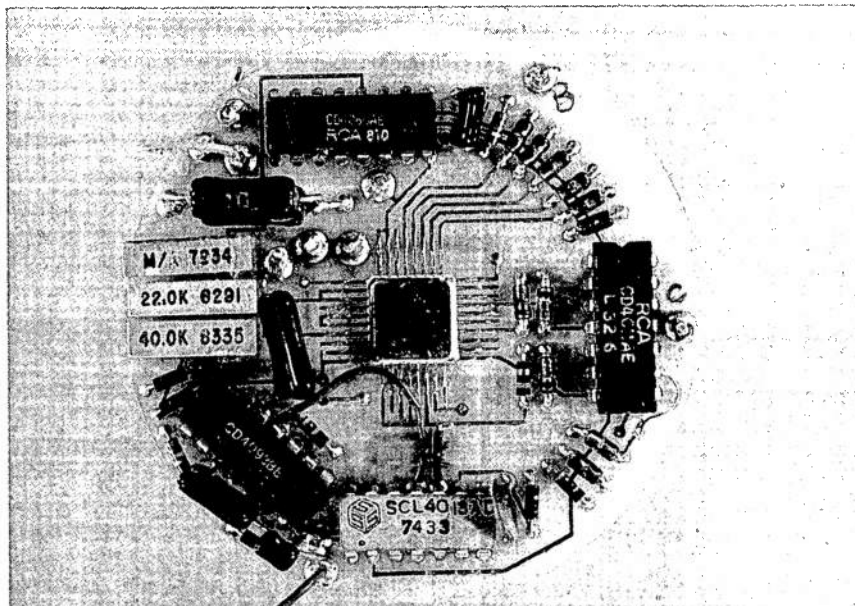

Figure 8. Telemeter board, including logic circuits.

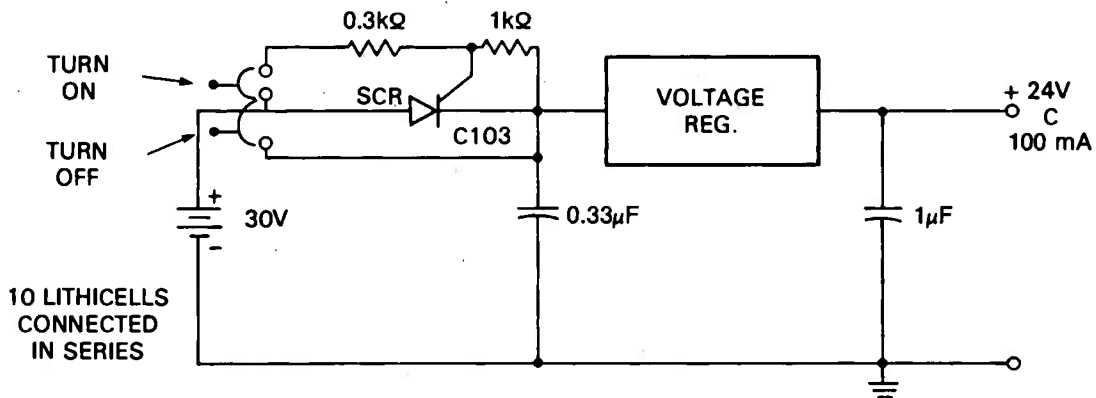

Figure 9. Auxillary supply for telemetry.

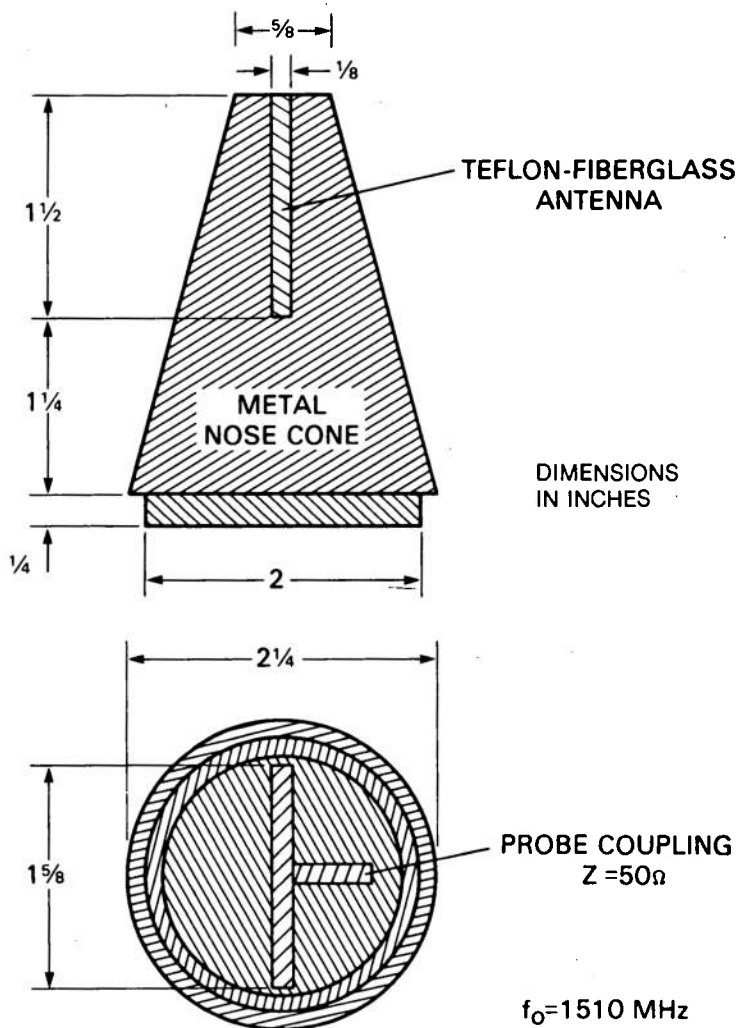

Figure 10. Details of parallel-plate (wedge) antenna in 3-in. metal nose cone.

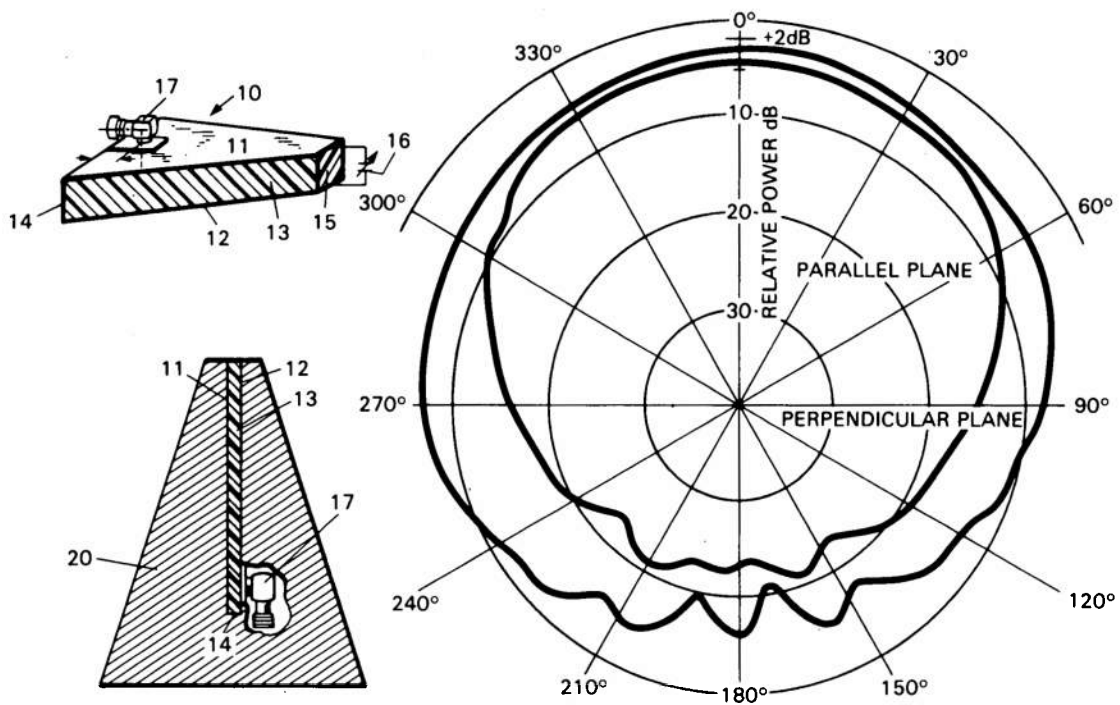

Figure 11. Parallel-plate (wedge) antenna and radiation pattern.

The complete telemeter assembly is contained in an aluminum sleeve approximately 8 in. long and 3 in. in diameter, with a 2-5/8 in. diameter cavity. An additional 3-in. cone-shaped antenna is on the back of the projectile (fig. 12). The transmitter, the load simulator and telemeter, and auxiliary supply modules are all epoxied in the sleeve. Three screws spaced along the inside diameter of the sleeve prevent relative rotation of the subassemblies. Interconnections between modules are by hard wire. The test battery is wired into a phenolic holder that is equipped with banana plugs, and the test battery holder is plugged into two insulated terminals mounted on a 1/8-in. thick metal plate, which is an integral part of the tube. The end plate, which contains an "O" ring to insure vacuum integrity, is held to the tube by the three screws. After assembly, the telemeter is turned on by the insertion of a short rod into a 3/8-in. diameter hole in the side of the sleeve that activates the auxiliary power supply. The projectile is now ready to be fired.

Figure 13 presents an exploded view of the telemetry projectile, showing its aluminum sleeve, the antenna/transmitter module, load-simulator/SCO modules, auxiliary power supply, the test battery in its holder, and the end cap. Figure 14 is a photograph of the assembled projectile.

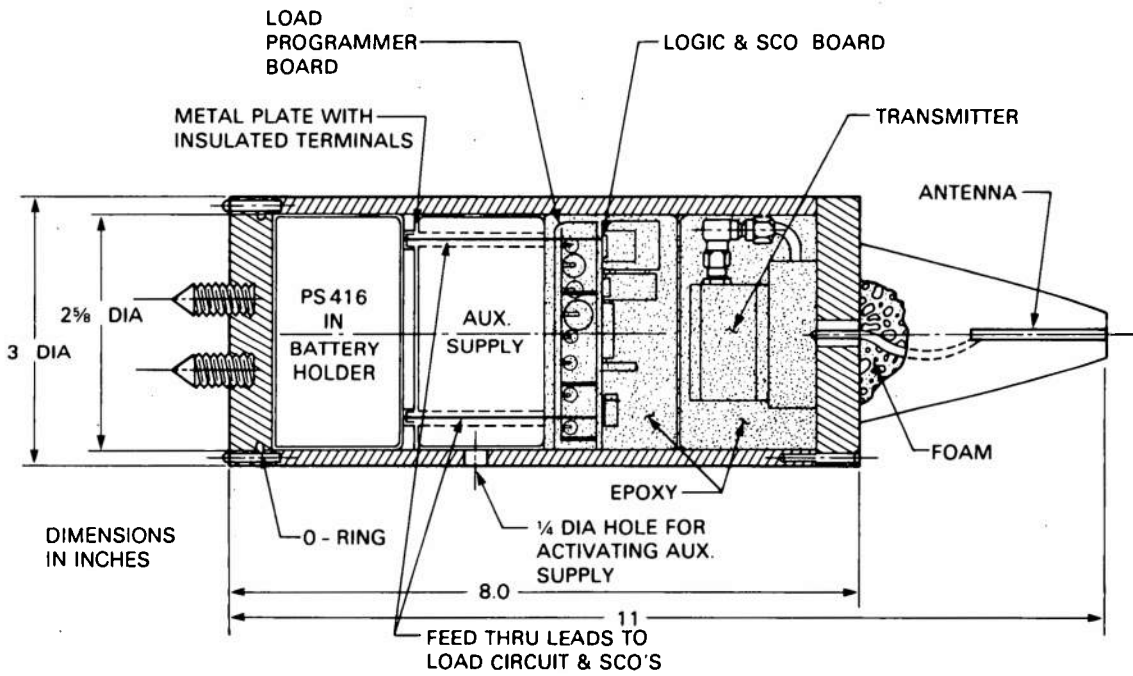

Figure 12. Three-in. spin air-gun telemetry projectile.

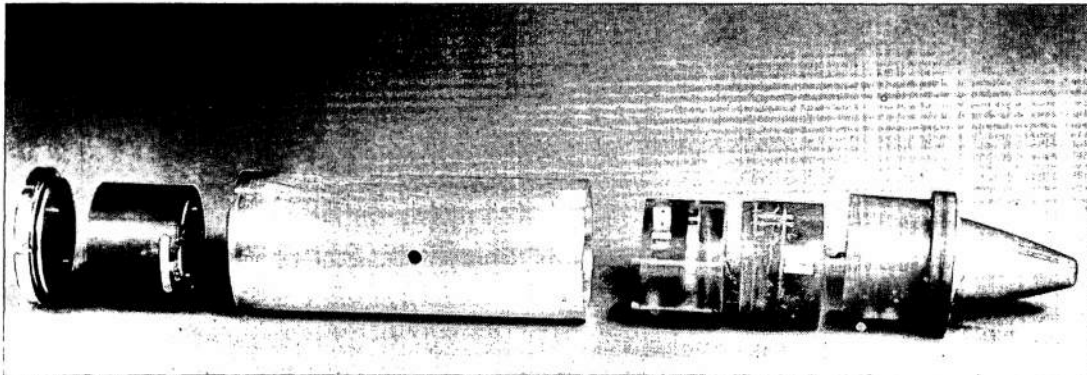

Figure 13. Exploded view of telemeter.



Figure 14. Telemeter projectile.

The receiving equipment, shown in figure 15 (p 17), is remotely located. A dipole receiving antenna is placed a few inches from the entrance to the spin tube. The telemetry signal picked up by the antenna is fed to the receiver over coaxial cable. The composite signal is then demodulated, and shifts in frequency, which are directly proportional to battery voltage, are recorded.

#### 4. SYSTEM PERFORMANCE

The telemeter projectile was successfully tested in the 3-in. spin air gun. Six PS416 battery power supplies were tested at peak accelerations of 7 g and spins of 190 rps. Recordings of the battery voltage and current pulses were made on a two-channel x-y recorder (fig. 16).

One minor drawback of the system is that the frequency responses of the 22-kHz SCO and the x-y recorder are insufficient to capture the peak current pulses. The use of a higher frequency SCO (124 kHz) and an oscillographic-type recorder would solve this problem. Nevertheless, reading the battery voltage from the voltage trace and knowing the value of the load resistors allows the actual pulse currents to be calculated even with the 22-kHz SCO. The most significant observation of the current trace is that the battery was appropriately loaded at the prescribed times.

DIPOLE ANTENNA NEAR  
ENTRANCE TO SPIN TUBE

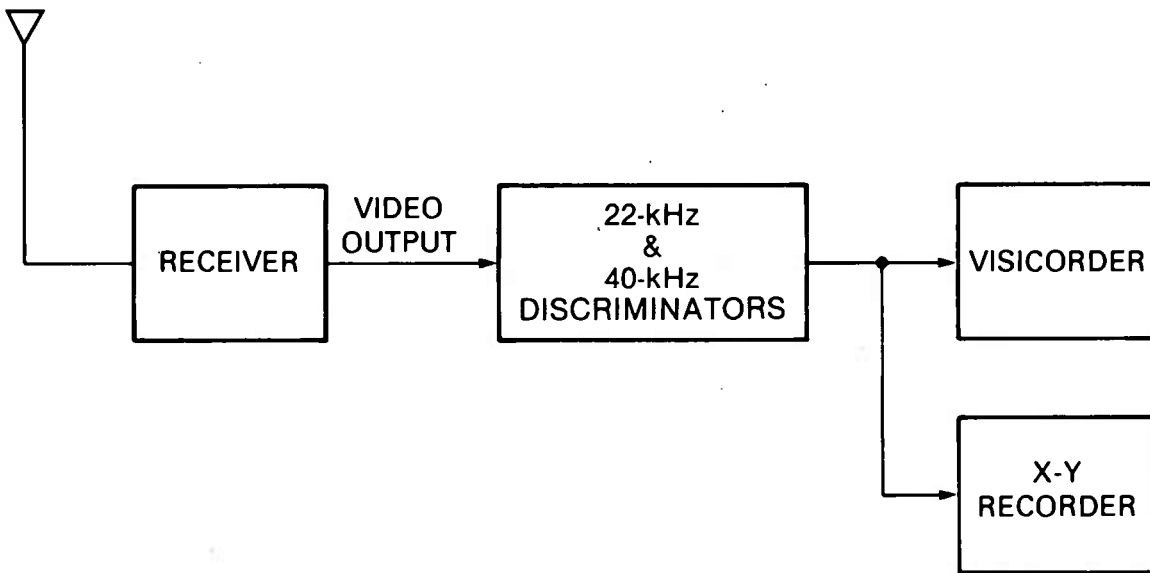

Figure 15. Block diagram of receiving equipment.

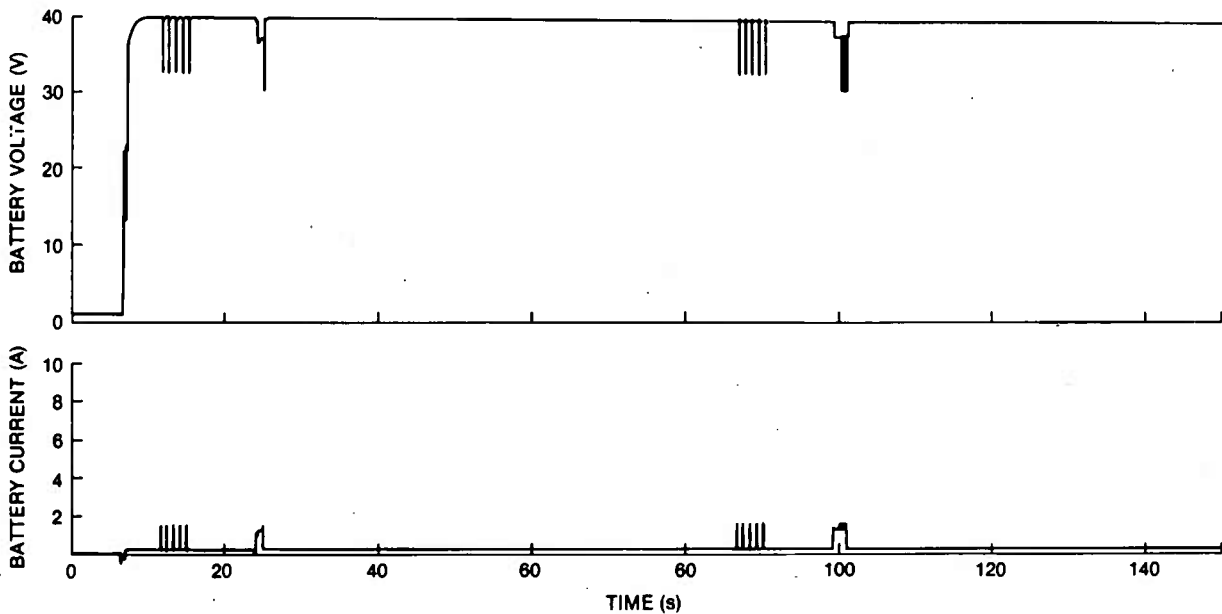

Figure 16. Spin air-gun load sequence for PS416 battery power supply.

## 5. SUMMARY

The two-channel telemetry projectile described in this report is an invaluable tool for evaluating fuze power supplies under simulated artillery environments. Telemetry read-out permits a degree of precision and reliability unattainable with the read-out of electrical data through sliding contacts. This design completes a test facility that has the following benefits:

a. It permits more acceptance testing of battery power supplies at lower costs. The costs associated with field tests (gun crews, instrumentation vans and personnel, projectiles, etc) become prohibitive in large-volume test programs.

b. It provides quick turn-around time between incorporation of new design features and availability of results.

c. It reduces data losses, particularly post-mortem data associated with unrecovered rounds in field tests.

The two-channel telemeter not only provides the best solution to the monitoring problem in the spin air gun, but also forms a basic system where additional data channels can be added as needed with a minimum of changes. The potential usefulness for this telemetry system extends to other applications which may require remote voltage monitoring for varying periods of time.

## 6. RECOMMENDED IMPLEMENTATION

The two-channel telemetry read-out system, when used with the 3-in. spin air gun, will permit more acceptance testing of battery power supplies for the M735 and XM749 fuzes. Batteries can be activated in the factory at far lower cost than during field testing. The facility has the added advantage of providing quick test results for proposed changes in battery design. The results of this effort will be implemented by the engineering division of the Harry Diamond Laboratories in the discharge of their responsibility for establishing manufacturing facilities and for production support.

#### ACKNOWLEDGEMENTS

The author gratefully acknowledges the technical assistance of Fabian Liss throughout the design phase of the project, and the guidance of Howard Jones in the use of his parallel-plate wedge antenna designs.

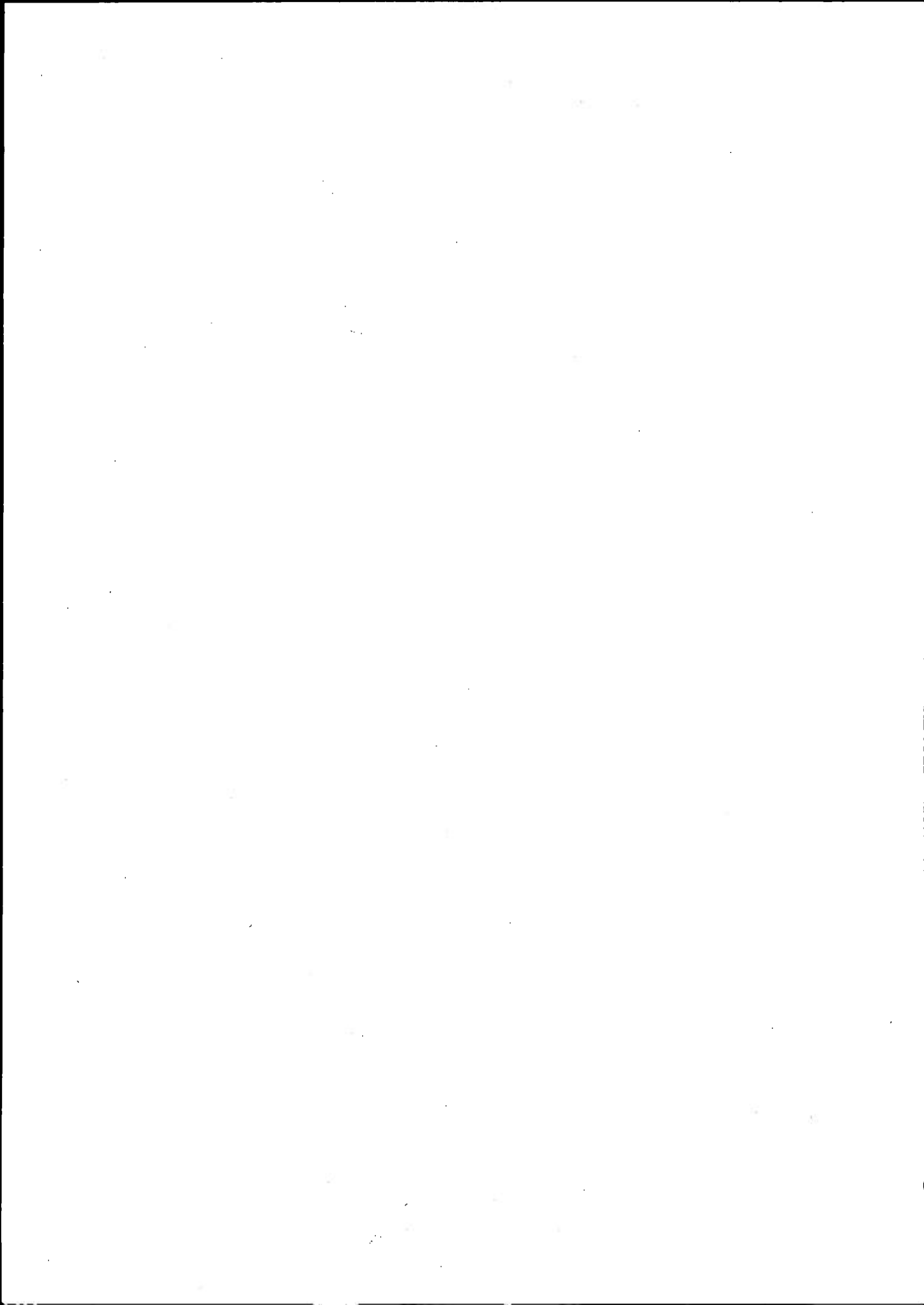

DISTRIBUTION

ADMINISTRATOR  
DEFENSE TECHNICAL INFORMATION CENTER  
CAMERON STATION, BUILDING 5  
ATTN DTIC-DDA (12 COPIES)  
ALEXANDRIA, VA 22314

COMMANDER  
US ARMY RSCH & STD GP (EUR)  
ATTN CHIEF, PHYSICS & MATH BRANCH  
FPO NEW YORK 09510

COMMANDER  
US ARMY ARMAMENT MATERIEL  
READINESS COMMAND  
ATTN DRGAR-LEP-L, TECHNICAL LIBRARY  
ATTN DRGAR-ASF, FUZE AND MUNITIONS  
SUPPORT DIV  
ROCK ISLAND, IL 61299

COMMANDER  
US ARMY MISSILE & MUNITIONS  
CENTER & SCHOOL  
ATTN ATSK-CTD-F  
REDSTONE ARSENAL, AL 35809

DIRECTOR  
US ARMY MATERIEL SYSTEMS ANALYSIS  
ACTIVITY  
ATTN DRXSY-MP  
ABERDEEN PROVING GROUND, MD 21005

DIRECTOR  
US ARMY BALLISTIC RESEARCH LABORATORY  
ATTN DRDAR-TSB-S (STINFO)  
ABERDEEN PROVING GROUND, MD 21005

US ARMY ELECTRONICS TECHNOLOGY  
AND DEVICES LABORATORY  
ATTN DELET-DD  
FORT MONMOUTH, NJ 07703

HQ USAF/SAMI  
WASHINGTON, DC 20330

TELEDYNE BROWN ENGINEERING  
CUMMINGS RESEARCH PARK  
ATTN DR. MELVIN L. PRICE, MS-44  
HUNTSVILLE, AL 35807

ENGINEERING SOCIETIES LIBRARY  
345 EAST 47TH STREET  
ATTN ACQUISITIONS DEPARTMENT  
NEW YORK, NY 10017

COMMANDER  
US ARMY ARMAMENT RESEARCH AND  
DEVELOPMENT COMMAND  
ATTN DRCPM-SA, PM, SELECTED AMMUNITION  
ATTN DRDAR-LC, LARGE CALIBER WEAPON  
SYSTEMS LABORATORY  
DOVER, NJ 07801

COMMANDER  
WATERVLIET ARSENAL  
WATERVLIET, NY 12189

COMMANDER  
US ARMY ABERDEEN PROVING GROUND  
ATTN STEAP-TL, TECH LIB  
ABERDEEN PROVING GROUND, MD 21005

COMMANDER  
US ARMY ELECTRONICS PROVING GROUND  
FORT HUACHUCA, AZ 85613

COMMANDANT  
US ARMY FIELD ARTILLERY SCHOOL  
ATTN LIBRARY  
FORT SILL, OK 73503

COMMANDER  
NAVAL SURFACE WEAPONS CENTER  
ATTN E-40, TECHNICAL LIB  
WHITE OAK, MD 20910

COMMANDER  
US AIR FORCE SYSTEMS COMMAND  
ANDREWS AFB  
ATTN TECHNICAL LIBRARY  
WASHINGTON, DC 20334

SANDIA LABORATORIES  
LIVERMORE LABORATORY  
P.O. BOX 969  
LIVERMORE, CA 94550

SANDIA NATIONAL LABORATORIES  
P.O. BOX 5800  
ALBUQUERQUE, NM 87185

US ARMY ELECTRONICS RESEARCH  
& DEVELOPMENT COMMAND  
ATTN TECHNICAL DIRECTOR, DRDEL-CT  
ATTN LEGAL OFFICE  
ATTN R. MOORE, DRDEL-PA (3 COPIES)

DISTRIBUTION (Cont'd)

HARRY DIAMOND LABORATORIES  
ATTN CO/TD/TSO/DIVISION DIRECTORS  
ATTN RECORD COPY, 81200  
ATTN HDL LIBRARY, 81100 (3 COPIES)  
ATTN HDL LIBRARY, 81100 (WOODBRIDGE)  
ATTN TECHNICAL REPORTS BRANCH, 81300  
ATTN CHAIRMAN, EDITORIAL COMMITTEE  
ATTN CHIEF, 34400  
ATTN CHIEF, 34000  
ATTN J. BEARD, 34200  
ATTN I. MARCUS, 42800 (2 COPIES)  
ATTN R. W. TUCKER, 13300  
ATTN H. A. BRANN, 47400  
ATTN C. LANHAM, 00213  
ATTN T. LISS, 15400  
ATTN F. ALLEN, 34400 (5 COPIES)

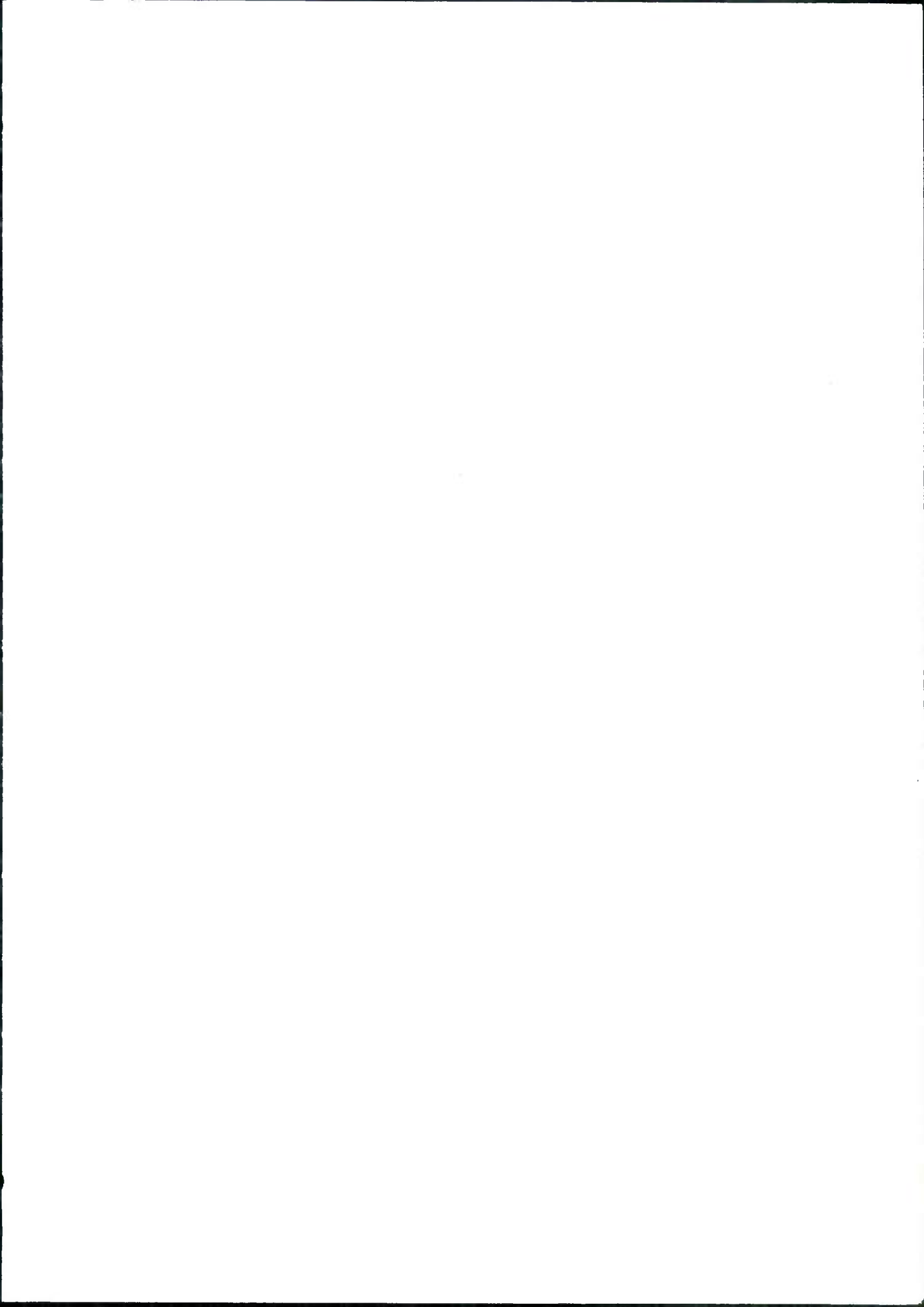

DETACHMENT OF THE ARMY  
An Equal Opportunity Employer

Harry Diamond Laboratories  
2800 Powder Mill Rd  
Adelphi, MD 20783

U.S. OFFICIAL MAIL  
PENALTY  
FOR  
PRIVATE  
USE \$400  
F. M. T. T. P.  
SEP 1972  
RIVERDALE  
AUG-5 '81  
MD.  
U.S. POSTAGE  
52

COMMANDER  
US ARMY ARMAMENT MATERIEL  
READINESS COMMAND  
ATTN DR SAR-LEP-L, TECHNICAL LIBRARY  
ROCK ISLAND, IL 61299