

AD A102812

FILE COPY

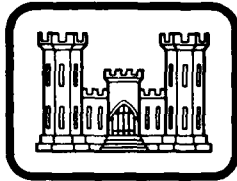

LEVEL

Pa



MISCELLANEOUS PAPER SL-81-15

AN EXPEDIENT METHOD FOR EXCAVATION OF FOXHOLES

by

George A. Woodbury, Allen D. Rooke, Jr.

Structures Laboratory
U. S. Army Engineer Waterways Experiment Station
P. O. Box 631, Vicksburg, Miss. 39180

June 1981

Final Report

Approved For Public Release; Distribution Unlimited

DTIC
ELECTE
AUG 14 1981



Prepared for Office, Chief of Engineers, U. S. Army
Washington, D. C. 20314

Under MEACE Project No. 4A762719AT40

81 8 13 085

**Destroy this report when no longer needed. Do not return
it to the originator.**

**The findings in this report are not to be construed as an official
Department of the Army position unless so designated
by other authorized documents.**

**The contents of this report are not to be used for
advertising, publication, or promotional purposes.
Citation of trade names does not constitute an
official endorsement or approval of the use of
such commercial products.**

Unclassified

SECURITY CLASSIFICATION OF THIS PAGE (When Data Entered)

REPORT DOCUMENTATION PAGE		READ INSTRUCTIONS BEFORE COMPLETING FORM
1. REPORT NUMBER Miscellaneous Paper SL-81-15	2. GOVT ACCESSION NO. AD-A102 812	3. RECIPIENT'S CATALOG NUMBER
4. TITLE (and Subtitle) AN EXPEDIENT METHOD FOR EXCAVATION OF FOXHOLES	5. TYPE OF REPORT & PERIOD COVERED Final report	
7. AUTHOR(s) George A. Woodbury Allen D. Rooke, Jr	6. PERFORMING ORG. REPORT NUMBER	
9. PERFORMING ORGANIZATION NAME AND ADDRESS U. S. Army Engineer Waterways Experiment Station Structures Laboratory P. O. Box 631, Vicksburg, Miss. 39180	8. CONTRACT OR GRANT NUMBER(s)	
11. CONTROLLING OFFICE NAME AND ADDRESS Office, Chief of Engineers, U. S. Army Washington, D. C. 20314	10. PROGRAM ELEMENT, PROJECT, TASK AREA & WORK UNIT NUMBERS MEACE Project No. 4A762719AT40	
14. MONITORING AGENCY NAME & ADDRESS (if different from Controlling Office) 15T	12. REPORT DATE June 1981	
	13. NUMBER OF PAGES 45	
	15. SECURITY CLASS. (of this report) Unclassified	
	15a. DECLASSIFICATION/DOWNGRADING SCHEDULE	
16. DISTRIBUTION STATEMENT (of this Report) Approved for public release; distribution unlimited.		
17. DISTRIBUTION STATEMENT (of the abstract entered in Block 20, if different from Report)		
18. SUPPLEMENTARY NOTES Available from National Technical Information Service, 5285 Port Royal Road, Springfield, Va. 22151.		
19. KEY WORDS (Continue on reverse side if necessary and identify by block number) Detonation Military operations Expedient construction Explosive excavation Hand augers		
20. ABSTRACT (Continue on reverse side if necessary and identify by block number) A technique involving standard demolitions and a modified entrenching tool is examined as an expedient means of rapidly constructing a foxhole. The basic design was developed in sandy, clayey silt, with limited tests in other materials. It consists of simultaneous detonation of two small charges, total energy yield being 1.5-lb TNT, one charge above the other. Except in rocky soils, which prevent augering and emplacement of the lower charge, the result		

(Continued)

Unclassified

SECURITY CLASSIFICATION OF THIS PAGE(When Data Entered)

20. ABSTRACT (Continued).

is a hole suitable for immediate cover and for improvement to meet standard fox-hole criteria.

Background and requirements are discussed, along with advantages and disadvantages of this method of construction. It is recommended that this technique be adopted as an expedient, and that additional research and hardware development be conducted as necessary to standardize it.

Unclassified

SECURITY CLASSIFICATION OF THIS PAGE(When Data Entered)

PREFACE

This study was conducted during FY 1977 under the sponsorship of the Office, Chief of Engineers, U. S. Army, as a part of the Military Engineering Applications of Commercial Explosives (MEACE) program under Project 4A762719AT40, "Mobility, Soils, and Weapons Effects Technology." It did not apply to any specific work unit and as such was not intended as a complete study leading to a problem solution. Rather, this test series was intended to determine if the concepts as presented herein had any merit which warranted further consideration.

Assisting in the field work were Messrs. Sherman B. Price, John E. Shaler, and Melvin Miller. This report was prepared by MAJ George A. Woodbury, Project Engineer, and by Mr. A. D. Rooke, Jr., Explosion Effects Division (EED), Structures Laboratory. Assisting in the preparation of this report was Ms. Elizabeth Klein. Special appreciation is expressed to Mr. H. D. Carleton, who, as MEACE Project Officer, advised and encouraged this study. Mr. L. F. Ingram, Chief of the EED, provided general supervision. Mr. W. J. Flathau was the Chief of the Weapons Effects Laboratory (WEL) which conducted this investigation. A reorganization which occurred during the conduct of the study resulted in WEL being absorbed into a newly created Structures Laboratory, headed by Mr. Bryant Mather.

Commanders and Directors of WES during the conduct of this study and preparation of this report were COL John L. Cannon, CE and COL Nelson P. Conover, CE. Mr. F. R. Brown was the Technical Director.

Accession For	<input checked="" type="checkbox"/>
NTIS GRA&I	<input type="checkbox"/>
DTIC TAB	<input type="checkbox"/>
Unannounced	<input type="checkbox"/>
Justification	
By	
Distribution/	
Availability Codes	
Avail and/or	
Special	

A

CONTENTS

	<u>Page</u>
PREFACE	1
CONVERSION FACTORS, INCH-POUND TO METRIC (SI)	
UNITS OF MEASUREMENT	3
PART I: INTRODUCTION	4
Background	4
Preliminary Considerations	5
Objectives	5
PART II: DESCRIPTION OF STUDY	7
Charge Design	7
Auger Design Concept	7
Test Conditions	11
PART III: TEST RESULTS	22
Auger Performance	22
Explosive Design Performance	22
PART IV: DISCUSSION, CONCLUSIONS, AND RECOMMENDATIONS	23
Discussion	23
Conclusion	23
Recommendations	24
REFERENCES	26
TABLES 1 and 2	
APPENDIX A: STANDARDS FOR FOXHOLE CONSTRUCTION	A1
APPENDIX B: 1977 CONFERENCE ON EXPLOSIVE FOXHOLE EXCAVATION	B1

CONVERSION FACTORS, INCH-POUND TO METRIC (SI)
UNITS OF MEASUREMENT

Inch-pound units of measurement used in this report can be converted to metric (SI) units as follows:

<u>Multiply</u>	<u>By</u>	<u>To Obtain</u>
feet	0.3048	metres
feet per pound (mass)*	0.6720	metres per kilogram
grains	0.00006480	kilograms
inches	2.54	centimetres
pounds (mass)	0.4536	kilograms
pounds per cubic foot	16.02	kilograms per cubic metre

* Assuming equivalence between weight and mass, e.g. $1\text{ lb}_{\text{force}} = 1\text{ lb}_{\text{mass}}$.

AN EXPEDIENT METHOD FOR EXCAVATION OF FOXHOLES

PART I: INTRODUCTION

Background

1. U. S. forces employed in mobile combat operations need a rapid method to prepare dug-in positions for individual and crew-served weapon protection. Presently, the individual soldier must rely on hand tools to accomplish this.

2. During the early 1970's, an explosive "foxhole"* digging aid was procured and field tested. This device relied on a small shaped charge to prepare an emplacement hole for a small cratering charge. The cratering charge loosened the soil, reducing the effort required to excavate it with hand tools. This device is no longer in production because of unacceptable reliability and other problems, such as acoustic and visual signatures. In October 1977, a meeting was held at Fort Belvoir, Virginia, to review previous work and to redefine requirements. As an invitee, the U. S. Army Engineer Waterways Experiment Station (WES) was provided an opportunity to present an alternative approach to the problem (Appendix B, meeting announcement and minutes).

3. Preliminary investigation into the meeting's stated purpose clearly indicated the potential for a new research effort, which could significantly delay introduction of an acceptable item into the field. It was also apparent that this effort would be directed at a two-shot kit having a shaped charge and a cratering charge. During the short time available between notification and the meeting, it was decided to undertake an effort to see if the task might be accomplished using existing equipment and demolitions, with the hope that the outcome could serve as a "quick fix," or might simply be included in appropriate

* Widely accepted name for an individual dug-in field fortification. Appendix A shows idealized dimensions of individual and crew-served weapons positions.

literature (school texts and field manuals) as an expedient solution to rapid construction of foxholes.

Preliminary Considerations

4. Shaped-charge designs have not achieved clean boreholes with an acceptable degree of reliability.* An alternative to the shaped charge is hand-augering of a pilot borehole for charge emplacement. The charge size can be chosen to suit soil conditions and the size of emplacement desired. The disadvantages of hand-augering are that it takes more time and effort and may be impossible in extremely rocky or frozen soils; however, the shaped charge also performs poorly in rocky or frozen soils.

5. Weight and bulk are additional considerations. Infantry and airborne soldiers, who are most in need of a rapid entrenching device, are penalized by additional tools or equipment that must be carried.

6. Finally, the capability to prepare a position with maximum safety and minimum notification to the enemy is an important consideration. The loud noise from above-ground explosions limits the usefulness of a shaped charge for this purpose. The shaped charge also creates a missile hazard during detonation.

Objectives

7. Test objectives were:

- a. To explosively construct an individual dug-in position that would provide immediate protection to the individual soldier, and which could be improved with time to approach the dimensions of the field-manual foxhole. Initial desired hole dimensions were 4 ft** in surface diameter and 3.5-ft depth.
- b. To restrict total weight of explosive and additional equipment to 4 lb.

* A problem currently under study at WES under a separate work unit.

** A table of factors for converting inch-pound units of measurement to metric (SI) units is presented on page 3.

- c. To permit adaptability such that charge size could be varied to suit soil conditions.
- d. To maximize safety and reliability while minimizing signature.

PART II: DESCRIPTION OF STUDY

Charge Design

8. If total kit weight were to be restricted to 4 lb, and if the auger (discussed below) were to weigh about 1 lb, it was necessary that the total explosive weigh no more than 3 lb. It has been observed that a charge buried at near-optimum depth will excavate a crater whose diameter is approximately twice its depth. Further, cratering capability curves (Figures 1 and 2) show that, for the soil conditions at the test site, a charge on the order of 1-lb TNT or less could be expected to create a crater with the desired 4-ft diameter when detonated at a depth of about 1.5 to 2.0 ft. To obtain the additional depth needed for the foxhole, it would be necessary to add one or more charges below the first charge. Obviously, the simplest workable design was the most desirable; hence, the two-charge concept came into being. The second charge would necessarily be near containment depth, usually taken as $\sim 3.5 \text{ ft/lb}^{1/3}$. Figure 3 illustrates this concept. While some advantage might be realized by placing a delay between the two charges, this was eliminated from consideration as an unnecessary complication, and also because delay caps are not common to military demolitions. Thus, the simple concept of a simultaneous two-charge geometry formed the basis for the testing of various combinations of charge weights and depths to establish an optimum design.

Auger Design Concept

9. In order to avoid the necessity for a new piece of equipment, it seemed desirable to adapt an auger to the soldier's entrenching tool. This approach minimizes weight, bulk, and development time. The length of the auger is determined by two factors: (1) charge depth of burial (DOB) requirements, and (2) the design of the entrenching tool. The folded length of the entrenching tool is approximately 9 in., therefore, the best length for the auger sections would also be 9 in. The handle of the tool without the spade attached has a usable length for borehole

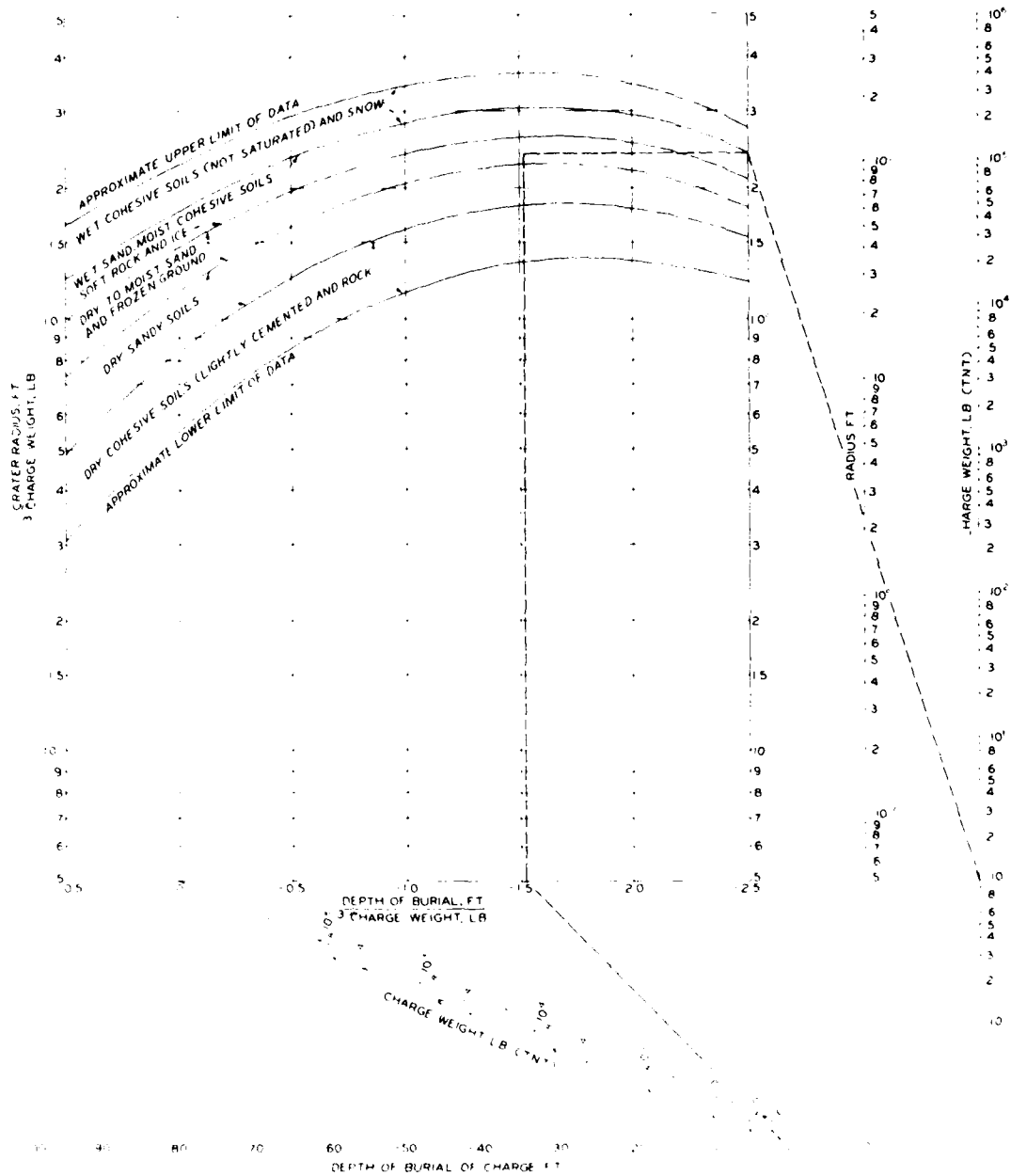

Figure 1. Nomograph for crater radius adapted from Stange (1961). Dashed lines illustrate use for a small charge typical to this study; entry may be from either bottom or right-hand scale, depending upon information sought

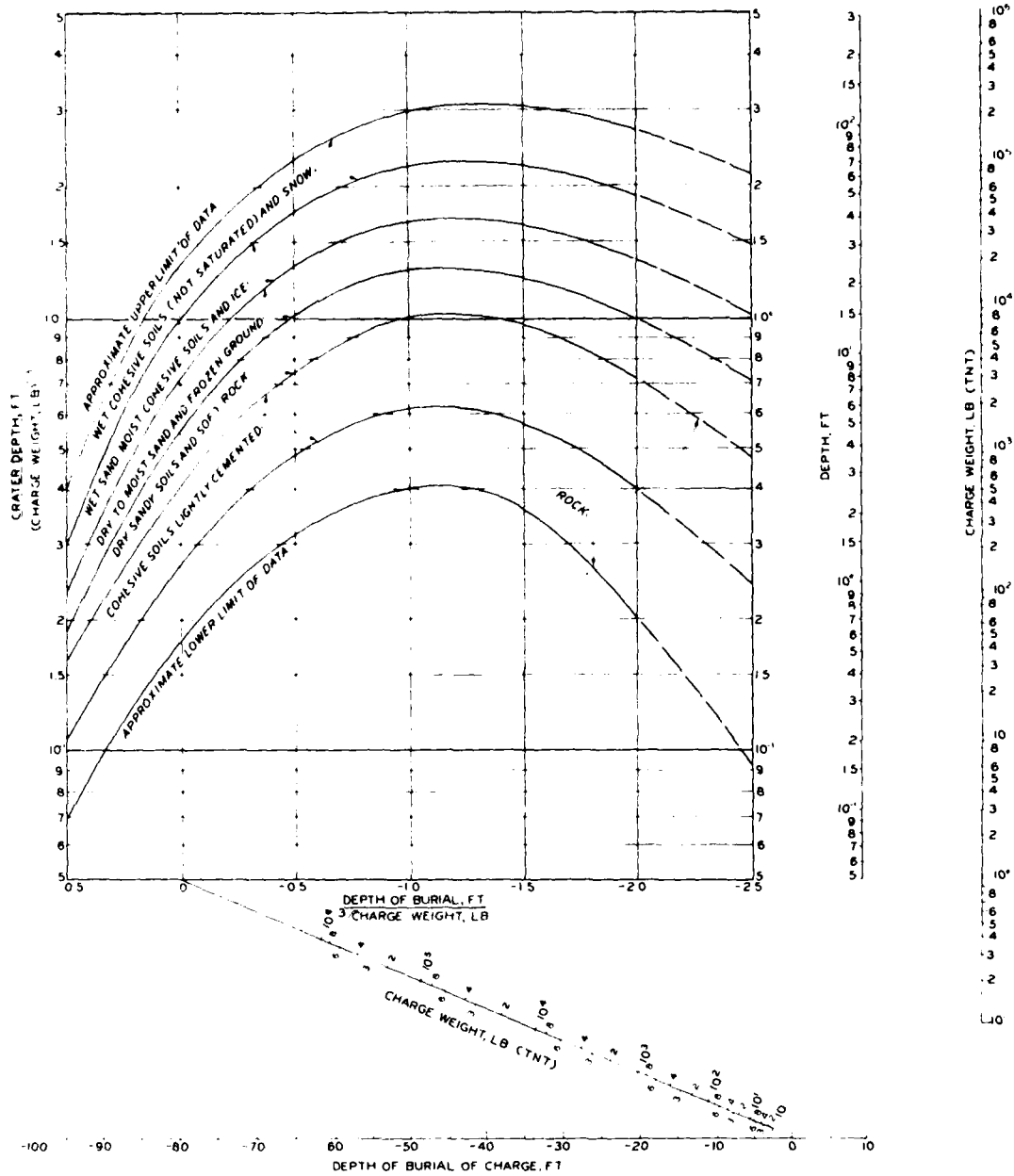
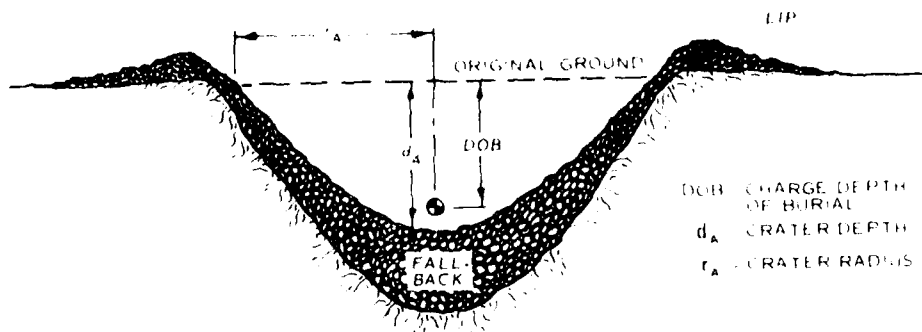
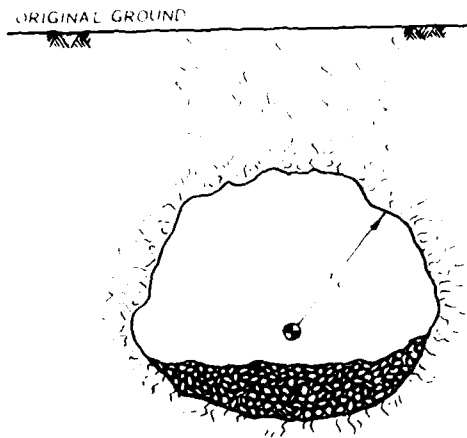

Figure 2. Nomograph for crater depth adapted from Strange (1961).
See Figure 1 for example of use



a. "NORMAL" CHARGE BURIAL AND RESULTING CRATER



b. CAMOUFLET RESULTING FROM CONTAINED CHARGE

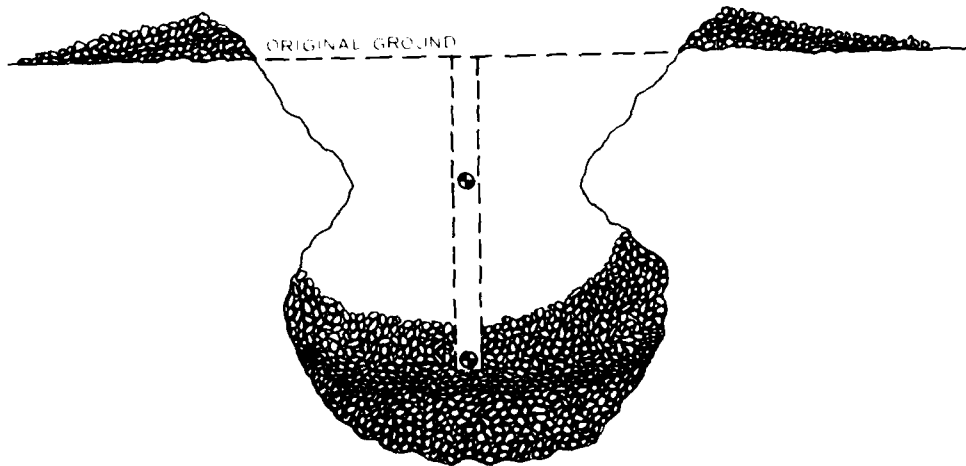

c. TWO-CHARGE CRATER

Figure 3. Concept of two-charge foxhole

augering of 9 in. Thus, the required auger adaption length became charge borehole requirement, less 9 in.

10. As a result of the tests (discussed later), the total length of the auger was determined to be 36 in.; this meant an adapter length of 26.9 in., rounded to 27 in. This conveniently breaks down into three 9-in. sections. The center section needs to be universal to allow additional sections to be added from other kits for special applications requiring deeper emplacement holes.

11. A 2-1/4-in. auger diameter was selected because a borehole of this size would accept any of the standard small military explosives, including dynamite, TNT, C-4, and the hand grenade. The lead portion of the auger was reduced in diameter to improve the auger's performance in gravelly soils. The components of the test auger were all standard commercial items. The auger bit was made from a Sears 2-1/4-in. wood bit. The pipe was 1/2-in.-ID and 1/2-in.-OD steel welded together to make the female end. The total weight of the extension was 2.39 lb. This could be reduced significantly by using the same alloy the entrenching tool is made from and by reducing the thickness of the bit, which, in its present form, is stronger than necessary.

12. It is envisioned that the original nylon carrying case (current issue is a plastic case) could be modified by sewing a pouch to the outside face into which the three extensions could be inserted. Photographs of the entrenching tool and auger adapter are contained in Figure 4.

Test Conditions

13. The main portion of the test program was divided into two phases. Phase 1 evaluated the cratering performance of small charges up to 0.75 lb TNT, while Phase 2 evaluated the two-charge concept discussed above. These tests were conducted at the WES Big Black Test Site (BBTS) (Figure 5). In general, the soil at this site is characterized as a sandy, clayey silt (CL-ML) in the Unified Soil Classification System. Borings reveal a thick layer of silt, interspersed with sand and some

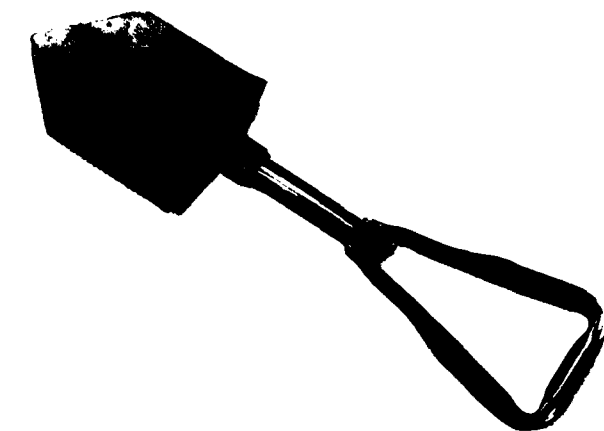

a. Tool ready for use

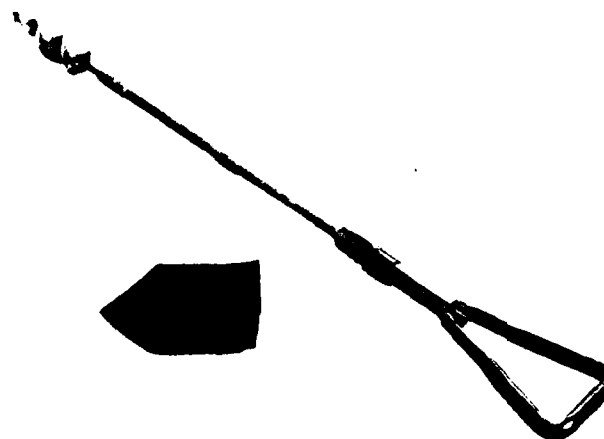

b. Tool with auger substituted for shovel



c. Folded entrenching tool and disassembled auger

Figure 4. Entrenching tool and auger adaptation

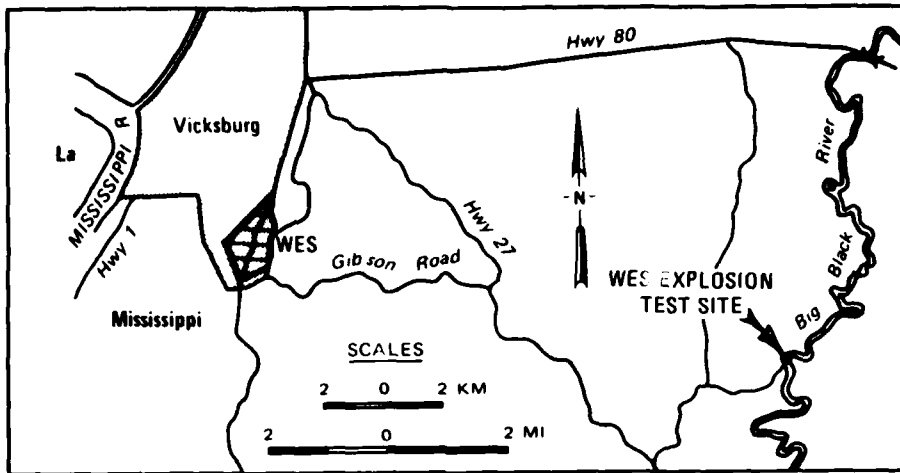

a. Vicinity map of WES Big Black Test Site



b. Aerial view of WES Test Site on Big Black River

Figure 5. WES Big Black Test Site

clay down to a depth of about 40 ft, where it is underlain by gravel and marl. The water table varies both seasonally and with proximity to the Big Black River, occurring at depths of roughly 20-30 ft. If the top 20 ft are considered to be divided into three zones, the following tabulation can be made of soil properties (Carleton, Sullivan, and Rooke in preparation).

Depth ft	Approximate Wet Density* lb/ft ³	Approximate Range of Water Content** Percent	Atterberg Limits	
			Plastic	Liquid
0-3.0	100	10-28	28	32
3.0-9.8	112	25-30	23	36
9.8-19.7	119	27-30	25	32

* Varies with water content.

** During times of normal test operations; excluding extreme conditions.

Soil moisture was not measured during the conduct of these tests, but was estimated at 18-22 percent at the surface.

Phase 1

14. All tests were accomplished with standard 1/4-lb blocks of TNT (Figure 6) primed with 50-grain (50 grains per foot) detonating cord, and were intended to verify previous results (Strange 1961) for the particular locations and soil moisture conditions existing at the time of these tests. Charge emplacement holes were hand-augered using a 2-1/4-in.-diam auger having similar characteristics to the auger pictured in Figure 4. Charge DOB was measured to the center of the charge. All charges were stemmed (backfilled and tamped). The resulting craters were measured for depth and diameter using the original, undisturbed ground surface as a reference. Figure 7 illustrates hand augering procedure and shows a typical foxhole crater.

Phase 2

15. For the two-charge array of Phase 2, a near-camouflet depth was sought for the lower charge, thereby creating a chamber whose true bottom (below the fallback) would be approximately 4.0 ft deep. This

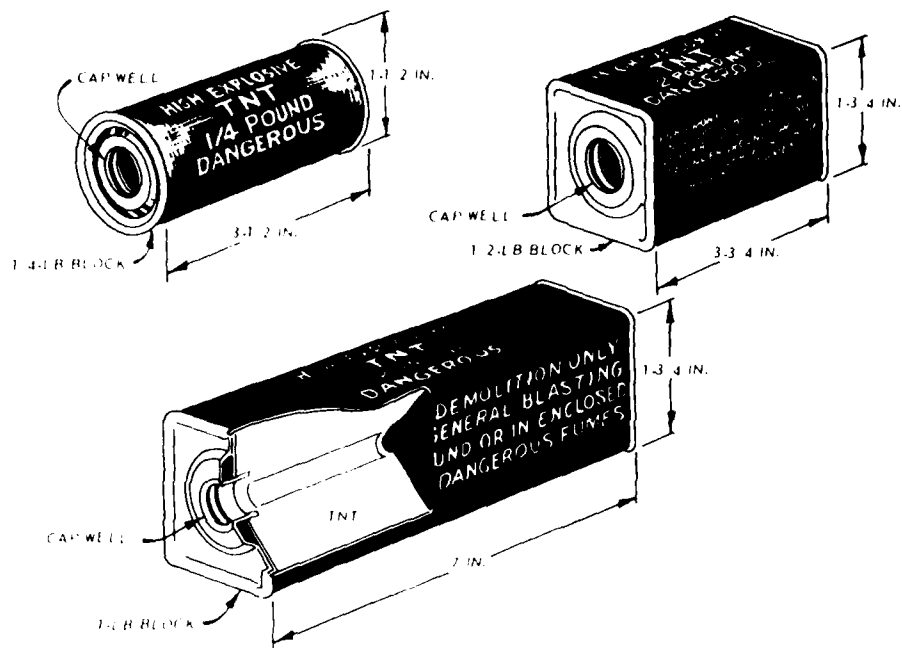

Figure 6. TNT block explosives used in tests
(U. S. Army Field Manual 5-25 1971)

depth was considered optimum for completion of the foxhole, to include construction of the grenade sump (Figure A1). For the BBTS, camouflet diameter D can be estimated by

$$D = (2.3 \pm 0.4)W^{1/3} \quad (1)$$

where

D = feet

W = charge weight in lb TNT (Strange 1961)

16. A nominal 3-ft borehole depth was selected as the best depth for testing variations of small charges. Note, for example, that a 1-lb charge (Figure 6) would have a charge center $36.0 - 3.5 = 32.5$ in. below ground surface. Adding from this point the expected radius of a camouflet,



a. Hand augering using converted entrenching tool



b. Typical foxhole crater resulting from Phase 1 single-charge tests

Figure 7. Hand-augering procedure and resulting typical foxhole crater

$$\frac{D}{2} = \frac{2.3(1.0)^{1/3}}{2}$$

(2)

$$= 1.15 \text{ ft}$$

and the expected true depth (bottom of loose soil) becomes 3.86 ft.

17. A deviation from the normal procedure occurred in Phase 2: boreholes were excavated using a 4-in. auger. This was done to permit side-by-side placement of the TNT charges where necessary, and thus to avoid possible cratering degradation due to elongated charges. In this way, charge length-to-diameter ratios were kept below 1.5. It is not felt that this deviation affects the results of recommendations.

18. Charges were individually boosted with 50-grain detonating cord. The backfill between and above the charges was tamped. The two lengths of detonating cord were brought to the surface, where initiation was effected by a No. 8 blasting cap.

Additional tests

19. There were limited opportunities to test the auger in soils other than the BBTS. Such tests were accomplished in conjunction with other projects. These locations, along with descriptions of near-surface soils, are given in the following paragraphs.

20. Harry S. Truman Reservoir, Warsaw, Missouri. The test site was in a bend of the Osage River (Figure 8). The soil was a mixture of sand, silt, and clay, with a high percentage of fine material and with a predominant classification of CL. It was underlain by limestone/dolomite bedrock at a depth of about 33 ft. The water table was estimated at depths between 11-14 ft. Moisture content ranged from 18 to 26 percent in the upper 10 ft, increasing below this depth. The liquid limit ranged from 20 to 39 percent, and the plastic limit from 13 to 17 percent, making the samples fall within the plastic range (Carleton, Sullivan, and Rooke in preparation).

21. Fort Leonard Wood, Missouri. The site (Figure 9) is characterized as native dolomite and sandstone overlain by 5-20 ft of

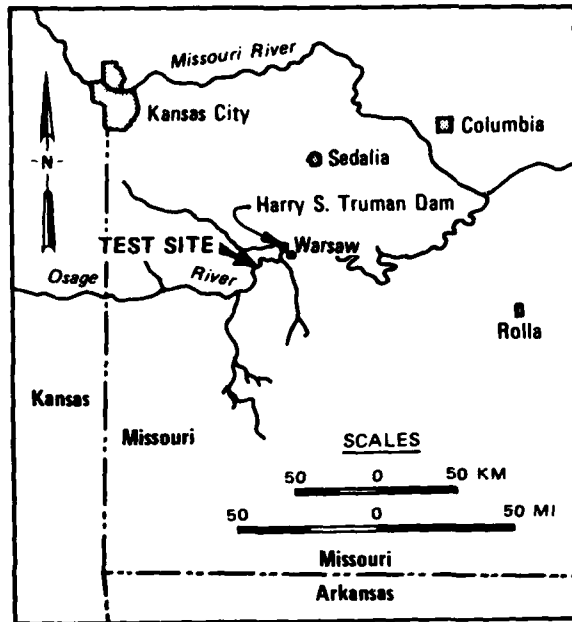

a. Vicinity map (Rand McNally 1978)



b. Site photograph

Figure 8. Harry S. Truman Reservoir test site

a. Vicinity map
(Rand McNally
1978)

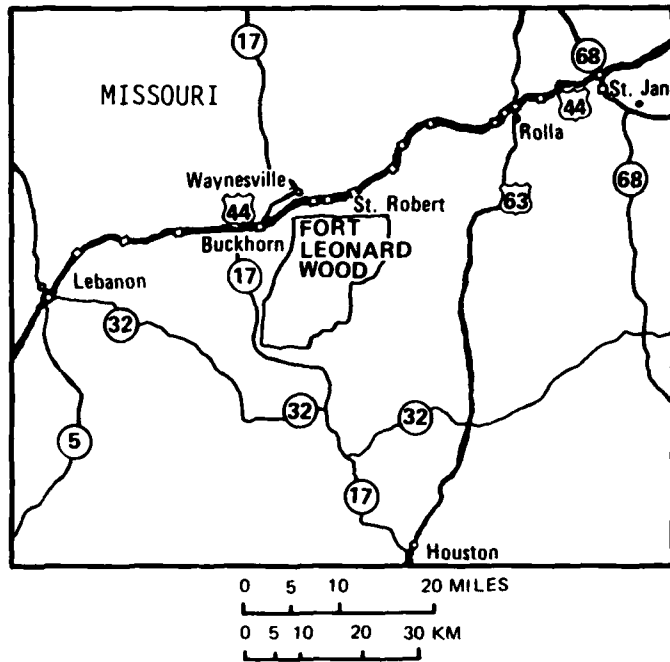

b. Closeup view of soil
at test site

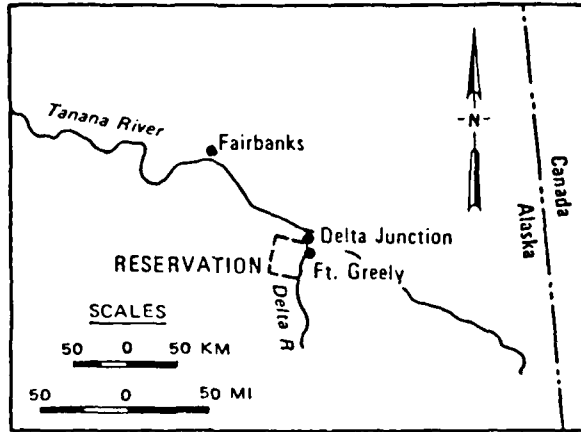

Figure 9. Vicinity map of Fort Leonard Wood and photograph
of surface soil texture

loess. Although classified as nonglacial, the surface geology is gravelly (mostly chert), as can be seen in Figure 9.

22. Fort Greely, Alaska. The Fort Greely site (Figure 10) consisted of a sandy silt (ML) with organic matter, average dry density about 76 lb/ft³. Moisture content averaged about 40 percent, representing a 92-percent degree of saturation. The soil is glacial in origin and is interspersed with rocks up to boulder size.

23. Yuma Proving Ground, Arizona. The site at Yuma Proving Ground (Figure 11) was typical southwestern U. S. desert, with "desert pavement" (igneous gravel) underlain by finer material. A stratum of calcareous material--possibly caliche--lay about 2 ft below the surface. The soil classification varied with depth, trending from sandy, silty gravel (GM) near the surface to sandy clay (CH) at a depth of 20 ft. Dry density at the surface was about 80 lb/ft³, becoming somewhat denser with depth. Moisture content was on the order of 3 percent.



a. Vicinity map (Rand McNally 1978)



b. Site photograph

Figure 10. Fort Greely test site

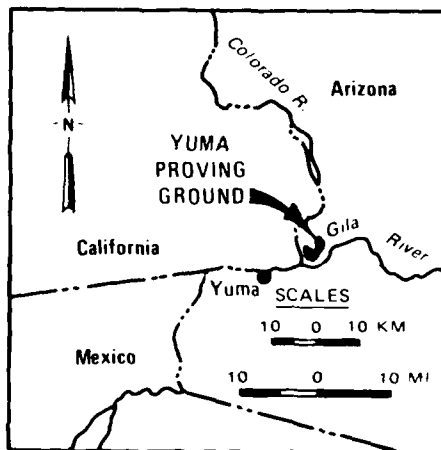

a. Vicinity map (Rand McNally 1978)

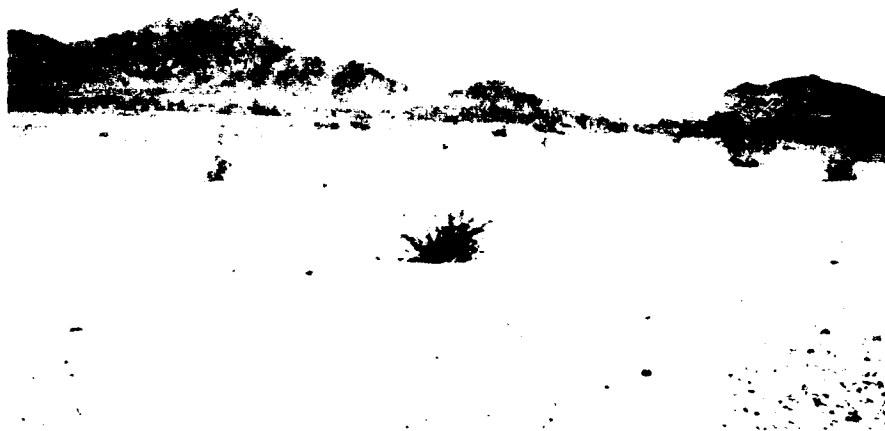

b. Site photograph

Figure 11. Test site at Yuma Proving Ground

PART III: TEST RESULTS

Auger Performance

24. As would be expected, the auger performed best in moist, fine-grained material such as that found at the BBTS and Harry S. Truman Reservoir. In these locations, the borehole could be completed in about 3 min. This could be increased to 15 min where moisture content was low - less than 10 percent - and the soil dense. At Yuma Proving Ground, the dry, granular soil would run off the auger and was difficult to remove from the borehole. Pouring water into the borehole during boring improved this situation. Some soft, friable rock resembling caliche was encountered, but penetration was achieved, with boreholes being completed in 20 to 30 min. The poorest performance was recorded in gravelly to rocky soils, such as those found at Fort Greely and Fort Leonard Wood. In the coarse gravel of Fort Greely, more than one attempt was usually necessary to achieve the desired depth, since the auger could not bypass the larger particles. When frozen (tests were conducted in both summer and winter), it was not possible to achieve depths greater than about 8 in. in this material. At Fort Leonard Wood, cobbles up to about 5 in. blocked attempts to complete boreholes.

Explosive Design Performance

25. The single charges performed as expected, with results (Table 1) falling within the ranges previously established by Strange (1961).

26. Table 2 contains results of the double charges. In reviewing these, several general observations may be made.

- a. Overall, the best results were obtained when the top charge was smaller than the bottom charge. The optimum ratio top: bottom appeared to be about 1:2.
- b. The best camouflet was obtained with a 1-lb lower charge, with $D \approx 2.6$ ft .
- c. The best results were obtained on Shot 7T5, where the upper 0.5-lb charge was buried at a scaled depth of $2.13 \text{ ft/lb}^{1/3}$.

PART IV: DISCUSSION, CONCLUSIONS, AND RECOMMENDATIONS

Discussion

Charge placement

27. The auger adaption performs well in many "ordinary" soils, but may be unsuitable in soils with a high gravel content, especially when such soils are frozen. Whether it offers any improvement in performance over the shaped charge concept could be resolved by a time-and-effort study involving the construction of foxholes by these methods. It does, however, offer an explosive method of foxhole construction with a relative low signature (noise and flash); this, too, could be quantified in side-by-side experiments. It also has some flexibility not available in the shaped-charge method in that the augered hole depth can be adjusted to suit the charge and soil conditions.

28. If the method developed in this study is adopted, further work is needed.

- a. Charge size/placement combinations should be more carefully examined in a variety of soils.
- b. The auger design should be examined with an eye toward reducing its weight (perhaps by using a lighter metal alloy) and strengthening its connections. Consideration should be given to an adapter that would allow it to be power driven when a power source might be available.

Explosive design

29. While purposely excluded from this test, the idea of a delay between charges has merit. Presumably, the upper charge should fire a few milliseconds before the lower charge for best results. For placement in the hands of nonengineer troops, a precut detonating cord with built-in delay would probably be best.

Conclusion

30. The expedient method researched in this study offers promise for rapid foxhole construction with reduced signature, within a limited

range of conditions. It is deserving of conditional adoption for additional study.

Recommendations

31. It is recommended that the foxhole construction method of this study be published in appropriate literature (e.g., Field Manuals 5-15, 5-34) as an expedient technique, perhaps illustrated as in Figure 12. It would require fabrication of an auger at unit level.

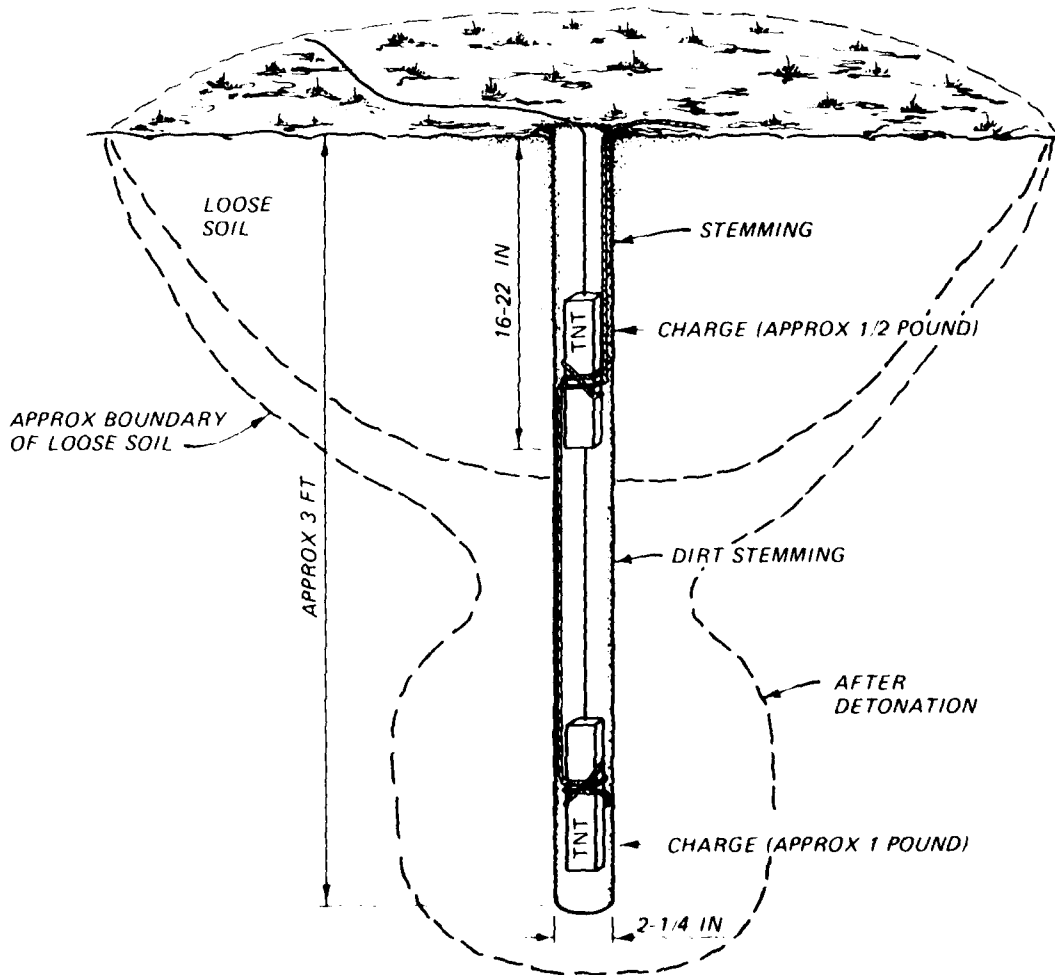

Figure 12. Illustration of two-charge foxhole

32. It is further recommended that this method be given more careful study under a wider variety of conditions with an eye toward adopting it as a standard technique, with accompanying hardware design by an appropriate Army agency.

REFERENCES

Carleton, H. D., Sullivan, J. J., and Rooke, A. D., Jr. "Cratering and Ditching Experiments with Slurry Blasting Agents, FY75-FY78" (in preparation), U. S. Army Engineer Waterways Experiment Station, Vicksburg, Miss.

Headquarters, Department of the Army. 1968. "Field Fortifications," FM 5-15, Washington, D. C.

_____. 1971. "Explosives and Demolitions," FM 5-25, Washington, D. C.

Rand McNally. 1978. "Road Atlas, United States, Canada, and Mexico," 54th Annual Edition, New York, N. Y.

Strange, John N. 1961. "Analysis of Crater Data," Technical Report No. 2-547, U. S. Army Engineer Waterways Experiment Station, Vicksburg, Miss.

Table 1
Single-Shot Results

Shot Designation	Charge		Apparent Crater		True Crater Depth in.
	Weight lb	DOB in.	Diameter in.	Max. Depth in.	
2T1	0.75	11.0	43.5	15.5	42
2T2	0.75	12.0	43.0	10.5	49
3T1	0.75	16.2	43.0	12.0	49
3T2	0.75	16.2	45.0	12.0	51
3T3	0.75	16.2	40.0	11.5	47
4T1	0.75	21.2	40.0	9.0	54+*
4T2	0.75	21.2	59.0	9.0	54+*
5T1	0.50	20.5	47.0	17.0	NM**
5T2	0.50	32.5	43.0	20.5	NM**
5T3	0.50	14.5	47.0	18.0	NM**

* Exceeded depth of probe.

** NM not measured.

Table 2
Double-Shot Results*

Shot Designation	Upper Charge		Lower Charge		Apparent Diameter in.	Crater Maximum Depth in.	Depth to Top of Camouflet in.	Remarks
	Weight lb.	DOB in.	Weight lb.	DOB in.				
6T1	0.50	18.0	0.50	34.2	39.0	37.0	30.0	Upper charge misfired
6T2	0.75	18.0	0.50	34.2		26.0	16.0	Upper charge misfired
6T3	0.50	18.0	0.75	34.2		27.0		
6T4	0.75	17.5	0.75	34.2	48.0			
7T1	0.50	21.5	0.50	34.2	36.0	14.0		
7T2	0.75	22.0	0.50	34.2		26.0	16.0	Upper charge misfired
7T3A	0.50	22.0	0.75	34.2		38.5	17.0	Upper charge misfired
7T3B	0.75	22.0	0.50	34.2	45.0	10.0		
7T3C	0.50	22.0	0.75	34.2	47.0	21.0		
7T4	0.75	22.0	0.75	34.2	43.0	17.0		
7T5	0.50	20.2	1.00	34.2	48.0	34.0		
7T6	0.75	22.0	1.00	34.2	45.0	12.0		
8T1	0.50	15.2	1.00	34.2	46.0	17.0		
8T2	0.75	15.2	1.00	34.2	45.0	21.0		
8T3	0.75	17.2	1.00	34.2	46.0	21.0		
8T4	0.75	20.2	1.00	34.2	36.0	15.0		
8T5	0.75	22.2	1.00	34.2	41.0	14.0		
8T6	0.75	16.2	1.00	34.2	42.0	11.0		
8T7	0.75	12.2	1.00	34.2	37.0	18.0		
9T1	1.00	16.2	1.00	24.0	52.0	24.0		
9T2	1.00	16.2	1.00	30.0	54.0	26.0		
10T1**	0.50	12.0	1.00	34.0	46.0	36.0		
11T1 ⁺	0.62	15.9	1.25	31.8	70.0	26.4		

* All TNT charges fired at WES BBTS in September 1977, except as noted.

** Fired October 1977 with military dynamite in gravelly clay medium, Fort Belvoir, Virginia.

⁺ Fired December 1978 with C4 at BBTS.

APPENDIX A: STANDARDS FOR FOXHOLE CONSTRUCTION

1. Field Manual (FM) 5-15, "Field Fortifications," (Department of the Army 1968) provides standards for foxhole construction. The objectives of explosive excavation design are (a) to obtain immediate protection from small arms fire (cover), and (b) to obtain a crater suitable for completion by hand tools, as by removal of loose soil and shaping of final dimensions.

2. Figure A1 is adopted from Figures 2-6, 2-8, and 2-20 of FM 5-15, showing an individual foxhole and a design for a crew-served weapon (machinegun). Several dug-in positions for crew-served weapons are contained in FM 5-15; additional research would be necessary to determine what applications the expedient design in this report might have for these various positions.

3. It is recognized that FM 5-15 is currently under consideration for revision, and that doctrinal changes have taken place in the area of individual protection. It is not felt, however, that these contemplated changes significantly affect this study.

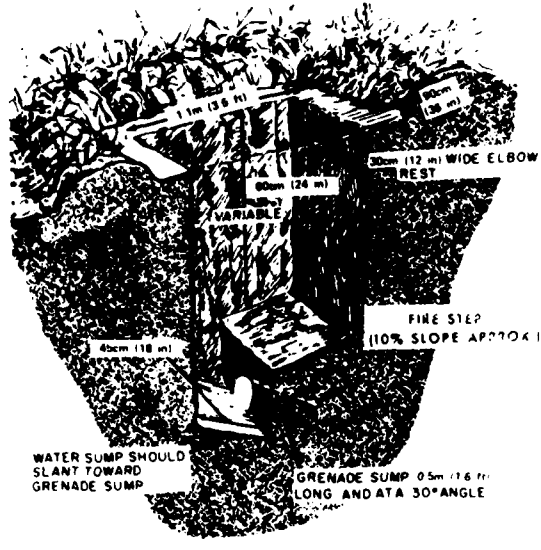

a. Individual foxhole



b. Use of individual foxhole (note partial overhead cover)

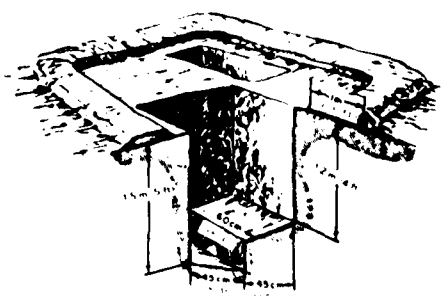
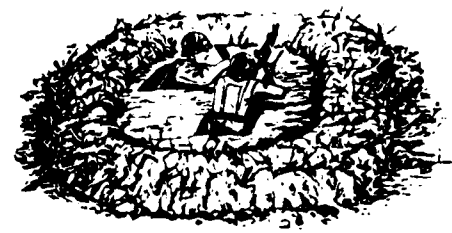

c. Foxholes configured for crew-served weapon

Figure A1. Standards for foxholes

APPENDIX B: 1977 CONFERENCE ON EXPLOSIVE FOXHOLE EXCAVATION

The following pages reproduce the letter announcement of a 1977 conference on explosive foxhole excavation and the minutes of that conference. These documents serve to give the reader a better understanding of previous as well as current thinking. Abbreviations not otherwise explained in these pages are LOA - letter of authorization and QMR - qualitative materiel requirement.

Department of the Army
U.S. Army Mobility Equipment Research & Development Center
Fort Belvoir, Virginia 22060

DRDME-Z

25 Aug 1977

SUBJECT: Explosive Foxhole Digger

Commander, 82nd Airborne Division, ATTN: AFVCGC-O, Ft Bragg, NC 28307
Commandant, US Army Infantry School, ATTN: ATCD-CD-MS, Ft Benning, GA 31905
Commandant, US Army Engineer School, ATTN: ATSE-CDM, Ft Belvoir, VA 22060
Commander, US Army Engineer Waterways Experiment Station, ATTN: WESNS,
PO Box 631, Vicksburg, MS 39180

1. Reference: Required Operational Capability (ROC) for the Explosive Foxhole Digger (EXFOD), TRADOC ACN 43901 (Proposed Draft).

2. The 82nd Airborne Division drafted a Letter Requirement (LR) for a foxhole digger. The referenced PROC was drafted by the Engineer School in response to the draft LR. The PROC was informally provided to MERADCOM for preliminary comments (Inclosure 1). In reviewing the PROC and the requirement for the existing Explosive Kit, Foxhole Digger (NSN 1375-00-999-2694) (see Inclosure 2), some questions become apparent regarding the need for a new item development.

3. In order to resolve these questions and to insure that a new ROC accurately defines needs, it is requested that each addressee provide a representative to attend a meeting at MERADCOM on 5 October 1977. At this meeting a film and a possible live demonstration of the existing digger will be seen.

4. MERADCOM point of contact for this meeting will be Mr. H. Smith, AUTOVON 354-5876, Commercial (703) 664-5876.

2 Incl
as

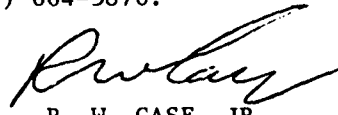

R. W. CASE, JR.
LTC, Corps of Engineers
Acting Commander



DEPARTMENT OF THE ARMY
US ARMY MOBILITY EQUIPMENT RESEARCH & DEVELOPMENT COMMAND
FORT BELVOIR, VIRGINIA 22060

DRDME-XS

11 Oct 1977

SUBJECT: Minutes - Foxhole Digging Aid Conference

Commander, US Army Armament R&D Command, ATTN: DRDAR-LCU-T, Dover, NJ 07801
Commander, 82nd Airborne Division, ATTN: AFVCOO-O, Ft Bragg, NC 28307
Commander, US Army Infantry School, ATTN: ATCD-CD-MS, Ft Benning, GA 31905
Commander, US Army Engineer School, ATTN: ATSE-CDM, Ft Belvoir, VA 22060
Commander, US Army Engineer Waterways Experiment Station, ATTN: WESNS,
PO Box 631, Vicksburg, MS 39180

1. Reference letter to your command dated 25 August 1977 requesting representation at a conference to discuss a proposed new requirement for an explosive foxhole digger.
2. Unfortunately, the 82nd Airborne was not represented at the conference. Minutes containing two proposed courses of action are transmitted for your information (Inclosure 1).
3. Point of contact is Harry C. Smith, AV 354-5876.

FOR THE COMMANDER:

1 Incl
as

A handwritten signature in black ink, appearing to read "Stuart A. Kilpatrick", is written over the typed name.

STUART A. KILPATRICK
Acting Chief
Counter Intrusion Laboratory

Minutes - Foxhole Digging Aid Conference

Location: MERADCOM, Ft Belvoir, VA.

Date: 5 Oct 1977.

Present: List of attendees (Incl 1).

Purpose: To discuss a proposed new requirement for a foxhole digging aid.

Summary: An agenda of the conference is attached as Inclosure 2. Inclosure 3 contains information presented by Mr. Smith in describing anticipated performance of the three devices discussed and their physical characteristics. A projection was also made, estimating the size device required to meet the proposed requirement as originated by the 82nd Airborne Division.

Technical, operational and logistical problems, implications and proposed solutions were discussed in detail. CPT Woodbury talked briefly about a proposal to combine an auger with the entrenching tool and use of available explosives for the cratering charge. It can generally be stated that the following points were agreed upon:

1. The standard item (officially the Explosive Kit, Foxhole Digger but also referred to as the EL-4) is not satisfactory for use in perma frost, does not produce an instant foxhole, but is useful in loosening the soil to make manual digging much easier.
2. Little is known about the general acceptance of the EL-4 because troops have never had the opportunity to work with it.
3. The 82nd Airborne's stated requirement is for an application under unique conditions and is not appropriate or representative of the average infantryman's need.
4. The introduction of new, larger, or heavier items of equipment for individual use was viewed with great concern, because of the currently overburdened logistical system.

The demonstration was an attempt to show the effects of various weight cratering charges placed at optimum depths, as determined by past experimental programs. The soil conditions were not representative of a broad average, hence, results were quite misleading and not worthy of consideration. Operational firing of the last remaining EL-4 produced expected results; no immediate hole but an area of well pulverized soil approximately four feet in diameter and three feet deep. The soil was very dry, gravelly and hard.

Proposed Action: The following course of action was agreed upon, initially falling basically in Mr. Abbott's area of responsibility:

1. Request procurement of a minimum of 2500 standard digging aids to permit evaluation and use by a variety of troop units as a means of determining acceptance by the Army. Administrative procedures required are undetermined at this time.
2. Process the 82d Airborne Division request as a special requirement, not as one designed to satisfy all infantry troops.

Harry Smith
HARRY SMITH
Project Engineer
Sensors & Barriers Division
Counter Intrusion Laboratory

FOX HOLE DIGGER MEETING

5 October 1977

Attendees:

Jack Abbott	U.S. Army Eng School	AV 354-1580
Harry Smith	MERADCOM	AV 354-5876
Frank Tremain	MERADCOM	AV 354-5876
R. Stone	ARRCOM - QAE-P	AV 880-5386
M. G. Stone	ARRADCOM	AV 880-2575
Jerold R. Dodds	USAIS	AV 835-5314
CPT James R. Cantrell	USAES	AV 354-3777
S. A. Kilpatrick	MERADCOM	AV 354-5877
Harry D. Painton	USAES	AV 354-5976
Harry J. Peters	MERADCOM	AV 354-5877
Ben Barker	MERADCOM	AV 354-5741
CPT George A. Woodbury	WES, Vicksburg, Miss.	

Incl 1

FOXHOLE DIGGING AID

5 October 1977

(Bldg 399, Conference Room)

1000	Purpose of Meeting	Tremain
1010	Historical Review	Smith
1050	Film	Smith
1035	Draft ROC	Abbott
1050	Critique	All
1130	LUNCH	
1300	Depart for T-6 Area	
1330	Demonstration (Simulated Aids with variable cratering charge sizes):	Lt Plank
	(1) ¼ lb	
	(2) ½ lb	
	(3) 1 lb	
	(4) 2 lb	
	(5) Explosive Kit Foxhole Digger	

Incl 2

FOXHOLE AIDS

ANTICIPATED PERFORMANCE

Device	Variable Soils	Frozen Soils	Permafrost
1. Explosive Foxhole Digger (5 lb - one shot)	36" deep 53" dia	50" deep, 34" dia. a. Surface only cracked when frozen 10" deep.	12" deep, 13" dia a. Insufficient for fuze functioning b. Shaped charge hole adequate for cratering charge - 7" deep.
2. Explosive Kit, Foxhole Digger (1 lb - two shot)	34" x 45"	Limits on shaped charge; 8" Muskeg Limits on cratering charge; 16" deep in Muskeg	Unacceptable
3. Kit Explosive, Digging Aid L12A1 (UK Device; 3 unit, two shot)	Poorer than No. 2	Poorer than No. 2	Poorer than No. 2

Incl 3

FOXHOLE AIDS
PHYSICAL COMPARISONS

Device	Weight	Length	Dia.	Shaped Charge		Cratering Charge	
				Explosive	Expt. Wgt.	Explosive	Expt. Wgt.
1. Explosive Foxhole Digger (One shot)	5.0 lbs	27-1/4"	2 1/4"	95% RDX	100 gm	MBX-6	254 gm
2. Explosive Kit, Foxhole Digger (Standard)	1.0 lbs	7-3/8"	2 1/4"	Octol	117 gm	DBXN-1	162 gm
3. Kit Explosive, Digging Aid L12A1 (3 devices)	5.3 lbs		2 1/4"	92% RDX	93.4 gm	73% RDX	113.3 gm
4. As Indicated by Require- ments	10 lbs	30"	3 1/2"	RDX	908 gm	RDX	908 gm

Comparisons
(Requirements)

Characteristic	Original Requirement (1959)	Existing Item Requirement (1962)*	PROC (1977)
Device Weight	5 lb	1 lb	5 lb
Foxhole Size	About 48" deep Maximum Diameter 42"	Minimum depth 17" Minimum diameter 20" Acceptable performance in 8" frozen soil	Minimum depth 36" Minimum diameter 48"
Timing	Produce required hole in 2 min.	Unpack, assemble, and fire - less than 1 min.	Produce required hole in 2 min.
Bullet Impact	Will not explode or flash burn	Will not detonate main charges	Will not initiate explosive.

1959 Major Deficiencies - Too long, too heavy, non-performance within 2 minutes.
 Minor Deficiencies - Diameter of hole too large, failure on bullet impact.

*Type Classified in 1966.

The following paragraphs provide representative information on the two diggers developed and tested at MERADCOM.

FOXHOLE AID

A. Explosive Foxhole Digger¹

1. Packaged weight	5.0 lbs	
Packaged length	27 $\frac{1}{4}$ in.	
Height in firing position	31 in.	
Shaped Charge (95% RDX)	100 gm.	
Cratering Charge (MBX-6)	254 gm.	
2. Performance - Ft Churchill		
Permafrost	Insufficient penetration for fuze functioning	
	*(12 deep & 13 in. dia.)	
3. Ice	*Depth	*Diameter
	18"	48"
	20"	48"
	19"	48"
4. Frozen Soil		
10 in. frozen soil - surface only cracked	crater 50"* deep x	
34"* diameter.		
5. Variable Soil	*Depth	*Diameter
	36"	53"
(typical)	40"	50"
	40"	60"

¹Report 1552-TR, 28 October 1958

*Note: The dimensions listed are representative only.

6. Shaped Charge test on permafrost produced holes less than 1-1/4 in. dia. at depths of 5 in. and 3/4 in. dia. to depths of 7 in.

7. Cratering charge - When placed at optimum depth in hard soils, the hole was only 3½ ft deep (vs 4 ft desired). The 2 ft dia. at the bottom and the shallow depth indicated a larger cratering charge was required.

B. Explosive Kit, Foxhole Digger²

Model EL-4 (ET/ST) - Type Classified Standard-A for temperate zone use on 31 March 1966.

1. Packaged weight	1.07 lbs.	
Length	7.38 in.	
Shaped Charge (Octol-75% HMX, 25% TNT)	117 gm.	
Cratering Charge (PBXN-1)	162 gm.	
2. Performance (typical)	*Depth	*Diameter
Lean clay, frozen 2½ - 3 in.	34"	45"
Rocky clay	32"	47"
3. ET/ST model 3% dud rate (5% allowed, 1% desired)		

²Report 1934, September 1968

*Note: The dimensions listed are representative only.

EXPLOSIVE FOXHOLE DIGGER

(Comments on Proposed Draft ROC)

1. The user must decide whether or not there will be a requirement to satisfactorily operate in permafrost. Permafrost is very difficult and an item that will perform satisfactorily will cause an "over-kill" in almost all other situations.
2. The wide variation in soils makes it very difficult to design a device to perform within the narrow limits specified for a foxhole. A compromise must be worked out between the user and the designer, producing an item that will provide minimum protection under the most difficult conditions. An example is contained in the Technical Characteristics approved as a part of the 1962 OMR for a similar item (EL-4). The specific numbers should be reexamined for today's environment.
3. It should be made clear whether or not the device is to produce an instant foxhole in a specified time, or whether some manual removal of soil is expected. One approach might be to produce the minimum hole instantly, followed by manual spoil removal to produce the desired foxhole.
4. The user should examine his requirement for a one-shot device. Considerable bulk, length and cost and reliability are associated with this requirement vs a two-step device.
5. Immunity to small arms initiation should realistically be limited to insurance that neither the shaped charge, nor the cratering charge will be initiated. Protection against burning of the rocket propellant (if present), or initiation of the sensitive primers and firing train is not considered realistic.

6. A requirement for limiting the acoustic signature has not been stated. If the acoustic signature is limited, the requirement should be stated as soon as possible.

7. If the user will be satisfied with a slightly larger (containing more explosive) version of the item Service Tested in 1959, then the requirement document may be a ROC, however, if the requirements as relate to items 1, 2, 3 and 5 above are not tempered and considered carefully, as indicated, then the appropriate document would be a LOA, permitting 6.3 work before entering the 6.4 effort.

In accordance with letter from DAEN-RDC, DAEN-ASI dated 22 July 1977, Subject: Facsimile Catalog Cards for Laboratory Technical Publications, a facsimile catalog card in Library of Congress MARC format is reproduced below.

Woodbury, George A.

An expedient method for excavation of foxholes : final report / by George A. Woodbury, Allen D. Rooke, Jr. (Structures Laboratory, U.S. Army Engineer Waterways Experiment Station). -- Vicksburg, Miss. : The Station ; Springfield, Va. : available from NTIS, [1981].

45 p. in various pagings : ill. ; 27 cm. -- (Miscellaneous paper / U.S. Army Engineer Waterways Experiment Station ; SL-81-15)

Cover title.

"June 1981."

"Prepared for Office, Chief of Engineers, U.S. Army under MEACE Project No. 4A762719AT40."

Bibliography: p. 27.

1. Augers. 2. Explosives, Military. 3. Military art and science. 4. Nuclear excavation. 5. Nuclear explosions. I. Rooke, Allen D., Jr. II. United States. Army. Corps of Engineers. Office of the Chief of

Woodbury, George A.

An expedient method for excavation of foxholes : ... 1981.
(Card 2)

Engineers. III. U.S. Army Engineer Waterways Experiment Station. Structures Laboratory. IV. Title V. Series: Miscellaneous paper (U.S. Army Engineer Waterways Experiment Station) ; SL-81-15.
TAT.W34m no.SL-81-15