

AD-A103 050

ROYAL SIGNALS AND RADAR ESTABLISHMENT MALVERN (ENGLAND)
MEDICAL THERMOGRAPHY WITH A PYROELECTRIC VIDICON CAMERA.(U)
MAR 81 D E BURGESS
RSRE-MEMO-3365

F/6 6/5

UNCLASSIFIED

DRIC-BR-79226

NL

1-1
30300



END
DATE
FILMED
81
DTIC

UNLIMITED

LEVEL



RSRE
MEMORANDUM No. 3365

ROYAL SIGNALS & RADAR ESTABLISHMENT

AD A103050

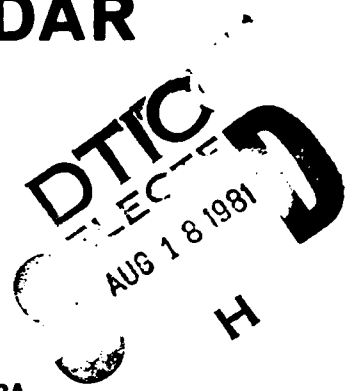

MEDICAL THERMOGRAPHY WITH A PYROELECTRIC VIDICON CAMERA

Author: D E Burgess

RSRE MEMORANDUM No. 3365

PROCUREMENT EXECUTIVE,
MINISTRY OF DEFENCE,
RSRE MALVERN,
WORCS.

81 8 18 164

UNLIMITED

ROYAL SIGNALS AND RADAR ESTABLISHMENT

Memorandum No 3365

TITLE: MEDICAL THERMOGRAPHY WITH A PYROELECTRIC VIDICON CAMERA.

AUTHOR: D. E. BURGESS

DATE: 11 MARCH 1981

SUMMARY

As a result of a visit by Mr F Ring of the Royal National Hospital for Rheumatic Diseases, Bath, to RSRE, including a demonstration of a pyroelectric vidicon camera and associated signal processing equipment, the equipment was taken to Bath and tested on patients at the hospital. This report describes the equipment used and the results obtained.

14 RE-MEMO-3365

1. DR. RING - 11.3.81

This memorandum is for advance information. It is not necessarily to be regarded as a final or official statement by Procurement Executive, Ministry of Defence

Copyright
C
Controller HMSO London

Accession For	<input type="checkbox"/>
WIS GR&I	<input type="checkbox"/>
DTIC TAB	<input type="checkbox"/>
Unannounced	<input type="checkbox"/>
Justification	<input type="checkbox"/>
By _____	
Distribution/	
Availability Codes	
Avail and/or	

401701

MEDICAL THERMOGRAPHY WITH A PYROELECTRIC VIDICON CAMERA

D E Burgess

LIST OF CONTENTS:

- 1 Introduction
- 2 The present state of medical thermography
- 3 Pyroelectric Vidicon camera equipment at RSRE
- 4 The medical trial
- 5 Results¹
 - 5.1 Rheumatic joints; an example of internal disease
 - 5.2 Ulcers and burns; surface injuries
 - 5.3 Diseases affecting blood flow
- 6 Future considerations¹
 - 6.1 Additional facilities
 - 6.2 Equipment integration
- 7 Conclusions
- 8 References
- 9 Figures

1 INTRODUCTION

For a number of years the Royal National Hospital for Rheumatic Diseases has used infrared thermal imaging on a regular basis for clinical diagnosis of patients' illnesses. Using equipment manufactured by Bofors, incorporating a cooled photon detector, with results collected and analysed in a PDP 8 mini-computer, the Physics Department has acquired considerable experience in the use of thermal imaging for the diagnosis of internal disease such as rheumatism, and for the observation of the healing of surface wounds such as burns and ulcers. The department has demonstrated the usefulness of these techniques and is keen to extend their use to other hospitals and to the study of other diseases.

During a visit to RSRE Mr Ring was shown the latest infrared sensitive pyroelectric vidicon cameras and associated signal processing equipment, and thought that the equipment was sufficiently sensitive to be of use in the medical field. Subsequently a trial was organised at Bath where the camera equipment was assessed in a hospital environment. The results of the trial and the conclusions reached afterwards form the basis for this report.

2 THE PRESENT STATE OF MEDICAL THERMOGRAPHY

The Bofors equipment described above is both expensive and bulky. It is not easily transportable, requiring that patients come to the equipment, and for these reasons the successes achieved at Bath have not been duplicated around the country's hospitals. One attempt to remedy this situation has been the funding by the Rank Prize Fund of the development of a thermal imager based

on the U.K. common modules. This equipment is now undergoing hospital trials, but as yet it does not promise the reduced cost necessary for its general use. What it does do is to demonstrate a very high performance, with a temperature sensitivity of below 0.1°C . Almost as good a temperature sensitivity as this, but with fewer picture points, is attained by the equipment made by AGA. Unfortunately again cost inhibits its use in all but the largest hospitals.

The pyroelectric vidicon television camera⁽¹⁾, incorporating an infrared sensitive television tube developed under funds supplied by the Ministry of Defence, has long been considered as a candidate equipment for medical thermography. It has the advantage of using relatively cheap technology⁽²⁾, and, operating at room temperature, it does not have the liquid nitrogen logistics problems of the equipments which use cooled detectors. To date however the lack of a commercially available system (pyroelectric camera and television picture monitor with image analysis accessories) has precluded its widespread acceptance as a medical tool. Nevertheless two medical trials using commercially available cameras are worthy of note.

Firstly a pyroelectric camera manufactured by Thermal Imaging was used at Edinburgh, by Dr Whatley⁽³⁾ to check for the successful connection of blood vessels after heart surgery. Secondly⁽⁴⁾ Mr Newman of the Southern General Hospital, Glasgow used an English Electric Valve Company camera to demonstrate that bed sores were not always the result of ignorant nursing, but often of bruising sustained before hospital admission. In both these trials the temperature and spatial sensitivity of the cameras was sufficient to perform the medical task. The simplicity of operation and portability of the pyroelectric cameras were also important factors in enabling these trials to take place. In particular the ability of the cameras to operate in any attitude (generally impossible when using cooled detectors with the danger of liquid nitrogen spillage from upturned dewars) ensured the minimum disturbance to patients and to normal operating practices.

3 PYROELECTRIC VIDICON CAMERA EQUIPMENT AT RSRE

RSRE has been at the forefront of the development of pyroelectric vidicon cameras during the past decade. During this time funds have been made available for the design and development in industry of lenses⁽⁵⁾ and vidicon tubes of the highest possible quality⁽⁶⁾, and cameras to complement these items have been made in-house⁽⁷⁾ and in industry⁽⁸⁾. Concurrently the application of electronic signal processing to television-type sensors in order to improve their performance has resulted in equipments being made to perform picture improvements by real time running integration⁽⁹⁾. In these equipments, known usually as integrating field stores, the random electronic noise which is different from one television scan to the next is reduced whilst unchanging picture signals are reinforced. Field stores are now commercially available from a number of suppliers.

By bringing together the best of the camera equipment described above, a running integration field store, and other units, RSRE have demonstrated the first real pyroelectric camera system (as opposed to a camera and a monistor). The system has a superior performance to a camera on its own, and, it is believed, to any camera made elsewhere, and incorporates a number of image analysis tools to aid picture interpretation. The elements of the system are as follows:

1. Lens.

Irtal 4,⁽⁵⁾ 50 mm focal length lens, manufactured with two aspheric germanium elements by Rank Taylor Hobson, Leicester, has an aperture of $f/0.7$.

2. Pyroelectric vidicon tube.

Ultra-high resolution infrared television tube manufactured by English Electric Valve Company⁽⁶⁾ with a reticulated detector surface (target) giving 40% higher resolution than standard tubes.

3. Camera.

Camera specially designed and built at RSRE to match the above lens and tube.

4. Signal Processor.

Running integration television signal processor built by Thorn-EMI. Increases the signal to random electronic noise by up to 8 times at the expense of a time constant for responding to changing scenes of 1.3 seconds; not generally a problem in medical situations.

Together these items have a limiting spatial resolution of 350 points per picture diameter and a peak to peak electronic noise equivalent to approximately 0.2°C at low spatial frequencies. The pyroelectric camera is not well suited to measuring absolute temperatures, but is ideal for measuring the temperature differences between scene areas. This is not considered to be a disadvantage in medical thermography, since one or more black body test objects can usually be introduced into the picture if absolute figures are needed.

5. Contouring equipment.

This unit, manufactured by Video Electronics, sets to peak white any part of a television picture which is between two preset voltages. The difference between the voltages is known as the window width and is one operator control, whilst the second control adjusts the window level. For a particular pyroelectric camera these controls may be calibrated in degrees centigrade and used to highlight all picture areas having the same range of temperatures.

4 THE MEDICAL TRIAL

The equipment described above was taken to the hospital at Bath for a one day trial in February 1981. It was set up in a temperature controlled room by the side of the Bofors imager so that its performance on routine thermography patients could be assessed whilst causing the minimum disruption to the hospital routine.

Amongst the patients seen during the day were sufferers from rheumatism in knees and hands, and one patient with an ulcer on his ankle. Results were recorded on a high quality video tape recorder for later processing and analysis at RSRE.

5 RESULTS

Video tape recordings were made of thermal images from five patients, all

of whom proved to have measurable skin temperature differences that could be associated with their diseases. For the purpose of this report two of these images are analysed; the first deals with an internal disease, the second with a surface injury. Additionally, a third investigation performed later is also described.

5.1 RHEUMATIC JOINTS; AN EXAMPLE OF INTERNAL DISEASE

One patient examined during the day had severe pain and swelling caused by rheumatism in his left knee. This type of pain and swelling usually leads to an increased localised skin temperature which was evident in his case. He stayed for 15 minutes in a temperature stabilised room without shoes and socks and with trousers rolled up, then stood in front of the pyroelectric camera. Figure 1 is a photograph taken at RSRE from a television monitor displaying the recorded video tape. In this and in the subsequent photographs black corresponds to cold whilst white corresponds to hot. The right (diseased) knee of the picture (the patient's left) is significantly hotter than the healthy knee, and a particularly hot area appears to the right and below the kneecap.

This picture is sufficient to determine the hot areas associated with the disease, but the medical diagnosis of the severity of the disease requires more quantitative measurements of the temperature differences within the scene. Accordingly, the data was replayed through the contouring equipment which was adjusted to give a contour width corresponding to 0.5° . The contour level was then stepped in intervals of 0.5° and at each step the monitor was photographed. As described above in section 3, the contouring unit operates by setting to peak white any picture area which lies within the grey shade window set by the operator.

Figure 2 is a composite of these results. The numbers below each photograph represent the equivalent contour temperature above the temperature of the coldest part of the picture. From an equipment point of view, since the contours are not overlapping, the residual electronic noise corresponds to a lower temperature than the 0.5° contour separation. From a medical viewpoint the maximum temperature difference between the healthy and the diseased knee is 4° .

5.2 ULCERS AND BURNS; SURFACE INJURIES

In the healing of both ulcers and burns it is of prime importance to determine how well the blood flow to the injured region is returning, since blood flow and healing go hand in hand. Since an increased blood flow near the skin surface will result in an increased skin temperature, then a positive thermal gradient towards such a wound means healing is occurring, whilst a negative gradient shows a failure of the healing mechanism, and requires medical intervention.

One of the patients seen during the day had a small ulcer on his ankle, shown in the upper photograph of figure 3. The area covered by the lower thermal view is shown by the black corner markings on the upper visible photograph. As in the previous example, some information may be gleaned from the thermal picture. The scab at the centre of the ulcer has no blood flow to it and is cooler than its surroundings. The good sign of the positive temperature gradient towards the ulcer is evident. Again however, a better medical judgement may be made from more quantified data. The contouring unit was used to produce the composite figure 4. The top left picture repeats the thermal scene of figure 3 for comparison.

Contour width and step controls were again set to 0.5° . From the numbers below the pictures the temperature difference between the scene edges and the edge of the ulcer is 4°C . This figure and the shape of the temperature contours could be used by a doctor to chart the healing process.

5.3 DISEASES AFFECTING BLOOD FLOW

During the day an experiment was done on the hand of Mr Ring. It is known that some patients suffering from high blood pressure also suffer from Raynaud's disease, where a reduction is evident in the body's ability to respond to a cold stimulus by increasing blood circulation. This disease can be detected⁽¹⁰⁾ by measuring the temperature difference between the centre of the back of the patient's hand and their fingers after the hand has been immersed in cold water for a few minutes. The equipment proved to be sufficiently sensitive to measure the temperature difference of interest of the healthy hand, but the recorded data subsequently proved to be faulty. The same cold stimulus was later applied to the author's hand to produce the results presented here. Since the temperature differences produced in this experiment were larger than those experienced in the others, the contour separation was increased to 0.6°C for the results shown in figure 5. A measurement of the temperature difference between the fingers and the back of the hand (3°C in this case), and an analysis of the way this value changes with time can be used by a doctor to decide on the degree of seriousness of the disease.

6 FUTURE CONSIDERATIONS

The above sections describe three dissimilar disease states that have been successfully monitored with the pyroelectric vidicon camera system as it is presently constructed. The next step is to decide what additional facilities could usefully be added to the equipment, then it needs to be redesigned into an integrated unit, considering all the time the requirements for portability and low cost.

6.1 ADDITIONAL FACILITIES

Discussions between Mr Ring and the author have highlighted two additional facilities which could usefully be added to the equipment to improve its performance in the medical role.

Firstly, although the contouring unit worked satisfactorily in post-hospital data analysis when multiple photographs can be taken at different temperature window settings, in a real medical environment several different contours would be needed simultaneously. The obvious solution to this problem would be to use coloured contours, with different colours corresponding to different temperature windows. Equipments to produce multiple contours and to display them on a colour monitor are now commercially available, and for example are being used in medical applications with the AGA thermal imagers.

Secondly, the test for Raynaud's disease described in section 5.3 could be done by relatively unskilled personnel if a facility existed for electronically superimposing two movable boxes on the displayed picture, with circuits to compute and to display in some form the average temperature difference between the selected picture areas. Although no equipment exists at present to perform this function, the design and manufacture of such a unit would be straight forward.

Further, since the visit to Bath it has been suggested that for additional analysis in research activities it would be helpful to be able to transfer data in digital form from the integrating field store into the memory of a mini/micro computer. This function would not be difficult to implement.

6.2 EQUIPMENT INTEGRATION

Figure 6 shows schematically the size of the equipment used in the trial. The technology used, particularly in the case of the field store, is several years old, and it is not now representative of current possibilities. A complete system has been designed recently at RSRE incorporating the additional facilities described in the previous section. An example of how this equipment might be packaged in miniaturised form is shown in figure 7. All the electronics could be built into a single unit which would be easily transportable on a wheeled trolley, with the camera head on a lightweight tripod.

Since the cost of electronic components continues to fall, the use of an electronics package to improve the performance of the pyroelectric vidicon camera becomes more attractive. The cost of the components to perform all the additional functions is less than £1,000, so that once the design has been finalised the complete system could be on sale at less than £10,000.

7 CONCLUSIONS

An optimised pyroelectric vidicon camera with its associated signal processing electronics has been constructed, and has been demonstrated to have a sufficiently high performance to be of use in the medical field. Preliminary designs have been produced at RSRE to enable both the individual units and the additional facilities to be incorporated into a single small portable equipment which, hopefully, could sell for less than £10,000. Funds are now required to put this design into production so that the equipment can fulfil the promise it has already shown in the diagnosis of illnesses.

REFERENCES

- 1 R Watton. 'Pyroelectric Materials: Operation and performance in thermal imaging camera tubes and detector arrays'. Ferroelectrics, Vol 10, 1976.
- 2 R Watton, B Harper and D Burgess. 'Infrared T.V.: An inexpensive portable pyroelectric camera' Infrared Physics, 1976, Vol 16.
- 3 J W E Brydon, A K Lambie and D J Wheatley. 'Thermographic visualisation of coronary artery blood flow during by-pass surgery' J Med Engng Technol, Vol 3, March 1979, pp 77-80.
- 4 P Newman. 'Applications of a mobile thermograph' Human Metabolism and Heat, Anglo-Dutch Thermographic Society, 1980.
- 5 'Aspherised Optics' Rank Optics, Taylor Hobson, Leicester, technical literature.
- 6 R Watton, D Burgess and P Nelson. 'The thermal behaviour of reticulated targets in the pyroelectric vidicon' Infrared Physics, Vol 19, 1979, pp 683-688.
- 7 R Watton, D Burgess and B Harper. 'The pyroelectric vidicon: a new technique in thermography and thermal imaging' Journal of Applied Science and Engineering A, Vol 2, 1977 pp 47-63.
- 8 Technical literature from English Electric Valve Co., Chelmsford, Essex and Thermal Imaging Lt, Bodmin, Cornwall.
- 9 CCD field store in television noise reducer. "Notebook", BBC Engineering December 1978, p 4.
- 10 E F J Ring. 'Quantitative medical thermography' S P I E Vol 110, 1977 pp 78-84.

REPORTS QUOTED ARE NOT NECESSARILY
AVAILABLE TO MEMBERS OF THE PUBLIC
OR TO COMMERCIAL ORGANISATIONS

LIST OF FIGURES

- 1 Thermal picture of a patient's knees.
- 2 Temperature contoured thermal pictures of the knees
- 3 Visible and thermal pictures of an ulcerated ankle.
- 4 Temperature contoured thermal pictures of the ulcerated ankle.
- 5 Temperature contoured thermal picture of a hand.
- 6 Configuration of present equipment.
- 7 Possible configuration of integrated equipment.



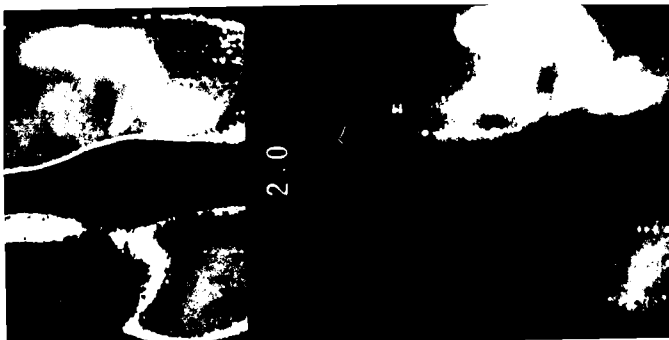

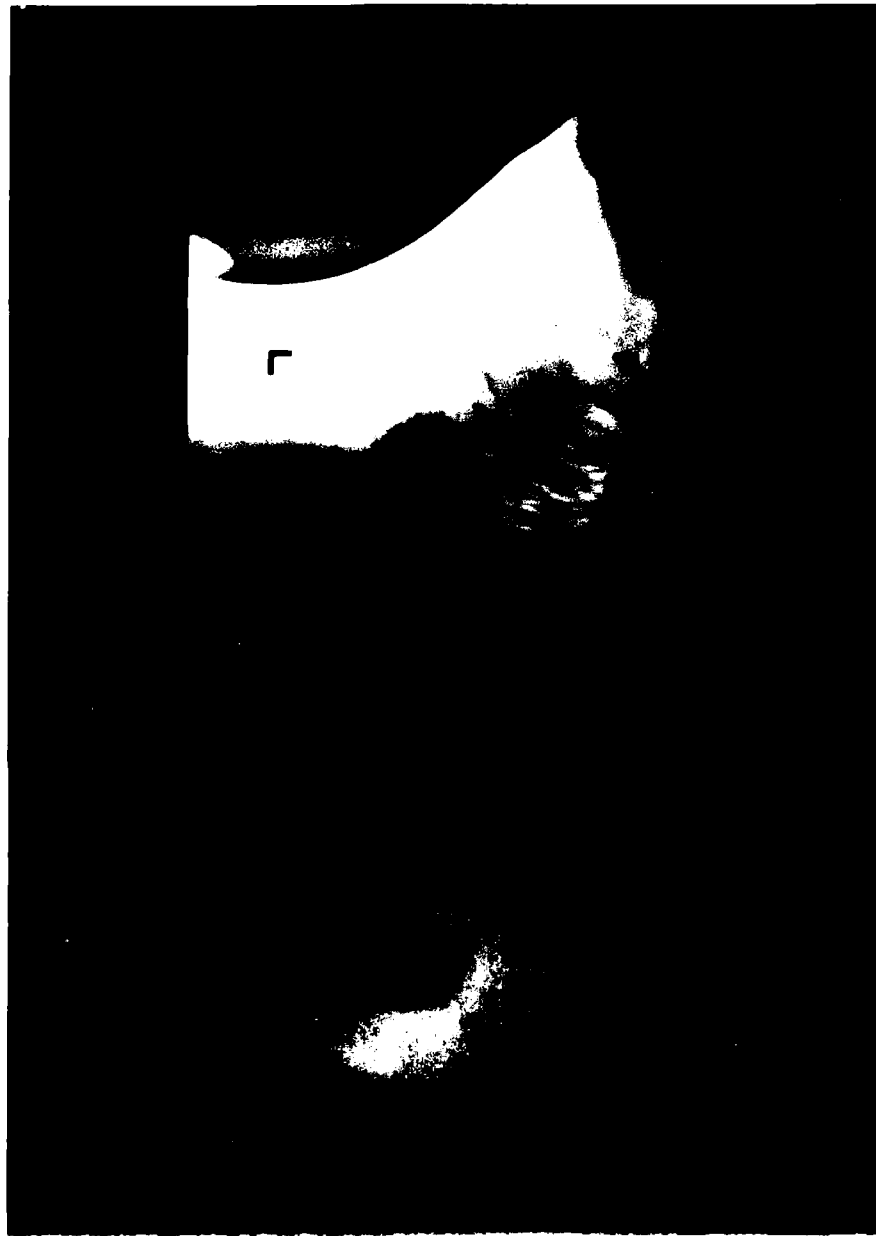





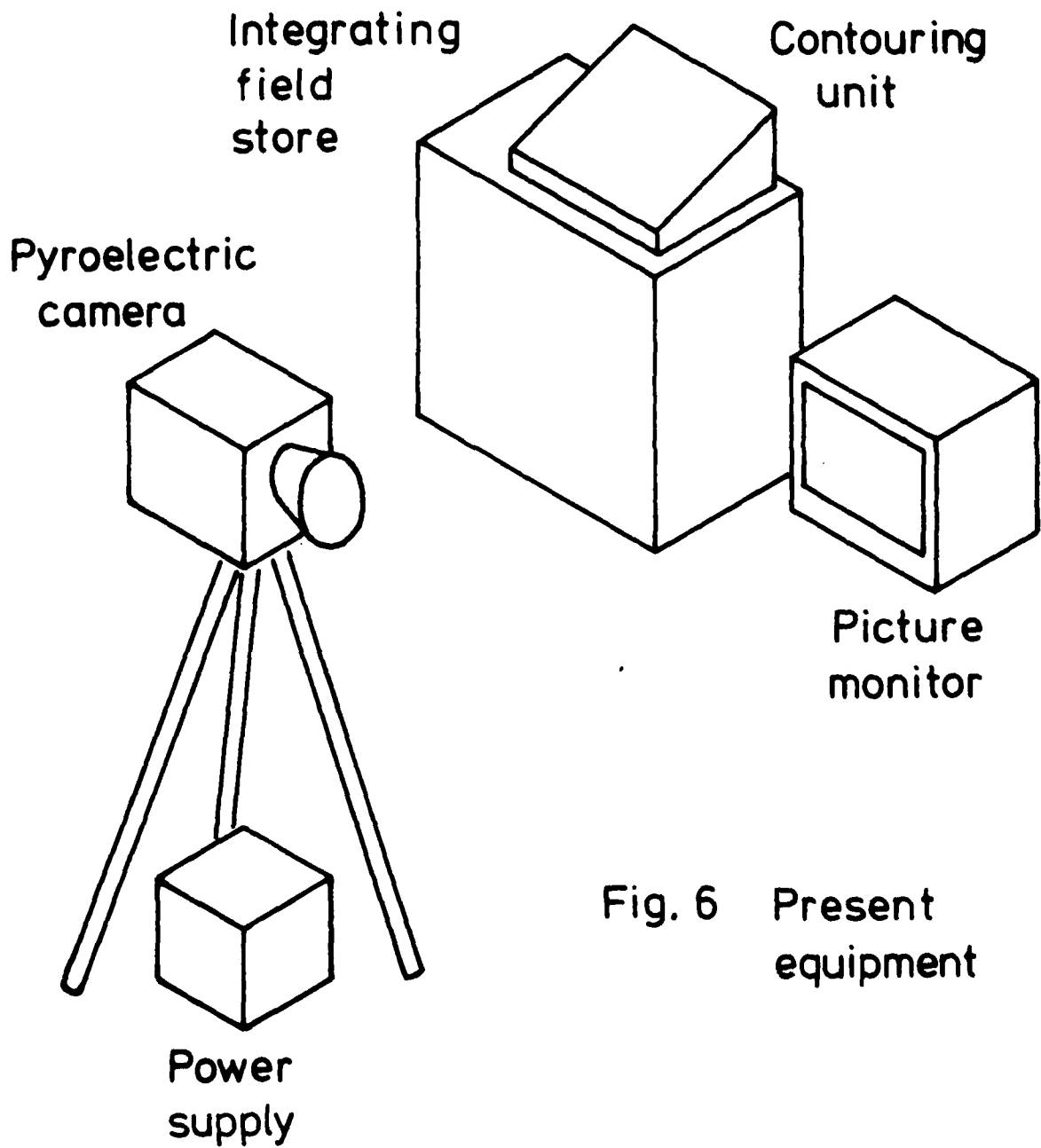
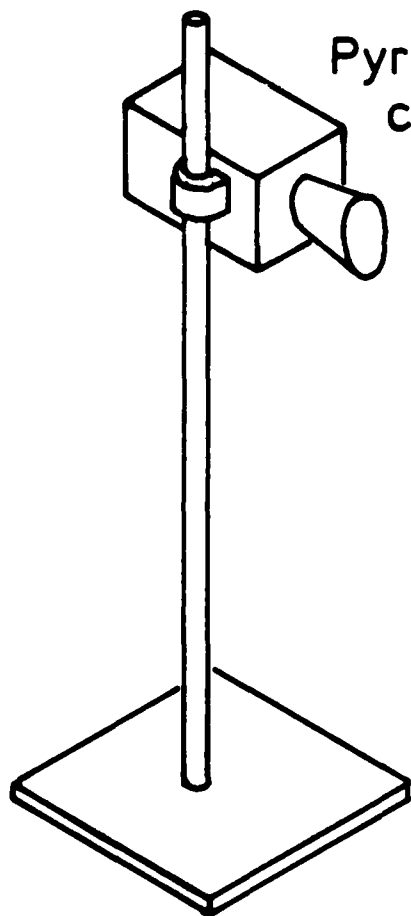
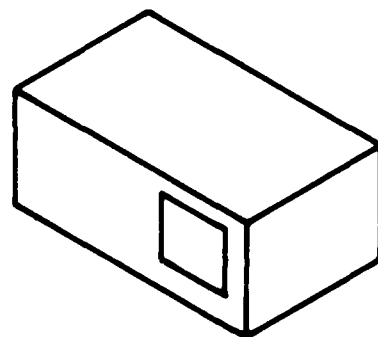

Fig. 6 Present equipment



Pyroelectric
camera



Integrating field store
includes
colour contouring
temperature measuring
colour monitor
computer interface

Fig. 7 Possible configuration of
integrated equipment

