

AD-A103 055

DIKEWOOD INDUSTRIES INC ALBUQUERQUE NM F/G 20/14
ELECTROMAGNETIC TOPOLOGICAL DESCRIPTION OF A GROUND-BASED MISSILE--ETC(U)
JUN 80 E F VANCE F29601-76-C-0149

UNCLASSIFIED

AFWL-TR-79-132

ML

1 of 1
4700000



END
DATE
FILMED
9-80
DTIC

AFWL-TR-79-132

① LEVEL II

AFWL-TR-79-132

ELECTROMAGNETIC TOPOLOGICAL DESCRIPTION OF A GROUND-BASED MISSILE LAUNCH CONTROL CENTER

E. F. Vance

Dikewood Industries, Inc
1009 Bradbury Drive, SE
Albuquerque, NM 87106

June 1980

Final Report

DTIC
ELECTE
AUG 19 1981
S D
B

Approved for public release; distribution unlimited.

AIR FORCE WEAPONS LABORATORY
Air Force Systems Command
Kirtland Air Force Base, NM 87117

81 8 18 083

AD A103055



DTIC FILE COPY

This final report was prepared by the Dikewood Industries, Inc, Albuquerque, New Mexico, under Contract F29601-76-C-0149, Job Order 37630115 with the Air Force Weapons Laboratory, Kirtland Air Force Base, New Mexico. Dr. Michael G. Harrison (NTYE) was the Laboratory Project Officer-in-Charge.

When US Government drawings, specifications, or other data are used for any purpose other than a definitely related Government procurement operation, the Government thereby incurs no responsibility nor any obligation whatsoever, and the fact that the Government may have formulated, furnished, or in any way supplied the said drawings, specifications, or other data, is not to be regarded by implication or otherwise, as in any manner licensing the holder or any other person or corporation, or conveying any rights or permission to manufacture, use, or sell any patented invention that may in any way be related thereto.

This report has been authored by a contractor of the United States Government. The United States Government retains a nonexclusive, royalty-free license to publish or reproduce the material contained herein, or allow others to do so, for the United States Government purposes.

This report has been reviewed by the Public Affairs Office and is releasable to the National Technical Information Service (NTIS). At NTIS, it will be available to the general public, including foreign nations.

This technical report has been reviewed and is approved for publication.

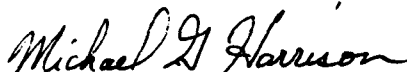
MICHAEL G. HARRISON, PhD
Project Officer

J. PHILIP CASTILLO, PhD
Chief, Electromagnetics Branch

FOR THE DIRECTOR

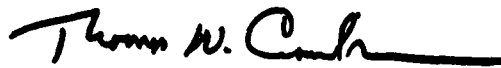
THOMAS W. CIAMBRONE
Colonel, USAF
Chief, Applied Physics Division

UNCLASSIFIED

SECURITY CLASSIFICATION OF THIS PAGE (When Data Entered)

19 REPORT DOCUMENTATION PAGE		READ INSTRUCTIONS BEFORE COMPLETING FORM	
1. REPORT NUMBER 18 AFWLTR-79-132	2. GOVT ACCESSION NO. AD-A103	3. RECIPIENT'S CATALOG NUMBER 055	
4. TITLE (and Subtitle) 16 ELECTROMAGNETIC TOPOLOGICAL DESCRIPTION OF A GROUND-BASED MISSILE LAUNCH CONTROL CENTER. / 9		5. TYPE OF REPORT & PERIOD COVERED Final Report	
7. AUTHOR(s) E. F. Vance		6. PERFORMING ORG. REPORT NUMBER	
9. PERFORMING ORGANIZATION NAME AND ADDRESS Dikewood Industries, Inc. 1009 Bradbury Drive, SE Albuquerque, NM 87106		8. CONTRACT OR GRANT NUMBER(s) F29601-76-C-0149 ✓	
11. CONTROLLING OFFICE NAME AND ADDRESS Air Force Weapons Laboratory (NTYE) Kirtland Air Force Base, NM 87117		10. PROGRAM ELEMENT, PROJECT, TASK AREA & WORK UNIT NUMBERS 64711F/37630115	
14. MONITORING AGENCY NAME & ADDRESS (if different from Controlling Office) 15 3705 / 17 9 L 1		12. REPORT DATE June 1980	
		13. NUMBER OF PAGES 28	
		15. SECURITY CLASS. (of this report) Unclassified	
		15a. DECLASSIFICATION/DOWNGRADING SCHEDULE	
16. DISTRIBUTION STATEMENT (of this Report) Approved for public release; distribution unlimited. 16			
17. DISTRIBUTION STATEMENT (of the abstract entered in Block 20, if different from Report)			
18. SUPPLEMENTARY NOTES			
19. KEY WORDS (Continue on reverse side if necessary and identify by block number) Ground System Electromagnetic Pulse Topology Interaction			
20. ABSTRACT (Continue on reverse side if necessary and identify by block number) A representative set of EMP interaction problems is identified for a ground-based system from its topology. Approaches to the solution of these problems are briefly described. The problems identified for illustration are the AC power unit, the buried communication cables, the communication antenna and feed cable, the silo lid, and the internal power cables.			

DD FORM 1 JAN 73 1473

UNCLASSIFIED

SECURITY CLASSIFICATION OF THIS PAGE (When Data Entered)

11-11

K

UNCLASSIFIED

SECURITY CLASSIFICATION OF THIS PAGE(When Data Entered)

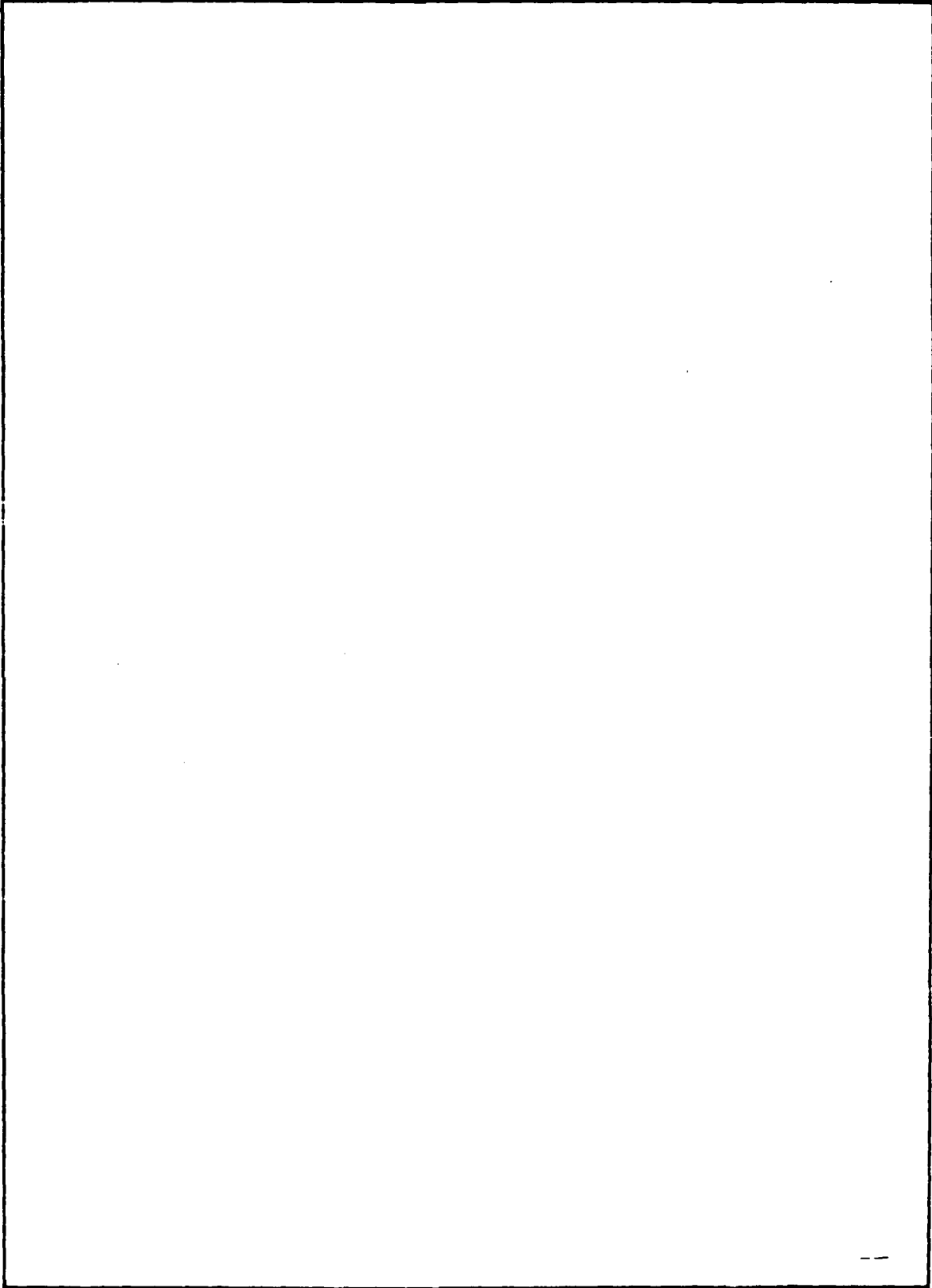

UNCLASSIFIED

SECURITY CLASSIFICATION OF THIS PAGE(When Data Entered)

CONTENTS

<u>Section</u>	<u>Page</u>
I INTRODUCTION	5
II SHIELD TOPOLOGY	7
III EXTERNAL INTERACTION	10
1. AC POWER	10
2. BURIED COMMUNICATION CABLE	12
3. COMMUNICATION ANTENNA AND FEED CABLE	14
4. LID EXCITATION	16
IV INTERNAL INTERACTION	20
1. INTERNAL POWER CABLES	22
2. APERTURE EXCITATION OF LAUNCH TUBE	24

Accession For	
NTIS GRA&I	<input checked="" type="checkbox"/>
DTIC TAB	<input type="checkbox"/>
Unannounced	<input type="checkbox"/>
Justification	
Ex	
Distribution/	
Availability Codes	
Dist	Special
A	

ILLUSTRATIONS

<u>Figure</u>		<u>Page</u>
1	Components of a Ground-Based Launcher	6
2	Identification of System Shields	8
3	Shielding Topology	9
4	External Coupling and Propagation Through AC Power System	11
	(a) AC Power Circuits	11
	(b) Equivalent Source for Overhead Lines	11
	(c) Source Transferred to Facility Shield Penetration	11
5	External Coupling and Propagation Through Shielded Underground Communication Cable	13
	(a) Underground Communication Cable	13
	(b) Bulk Current in Cable	13
	(c) Wire Current at Facility Shield Penetration	13
6	External Coupling and Propagation Through External Antennas and Feeds	15
	(a) Communication Antenna and Feed	15
	(b) Contribution of Antenna Element	15
	(c) Contribution of Antenna Base and Cable Current and Charge	15
	(d) Equivalent Source at Facility Shield Penetration	15
7	Aperture Coupling Configuration	17
8	External Coupling to Launcher Lid Apertures	18
9	Simplified Block Diagram of Internal Components of Launcher System	21
10	Propagation of Penetrating Power Current to Internal Circuits	23
	(a) Internal Propagation -- Conductor/Shield Mode	23
	(b) Shield Excitation by Internal Voltage and Current	23
11	Aperture Coupling to Launcher/Vehicle Cavity	26

ILLUSTRATIONS (Cont'd)

<u>Figure</u>		<u>Page</u>
12	Current in Umbilical Cable Conductors	27
	(a) Norton Equivalent Circuit of Coaxial Cavity	27
	(b) Umbilical Cable Configuration	27
	(c) Umbilical Cable Input Admittance	27
12	Continued	
	(d) Current and Charge Distribution on Umbilical Cable	28
	(e) Current in Umbilical Cable Conductors	28

SECTION I
INTRODUCTION

Permanent ground-based installations such as rocket vehicle launchers and communication facilities are generally characterized by large external appendages such as power lines and communication cables, and by facility shields of various qualities. For the present example, we will use the rocket vehicle launcher illustrated in figure 1. Commercial power is normally used to operate the system and to perform expendable station-keeping operations. Communication and monitoring from a remote location is done through a buried, shielded communication cable. An alternate communication channel may be a radio system; hence an external radio receiving antenna and feed cable may be provided.

The system illustrated in figure 1 is considerably simplified; operational systems often contain many other external elements such as outside lightning, WWV receivers, local radio communications systems, external power outlets, intrusion alarm sensors, radiation/EMP monitors, local telephone cables, etc., as well as plumbing for water, sewage, fuel, etc. However, the elements shown are representative of the external coupling elements, and they will be used to illustrate coupling and penetration of long overhead conductors, long buried conductors, and "local" antennas and antenna feeds.

In addition, as will be discussed later, it will be assumed that the launch tube lid is imperfect so that external magnetic fields may penetrate through the joint between the lid and the launch tube walls. Thus this example will also demonstrate the effect of aperture coupling through the shield.

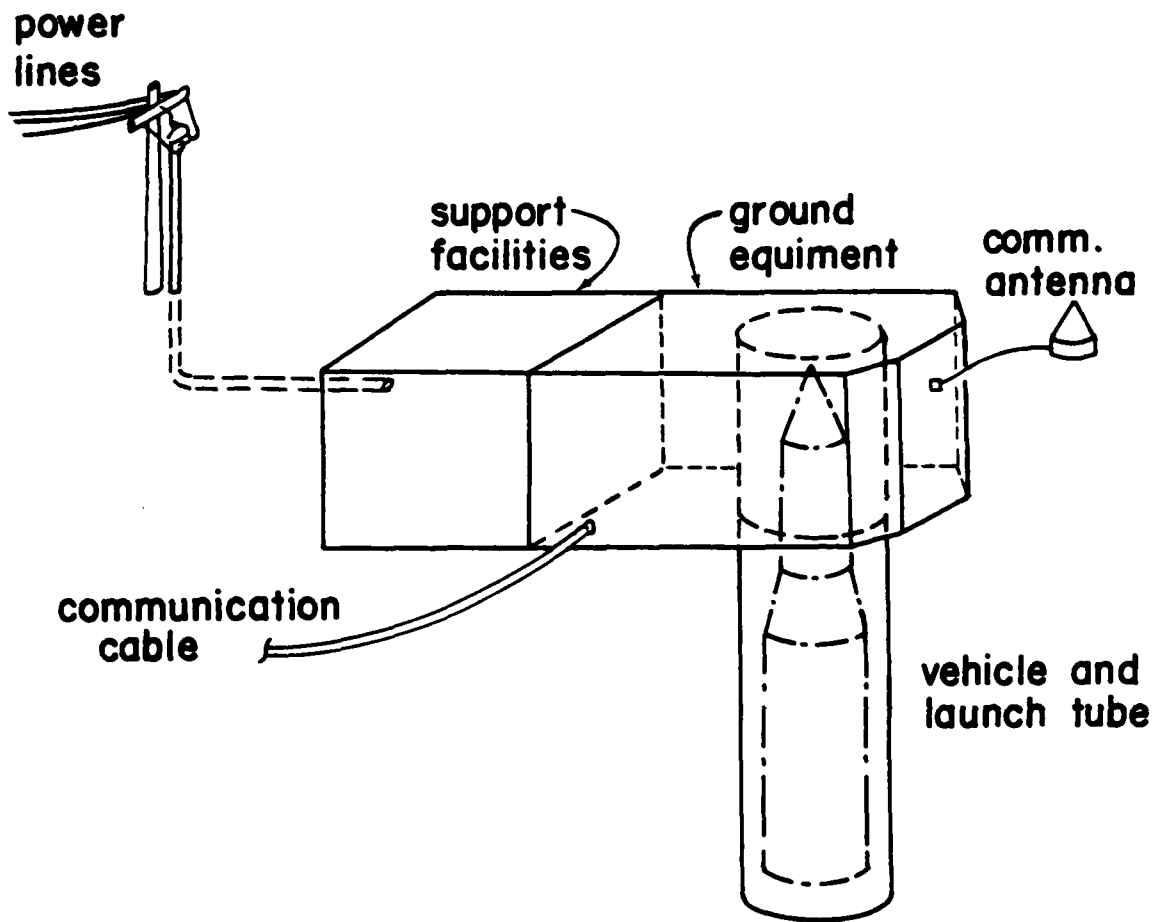

Figure 1. Components of a Ground-Based Launcher

SECTION II
SHIELD TOPOLOGY

The primary facility shield for the system will be the welded steel walls of the launch tube and ground equipment compartment. This shield is identified in figure 2 as shield 1 with symbol S_1 . Except for the launch tube lid and the holes for cable entries, the outside envelope of this shield is considered to be continuous steel plate.

Within the primary shield, there are secondary shields that form the housings for power and signal processing circuits. These secondary shields are identified as shield (2,1) with symbol $S_2^{(1)}$ in figure 2, and are usually metal equipment cabinets. Within the launch tube, the vehicle skin is also a secondary shield that separates the rocket vehicle circuits from the environment of the equipment room and launch tube.

The pertinent shield topology is illustrated in figure 3, where the left half of the diagram represents the equipment room and the right half represents the launch tube. The primary shield on the left side is compromised by the penetrating cables, while on the right side the primary shield is compromised by the leaky lid apertures. The divider between the left and right sides represents the wall separating the launch tube from the ground equipment room; this divider is compromised by the umbilical cable between the support equipment and the vehicle.

All sensitive circuits and components are presumed to be in the small-signal regions enclosed by the second level shields. That is, all small-signal processing circuits are housed in the ground support equipment cabinets (shield 2,2)). Less susceptible circuits (lighting, heating/air conditioning, power conditioning) may be compatible with the equipment room environment.

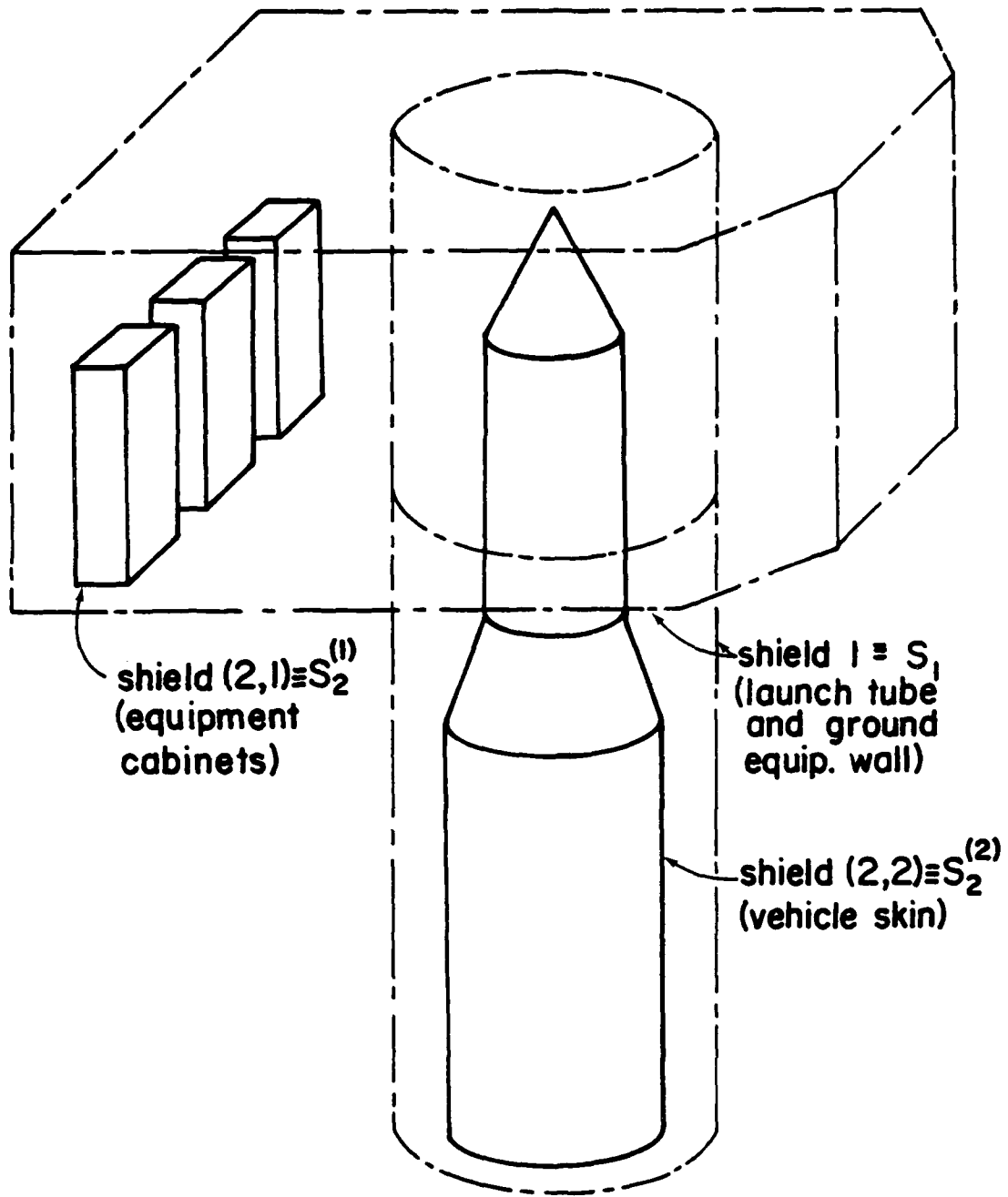

Figure 2. Identification of System Shields

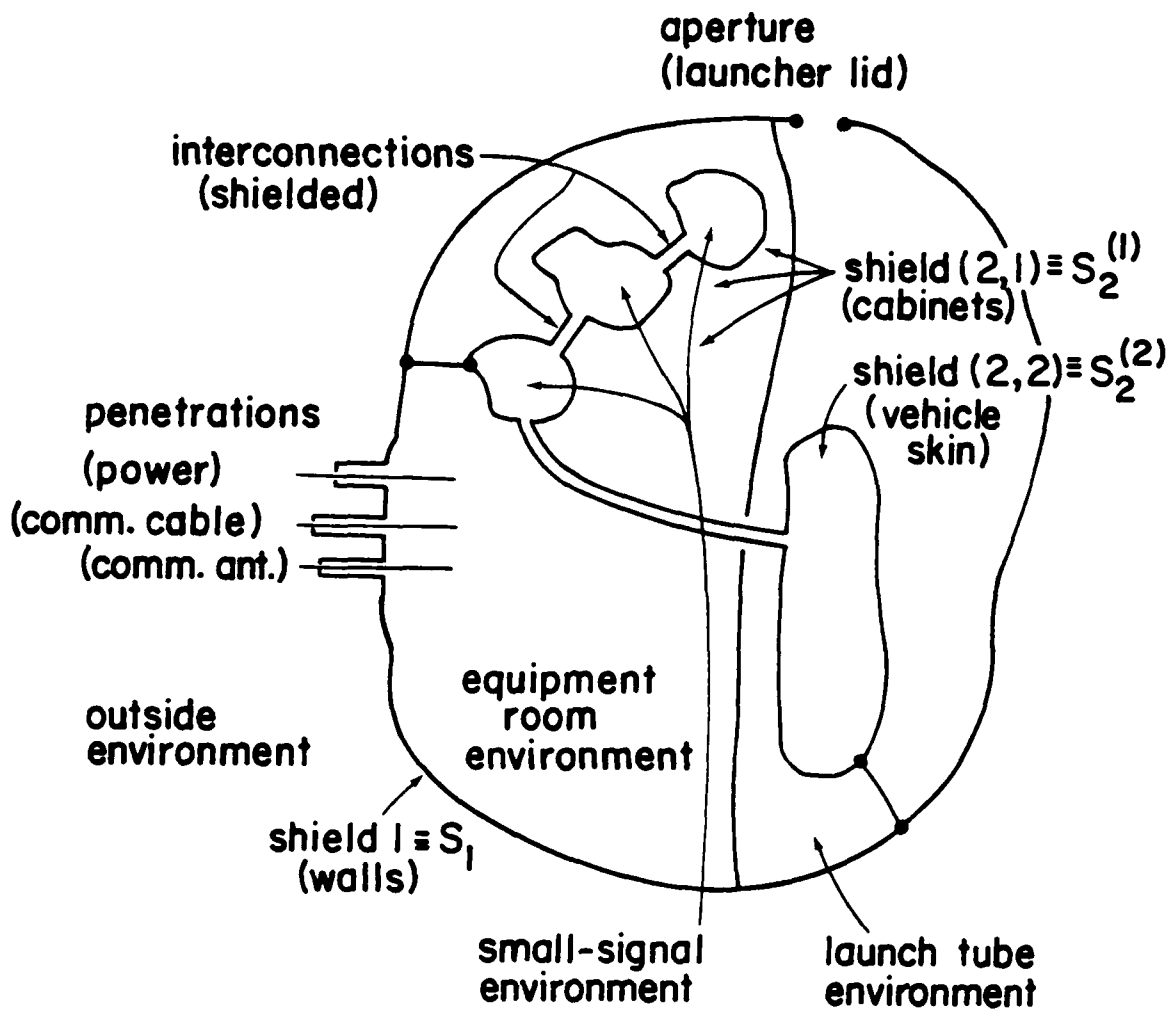

Figure 3. Shielding Topology

SECTION III
EXTERNAL INTERACTION

Four external interaction problems will be used in this example. They are:

- a.- The overhead power lines.
- b. The buried communication cable.
- c. An on-site antenna and feed cable.
- d. The external fields existing the apertures about the launch tube lid.

1. AC POWER

The elements of the power line problem are illustrated in figure 4(a). The exposed elements are a semi-infinite overhead conductor with a vertical down lead. These elements drive a shielded feeder that leads to the main distribution panel. At the main distribution panel, the power circuits branch out to the various system loads, one of which is the equipment within the primary shield. All circuits are assumed to be enclosed in tight metal conduit, so that between the feeder to the facility shield, negligible additional coupling to the power conductors occurs. Within the main distribution panel, the power conductors leave the conduit and are routed to circuit breaker terminals. This portion of the conductors has been represented by an inductance in figure 4(a); it could also be represented by a segment of transmission line whose characteristic impedance is larger than that of the conductors in the conduit.

Figure 4(b) illustrates the determination of the Norton equivalent source characteristic from the incident EMP and the exposed conductor geometry. The induced terminal current can be obtained from scattering theory or

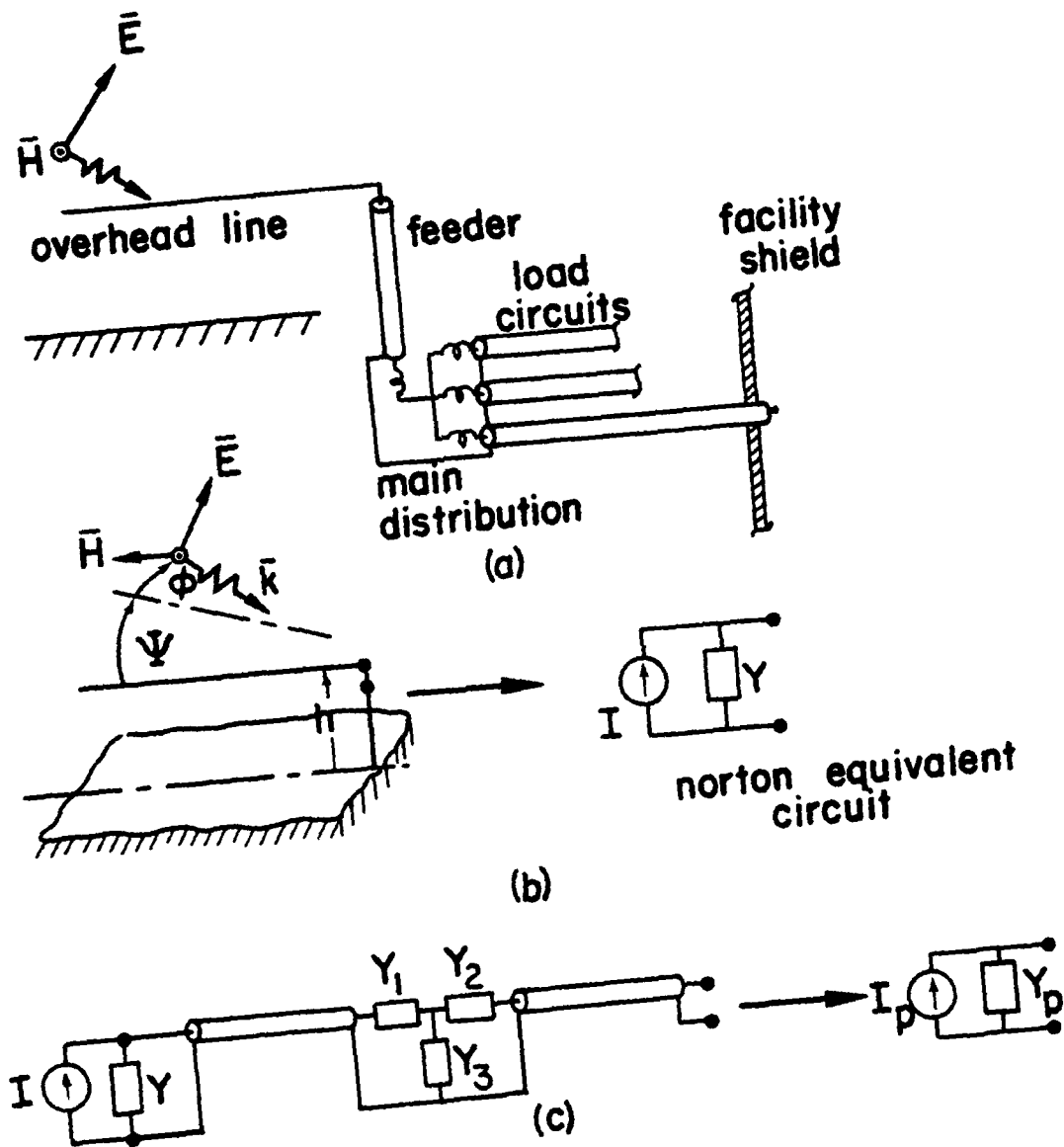

Figure 4. External Coupling and Propagation Through AC Power System
 (a) AC Power Circuits
 (b) Equivalent Source for Overhead Lines
 (c) Source Transferred to Facility Shield Penetration

approximated using transmission line theory. In either case, the short circuit current will depend on the incident EMP waveform and azimuth and elevation angles of incidence, and the current and admittance will both depend on the conductor size and height, and soil conductivity and permittivity.

The propagation of the induced current through the feeder, distribution panel, and essential load conduit is illustrated in figure 4(c). The stray inductances in the distribution panel and the other circuits in the support building (outside the primary shield) are represented by a Tee network in figure 4(c). Generally, the electrical wiring consists of several conductors in a conduit; thus the transmission lines shown in figure 4(a) and (c) are multiconductor transmission lines. As suggested in figure 4(c), the transmission-line problem is solved as a two-conductor line to obtain the common-mode Norton equivalent source (I_p, Y_p) at the point where the conduit penetrates the primary shield.

2. BURIED COMMUNICATION CABLE

The buried communication cable is assumed to be a shielded, multiconductor cable buried at a uniform, shallow depth in the soil. As illustrated in figure 5(a), the cable shield is in contact with the soil and is circumferentially connected to the primary shield where the cable enters the facility.

The external interaction problem for the buried cable may be separated into three parts: (1) determination of the ambient fields in the soil (figure 5(a)); (2) determination of the total current induced in the cable by these fields (figure 5(b)); and (3) determination of the common-mode internal conductor currents from the total current and shield properties (figure 5(c)). For common installations, the cable can be treated as though it extended to infinity (away from the facility) and the shield is terminated in a short

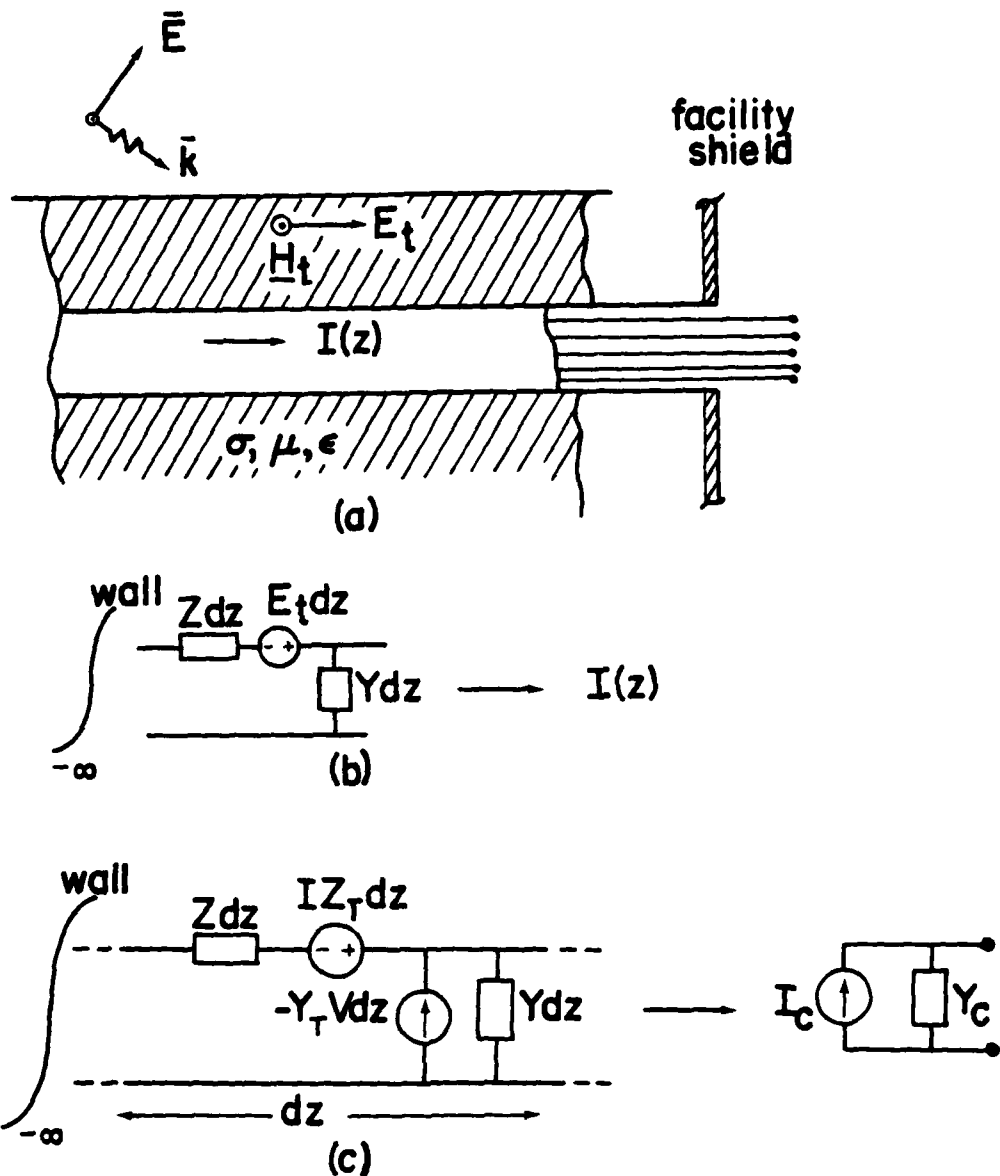

Figure 5. External Coupling and Propagation Through Shielded Underground Communication Cable

- (a) Underground Communication Cable
- (b) Bulk Current in Cable
- (c) Wire Current at Facility Shield Penetration

circuit at the facility shield. The cable shield may be composed of two or more shields; these are shorted together at the facility shield. The shields are usually continuous cylindrical shields (no apertures); thus only diffusion through the shields need be considered.

The final result of the external interaction analysis will be the common-mode Norton equivalent source characteristics (I_c, Y_c) representing the internal conductors at the point where they penetrate the facility shield.

3. COMMUNICATION ANTENNA AND FEED CABLE

The communication antenna and feed cable are illustrated in figure 6(a). In this simplified model, the external interaction elements consist of the antenna and its base or ground plane, and the coaxial cable between the antenna and the primary shield. In practice, the antenna system may also contain an antenna coupler (matching network) and preamplifier at the base of the antenna; these components are not included in the example. The coaxial cable between the antenna and the facility shield is assumed to be RF coaxial transmission line with a braided-wire shield. Thus, aperture penetration through the cable shield will contribute to the externally induced current in the cable.

The EMP-induced current in the feed cable will consist of two parts: that induced in the antenna and propagated through the cable (figure 6(b)), and that induced through the cable shield along its exposed length between the antenna and the facility shield (figure 6(c)). For the first part, the transient response of the antenna and its broad band input admittance must be determined. Simple transmission line theory is then used to transfer the antenna characteristics (I_d, Y_d) to the penetration point to obtain the Norton equivalent source (I'_a, Y_a) driving the internal cable.

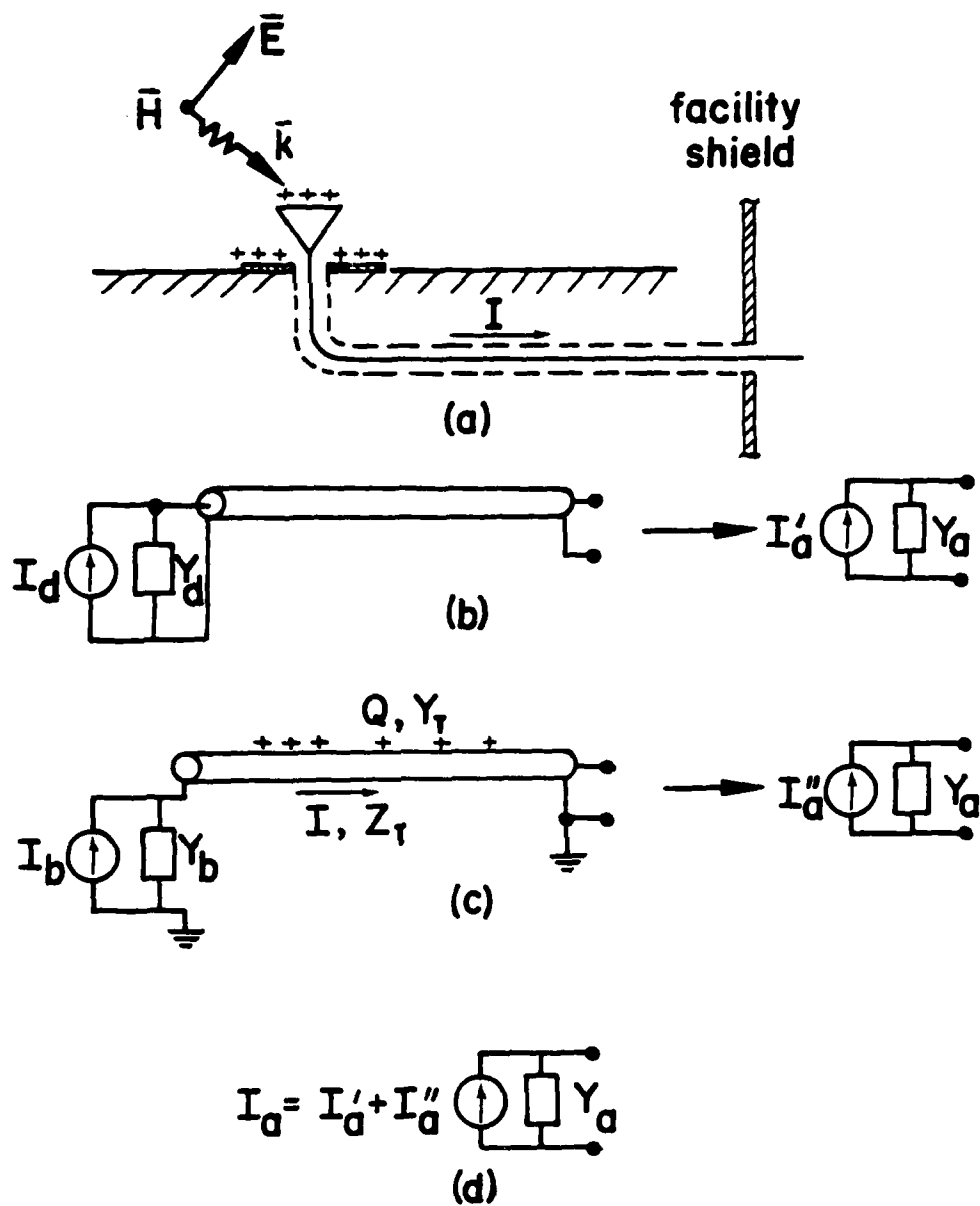

Figure 6. External Coupling and Propagation Through External Antennas and Feeds

- (a) Communication Antenna and Feed
- (b) Contribution of Antenna Element
- (c) Contribution of Antenna Base and Cable Current and Charge
- (d) Equivalent Source at Facility Shield Penetration

For the second part of the external interaction problem, the total current and charge induced in the finite length cable must be determined. This will include any current caused by interaction of the external fields with the antenna base (I_b, Y_b) as well as the distributed current induced by the fields along the cable. The total cable current and charge and the shield transfer characteristics will then be used to determine the Norton equivalent source (I_a'', Y_a) at the penetration point caused by cable current. (It will be assumed that the leakiness of the shield has a negligible effect on the source admittance Y_a). The resultant source (I_a, Y_a) at the penetration point is then obtained by superposition of the two sources (figure 6(d)).

4. LID EXCITATION

The aperture penetration problem associated with the launcher lid is illustrated in figure 7. An exact solution of the problem is very difficult because the apertures are at a discontinuity in the cylindrical surface. In an operational facility, the geometry is even more complicated because the lid makes a sliding contact with the top of the launch tube so that the aperture has depth as well as area. In addition, the crack between the lid and the tube may be partially filled with lubricants and RFI gasket material. For this example, however, we will assume a simple circumferential aperture divided into three segments by the lid/tube contact.

The external interaction problem consists of determining the surface fields (figure 8(a)) and the current density J flowing across the top surface of a metal cylinder immersed in the soil due to the incident EMP (figure 8(b)). A second mode of excitation can be postulated for longitudinal current flowing from the lid to the walls of the tube; this current will be driven by the vertical component of the electric field, whereas the current flowing across the top is driven by the horizontal component of the magnetic field.

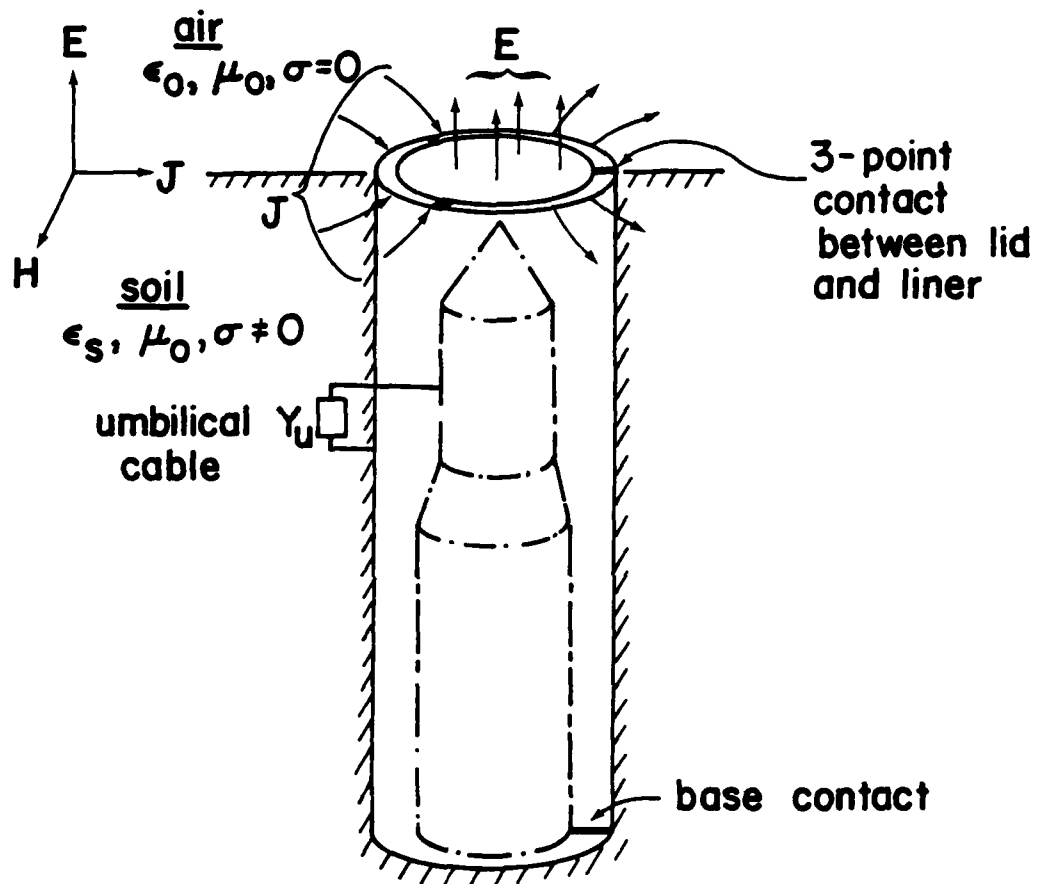
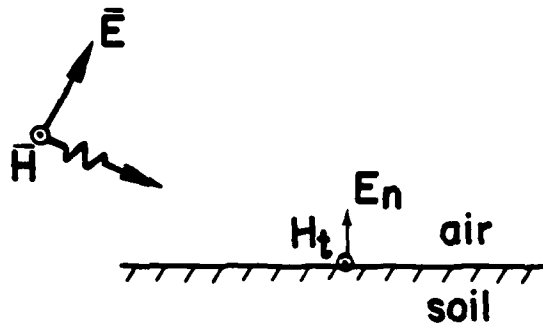
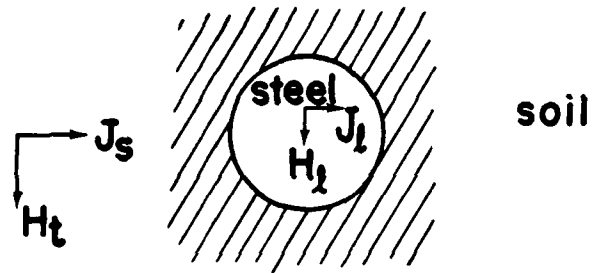

Figure 7. Aperture Coupling Configuration



(a) surface fields



(b) surface magnetic field at lid

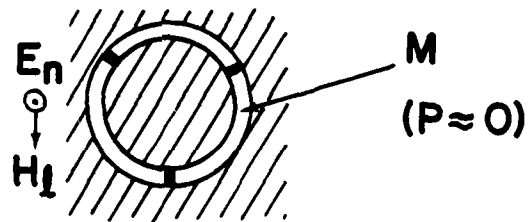

(c) polarizabilities of slots

Figure 8. External Coupling to Launcher Lid Apertures

The remainder of the external interaction problem is the calculation (or estimation) of the magnetic polarizability of the apertures (figure 8(c)). It will be assumed that the electric polarizability of the aperture is negligible in the practical case of a wide, low-impedance flange contact between the lid and the cylindrical launch tube.

SECTION IV

INTERNAL INTERACTION

The internal interaction problem is to determine the way the Norton equivalent sources and apertures excite the space and conductors inside the primary shield. Before analyzing the internal interaction problem, we must define the internal cable system. A simplified block diagram of the internal components of the system is illustrated in figure 9. This system typically consists of a control system that receives signals from the communication cable, the communication radio receiver, vehicle (and other subsystems), and sends status signals out through the communication cable and control signals to the vehicle through the umbilical cable. All the subsystems receive their operating power from the power conversion equipment. The power conversion equipment, in turn, operates from commercial ac power and supplies the dc, 400 Hz, and other forms of power required by the subsystems. The power conversion equipment may contain an "uninterruptible power system" as well as converters and inverters to provide the specified power requirements of the system.

In figure 9, each block may be considered an equipment cabinet, and each interconnecting line may be considered a shielded cable. The cables originating along the left side of the diagram are driven by the Norton equivalent source derived in the external interaction analysis. For the interconnecting cables inside the primary shield enclosing the ground equipment, it is assumed that the interference of concern is the current propagated along the cables, rather than the internal fields associated with cavity excitation in the equipment room. In the launch tube, however, the coaxial cavity excitation by the lid apertures is of interest. In the examples below, one internal cable

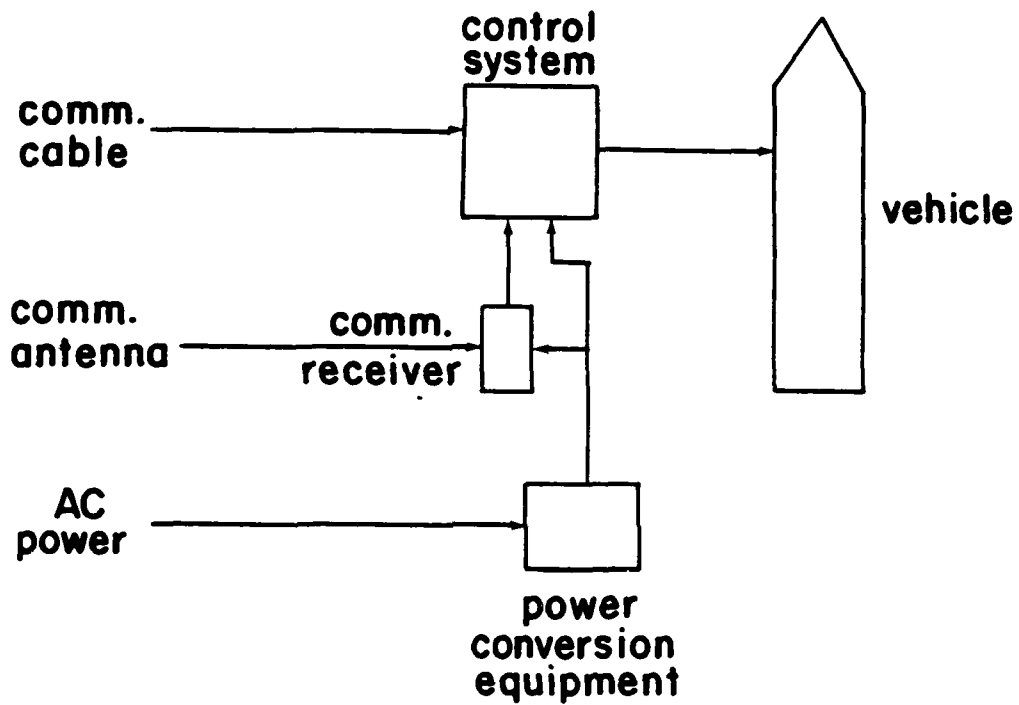

Figure 9. Simplified Block Diagram of Internal Components of Launcher System

system excited by the penetrating external cable will be examined, and the aperture excitation of the vehicle launch tube cavity will be examined.

1. INTERNAL POWER CABLES

The internal power system cables will be used to illustrate how the penetrating external currents are propagated through the internal cables to the subsystems and to the vehicle. The Norton equivalent source (I_p, Y_p) of figure 4(c) is the excitation source for the internal power cables. Current from this source is propagated along the cable in the conductor/shield mode as illustrated in figure 10(a). Part of the current incident on the power conversion equipment passes through the conversion circuits (T_p) and propagates to the other subsystems. In addition, part of the current incident on the control system may pass through these circuits (T_c) and propagate to the vehicle. In each case, the multiconductor cables are represented as two-conductor lines, and the terminating impedance and transfer function matrices are approximated by one and three terminal networks. Pass-through current to other cables associated with the subsystems is neglected except to the extent that it affects the terminating impedances (Z_r, Z_m) and the transfer functions (T_p, T_c) .

Another mechanism for interference propagation is illustrated in figure 10(b). Here, a leaky shield permits the TEM fields inside the shielded cable to induce current on the outside of the shield (I_s, V_s) . This current propagates along the cable shield to the equipment cabinets and cabinet grounding straps $(Z_{pg}, Z_{rg}, Z_{cg}, Z_{mg})$. Unless these grounding impedances are very small, sizable shield currents may reach the control and umbilical cables, where they may again penetrate the cable shields and induce current on the internal conductors and small-signal circuits. Because the power conversion circuits

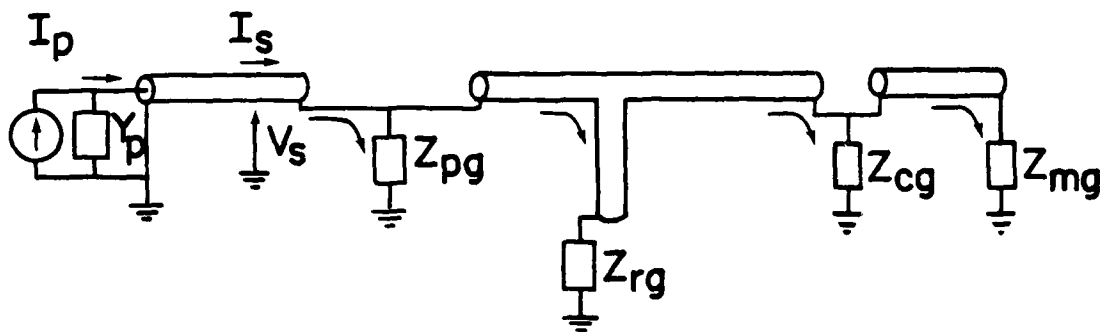
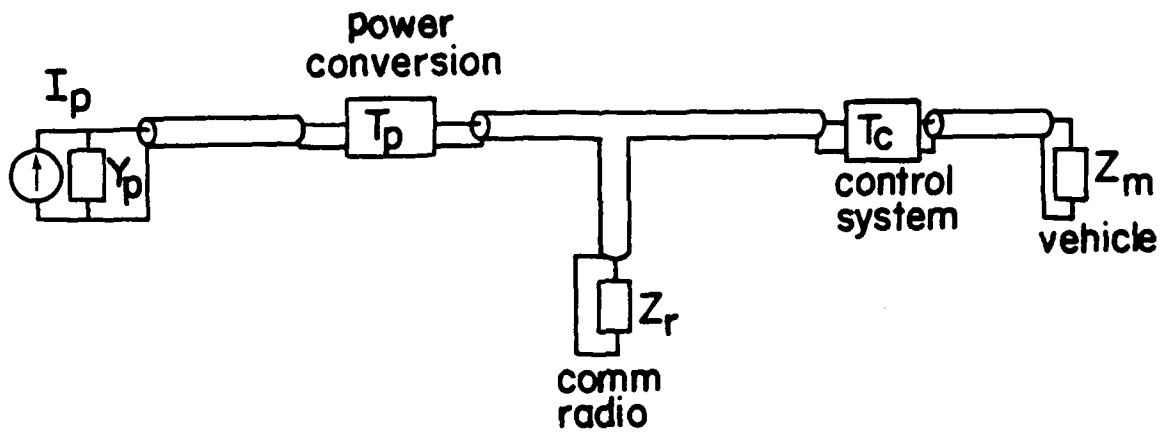

Figure 10. Propagation of Penetrating Power Current to Internal Circuits
 (a) Internal Propagation -- Conductor/Shield Mode
 (b) Shield Excitation by Internal Voltage and Current

often afford a high degree of isolation between the incoming 60 Hz conductors and the outgoing processed-power conductors, a interference propagation along the shield to the downstream equipment may be a significant mechanism. In addition, the current outside the shield interacts with the grounding impedances (Z_{pg}, Z_{rg} , etc.) to produce fluctuations in the cabinet potentials which may appear to internal circuits to be fluctuations in the potentials of conductors in other cables serving the cabinet. Furthermore, part of the current on the power cable shield may flow onto, say, the communication cable shield, or vice versa; the excitation of the umbilical cable through the control system cabinet is an example of this mechanism in figure 10(b).

Rigorous analysis of these propagation mechanisms is primarily an exercise in multiconductor and single conductor transmission line analysis. In practice, the major obstacle to such an analysis is the determination of the impedance and transfer function matrices, which are difficult to calculate accurately and time-consuming to measure. To simplify the analysis, the cables are represented as single conductor transmission lines, and only the common-mode currents on the internal conductors are determined. Representative terminal-to-ground impedances or input-terminal-to-output-terminal transfer functions are used to estimate the current delivered to terminal equipment and downstream equipment.

2. APERTURE EXCITATION OF LAUNCH TUBE

The internal interaction problem associated with the lid apertures is composed of two parts: that part which induces surface charge and current densities on the vehicle, and that part that gives the current induced in the umbilical cable. For this example, the charge and current distribution on the vehicle skin will be considered a final result; the effect of these on

circuits inside the vehicle may be obtained by the same techniques used for the rocket vehicle in flight. The current induced in the umbilical cable may propagate along the shield to other components and cables (as in the power cable example above), or it may penetrate the shield and propagate into the small-signal circuits in the vehicle or ground support equipment. This current may be derived from the fields in the coaxial cavity.

The first step in the analysis of the aperture-cavity problem is to calculate the fields induced in the coaxial cavity by the fields penetrating the apertures at the lid. From the solution of the aperture-excited cavity, the charge and current density on the vehicle can be determined as indicated in figure 11. In addition, the voltage between the vehicle and the launch tube at the umbilical location can be calculated.

From the open-circuit voltage and the short-circuit current (or the input admittance of the coaxial cavity) at the umbilical location, the Norton equivalent source driving the umbilical cable is determined (figure 12(a)). This source drives the umbilical cable shield that penetrates the equipment room (figure 12(b)), whose input admittance is obtained from transmission line theory (figure 12(c)). The charge and current on the umbilical cable due to aperture coupling through the lid are thus determined (figure 12(d)).

The charge and current distribution and the characteristics of the umbilical cable shield are then used to obtain the current in the umbilical cable conductor terminations (figure 12(e)). These currents may be superimposed on those derived for the penetration excited cables to obtain the total current in critical circuits in the control system and the vehicle guidance system.

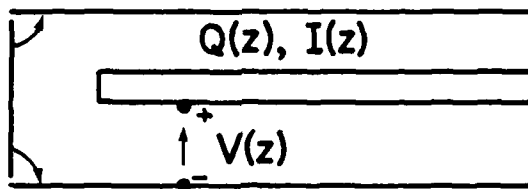

Figure 11. Aperture Coupling to Launcher/Vehicle Cavity

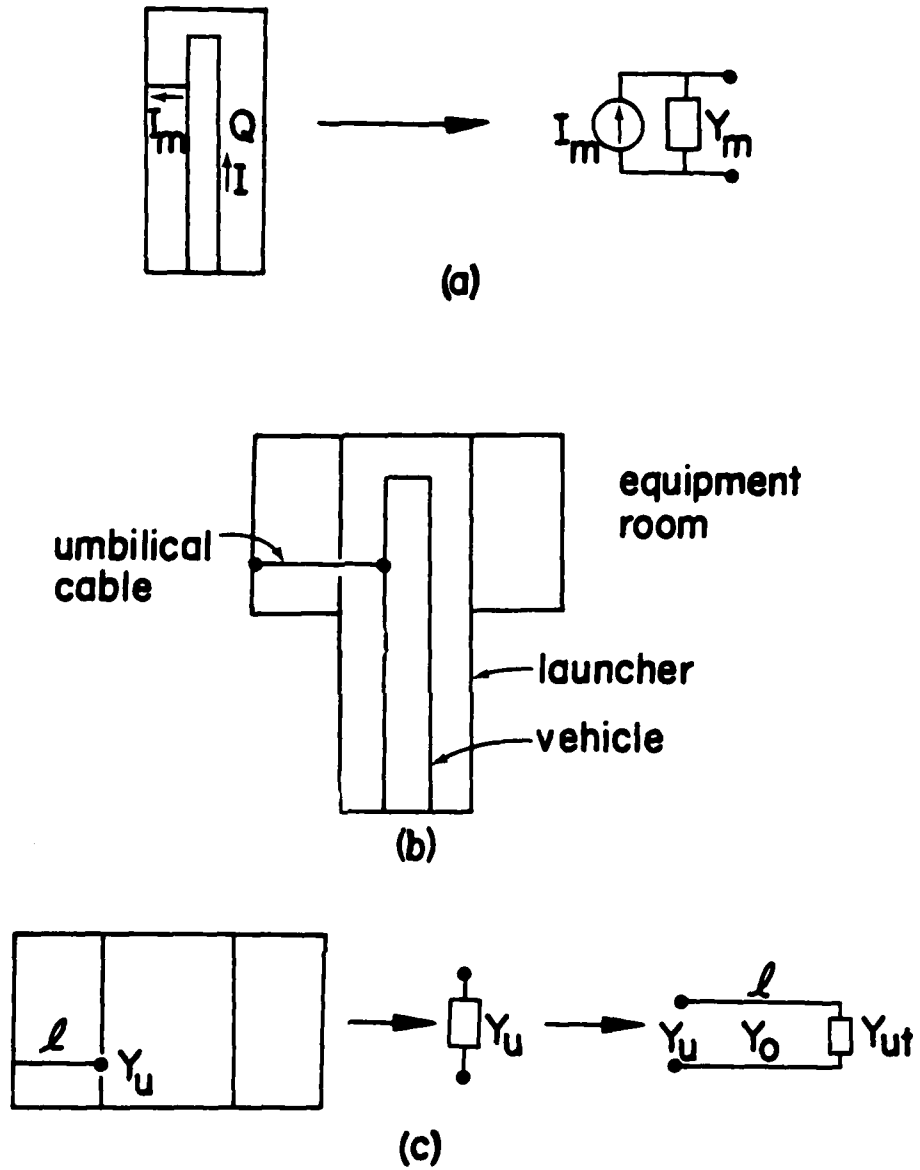

Figure 12. Current in Umbilical Cable Conductors
 (a) Norton Equivalent Circuit of Coaxial Cavity
 (b) Umbilical Cable Configuration
 (c) Umbilical Cable Input Admittance

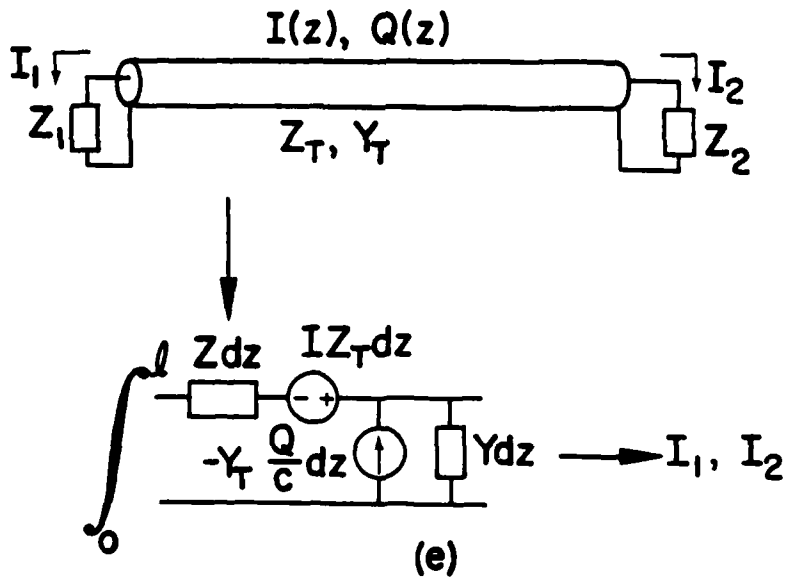
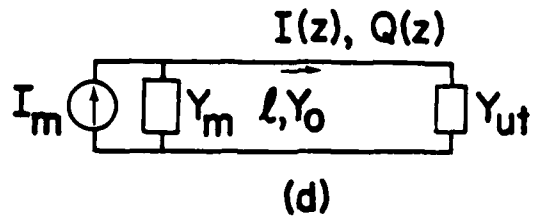

Figure 12. (Cont'd): (d) Current and Charge Distribution on Umbilical Cable
 (e) Current In Umbilical Cable Conductors