

AD-A103 195

NAVAL RESEARCH LAB WASHINGTON DC
STANDARD METHOD OF TEST FOR CONSTANT-LOAD-AMPLITUDE FATIGUE CRA--ETC(U)
AUG 81 T W CROOKER; F D BOGAR; G R YODER
NRL-MR-4594

F/G 20/11
CRA--ETC(U)

UNCLASSIFIED

NL

1 OF 1
AD-A
195 195



END

DATE

FILMED

9-81

DTIC

1570 (12)

**Standard Method of Test for Constant Load, Variable Stress
Fatigue Crack Growth Rates in Metallic Materials**

T. W. Cannon, F. D. Brown, and G. E. Miller

*Division of Materials Research,
National Science and Technology Division*

August 6, 1961

CONFIDENTIAL

AD A103195

FILE COPY

REPORT DOCUMENTATION PAGE		READ INSTRUCTIONS BEFORE COMPLETING FORM	
1. REPORT NUMBER NRL Memorandum Report 4594	2. GOVT ACCESSION NO. AD-A103 195	3. RECIPIENT'S CATALOG NUMBER	
4. TITLE (and Subtitle) STANDARD METHOD OF TEST FOR CONSTANT-LOAD-AMPLITUDE FATIGUE CRACK GROWTH RATES IN MARINE ENVIRONMENTS	5. TYPE OF REPORT & PERIOD COVERED Final report on one phase of a continuing NRL problem.		6. PERFORMING ORG. REPORT NUMBER
7. AUTHOR(s) T. W. Crooker, F. D. Bogar, and G. R. Yoder	8. CONTRACT OR GRANT NUMBER(s)		
9. PERFORMING ORGANIZATION NAME AND ADDRESS Naval Research Laboratory Washington, DC 20375	10. PROGRAM ELEMENT PROJECT, TASK AREA & WORK UNIT NUMBERS 62761N; SF61541501; 63-1052-0-1		
11. CONTROLLING OFFICE NAME AND ADDRESS Naval Sea Systems Command Washington, DC 20362	12. REPORT DATE August 6, 1981		13. NUMBER OF PAGES 25
14. MONITORING AGENCY NAME & ADDRESS (if different from Controlling Office)	15. SECURITY CLASS (of this report) UNCLASSIFIED		
	15a. DECLASSIFICATION DOWNGRADING SCHEDULE		
16. DISTRIBUTION STATEMENT (of this Report) Approved for public release; distribution unlimited.			
17. DISTRIBUTION STATEMENT (of the abstract entered in Block 20, if different from Report)			
18. SUPPLEMENTARY NOTES			
19. KEY WORDS (Continue on reverse side if necessary and identify by block number) Fatigue Test method Marine corrosion Fracture mechanics Crack growth			
20. ABSTRACT (Continue on reverse side if necessary and identify by block number) The determination of fatigue crack growth rates in marine environments is known to be influenced by numerous experimental factors. Therefore, it is necessary to formulate a standard method of test to assure uniformity of test results. This report describes recommended procedures for the measurement of fatigue crack growth rates for metallic materials tested in marine corrosion environments.			

CONTENTS

INTRODUCTION 1

SCOPE 2

APPLICABLE DOCUMENTS 2

SUMMARY OF METHODS 3

SIGNIFICANCE 4

DEFINITIONS 5

APPARATUS 7

SPECIMEN CONFIGURATION, SIZE, AND PREPARATION 7

PROCEDURE 8

CALCULATIONS AND INTERPRETATION OF RESULTS 13

REPORT 14

ACKNOWLEDGMENTS 15

REFERENCES 16

APPENDICES A-1

REFERENCES TO THE APPENDICES A-6

Acc 100

OF

✓

By

District of

Avail City codes

11 00 00

Specimen

A

STANDARD METHOD OF TEST FOR CONSTANT-LOAD-AMPLITUDE FATIGUE CRACK GROWTH RATES IN MARINE ENVIRONMENTS

T. W. Crooker, F. D. Bogar and G. R. Yoder

Mechanics of Materials Branch
Material Science and Technology Division
Naval Research Laboratory
Washington, DC 20375

INTRODUCTION

Modern naval applications of metallic materials in structures and machinery can involve conditions which cause corrosion fatigue crack growth to occur, namely cyclic stresses acting on points of geometric stress concentration in the presence of a marine corrosion environment. Crack growth caused by corrosion fatigue can pose a serious threat to the structural integrity of naval platforms and systems [1]. In recent years, naval ship designers have encountered an increasing number of applications where the possibility of corrosion fatigue crack growth requires consideration [2].

Linear elastic fracture mechanics provides a widely utilized basis for analyzing fatigue crack growth in metallic materials [3-6]. The basic test method procedures for constant-load-amplitude fatigue crack growth rate determination are found in ASTM E647-78T [7]. However, the presence of a corrosive environment is known to introduce numerous complicating factors, both in the laboratory determination of fatigue crack growth rates [8] and in the analysis of structural crack growth behavior [9-11].

Corrosion fatigue crack growth rates can vary widely in metallic materials as a function of mechanical, metallurgical and electrochemical variables. Therefore, it is essential that test results accurately reflect the effects of specific variables under study. Test methods must be chosen so as to neither accentuate nor suppress the phenomena under investigation. Only then can data be compared from one laboratory investigation to another on a valid basis, or serve as a valid basis for assessing structural behavior.

The development and application of a reliable Navy data base on corrosion fatigue crack growth rates in marine environments requires standard test methods. Experience has shown that, in the absence of common experimental procedures, interlaboratory variability amongst the data is sufficient to mask significant effects and cast doubt upon the basic premises of this technology. This test method document has been prepared to serve as an aid in enhancing the value of existing fracture mechanics fatigue crack growth technology for naval applications.

Manuscript submitted June 18, 1981.

1. SCOPE

1.1 This method covers the determination of constant-load-amplitude fatigue crack growth rates in metallic materials exposed to aqueous marine environments. Either compact type (CT) or wedge-opening-loaded (WOL) type specimens are recommended. Results are expressed in terms of fatigue crack growth rate (da/dN) as a function of crack-tip stress-intensity range (ΔK), where the parameter ΔK is defined by linear elastic fracture mechanics.

1.2 This test method is applicable to virtually all metallic materials used in naval applications, where such materials are subject to corrosion fatigue crack growth. Buckling considerations in the tension loading of CT and WOL specimens limit the minimum thickness of material which can be tested. The extent of crack-tip plasticity which develops during testing limits the minimum specimen width which may be utilized and/or the maximum crack depth which may be attained.

1.3 A range of specimen sizes with proportional planar dimensions is provided. Minimum permissible specimen planar dimensions will either be determined by material yield strength properties or by maximum loading considerations. Specimen thickness may be varied independently of planar dimensions.

1.4 Specimen configurations other than those contained in this method may be used, provided that well established stress-intensity calibrations are available.

2. APPLICABLE DOCUMENTS

2.1 CORROSION TESTING

2.1.1 G3-74, "Standard Recommended Practice for Conventions Applicable to Electrochemical Measurements in Corrosion Testing", in 1980 Annual Book of ASTM Standards, American Society for Testing and Materials, Philadelphia, 1980, Part 10, pp. 794-802

2.1.2 G5-78, "Standard Recommended Practice for Standard Reference Method for Making Potentiostatic and Potentiodynamic Anodic Polarization Measurements", *ibid.*, pp. 816-826

2.1.3 G15-79a, "Standard Definitions of Terms Relating to Corrosion and Corrosion Testing", *ibid.*, pp. 827-831

2.2 FATIGUE CRACK GROWTH RATE TESTING

2.2.1 E647-78T, "Tentative Test Method for Constant-Load-Amplitude Fatigue Crack Growth Rates Above 10^{-8} m/Cycle," in 1980 Annual Book of ASTM Standards, American Society for Testing and Materials, Philadelphia, 1980, Part 10, pp. 749-767

2.2.2 S. J. Hudak, Jr., A. Saxena, R. J. Bucci and R. C. Malcolm, "Development of Standard Methods of Testing and Analyzing Fatigue Crack Growth Rate Data," Technical Report AFML-TR-78-40, Air Force Materials Laboratory, Wright-Patterson Air Force Base, Ohio, May 1978

- 2.2.3 G. R. Yoder, L. A. Cooley and T. W. Crooker, "Procedures for Precision Measurement of Fatigue-Crack-Growth-Rate Using Crack-Opening-Displacement Techniques," in FATIGUE CRACK GROWTH MEASUREMENT AND DATA ANALYSIS, ASTM STP 738, Edited by S. J. Hudak, Jr. and R. J. Bucci, American Society for Testing and Materials, 1981, pp. 85-100

2.3 FRACTURE TESTING

- 2.3.1 E399-78a, "Standard Test Method for Plane-Strain Fracture Toughness of Metallic Materials," in 1980 Annual Book of ASTM Standards, American Society for Testing and Materials, Philadelphia, 1980, Part 10, pp. 580-601

- 2.3.2 E616-80, "Standard Terminology Relating to Fracture Testing," *ibid.*, pp. 714-721

2.4 MECHANICAL TESTING

- 2.4.1 E6-76, "Standard Definitions of Terms Relating to Methods of Mechanical Testing," in 1980 Annual Book of ASTM Standards, American Society for Testing and Materials, Philadelphia, 1980, Part 10, pp. 187-195

- 2.4.2 E8-79a, "Standard Methods of Tension Testing of Metallic Materials," *ibid.*, pp. 197-216

- 2.4.3 E11-61, "Standard Test Method for Young's Modulus at Room Temperature," *ibid.*, pp. 324-328

- 2.4.4 E467-76, "Standard Recommended Practice for Verification of Constant Amplitude Dynamic Loads in an Axial Load Fatigue Testing Machine," *ibid.*, pp. 620-624

2.5 STRESS CORROSION CRACKING TESTING

- 2.5.1 R. W. Judy, Jr. and R. J. Goode, "Standard Method of Test for Plane-Strain Stress-Corrosion-Cracking Resistance of Metallic Materials," NRL Report 7865, Naval Research Laboratory, Washington, D.C., March 17, 1975

2.6 WATER

- 2.6.1 D1129-78a, "Standard Definitions of Terms Relating to Water," in 1979 Annual Book of ASTM Standards, American Society for Testing and Materials, Philadelphia, 1979, Part 31, pp. 3-6

- 2.6.2 D1141-75, "Standard Specification for Substitute Ocean Water," *ibid.*, pp. 949-951

- 2.6.3 Standard Methods for Examination of Water and Wastewater, 14th Edition, American Public Health Association, Washington, D.C., 1975

3. SUMMARY OF METHOD

3.1 The method involves constant-load-amplitude cyclic loading of precracked CT or WOL specimens exposed to an aqueous marine environment. Periodic measurements of crack length are made throughout the duration of the test. The use of a crack-opening-displacement (COD) technique for crack length measurement is recom-

mended. Other crack length measurement methods may be used. Crack length data are gathered as a function of elapsed cycles. These data are analyzed numerically in conjunction with applied load to generate da/dN versus ΔK data. The parameter ΔK is calculated from well established linear elastic fracture mechanics expressions.

3.2 Cyclic loading parameters are controlled throughout the duration of the test. Procedures are followed to minimize transient effects in the da/dN versus ΔK data resulting from test interruptions.

3.3 The portion of the test specimen containing the fatigue crack is surrounded by an environmental chamber. Chemical and electrochemical parameters within the environmental chamber are monitored and may be under active control.

4. SIGNIFICANCE

4.1 Fatigue crack growth rate expressed as a function of crack-tip stress-intensity range, da/dN versus ΔK , characterizes a material's resistance to stable crack extension under cyclic loading and provides an analytical basis for assessing crack growth behavior in structural applications. Background information on the basic rationale for utilizing linear elastic fracture mechanics to analyze fatigue crack growth is given in references 3 through 6.

4.1.1 In inert or mildly aggressive environments, constant-load-amplitude fatigue crack growth rates are primarily a function of ΔK and the load ratio, $R = P_{min}/P_{max}$. However, in aqueous marine environments, da/dN can become a complex function of ΔK , R , cyclic frequency, load-versus-time waveform, electrochemical potential, temperature, pH, dissolved oxygen, and electrolyte species and concentration. Also, test specimens subjected to long term fatigue crack growth rate testing in marine environments are subject to various corrosive effects which influence da/dN versus ΔK data. Data on the various effects of long term corrosive reactions on metallic fatigue crack growth rate test specimens suggest that these effects can either retard or hasten crack growth rates. Generation of da/dN versus ΔK data on metallic materials in aqueous marine environments requires proper selection, monitoring and control of mechanical, chemical and electrochemical test variables.

4.1.2 In many instances, expressing da/dN as a function of ΔK provides a description of crack growth behavior that is independent of specimen planar size, specimen thickness, and crack geometry. This geometry-independent characteristic of da/dN versus ΔK data provides the basic rationale for utilizing fracture mechanics parameters in the analysis of fatigue crack growth. However, geometry-independent da/dN versus ΔK behavior has been shown to break down in at least three circumstances: (i) due to buckling effects in thin sheet materials, (ii) due to the onset of constraint-sensitive instability fracture conditions in the terminal portion of da/dN versus ΔK curve, and (iii) due to varying degrees of accessibility of the aqueous environment to the crack tip region as a function of the degree of crack opening under load. Although evidence of (iii) above is limited, it is a factor that should be considered in the interpretation of fatigue crack growth rate test results for marine environments.

4.2 This test method can serve the following purposes:

4.2.1 To characterize the fatigue crack growth resistance of metallic materials used in naval applications as a function of service related metallurgical, mechanical and corrosion variables.

4.2.2 To provide a source of engineering reference data from which assessments can be made of crack growth behavior in naval hardware components.

4.2.3 To provide an improved quantitative basis for dealing with anticipated fatigue crack growth phenomena within the framework of formalized contractual agreements for the design, procurement and maintenance of naval ship systems.

5. DEFINITIONS

5.1 corrosion potential, E - the potential of a corroding surface in an electrolyte relative to a reference electrode measured under freely corroding conditions.

5.1.1 reference electrode - the electrode against which the electrical potential of a specimen is measured.

5.1.2 potentiostat - an instrument for automatically maintaining an electrode in an electrolyte at a constant potential or controlled potentials with respect to a suitable reference electrode.

5.2 crack length, a [L] - the physical crack length used to determine the crack growth rate and the stress-intensity factor. For the CT and WOL specimens, a is measured from the reference line connecting the bearing points of load application (load line).

5.2.1 crack (mouth) opening displacement, COD[L] - the displacement at the crack mouth due to elastic deformation, measured by a clip gage spanning the crack at the specimen edge.

5.2.2 crack (mouth) opening displacement calibration, COD-calibration - a mathematical expression, based on experimental or analytical results, that relates the crack (mouth) opening displacement to load, crack length, specimen thickness and elastic modulus for a specific specimen planar geometry.

5.3 cycle - one complete sequence of values of applied load that is repeated periodically in fatigue. The symbol N represents the number of elapsed cycles.

5.3.1 maximum load, P_{\max} [F] - the greatest algebraic value of applied load in a fatigue cycle. Tensile loads are considered positive and compressive loads negative.

5.3.2 minimum load, P_{\min} [F] - the least algebraic value of applied load in a fatigue cycle.

5.3.3 load range, ΔP [F] - the algebraic difference between the maximum and minimum loads in a fatigue cycle.

5.3.4 load ratio (also called stress ratio), R - the algebraic ratio of the minimum to maximum load in a fatigue cycle, $R = P_{\min}/P_{\max}$.

5.3.5 frequency [T^{-1}] - the number of total elapsed cycles in a given period of time.

5.3.6 waveform - the characteristic shape of a load versus time relationship.

5.3.7 rise time [T] - the elapsed time in a cycle during which the load increases from P_{\min} to P_{\max} .

5.3.8 hold time [T] - the elapsed time in a cycle during which the load remains constant, usually this occurs at P_{\max} or P_{\min} .

5.4 environment - the aqueous solution that surrounds a test specimen.

5.4.1 marine - pertaining to seawater.

5.4.2 environmental chamber - the container of aqueous solution surrounding a test specimen.

5.4.3 environment volume [L^3] - the total volume of aqueous solution immediately surrounding the test specimen, plus that contained in a circulating reservoir system if used.

5.4.4 environmental chamber volume [L^3] - the volume of aqueous solution contained in the environmental chamber when the test specimen is in place.

5.4.5 circulation rate [L^3T^{-1}] - the rate of aqueous solution flow through the environmental chamber.

5.5 fatigue crack growth rate, da/dN [LT^{-1}] - average increment of crack extension per cycle of loading.

5.6 seawater - an aqueous solution intended to exhibit the general characteristics of natural seawater for test purposes.

5.6.1 natural seawater - seawater obtained from an ocean source.

5.6.2 substitute ocean water - a specific solution for marine environment testing as specified in 2.6.2.

5.6.3 saline solution - a solution of sodium chloride in distilled water. For marine environment tests the electrolyte concentration is usually 3.5 weight-percent.

5.7 stress-corrosion cracking, SCC - crack extension caused by the simultaneous action of a sustained tensile load and the presence of a marine environment.

5.7.1 stress-corrosion cracking threshold, $K_{I,SCC}$ [$FL^{-3/2}$] - a level of sustained loading, as defined by linear elastic fracture mechanics, below which SCC does not occur in a specified combination of material and environment. See 2.5.1.

5.8 stress-intensity factor, K [$FL^{-3/2}$] - the magnitude of the crack-tip stress field in a linear-elastic material. In this method, Mode I (opening mode) crack surface displacement is assumed.

5.8.1 stress-intensity calibration, K-calibration - a mathematical expression, based on experimental or analytical results, that relates the stress-intensity factor to load, crack length and specimen thickness for a specific specimen planar geometry.

5.8.2 maximum stress intensity, K_{\max} [$FL^{-3/2}$] - the maximum value of the stress-intensity factor in a fatigue cycle, corresponding to P_{\max} .

5.8.3 minimum stress intensity, K_{\min} [$FL^{-3/2}$] - the minimum value of the stress-intensity factor in a fatigue cycle, corresponding to P_{\min} .

5.8.4 stress-intensity range, ΔK [$FL^{-3/2}$] - the maximum variation in the values of the stress-intensity factor in a fatigue cycle, $\Delta K = K_{\max} - K_{\min}$.

6. APPARATUS

6.1 Grips and Fixtures for CT and WOL Specimens - A conventional fracture-mechanics-type clevis and pin grip assembly is used. Details of the recommended grip assembly are provided in 2.2.1. This specimen and loading arrangement is to be used for tension-tension ($R > 0$) loading only. The grip assembly may be subjected to corrosive conditions because of the proximity of a marine environment, therefore the use of protective coatings on the grips is desirable. The use of a protective lubricant coating on all pin and clevis bearing surfaces is recommended to minimize friction and corrosion. Care should be exercised to prevent contamination of the test environment by coating or lubricant materials because corrosion processes can be inhibited or accelerated by small amounts of seemingly innocuous materials.

6.2 Displacement Gage - A conventional fracture mechanics type COD clip gage is used. Details of the recommended gage design and methods for mounting the gage on the specimen are provided in 2.3.1. It is recommended that signals from the COD gage be recorded on a suitable digital voltmeter. It is also recommended that calibration of the COD gage be performed using a knife-edge micrometer.

6.3 Environmental Chamber and Circulation System - The environmental chamber shall enclose the entire portion of the test specimen over which crack extension occurs. A circulation system is recommended to provide replenishment and aeration of the test solution. Non-metallic materials are required for the entire environmental chamber and circulation system. The environmental chamber shall be designed so as to prevent galvanic contact between test specimen and grip assembly. The use of a test frame configuration featuring a horizontal load actuator position is desirable for eliminating contact between grips and test solution. The environmental chamber shall be of sufficient size, and inlet and outlet locations shall be chosen, to assure a flow of test solution around the portion of the test specimen where crack extension occurs. The circulation system shall provide a flow rate capacity sufficient to replace the environmental chamber volume not less often than once per minute. The circulation system shall provide for continuous aeration and filtering of the test solution.

7. SPECIMEN CONFIGURATION, SIZE, AND PREPARATION

7.1 Standard Specimens - The geometries of standard CT and WOL specimens are given in Fig. 1. Dimensional and precracking details for both specimens are given in 2.2.1.

7.2 Specimen Size - For both specimens, the thickness, B , and width, W , may be varied independently within the following limits, which are based on specimen buckling, through-thickness crack curvature and uncracked ligament, $W-a$, considerations:

7.2.1 It is recommended that specimen thickness be within the range $W/20 \leq B \leq W/2$. For specimens where $B > W/4$, a through-thickness crack curvature correction may be required as specified in 2.2.1, unless the crack length measurement technique being employed has the capability to inherently average the effects of crack front curvature.

7.2.2 In order that specimen behavior remains predominantly linear-elastic under all test loads, it is recommended that the minimum uncracked ligament size not exceed the following:

$$W-a > \frac{4}{\pi} (K_{\max} / \sigma_{ys})^2$$

where σ_{ys} is the 0.2% offset yield strength of the test material as specified in 2.4.2.

7.2.3 The above criterion for $W-a$ can be restrictive for materials of low yield strength. In such cases, an alternate criterion based on flow stress, σ_f , can be utilized as follows:

$$W-a \geq \frac{4}{\pi} (K_{\max} / \sigma_f)^2$$

where σ_f is defined as the algebraic mean of the yield strength and tensile strength of the test material as determined by 2.4.2. However, it is recommended that all data which exceed the minimum uncracked ligament criterion in 7.2.2 be called out in the report.

7.3 Specimen Preparation - Specimen preparation specifications shall meet the recommendations and requirements of 2.2.1.

8. PROCEDURE

8.1 Number of Tests - It is recommended that replicate tests or separate tests which include overlapping regions of da/dN versus ΔK data be conducted.

8.2 Specimen Machining and Precracking - Specimens shall be machined to the dimensions shown in Fig. 1. Applicable detail dimensions and tolerances shall be per the requirements of 2.2.1. Precracking shall be conducted in accordance with the procedures described in 2.2.1. Preliminary precracking may be conducted in an ambient laboratory air environment using a cyclic frequency and waveform which differ from the test conditions. The final increment of precracking consisting of not less than 1.0mm (0.04 in.), shall be conducted in the marine environment under full test conditions.

8.3 Test Equipment - The equipment for fatigue testing shall provide stable control and/or precision measurement of the following test parameters.

8.3.1 Loads shall be measured by means of a load cell. Closed-loop control via load cell feedback is recommended. Verification of loads shall be conducted in accordance with 2.4.4. ΔP and P_{\max} shall be controlled to an accuracy of $\pm 2\%$ throughout the test.

8.3.2 Elapsed cycles shall be counted by means of an accurate digital device.

8.3.3 Frequency and waveform shall be controlled throughout the test. Use of an electronic function generator is recommended.

8.3.4 Digital instrumentation for COD measurement shall be calibrated to an

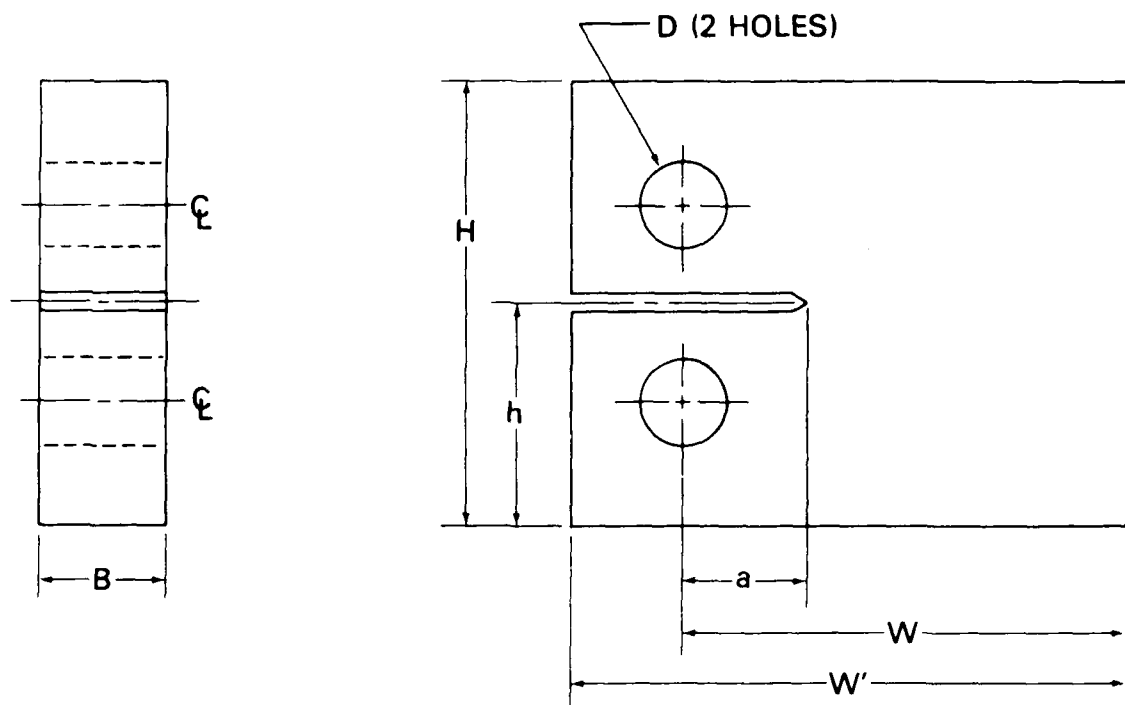

	CT	WOL
W	$\geq 25 \text{ mm (1.0 in.)}$	$\geq 25 \text{ mm (1.0 in.)}$
W'	$1.25 W$	$1.25 W$
a	$\geq 0.20 W$	$\geq 0.20 W$
h	$0.60 W$	$0.486 W$
H	$1.20 W$	$0.972 W$
D	$0.25 W$	$0.196 W$
B	$\frac{W}{20} \leq B \leq \frac{W}{2}$	$\frac{W}{20} \leq B \leq \frac{W}{2}$

Fig. 1 — Standard compact type (CT) and wedge-opening-loaded (WOL) type test specimens

accuracy of $\pm 1\%$ of range. It is recommended that this instrumentation be recalibrated at regular periodic intervals throughout the duration of testing.

8.4 General Test Procedure - Testing shall be conducted in a manner which seeks to eliminate or minimize transient and/or time-dependent effects on da/dN versus ΔK data.

8.4.1 It is recommended that specimens undergoing fatigue testing remain immersed in the test solution during brief periods of test interruption. If specimens are removed from the test solution for more than a brief period, fatigue data gathering shall not resume until the crack has extended by an increment of not less than 1.0mm (0.04 in.) under test conditions.

8.4.2 Specimens shall be visually examined periodically during the course of testing for evidence of corrosive attack. Corrosion product accumulation which may inhibit access of the test solution to the crack-tip region may be removed. The crack-tip region of the specimen surface may also be cleaned periodically to aid in visual observation of crack length and/or crack-tip morphology.

8.4.3 Fatigue testing may be performed under constant load amplitude, such that ΔP and P_{max} remain constant throughout the duration of the test, or by step-loading, such that ΔP_{max} and P_{max} are increased by small increments at periodic intervals of Δa . An example step-loading procedure is outlined in 2.2.3. When step-loading procedures are employed, ΔP_{max} increments shall not exceed 10% and Δa increments between load steps shall not be less than minimum Δa increments for crack length measurement specified in 8.5. Testing to obtain data in the lower region of da/dN versus ΔK may require the use of loading-shedding procedures as outlined in 2.2.2.

8.4.4 The presence of a marine environment may cause numerous environmentally-induced phenomena to occur in the course of fatigue crack growth rate testing of metallic materials. Some common examples are transient changes in da/dN versus ΔK data in response to changes or interruptions in cyclic loading [12-14], crack growth acceleration, crack arrest, crack branching, crack-front curvature or irregularity, out-of-plane cracking or corrosion product build-up within cracks. It is necessary to carefully monitor tests for evidence of these types of environmentally-induced phenomena which may affect steady state da/dN versus ΔK data.

8.4.5 Steady state fatigue crack growth rates in marine environments can be strongly affected by cyclic waveform and/or cyclic frequency [15-18]. Knowledge of these effects can be an important consideration in selecting test parameters. It is especially important to note that certain frequencies and/or waveforms can act to suppress the influence of marine environments on fatigue crack growth in metallic materials. These effects generally relate to the rise time of the loading cycle. For steels and high-strength aluminium alloys, crack growth rates in marine environments tend to vary inversely with the rise time [15-17]. However, exceptions to this trend have been observed in high-strength titanium alloys under cyclic loading conditions where $K_{max} < K_{Isc}$ [18].

8.4.6 Knowledge of the stress-corrosion cracking (SCC) threshold for the material/environment/electrochemical potential combination being tested is an important secondary consideration for fatigue crack growth rate testing in marine environments. The SCC threshold is defined by the linear elastic fracture mechanics parameter K_{Isc} [19], in accordance with the provisions of 2.5.1. If SCC is superimposed on fatigue

crack growth (K_{max} , K_{Isc}), SCC-related phenomena may occur which affect fatigue crack growth behavior and its measurement. Examples of such phenomena include crack extension under sustained loading at or near P_{max} which may occur in connection with crack length measurement procedures, or reversals of frequency and/or waveform effects which may occur as the K_{max} value approaches or exceeds K_{Isc} [18].

8.5 Crack Length Measurement - Crack length measurements are to be made as a function of elapsed cycles. A crack (mouth) opening displacement (COD) technique is recommended as the primary method of crack length measurement. Electrical potential techniques may also be employed [20]. However, caution is advised in applying electrical potential techniques to specimens immersed in an electrolytic solution due to possible electrochemical interaction effects. Optical observation of the crack-tip is recommended as an auxiliary method of crack length measurement and as a means of monitoring crack morphology, specifically crack branching or out-of-plane cracking which may render the test invalid. Crack length measurement techniques shall be capable of resolving crack extension increments of 0.10 mm (0.004 in.), or 0.002 W, whichever is greater, as required in 2.2.1.

8.5.1 Crack length can be calculated from COD using the following expression [21]:

$$a/W = C_0 + C_1 (U_x) + C_2 (U_x)^2 + C_3 (U_x)^3 + C_4 (U_x)^4 + C_5 (U_x)^5$$

where a/W = normalized crack length and

$$U_x = \frac{1}{\left[\frac{BE(COD)}{P} \right]^{1/2} + 1}$$

B = specimen thickness and E=Young's Modulus. Constants for the COD-calibration expression are given below:

Specimen	C_0	C_1	C_2	C_3	C_4	C_5
CT	1.0010	-4.6695	18.460	-236.82	1214.9	-2143.6
WOL	1.0021	-4.9472	35.749	-649.85	4110.9	-8410.8

8.5.2 An example of procedures for measurement of fatigue crack growth rate using COD techniques is given in 2.2.3. It is recommended that Young's Modulus be determined from actual test material using procedures described in 2.4.3., or alternatively, the COD measurements obtained from the precracked CT or WOL specimens. If the COD measurement is used for this purpose, it is necessary to make a simultaneous measurement of actual crack length by an independent method, usually by optical means at the specimen face (using, as necessary, a crack front curvature correction as described in section 9.1 of document 2.2.1). Then E can be obtained from the following expressions [16]: For the CT specimen,

$$\frac{EB(COD)}{P} = \left(1 + \frac{0.25}{a/W} \right) \left(\frac{1 + a/W}{1 - a/W} \right)^2 \left[1.61369 + 12.6778 (a/W) - 14.2311 (a/W)^2 - 16.6102 (a/W)^3 + 35.0499 (a/W)^4 - 14.4943 (a/W)^5 \right]$$

and for the WOL specimen,

$$\frac{EB(COD)}{P} = \left(1 + \frac{0.2549}{a/W}\right) \left(\frac{1 + a/W}{1 - a/W}\right)^2 \left[4.3838 - 37.588 (a/W) + 359.68 (a/W)^2 - 1319.5 (a/W)^3 + 2506.8 (a/W)^4 - 2577.0 (a/W)^5 + 1203.5 (a/W)^6 - 136.40 (a/W)^8\right] \quad [\text{sic}]$$

Values of E should always be determined experimentally using one of the above methods. Under no circumstances should a nominal value of E be selected from generic properties data commonly available in handbook sources (e.g., this is especially unsatisfactory for titanium alloys where E can vary by more than 15 percent due to heat treatment alone).

8.5.3 It is recommended that testing be interrupted as infrequently and as briefly as possible. When tests are interrupted for crack length measurement, a static load may be applied to the specimen to obtain P versus COD from which crack length may be calculated. Caution is advised to assure that such static loads do not exceed the P_{\max} value used for fatigue testing, and that the corresponding K_{\max} values do not cause static-load crack extension ($K_{\max} < K_{Isc}$).

8.5.4 The following criterion regarding crack length measurement intervals is recommended:

$$0.25 \text{ mm (0.01 in.)} < a < 2.5 \text{ mm (0.10 in.)}$$

8.5.5 The following criteria regarding out-of-plane cracking and asymmetric through-thickness cracking are recommended, as per 2.2.1:

8.5.5.1 If the crack path, as observed on either face of the specimen, departs from the plane of symmetry of the specimen by more than ± 5 degrees, the data are invalid. If this criterion is exceeded, termination of the test is recommended.

8.5.5.2 If the two crack lengths, as observed on each face of the specimen, differ by more than 0.025 W or 0.25 B, whichever is less, the data are invalid. However, testing may be continued in an effort to regain through-thickness crack symmetry.

8.6 Environment Monitoring and Control - Environmental parameters can strongly influence the results of fatigue crack growth rate tests conducted in marine environments. Therefore, environmental monitoring and control is recommended.

8.6.1 It is recommended that the test solution be selected from among the following: natural seawater, substitute ocean water as specified in 2.6.2, or aqueous 3.5% sodium chloride. However, note that these three environments may produce differing results and should not be regarded as identical for test purposes [22]. For tests which involve the use of a quiescent environment, it is recommended that the test solution be emptied and replenished not less often than once each 24 hr. testing period. For tests which involve the use of a closed-loop, recirculating flowing environment, it is recommended that the test solution be emptied and replenished not less often than weekly.

8.6.2 Measurements shall be made and recorded of solution temperature and specimen corrosion potential not less often than once each 8 hr. testing period. Potential measurements shall be made in accordance with conventions and procedures

set forth in 2.1.1 and 2.1.2. It is further recommended that measurements be made and recorded of pH, conductivity and dissolved oxygen at similar intervals. Procedures for these measurements are contained in 2.6.3. For tests conducted in a fresh natural seawater environment, seawater temperature can vary widely with climatic conditions. Therefore, it is recommended that the temperature of fresh natural seawater passing through the test specimen environmental chamber in a single-pass mode be controlled at $20^{\circ} \pm 1^{\circ}\text{C}$. For tests involving quiescent or recirculating environments conducted at normal ambient laboratory temperatures, control of environment temperature is also recommended.

8.6.3 For tests which involve maintaining the specimen at a controlled corrosion potential, use of a potentiostat is recommended rather than the use of sacrificial anodes.

9. CALCULATIONS AND INTERPRETATION OF RESULTS

9.1 Crack Curvature Correction - Some degree of crack front curvature of a tunneling nature is likely to occur in fatigue crack growth rate testing of CT or WOL specimens. The COD crack length measurement technique described in Section 8.5 will inherently average moderate degrees of crack front curvature which commonly occur in this type of testing. However, it is recommended that test specimens be tension-loaded to fracture after fatigue testing, and that the fatigue surfaces be visually examined for evidence of crack front curvature. If there is visual evidence of a significant degree of crack front curvature at any crack depth, crack length correction procedures detailed in 2.2.1 should be applied to the test data. However, if the crack front curvature correction results in a calculated stress-intensity correction greater than 10 percent, the test is invalid.

9.2 Determination of Crack Growth Rate - Crack growth rate data are calculated from crack length versus elapsed cycles data. Detailed procedures for calculating da/dN are included in 2.2.1. Additional procedures for calculating da/dN from COD measurements of crack length are described in 2.2.3.

9.3 Determination of Stress-Intensity Range - It is recommended that fatigue-crack growth rate data be restricted to the following span of crack lengths in both the CT and WOL specimens:

$$0.2 \leq a/W \leq 0.8$$

9.3.1 For the CT specimen, ΔK can be calculated from the following expression [23]:

$$\Delta K = \frac{\Delta P}{B\sqrt{W}} \frac{(2 + a/W)}{(1 - a/W)^{3/2}} [0.886 + 4.64 (a/W) - 13.32 (a/W)^2 + 14.72 (a/W)^3 - 5.6 (a/W)^4]$$

9.3.2 For the WOL specimen, ΔK can be calculated from the following expression [21]:

$$\Delta K = \frac{\Delta P}{B\sqrt{W}} \frac{(2 + a/W)}{(1 - a/W)^{3/2}} [0.8072 + 8.858 (a/W) - 30.23 (a/W)^2 + 41.088 (a/W)^3 - 24.15 (a/W)^4 + 4.951 (a/W)^5]$$

10. REPORT

10.1 The report shall include the following information:

10.1.1 Specimen type and principal dimensions, including thickness and width.

10.1.2 Descriptions of the test machine, crack length measurement equipment, environmental chamber, and all equipment used for environmental monitoring and/or control.

10.1.3 Description of the test material, including all relevant chemical, metallurgical and mechanical information available, including crack plane orientation as defined in 2.3.1.

10.1.4 Details of the precracking procedure as required in 2.2.1.

10.1.5 Details of the test loading are as follows: constant-load-amplitude throughout the duration of the test, load-shedding, or step-loading. If load-shedding or step-loading are used, ΔP_{\max} and Δa increments shall be stated. The report shall also include ΔP , R , cyclic frequency and cyclic waveform information.

10.1.6 Environmental variables shall be reported as follows: bulk solution chemistry composition and details of application. Procedures for environmental monitoring and control shall be described. Environmental monitoring data for such parameters as pH, potential or temperature shall be expressed in terms of the normal daily range experienced throughout the duration of the test. Relevant trends or transients in environmental parameter data shall be reported.

10.1.7 Analysis methods for converting COD measurements to a , and a versus N data to da/dN data shall be described.

10.1.8 Analysis methods for calculating ΔK values shall be described.

10.1.9 da/dN versus ΔK data shall be plotted on log-log coordinates. A separate tabulation of da/dN and ΔK data is recommended. It is also recommended that all data which exceed the minimum uncracked ligament criterion in 7.2.2 be so identified. All da/dN versus ΔK data for which $K_{\max} > K_{Isc}$ should be so identified. If the value of K_{Isc} is unknown, it should be so stated.

10.1.10 It is important to maintain a test log which records all test interruptions or load changes in terms of elapsed cycles, crack length and time. All data shall be scrutinized for transients and anomalies. All anomalous behavior shall be reported and described in relation to recorded test events.

ACKNOWLEDGMENTS

This test method has been developed under Naval Sea Systems Command sponsorship. W. H. Cullen, E. J. Czyryca, J. P. Gudas and M. G. Vassilaros have each provided valuable assistance leading to the preparation of this test method.

Portions of this test method have been reprinted or adapted, with permission, from the Annual Book of ASTM Standards. Copyright American Society for Testing and Materials, 1916 Race Street, Philadelphia, PA 19103.

REFERENCES

1. P. M. Palermo, "Structural Integrity Procedures for Naval Ships," in STRUCTURAL INTEGRITY TECHNOLOGY, Edited by J. P. Gallagher and T. W. Crooker, ASME Book No. H00144, American Society of Mechanical Engineers, New York, 1979, pp. 71-81
2. R. W. Judy, Jr., T. W. Crooker, J. E. Beach, J. A. Hauser, and J. A. Corrado, "Review of Fracture Control Technology in the Navy," NRL Memorandum Report 4170, Naval Research Laboratory, Washington, D. C., February 12, 1980
3. T. W. Crooker, "Fracture Mechanics Fatigue Design," *Mechanical Engineering*, Vol. 99, No. 6, June 1977, pp. 40-45
4. R. P. Wei, "Fracture Mechanics Approach to Fatigue Analysis in Design," *Transactions of the ASME, Journal of Engineering Materials and Technology*, Vol. 100, No. 2, April 1978, pp. 113-120
5. D. V. Nelson, "Review of Fatigue-Crack-Growth Prediction Methods," *Experimental Mechanics*, Vol. 17, No. 2, February 1977, pp. 41-49
6. H. A. Wood, J. P. Gallagher, R. M. Engle and J. M. Potter, "Current Practice on Estimating Crack Growth Damage Accumulation with Specific Application to Structural Safety, Durability and Reliability," Air Force Flight Dynamics Laboratory Technical Report AFFDL-TR-75-32, January 1976
7. E647-78T, "Tentative Test Method for Constant-Load-Amplitude Fatigue Crack Growth Rates Above 10^{-8} m/Cycle," in 1979 Annual Book of ASTM Standards, American Society for Testing and Materials, Philadelphia, 1979, Part 10, pp. 703-721
8. T. W. Crooker, "The Need for Standards Development in Corrosion-Fatigue Testing with Precracked Specimens," *Standardization News*, Vol. 3, No. 5, May 1975, pp. 17-19,43
9. P. M. Scott, "The use of corrosion fatigue data in the assessment of crack growth in large nuclear pressure vessels," United Kingdom Atomic Energy Authority Report AERE-R8642, February 1977
10. W. H. Bamford, "Application of Corrosion Fatigue Crack Growth Rate Data to Integrity Analyses of Nuclear Reactor Vessels," *Transactions of the ASME, Journal of Engineering Materials and Technology*, Vol. 101, No. 3, July 1979, pp. 182-190
11. R. Johnson, A. McMinn and B. Tomkins, "Towards the Development of Mechanistically-Based Design Rules for Corrosion Fatigue in Ductile Steels" in PROCEEDINGS OF THE THIRD INTERNATIONAL CONFERENCE ON MECHANICAL BEHAVIOUR OF MATERIALS, Cambridge, England, 20-24 August 1979, Vol. 2, Edited by K. J. Miller and R. F. Smith, Pergamon Press, New York, 1979, pp. 371-379
12. G. A. Miller, S. J. Hudak, and R. P. Wei, "The Influence of Loading Variables on Environment-Enhanced Fatigue Crack Growth in High Strength Steels," *Journal of Testing and Evaluation*, Vol. 1, No. 7, Nov. 1973, pp. 524-531

13. P. S. Pao, W. Wei, and R. P. Wei, "Effect of Frequency on Fatigue Crack Growth Response of AISI 4340 Steel in Water Vapor," PROCEEDINGS OF THE CONFERENCE ON ENVIRONMENT-SENSITIVE FRACTURE OF ENGINEERING MATERIALS, Edited by Z. A. Foroulis, TMS-AIME, 1979, pp. 565-580
14. S. J. Hudak, Jr. and R. P. Wei, "Consideration of Nonsteady State Crack Growth in Material Evaluation and Design," Nuclear Technology (in press)
15. J. M. Barsom, "Effect of Cyclic Stress Form on Corrosion Fatigue Crack Propagation Below K_{Isc} in a High Yield Strength Steel" in CORROSION FATIGUE: CHEMISTRY, MECHANICS AND MICROSTRUCTURE, NACE-2, Edited by O. Devereux, A. J. McEvily, and R. W. Staehle, National Association of Corrosion Engineers, Houston, 1972, pp. 424-433
16. O. Vosikovsky, "Effects of Mechanical and Environmental Variables on Fatigue Crack Growth Rates in Steel", Canadian Metallurgical Quarterly, Vol. 19, 1980, pp. 87-97
17. R. J. Selines and R. M. Pelloux, "Effect of Cyclic Stress Wave Form on Corrosion Fatigue Crack Propagation in Al-Zn-Mg Alloys," Metallurgical Transactions, Vol. 3, September 1972, pp. 2525-2531
18. D. B. Dawson and R. M. Pelloux, "Corrosion Fatigue Crack Growth of Titanium Alloys in Aqueous Environments", Metallurgical Transactions, Vol. 5, 1974, pp. 723-731
19. B. F. Brown, "A New Stress-Corrosion Cracking Test for High-Strength Alloys," Materials Research & Standards, Vol. 6, No. 3, March 1966, pp. 129-133
20. R. P. Wei and R. L. Brazill, "An Assessment of AC and DC Potential Systems for Monitoring Fatigue Crack Growth", in FATIGUE CRACK GROWTH MEASUREMENT AND DATA ANALYSIS, ASTM STP 738, Edited by S. J. Hudak, Jr., and R. J. Bucci, American Society for Testing and Materials, 1981 (in press)
21. Ashok Saxena and S. J. Hudak, Jr., "Review and extension of compliance information for common crack growth specimens," International Journal of Fracture, Vol. 14, No. 5, October 1978, pp. 453-468
22. F. D. Bogar and T. W. Crooker, "The Influence of Bulk-Solution-Chemistry Conditions on Marine Corrosion Fatigue Crack Growth Rate," Journal of Testing and Evaluation, Vol. 7, No. 3, May 1979, pp. 155-159
23. J. E. Srawley, "Wide Range Stress Intensity Factor Expressions for ASTM Method E399 Standard Fracture Toughness Specimens," International Journal of Fracture, Vol. 12, No. 3, June 1976, pp. 475-476

APPENDICES

A.1. COD GAGE AND METHOD OF MOUNTING

A1.1 The recommended COD gage shall be in accordance with the double cantilever clip-in displacement gage specified in Reference A1. Such gages can either be procured from a commercial manufacturer or constructed in accordance with the detailed drawings and specifications provided in Reference A1.

A1.2 The COD gage shall be mounted on knife edges located above and below the notch on the edge of the CT or WOL specimens, as specified in Reference A1. The knife edges may either be integral or attached. An example of a commercial COD gage mounted on a WOL specimen using attached knife edges is shown in Fig. A1.

A2. ENVIRONMENTAL CHAMBER AND CIRCULATION SYSTEM

A2.1 The general features and layout of the recommended environmental chamber and circulation system are shown in Fig. A2 for a CT or WOL specimen mounted in a loading frame with a horizontal load actuator. The environmental chamber provides for full immersion of the specimen below the level of the notch tip, while preventing the grips and loading pins from coming in direct contact with the environment solution. Circulation through the test chamber is controlled by gravity feed from the reservoir. Solution is returned to the reservoir from the test chamber by means of a pump. Solution inlet to the test chamber is located at the minimum level and the outlet is near the maximum level to assure a flow of fresh solution around the test specimen. Aeration of the solution is achieved in the reservoir and a filter is placed in the circulation loop.

A3. MEASUREMENT OF ELECTROCHEMICAL POTENTIAL

A3.1 Scope — This method provides conventions for reporting electrochemical potential measurements and describes an experimental procedure for measurement of potential during fatigue testing. This method is limited to aqueous solutions and temperatures ranging from 10⁰ to 60⁰C at normal atmospheric pressure.

A3.2 Sign Convention for Electrode Potential — The Stockholm sign invariant convention is recommended for use in reporting specimen potential measurements in accordance with ASTM [A2] and IUPAC [A3] recommendations. The SI unit of electric potential is the volt [A4]. The positive direction of electrode potential, the so-called "noble" direction, indicates an increasing oxidizing condition of the corroding specimen.



Reaction 1 is enhanced in the direction from left to right by an increase in potential. The negative direction signifies reduction in this convention. Electrochemical processes which result in the reduction of electrochemically active species are favored as the negative or active direction is increased. Thus, the evolution of molecular hydrogen gas is increased as in reaction 2 by a decrease in potential on the metal surface.



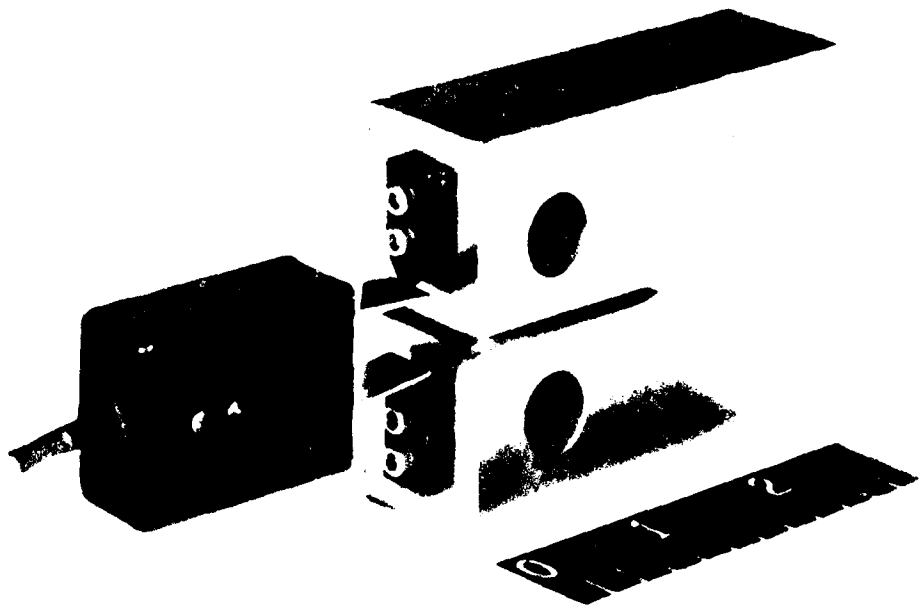

Fig. A1 — WOL specimen with clip-in COD gage using attached knife edges

R-0122

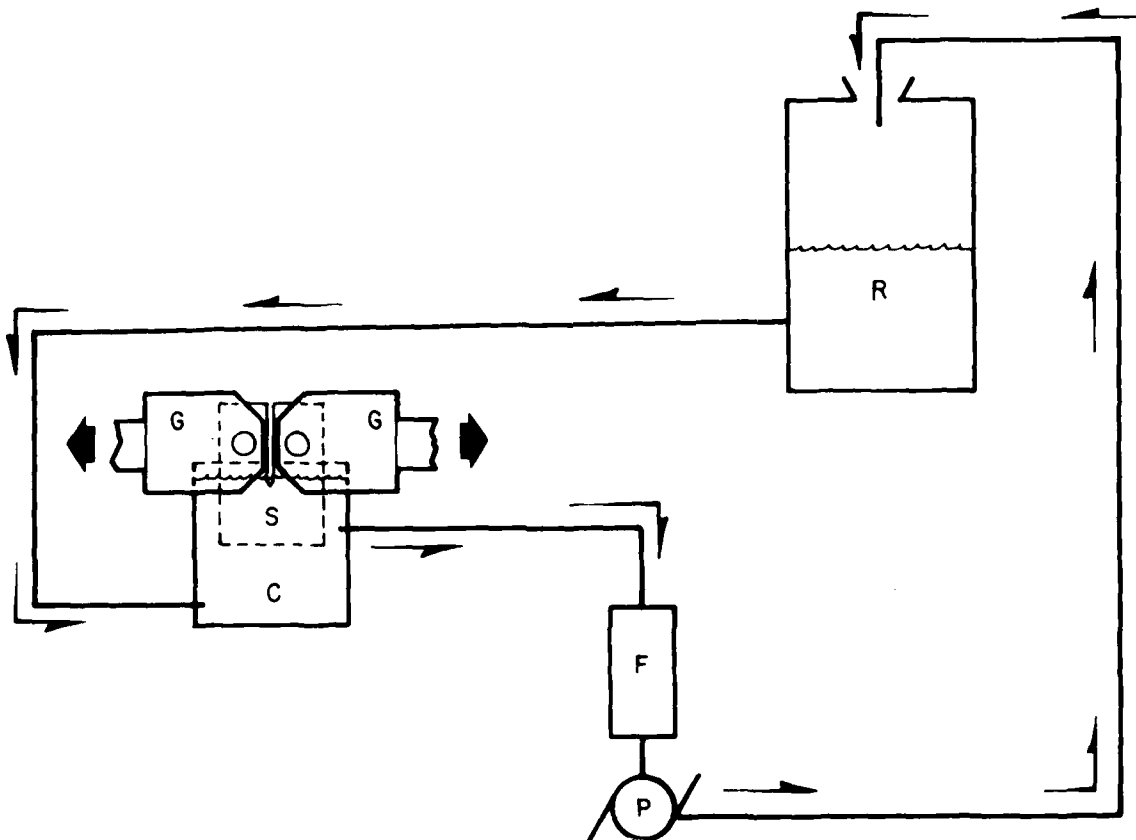

Fig. A2 — Recommended environmental circulation system showing the WOL or CT test specimen (S), grips (G), environmental chamber (C), reservoir (R), pump (P), and filter (F).

Using this convention, the noble metals such as platinum, gold, titanium and silver all have positive standard free energy of corrosion potentials in aqueous solutions. On the other hand, the others having a convention includes that active metals such as lithium, sodium, beryllium, calcium, magnesium, and zinc all have negative potentials.

A3.3.1 Apparatus - Electrode potential measurements require the use of a reference electrode and instrumentation for measuring the electrode potential.

A3.3.1.1 The saturated calomel electrode (SCE) is recommended because it is readily available and inexpensive. However, other electrodes have many advantages and should be used where applicable. The silver-silver chloride electrode is particularly advantageous in studies in natural seawater (A3.1) where even traces of chloride ion can be detrimental. The mercury-mercurous sulfate electrode can be substituted. A detailed list of various electrode potentials of the various electrodes can be found in reference A6.

Since the filling solution of the reference electrode will most often not be the same as the environment used in the corrosion fatigue test and since the potential of the reference electrode is dependent upon the known constant concentration of ingredients in the filling solution, some care must be provided to prevent the mixing of the two solutions. A capillary device can be used for this purpose. Several capillary devices are described in reference A6. A convenient arrangement for use with silver-silver chloride electrode is shown in figure A3.

A3.3.1.2 Generally, any instrument with an input impedance of 10^{11} to 10^{14} ohms and a sensitivity and accuracy of better than 0.1 mV over the potential range from -1.0 to +1.0 V will be suitable for the purpose of this procedure. Simple digital voltmeters can be used, however, for exacting analysis only due to the ability to detect changes during the corrosion process. The high impedance is used to minimize current used by the instrument which for highly conductive solutions such as seawater, the requirement for high input impedance is greatly lessened.

A3.3.1.3 Connect the voltmeter or potentiometer to the reference electrode and the specimen under test. If electrical contact from the fatigue specimen through the grips can be insured, the point of contact may be any convenient spot on the fixture. However, the necessity of avoiding contact between the grips and the test environment cannot be overemphasized. It is good practice to coat the grips and fixtures with an inert grease such as Teflon high vacuum grease to prevent creeping of the environment. As these greases may contain inhibitors, care must be taken to keep them from the environment where possible. The point of electrical contact with the fatigue specimen should be on the specimen itself where possible. Non-conducting films, layers of rust, and corrosion products all lead to errors in potential measurements.

Generally, a metal when placed in an electrolyte solution will not achieve a fixed potential under most conditions, for days or even months. Therefore, a fixed time interval is usually stressed when potential measurements are reported "The potential of pure copper in deaerated seawater at 30°C after one hour was -0.340 volts vs. SCE". As in the above example, a meaningful measurement of potential must be reported with a detailed description of the environment.

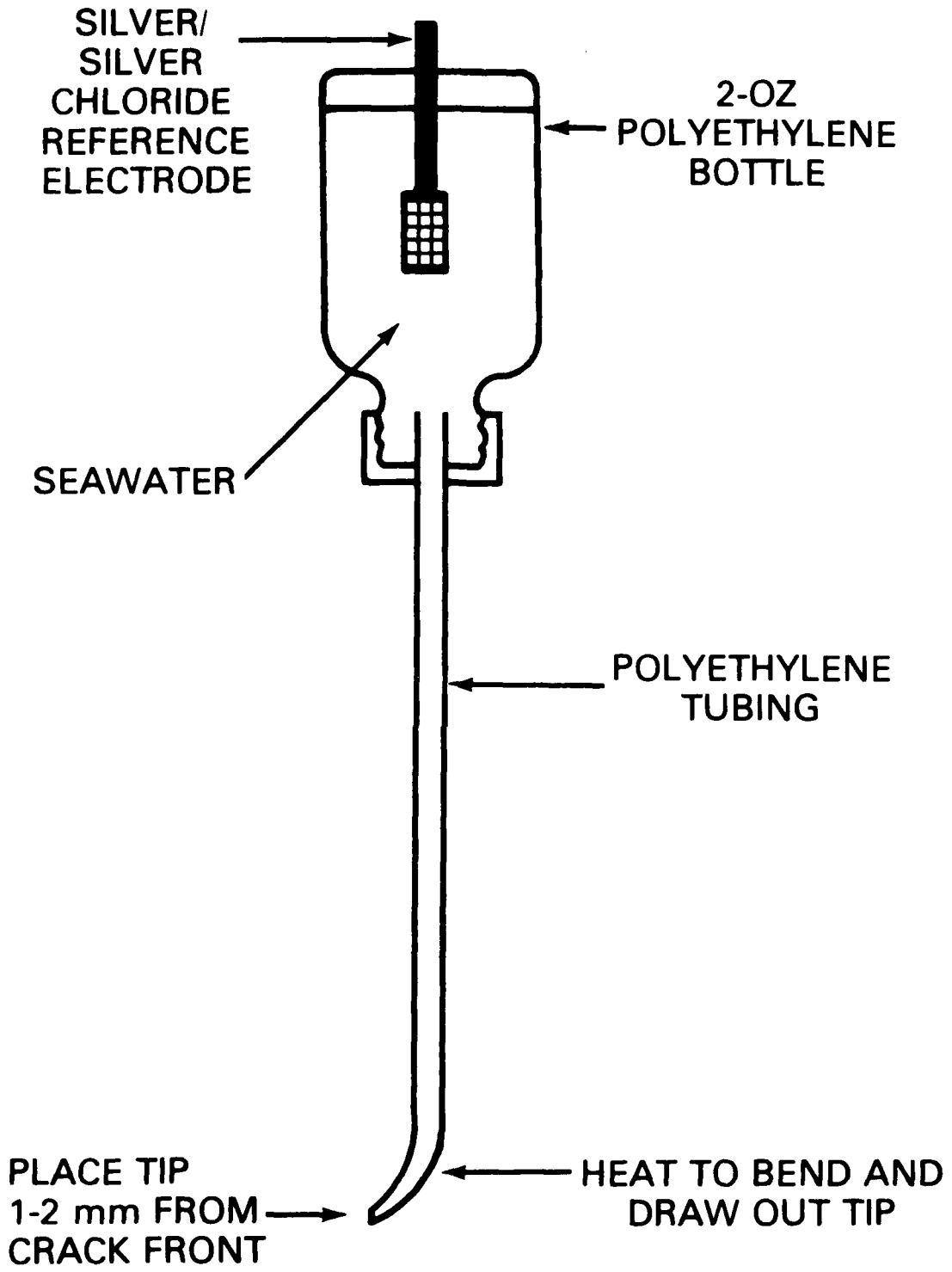

Fig. A3 — A convenient capillary device which incorporates the silver-silver chloride reference electrode for use in natural seawater and similar electrolytes.

REFERENCES

- A1. E399-78a, "Standard Test Method for Plane-Strain Fracture Toughness of Metallic Materials", in 1980 Annual Book of ASTM Standards, American Society for Testing and Materials, Philadelphia, 1980, Part 10, pp. 580-601
- A2. G3-74, "Standard Recommended Practice for Conventions Applicable to Electrochemical Measurements in Corrosion Testing," in 1980 Annual Book of ASTM Standards, American Society for Testing and Materials, Philadelphia, 1980, Part 10, pp. 794-802
- A3. ELECTROCHEMICAL DEFINITIONS AND SYMBOLS, International Union of Pure and Applied Chemistry, Oxford, 1972
- A4. E380, "Standard for Metric Practice", in 1980 Annual Book of ASTM Standards, American Society for Testing and Materials, Philadelphia, 1980, Part 10, pp. 1065-1084
- A5. M. H. Peterson and R. E. Groover, "Tests Indicate the Ag/AgCl Electrode Is Ideal Reference Cell In Sea Water", Materials Protection and Performance, Vol. 11, 1972, pp. 19-22
- A6. D. J. G. Ives and G. J. Jane, REFERENCE ELECTRODES THEORY AND PRACTICE, Academic Press, New York, 1961

DATE
FILMED
— 8