

LEVEL III

EVALUATION

OF

**COAL GASIFICATION/COMBINED CYCLE
POWER PLANT FEASIBILITY**

①

AD A103675

DTIC
ELECTE
SEP 2 1981
D
H

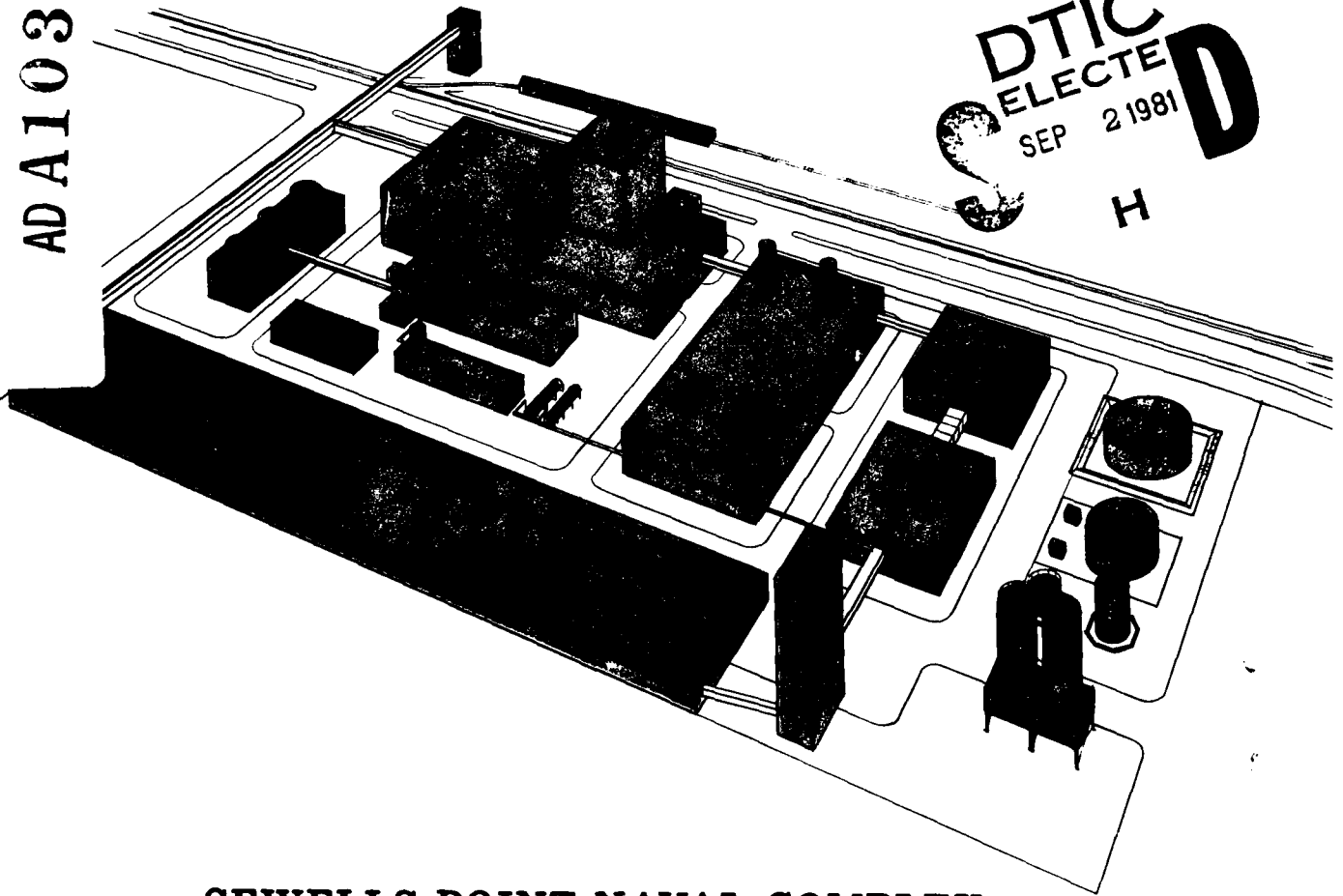

**SEWELLS POINT NAVAL COMPLEX
NORFOLK, VIRGINIA**

SUMMARY

JULY 1981

DISTRIBUTION STATEMENT A
Approved for public release;
Distribution Unlimited



**POPE, EVANS AND ROBBINS INCORPORATED
CONSULTING ENGINEERS**

DTIC FILE COPY

80 8 28 133

REPORT DOCUMENTATION PAGE		READ INSTRUCTIONS BEFORE COMPLETING FORM
1. REPORT NUMBER	2. GOVT ACCESSION NO. AD-A103 675	3. RECIPIENT'S CATALOG NUMBER
4. TITLE (and Subtitle) Evaluation of Coal Gasification/Combined Cycle Power Plant Feasibility at the Sewells Point Naval Complex, Norfolk, VA		5. TYPE OF REPORT & PERIOD COVERED Final Report
		6. PERFORMING ORG. REPORT NUMBER
7. AUTHOR(s)		8. CONTRACT OR GRANT NUMBER(s) N62470-80-C-3736
9. PERFORMING ORGANIZATION NAME AND ADDRESS Pope, Evans and Robbins 26 Broadway New York, NY 1004		10. PROGRAM ELEMENT, PROJECT, TASK AREA & WORK UNIT NUMBERS
11. CONTROLLING OFFICE NAME AND ADDRESS Naval Facilities Engineering Command, Code 111 200 Stovall Street Alexandria, VA 22332		12. REPORT DATE July 1981
		13. NUMBER OF PAGES 265
14. MONITORING AGENCY NAME & ADDRESS (if different from Controlling Office)		15. SECURITY CLASS. (of this report) Unclassified
		15a. DECLASSIFICATION/DOWNGRADING SCHEDULE
16. DISTRIBUTION STATEMENT (of this Report) Unlimited		
17. DISTRIBUTION STATEMENT (of the abstract entered in Block 20, if different from Report)		
18. SUPPLEMENTARY NOTES This study is in two volumes Summary - 30 pages ✓ Final Report - 235 pages		
19. KEY WORDS (Continue on reverse side if necessary and identify by block number) Coal, coal gasification, cogeneration, combined cycle, generation, power plant, central steam plant.		
20. ABSTRACT (Continue on reverse side if necessary and identify by block number) This study evaluates the feasibility of installing a coal gasification/combined cycle cogeneration plant at Sewells Point Naval Complex, Norfolk, Virginia. The study addresses current gasification technology, combined cycle thermodynamics, environmental control requirements, and conventional coal fired cogeneration cycles. The utility interface, site considerations and economic analyses are also presented. The study concludes that a coal gasification/combined cycle cogeneration plant supplying 50 MW of electric power and 290,000 lb/hr of steam is technically feasible.		

**DTIC
SELECTED
SEP 2 1981
S H D**

①

EVALUATION OF COAL GASIFICATION/COMBINED CYCLE
POWER PLANT FEASIBILITY

AT THE

SEWELLS POINT NAVAL COMPLEX,
NORFOLK, VIRGINIA.

Summary
Final Rept.

SUMMARY

⑪

JUL 1981

⑫
130

15) N62470-80-C-37361

DISTRIBUTION STATEMENT A
Approved for public release;
Distribution Unlimited

POPE, EVANS AND ROBBINS
286354

TABLE OF CONTENTS

		<u>PAGE</u>
1.0	EXECUTIVE SUMMARY	1
	Purpose of Study	1
	Conclusions	1
	Recommendations	3
	Acknowledgements	3
2.0	TECHNICAL REPORT SUMMARY	7
	Characteristics of Sewells Point Naval Complex	7
	Summary of Coal Gasification/Combined Cycle Analyses	7
	Summary of Conventional Technology Analyses	18
	Economic Results	18
	National Applicability	26

Accession For	
NTIS GRA&I	<input checked="" type="checkbox"/>
DTIC TAB	<input type="checkbox"/>
Unannounced	<input type="checkbox"/>
Justification	
By _____	
Distribution/Availability Codes	
Dist	Spec 1
A	

LIST OF EXHIBITS

		<u>PAGE</u>
Exhibit 1	Coal Gasification/Combined Cycle Cogeneration Plant	2
Exhibit 2	SPNC Summary of Annual Energy Use Summary of First Year Operating Costs (\$1981)	4
Exhibit 3	Integrated Coal Gasification/Combined Cycle Third Party Financing	5
Exhibit 4	Potential Energy Savings for Coal Gasification/ Combined Cycle Cogeneration Cycles at Selected Candidate Industries	6
Exhibit 5	Load Projections for SPNC	8
Exhibit 6	Generic Combined Cycle/Gasification Plant Flow Diagram	9
Exhibit 7	Gasifier Performance Summary	12
Exhibit 8	Comparison of Commercially Available Gasifiers	13
Exhibit 9	Summary of Commercially Available Environmental Control Processes	15
Exhibit 10	Integrated Combined Cycle Performance Summary	16
Exhibit 11	Integrated Coal Gasification/Combined Cycle Plant Thermal-to-Electric Load Ratio	17
Exhibit 12	Summary of Results for Back Pressure Turbine Operation	19
Exhibit 13	Comparison of VEPCO Rate Schedules	20
Exhibit 14	Comparison of Escalation Rates	21
Exhibit 15	Life Cycle Cost Analysis Integrated Combined Cycle/Gasification vs. Continued Operation of Oil Plant (NAVFAC Escalation)	23
Exhibit 16	Life Cycle Cost Analysis Integrated Combined Cycle/Gasification Escalation Rate Comparison (100% Equity)	24
Exhibit 17	Effect of Coal Gasification Costs 25 Year Life Cycle Evaluation	25

1.0 EXECUTIVE SUMMARY

PURPOSE OF STUDY

The Sewells Point Naval Complex (SPNC), Norfolk, Virginia, is the largest single energy consumer in the U.S. Naval shore establishment. The SPNC steam and electric requirements are developed traditionally: boilers for the thermal load and public utility purchase for the electric load. The dramatic rise in energy cost and the need to reduce dependency on foreign oil makes it natural to ask if such loads can be developed more economically.

This study is jointly funded by the U.S. Navy Naval Facilities Engineering Command (NAVFAC) and U.S. Department of Energy (DOE) as an Energy Showcase Project. The purpose of the study is to determine a most suitable cogeneration scheme for installation at SPNC that is consistent with the Energy Showcase program goals. A coal gasification/combined cycle (cg/cc) power plant employing currently available equipment and process technology serves as the basic scheme assessed.

CONCLUSIONS

This Summary presents the elements of the study leading to the following conclusions:

- I. A Navy-owned coal gasification/combined cycle cogeneration plant for SPNC sized to provide approximately 50 MW of power and 290,000 lb/hr of steam:
 - is technically feasible;
 - has components which are competitively available from several manufacturers offering commercial warranties;
 - has a construction cost in 1981 dollars estimated at \$154 million;
 - yields annual operating savings, in 1981 dollars, of \$21 million;
 - provides annual savings of approximately 320,000 barrels of oil equivalent.

On the basis of life cycle costs, using NAVFAC escalation rates, the discounted payback period is 4.1 years and using DOE rates, the discounted payback period is 7.2 years. Under either escalation scenario, this project is economically attractive. A typical plant layout of the cg/cc at SPNC is shown in Exhibit 1. Fuel and energy use and costs compared to current operations on oil are presented in Exhibit 2.

COAL GASIFICATION/COMBINED CYCLE COGENERATION PLANT
FOR
SEWELLS POINT NAVAL COMPLEX
NORFOLK, VIRGINIA

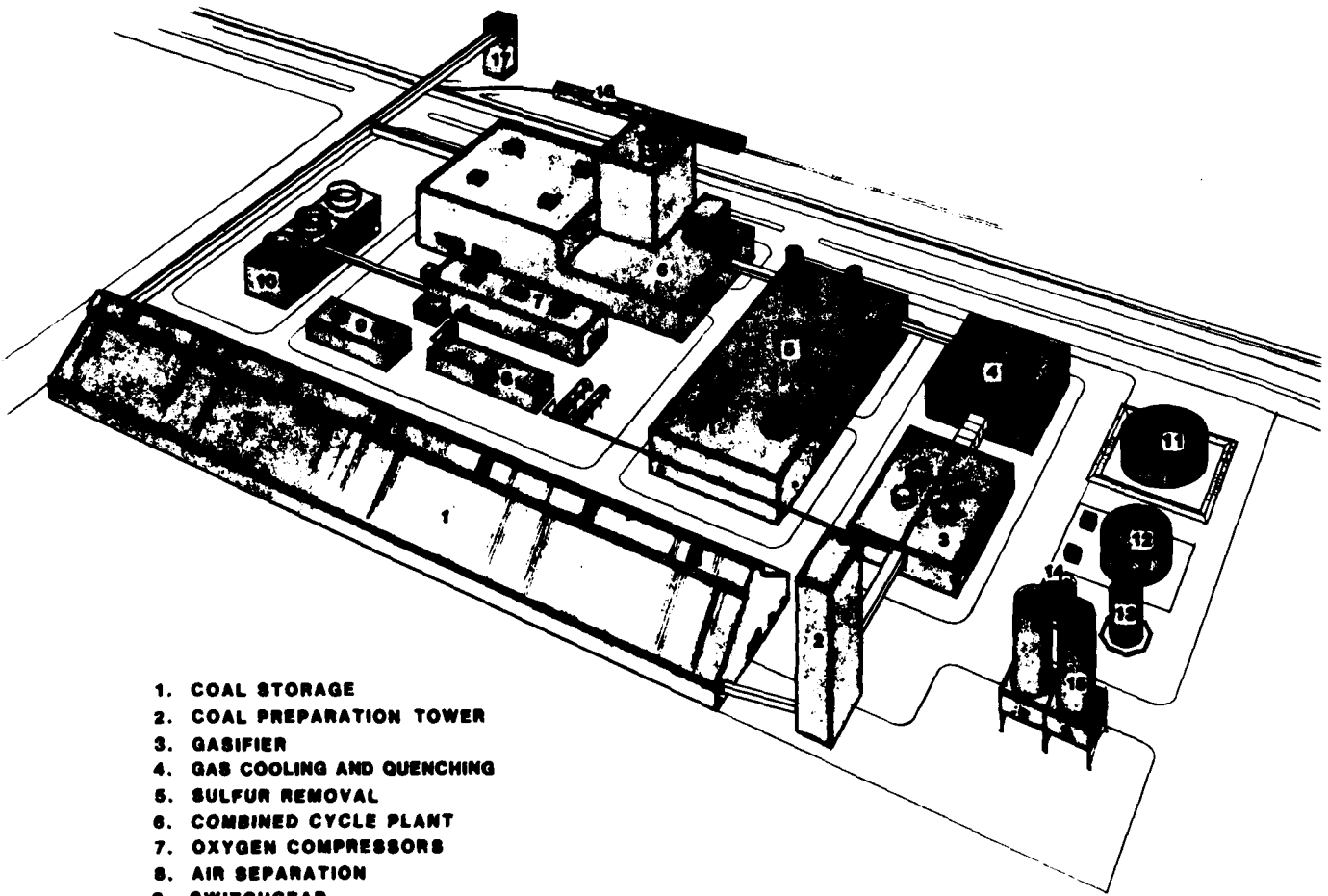

1. COAL STORAGE
2. COAL PREPARATION TOWER
3. GASIFIER
4. GAS COOLING AND QUENCHING
5. SULFUR REMOVAL
6. COMBINED CYCLE PLANT
7. OXYGEN COMPRESSORS
8. AIR SEPARATION
9. SWITCHGEAR
10. OXYGEN PLANT COOLING TOWER
11. TAR STORAGE (IF REQUIRED)
12. WASTE WATER TREATMENT
13. FIRE RESERVE
14. RECYCLE WATER
15. ASH SILOS
16. COAL TRAIN UNLOADING
17. COAL CONVEYOR TOWER

II. Currently available investment and energy tax credits and accelerated depreciation allowances make this project a prime candidate for leverage lease financing under third-party private sector ownership. Under such a scheme the U.S. Navy would realize the very substantial savings in cost and energy without the need to appropriate funds for the coal gasification/combined cycle plant. Using current investor goals of a return on equity of 20% after taxes, the involvement of the private sector at SPNC can save the U.S. Navy \$780 million over the life of a 15 year lease. The results of a typical third-party financing scheme are displayed in Exhibit 3. There the annual operating costs for an investor-owned cg/cc plant are compared to continuation of current SPNC oil firing/purchased power. A significant opportunity for both NAVFAC and the private sector is evident.

III. There are major energy intensive industries that are candidates for a cg/cc plant. Energy consumption and potential savings for selected industries are shown in Exhibit 4; annual savings of 260 million barrels of oil can accrue. The cg/cc at Sewells Point can, therefore, well serve as a model for demonstrating economic and technical feasibility prior to its widespread industrial use.

Thus implementation of a cg/cc plant at SPNC satisfies all the major goals of Energy Showcase projects.

RECOMMENDATIONS

Based on these results, the recommendations of this study are that:

- cogeneration at SPNC be pursued as quickly as possible,
- coal gasification/combined cycle be the technology employed at SPNC,
- the private sector be actively solicited for third-party ownership financing.

ACKNOWLEDGEMENTS

Pope, Evans and Robbins is pleased to acknowledge the considerable assistance provided by the U.S. Naval Facilities Engineering Command project manager, Mr. James Torma. We are also pleased to thank Mr. Heinz Gorges, NAVFAC Consultant, for the many helpful discussions, criteria and calculations he so generously provided.

SEWELLS POINT NAVAL COMPLEX
SUMMARY OF ANNUAL ENERGY USE

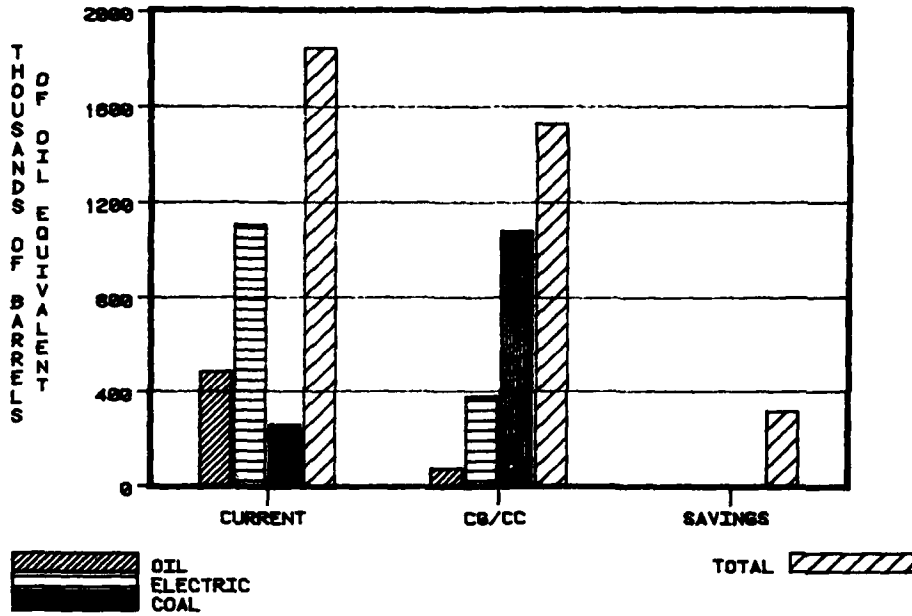

SEWELLS POINT NAVAL COMPLEX
SUMMARY OF FIRST YEAR OPERATING COSTS (\$1981)

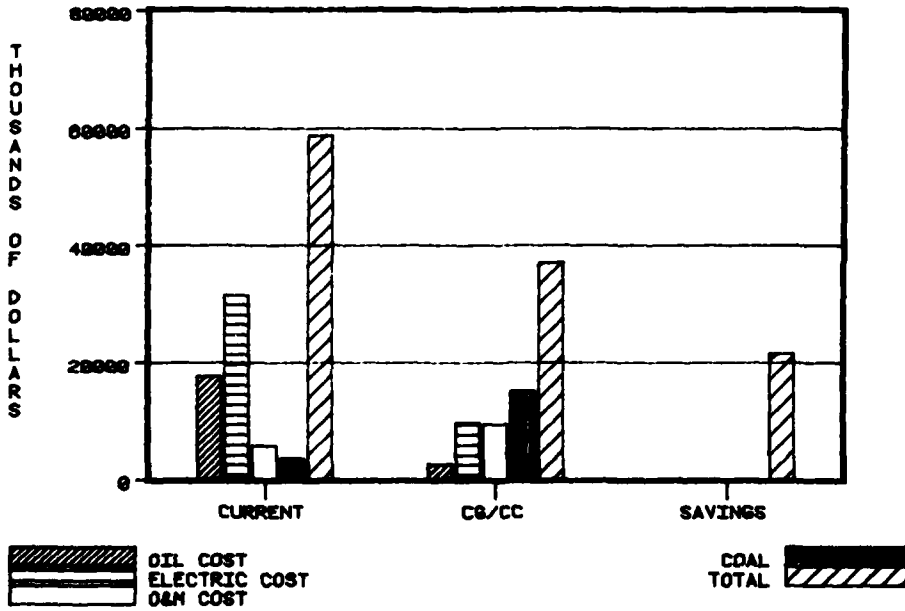

INTEGRATED COAL GASIFICATION/COMBINED CYCLE THIRD PARTY FINANCING

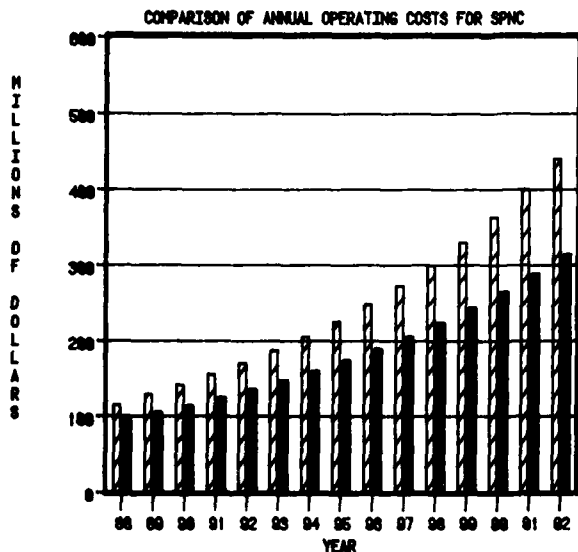

CURRENT OIL FIRING/PURCHASED POWER
 THIRD PARTY FINANCED CG/CC

BASIS OF ANALYSIS (1981 DOLLARS)

TOTAL CONSTRUCTION COST	\$164,000,000
CONSTRUCTION INTEREST	\$16,400,000
INVESTMENT & ENERGY TAX CREDIT	\$23,000,000
DEBT	\$110,000,000
EQUITY	\$50,000,000
DEBT LIFE (YEARS)	15
INTEREST ON DEBT (%)	17.0
TAX RATE (%)	40.0
RETURN ON EQUITY (%)	20.0

NAVFAC CASH FLOW ANALYSIS
SEMELLS POINT THIRD PARTY FINANCING

YEAR	LEASE COST	COAL COST	OSH COST	ELECTRIC SAVINGS	OIL SAVINGS	NAVFAC SAVINGS
1	-37,690	-29,360	-6,720	38,740	34,470	1,440
2	-37,690	-32,038	-7,298	41,644	40,949	5,609
3	-37,690	-34,959	-7,838	44,749	45,977	10,258
4	-37,690	-38,148	-8,465	48,127	51,623	15,447
5	-37,690	-41,627	-9,142	51,736	57,962	21,239
6	-37,690	-45,423	-9,874	55,616	65,080	27,709
7	-37,690	-49,566	-10,664	59,788	73,072	34,940
8	-37,690	-54,086	-11,517	64,272	82,045	43,024
9	-37,690	-59,019	-12,438	69,092	92,120	52,045
10	-37,690	-64,401	-13,433	74,274	103,433	62,182
11	-37,690	-70,275	-14,508	79,844	116,134	73,506
12	-37,690	-76,684	-15,669	85,833	130,395	86,186
13	-37,690	-83,677	-16,922	92,270	146,408	100,389
14	-37,690	-91,309	-18,276	99,190	164,387	116,303
15	-37,690	-99,636	-19,738	106,630	184,574	134,139
TOTAL	-545,350	-870,208	-182,462	1,011,825	1,390,620	784,433

INFLATION RATE	0.08
DIFFERENTIAL ESCALATION RATES:	
COAL	0.0112
ELECTRIC	-0.005
OSH	0
OIL	0.0428

EXHIBIT 3

POTENTIAL ENERGY SAVINGS
FOR
COAL GASIFICATION/COMBINED CYCLE COGENERATION CYCLES
AT
SELECTED CANDIDATE INDUSTRIES

<u>Industry</u>	<u>Process Energy Requirements (10⁶ BOE/yr)</u>	<u>Average Electric Demand (kW) Per 10⁶ Units</u>	<u>Units (10⁶)</u>	<u>Potential Oil Savings (10⁶ BOE/yr)</u>	<u>Potential Net Energy Savings (10⁶ BOE/yr)</u>
Newsprint	21.1	137	4.1 tons	15.8	3.8
Writing Paper	31.4	101	3.6 tons	10.3	2.5
Corrugated Paper	154.7	68	18.5 tons	35.5	8.5
Boxboard	47.1	89	4.9 tons	12.3	2.9
Petroleum	195.1	0.3	6143 runs	59.4	14.3
Steel Mill	789.0	26	155 tons	113.2	27.2
Gray Iron Foundry	<u>29.9</u>	58	9.8 tons	<u>15.8</u>	<u>3.8</u>
TOTAL	1268.3			262.3	63.0

-
1. Electric requirements derived from source energy at 11,600 Btu/kWh.
 2. Derived from coal gasification/combined cycle performance: energy saved from utility = 11,600 Btu/kWh, energy saved from thermal recovery = 8600 Btu/kWh.
 3. Coal requirements for system = 15,400 Btu/kWh.

Note that BOE = barrels of oil equivalent.

2.0 TECHNICAL REPORT SUMMARY

Details of the analyses carried out during this effort are provided in the companion Technical Report and related Appendices which include all data bases, computations and supporting information. A summary of the Technical Report follows.

CHARACTERISTICS OF SEWELLS POINT NAVAL COMPLEX

At the central power plant for SPNC steam is generated by seven oil fired boilers and is used primarily to provide steam services for pier cold iron, base industrial processes and building heating. An eighth boiler, capable of firing pulverized coal and No. 6 oil, has been installed but not commissioned as of this date. Aside from this new boiler the facility is old by industrial standards.

Another boiler plant is located near the waterfront. It consumes the waste products of the activity and produces steam from the heat generated by incineration. Two other existing plants are used as peaking units during winter. While these plants are not directly involved in the potential new facility their capacities totalling 410,000 lb/hr are important for a total perspective of the SPNC facilities.

To effectively establish SPNC requirements for any new cogeneration scheme, loads were projected to the 1988 time period. This is the assumed date for the coal gasification/combined cycle to go on line. Elements of the projection and loads are displayed in Exhibit 5. We have identified a steam export load of approximately 290,000 lb/hr (at 340 psig, sat.) occurring for the full year and a base electric requirement of 50-60 MW for the full year.

SUMMARY OF COAL GASIFICATION/COMBINED CYCLE ANALYSES

The basic coal gasification/combined cycle flow diagram is shown in Exhibit 6. The major process steps are:

- Oxygen Plant - Required for medium-Btu gas, the major components of an oxygen plant are an air compressor, an air separation unit including heat exchangers, cold box components and expansion turbines, nitrogen compressors for purging requirements and an oxygen compressor.
- Gasification Plant - The gasifier may be either oxygen or air blown and of the fixed, fluidized or entrained bed type.

LOAD PROJECTIONS FOR SPNC¹

	<u>1979</u>	<u>1988</u>
I. STEAM		
Annual Steam Generation (10^9 lb/yr)	3.6	4.6
Annual Steam Export (10^9 lb/yr)	2.9	3.8
Base Load Steam Demand (lb/hr)	250,000	290,000
II. ELECTRIC		
Annual Electric Consumption (10^6 kWh/yr)	500	600
Peak Electric Demand (MW)	100	130
Baseload Electric Demand (MW)	50-60	50-60

1. Predicted annual growth rate of 2% accounting for conservation.

GENERIC COMBINED CYCLE/GASIFICATION PLANT FLOW DIAGRAM

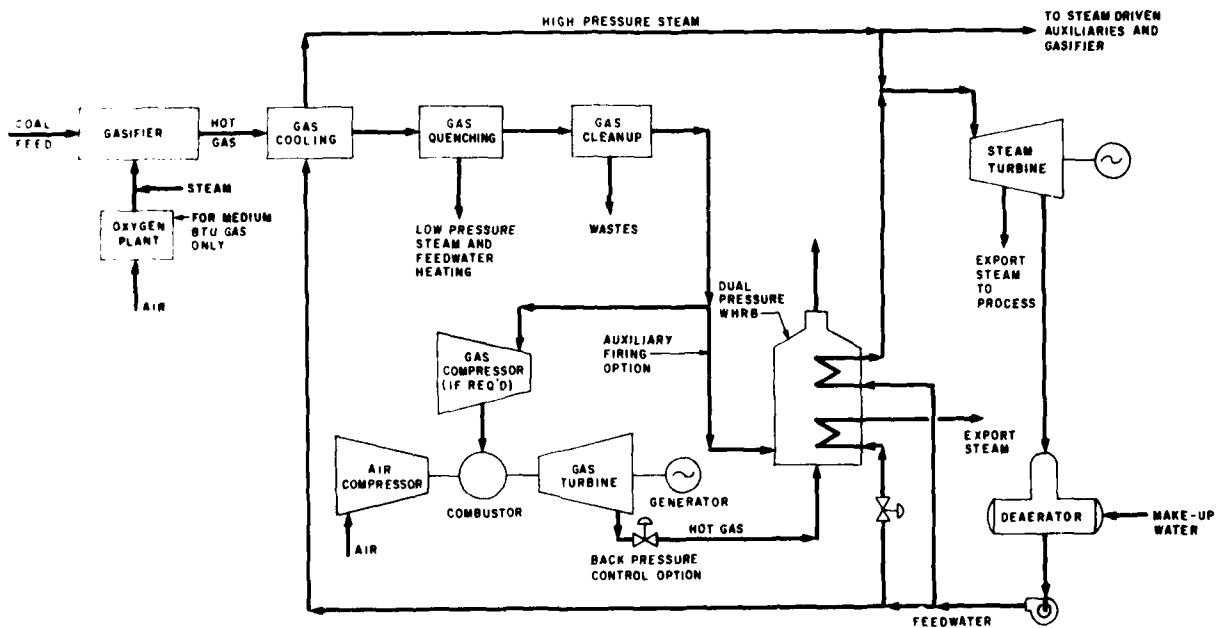

- Gas Cooling and Quenching - This process is dependent on gasifier type and the method of gas cleanup.
- Gas Cleanup - There are several processes that must take place here; these include particulate control for the hot gas, organic separation of tars and oils as appropriate to the various gasifiers and acid gas removal with potential sulfur recovery.
- Gas Compression - This step is necessary for all atmospheric gasifiers. For the pressurized-type, oxygen compression is required prior to the gasifier and to a higher pressure level than that of the gas turbine combustor.
- Gas Turbine Generator - Except for the combustor, the gas turbine generator component is the same as any used in conventional fossil fuel fired combined cycle plants. Manufacturer data indicates that with combustor modifications medium Btu coal derived gas can be fired in existing gas turbine units. The firing of low Btu gas in combustion turbines is not now available.
- Waste Heat Recovery Boiler (WHRB) - The sensible heat in the turbine exhaust gas is recovered and converted to steam in this step.
- Steam Turbine - The steam from both the WHRB and the gas cooling process, if any, is expanded in a conventional back pressure steam turbine.

The scheme shown in Exhibit 6 presents the combined cycle integrated with the gasification plant, i.e., there is an interchange of electrical power, feedwater and steam between systems. Previous studies have shown this scheme to be the most economical and one which results in the highest overall thermal efficiency. This is especially the case in a cogeneration plant where all steam driven auxiliaries including those in the oxygen plant can operate in a back-pressure mode, thereby leading to a more favorable steam-to-power ratio.

Basically these various components are well understood and most have been in service for many years. The only exceptions to this are the gasification process itself and the gas cleanup technologies.

Coal gasification processes are categorized according to the techniques in which the various reactants -- coal, steam, oxidant (air or oxygen) -- contact each other and according to the movement of the coal itself. In general, we address three types: fixed bed, fluidized bed and entrained bed.

Various gasifiers falling into the three generic categories were screened according to several factors so that a small representative set might be

established for detailed performance analysis and economic evaluation. The major elements for screening are:

Status - This factor pertains to the degree of development or commercialization. Those processes that were commercial or were thought to become commercially available by the time of facility design were favored.

Technology Factors - These included complexity, feed coal types, operating experience and conditions and conversion efficiency; we sought to include representative processes from the three generic classes.

Capacity - The number of gasifiers needed to handle selected amounts of coal was evaluated. Since this is not a utility-type operation but rather an industrial gasification application, low to moderate capacity was favored.

Data Availability - Notwithstanding any of the above factors, data availability in the open literature was considered of prime importance. If the system under evaluation did not have a base sufficient for cycle assessment, it was deemed unsuitable for this feasibility study.

On these bases the following were selected as representative of the commercially available systems:

<u>Fixed Bed</u>	Lurgi, dry ash Wellman-Galusha Woodall-Duckham
<u>Fluidized Bed</u>	Winkler
<u>Entrained Bed</u>	Koppers-Totzek Texaco

These six may not be the only gasifiers which can fit current state-of-the-art criteria, but rather are representative of the variety of systems that are available.

For each of the six gasifiers Exhibit 7 provides typical performance parameters and Exhibit 8 compares advantages and disadvantages.

The sources of air, liquid and solid waste effluents for gasification/combined cycle systems arise from the several steps in the process:

- coal storage, treatment and processing
- gasification
- gas purification
- gas turbine combustor and exhaust stack

For environmental control we maintained the guideline of only selecting commercially available equipment; selection criteria therefor were the

GASIFIER PERFORMANCE SUMMARY

Parameter	FIXED BED			FLUIDIZED BED	ENTRAINED BED	
	<u>Lurgi</u>	<u>Woodall-Duckham</u>	<u>Wellman-Galuaha</u>	<u>Winkler</u>	<u>Koppers-Totzek</u>	<u>Texaco</u>
● OPERATING CONDITIONS						
Coal Feed Rate (tons/day/gasifier)	400-600	200	80-120	700-1000	400	150-300
Pressure (psig)	350-450	Atmospheric	Atmospheric	Atmospheric	Atmospheric	400-1200
Coal Size (inches)	1/8-1-1/2	1/4-1-1/2	1-2	0-3/8	Pulverized	Pulverized
● INPUT REQUIREMENTS						
Oxidant (lb/lb coal)						
Air (low Btu gas)	1.5-2.2	2.3	2.5-3.5	1.7-3.0	-	-
Oxygen (medium Btu gas)	0.4-0.6	0.5	1.5	0.4-0.7	0.6-0.9	0.6-0.9
Steam (lb/lb coal)	1.0-3.2	0.4-1.4	0.3-0.8	0.4-0.7	0.2-0.7	0.1-0.6
Water (gal/ton coal)	500-600	60	70	200-300	300-600	100-200
Electric (kWh/ton coal)	25	20-35	120	10-25	55	50
● COLD GAS EFFICIENCY						
Coal to Gas (%)	63-80	68-76	67-77	65-72	75	70-80

COMPARISON OF COMMERCIALY AVAILABLE GASIFIERS

<u>GASIFIERS</u>	<u>ADVANTAGES</u>	<u>DISADVANTAGES</u>
<u>Fixed Bed</u>		
Lurgi, Dry Ash	Pressurized; turndown; caking coals.	Tars and oils; solids handling against high pressure.
Wellman-Galusha	Turndown; good efficiency.	Tars and oils; close bed temperature control required; low pressure.
Woodall-Duckham	Turndown; two stages; no direct water quenching required.	Tars and oils; limited to non-caking coals; bed temperature control required; low pressure.
<u>Fluidized Bed</u>		
Winkler	Turndown; all coals; clean effluent; low steam use.	Ash and char carryover; unconverted coal trim limits efficiency; low pressure.
<u>Entrained Beds</u>		
Koppers-Totzek	All coals; clean effluent; low steam use.	Small turndown; high oxygen requirement; ash removal problem; low pressure.
Texaco	All coals; clean effluent; turndown; pressurized.	Slurry feed; no real demonstration yet; close control of oxygen required.

same used to screen the gasifiers. A summary of available processes for for each of the steps is provided in Exhibit 9. With the appropriate matching of gasification process to controls, all pertinent environmental regulations can be met.

Due to the complexity of the integrated combined cycle, a computer model was used to facilitate the numerous runs required in the cycle performance evaluation. The computer model used is an industry standard employs "building-blocks" or elementary components, to model the physical components of the power plant.

Base case comparisons for a 60 MW gas turbine are shown in Exhibit 10 for the several gasifiers. Significant differences are apparent:

- the fixed bed provides comparatively small steam flows for cogeneration.
- both the fixed and fluidized beds have low overall efficiency.
- the fluidized bed with its carbon carryover and char formation has a high coal use.

In addition to these base cases, a number of cycle modifications were assessed. These included:

- improvements to fixed bed gasifier performance by providing auxiliary coal gas firing; results indicate that the significant increase in coal consumption probably does not warrant such operation.
- effects of combustion inlet temperature for the gas turbines; the performance improvements at temperatures up to 2600°F are not significant for industrial-based cg/cc systems.
- variations in gas turbine back pressure, i.e., underexpanding to maintain high exhaust temperatures and thereby increasing steam output; such back pressure control can provide a significant means for varying system thermal-to-electric ratio.

For an overall perspective on gasifier performance and the actual load output at SPNC consider Exhibit 11. Here we show steam and electric load ratios in energy terms. Superimposed thereon are the results of the several cycle analyses. Clearly the Koppers-Totzek and Texaco gasifiers will meet the requirements of the base loads .

Taken together these results indicate that the coal gasification/combined cycle is technically feasible, within the state-of-the-art and can provide performance at the levels required for SPNC.

**SUMMARY OF COMMERCIALY AVAILABLE ENVIRONMENTAL
CONTROL PROCESSES**

<u>Coal Storage, Treatment and Processing</u>	<u>Gasification</u>	<u>Gas Purification</u>	<u>Gas Turbines</u>
Baghouses	Covered coal transport	Particulate Control Baghouses	Water Injection
Water or Oil Sprays	Feed controls	Cyclones	Steam Injection
Leachate Capture	Ash controls as in tradi- tional boilers.	Electrostatic Precipitators	
Covered Conveyors		Gas Quenching Controls	
Collection Hoods and Ducts		Flocculation/filtration	
		Oil-water separators	
		Extraction	
		Absorption	
		Biological oxidation	
		Acid Gas Controls	
		Rectisol	
		Selexol	
		Purisol	
		MEA	
		MDEA	
		Benfield	
		Amisol	
		Sulfinol	
		Claus	
		Stretford	

INTEGRATED COMBINED CYCLE
PERFORMANCE SUMMARY

	<u>Lurgi</u>	<u>Woodall- Duckham</u>	<u>Wellman-³ Galusha</u>	<u>Winkler</u>	<u>Koppers- Totzek</u>	<u>Texaco</u>
Energy Input (10^6 Btu/hr)	899	958	962	1,070	902	865
Annual Coal Use (tons) ¹	320,400	341,400	342,800	381,300	321,500	308,300
Net Electric Generated (MW)	57.0	56.9	61.0	58.4	57.1	56.2
Net Export Steam Flow (lb/hr) ²	221,500	274,600	274,200	325,300	321,100	330,100
Thermal-to-Electric Ratio	1.37	1.70	1.61	1.97	1.98	2.07
Overall Efficiency (%)	51	54	55	55	64	68
Heat Rate (Btu/kWh)	6,690	6,320	6,210	6,210	5,330	5,020

NOTES:

1. Standard coal at 12,290 Btu/lb; 100% availability.
2. Includes by-products, tar and oil, fired in a boiler at 340 psig, saturated.
3. Air-blown gasifier.

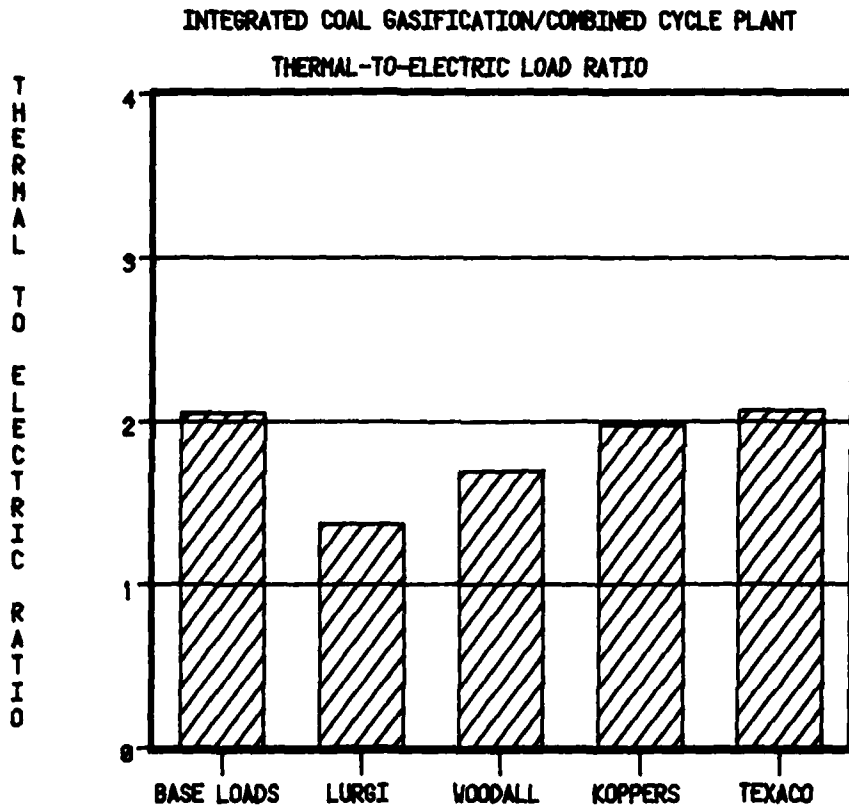

SUMMARY OF CONVENTIONAL TECHNOLOGY ANALYSES

To provide a convenient comparison to the integrated coal gasification/combined cycle power plant a conventional coal-fired steam plant with back pressure steam turbine generator was assessed for SPNC.

Boilers considered included:

- pulverized coal system installed in the existing plant with wet or dry scrubbing for environmental control.
- stoker systems again with either wet or dry scrubbing.
- fluidized bed boilers operated with limestone for sulfur capture and baghouses for particulate capture.

The major considerations focused on appropriate sizing of the components. For purposes of the feasibility study we assumed that the performance of the boilers are all similar; consider, then, the results in Exhibit 12. Here we provide the outputs of the system with two potential scales. These results are compared economically to each other and to the cg/cc later.

ECONOMIC RESULTS

Before providing the results from the economic analysis it is pertinent first to introduce two critical elements of the effort: the utility interface and the escalation and discount rates.

The attitude of the local utility, Virginia Electric Power Company (VEPCO) toward SPNC cogeneration, with its financial and economic requirements and with the important effects of the Public Utilities Regulatory Policy Act of 1978 (PURPA) is one of positive cooperation in the implementation of such schemes. This cooperation includes a willingness to joint venture with the U.S. Navy or a third-party in implementing the project. Furthermore, a new rate structure for cogeneration has been established. Comparison of the existing rate structure at SPNC with this new one is shown in Exhibit 13; cogeneration is well served.

Since this study was performed under funding from NAVFAC and U.S. DOE escalation advice was employed from both agencies. Their comparison is shown in Exhibit 14. Some of the important differences between these two escalation scenarios require comment:

- DOE does not employ short term escalation rates; analyses are to be carried out on a constant dollar, in this case 1981 basis. NAVFAC uses as its base the first year of operations, in this case 1988, and prescribes short term escalation rates for inflating current, 1981, costs to 1988.

SUMMARY OF RESULTS FOR BACK PRESSURE TURBINE OPERATION

<u>Size (lb/hr)</u>	<u>No. of Boilers</u>	<u>Turbine Size (kW)</u>	<u>Power Produced (10⁶ kWh/yr)</u>	<u>Steam Produced (10⁹ lb/yr)</u>	<u>Steam¹ Export (10⁹ lb/yr)</u>	<u>Coal^{2,3} Consumption (tons/yr)</u>
225,000	1	5,000	41.5	2.0	1.4	95,300
200,000	3	13,000	88.4	4.2	3.0	203,100

NOTES:

1. Steam export accounts for internal plant use for feedwater heating as compared to steam produced.
2. Standard coal at 12,290 Btu/lb, 100% availability.
3. These results are equivalent to an overall efficiency of 82% or a heat rate of 4,150 Btu/kWh.

COMPARISON OF VEPCO RATE SCHEDULES

	<u>Existing</u>	<u>New Cogeneration</u>
Demand Charge	\$6.22/kW with an eleven month ratchet	\$4.22/kW, average, with no ratchet
Energy Charge	\$0.01546/kWh	\$0.0349/kWh, average
Fuel Adjustment	Recent price is approximately \$0.03/kWh	None
Day of Time Rates	No	Yes
Electric Purchases by VEPCO from co-generator	None	\$0.0329/kWh, average

COMPARISON OF ESCALATION RATES

<u>U.S. NAVY</u>		
Discount Rate 10%		
	<u>Short Term</u> <u>Escalation Rates</u>	<u>Long Term Differential</u> <u>Escalation Rates*</u>
Operations and Maintenance	5.6%	0.0%
Oil	14.0%	8.0%
Coal	10.0%	5.0%
Electric	14.0%	7.0%

U.S. DOE - Industrial Rates, Region 3, Virginia
Discount Rate 7%

	<u>Long Term Differential Escalation Rates* -</u>		
	<u>U.S. Average</u>		
	<u>1980 - 1985</u>	<u>1985 - 1990</u>	<u>1990 and Beyond</u>
Operations and Maintenance	0.0%	0.0%	0.0%
Residual Oil	7.53%	2.58%	4.28%
Coal	9.63%	1.97%	1.12%
Electric	-0.01%	1.19%	-0.50%

*Differential escalation rates are defined to be those above (or below) inflation.

- There are significant differences between the long term differential rates.
- NAVFAC uses a discount rate of 10%; DOE uses 7%.

The first of these differences makes it impossible to compare results. We have, therefore, established a self-consistent set of short term DOE escalations by adding an assumed, constant inflation of 8% to their differential values. This then permits escalation to 1988. In terms of life cycle methodology, it should also be noted that DOE indicates that a project is economically effective if the savings/investment ratio is greater than 1, a measure not generally acceptable to the Navy. Similarly, the DOE methodology requires that an economically effective project have a simple payback period only "significantly less" than the project life; much shorter payback periods are required by the Navy.

Now consider the results. Preliminary economic analysis indicated that both the Wellman-Galusha and Winkler gasifiers should not be given detailed consideration: the former because of its only limited oxygen-blown, medium-Btu gas experience, the latter because of its unsuitably large scale.

Detailed life cycle costing of the other four gasifiers/combined cycle configurations were carried out. Results under NAVFAC escalation are shown in Exhibit 15.

To carry out the remaining analyses and since there are only small differences between the systems, we focus our attention on Texaco as representative. Additional detail is provided in Exhibit 16, now for both NAVFAC and DOE escalation rates. Because of the differences in discount rates, we include calculations for return on equity which provide a reasonable comparative base for the two scenarios. The economic returns here are excellent and independent of escalation.

The practicality of gasification at all is a question which must be addressed. From Exhibit 17, for the two discount rates and a range of gasifier costs, we see that natural gas cost need be much lower than current values to degrade the economic results.

For comparative purposes, we note here the life cycle results for the conventional cycle. With an investment of \$40.5 million (1981), and providing 225,000 lb/hr of steam and 5 MW of back pressure turbine electric generation, discounted payback periods of 2.44 years obtain under NAVFAC escalation and 2.39 years under DOE escalations. Note that the ECR for this project is 1.7, considerably less than for the cg/cc.

LIFE CYCLE COST ANALYSIS
 INTEGRATED COMBINED CYCLE/GASIFICATION
 VS. CONTINUED OPERATION OF OIL PLANT

(NAVFAC ESCALATION)

	<u>Lurgi</u>	<u>Woodall- Duckham</u>	<u>Koppers- Totzek</u>	<u>Texaco</u>
Investment	226,700	229,400	243,000	243,000
Total Life Cycle Savings	1,122,120	1,188,920	1,290,440	1,302,270
Savings - Investment Ratio	4.95	5.18	5.31	5.36
Discounted Payback Period (Years)	4.48	4.24	4.06	4.05
Energy Cost Rates (ECR) (10 ⁶ Btu/10 ³ Investment)	3.9	4.3	7.2	8.3

1. All dollars are in 1988 in 1000's.

LIFE CYCLE COST ANALYSIS
 INTEGRATED COMBINED CYCLE/GASIFICATION
 ESCALATION RATE COMPARISON
 (100% EQUITY)

	<u>NAVFAC Rates</u>	<u>DOE Rates</u>
Investment	243,000	263,200
Annual Coal Savings	(22,480)	(29,360)
Annual Electric Savings	51,460	38,740
Annual G&M Savings	(5,650)	(6,620)
Annual Oil Savings	37,880	36,470
Total Life Cycle Savings	1,302,270	621,350
Savings Investment Ratio	5.36	2.62
Discounted Payback Period	4.05	7.18
ECR (10^6 Btu/ 10^3 Investment)	8.3	7.6
Return on Equity	39.8	19.4

 1. All dollars are in 1988 in 1000's.

EFFECT OF COAL GASIFICATION COSTS
25 YEAR LIFE CYCLE EVALUATION

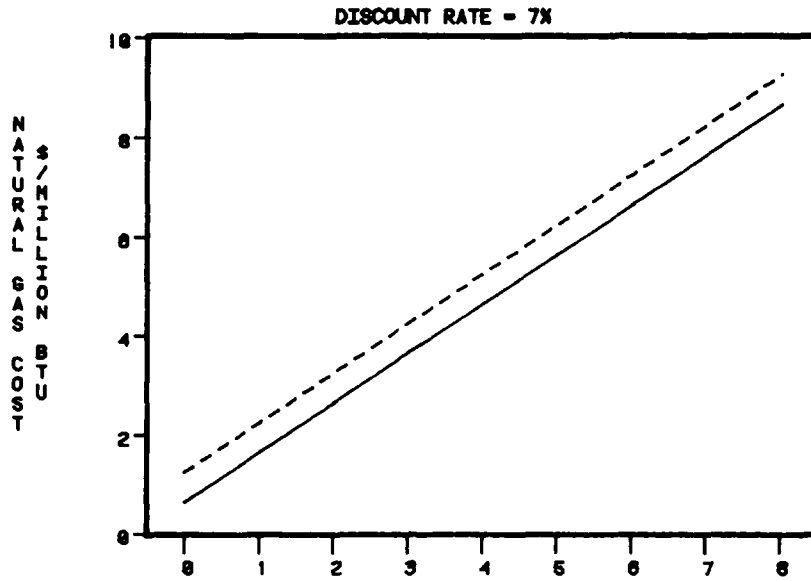

UNIT INVESTMENT COST
——— \$10/MILLION BTU
- - - - \$20/MILLION BTU

COAL COST (\$/MILLION BTU)

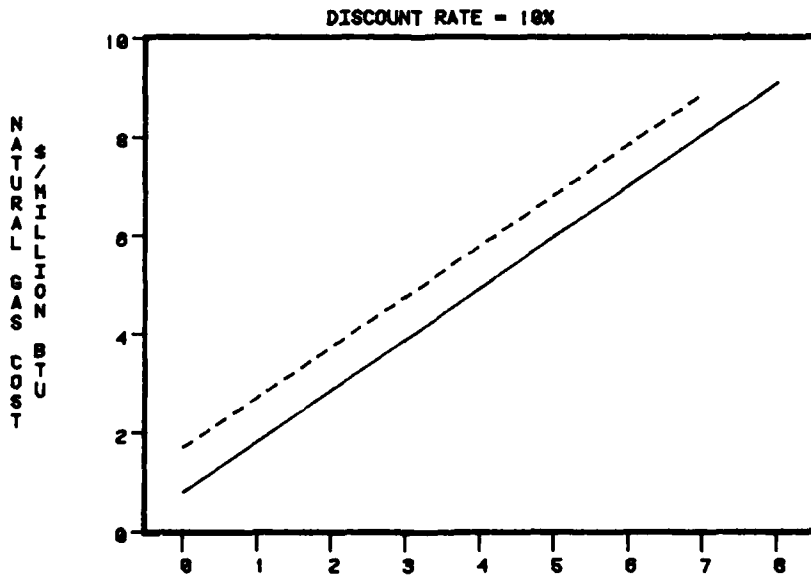

UNIT INVESTMENT COST
——— \$10/MILLION BTU
- - - - \$20/MILLION BTU

COAL COST (\$/MILLION BTU)

NATIONAL APPLICABILITY

In light of the excellent economics for the cg/cc, we must ask if such a cycle has national applicability. Investigation of the energy consumption of various industries indicated several that have appropriate loads and scale for such a plant. Energy consumption and potential oil savings for some of these are shown in Exhibit 4. These results indicate that broad based implementation of a coal gasification/combined cycle can yield annual savings of over 260 million barrels of oil per year.

Thus it appears that, with appropriately chosen industries, there exists a large potential market for such systems. This, in addition to the impetus provided by investment and energy tax credits and new and accelerated depreciation rates -- actions taken nationally to encourage private investment in the energy sector -- indicates that there exists opportunity for third-party implementation of the needed plant at SPNC.

In Exhibit 3 we suggested the value to both NAVFAC and the third-party of such a scheme. Analysis of these results suggests that:

- the Navy would save over \$780 million during the course of a 15-year lease compared to current oil firing.
- the private investor could realize return on equity approaching 20%, well within traditional guidelines for investment opportunities.
- the Navy would realize these savings without actually having to undertake the system investment or appropriation.
- such a program would be in complete concert with current Administration goals of increasing private sector investment, shifting toward coal and relying on the marketplace to initiate moves toward a viable synthetic fuel industry.

These results together then lead to the recommendations cited earlier:

- cogeneration at SPNC be pursued immediately.
- coal gasification/combined cycle be the technology employed at SPNC.
- the private sector be actively solicited for third-party financing, design and construction.

END

DATE
FILMED

10-81

DTIC