

AD-A103 771 FOREIGN TECHNOLOGY DIV WRIGHT-PATTERSON AFB OH  
OPTICAL CORRELATOR, (U)  
AUG 81 V P IVANCHENKOV, P A DYUGAY

F/6 20/6

UNCLASSIFIED FTD-ID(RS)T-0554-81

NL

1 of 1  
414  
013



END  
DATE  
FILMED  
10-81  
DTIC

2

FTD-ID(RS)T-0554-81

AD A103771

# FOREIGN TECHNOLOGY DIVISION



OPTICAL CORRELATOR

by

V. P. Ivanchenkov and P. A. Dyugay

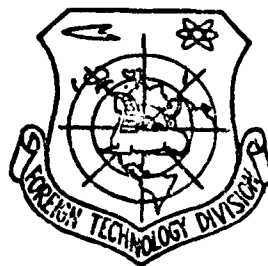

SECRET  
314

Approved for public release;  
distribution unlimited.



DIC FILE COPY

81 9 02 035

# UNEDITED MACHINE TRANSLATION

(14) FTD-ID(RS)T-0554-81 (11) 18 Aug 1981

MICROFICHE NR: FTD-81-C-000736

(6) OPTICAL CORRELATOR

By (10) V. P. /Ivanchenkov and P. A. /Dyugay

(21) English pages: 9  
Unedited machine translation  
Source: ~~USSR~~ Patent # 328479, February 1972 p. 1-4, 2 Feb 72.

Country of origin: (USSR)  
This document is a machine translation  
Requester: USAMICOM/DRSMI-YDL  
Approved for public release; distribution unlimited.

(12) 12

<p>THIS TRANSLATION IS A RENDITION OF THE ORIGINAL FOREIGN TEXT WITHOUT ANY ANALYTICAL OR EDITORIAL COMMENT. STATEMENTS OR THEORIES ADVOCATED OR IMPLIED ARE THOSE OF THE SOURCE AND DO NOT NECESSARILY REFLECT THE POSITION OR OPINION OF THE FOREIGN TECHNOLOGY DIVISION.</p>	<p>PREPARED BY: TRANSLATION DIVISION FOREIGN TECHNOLOGY DIVISION WP-AFB, OHIO.</p>
---	--

U. S. BOARD ON GEOGRAPHIC NAMES TRANSLITERATION SYSTEM

Block	Italic	Transliteration	Block	Italic	Transliteration
А а	<i>А а</i>	A, a	Р р	<i>Р р</i>	R, r
Б б	<i>Б б</i>	B, b	С с	<i>С с</i>	S, s
В в	<i>В в</i>	V, v	Т т	<i>Т т</i>	T, t
Г г	<i>Г г</i>	G, g	У у	<i>У у</i>	U, u
Д д	<i>Д д</i>	D, d	Ф ф	<i>Ф ф</i>	F, f
Е е	<i>Е е</i>	Ye, ye; E, e*	Х х	<i>Х х</i>	Kh, kh
Ж ж	<i>Ж ж</i>	Zh, zh	Ц ц	<i>Ц ц</i>	Ts, ts
З э	<i>З э</i>	Z, z	Ч ч	<i>Ч ч</i>	Ch, ch
И и	<i>И и</i>	I, i	Ш ш	<i>Ш ш</i>	Sh, sh
Й й	<i>Й й</i>	Y, y	Щ щ	<i>Щ щ</i>	Shch, shch
К к	<i>К к</i>	K, k	Ъ ъ	<i>Ъ ъ</i>	"
Л л	<i>Л л</i>	L, l	Ы ы	<i>Ы ы</i>	Y, y
М м	<i>М м</i>	M, m	Ь ь	<i>Ь ь</i>	'
Н н	<i>Н н</i>	N, n	Э э	<i>Э э</i>	E, e
О о	<i>О о</i>	O, o	Ю ю	<i>Ю ю</i>	Yu, yu
П п	<i>П п</i>	P, p	Я я	<i>Я я</i>	Ya, ya

\*ye initially, after vowels, and after ь, ь; e elsewhere.  
When written as ë in Russian, transliterate as yë or ë.

RUSSIAN AND ENGLISH TRIGONOMETRIC FUNCTIONS

Russian	English	Russian	English	Russian	English
sin	sin	sh	sinh	arc sh	sinh <sup>-1</sup>
cos	cos	ch	cosh	arc ch	cosh <sup>-1</sup>
tg	tan	th	tanh	arc th	tanh <sup>-1</sup>
ctg	cot	cth	coth	arc cth	coth <sup>-1</sup>
sec	sec	sch	sech	arc sch	sech <sup>-1</sup>
cosec	csc	csch	csch	arc csch	csch <sup>-1</sup>

Russian	English
rot	curl
lg	log

Accession For	
NTIS GRA&I	<input checked="" type="checkbox"/>
DTIC TAB	<input type="checkbox"/>
Unannounced	<input type="checkbox"/>
Justification	
By _____	
Distribution/	
Availability Codes	
Dist	Avail and/or Special
<i>A</i>	

Page 1.

OPTICAL CORRELATOR.

V. P. Ivanchenkov and P. A. Dyugay.

Invention relates to the informational technology, in which the extraction of essential signs/criteria from the image and the comparison of these signs/criteria with the placed in the memory information is realized with the aid of optical type correlators, for example, in the navigational devices, in the character readers, etc.

Are known the devices/equipment, which make it possible to distinguish at a high speed of image on the base of the principles of optical correlation. One of the fundamental elements/cells of such devices/equipment are the breeders of images, which convert the image being investigated into many identical copies. In such devices/equipment the multiplication is realized with the aid of the mosaic of the lenses of fiber converter, system of semitransparent mirrors or prisms.

However, the manufacture of these devices/equipment requires the high labor input, use/application of a large quantity of lenses, mirrors, prisms, which substantially complicates the construction/design of optical correlator, increases its weight, overall sizes and cost/value.

For the purpose of simplification in the diagram of the optical correlator, which contains a breeder image, increases in the operating speed of the reading of information and improvement in the quality of the reproduction of the image being investigated in the proposed correlator is changed optically opaque transparency with the group of narrow holes that it makes it possible to for go the use of a fiber converter, complicated mosaic of lenses, mirrors, prisms. The manufacture of this breeder differ significantly from the the noted for low labor expense. The greatest value of signal, proportional to the cross-correlation function of the compared images, is isolated in the system with the aid of parallel type simple high speed diagram.

Fig. 1 shows the block diagram of optical correlator; in Fig. 2 - the diagram, which elucidates the principle of the multiplication of the shape being investigated and in Fig. 3 - the schematic diagram of the block of making decisions.

Optical type proposed correlator consists of device/equipment 1

of reproduction of the image being investigated, breeder 2, which represents transparency with the group of narrow holes, the storage part of device/equipment 3, of which is preliminarily carried certain number of test patterns, the unit of photosensitive devices 4, which consists of the matrix/die of photodiodes, for example type PD-3 whose number is equal to a quantity of test patterns, unit of making decisions of 5, which indicates the class to which belongs the shape being investigated, and tape-drive mechanism 6.

Page 2.

The method of pattern recognition is based on setting of the correlation evaluations/estimates of the similarity of the compared images.

With the aid of the device/equipment of reproduction 1 the shape being investigated is projected/designed for breeder 2, with the aid of which we obtain many identical copies. The comparison of the copies of the investigated shape with entire set of standard ones, stored in the storage part of correlator 3, is realized with the aid of the radiant flux from the illuminator on the incandescent lamp, passing through each pair of compared images. The computation of the cross-correlation functions of the shape being investigated with entire multitude of standard ones for each fixed/recorded position of

shape is realized virtually instantly. With the coincidence of the shape being investigated with one of the standards the cross-correlation function takes the greatest value, and the signal, taken from the appropriate diode of matrix/die, proportional to the value of correlation function, is maximum.

As the breeder of images is utilized optically opaque transparency with the group of narrow holes.

The principle of breeding of images with the aid of the optically opaque transparency with the circular structure is explained by Fig. 2. Number of holes in the transparency is selected equal to a quantity of memorized test patterns. The use/application of this breeder significantly simplifies the diagram of correlator, its manufacture in practice does not distort the image of the shape being investigated, which with difficulty is achieved (by the complication of optical system) by the use of the highest-quality lenses and mirrors.

The optical channel of correlator, which switches on device/equipment 1 of reproduction of the shape being investigated, breeder 2, storage part of device/equipment 3, can be realized on one of the following functional diagrams.

The first version - lensless, when light source flow falls directly on the film from the shape being investigated. With the aid of the transparency the shape being investigated is multiplied to the identical copies and in the storage part of the device/equipment is compared with entire multitude of the memorized shapes.

Second version - optical channel of correlator with condensing lens, placed before the breeder and which makes it possible easily to scale of the image of the shape being investigated in datum plane.

The third version when transparency 2 for multiplying the image is placed directly before the radiation source, and shape being investigated after condensing lens.

For recognition of the moving/driving shapes in the correlator is provided the tape-drive mechanism, which consists of two carriages, reducer, electric motor 7 reference generator 8. During the motion of film the signals from the matrix/die of photodiodes reach maximum value when the displacement of the shape being investigated relative to standard along the axis of displacement is absent, the identification of the shape being investigated is conducted on the base of the determination of the maximum of the signals, carried into storage cell of the unit of accepting the solutions (see Fig. 1) on one of the algorithms of blind search. The

diagram, which realizes this algorithm is simple, it possesses the large operating speed (see Fig. 3) and consists of storage cells on capacitors 9, logic circuit, carried out on diodes 10, and peak transformers 11, for example type MIT-2, the key/wrench of demand 12, amplifier-limiter 13, Schmidt flip-flop 14 and keys/wrenches of reset 15. Signals with the matrix/die of photosensitive devices, the proportional to crosscorrelation function of the compared shapes, will be brought in into storage cells 9, to each of which is set in the conformity the completely specific shape. When the displacement of shape is absent to electronic gate 12 it falls the impulse/momentum/pulse of negative polarity from amplifier-limiter 13.

Joining to the center of the frame of the shape being investigated at the moment of the absence of displacement is realized with the aid of the generator of 8 reference voltages, connected with the shaft of the electric motor of 7 tape-drive mechanisms 6 (see Fig. 1 and 3).

Voltage frequency is matched with the frame dimension and the rate of broach. The negative pulse (interrogation pulse), which enters key/wrench 12, switches logic circuit on diodes 10 and transformers of 11 isolations/liberations of maximum. Current flows/occurs/lasts only through that diode of logic circuit which is

connected to the cell with the greatest signal. As a result at the output to this corresponding diode of peak transformer appears the current pulse which enters the diagram of the indication (or recording) of the identified shape. In connection with the fact that the isolation/liberation of peak signal from all storage cells is conducted simultaneously (in parallel) virtually it is eliminated the error, caused by the similarity of the identified shapes (signs). Reset of capacitors 9 for each shape being investigated during the motion of tape is realized by means of the time delay of the reset pulse, taken from Schmitt trigger, relative to interrogation pulse. Time delay is determined by the selection of the level of the operation of the Schmitt trigger and is selected smaller fourth it is temporary/time the passage of film on the shape being investigated.

Reset pulse from Schmitt trigger enters keys/wrenches 15 and it gives storage cells to the initial position.

Page 3.

The mock-up of the proposed device/equipment showed complete efficiency at the rate of tape handling to 200 shapes per minute.

Object/subject of invention.

1. Optical correlator, which contains device/equipment of reconstruction of image, optically connected with breeder of images, storage device/equipment, connected with unit of photosensitive devices by that connected to unit of making decisions connected through reference generator with tape-drive mechanism, which is characterized by fact that, for purpose of simplification in correlator, in it breeder of images is carried out in the form of optically opaque transparency with group of openings/apertures.

2. Device/equipment in p. 1, which differs in terms of fact that, for purpose of increase in operating speed during identification of moving/driving images, in it unit of making decisions is carried out in the form of parallel structure, which contains in each channel electronic gate with input holding capacitor, overall multi-input diagram of isolation/liberation of maximum with key/wrench of request, connected amplifier-limiter, connected to Schmitt trigger and to reference generator.

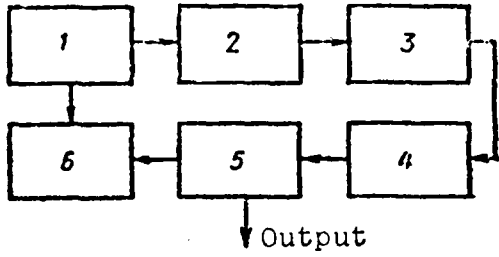

Fig. 1.

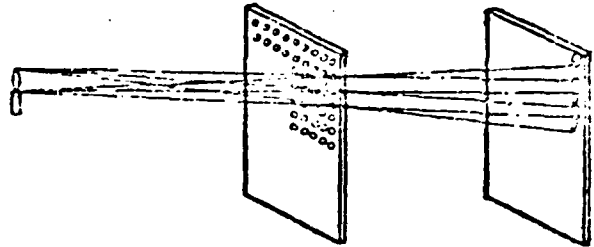

Fig. 2.

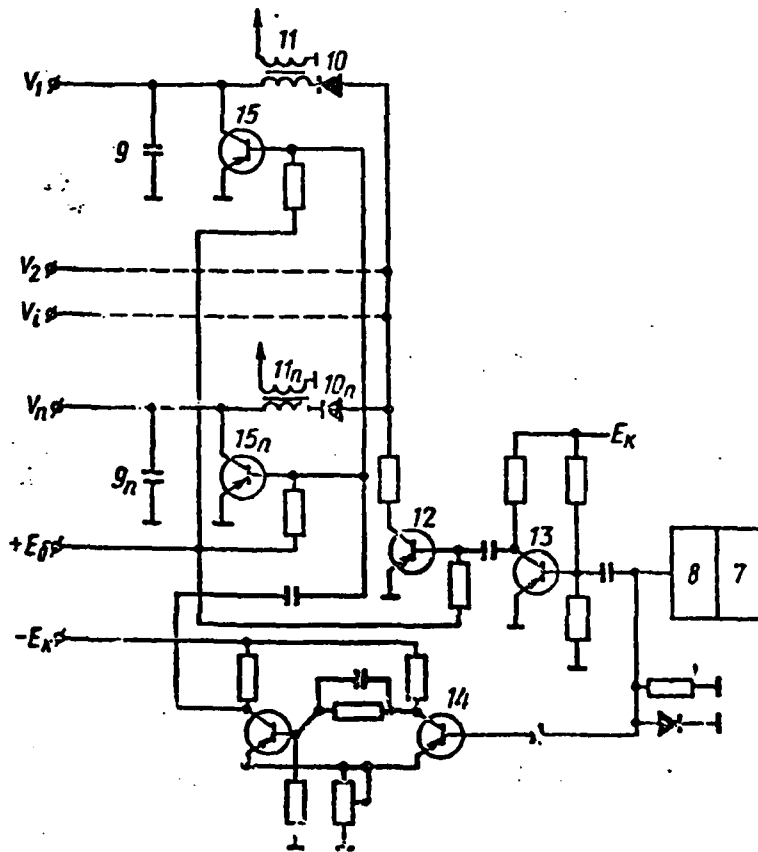

Fig. 3.

DATE  
ILMED  
- 8