

AD A 103788

DWG FILE COPY

81 9 03 066



1-2-FA/CA
11/18/81

12



ENVIRONMENTAL PROTECTION AGENCY/
CORPS OF ENGINEERS
TECHNICAL COMMITTEE ON CRITERIA
FOR DREDGED AND FILL MATERIAL

PROCEDURES FOR HANDLING AND CHEMICAL ANALYSIS
OF SEDIMENT AND WATER SAMPLES.

by

10 Russell H. Plumb, Jr.
Great Lakes Laboratory
State University College at Buffalo
1300 Elmwood Avenue
Buffalo, New York 14222

May 1981

11

12 1544

DTIC
SERIALS
SEP 3 1981
A

15 EPA-48-15-5700-10

This document has been approved
for public release and sale; its
distribution is unlimited.

Prepared for U.S. Environmental Protection Agency/Corps of
Engineers Technical Committee on Criteria
for Dredged and Fill Material

Under Contract EPA-4805572010

Monitored by Large Lakes Laboratory
U.S. Environmental Protection Agency
9311 Groh Road
Grosse Ile, Michigan 48138

Published by Environmental Laboratory
U.S. Army Engineer Waterways Experiment Station
P.O. Box 631, Vicksburg, Mississippi 39180

46

413
GME

Destroy this report when no longer needed. Do not return
it to the originator.

The findings in this report are not to be construed as an official
Department of the Army position unless so designated
by other authorized documents.

The contents of this report are not to be used for
advertising, publication, or promotional purposes.
Citation of trade names does not constitute an
official endorsement or approval of the use of
such commercial products.

PREFACE

This project was supported by Grant EPA-4805572010 between the Environmental Protection Agency and the Research Foundation of the State University of New York. Funding for this project was equally shared between the U. S. Environmental Protection Agency and the U. S. Army Engineer Waterways Experiment Station. The objective of the effort was to prepare a procedures manual that will contain summaries and descriptions of the tests, sample collection and preservation procedures, analytical procedures, and calculations required for the evaluation of Section 404 permits as specified in Public Law 92-500.

This work was conducted during the period March 1978 - March 1980 by the Great Lakes Laboratory (GLL), State University College of New York at Buffalo, Buffalo, New York. The investigation was conducted by Dr. Russell H. Plumb, Jr., Associate Director, GLL. The study was under the general supervision of Dr. Robert A. Sweeney, Director, GLL.

The contract was monitored by Mr. Jim Westhoff and Dr. Robert M. Engler of the Environmental Laboratory (EL), U. S. Army Engineer Waterways Experiment Station, Vicksburg, Mississippi; and Dr. Michael D. Mullin, U. S. Environmental Protection Agency, Grosse Ile Laboratory, Grosse Ile, Michigan. Directors of WES during the conduct of this study and preparation of this manual were COL J. L. Cannon, CE, and COL N. P. Conover, CE. Technical Director was Mr. F. R. Brown.

This report should be cited as follows:

Plumb, R. H., Jr. 1981. "Procedure for Handling and Chemical Analysis of Sediment and Water Samples," Technical Report EPA/CE-81-1, prepared by Great Lakes Laboratory, State University College at Buffalo, Buffalo, N. Y., for the U. S. Environmental Protection Agency/Corps of Engineers Technical Committee on Criteria for Dredged and Fill Material. Published by the U. S. Army Engineer Waterways Experiment Station, CE, Vicksburg, Miss.

ion For	
GFA&I	<input checked="" type="checkbox"/>
AB	<input type="checkbox"/>
nced	<input type="checkbox"/>
ocation	<input type="checkbox"/>
ion/	
Availability Codes	
Avail and/or	
Dist	Special
A	

Handwritten notes and signatures are present over the form, including "50 Feb" and a signature.

TABLE OF CONTENTS

	<u>Page</u>
Preface	i
List of Tables	x
List of Figures	xii
Conversion Factors	xv
INTRODUCTION	1
SECTION 1: PROJECT MANAGEMENT GUIDANCE	1-1
Project Definition	1-2
Test Selection	1-3
Testing procedures	1-3
Chemical analyses	1-5
Sampling Considerations	1-5
Representative sampling	1-6
Sampling techniques selection	1-19
Sample preservation	1-22
Quality Control	1-24
Additional Considerations	1-25
Summary	1-26
References	1-27
SECTION 2: FIELD/LABORATORY GUIDANCE	2-1
Method of Sample Collection	2-1
Water samplers	2-2
Sediment samplers	2-3
Sample Collection	2-4
Sample Handling	2-11
Sample Preservation	2-15

	<u>Page</u>
Total Solids Procedure for Water Samples	3-56
Method 1: Gravimetric	3-56
Total Solids Procedure for Sediment Samples	3-58
Method 1: Gravimetric	3-58
Volatile Solids Determination	3-59
Specific Gravity	3-61
Procedure for Sediment Samples	3-61
Inorganic Analysis	3-64
Carbon, Total Organic and Inorganic	3-65
Procedure for Water Samples	3-69
Method 1: Infrared Analysis	3-69
Procedure for Sediment Samples	3-73
Method 1: Sample Ignition	3-73
Method 2: Differential Combustion	3-74
Metals (Al, Cd, Ca, Cr, Cu, Fe, Pb, Mg, Mn, Mo, Ni, Zn)	3-77
Procedure for Water Samples (All metals except As, Hg, and Se)	3-80
Method 1: Direct Flame Atomic Absorption, Total Metals	3-80
Method 2: Direct Flame Atomic Absorption, Soluble Metals	3-85
Method 3: Graphite Furnace Atomic Absorption	3-89
Method 4: Chelation-Extraction Atomic Absorption	3-93
Procedure for Sediment Samples (All metals except As, Hg, and Se)	3-96
Method 1: Direct Flame Atomic Absorption, Total Metals	3-96
Metals (Arsenic)	3-110
Procedure for Water Samples	3-110
Method 1: Arsine Generation	3-110
Method 2: Graphite Furnace	3-114

	<u>Page</u>
Procedure for Sediment Samples	3-116
Method 1: Arsine Generation	3-116
Metals (Mercury)	3-118
Procedure for Water Samples	3-118
Method 1: Cold Vapor Technique	3-118
Procedure for Sediment Samples	3-124
Method 1: Cold Vapor Technique	3-124
Metals (Selenium)	3-127
Procedure for Water Samples	3-127
Method 1: Hydride Generation	3-127
Procedures for Sediment Samples	3-131
Method 1: Digestion/Flameless Atomic Absorption	3-131
Method 2: Hydride Generation	3-133
Nitrogen (Ammonia, Nitrate, Nitrite, Total Kjeldahl, Organic)	3-138
Nitrogen (Ammonia)	3-140
Procedures for Water Samples	3-140
Method 1: Colorimetric, Automated Phenate	3-140
Method 2: Colorimetric, Automated O-Tolidine	3-144
Method 3: Colorimetric or Titrimetric, Manual	3-148
Procedures for Sediment Samples	3-154
Method 1: Potassium Chloride Extraction	3-154
Method 2: Distillation	3-155
Method 3: Distilled Water Extraction	3-157
Nitrogen (Nitrate)	3-159
Procedures for Water Samples	3-159
Method 1: Colorimetric, Manual, Brucine Sulfate	3-159
Method 2: Colorimetric, Automated, Cadmium Reduction	3-163

	<u>Page</u>
Method 3: Colorimetric, Automated, Hydrazine Reduction	3-168
Method 4: Colorimetric, Manual, Cadmium Reduction	3-174
Nitrogen (Nitrite)	3-179
Procedures for Water Samples	3-179
Method 1: Colorimetric, Automated, Cadmium Reduction	3-179
Method 2: Colorimetric, Automated, Hydrazine Reduction	3-179
Method 3: Colorimetric, Manual, Cadmium Reduction	3-179
Method 4: Colorimetric, Manual	3-179
Procedure for Sediment Samples	3-183
Nitrogen (Total Kjeldahl)	3-185
Procedures for Water Samples	3-185
Method 1: Colorimetric, Semiautomated with Block Digestor	3-185
Method 2: Manual Colorimetric, Titrimetric	3-190
Method 3: Colorimetric, Automated Phenate	3-195
Procedures for Sediment Samples	3-201
Method 1: Kjeldahl Digestion	3-201
Method 2: Block Digestion	3-202
Nitrogen (Organic)	3-205
Phosphates (Soluble Reactive, Total, Organic)	3-207
Phosphates (Soluble Reactive)	3-212
Procedures for Water Samples	3-212
Method 1: Ascorbic Acid, Manual	3-212
Method 2: Ascorbic Acid, Automated	3-213
Method 3: Stannous Chloride, Manual	3-214
Method 4: Stannous Chloride, Automated	3-218
Method 5: Vanadomolybdophosphoric Acid, Manual	3-221
Procedure for Sediment Samples	3-223

	<u>Page</u>
Phosphates (Total)	3-225
Procedures for Water Samples	3-225
Procedures for Sediment Samples	3-227
Phosphates (Organic)	3-230
Procedures for Water Samples	3-230
Procedures for Sediment Samples	3-232
Method 1: Acid Hydrolysis	3-232
Method 2: Acid Extraction	3-233
Sulfides	3-236
Procedures for Water Samples	3-238
Method 1: Methylene Blue, Colorimetric	3-238
Method 2: Iodine Titrimetric	3-240
Procedure for Sediment Samples	3-243
Method 1: Distillation, Methylene Blue, Colorimetric	3-243
Organic Analysis	3-248
Carbamates	3-249
Procedure for Water Samples	3-249
Method 1: Methylene Chloride Extraction	3-249
Procedure for Sediment Samples	3-255
Method 1: Methylene Chloride Extraction	3-255
Chlorinated Phenoxy Acid Herbicides	3-260
Procedures for Water Samples	3-262
Method 1: Chloroform Extraction	3-262
Method 2: Ethyl Ether Extraction	3-265
Procedure for Sediment Samples	3-271
Method 1: Acetone-Hexane Extraction	3-271
Oil and Grease	3-278
Procedure for Water Samples	3-278
Method 1: Freon Extraction	3-278

	<u>Page</u>
Procedure for Sediment Samples	3-284
Method 1: Freon Extraction	3-284
Chlorinated Hydrocarbons	3-289
Procedures for Water Samples	3-291
Method 1: Benzene Extraction	3-291
Method 2: Methylene Chloride/Hexane Extraction	3-298
Procedures for Sediment Samples	3-307
Method 1: Acetone/Hexane Extraction	3-307
Method 2: Acetonitrile Extraction	3-313
Organophosphorous Pesticides	3-319
Procedure for Water Samples	3-321
Method 1: Hexane, Chloroform, Benzene Extraction	3-321
Procedure for Sediment Samples	3-332
Method 1: Hexane Extraction	3-332
Polynuclear Aromatic Hydrocarbons	3-337
Procedure for Water Samples	3-337
Method 1: Dichloromethane Extraction/Gas Chromatography	3-337
Procedures for Sediment Samples	3-341
Method 1: Methanol Extraction/UV Analysis	3-341
Method 2: Ethanol Extraction/ UV Spectrophotometry	3-344
Phenolics	3-348
Procedures for Water Samples	3-348
Method 1: Distillation, 4-aminoantipyrine Colorimetric	3-348
Method 2: Distillation, MBTH Colorimetric	3-352
Procedures for Sediment Samples	3-355
Method 1: Distillation, 4-aminoantipyrine Colorimetric	3-355

	<u>Page</u>
Method 2: MBTH Colorimetric	3-357
Miscellaneous Analysis	3-361
Chlorine Demand	3-362
Procedures for Water Samples	3-364
Procedures for Sediment Samples	3-368
Biochemical Oxygen Demand	3-373
Procedures for Water Samples	3-374
Procedures for Sediment Samples	3-380
Chemical Oxygen Demand	3-385
Procedures for Water Samples	3-387
Method 1: Low Level, 5 to 50 mg/l	3-387
Method 2: High Level, 50 to 800 mg/l	3-389
Procedure for Sediment Samples	3-393
Sediment Oxygen Demand	3-396
Procedure for Sediment Samples	3-397
Method 1: In Situ	3-397
Method 2: Laboratory	3-399

LIST OF TABLES

<u>No.</u>		<u>Page</u>
1-1	Analytical Costs by Parameter	1-12
1-2	Performance Requirements, Number of Samples Per Day Per Man	1-15
2-1	Operational Evaluation of Grab Samplers	2-5
2-2	Operational Suitability of Corers and Grab Samplers	2-9
2-3	Recommended Method of Sample Storage as a Function of Bulk Sediment Analyses to be Performed	2-14
2-4	Recommended Water Preservation Techniques	2-17
2-5	Ideal Control Activities for Documenting the Validity of Laboratory Data	2-23
3-1	Acceptable Test Procedures	3-6
3-2	Comparison of Scales Used to Report Particle-Size Results	3-30
3-3	Comparison of Particle-Size Distribution Analytical Methods	3-30
3-4	Data Tabulation for Sand-Size Fractions	3-37
3-5	Data Tabulation for Coulter Counter Results for Silt- and Clay-Sized Fractions	3-38
3-6	Maximum Sieve Loads on 8-in.-diam Sieves for 1-phi Intervals	3-42
3-7	Sampling Time Intervals for Pipet Analysis	3-45
3-8	Typical Particle-Size Distribution Data Sheet	3-46
3-9	Recommended Atomic Absorption Spectrophotometer Instrument Settings for Metal Analysis	3-87
3-10	Graphite Furnace Operating Conditions for Selected Metals	3-91
3-11	HNO ₃ -HCl Digestion	3-98
3-12	HNO ₃ Digestion	3-100
3-13	HNO ₃ -H ₂ O ₂ Digestion	3-101
3-14	Muffle Furnace Ignition	3-103
3-15	Low Temperature Ashing	3-104
3-16	HF-HClO ₄ -HNO ₃ Digestion	3-105
3-17	HF-HNO ₃ -HCl Digestion	3-106
3-18	Operating Characteristics for TKN AutoAnalyzer Manifold	3-189
3-19	Some N-methylcarbamates and Related Compounds	3-250
3-20	Retention Times of Various Organochlorine Pesticides Relative to Aldrin	3-297

<u>No.</u>		<u>Page</u>
3-21	Persistence of Chlorinated Hydrocarbon Pesticides in River Water in Terms of Percentage Recovery	3-306
3-22	Composition of Organophosphorous Nanogram Standard	3-323
3-23	Detection Limit for 14 Organophosphorous Pesticides in 1-l Water Samples	3-326
3-24	Retention Time and Peak Height Data for Organophosphorous Pesticides	3-329
3-25	Retention Time for Organophosphorous Compounds on OV-101/ OV-210 at 210°C	3-330

LIST OF FIGURES

<u>No.</u>		<u>Page</u>
1-1	Average concentration as a function of dredge penetration	1-21
2-1	Comparative methods of sediment sample handling	2-13
2-2	Elemental partitioning procedure for sediment characterization	2-39
2-3	Sediment sample splitting for bulk analysis	2-42
3-1	Schematic of generalized sample handling procedure	3-3
3-2	Handling and storage procedures for cation exchange capacity samples	3-22
3-3	Handling and storage procedures for particle-size samples	3-32
3-4	Particle-size procedure using sieving/pipet analysis	3-41
3-5	Handling and storage procedures for total and volatile solids samples	3-55
3-6	Handling and storage procedures for total inorganic carbon samples	3-66
3-7	Handling and storage procedures for total organic carbon samples	3-67
3-8	Handling and storage procedures for metals samples	3-79
3-9	Hydride generator for arsenic and selenium analysis	3-111
3-10	Handling and storage procedures for mercury samples	3-119
3-11	Schematic cold vapor apparatus for mercury	3-120
3-12	Handling and storage of samples for ammonia analysis	3-141
3-13	AAI manifold for phenate determination of ammonia	3-145
3-14	AAII cartridge for phenate determination of ammonia	3-146
3-15	AA manifold for the O-tolidine determination of ammonia	3-149
3-16	Handling and storage of samples for nitrate analysis	3-160
3-17	Copper cadmium reduction column	3-165
3-18	AAI manifold for nitrate determination following cadmium reduction	3-167
3-19	AAII cartridge for the determination of nitrate following cadmium reduction	3-169
3-20	AAI manifold for the determination of nitrate following hydrazine reduction	3-172
3-21	AAII cartridge for the determination of nitrate following hydrazine reduction	3-173

<u>No.</u>		<u>Page</u>
3-22	Nitrate reduction column	3-175
3-23	Handling and storage of samples for nitrite analysis	3-180
3-24	Handling and storage of samples for TKN analysis	3-186
3-25	AAII cartridge for ammonia determinations with TKN digests	3-187
3-26	AAI manifold 1 for the determination of total Kjeldahl nitrogen	3-198
3-27	AAI manifold 2 for the determination of total Kjeldahl nitrogen	3-199
3-28	Continuous digester for the automated determination of total Kjeldahl nitrogen	3-200
3-29	Handling and storage of samples for orthophosphate analysis	3-209
3-30	Handling and storage of samples for organic phosphate analysis	3-210
3-31	Handling and storage of samples for total phosphate analysis	3-211
3-32	AAI manifold for the ascorbic acid determination of phosphorus	3-215
3-33	AAII cartridge for the ascorbic acid determination of phosphorus	3-216
3-34	Stannous chloride manifold for the determination of phosphorus, low level	3-219
3-35	Stannous chloride manifold for the determination of phosphorus, high level	3-220
3-36	Handling and storage of samples for sulfide analysis	3-237
3-37	Handling and storage of samples for carbamate analysis	3-251
3-38	Handling and storage of samples for chlorophenoxy acetic acid analysis	3-261
3-39	Handling and storage of samples for oil and grease analysis	3-279
3-40	Handling and storage of samples for chlorinated hydrocarbon analysis	3-290
3-41	Handling and storage of samples for organophosphate analysis	3-320
3-42	Handling and storage of samples for polynuclear aromatic hydrocarbon analysis	3-338
3-43	Handling and storage of samples for phenol analysis	3-349

<u>No.</u>		<u>Page</u>
3-44	Handling and storage of samples for chlorine demand analysis	3-363
3-45	Handling and storage of samples for biological oxygen demand analysis	3-375
3-46	Handling and storage of samples for chemical oxygen demand analysis	3-386
3-47	In situ sediment oxygen demand chamber	3-398
3-48	Laboratory sediment oxygen demand chamber	3-400

CONVERSION FACTORS, U. S. CUSTOMARY TO METRIC (SI)
UNITS OF MEASUREMENT

U. S. customary units of measurement used in this report can be converted to metric (SI) units as follows:

<u>Multiply</u>	<u>By</u>	<u>To Obtain</u>
feet	0.3048	meters
gallons (U. S. liquid)	3.785412	cubic decimeters
inches	25.4	millimeters
miles (U. S. statute)	1.609347	kilometers
pounds (mass)	0.4535924	kilograms
square miles	2.589998	square kilometers

↓

INTRODUCTION

1. The purpose of this handbook is to provide state-of-the-art guidance on the subjects of sampling, preservation, and analysis of dredged and fill material. This need developed as a result of the promulgation and implementation of Section 404(b) of Public Law (PL) 92-500 (Federal Water Pollution Control Act Amendments of 1972) which required the ecological evaluation of proposed dredging and filling operations as they may impact navigable waters of the United States. It is expected, therefore, that this manual will receive wider usage as an aid in the regulatory process rather than a research tool.

B The initial guidance for implementing Section 404(b) was released in 1976.¹ The guidance presented in this handbook should be viewed as second-generation Interim Guidance in the continuing process of procedure development, refinement, and evaluation. Thus, it will be intermediate between the initial Interim Guidance and analytical compendiums such as Standard Methods,² American Society of Testing and Materials (ASTM) manuals,³ or Environmental Protection Agency (EPA) manuals.⁴ The major emphasis of this effort has been to provide guidance on the subjects of sampling, sample handling, and sample pretreatment.

A 3. Three approaches were used to obtain the information required to prepare this manual. They were:

- a. Review published literature on sediment sampling and analysis.
- b. Contact personnel at several laboratories that are active in the field of sediment investigation:
 - (1) U. S. Environmental Protection Agency (EPA) Research Laboratories
 - (2) U. S. Army Engineer Waterways Experiment Station (WES)
 - (3) Universities
- c. Contact personnel involved in the regulatory process, requesting suggested input:
 - (1) EPA Regional Offices
 - (2) U. S. Army Engineers District Offices

This information was compiled and presented in one of three major sections:

- a. A discussion of rationale for project managers.
- b. A step-by-step protocol for sample handling and each test procedure.
- c. A listing of analytical techniques, including sample pre-treatment procedures.

4. The purpose of the first section is to point out to a project director or project manager the types of trade-offs that have to be considered in developing an acceptable sampling program. Unfortunately, it is not possible to give project-specific guidance in a manual such as this. However, if a project director is aware of the kind of information provided by use of each piece of equipment or testing procedure, and the present limitations of this information, he can then make a decision to use the equipment and/or procedures that are most suited to his particular project.

5. The second section of the handbook provides guidance to the laboratory and field personnel that will be implementing the sampling program. This includes a discussion of the types of sampling equipment to be used and when to use each type, a step-by-step description of the three general chemical tests considered, along with the required method of sample handling, and a general quality control program, beginning with sample collection. The three chemical tests that are described are:

- a. A short-term water leaching test (the standard elutriate test).
- b. A strong acid digest or an organic solvent extract (bulk analysis).
- c. An elemental distribution test (sediment fractionation).

6. The third section presents for laboratory personnel a series of analytical techniques, including sample preparation, where required, for 44 parameters. Since the purpose of this manual was not to develop new methods, the methods are generally those found in Standard Methods, ASTM, and EPA manuals. The listed procedures are considered most appropriate for general use; it is recommended that they be utilized when it is decided to analyze samples for that particular constituent. However, the fact that 44 procedures are included is not meant to imply

that all tests should be run on all samples or that additional parameters should not be considered where appropriate.

References

1. Environmental Effects Laboratory. "Ecological Evaluation of Proposed Discharge of Dredged or Fill Material into Navigable Waters." Interim Guidance for Implementation of Section 404(b)(i) of Public Law 92-500 (Federal Water Pollution Control Acts Amendments of 1972). Environmental Effects Laboratory, U.S. Army Engineer Waterways Experiment Station, Vicksburg, Mississippi. Report D-76-17. 83 p. (1976).
2. American Public Health Association. Standard Methods for the Examination of Water and Waste Water Including Bottom Sediments and Sludges. 14th Edition. APHA, New York, New York. 1193 p. (1975).
3. American Society for Testing Materials. "Part 31. Water." American Society for Testing Materials, Philadelphia, Pennsylvania (1976).
4. U. S. Environmental Protection Agency. "Methods for Chemical Analysis of Water and Wastes." Environmental Monitoring and Support Laboratory, U.S. EPA; Cincinnati, Ohio (1979).

SECTION 1: PROJECT MANAGEMENT GUIDANCE

The initiation of a sediment, soil, and water sampling program is a difficult task because of the large number of factors that must be considered. These factors include such technical decisions as:

- a. Selection of sampling locations.
- b. Selection of sampling equipment.
- c. Number of samples to collect.
- d. Type of tests to be performed on the samples.
- e. Specific chemical analyses to be performed.

The purpose of this handbook is to provide state-of-the-art guidance, particularly for personnel involved in regulatory programs such as Section 404(b) of PL 92-500, for sampling and chemical characterization of contaminants associated with dredged and fill materials.

Two levels of guidance are provided to satisfy the purpose of this handbook. One level consists of a decision as to how to handle a sample following collection or how to perform a specific chemical test once a decision has been made to run the test. This information is directed to the field personnel or laboratory personnel that will be processing the samples and is found in Section 2 and Section 3. The second level of guidance is directed towards project managers or other administrative personnel that decide where to collect samples or what tests are to be run. This information is presented in the remainder of this section.

Any guidance provided to project managers, by necessity, must be more subjective than that provided to laboratory and/or field personnel. For example, in designing a generalized sampling program, it would be ideal to specify more samples and replicates rather than fewer, the use of corers rather than grab samplers, and the running of all tests and all chemical analyses. Such an approach would maximize the information obtained from a project area and result in a broader environmental evaluation. However, it is realized that there will be times when real-world constraints such as manpower and/or fiscal limitations will limit this approach. At other times, project goals may be so explicit that it is not necessary to run all tests.

Since factors such as fiscal limitations and project goals are site specific and cannot be addressed in a general manual, the following discussion will summarize the administrative decisions that must be made in establishing a sampling program. Therefore, a project manager will be aware of how the information to be gained by including a specific test benefits his program, and what information is sacrificed by excluding a test from his program.

Project Definition

An essential component of any field sampling program is a preproject meeting with all concerned personnel. The list of concerned personnel in attendance should include representatives from management, field operations, and laboratory operations. The purpose of the meeting should be to define the objective of the sampling program and to ensure communication between participating groups.

The function of conducting a sampling program and performing specific tests on the samples is to gain information. It should be obvious that the amount of information gained will be directly proportional to the number of samples collected and the number of tests performed. However, the information generated through a sampling program must be directed at a specific need. The purposes of defining the objective(s) of a sampling program should be to clarify the information needed and to match these needs with the specific tests that supply the required information.

The definition of a project should be more specific than "an environmental assessment of a proposed dredge or fill material disposal operation." Although an environmental assessment may be the overall objective, this objective would be considered a cumulative effect. Therefore, the objective of the sampling program should be subdivided into specific tasks such as:

- a. Compare two or more sites in a project area.
- b. Quantitate the total amount of certain contaminants present.
- c. Determine the mobility of contaminants in dredged and/

or fill material.

- d. Determine the distribution of certain chemical contaminants in the sediments of a project area.
- e. Determine potential sediment toxicity.
- f. Determine the biological suitability of project site water.
- g. Determine whether a local discharge has altered the water and/or sediments in the project area.
- h. Determine the sediment phase distribution of certain chemical contaminants in the sediments of a project area.

The more explicitly the goals of a project can be stated, the easier it should be to select the tests to be run and the method of sample handling.

Test Selection

Testing procedures

Another aspect of the planning meeting is to determine the specific tests and analyses to be completed. The selection of the type of tests for water samples is generally limited to water quality tests and bioassays. These results can then be evaluated by contrasting the results with established water quality criteria and interpreting the bioassay results.

Types of tests available for the analysis of sediments include:

- a. Bulk analysis.
- b. Standard elutriate test.
- c. Fractionation/extraction procedures.
- d. Physical analysis.
- e. Bioassay.
- f. Bioaccumulation.

The utility of any one sediment test for a particular project can only be determined after the purpose of the study has been identified since each test provides different information as indicated below:

- a. Bulk analysis provides an estimate of the total concentration of a constituent in the sediment sample. The analytical result will include the various sediment phases (interstitial water phase, exchangeable phase, residual phase, etc.) but is poorly related to the biological availability of the constituent. A beneficial

aspect of this test is that storage and presentation problems are minimized since changes in the oxidation state generally do not affect total concentrations. Bulk analysis results are useful for calculating an inventory of the total amount of a constituent involved in a dredging or filling project. However, a major limitation of the test is that the results are a poor indicator of the potential environmental effects of moving the material (as in a dredging operation) because of the poor relationship between biological availability and total concentration.

- b. The standard elutriate test provides an estimate of the mobility of chemical constituents from sediments to the water column. This test has the advantage of being more environmentally interpretable since it measures "water-soluble" constituents, which are the basis of most water quality criteria. The disadvantages associated with the elutriate test are the lack of understanding of the mixing process, which could influence interpretation; the fact that the test is of short duration and may not estimate long-term changes following disposal; and the fact that this test, like bulk analysis, does not address possible impacts on the benthic fauna. In addition, the test requires a greater effort for storage and preservation of samples since oxidation-state changes can alter test results.
- c. Fractionation procedures provide more detailed information on the distribution of chemical constituents within the sediments by subjecting the sample to a series of increasingly harsh extraction solutions. It is possible that there may be a crude inverse relationship between the harshness of the extraction solution and the bioavailability of the constituents. However, the full meaning of a given distribution is not understood. Further limitations of this procedure are that the actual testing is more time-consuming and strict storage requirements are mandatory.
- d. Physical analysis can provide information on particle size, mineralogical characterization, color, and texture. Some of the results can provide an indication of the adequacy of the sampling program. Storage and preservation requirements are generally minimal.
- e. Bioassay procedures are beyond the scope and purpose of this manual. However, their use may be required to evaluate the potential biological response to a particular dredged material disposal or fill material disposal operation.¹ Strict storage and preservation of samples, similar to that used for fractionation procedures or the elutriate test, are required.

- f. Bioaccumulation studies are a subset of bioassay procedures. Their use may be required to determine whether chemical contaminants of interest can be concentrated to undesirable levels by locally important organisms under in situ or controlled laboratory conditions. Sample storage time should be kept to an absolute minimum as sample dehydration and/or tissue deterioration can affect calculated bioconcentration factors.

Chemical analyses

Similarly, the specific chemical analyses to be performed should be discussed so that sufficient sample is collected at each location and proper methods of sample preservation and storage are available. The selection of chemical parameters to be analyzed should be based on major point sources and contaminants of concern in the project area. Because of the site-specific variability of point sources, no mandatory or minimum list of analyses can be recommended.

Once a list of specific chemical analysis to be performed has been finalized, the required sample containers and appropriate preservation techniques are also determined. This follows from the fact that sample handling and preservation techniques are mandatory for each chemical constituent. While this may be the last decision to be made regarding sample handling, it is important to realize that it must be made prior to actual sample collection so that appropriate materials are available at the time of collection. The need for and limitations of available preservation techniques are discussed later.

Sampling Considerations

A critical aspect of any environmental evaluation is the field phase during which the samples to be analyzed are collected. The importance of this component is underscored by the fact that the quality of any such evaluation is only as good as the information gained through sampling. Thus, any errors incurred during sampling will manifest themselves by limiting the accuracy and/or the appropriateness of the study.

The objective of such collections is to obtain samples from

a project area with the purpose of characterizing the area sampled.² Sample size should be small enough to be conveniently handled and transported and yet sufficient to meet the requirements for all planned analyses. The quality of the information obtained through the sampling process is dependent upon:

- a. Collecting representative samples.^{2,3,4}
- b. Using appropriate sampling techniques.³
- c. Protecting the samples until they are analyzed (sample preservation).^{3,4}

Ideally, each of the three factors will be fully understood for each project. In practice, however, this is not always the case. There may be times when fiscal, time, or other resource constraints will limit the amount of information that can be gathered. When this occurs, each of these factors must be carefully considered in light of specific project purposes when designing a sample collection program.

Representative sampling

Several criteria have been established to define the representative nature of a sample. It is considered mandatory that:

- a. The project area being sampled is clearly defined.
- b. The sampling locations are randomly distributed.
- c. More than one sample is collected from each sampling location unless the sample variability has been pre-established.
- d. If sample variability is unknown, it may be necessary to conduct a preliminary survey of the project area to better define the final sampling program.

In defining the project area, it must be remembered that sediment composition can vary in the vertical dimension as well as in the areal dimensions. Thus, samples should be collected over the entire project depth unless the sediments are known to be homogeneous in the vertical dimension. The purpose of collecting random samples is to define the range of chemical concentrations or characteristics that may be found in the project area. The easiest task in establishing a sampling program is to locate the areas of maximum concentrations that are generally located near major point sources and/or areas of quiescent settling. However, results from these sampling locations

are not representative of the range of concentrations in the project area. Therefore, additional sampling must be conducted throughout the remainder of the project area. The last two criteria (c and d) relate to the number of samples that should be collected. In effect, the number of samples required is inversely proportional to the amount of known information and proportional to the level of confidence that is desired in the results.

In addressing the question of representativeness, it is possible to define two populations:^{2,5} one population is the actual composition of sediments in the project area; the second population is the composition of the sediment samples obtained from the project area. Ideally, these populations will be the same. However, it is necessary to be aware of the fact that differences may exist between these two populations because of bias in the sampling program. Factors that can contribute to the bias are oversampling near major point sources and equipment limitation (i.e. extrapolating surface grab sample results to subsurface sediments).

Any established field program should be sufficiently flexible to allow changes based on field observations. The heterogeneity of the water column can be readily assessed through the use of electrometric probes for conductivity, dissolved oxygen, and pH. If the vertical profiles for these parameters are uniform, water column sampling probably can be minimized. However, if stratification is indicated, sampling should be conducted in each of the defined layers. Sediments generally are more heterogeneous than the water column, but the variability is not as easy to compensate for in the field. Certain characteristics of the sediments, such as color or texture, will provide an indication of patchiness. The greater the patchiness, the larger the number of samples that will be required to define the project area. Other valuable sources available to refine a sampling program can be historical data and/or a preliminary sampling survey at the site.

Ultimately, it must be admitted that representativeness is one of the most difficult concepts to reduce to operational practice.

The condition of representativeness is essential to most statistical tests; but, despite its fundamental importance, the only positive practice that can be advocated is to be aware of the possible introduction of bias during sampling.

Sampling site locations. The EPA⁶ has identified seven factors that should be involved in sampling site selection. These factors are:

- a. Objectives of the study.
- b. Accessibility.
- c. Flows.
- d. Mixing.
- e. Source locations.
- f. Available personnel and facilities.
- g. Other physical characteristics.

The actual sampling pattern to be used, by necessity, has to be site dependent because major point sources, land use activities, hydrologic conditions, and sample variability fluctuate from area to area.

The pattern should consider major point sources in the project area and currents that could be critical to the sediment distribution pattern. Thus, primary station locations should be located downstream from major point sources and in quiescent areas, such as turning basins, side channels, and outside channel bends, where fine-grained sediments are most likely to settle. The intensity of sampling around point sources will be influenced by project purposes and available resources. If the purpose is to identify and locate point sources, a higher sampling density will be needed. Additionally, samples should be collected above and below the discharge so the relative input and impact can be ascertained. If the purpose of the project is to characterize sediments and/or fill material that will be affected by a dredging or filling operation, a lower sample density, proportional to sample heterogeneity, should suffice.

Sampling in quiescent areas of harbors, rivers, and channels is advocated because these areas are conducive to the settling of

finer materials. The importance of this size fraction is that the concentration of many constituents is concentrated within the smaller particle sizes. For example, Helmke et al.⁷ and Forstner et al.⁸ have shown higher concentrations of metals in the <2 μ size fraction. Helmke et al.,⁷ in particular, have shown that this size fraction delineates sources and dispersion much better than total sediment analysis.

Sampling patterns based on the above suggestions would be logical. In addition, a knowledge of the point sources would provide a basis for selecting the parameters for which analyses should be completed. A limitation with this approach is that the sample results will be biased high. That is, the primary sampling locations are situated near point sources where concentrations would be expected to be higher (or highest) and in quiescent areas with a higher percentage of fine material (and a concurrently higher concentration of associated contaminants). It may be desirable under certain circumstances (i.e. regulatory agencies may want to know maximum concentrations) to collect such samples; but, as a consequence, the samples cannot be considered representative of the concentration distribution in the project area; the validity of extrapolating conclusions from these samples to the entire project area is questionable. Therefore, in order to provide some degree of representativeness, the primary sampling locations listed above should be supplemented with random stations located throughout the project area. At the present time, no firm guidance can be given on the number of additional sampling stations that should be established. However, it is suggested that the number of such additional sampling stations be equal to or slightly greater than the number of sampling stations located in the vicinity of major point sources to compensate for the high bias.

An additional factor that should be included in establishing a sampling program is the selection of a reference station and/or a control station. Data from a reference or control station are required for a site comparison, as outlined in the Federal Register.⁹ Sediments

in such areas are subject to the same heterogeneity as discussed earlier. To compensate for this variability, it is recommended that reference area sampling be replicated.

The following general guidance is offered as an aid in establishing a sampling program:

- a. Sampling stations should be located downstream from major point sources in the project area. These sources may be selected based on specific constituents in the effluent or the volume of the discharge. It is usually possible to define these sources based on a knowledge of the activity in the area or a review of historical data for the site.
- b. Additional sampling stations should be located in areas of low hydrologic activity or energy. The reason for sampling these locals is that the lower energy favors the settling of smaller sized suspended particulate matter.¹⁰ This material, due to the greater surface area per unit weight of particulate matter, tends to have higher concentrations of associated chemical contaminants.^{7,8} Suggested locations are: (1) on the outside bend of channels, (2) in backwater areas or side channels, and (3) in areas of heavy shoaling or deposition.
- c. Sampling stations should be located in other areas not covered in categories a and b above. Sampling is necessary below major point sources and in areas of settling to define the maximum concentration that will be found in the sediments of the project area. However, this specific property, maximum concentration, would make such samples nonrepresentative. Therefore, samples also should be collected at random locations removed or upstream from major point sources and in areas of higher hydraulic energy (i.e. inside bend of channels). In this way, data obtained from sample analysis will provide information on the range of sediment properties and compositions that can be expected and the entire set of resultant data will be more representative of the project area. The number of sample stations located in such areas should be equivalent to the number of stations in categories (1) and (2) in b above.
- d. If a control area or a former disposal site is to be sampled for comparative purposes, multiple stations should be sampled. Sediment composition from these areas will also be variable and cannot be defined based on single samples.

Number of samples. One of the more difficult tasks is determining the number of samples that should be collected. During

the preparation of this manual, persons experienced with the topics of sediment collection and analysis were interviewed. These individuals could not agree on any specified number of samples. Responses that were obtained ranged from "5 replicates at each location" to "more than 50 in a harbor" to "20 samples per hectare." Again, no specific guidance can be provided; but several general concepts can be presented. First, the greater the number of samples collected, the better the source will be defined. Secondly, the mean of a series of replicated measurements is generally less variable than a series of individual measurements. Thirdly, statistics generally require two characteristics, usually mean and standard deviation, because single measurements are inadequate to describe a sample. Fourthly, the necessary number of samples is proportional to the source heterogeneity.

A consideration of the above factors suggests that replicate samples should be collected at each location and that a minimum of three replicates is required to calculate standard deviations. Beyond the replication at a single point, the factors listed above do not limit the number of samples needed since it depends on site-specific heterogeneity and the desired level of defining the source. Thus, some other factor will have to limit the number of samples collected.

One such factor is financial resources. In this case, the number of samples that can be collected and analyzed is determined by the ratio of available dollars and cost per sample:

$$\text{Numbers of samples} = \frac{\text{Dollars for analysis}}{\text{Cost per sample}} \quad (1)$$

In turn, the cost per sample will depend on the cost of analysis for each parameter, the specific parameters being analyzed, and the number of samples to be processed (quantity discounts). As an aid in estimating analytical costs, Table 1-1 presents information on cost per analysis, and Table 1-2 presents information on the number of samples that can be processed daily. The average costs in Table 1-1 are based on a 1977 survey of government and commercial laboratories.

This approach will provide one method of estimating the number of samples that can be collected and analyzed. However, should the calculated number of samples not be sufficient to establish an

Table 1-1
Analytical Costs by Parameter*

Parameter	Average Cost**	Range of Cost**
Alkyl Benzene Sulfonates	\$15.00	-
Acidity (total)	4.48	\$ 2.50 - 9.00
Aluminum	10.96	4.00 - 20.00
Ammonia	11.81	3.00 - 30.25
Antimony	12.89	5.00 - 35.00
Arsenic	16.29	6.00 - 35.00
Bacteria	13.97	2.50 - 45.00
Barium	10.42	4.00 - 20.00
Beryllium	11.25	4.00 - 20.00
Bicarbonate	7.50	3.00 - 15.00
Bioassay	Generally Quoted Upon Request	-
Biological Oxygen Demand	27.19	10.00 - 115.00
Boron	17.31	7.00 - 35.00
Bromide	12.17	5.00 - 20.00
Cadmium	9.35	2.50 - 16.50
Calcium	7.56	2.00 - 20.00
Carbon	15.71	5.00 - 35.00
Carbonates	7.50	3.00 - 15.00
Carbon Chloroform Extract	62.50	35.00 - 90.00
Carbon Dioxide	9.50	5.00 - 22.00
Chemical Oxygen Demand	14.38	7.50 - 33.00
Chloride	5.79	3.00 - 20.00
Chlorinated Hydrocarbons	42.50	20.00 - 70.00
Chlorine	21.05	1.50 - 100.00
Chlorophyll	11.00	3.00 - 25.00
Chromate	8.75	3.00 - 16.50
Chromium	9.05	4.00 - 20.00

(Continued)

*Personal communication, 1977, J. Westhoff, research chemist, WES.

**1977 prices.

(Sheet 1 of 3)

Table 1-1 (Continued)

<u>Parameter</u>	<u>Average Cost</u>	<u>Range of Cost</u>
Cobalt	\$ 9.30	\$ 4.00 - 9.30
Color	7.30	1.50 - 25.00
Copper	7.88	2.50 - 20.00
Cyanide	19.93	5.00 - 40.00
Detergents	12.50	7.50 - 20.00
Dissolved Oxygen	4.60	2.50 - 8.00
Fluorides	12.00	3.50 - 25.00
Hardness	4.85	1.50 - 10.00
Hydrogen Sulfide	10.00	5.00 - 15.00
Hydroxides	7.00	3.00 - 15.00
Iodine	12.00	10.00 - 15.00
Iron	8.24	2.50 - 20.00
Lead	10.47	2.50 - 20.00
Magnesium	8.56	4.00 - 20.00
Manganese	9.20	2.50 - 20.00
Mercury	17.50	11.00 - 35.00
Methane	15.00	11.00 - 35.00
Molybdenum	10.88	4.00 - 20.00
Nickel	9.40	2.50 - 20.00
Nitrate	8.17	3.00 - 16.50
Nitrite	7.50	5.00 - 12.00
Total Kjeldahl	18.05	6.00 - 30.25
Odor	13.67	1.00 - 30.00
Oil and Grease	27.75	7.00 - 150.00
PCB's†	33.33	25.00 - 40.00
Pesticides	49.00	20.00 - 75.00
pH	3.05	1.50 - 5.00
Phenols	21.11	5.00 - 36.50
Total Phosphorus	9.00	6.00 - 12.50
Orthophosphorus	5.57	2.00 - 10.00
Potassium	8.77	2.00 - 20.00

(Continued)

† Polychlorinated biphenyls.

(Sheet 2 of 3)

Table 1-1 (Concluded)

<u>Parameter</u>	<u>Average Cost</u>	<u>Range of Cost</u>
Selenium	\$20.72	\$ 5.00 - 55.00
Silica	10.03	4.00 - 20.00
Silver	10.70	4.00 - 20.00
Sludge Volume Index	12.00	10.00 - 14.00
Sodium	8.95	2.00 - 20.00
Total Solids	7.00	4.50 - 11.00
Volatile Solids	6.63	1.50 - 16.50
Dissolved Solids	7.23	4.50 - 14.00
Suspended Solids	7.00	2.00 - 13.50
Settleable Solids	5.85	2.00 - 12.00
Specific Conductance	3.95	1.50 - 5.00
Specific Gravity	8.13	1.50 - 20.00
Strontium	20.79	4.00 - 75.00
Sulfate	8.75	4.00 - 18.00
Sulfide	11.23	5.00 - 25.00
Sulfite	7.89	3.00 - 12.50
Surfactants	18.04	10.00 - 28.00
Tannin and Lignin	14.86	7.50 - 25.00
Taste	50.00	20.00 - 100.00
Thallium	12.20	4.00 - 20.00
Thiocyanate	12.50	10.00 - 15.00
Tin	11.15	2.50 - 20.00
Turbidity	3.89	1.50 - 6.00
Vanadium	11.11	4.00 - 30.00
Volatile Acids	20.00	-
Zirconium	21.67	10.00 - 35.00
Zinc	9.63	2.50 - 20.00

(Sheet 3 of 3)

Table 1-2
Performance Requirements,*
Number of Samples Per Day Per Man

<u>Parameter</u>	<u>Number of Water Samples per Day</u>
Dissolved Oxygen (probe)	150
Dissolved Oxygen (Winkler)	120
pH	175
Conductivity	120
Turbidity (Jackson)	75
True color (filtration)	60
Oxygen uptake	-
Biological Oxygen Demand (probe)	40
Biological Oxygen Demand (Winkler)	30
Immediate Oxygen Demand	-
Chemical Oxygen Demand	24
Chlorine Demand	-
Alkalinity (total)	100
Acidity (total)	100
Total Kjeldahl Nitrogen (manual)	20
Total Kjeldahl Nitrogen (automated)	100
Phosphorus - Total (manual)	50
Phosphorus - Total (automated)	100
Phosphorus - Total Soluble	100 - 150
Solids - suspended and dissolved	20
Solids - total and volatile	-
Phenol (distillation)	20
Oil and Grease (Soxhlet)	12
NH ₃ -N (automated)	100
NO ₃ -N (automated)	100
NO ₂ -N (automated)	100
Chloride (automated)	100

(Continued)

* Personal communication, 1977, J. Westhoff, research chemist, WES.

Table 1-2 (Concluded)

<u>Parameter</u>	<u>Number of Water Samples per Day</u>
Sulfate (automated)	100
Magnesium (direct aspiration)	100 - 150
Silica (automated)	100
Sodium (direct aspiration)	150
Potassium (direct aspiration)	150
Calcium (filtration/direct aspiration)	100
Arsenic	20
Fluoride (distillation)	25
Fluoride (automated)	100 - 125
Cyanide (distillation)	12
Sulfide (titrimetric)	50 - 75
Manganese (direct aspiration)	150
Total Iron (digestion/direct aspiration)	60 - 80
Copper (direct aspiration)	150
Cadmium (direct aspiration)	150
Nickel (sample concentration/direct aspiration)	150
Zinc (direct aspiration)	150
Lead (direct aspiration)	150
Chromium (direct aspiration)	150
Pesticides	
Chlorinated	10 per 12 days
Sulfated	10 per 12 days
Carbon Filter	10 per 18 days

adequate sampling program (i.e. number of samples not sufficient to allow triplicate sampling at all locations indicated in the section on Sampling Site Locations), one of the following trade-offs will have to be accepted:*

- a. Reduce the replicate sampling at each station. This will allow the chemical distribution within the project area to be determined; but variability at a single sampling location cannot be calculated.
- b. Maintain replicate sampling but reduce the number of sampling locations. This will result in the project area being less well defined but sampling variability can be calculated.
- c. Reduce the number of analyses that will be run on each sample. In this way, samples only have to be analyzed for specific parameters of concern in a given project area. Because the analyses to be run are site specific, no mandatory list of analyses can be recommended at this time.
- d. Increase the financial resources available for sample analysis. This will increase the number of samples that can be collected and analyzed.

A second factor that can be used to estimate the number of samples needed for a project is the level of statistical reliability or confidence that is desired in the results. In the case where a random sample has been taken and in reference to any particular chemical parameter of interest, this can be calculated as:¹¹

$$n_o = \frac{t^2 s^2}{d^2} \quad (2)$$

where

- n_o = number of samples
 t^2 = student's-t distribution value
 s^2 = population variance
 d^2 = statement of margin or error

* The distinction between option a and option b should be based on project-specific goals. If option a is used (more stations, fewer replicates), the results will provide a better indication of distribution patterns in the project area (Synoptic Survey); but it will be difficult to compare individual stations. On the other hand, if option b is used (fewer stations, more replicates), the results will provide a better indication of variability at one location and a comparison between sampling stations. However, the project area will be less well defined.

It should be noted that this method will most likely lead to different numbers of samples being required for each parameter and trade-offs will have to be made in selecting the final number of samples to collect.

Because of the inherent heterogeneous nature of sediments, one should be prepared to accept rather large values for n_0 or d when using this approach. As an example, in one study in Lake Erie,¹² 100 samples were collected from a 100-square-mile area.* Based on $n_0 = 100$, $t^2 = 4$ (95 percent confidence level), and $s^2 = 46.10$ (observed variance = 6.79), the calculated d value is 1.4 mg/kg. In other words, based on the analyses of 100 samples, one could be 95 percent confident that the mean cadmium concentration was within 1.4 mg/kg of the true mean. If one wanted to be 95 percent confident that the mean cadmium concentration was within 1.0 mg/kg of the true mean, a total of 184 samples would have to be collected.

This approach obviously requires a knowledge of historical data and/or an examination of the project site. It can be used to calculate the required number of samples in a project area after stating the confidence desired in the final data d and knowing the variability in the project area s^2 . However, the approach can also be used after completion of a sampling program, when n_0 and s^2 are known, to calculate the level of confidence that can be placed in the final data.

It is suggested that some consideration be given to collecting samples (locations and numbers) in excess of that determined by either of the above processes. The samples do not have to be scheduled for analysis and may even be discarded later without analysis. However, sediments can be highly heterogeneous as discussed earlier; and should sample analysis indicate some sort of anomalous results, it is easier to analyze additional samples already on hand rather than to remobilize a field crew. Also, the additional variable of different sampling times is avoided with this approach.

Frequency of sampling. Frequency of sampling will depend on the available resources and the size of the project. Most persons

* A table of factors for converting U. S. customary units of measurement to metric (SI) is presented on page xv.

interviewed during the preparation of this manual suggested that seasonal fluctuations of sediment concentrations may not be critical and a single sampling prior to a dredging or filling operation may be sufficient for a new work project. A sampling frequency of once per year would probably also be sufficient for an annual maintenance project, unless there is a "reason to believe" otherwise (i.e., some major change in point sources or basin hydrology).

An assessment of sampling frequency will be subjective. The factors that are likely to influence the adequacy of the sampling frequency are duration of the project, time of the year, and local activities. The shorter the project duration, the less likely that multiple samplings would be required. However, as the project duration increases, particularly to time frames of three months or longer, consideration should be given to increased sampling frequency. The second two points are an extension of the first factor. There may be no potential problems when a project is initiated; but a lengthy project may extend into a critical spawning or migration season. This could force an increased sampling frequency or, at a minimum, a reevaluation of the earlier data based on changes in seasonal activities. Obviously, considerations of this type are site and project specific. It is recommended that an increased sampling frequency be used when a project is expected to last longer than one quarter (three months), unless it is known that the project will not impact or be impacted by a locally important seasonal activity.

Sampling techniques selection

Sampling equipment is frequently selected based on reliability, efficiency, and contamination potential. Information on these characteristics is summarized in Section 2. Project managers should also be aware of the fact that the selection of sampling equipment may affect the apparent sample variability. As discussed earlier, sample variability can influence the number of samples required for analysis or the confidence that can be placed in the resultant data.

Sediments are frequently stratified in the vertical dimension as well as in the horizontal dimension. This source of variability

should be considered when establishing a sampling program, particularly when choosing a method of sampling (i.e., grab or dredge vs. corer). A grab sampler (i.e. Ponar, Ekman, and Orange Peel) is a device that usually triggers after free-falling and is used to retrieve surficial sediments. The difficulty with this approach is that the depth of sediments penetrated by the sampler may vary, depending on the weight and shape of the sampler, the sediment texture and density, the height of free-fall, and the angle of impact.^{13,14} Since many chemical constituents display surface enrichment trends, the use of grab samplers may introduce analytical variability into the final data that is a function of dredge penetration rather than being a property of the sample.

For example, in a hypothetical situation in which the concentration of a constituent varies from 1 to 10 mg/kg, an average concentration as a function of dredge penetration was calculated (Figure 1-1). A 1-cm surface grab in this example would have an average concentration of 10, while a 3-cm grab would have an average concentration of 5.6; and a sample that penetrates more than 8 cm would have an average concentration of less than 3. Thus, in an extreme case, a differential dredge penetration could produce more than a 300 percent variation in the analytical results at the same sampling location. A difference in penetration of 1 cm could produce analytical variability of 7 to 43 percent. The actual variation will depend on the site-specific depth profile and the differential depth of penetration.

A study by Skoch and Britt¹⁵ demonstrated the effect of corer vs. dredge sampling. Dredge samples collected over a 2-year period had an average phosphate concentration of 2.24 ± 0.44 mg/kg. The uppermost section of a core (0 to 2.5 cm) sample had an average phosphate concentration of 2.73 ± 0.29 mg/kg; and a lower section of the core (12.5 to 15 cm) had an average phosphate concentration of 2.17 ± 0.24 mg/kg. Thus, the analytical results obtained with an Ekman dredge were not directly comparable to the corer results; and, in addition, the dredge results were more variable as suggested by the larger standard deviation. It was concluded that core samplers may be more valuable than dredges for sediment studies.

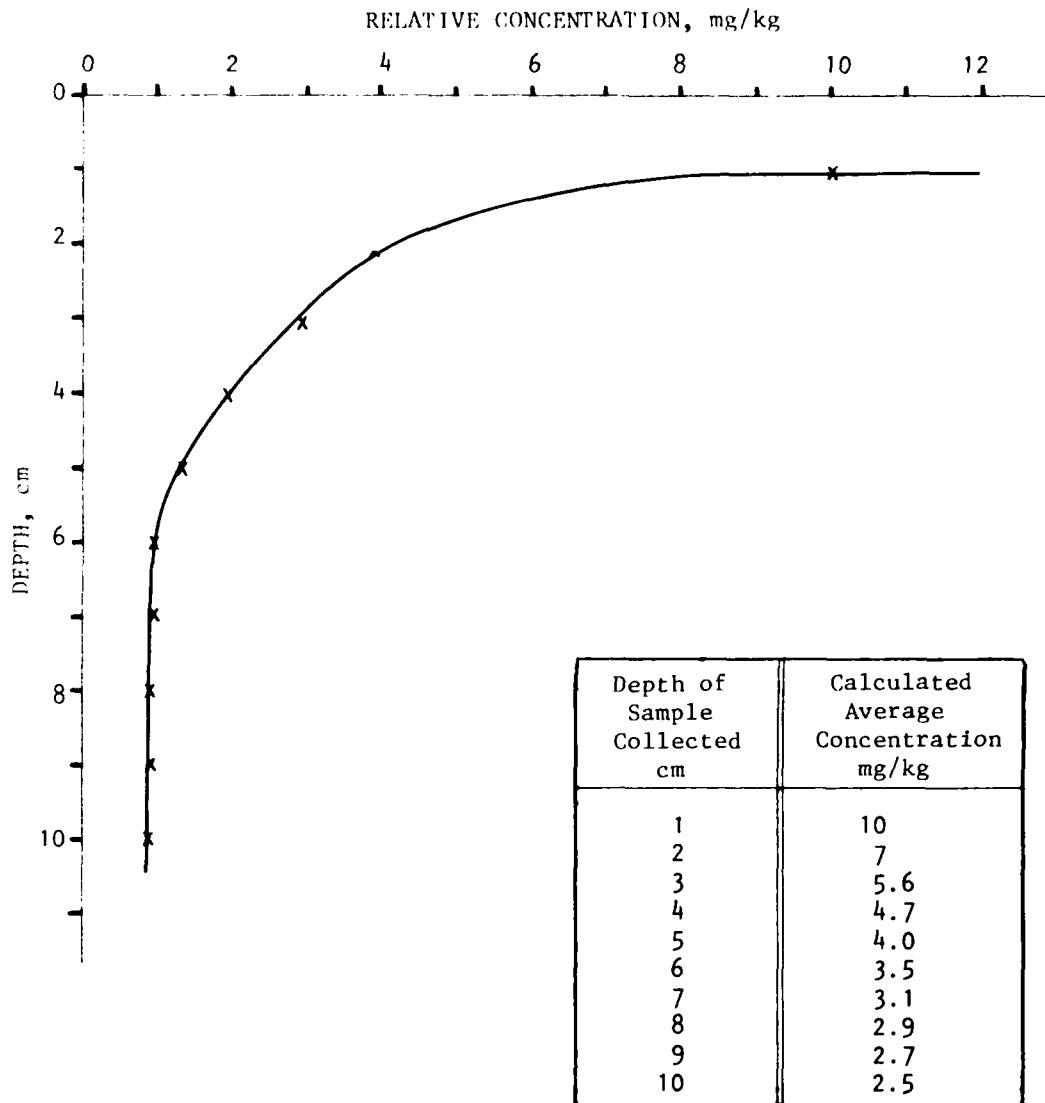

Figure 1-1. Average concentration as a function of dredge penetration

The previous discussion assumes that the vertical stratification in sediments is uniform. However, irregular folding of sediment layers frequently occurs. This situation can make it more difficult to compare grab samples taken from the same area and compound the potential analytical bias identified earlier.

The choice between grab samplers and corers can be based on convenience or availability when the deposit to be sampled is homogeneous with depth since both methods should give the same result. However, the selection of a grab sampler in a stratified deposit is liable to yield biased conclusions and is certain to lose potentially valuable information. It also is cautioned that such use may require the collection and analysis of more samples to compensate for the analytical bias that may be introduced. Thus, it is suggested that corers would be the preferential method of sample collection and should be used where available.

One situation where the selection between grabs and corers may not be critical is in the evaluation of dredging activities in maintenance work projects. In these areas, the sediments that have accumulated since the last maintenance project are generally subjected to continual reworking due to marine traffic. The net effect of this activity homogenizes the sediments that have accumulated. Because maintenance dredging is concerned with the removal of accumulated sediments rather than deepening or creating new channels and the previous discussion indicated no difference between corers and dredges in homogeneous deposits, grab samplers should be sufficient in these situations.

When the project being evaluated includes either deepening of an older channel or creation of a new channel, it is recommended that cores be collected. Also, when possible, the cores should be taken to a depth equivalent to the proposed project depth.

Sample preservation

Methods. The importance of sample preservation between time of collection and time of analysis cannot be overemphasized. The purpose of collecting samples is to gain understanding of the source of

the samples; any changes in sample composition can invalidate conclusions regarding the source of the samples.⁴ To phrase it another way, results based on deteriorated samples negate all efforts and costs expended to obtain good samples.

The most efficient way to ensure a lack of sample deterioration is to analyze samples immediately. However, this is usually not practical because of:

- a. The number of samples collected.
- b. The type of equipment needed for analysis.
- c. The steps involved in sample preparation.

Therefore, some method must be relied upon to extend the integrity of the sample until the analyses can be completed. In taking this approach, it must be remembered that complete stabilization is not possible and no single preservation technique is applicable to all parameters.¹⁶

Preservation methods are relatively limited and are generally intended to retard biological action, hydrolysis, and/or oxidation of chemical constituents and reduce volatility of constituents.¹⁵ The methods are limited to pH control, chemical addition, sample isolation, and temperature control (refrigeration and/or freezing). Selection of a preservative should be based on the purpose of the study and the constituent to be measured. If one is interested in the total concentration of iron in sediments, either drying, freezing, or refrigeration in an airtight container would be satisfactory. However, if one is concerned about the mobilization of iron from sediments to the water column, only the latter preservation technique, refrigeration in an airtight container, would be acceptable. Because of the limited number of preservation techniques, it is obvious that they are not parameter specific. The use of one preservative may invalidate the use of that sample for the analysis of a second parameter (i.e., samples preserved with mercury salts to retard biological activity cannot be analyzed for mercury; samples preserved by drying should not be analyzed for oxygen demand). As a consequence, multiple samples will have to be collected and individually preserved or a single sample will have to be split into subsamples and preserved as

required. The elapsed time between sample collection and sample preservation must be kept to an absolute minimum.

Appropriate containers and methods of preservation for water samples have been generally agreed upon and are presented in Sections 2 and 3 of this handbook. Transportation and preservation of sediment samples have not been fully evaluated. However, it is suggested that glass containers be used when the sample is to be analyzed for organic constituents and glass or plastic containers be used when the sample is to be analyzed for inorganic constituents as suggested for water samples.¹⁶ Sediment samples should be sealed in airtight containers to preserve the anaerobic integrity of the sample and maintain the solid phase-liquid phase equilibrium.

Sample handling. Proper sample handling is essential to obtain successful results from any monitoring program. It is the responsibility of the project manager to ensure that samples be correctly handled between collection and analysis. This includes:¹⁶

- a. Using noncontaminating sampling devices.
- b. Having appropriately cleaned sample containers available (glass for organic analysis, acid-rinsed bottles for metals, etc.).
- c. Having appropriate chemical preservation and/or preservation techniques readily available.
- d. Using a reliable sample labeling-and-identification procedure.

It is also necessary that the samples be logged in after collection and analyzed within prescribed time limits. Each of these factors is specified or discussed in more detail in Section 2 but are mentioned here because of their importance.

Quality Control

The factors associated with sample handling are important because they influence the quality of the data being generated. It should be apparent, based on the factors mentioned above, that an effective quality control program must be an integral part of a project from the initiation of field sampling and should be considered

during project planning. During the initial meeting, the field crew should be made aware of the fact that chemical changes can occur following collection of samples; they should also know how to handle the samples to minimize or prevent these changes. In addition, it may be helpful if the field crew knows the type of analyses to be performed so they can minimize sample contamination problems. At the same time, laboratory personnel should be reminded of their responsibility to complete the required analyses within the specified time period.

A complete quality control program should emphasize two areas. The first area is sample handling techniques. This is necessary because the greatest potential for sample deterioration and/or contamination occurs during the preanalysis steps of sample collection, handling, preservation, and storage. These problems can be minimized by following prescribed sample handling techniques. The second area to be emphasized is that of analytical quality control. This is accomplished by analyzing field replicates, split samples, and spiked samples.¹⁶ For water samples, the quality control program should include the analysis of field replicates, samples spiked in the field, laboratory duplicates, and samples spiked in the laboratory. For sediment samples, the quality control program should include the analyses of field replicates, laboratory duplicates, and samples spiked in the laboratory. Field-spiked sediment samples would be awkward since the spike would probably not equilibrate and mixing would destroy sample integrity. A recommended quality control program should consist of 15 to 20 percent of the total sample load. It is further recommended that the laboratory participate in quality control round-robin sample analysis studies.

Additional Considerations

The purpose of conducting a sampling effort is to gain information. The quality of the information gained can only be as good as the care in preparing for and implementing the effort. Since

definitive guidance on the number of sampling locations and number of samples cannot be given, one step to ensure a high quality field program is to use experienced field personnel. In addition to experience, another useful characteristic is a high level of communication. Field personnel should be familiar with the purpose of the study and the analyses that will be completed on the samples. This will permit them to use their judgment in the most constructive manner and alert them to specific precautions that should be taken in sample collection, preservation, and storage.

Summary

This section has endeavored to present the major factors to be considered in implementing a field sampling program. Factors such as sample handling and quality control should be part of standard laboratory practice and are mentioned for completeness. Other factors such as method of sampling (core vs. dredge) and type of test (standard elutriate test vs. elemental partitioning vs. bulk analysis) are mentioned because of the choice afforded. Each alternative provides certain information and sacrifices other information. Specific guidance can be provided for each procedure; but it is up to the project manager to decide which procedure is most useful for his project. Finally, there are factors such as sampling locations and number of samples for which specific guidance cannot be given because of site-specific influences. Again, the project manager will have to address these factors; the potential trade-offs that are involved have been presented herein for consideration (greater replication vs. fewer sampling locations; more samples and fewer analyses per sample vs. greater sample characterization of fewer samples).

References

1. Environmental Protection Agency/Corps of Engineers Technical Committee on Criteria for Dredged and Fill Material. "Ecological Evaluation of Proposed Discharge of Dredged Material into Ocean Waters; Implementation Manual for Section 103 of Public Law 92-532 (Marine Protection, Research, and Sanctuaries Act of 1972)." Environmental Effects Laboratory, U.S. Army Engineer Waterways Experiment Station, Vicksburg, Mississippi. 24 p. + APP. July 1977 (2nd Printing 1978).
2. Griffiths, J. C. Scientific Method in Analysis of Sediments. McGraw-Hill Book Company, New York. 508 p. (1967).
3. American Public Health Association. Standard Methods for the Examination of Water and Waste Water Including Bottom Sediments and Sludges. APHA, New York. 769 p. (1965).
4. Research and Education Association. Modern Pollution Control Technology. Vol. 2. Water Pollution Control and Solid Waste Disposal. Research and Education Association, New York. Unnumbered (1978).
5. Griffiths, J. C. "Statistical Methods in Sedimentary Petrography." In: Milner, H. B. (Ed.), Sedimentary Petrography. George Allen and Unwin, Ltd., London. pp. 565-617 (1962).
6. Sherma, J. "Manual of Analytical Quality Control for Pesticides and Related Compounds in Human and Environmental Samples." Contract 68-02-1727. U. S. EPA Health Effects Research Laboratory, Research Triangle Park, North Carolina. EPA-600/1-76-017. Unnumbered (1976).
7. Helmke, F. A., Koons, R. D., Schomberg, P. J., and Iskandar, I. K. "Determination of Trace Element Contamination of Sediments by Multielement Analysis of Clay-Size Fraction." Environmental Science and Technology 11: 984-989 (1977).
8. Forstner, U., Patchineelam, S. R., and Feurer, R. "Grain Size Distribution and Chemical Associations of Heavy Metals in Fresh-water Sediments (Examples from Bodensee and Rhine)." Presented before ACS Environmental Chemistry Division, 175th National Meeting, Anaheim, California. Unnumbered (1978).
9. Federal Register. Vol. 40, No. 173. Friday, 5 September 1975.
10. Sydor, M. "Particulate Transport in Duluth-Superior Harbor." Physics Department, University of Minnesota, Duluth, Minnesota. Grant R-803522. Draft Report. 101 p. (1978).
11. Weber, C. E. (Ed.). "Biological Field and Laboratory Methods for Measuring the Quality of Surface Water and Effluents." National Environmental Research Center, U. S. EPA, Cincinnati, Ohio. EPA-670/4-73-001. Unnumbered (1973).

12. Great Lakes Laboratory. "Airport Feasibility Study for the Lake Erie Regional Transportation Authority." Contract Report prepared for Howard, Needles, Tammen, and Bergendoff. Report 6-5. Great Lakes Laboratory, State University College at Buffalo, Buffalo, New York. 278 p. (1974).
13. Hudson, P. L. "Quantitative Sampling with Three Benthos Dredges." Trans. Amer. Fish Soc. 99: 603-607 (1970).
14. Christie, N. D. "Relationship Between Sediment Texture, Species Richness, and Volume of Sediment Sampled by a Grab." Marine Biology 30: 89-96 (1975).
15. Skoch, E. J. and Britt, N. W. "Monthly Variation in Phosphate and Related Chemicals Found in the Sediment in the Island Area of Lake Erie, 1967-1968 with Reference to Samples Collected in 1964, 1965, 1966." Proc. 12th Conf. Great Lakes Res. pp. 325-340 (1969).
16. U. S. Environmental Protection Agency. "Methods for Chemical Analysis of Water and Wastes." National Environmental Research Center, U. S. EPA, Cincinnati, Ohio. EPA-625/6-74-003. 298 p. (1974).

SECTION 2: FIELD/LABORATORY GUIDANCE

This section is intended primarily for the field and laboratory personnel that will be implementing the sampling program. The nature of the guidance in this section is less subjective than the previous section because it deals with how to perform a test rather than when or on what samples to perform a test. The subjects covered include sample collection, sample container preparation, sample handling and storage, quality control, and sample testing procedures. Each of these subjects require some selection of options (grab sample vs. core sample; freezing, drying, or moist storage of samples; use of bulk analysis, elutriate testing, and/or elemental partitioning). However, the choice of the various options should be addressed in the project planning meeting as discussed in Section 1. The purpose of this section is to provide guidance on how to handle the samples or perform a specific test after it has been decided to use a specific procedure.

This section follows the logical progression of sample collection, sample handling and storage, and testing. This represents the physical sequence of handling samples. However, it should be obvious that preparations for sample storage and analysis must be made prior to sample collection in order to minimize the undesirable effects of sample contamination and alteration between sample collection and sample analysis.

Method of Sample Collection

The type of samples to be collected will depend on the specific testing procedures to be used which, in turn, should be based on the purpose of the project since each procedure provides discrete information on the sample. Water samples will furnish information on existing water quality at a proposed project site. Water and sediment samples are required to perform an elutriate test in order to estimate chemical mobility during dredging and disposal activities. Sediment samples are required to determine the chemical

form distribution (elemental partitioning or fractionation) or the total concentration (bulk analysis) of a particular constituent at the collection site.

Water samplers

Devices available for the collection of water samples can be classified in two categories: *discrete samplers and pumps*. While either device can be used satisfactorily, it should be remembered that sampling equipment should be constructed of noncontaminating material.¹⁻⁴

For collecting water samples, free flushing, messenger-triggered stainless steel bottles with no gaskets, and teflon-coated bottles with teflon seals are the better choices from among those available.¹ Polyvinyl chloride (PVC) water bottles can also be used provided the O-ring gaskets, if rubber, are replaced with teflon or some other noncontaminating material.

Water samplers are subject to contamination as the open bottle passes through the water's surface where organics, other floatables, and metals have been shown to accumulate.¹ This potential problem can be minimized by avoiding areas with visible surface slicks or films. In addition, the contaminating effects are further reduced by the natural flushing action of the sampler and the selection of a sampler with a large volume-to-surface area ratio. If surface films are a recurrent problem, an alternative collection method is to use a sampler that is closed during descent and only opened at the desired depth.

When pumps are selected for water sample collection, care should be taken to run the apparatus for a sufficient length of time to ensure that the system has been thoroughly flushed in order that the collections are representative of the sampling location. Allowing a water volume equal to three times the combined tube volume to pass through the system before collections are retained should be sufficient for this purpose. A point of concern should be the contamination potential of packing and lubricants used with the pump. These effects can be avoided by using peristaltic pumps, magnetically coupled impeller designs, or vacuum pump collectors. However, peristaltic

pumps and magnetic pumps should be considered superior to the use of vacuum pumps as the latter will degas the sample. This could, in turn, cause other secondary chemical changes in the sample being collected.

Sediment samplers

There are three broad classifications of sediment collecting devices. These are corers, grabs, and dredges. Corers generally produce the least disturbed samples; grabs collect larger surface samples; and dredges collect larger, well-mixed samples that are considered qualitative.¹ Because there are concerns about the representativeness of dredge samples, dredges should only be used where other sediment samplers are not applicable.

The choice between corers and grabs should be based on the type of project being evaluated. If the project requires new work or harbor deepening, sediment samples should be collected with a corer. In this way, samples can be collected of all the material to be involved in the proposed project. If the project is classified as maintenance work, grabs will usually be sufficient. Practical experience has shown that hydrologic conditions at such locations usually result in homogeneous sediments due to currents and/or marine traffic.* Since vertical stratification would not be expected and older sediments would not be disturbed, coring devices generally are not required for sample collection under these conditions.

Corers function by driving a tube into the sediments, usually through the use of gravity, hydrostatic pressure, or vibration.^{1,5} The length of core that can be collected generally is limited to 10 core diameters in sand substrate and 20 core diameters in clay substrate. Longer cores can be obtained but substantial sample disturbance results from internal friction between the sample and the core liner.

Free-fall cores can cause compaction of the vertical structure of sediment samples. Therefore, if the vertical stratification in a core sample is of importance or interest, a piston

* Personal communication, 1978, from R. Bowden, Chief, Great Lakes Surveillance Branch, Great Lakes National Program Office, EPA Region V, Chicago, Illinois.

corer should be used. These devices utilize both gravity and hydrostatic pressure. As the cutting edge penetrates the sediments, an internal piston remains at the level of the sediment-water interface, preventing sediment compression and overcoming internal friction. If samples will not be sectioned prior to analysis, compaction is an academic problem; and free-fall corers are a suitable alternative.

Grabs are designed primarily to retrieve surficial sediments. A problem identified with the use of grab samplers is that shock waves are generated ahead of the descending samplers and these waves can wash away light, unconsolidated sediments and unattached benthic organisms.^{1,5-8} This effect is minimized by using samplers with flaps, screens, or valves to create a flow-through system during descent. An added benefit is that sample washout protection is provided by the flaps during recovery.^{1,5}

Another problem with grabs is that sampling characteristics (sediment penetration) can be influenced by bottom hardness, depth to sample, and fall rates and angles as well as lateral vessel motion.⁹ These factors can contribute to apparent sample composition variability where sediment concentrations vary vertically. Therefore, it is recommended that the use of grab samplers be restricted to areas of vertically homogeneous sediments.

The various sediment samplers were evaluated for sampling efficiency, reproducibility, and sample protection.⁵ The observations and evaluations are presented in Tables 2-1 and 2-2. Based on these studies, the Shipek and Ponar dredges would be considered the best sampling devices for maintenance projects.

Sample Collection

Sample site locations and number of samples to collect are project specific. The factors that influence the decision on where to sample and how many samples to collect are project purpose(s), major point sources in the project area, activities in the project area, hydrologic conditions, and sample variability. The project

Table 2-1

Operational Evaluation of Grab Samplers*

<u>Grab</u>	<u>Trigger System Reliability</u>
Franklin Anderson	Good, but perhaps too sensitive on hard sand and gravel bottom.
Dietz-LaFond	Poor, unless area of trigger foot is increased to at least 50 cm ² . Triggering may often be impossible in very soft mud unless the foot has been modified.
Birge-Ekman	Good. Triggered by messenger weight dropped from surface, normally consistent but can be affected on soft bottoms if sampler is allowed to settle for too long before dropping the messenger.
Petersen	Fair to good, though tends to be a little oversensitive on hard sand and gravel bottoms.
Fonar	Good, though like the Petersen, tends to be a little oversensitive on gravel bottoms.
Shipek	Good, though some slight settlement may occur before triggering on very soft materials. Sampler may fail to trigger when lowered gently on soft bottoms. By lifting and dropping the trigger weight a few centimeters after bottom contact, abortive casts may be avoided. The slight movement of the inertial trigger weight has no other effect on the sampler.
<u>Jaw Shape, Design, and Cut</u>	
Franklin-Anderson	Poor. During the first stages of closure and when under the greatest pressure of springs and weight, the jaw shape loosely follows the arc of cut. However, the degree of fit becomes progressively worse as the closing pressure is reduced. Because each jaw is semicylindrical in shape, sample displacement is necessary within it if anything near maximum capacity is to be achieved.
Dietz-LaFond	Poor. As for Franklin-Anderson.
Birge-Ekman	Excellent. Jaw shape exactly follows arc of cut and almost no sample displacement occurs.
Petersen	Poor. Comments as for Franklin-Anderson, except that, instead of the reduction in closure pressure
(Continued)	

* After Sly.⁵

Table 2-1 (Continued)

Grab	Jaw Shape, Design, and Cut
Petersen (Continued)	being produced by slackening of tensional springs, the same result is effected by reduced leverage on the scissor arms mounted across the hinge line.
Ponar	Excellent. Jaw shape exactly follows arc of cut and almost no sample displacement occurs.
Shipek	Excellent. As for Ponar. In addition, the rotation of the bucket is extremely rapid. In most cases the rotational shear is far greater than the sediment shear strength, thus the cutting action is very clean (producing minimal disturbance), particularly in soft clays, muds, silts, and sands.
<u>Preservation and Protection from Washout</u>	
Franklin-Anderson	Fair, but the tightness of closure is largely dependent upon the lack of grains trapped between the edges of the jaws. Providing a tight fit between the two jaws is obtained, the sample is well shielded against washout. If the jaws are kept open by material trapped between the jaws, washout can be severe or total.
Dietz-LaFond	Fair. Comments as for Franklin-Anderson.
Birge-Ekman	Good, except when the sampler is used in very coarse or shelly sediment. Under these conditions, material may be trapped between the jaws, preventing their closure. In this case, washout may be severe. The jaws are so designed that they slightly overlap one another, thus a slight imperfection of closure can be tolerated.
Petersen	Good. Comments as for Birge-Ekman.
Ponar	Good. Comments as for Birge-Ekman. In addition to the overlap jaws, this sampler has a pair of metal side plates, mounted close to the moving side faces of the jaws. These plates further reduce the possibility of washout.
Shipek	Excellent. The great advantage of the Shipek, over all of the other samplers described, is

(Continued)

(Sheet 2 of 4)

Table 2-1 (Continued)

Grab	Preservation and Protection from Washout
Shipek (Continued)	that the bucket closes with its separation plane aligned in the horizontal rather than in the vertical. Good samples can be retrieved even when bucket closure is prevented by pebbles or similar material, even 2 to 5 cm across. With the bucket properly rotated, washout is completely avoided.
	Stability
Franklin-Anderson	Fair. Despite the weight of this grab, it tends to "stream" at an inclined angle under conditions of rapid ship drift or fast water flow. Provided lowering conditions are calm and stable, the sampler will hold upright during the initial sampling process; if, however, the line is allowed to slack, the sampler will fall over.
Dietz-Lafond	Poor. This sampler is very sensitive to "streaming" and will rarely operate in the vertical position unless used in ideal conditions. Its tendency to maintain an inclined attitude during descent sometimes results in a failure to trigger.
Kirge-Ekman	Fair. Despite the light weight of this sampler and its tendency to "stream," its wide base gives good stability and stance once it has come to rest on the sediment floor. Under poor sampling conditions, however, it becomes impossible to operate because: (a) the sampler, due to its light weight, is continually being lifted and dropped and "streamed" along the bottom, and (b) any slack in the line, particularly near the sampler, is likely to impede the proper function of the triggers' messenger weight. It tends to roll over after triggering on all but soft bottoms.
Petersen	Good. This is a heavy sampler with a wide base line (when the jaws are open). It maintains a near vertical descent under all conditions, but after sampling it tends to fall over (unless on a soft bottom).

(Continued)

(Sheet 3 of 4)

Table 2-1 (Concluded)

Grab	Stability
Ponar	Very good. Comments as for Petersen; because of its weight and wide baseline (when jaws are open), this grab has a good vertical descent under most conditions and has a stable stance on the bottom. The presence of the fixed side plates prevents the grab from falling over after jaw closure and helps in preserving a near perfect bottom sample.
Shipek	Excellent. Despite the large size of this sampler, its weight ensures a near perfect vertical descent even under conditions of rapid drift or fast water flow. The sampler is also very stable even on bottom slopes 20 degrees or more. This stability ensures the minimum possible disturbance of the sample material.

Table 2-2

Operational Suitability of Corers and Grab Samplers*

Sampler	Characteristics
Benthos Gravity Corer	Cores of 3 m or less in soft clays, muds, or sandy silts. Particularly suitable for studies of the sediment/water interface, for studies on depositional sediment structures.
Alpine Gravity Corer	Cores of 2 m or less in almost all sediment types. The rugged nature of this corer lends itself to general usage. For studies involving sediment structure or large volumes of material, the corer is unsuitable; for studies of a pilot nature, or to prove the suitability of an area for piston coring, this gravity corer is excellent.
Phleger Corer	Cores of 0.5 m or less, in almost all sediment types. Particularly suited to bottom materials containing a high percentage of fibrous organic material. The low cutter angle, the narrow wall thickness and high point loading, and the extremely sharp cutter, make it very suitable for sampling shallow lacustrine and estuarine deposits, marsh deposits, and thin peat beds.
Multiple Corers	Still under investigation.
Franklin-Anderson Grab	Suitable for obtaining material for bulk sample analysis. Works best in soft clays, muds, silts, and sands. Will occasionally obtain a good gravel sample. Material of no use for structural or other specific analyses.
Dietz-LaFond Grab	Can be used for general sampling but not recommended for any particular use. Of all the samplers tested, this pattern proved to be the least suitable.
Birge-Ekman Dredge	Suitable for soft clays, muds, silts, and silty sands. This sampler should be used under calm water conditions, typically in small lakes or restricted areas. The lack of sample disturbance, square cross section, and moderate penetration make this sampler suitable for detailed studies (i.e. biological and geochemical) of the top 2 to 3 cm of bottom sediment. Because of its light weight and easy handling, it is well suited to small boat operations.

(Continued)

* After Sly.⁵

Table 2-2 (Concluded)

Sampler	Characteristics
Petersen Grab	This sampler, like the Franklin-Anderson, is suitable for taking bulk sample material in most types of sediment. It is quite unsuited for studies of detailed and specific sediment properties, though it is perhaps a little more successful in taking gravel samples. Either of these two samplers (Petersen or Franklin-Anderson) will do well as a general purpose bulk sampler.
Ponar Grab	An excellent general purpose bottom sampler. In practice it operates better than either the Petersen or Franklin-Anderson over the full range of bottom types. It can also obtain bottom samples with little or no disturbance and with the protecting screens removed or folded back, direct access can be had to the sediment surface of the sample. Such access to an undisturbed sample makes it suitable for geochemical, sedimentological, biological, and structural studies. Because of the large sample volume and its relatively undisturbed state, this sampler is very suitable for population studies of the bottom sediment fauna.
Shipek Bucket Sampler	An excellent general purpose sampler, though perhaps a little heavy for small boat operation. This sampler is capable of working with almost equal success on all types of bottom material. It provides a sample even less disturbed than the Ponar, making it the most suitable sampler (under test) for detailed geological studies of the sediment surface. The sampler volume is significantly less than that of the Ponar, and the quantity of material sampled at maximum cutting depth is also less than the Ponar. These two points may, therefore, favor the Ponar for certain biological (population) studies. On the other hand, the rapid rotation of the Shipek bucket, as opposed to the much slower closure of the Ponar's jaws, may make it more suitable for sampling sediment containing a significant population of nonsessile forms.

manager is responsible for making these decisions using the general guidance offered in Section 1.

The responsibility of the field personnel is to implement a collection program that minimizes sample contamination due to the process of sampling. Sampling locations should be approached from the downwind or downcurrent side to avoid effects due to the sampling vessel itself or wastes from the vessel.¹ In addition, a sampling hierarchy should be established to prevent undue sample contamination as a consequence of the previous sampling effort. Surface water samples should receive the highest priority, followed by water from increasing depth. The last samples to be obtained at each station are sediment samples because of the potential for loss as they are retrieved through the water column.

Sample Handling

The method of sample handling after collection and prior to analysis is determined by the type of test to be run and the specific parameter being quantified. There are three types of chemical tests being considered in this manual: standard elutriate test, bulk analysis, and elemental partitioning. Each test has certain sample handling requirements that are summarized in schematic form in Figure 2-1.

Each test provides different information on the sample and, therefore, requires different handling. The elutriate test indicates the ability of chemical constituents to migrate from the solid phase to the liquid phase.^{2,10} Since chemical forms migrate differently, sample alterations due to drying, freezing, or air oxidation are to be avoided and the test should be completed as soon as possible (preferably within 1 week of collection).² Elemental partitioning provides information on the distribution of chemical constituents among several defined sedimentary chemical phases.¹⁰⁻¹³ Samples should be processed as quickly as possible and sample alterations due to drying, freezing, or air oxidation are to be avoided. The third test considered is bulk analysis, which provides information on the total concentration

of chemical constituents in the sample.² Since chemical speciation is less important for this test, greater flexibility in sample storage is acceptable with this test, provided the processes of freezing and/or drying do not cause the chemical degradation or volatilization of chemical contaminants of interest.

An examination of Figure 2-1 reveals that all three tests can be run on dredge, core, or sectioned core samples. The difference is that more stringent sample storage requirements must be met for the elutriate test and elemental partitioning. While there is greater flexibility in storing bulk analysis samples, there is less flexibility in sample utility after the choice is made. That is, a sample stored in a dried or frozen state can be analyzed for total content but cannot be used in the elutriate test or elemental partitioning, while a sample properly preserved for either of the latter tests can also be used in bulk analysis testing. In addition, samples stored for the elutriate test or elemental partitioning also can be used for toxicity or bioassay testing. While guidance for toxicity testing is beyond the scope of this manual, it is important to realize that toxicity is influenced by chemical form, in addition to other factors, and that certain storage practices, such as sample drying and freezing, can alter the toxicity of a sample.¹⁴

A sample to be used in an elutriate test or a sediment fractionation analysis should be stored under conditions that provide for original moisture, refrigeration, and minimum atmospheric contact. However, a sample for bulk analysis may be stored in a wet, dried, or frozen state. The selection among these options should be based primarily on the specific chemical analysis to be completed. Guidance for selection between the three methods of bulk analysis sample storage is summarized in Table 2-3.

The longest list of parameters is associated with sediment samples stored in a wet condition. These conditions are most similar to in situ conditions and, therefore, subject to a smaller force to produce a change. Drying or freezing of a sample can alter the total concentration of some constituents as well as the chemical speciation of others. Parameters in this category are biological oxygen demand

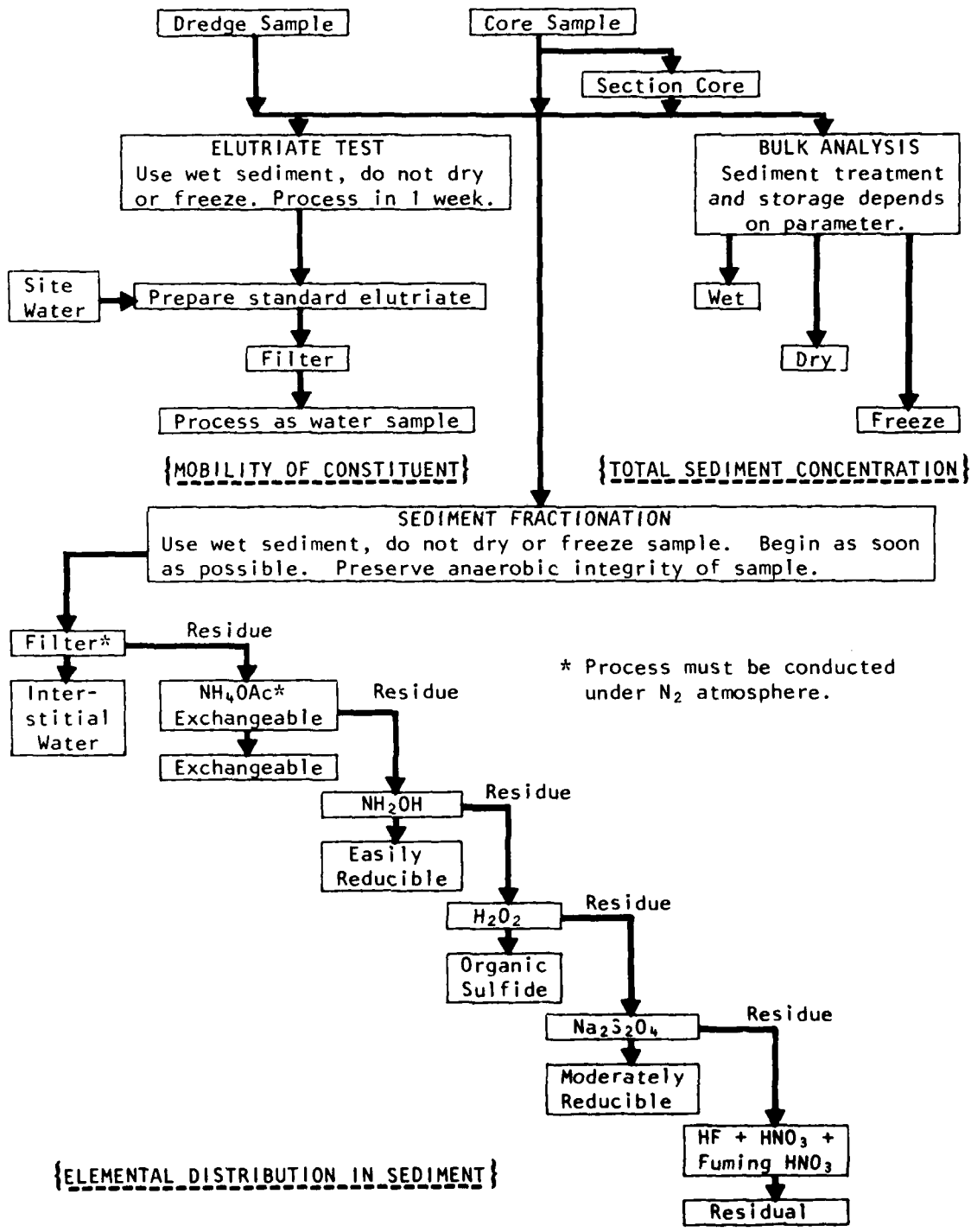

Figure 2-1. Comparative methods of sediment sample handling

Table 2-3
Recommended Method of Sample Storage as a Function of Bulk Sediment Analyses to be Performed

	Wet		Dry		Freeze
CEC	NH ₃		Particle size*	Al	Particle size*
Cl ₂ Demand	NO ₂ ⁻		TOC	As	TOC
BOD	NO ₃ ⁻		TIC	Cd	TIC
COD	Org-N		PCB's	Ca	O & G
SOD	TKN		Pesticides	Cr	PCB's
Carbamates	O & G		Org-P	Cu	Pesticides
pH	PCB's		Total-P	Fe	Phenolics
SRP	Org-P		PAH**	Pb	Org-P
Redox	Total-P		Mercury†	Mg	Total-P
Total solids	PAH			Mn	PAH
Volatile solids	Hg			Mo	Mercury
Sulfides	Al			Ni	
Phenoxy acids	As			Se	
Particle size	Cd			Zn	
TOC	Ca				
TIC	Cr				
Pesticides	Cu				
Phenolics	Fe				
Specific Gravity	Pb				
	Mg				
	Mn				
	Mo				
	Ni				
	Se				
	Zn				

* Dispersed particle size probably not affected by drying or freezing.
 Apparent particle size may be affected.

** PAH = polycyclic aromatic hydrocarbons.

† Mercury may be lost if sample is dried at too high a temperature.

(BOD), chemical oxygen demand (COD), sediment oxygen demand (SOD), and chlorine demand. Since drying or freezing can result in sample oxidation and, hence, a reduction of these parameters, these tests should be run on wet samples. Other variables that should be quantified on wet samples are cation exchange capacity (CEC), carbamates, pH, Eh (redox potential), soluble reactive phosphate (SRP), total solids, volatile solids, sulfides, and phenoxy acids. The fact that analytical results can be altered due to sample oxidation (affects sulfide, SOD, COD, and Eh results), sample drying (CEC, pH), sample volatility (phenols, volatile solids), and constituent instability (carbamates) also would indicate that these constituents should be analyzed as soon as possible after sample collection.

Parameters that can be run on dried or frozen samples are metals, stable organics, total nutrients, and minerals. However, there are precautions that should be considered. For example, volatile substances (Hg, Se, some phenolics and organics, and possibly ammonia) may be lost if the sample is dried at too high a temperature. Another borderline parameter is particle size. If a dispersed particle size is to be determined, then drying or freezing should not affect the sample. However, apparent particle size may be altered by these storage procedures.

Sample Preservation

It would be ideal if samples could be analyzed immediately. However, this is seldom possible because of the number of samples to be collected, the fact that all analytical equipment cannot be satisfactorily operated in the field, and manpower limitations. Therefore, samples should be treated when necessary with appropriate preservatives to minimize chemical changes between the time of collection and the time of analysis.

It cannot be stressed too strongly that a sample will be subject to chemical, biological, and physical changes after collection.¹⁵ The use of sample preservatives does not halt these changes but serves to slow or minimize them and, thus, provides more time to

complete the required analyses. Approaches that have been used to preserve samples are refrigeration, pH adjustment, addition of chemicals, and sample extraction. The selection of appropriate preservation techniques also depends on the specific analysis to be conducted. Recommended techniques for water sample preservation are summarized in Table 2-4.

It should be apparent that there is no universal preservative and that a technique used to minimize the changes in one parameter may alter the concentration or interfere in the analysis of another substance.¹⁶ This problem can be overcome by splitting the sample at the time of collection. Individual aliquots of the sample can then be preserved as required without interfering with other analyses. In general, the number of subsamples that will be required will be equal to the number of different preservatives that must be used.

A similar listing of preservation techniques for specific chemical constituents in sediment samples has not been prepared. This results from the fact that sediment preservatives have not been as thoroughly evaluated as water sample preservation techniques. Also, the preservative would have to be thoroughly mixed with the sample, which would result in the destruction of sample integrity. However, as a general rule, sample containers should be selected based on the guidance provided for water samples (Table 2-4). That is, aliquots for metal or nutrient analysis may be stored in plastic or glass containers; but aliquots for organic analysis should be stored in glass containers with teflon-lined caps. In addition, the following approach(es) is (are) recommended, depending on the test to be performed:

- a. Elutriate test. Sediment samples should be stored wet, at 4°C, and in an airtight container.² The elutriate test procedure should be initiated within 1 week of sample collection. The standard elutriate that results from this procedure can then be analyzed immediately or treated as a water sample and split and preserved, as discussed earlier.
- b. Sediment fractionation. Sediment samples scheduled for fractionation analysis should also be stored wet, at 4°C, and in an airtight container. The last requirement

Table 2-4
Recommended Water Sample Preservation Techniques¹⁵

Parameter	Container*	Sample Volume ml	Preservative	Storage Time
Total organic carbon	P, G	100	H ₂ SO ₄ to pH < 2 4°C	24 - 48 hr
Total inorganic carbon	P, G	100	Air Seal 4°C	0**
Chlorine demand	P, G		None	0
Aluminum	P, G	100-200†	HNO ₃ to pH < 2	6 mo
Arsenic	P, G		HNO ₃ to pH < 2	6 mo
Cadmium	P, G	100-200†	HNO ₃ to pH < 2	6 mo
Calcium	P, G	100-200†	HNO ₃ to pH < 2	6 mo
Chromium	P, G	100-200†	HNO ₃ to pH < 2	6 mo
Copper	P, G	100-200†	HNO ₃ to pH < 2	6 mo
Iron	P, G	100-200†	HNO ₃ to pH < 2	6 mo
Lead	P, G	100-200†	HNO ₃ to pH < 2	6 mo
Magnesium	P, G	100†	HNO ₃ to pH < 2	6 mo
Manganese	P, G	100-200†	HNO ₃ to pH < 2	6 mo
Mercury	G	500	HNO ₃ to pH < 2	2 wk
Molybdenum	P, G	100-200†	HNO ₃ to pH < 2	6 mo
Nickel	P, G	100-200†	HNO ₃ to pH < 2	6 mo
Selenium	P, G		HNO ₃ to pH < 2	90 days
Zinc	P, G	100-200†	HNO ₃ to pH < 2	6 mo
Ammonia-nitrogen	P, G		H ₂ SO ₄ to pH < 2 4°C	24 hr
Nitrate-nitrogen	P, G		H ₂ SO ₄ to pH < 2 4°C	24 hr

(Continued)

* P = plastic; G = glass.

** One reference indicates TIC may be preserved for 3 mo in a sealed bottle with HgCl₂ (W. S. Wong. Deep Sea Research 17:9-17 (1970)).

† Sample can be used for other metal analyses.

(Sheet 1 of 3)

Table 2-4 (Continued)

Parameter	Container	Sample Volume ml-ℓ	Preservative	Storage Time
Nitrite-Nitrogen	P, G		H ₂ SO ₄ to pH < 2 4°C	24 hr
Organic-Nitrogen	P, G		H ₂ SO ₄ to pH < 2 4°C	24 hr
Total Kjeldahl Nitrogen	P, G		H ₂ SO ₄ to pH < 2 4°C	24 hr
Oil and Grease	G		H ₂ SO ₄ or HCl to pH < 2 4°C	24 hr
Biochemical oxygen demand	P, G	300 ml-2 ℓ	4°C	6 hr
Chemical oxygen demand	P, G	200 ml	H ₂ SO ₄ to pH < 2 4°C	7 days
PCB's	G	2 ℓ	4°C	
Organochlorine pesticides	G	1 ℓ	4°C	
Chlorinated phenoxy acid herbicides	G	1 ℓ	H ₂ SO ₄ to pH < 2 4°C	
Organophosphates and carbamates	G	1 ℓ	H ₂ SO ₄ to pH < 3 10 g Na ₂ SO ₄	
Phenolics	G	500 ml-1 ℓ	0.1-1.0 g CuSO ₄ H ₃ PO ₄ to pH < 4 4°C	24 hr
Soluble reactive phosphates	P, G		Filter 4°C	24 hr
Organic phosphate				
Total phosphorus	P, G		4°C	7 days
Redox potential	P, G	100 ml	None	None
pH	P, G	100 ml	None 4°C	6 hr

(Continued)

(Sheet 2 of 3)

Table 2-4 (Concluded)

Parameter	Container	Sample Volume ml	Preservative	Storage Time
Total solids	P, G	200††	4°C	7 days
Volatile solids	P, G	200††	4°C	7 days
Sulfides	P, G		2 ml ZnOAc	24 hr
Polynucleated aromatic hydrocarbons	G			

†† Sample can be used for total solids and volatile solids.

(Sheet 3 of 3)

is especially important since the first two steps of the fractionation procedure must also be carried out under a nitrogen atmosphere.¹⁴ Fractionation procedures should commence as soon as possible and, preferably, no later than 1 week after sample collection. As the operationally defined fractions are prepared, they may be analyzed immediately or preserved for specific constituents and analyzed at a later date.

- c. Bulk analysis. There is more flexibility in selecting a storage technique for samples to be analyzed for total concentration. The reason is that, unlike the previous two procedures which measure specific forms of chemicals in the sediments, bulk analysis measures the total content of the sample. Therefore, the results are not affected by processes such as oxidation and air drying that alter the species distribution of chemicals in the samples. The choice between storing a sample in a wet condition, dried condition, or a frozen condition should be based largely on the analyses to be run as illustrated in Table 2-3 and discussed previously.
- d. Tissue analysis. There are two factors that must be considered when it is necessary to store biological tissue. The first factor is the stability of the specific chemical entity. The second factor is the stability of the tissue itself since analytical results are expressed on a wet weight and/or a dry weight basis. Thus, concentrations can be altered if the tissue is dehydrated during storage even though the chemical of interest may be stable. A suggested approach would be to record the appropriate wet and/or dry weights of the tissue samples as soon as possible. Tissue samples should be digested (for inorganic constituents) or extracted (for organic constituents) and the digest or extract can then be stored according to the guidance presented in Table 2-4.

Quality Control

Objectives

An integral part of any sampling program must be a quality assurance or control program. The objectives of this program should be to determine the quality of the data (accuracy and precision) and to control the quality of the data (variability). The responsibility for this program must be shared between the field and laboratory personnel since quality control begins with sample collection and not

sample analysis.¹⁷ It is important that field personnel be made aware of the fact that the greatest potential for sample contamination occurs during the preanalysis steps of sample collection, handling, preservation, and storage.

There are several functions that can be performed by field personnel to assist in an overall quality control program. These include:¹⁷

- a. Providing a representative sample for analysis.
- b. Providing replicate samples to define variation at a single point.
- c. Providing a sufficient amount of sample to allow detection.
- d. Spiking occasional samples to correct for sample decay between collection and analysis.
- e. Initiating analysis or appropriate storage procedures immediately after collection.
- f. Properly labeling and recording the dates and location of sample collection.

The need to include all of these functions will depend on the specific purpose of the project. As discussed in Section 1, representativeness is a difficult property to assess. Also, replicate sampling at each location may be desirable but not essential for all projects. However, collection of sufficient sample, utilization of appropriate storage procedures, and proper sample identification should be an integral part of every sample collection effort.

Laboratory personnel also have certain functions that must be satisfied in order to complete the quality control program.¹⁷ Some of the more obvious duties are:

- a. Using acceptable techniques for analysis.
- b. Completing the analysis immediately (ideally) or within prescribed storage limits that are parameter specific.
- c. Performing replicate analysis on approximately 5 to 10 percent of samples processed.
- d. Adding standard solution spikes to approximately 5 to 10 percent of samples processed and determining recovery.
- e. Using an internal laboratory standard to check performance of analytical method.

- f. Analyzing externally prepared reference and performance (unknown) samples on a routine basis.

A more detailed list of ideal quality control activities that was prepared by Delfino¹⁸ is presented in Table 2-5.

Work load

It is suggested that a quality control program should consist of approximately 15 to 20 percent of the total analytical work load.

This should consist of the following:

- a. Five percent duplicate sample collection.
- b. Five percent replicate determinations.
- c. Five percent spike recovery.
- d. Five percent external reference, field blanks, or unknown samples and sample splitting with other laboratories.

These are discussed in more detail in the following paragraphs.

Duplicate samples. At stations selected at random, duplicate samples are collected from two sets of field equipment installed at the site, or duplicate grab samples are collected. This provides a check of sampling equipment and technique for precision.

Split samples. A collected sample is split and each aliquot is analyzed as an independent sample. The samples may be reanalyzed by the same laboratory or analyzed by two different laboratories as a check of the analytical procedures.

Spiked samples. Known amounts of a particular constituent are added to an actual sample or to blanks of deionized water at concentrations at which the accuracy of the test method is satisfactory. The amount added should be coordinated with the laboratory. This method provides a proficiency check for accuracy of the analytical procedures.

Sample preservation blanks. Acids and chemical preservatives can become contaminated after a period of use in the field. The sampler should add the same quantity of preservative to some distilled water as normally would be added to a water or sediment sample. This preservative blank is sent to the laboratory for analysis of the same parameters that are measured in the sample and values for

Table 2-5
Ideal Control Activities for Documenting
the Validity of Laboratory Data*

Verify calibration curves.

Confirm instrumental calibrations (wavelength, temperatures, etc.).

Monitor precision by performing replicate analyses on ca. 5 to 10 percent of samples processed.

Perform multiple replicates during the day and compute standard deviation; if possible, compute relative standard deviation when dealing with wide ranges of concentrations.

Document recovery by adding standard solution spikes to ca. 5 to 10 percent of samples processed; determine percent recovery of spikes.

Use an internal laboratory standard to trace performance on a given analytical method; match matrix as closely as possible to sample(s).

Split samples with other laboratories performing similar analyses, at least on a quarterly basis.

Analyze an externally prepared performance sample [e.g. EPA, National Bureau of Standards (NBS), etc.] at least quarterly.

Analyze an externally prepared performance sample (unknown) from EPA or other source at least annually.

Develop quality control charts for precision and recovery performance; use charts to monitor daily laboratory performance; generate with a computerized data handling system, if possible.

Develop correlation data between analyses of similar meaning and use as cross-checks on validity of results, e.g., conductivity and total dissolved solids, turbidity and total suspended solids, TOC** and BOD/COD, equivalent charge balance.

Calibrate analytical balances when irreproducibility is noted; service balances on an annual basis.

Rotate chemical inventory to eliminate older chemicals and reagents.

Develop replacement schedule for standard solutions; discard sooner if calibration curves change and this cannot be related to instrumental variation.

Develop instrument maintenance records; enter all service, adjustments, etc., including problem diagnosis and resolution; state if data were reported when instrument was out of calibration and, if so, explain

(Continued)

* Perform on a daily basis unless noted otherwise; after Delfino.¹⁸
** TOC = total organic carbon.

Table 2-5 (Concluded)

disposition of the data.

Calibrate thermometers vs. an NBS-certified thermometer.

Validate all data entered into computer storage and retrieval systems;
verify by double entry ca. 5 to 10 percent of all entries.

Record data in bound notebooks; institute supervisory inspection of data
prior to release external to laboratory.

Scan current literature to maintain awareness of research progress and
technical aids; subscribe to EPA documents, including American Quality
Control newsletter.

the blank are then subtracted from the sample values. Liquid chemical preservatives should be changed every 2 weeks or sooner if contamination increases above predetermined levels.

It is also essential that reagent blanks or distilled water and solvents used in the laboratory be routinely analyzed for contamination. These values are also subtracted from the determined sample values. Reagents, solvents, and distilled water should be purified or replaced if contamination exceeds predetermined levels.

Present limitations

The theory of quality control was developed for an industrial application approximately 50 years ago to evaluate the quality of a product. Unfortunately, there are differences between environmental samples and industrial products that make it difficult to satisfactorily apply industrial quality control techniques. Five major components that contribute to total error in an environmental sample are: site selection, sampling, measurement method, reference sample, and data handling error.¹⁹ The largest error, particularly for sediment samples, is site selection, over which there is no control. In addition, quality control statistics are dependent upon the true sample value being known, which is not generally the case with environmental samples. Since there is no expected value for a randomly selected sample, much more reliance must be placed on standard and spike recovery, and replicate determinations, to indirectly evaluate the accuracy of testing methodology.¹⁷

Types of Chemical Tests

Three types of chemical tests are considered for analysis of dredged and/or fill material samples: standard elutriate test, sediment fractionation, and bulk or total analysis. The selection of any one of these tests or combination of these tests should be based on the purpose of the study as discussed in Section 1.

The elutriate test is a short-term, sediment-leaching procedure. It consists of agitating a known volume of sediments/fill

material with a known volume of site water. The suspension is then filtered and the filtrate analyzed. Thus, the test provides an indication of the chemical constituents likely to be released to the water column during a disposal/filling operation.^{2,20,21} Since the sediment-to-liquid ratio used in the test is based on hydraulic dredging ratios, results from the elutriate test will probably overestimate the release from less dynamic dredging techniques such as hopper or clamshell dredging.

The purpose of the elutriate test is to provide information on the potential effects of a disposal operation on water quality. Results can then either be used to estimate the extent of a resource that will be influenced by the proposed discharge or used to compare the results to appropriate water quality criteria.

The first option would be preferred because it provides information on the amount of the receiving water necessary to assimilate the proposed discharge and whether other critical uses such as spawning grounds or water intakes may be impacted. This is accomplished by determining whether the required mixing zone overlaps with other areas of specific water use.²

The second option is less desirable for two reasons. First, a comparison of elutriate test concentrations with criteria would be overly conservative because site dilution is not included.²² Second, water quality criteria have an implied exposure time ranging from 96 hr to many months, while dredged material perturbations persist for 30 min to 2 hr. Since disposal plumes exist for shorter time periods, a direct comparison to criteria would be even more conservative. Because of the nature of the comparisons, an elutriate test result less than established criteria would indicate that adverse water quality impacts would not be expected. However, an elutriate test result exceeding established criteria would not necessarily imply that adverse water quality impacts would occur.

Elemental partitioning or sedimentation fractionation studies are the most complex of the tests considered in this manual. They have only been used in studies involved with metals and nutrients (carbon, nitrogen, phosphorus) to date.^{10-12,23} The procedure

consists of exposing the sample to a series of leaching agents of increasing strength. The first step consists of centrifugation/ filtration of the sample to isolate interstitial water. The solid residue is then sequentially leached with ammonium acetate, hydroxylamine, hydrogen peroxide, dithionate, and a hydrofluoric acid-nitric acid mixture.¹⁰⁻¹² Results provide an indication of the distribution of chemicals in sediments and fill material and the harshness required to mobilize that constituent.¹¹⁻¹³

93. At this time, there is no simple or universal method of evaluating fractionation studies. When fractionation results were correlated with elutriate test results,¹¹ the highest degree of correlation occurred between elutriate concentrations and the interstitial and exchangeable phases. This suggests that the elutriate test is a measure of the most mobile sediment constituents. In another study, no relationships were observed between chemical fractionation results and biological uptake of metals.²³ A third study correlating long-term release with fractionation results demonstrated the highest degree of correlation with elutriate and interstitial water concentrations.¹⁰ The number of correlations decreased markedly as the strength of the extract increased. Results demonstrate the complexity of evaluating the potential effects of chemicals in sediments and suggest that the more tightly bound substances are less likely to create environmental problems.

94. Bulk analysis results provide information on the total concentration of chemical constituents in the samples being analyzed. The procedure consists of a strong acid digest or an organic solvent extraction of the sample. Because specific chemical forms or chemical distribution are not of importance with this test, bulk analysis generally allows more flexibility in sample handling.

95. Total analysis results can be used to calculate the mass (concentration \times volume) of a specific constituent involved in a dredging/filling operation. Results also can be used for a crude comparison of sediments and/or fill material with the proposed disposal site. However, it is recommended that bulk analysis results not be used to evaluate potential environmental impacts of a proposed disposal operation. References cited earlier demonstrated little, if any,

relationships between total sediment concentration and biological uptake or changes in water quality. Also, a review of the technical literature indicated no correlations between total composition and sedimentary effects on water quality.²⁴

Elutriate test

The elutriate test is a simplified simulation of the dredging and disposal process wherein predetermined amounts of dredging site water and sediment are mixed together to approximate a dredged material slurry.^{2,20} The elutriate in the supernatant resulting from the vigorous 30-min shaking of one part sediment from the dredging site with four parts water (vol/vol) collected from the dredging site followed by a 1-hr settling time and appropriate centrifugation and 0.45 μ filtration. Thus, it will be necessary to collect both water and sediment samples to perform the elutriate test. When evaluating a dredging operation, the sediment should be collected at the dredging site and the water should be collected at the dredging and the disposal site. To evaluate a fill material activity, samples should be collected from the source of the fill material and the water should be collected from the disposal site.

Water sample collection. Collection should be made with an appropriate noncontaminating water sampling device. Either discrete samplers such as Kemmerer or Van Dorn samplers or continuous collectors such as submersible pumps may be used. The volume of water required will depend on the number of analyses to be performed. For each sample to be subjected to elutriate testing, it is suggested that a minimum of 4 l be collected at the disposal site and 8 l be collected at the dredging site to evaluate a dredging operation and/or 12 l be collected at the disposal site to evaluate a fill material disposal operation. This will provide 4 l of water for analyses and sufficient water to prepare triplicate 3-l elutriates. (Each elutriate should yield 2.0 to 2.2 l of standard elutriate for analysis.) If the samples are to be analyzed for trace organics or a large number of constituents, a proportionately larger initial sample should be collected.

Samples must be stored in glass containers if trace organic analyses are to be performed. Generally, either plastic or

glass containers may be used for other parameters. The samples should be maintained at 4°C until analyzed but never frozen. The storage period should be as short as possible to minimize changes in the characteristics of the water. Disposal site water should be analyzed or split and preserved immediately. The remainder of the water should be used in the elutriate test, which should be processed within 1 week of collection.

Sediment sample collection. Samples should be taken from the fill or the dredging site with a grab or a corer. Approximately 3 l of sediment or fill material would provide sufficient sample to prepare triplicate 3-l elutriates. Again, if the resultant standard elutriates are to be analyzed for trace organics or a large number of constituents, a proportionately larger initial sample should be collected.

Samples may be stored in plastic bags, jars, or glass containers. However, if trace organic analyses are to be performed, glass containers with teflon-lined lids are required. A special precaution that must be taken with sediment samples is to ensure that the containers are completely filled with sample and that air bubbles are not trapped in the container. This step is necessary to minimize sample oxidation that could influence elutriate test results.^{2,22}

The samples should be stored immediately at 4°C. They must not be frozen or dried prior to use. The storage period should be as short as possible to minimize changes in the characteristics of the sediment. It is recommended that samples be processed within 1 week of collection.

Apparatus. The following apparatus are required to perform the elutriate test. Prior to use, all glassware, filtration equipment, and filters should be washed with 5 to 10 percent (or stronger) hydrochloric acid (HCl) and then rinsed thoroughly with deionized water. The necessary apparatus include:

- a. Acid-rinsed plastic bottles for collection of water samples.
- b. Plastic jars or bags ("Whirl-Pak," plastic freezer containers, etc.) for collecting dredged or fill material samples.

- c. Laboratory shaker capable of shaking 2-l flasks at approximately 100 excursions/minute. Box type or wrist-action shakers are acceptable.
- d. Several 1-l graduated cylinders.
- e. Large (15 cm) powder funnels.
- f. Several 2-l, large-mouth graduated Erlenmeyer flasks.
- g. Vacuum or pressure filtration equipment, including vacuum pump or compressed air source, and an appropriate filter holder capable of accomodating 47-, 105-, or 155-m-diameter filters.
- h. Membrane filters with a 0.45- μ pore-size diameter. The filters should be soaked in 5 M HCl for at least 2 hr prior to use.
- i. Centrifuge capable of handling six 1- or 0.5-l centrifuge bottles at 3000 to 5000 rpm. International Model K or Sorval Super Speed are acceptable models.
- j. Wide-mouth, 1-gal capacity glass jars with teflon-lined screw-top lids for use as sample containers when samples are to be analyzed for trace organics. (It may be necessary to purchase jars and teflon sheets separately; in this case, the teflon lid liners may be prepared by the laboratory personnel.)

Test procedure. The stepwise test procedure is given below:

- a. Subsample a minimum volume of 1 l each of dredging site and disposal site water. If it is known in advance that a large number of measurements are to be performed, the size of each subsample should be increased to meet the anticipated needs.
- b. Filter an appropriate portion of the disposal site water through an acid-soaked 0.45- μ pore-size membrane filter that has been prerinsed with approximately 100 ml of disposal site water. The filtrate from the rinsing procedure should be discarded.
- c. Analyze the filtered disposal site sample as soon as possible. If necessary, the samples may be stored at 4°C after splitting and the appropriate preservatives have been added (Table 2-4). Filtered water samples may also be frozen with no apparent destruction of sample integrity.
- d. Repeat steps a, b, and c with dredging site water. This step is omitted with a fill material sample.
- e. Subsample approximately 1 l of sediment from the well-mixed original sample. Mix the sediments and unfiltered dredging site water in a volumetric sediment-to-water ratio of 1:4 at room temperature (22 \pm 2°C). This is best done by the method of

volumetric displacement.²³ One hundred milliliters of unfiltered dredging site water is placed into a graduated Erlenmeyer flask. The sediment subsample is then carefully added via a powder funnel to obtain a total volume of 300 ml. (A 200-ml volume of sediment will now be in the flask.) The flask is then filled to the 1000-ml mark with unfiltered dredging site water, which produces a slurry with a final ratio of one volume sediment to four volumes water.

This method should provide 700 to 800 ml of water for analysis. If the analyses to be run require a larger volume of water, the initial volumes used to prepare the elutriate slurry may be proportionately increased as long as the solid-to-liquid ratio remains constant (e.g. mix 400 ml sediment and 1600 ml unfiltered dredging site water). Alternately, several 1-ℓ sediment/dredging site water slurries may be prepared as outlined above and the filtrates combined to provide sufficient water for analysis. The procedure continues as follows:

- f. (1) Cap the flask tightly with a noncontaminating stopper and shake vigorously on an automatic shaker at about 100 excursions per minute for 30 min. A polyfilm-covered rubber stopper is acceptable for minimum contamination.
- (2) During the mixing step given above, the oxygen demand of the dredged material may cause the dissolved oxygen concentration in the elutriate to be reduced to zero. This change can alter the release of chemical contaminants from dredged material to the disposal site water and reduce the reproducibility of the elutriate test.²¹ If it is known that anoxic conditions (zero dissolved oxygen) will not occur at the disposal site or if reproducibility of the elutriate test is a potential problem, the mixing may be accomplished by using a compressed air-mixing* procedure instead of the mechanical mixing described in Step f (1). After preparation of the elutriate slurry, an air-diffuser tube is inserted almost to the bottom of the flask. Compressed air should be passed through a deionized water trap and then through the diffuser tube and the slurry. The flow rate should be adjusted to agitate the mixture

* This procedure can cause the loss of highly volatile chemical constituents. If volatile materials are of concern, compressed air mixing should not be used.

vigorously for 30 min. In addition, the flasks should be stirred manually at 10-min intervals to ensure complete mixing.

- g. After 30 min of shaking or mixing with air, allow the suspension to settle for 1 hr.
- h. After settling, carefully decant the supernatant into appropriate centrifuge bottles and then centrifuge. The time and revolutions per minute during centrifugation should be selected to reduce the suspended solids concentration substantially and, therefore, shorten the final filtration process. After centrifugation, vacuum or pressure filter approximately 100 ml of sample through a 0.45- μ membrane filter and discard the filtrate. Filter the remainder of the sample to give a clear final solution (the standard elutriate) and store at 4°C in a clean, noncontaminating container in the dark. The filtration process is intended for use when the standard elutriate is to be analyzed for conventional chemical contaminants. When the elutriate is to be analyzed for organic contaminants and PCB's, filtration should not be used since organic concentrations can be reduced by sorption. Centrifugation should be used to remove particulate matter when the standard elutriate is to be analyzed for specific organics.
- i. Analyze the standard elutriate as soon as possible. If necessary, the samples may be stored at 4°C after splitting and the appropriate preservatives have been added.
- j. Prepare and analyze the elutriate in triplicate. The average of the three replicates should be reported as the concentration of the standard elutriate.

Sediment fractionation

Chemical constituents associated with sediments may be distributed in many chemical forms. The purpose of a fractionation procedure is to better define this distribution. This objective is achieved by leaching a sample with a series of successively harsher extraction agents. Reagents used in the procedure to be described below consist of interstitial water, ammonium acetate, hydroxylamine, hydrogen peroxide, citrate-dithionate, and hydrofluoric acid-nitric acid.

The premise of the fractionation procedure is that a specific geochemical phase is defined by a specific chemical

extraction agent. Thus, the ammonium acetate extract is referred to as the exchangeable phase, and the citrate-dithionate extract is referred to as the moderately reducible phase. These relationships have not been rigorously demonstrated and, therefore, the fractions are only operationally defined.

The use of fractionation results at this time appears to be limited to supporting other studies. That is, results have greater value in sediment research studies than in the regulatory decision-making process. Limited results with sediment fractionation data suggest a higher correlation with the more labile sediment phases (interstitial water, exchangeable phase) and elutriate test results¹¹ and long-term water quality changes.¹⁰

A major limitation of the fractionation procedure is that previous experience is limited to heavy metals and nutrients. A broad spectrum analysis of the individual fractions has been limited by small sample size, particularly the interstitial water fraction.

Sample collection. Samples should be collected with a grab or a corer. Because the distribution of sediment-associated chemicals can be altered by processes such as drying and oxidation, samples should be kept wet and exposure to the atmosphere should be minimized. Samples collected with a grab or dredge must be quickly transferred to a container and air bubbles must be excluded from the container. Corer samples should be sealed in the core liner and returned to the laboratory in an upright position. Previous studies have shown that a 15-cm section from a 7.5-cm-diameter core can provide sufficient material to perform fractionation studies for eight metals and four nutrients.¹¹

The samples should be stored immediately at 4°C. They must not be frozen or dried prior to use. The storage period should be as short as possible to minimize changes in the distribution of chemical constituents in the sediments. It is recommended that samples be processed within 1 week of collection.

Apparatus. The following apparatus is required to perform sequential partitioning procedure. Prior to use, all glassware, equipment, and filters should be washed with 5 to 10 percent nitric acid and rinsed thoroughly with deionized water. This list of

equipment includes:

- a. Plastic jars or bags ("Whirl-Pak," plastic freezer containers, etc.) for collecting *grab* or *dredge* samples or polyethylene liners for the collection of core samples.
- b. Glove box or disposable *glove bag*.
- c. Polarographic oxygen analyzer or alternate method to confirm the absence of oxygen in *glove bag*.
- d. Utensils for splitting cores and handling samples in the *glove bag*.
- e. 250-ml and 500-ml polycarbonate centrifuge bottles.
- f. Refrigerated centrifuge.
- g. Vacuum filtration apparatus.
- h. 150-ml and 120-ml polyethylene storage bottles.
- i. Blender or porcelain mortar and pestle.
- j. Top-loading balance.
- k. Weighing dishes.
- l. Digestion block or hot plate.
- m. Teflon beakers.
- n. 50-ml volumetric flasks.

Test procedure. A stepwise sediment fractionation procedure is given in the following paragraphs.

To begin the procedure, prepare a glove box or disposable *glove bag*. Flush the system with nitrogen gas and maintain a positive pressure nitrogen atmosphere. Oxygen-free conditions in the *glove bag* or box should be verified with a polarographic oxygen analyzer prior to sample processing. Initial sample handling and all steps in the interstitial water and ammonium acetate extractions should be conducted under a nitrogen atmosphere.

Acid wash all hardware to be used in the extractions in 6 N HCl and thoroughly rinse with distilled water to minimize sample contamination during processing.

The initial separation removes the interstitial water phase. This is accomplished by first placing the sealed sediment sample in the *glove bag*. After reestablishing the nitrogen atmosphere, extrude the sediment core from its liner into a flat plastic container. If the core is to be sectioned vertically, 15-cm sections of a 7.5-cm-diameter

core have been shown to provide sufficient material for the sequential fractionation procedure. Each core section should be split into halves with one half (approximately 300 cc) being used for the interstitial water testing and the remaining half used for all other analyses. Place the half section for the interstitial water analysis in an oxygen-free, polycarbonate 500-ml centrifuge bottle in the glove bag and seal. Centrifuge the sample in a refrigerated centrifuge (4°C) at 900 revolutions per minute ($\approx 13,000 \times g$) for 5 min. This should be sufficient to recover 40 percent of the total sediment water. After centrifugation, return the sample to the glove bag and vacuum filter the interstitial water through a 0.45- μ pore-size membrane filter. Transfer the filtered sample to an acid-washed polyethylene bottle and acidify to pH 1 with HCl for preservation.

If the sediment sample is not to be sectioned vertically, decant excess water and blend the core or dredge sample. Place approximately 300 cc of the blended sample in an oxygen-free, polycarbonate 500-ml centrifuge bottle and seal. Centrifuge this sample for 5 min at 900 revolutions per minute ($13,000 \times g$) in a refrigerated centrifuge (4°C) and then filter through a 0.45- μ pore-size membrane filter under a nitrogen atmosphere. The filtered sample may be analyzed immediately or split for preservation and storage.

The exchangeable phase is determined on the unused half of the wet sediment sample that was blended for interstitial water analysis. Blend the wet sediment with an electrically driven polyethylene stirrer contained in the glove bag. Remove a subsample of the homogenized sediment sample (blended core section, core, or grab sample) for percent solids determination.

Weigh a second subsample (approximately 20 g dry weight) of each homogenized sediment section into an oxygen-free, tarred, 250-ml centrifuge tube containing 100 ml deoxygenated 1 N ammonium acetate, producing a suspension with an approximate solid-to-liquid ratio of 1:5. Adjust the pH of the acetate solution to the pH of the surface sediments. Seal the samples and then place on a wrist-action shaker for 1 hr. Centrifuge the samples at 6000 revolutions per minute for 5 min and return them to the glove bag for further processing under

the nitrogen atmosphere. Filter the sample through 0.45- μ pore-size membrane filters, retaining both the filtrate and the solid residue.

The filtrate may be analyzed immediately or split and preserved for specific constituents, as discussed for water samples. This extract will also include the interstitial water components since a fresh blended sediment sample was used. Therefore, measured concentrations should be reduced to compensate for the interstitial water. This can be accomplished as:

$$\text{Wt exchangeable material} = (\text{Vol ext}) (\text{Conc ext}) - \frac{(\text{Wt Sample}) (1 - \% \text{ Solids})}{(\text{density water})} (\text{IWC}) \quad (3)$$

where

(Vol ext) = volume of ammonium acetate extract
(Conc ext) = analytical concentration in ammonium acetate extract
(Wt Sample) = wet weight of sample for ammonium acetate extraction
% Solids = percent solids in sample
(density water) = density of water at temperature of sample
(IWC) = interstitial water concentration of sample

The easily reducible phase is performed with the solid residue from the exchangeable phase determination. This step and all subsequent steps in the fractionation procedure can be conducted outside the glove bag. Add 50 ml N₂ sparged distilled-deionized water to the centrifuge tube containing the solid residue from the 1 N ammonium acetate extraction. Agitate the sample with a stainless steel spatula or a glass-stirring rod to ensure good washing efficiency. Centrifuge the suspension of 6000 revolutions per minute and discard the liquid phase. A portion of the solid residue will have to be set aside at this point for a redetermination of percent solids.

Blend the remaining sediment residue and transfer a 2-g (dry weight equivalent) subsample to a 250-ml Erlenmeyer flask. Add 100 ml of 0.1 M hydroxylamine hydrochloride-0.01 M nitric acid solution. The resultant suspension will have a solid-to-extractant ratio of approximately 1:50. Seal the sample and place the suspension on a wrist-action shaker (or equivalent) for 30 min. Centrifuge the sample

at 6000 revolutions per minute for 5 min. Decant and filter the liquid phase through 0.45- μ pore-size membrane filters. The filtrate may be treated as a water sample and analyzed immediately or split and preserved for specific constituents.

The solid residue is used in the organic and sulfide phase extraction. Wash the residue from the easily reducible phase with 50 ml distilled water. After agitating the suspension, centrifuge the sample at 6000 revolutions per minute for 5 min and discard the supernate. Subsample the residue for a percent solids determination so the organic and sulfide results can be expressed on a dry weight basis. Add 50 ml of 30 percent hydrogen peroxide to the washed residue and adjust the pH to 2.5 with HCl. (The purpose of the pH adjustment is to prevent any released metals from precipitating.) Digest the sample at 95°C for 6 to 8 hr. Add 100 ml of 1 N ammonium acetate buffered at pH 2.5 to the digestate and shake for 1 hr. Centrifuge the sample at 6000 revolutions per minute for 5 min and filter the sample through 0.45- μ pore-size membrane filters. Treat the filtrate as a water sample and analyze immediately or split and preserve as required. Retain the solid residue.

The next fraction in the sequence is the moderately reducible phase. Wash the organic and sulfide phase solid residue with 50 ml of distilled water; centrifuge as described earlier; and discard the supernate. Redetermine percent solids on a subsample of the residue. Add 100 ml of a citrate-dithionate solution (16 g sodium citrate + 1.67 g sodium dithionate/100 ml distilled water) and mechanically shake the suspension for 17 hr. Centrifuge the sample at 6000 revolutions per minute for 5 min and filter the supernate through a 0.45- μ pore-size membrane filter. Analyze the filtered sample for moderately reducible constituents and retain the solid residue for further treatment.

The sample for residual phase digestion is obtained by washing the moderately reducible phase residue with 50 ml of distilled water; centrifuging at 6000 revolutions per minute for 5 min; and discarding the supernate. Dry the residue at 105°C and transfer

a 0.5-g dry weight subsample to a teflon beaker. Add 15 ml hydrofluoric acid and 10 ml concentrated nitric acid; cover the beaker; and digest at 175°C. After evaporation to near dryness, add 8 ml fuming nitric acid stepwise in 2-ml increments. Continue evaporation to near dryness. Add 6 N HCl to dissolve the residue, heating if necessary. Quantitatively transfer the solution to a 50-ml volumetric flask and dilute to volume. Analyze the sample immediately or preserve subsamples for specific constituents.

A schematic flow diagram for the fractionation procedure is presented in Figure 2-2. When this procedure is used, a built-in quality control check is to total each of the operationally defined phases and compare to a total digest of the sample. The data should be considered suspect if they differ by more than 5 to 10 percent.

Bulk analysis

A bulk analysis provides a measure of the total concentration of a specific constituent in the sample being analyzed. This is accomplished by subjecting a sample to strong oxidation, acid digestion, or organic solvent extraction. The procedure is similar to that used for the residual phase digestion in the elemental partitioning procedure discussed earlier. Total sediment concentrations can be used to compare different sites and to identify major point sources. However, because of the harshness of the extraction procedure, information on chemical distribution and/or potential environmental impact is lost.

Sample collection. Samples for total analyses may be collected with a dredge or grab sampler or a core sampler. Approximately 1 to 2 l of sediment or fill material should be taken from the proposed project site and placed in plastic jars or containers. If trace organic constituents are to be determined, the sample should be stored in a glass container or a second sample of approximately the same size should be collected and stored separately in glass containers. Samples should be stored at 4°C.

Upon reaching the laboratory, sediment samples may be stored wet, air dried, or frozen. The selection between these preservation techniques should be based primarily on the specific

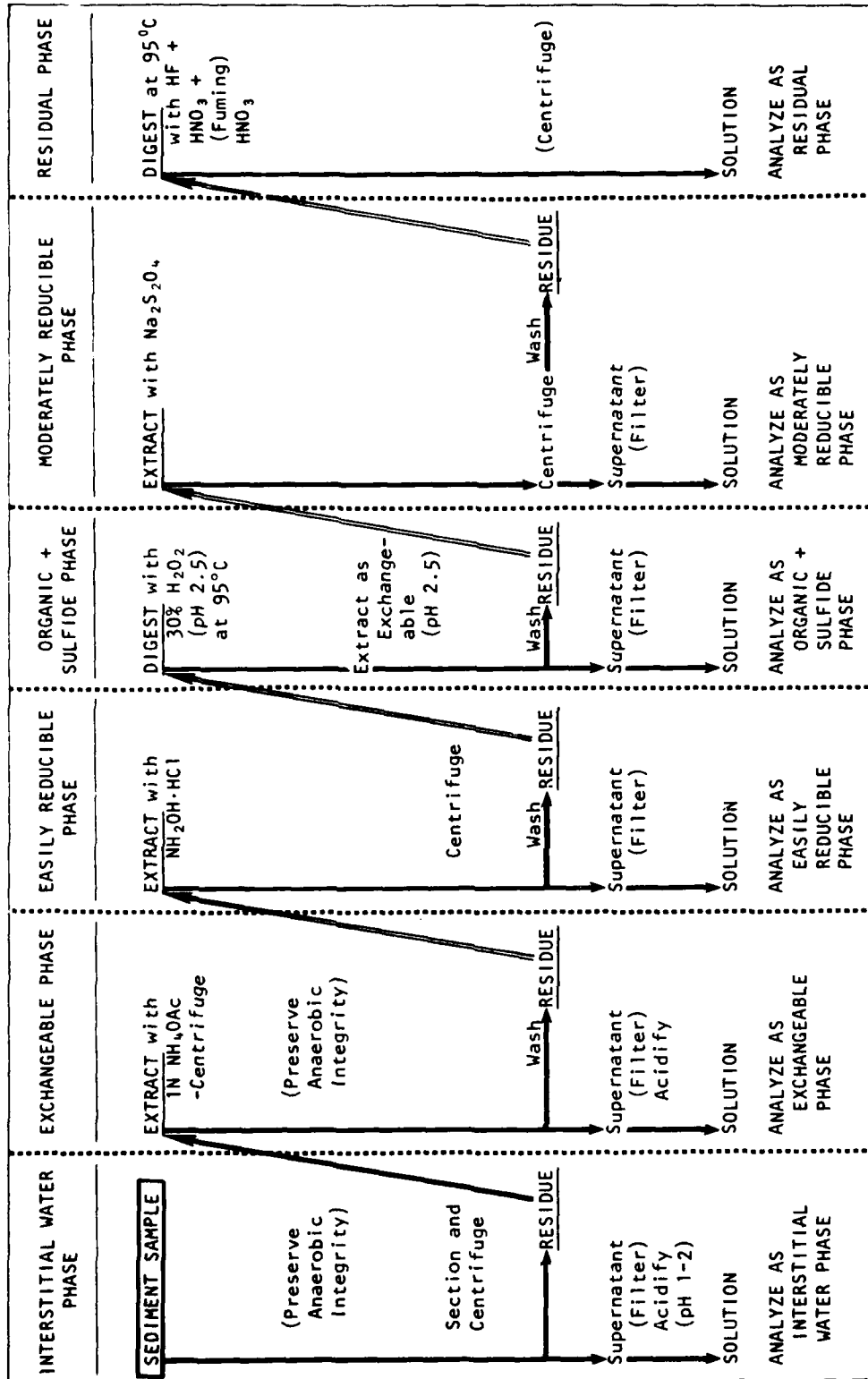

Figure 2-2. Elemental partitioning for sediment characterization

parameter to be determined and, secondarily, on personal choice. Several parameters such as pH, redox, total solids, and volatile solids must be run on wet samples. Other parameters may change due to oxidation (chlorine demand, BOD, COD, SOD, sulfides), volatilization (phenolics, volatile solids), or chemical instability (carbamates, herbicides). Samples to be analyzed for these parameters should be processed as soon as possible using subsamples of the original wet sample. Samples to be analyzed for particle size (dispersed), total organic carbon (TOC), metals (except possibly mercury), chlorinated hydrocarbon pesticides, and PCB's may be stored wet, dried, or frozen.

Apparatus. The specific equipment necessary will vary depending on the chemical constituent(s) to be analyzed in the total sediment digest or the total sediment organic extract. Specific needs and cleanup procedures are discussed with each parameter in Section 3.

Test procedure. The following stepwise procedure is recommended for the processing of sediment or fill material samples to be analyzed for total or bulk content:

- a. Decant any overlying water that may have been collected with the dredge or corer.
- b. Blend the dredge, core, or sectioned core sample.
- c. Transfer an aliquot of the homogenized sample to a tarred weighing dish and weigh. Dry the sample at 105°C to a constant weight. This information will allow calculation of percent solids in the sample and to report subsequent bulk analysis results on a milligram-per-kilogram dry weight basis. The dried sample from the percent solids determination may be subjected to further chemical analysis for those parameters not affected by the drying process.

If volatile solids are to be determined, record the weight of the crucible and the dried sample used in the percent solids determination. Place the sample in an electric muffle furnace and ignite the sample at 600°C for 60 min. Remove the sample from the furnace, allow to cool, and desiccate for 30 min prior to weighing. Report the weight lost on ignition as percent volatile solids.

- d. Transfer a second subsample of the blended sample to a suitable container for pH and oxidation-reduction (redox) potential determinations. The sample size

should be sufficient to allow the electrodes to be inserted to a depth of 4 to 6 cm. Allow sufficient time for the electrode responses to stabilize and record the respective pH and redox values.

- e. Set aside subsamples of the wet, blended sample for the analysis of time-dependent or unstable chemical constituents. Parameters in this category include biological oxygen demand, chemical oxygen demand, sediment oxygen demand, chlorine demand, herbicides and carbamates, phenolics, sulfides, nitrogen, phosphorus, and oil and grease. Thus, as many as 12 subsamples (if all listed analyses are to be performed) will be required. Suggested sample sizes for each aliquot are presented in Figure 2-3. These analyses should be initiated as soon as possible to minimize the effects of sample alteration due to handling and storage.
- f. Set aside separate subsamples for the analysis of particle size, carbon, metals, and chlorinated hydrocarbons. However, because of the increased stability of these constituents (relative to those in Step e, above), the aliquots may be taken from the initial wet, blended sample, or a sample that has been dried or frozen for storage. Required subsample sizes are presented in Figure 2-3.

Individuals performing bulk analysis of sediment samples should be aware of the fact that analytical results may be affected by sample handling and storage procedures. The following special caveats are maintained here because of the importance of this fact and again with the appropriate analytical procedure in Section 3:

- a. It is preferable to determine Eh and pH values in the field as soon as the sample is collected since there is no way to stabilize these parameters. If this is not possible, these parameters should be determined as soon as possible in the laboratory using a wet sample. Sample handling should be kept to a minimum to avoid sample dehydration or sample oxidation.
- b. Percent solids and specific gravity also must be determined on a sample of original moisture content. The sample should be handled in such a manner to minimize water loss and sample dehydration.
- c. Cation exchange capacity can be influenced by sample drying. Therefore, it is recommended that this parameter be determined on original moisture content samples.
- d. Chlorine demand, biological oxygen demand, chemical oxygen demand, and sediment oxygen demand are all

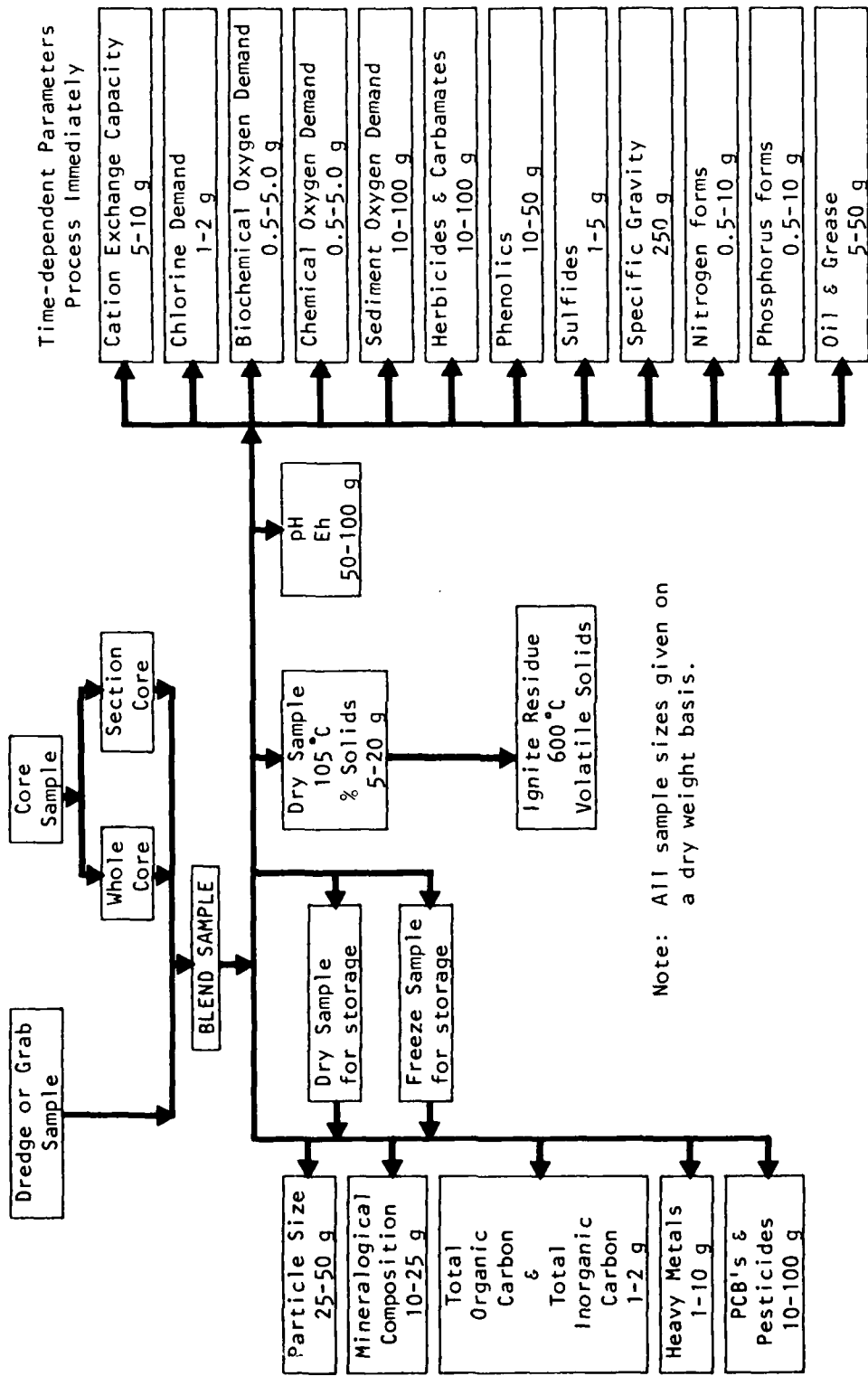

Note: All sample sizes given on a dry weight basis.

Figure 2-3. Sediment sample splitting for bulk analysis

measures of the reducing capacity of the sample being analyzed. Since sediments are frequently reduced and contain elevated concentrations of ferrous iron, manganous manganese, and sulfide that can be oxidized by atmospheric oxygen, these parameters should be run on wet samples.

- e. Herbicides and carbamates are chemically unstable with relatively short half-lives. Immediate extraction of the original sample with methylene chloride reduces the possibility of chemically or biologically catalyzed decomposition and increases herbicide and carbamate stability.
- f. Phenolic compounds may be lost by volatilization during storage. Therefore, samples to be analyzed for phenols should not be dried and storage time should be minimized. If immediate analysis is not possible, storage by freezing may be acceptable. Subsequent sample thawing should be accomplished at low temperature to reduce phenol loss by volatilization.
- g. Sulfides in the sample may be lost by volatilization and oxidation. It is recommended that sample contact with atmospheric oxygen be minimized between sample collection and analysis to reduce this effect. This can best be accomplished by excluding air bubbles from sample containers and minimizing sample storage time.
- h. Some forms of nitrogen that are expected to occur in sediments (nitrites) are unstable in the presence of oxygen and can be lost on sample drying. In addition, sample composition may be altered by the uptake or loss of volatile ammonia. Therefore, sample processing should begin as soon as possible using a sample of original moisture content.
- i. The distribution of phosphorus forms may be altered by changes in other sample constituents. For example, the oxidation of iron in a sample may precipitate soluble phosphate. Therefore, if soluble phosphate is to be determined, wet samples should be processed as soon as possible. If total phosphate is the only parameter of concern, analysis can be conducted on a wet, dried, or frozen sample.
- j. The oil and grease content of samples may be reduced due to volatilization. Consequently, sample drying prior to analysis is not recommended.
- k. The selection of a storage technique for samples to be analyzed for particle size depends on the method of analysis. If apparent particle size is to be run, a wet sample should be used. However, if dispersed particle size is to be run, a wet, dried, or frozen sample may be used.

- l. Most of the heavy metals are stable and samples scheduled for analysis can be stored in a wet, dried, or frozen state. The selection of a storage method can affect the distribution of a metal among various forms, but the total concentration should be unaffected. Two possible exceptions are mercury and selenium, which can be lost by volatilization. This particularly is true if the samples are dried above 60°C.
- m. Chlorinated hydrocarbon pesticides and PCB's are stable and probably unaffected by the method of sample storage. Improved stability can be achieved by immediate extraction of the original sample with an organic solvent and is suggested, but not essential.
- n. The analysis of a sediment or fill material sample for specific constituents will require a sample digestion or sample extraction technique. Since the selection of a digestion solution or solvent is dependent on the analysis to be performed, this information is presented with the specific analytical techniques.

Summary

Dredged material may be subjected to several types of testing. This section has provided guidance for conducting elutriate testing, elemental partitioning, and bulk analysis of sedimentary samples. Since each of these procedures measures a different property of the sample, different storage requirements are required for samples to be subjected to each testing procedure. Therefore, this section has also provided detailed guidance for the handling of sedimentary samples from the time of collection until the time of analysis.

References

1. Environmental Protection Agency. "Draft Interim Analytical Methods Manual for the Ocean Disposal Permit Program." EPA; Washington, D.C. (January 1974).
2. Environmental Effects Laboratory. "Ecological Evaluation of Proposed Discharge of Dredged or Fill Material into Navigable Waters. Interim Guidance for Implementation of Section 404(b)(1) of Public Law 92-500 (Federal Water Pollution Control Act Amendments of 1972)." Miscellaneous Paper D-76-17. U. S. Army Engineer Waterways Experiment Station, CE; Vicksburg, Mississippi (1976).
3. Environmental Protection Agency. "NPDES Compliance Sampling Manual." Enforcement Division, Office of Water Enforcement, Compliance Branch, EPA; Washington, D.C. 139 p. (1977).
4. American Public Health Association. Standard Methods for the Examination of Water and Wastewater Including Bottom Sediments and Sludges. 14th Edition. American Public Health Association, New York, New York. 1193 p. (1975).
5. Sly, P. G. "Bottom Sediment Sampling." Proc. 12th Conf. Gr. Lakes Res. pp. 883-898 (1969).
6. Howmiller, R. P. "A Comparison of the Effectiveness of Ekman and Ponar Grabs." Trans. Amer. Fish. Soc. 100:560-564 (1971).
7. Wigley, R. L. "Comparative Efficiencies of Van Veen and Smith-McIntyre Grab Samplers as Revealed by Motion Pictures." Ecology 48:168-169 (1967).
8. Hudson, P. L. "Quantitative Sampling with Three Benthic Dredges." Trans. Amer. Fish. Soc. 99:603-607 (1970).
9. Christie, N. D. "Relationship Between Sediment Texture, Species Richness, and Volume of Sediment Sampled by a Grab." Marine Biology 30:89-96 (1975).
10. Brannon, J. M., Plumb Jr., R. H., and Smith, I. "Long Term Release of Contaminants from Dredged Material." Technical Report D-78-49. U. S. Army Engineer Waterways Experiment Station, CE, Vicksburg, Mississippi. 66 p. (1978).
11. Brannon, J. M., Engler, R. M., Rose, J. R., Hunt, P. G., and Smith, I. "Selective Analytical Partitioning of Sediments to Evaluate Potential Mobility of Chemical Constituents During Dredging and Disposal Operations." Technical Report D-76-7. U. S. Army Engineer Waterways Experiment Station, CE; Vicksburg, Mississippi. 90 p. (1976).
12. Jenne, E. A., and Luoma, S. N. "Forms of Trace Elements in Soils, Sediments, and Associated Waters: An Overview of Their Determination and Biological Availability." U. S. Geological Survey; Menlo Park, California. Presentation at Biological Implications

- of Metals in the Environment. 15th Life Sciences Symposium; Hanford, Connecticut. 74 p. (September 29 - October 1, 1975).
13. Chen, K. Y., Gupta, S. K., Sycip, A. Z., Lu, J. C. S., Knezevic, M., and Choi, W. W. "Research Study on the Effect of Dispersion Settling, and Resedimentation on Migration of Chemical Constituents During Open Water Disposal of Dredged Materials." Contract Report D-76-1. U. S. Army Engineer Waterways Experiment Station, CE; Vicksburg, Mississippi. 221 p. (1976).
 14. Lee, G. F. "Chemical Aspects of Bioassay Techniques for Establishing Water Quality Criteria." Water Res. 7:1525-1546 (1973).
 15. Environmental Protection Agency. "Methods for Chemical Analysis of Water and Wastes." National Environmental Research Center, EPA; Cincinnati, Ohio. EPA-625/6-74-003. 298 p. (1974).
 16. Sherma, J. "Manual of Analytical Quality Control for Pesticides and Related Compounds in Human and Environmental Samples." Contract 68-02-1727. EPA Health Effects Research Laboratory; Research Triangle Park, North Carolina. EPA-600/1-76-017. Unnumbered (1976).
 17. Environmental Protection Agency. "Handbook for Analytical Quality Control in Water and Wastewater Laboratories." Environmental Monitoring and Support Laboratory, Environmental Research Center; Cincinnati, Ohio. Draft Report (1978).
 18. Delfino, J. J. "Quality Assurance in Water and Wastewater Analysis Laboratories." Water and Sewage Works 124(7):79-84 (1977).
 19. Anon. "Federal Environmental Monitoring: Will the Bubble Burst?" QA Report. Environmental Science and Technology 12:1264-1269 (1978).
 20. Keeley, J. W., and Engler, R. M. "Discussion of Regulatory Criteria for Ocean Disposal of Dredged Materials: Elutriate Test Rationale and Implementation Guidelines." Miscellaneous Paper D-74-14. U. S. Army Engineer Waterways Experiment Station, CE; Vicksburg, Mississippi (1974).
 21. Lee, G. F., Pivoni, M. D., Lopez, J. M., Mariani, G. M., Richardson, J. S., Homer, D. H., and Saleh, F. "Research Study for the Development of Dredged Material Disposal Criteria." Technical Report D-75-14. U. S. Army Engineer Waterways Experiment Station, CE; Vicksburg, Mississippi (1975).
 22. Plumb, R. H., Jr. "A Bioassay Dilution Technique to Assess the Significance of Dredged Material Disposal." Miscellaneous Paper D-76-6. U. S. Army Engineer Waterways Experiment Station, CE; Vicksburg, Mississippi. 16 p. (1976).
 23. Neff, J. W., Foster, R. S., and Slowey, J. F. "Availability of Sediment-Adsorbed Heavy Metals to Benthos with Particular Emphasis on Deposit Feeding Infauna." Technical Report D-78-42. U. S. Army Engineer Waterways Experiment Station, CE; Vicksburg, Mississippi (1978).

Army Engineer Waterways Experiment Station, CE; Vicksburg,
Mississippi. 286 p. (1978).

24. Lee, G. F. and Plumb, R. H. Jr. "Literature Review on Research
Study for the Development of Dredged Material Disposal Criteria."
Contract Report D-74-1. U. S. Army Engineer Waterways Experiment
Station, CE; Vicksburg, Mississippi. 145 p. (1974).

SECTION 3: ANALYTICAL METHODS

Introduction

This section presents analytical procedures for selected parameters to be used for the analysis of water, sediments, and sediment fractions. The procedures can also be used for analysis of biological tissue with paper sample preparation. The two major criteria used to select the procedures were:

- a. The procedures have been shown to be precise and accurate.
- b. The required equipment is generally available.

The criterion for a precise and accurate procedure was that it be considered an acceptable test procedure based on guidelines established in Section 304(g) of PL 92-500 or, alternately, the procedure be accepted as standard in analytical compendiums such as Standard Methods or an ASTM Water Manual based on critical review and performance evaluation. A list of acceptable methods and specific references is provided in Table 3-1. This list was abstracted from the Environmental Protection Agency (EPA) list of approved procedures that has been previously published in the Federal Register.¹

The criterion for equipment availability is more subjective and based largely on the capabilities of the intended principal users. The reason for considering this factor is that smaller laboratories are usually involved in Section 404 permit evaluations and these laboratories are not generally equipped with the more sophisticated equipment found in larger research laboratories. Thus, the listed procedures require colorimeters, atomic absorption spectrophotometers, and gas chromatographs rather than inductively coupled plasma arc techniques, neutron activation analysis, or gas chromatograph/mass spectrophotometers. The latter equipment can certainly be used but their distribution is not considered sufficiently widespread to warrant inclusion in a general manual at this time.

Each analytical procedure presented in the remainder of

this section is accompanied with a flow diagram similar to Figure 3-1 and these diagrams have several uses. First, there are three options for storing sediment samples: wet, dry, or frozen. When there is reason to believe that one of these methods is unsuitable, such as drying sediments to be analyzed for oxygen demand, this portion of the flow diagram has been deleted. Second, the diagram reinforces the fact that only wet sediments should be used for the elutriate test, sediment fractionation studies, and bioassays. Third, information has been tabulated on sample containers, preservatives, storage time, digestion or extraction solutions, and required sample size. The user is cautioned that storage times and preservatives for sediments are not known with certainty. Therefore, wet sediments should be processed as soon as possible and preferably within 1 week. Also, while drying and freezing may allow extended storage of sediment samples to be analyzed for some chemical contaminants, the upper limit for such storage is not known and the general usefulness of the samples is reduced. (They should not be used in bioassays or fractionation studies or analyzed for labile parameters such as oxygen demand, sulfide, and some organic compounds.) Finally, a uniform sample designation code has been established throughout the manual as indicated in Figure 3-1. Thus, W1 is a total water sample; S1A is an elutriate sample; and S2 is an air-dried sediment sample. This code is used in discussing the analytical preparation of the samples.

Procedures are also provided for the digestion or extraction of sediment samples. The user is cautioned that efficiency of digestion or extraction solutions is poorly known in a wide range of sediment types. This factor was considered in selecting digestion procedures. For example, hydrofluoric acid digestion is commonly considered as the most effective digestion procedure for metals. However, the use of this acid requires appropriate hoods and safety equipment. Since this equipment was not considered routinely available in the laboratories of the intended users of this manual, a nitric acid-hydrochloric acid digestion that has been shown to be effective for metals was presented for use. While the nitric acid-hydrochloric acid treatment may produce

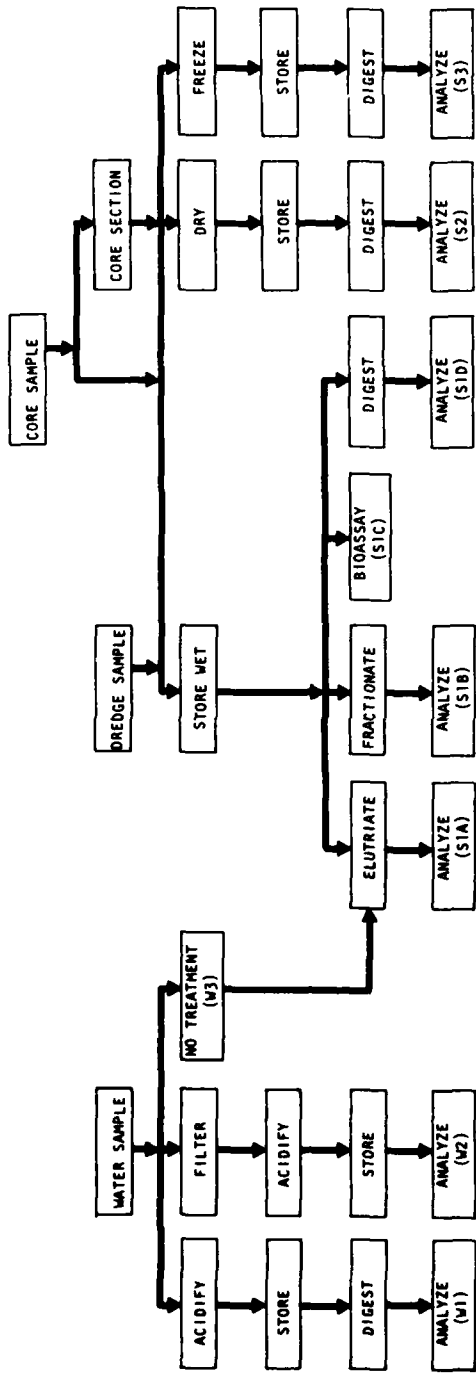

SAMPLE DESIGNATION	W1	W2	W3	S1A	S1B	S1C	S1D	S2	S3
	Total Water Conc.	Soluble Water Conc.	Used in Elutriate Conc.	Mobile Conc.	Chemical Distribution	Bioavail-ability	Total Sediment Conc.	Total Sediment Conc.	Total Sediment Conc.
PURPOSE									
CONTAINER									
SAMPLE TREATMENT									
PRESERVATIVE									
STORAGE TIME									
DIGESTION SOLUTION									
SAMPLE VOLUME OR WEIGHT									

Figure 3-1. Schematic of generalized sample handling procedure

lower analytical results than hydrofluoric acid treatment for some samples, the difference is not considered significant in terms of the present inability to relate bulk analysis results with environmental effects. Thus, the procedure is considered suitable for routine use, safety, and reproducibility. Where there is a lack of agreement on the best sample preparation method, several digestion solutions or solvents are presented.

One final point should be mentioned. The methodology provides for the preparation of three water samples (total water, W-1; filtered water, W-2; and elutriate, S1A) and as many as five sediment samples (fractionation, S1B; bioassay, S1C; wet sediments, S1D; dried sediments, S2; and frozen sediments, S3). It is not necessary to analyze each of these fractions for all samples collected. The fractions are listed only to provide appropriate guidance on their preparation after it has been decided to run them. In addition, the method section provides guidance for 44 parameters. It is not necessary or recommended that all possible analyses be run on all samples. This manual is simply presenting recommended methodologies that should be followed once it has been determined that a specific analysis is required. Also, failure to list a specific analysis does not mean that it should not be considered for use where appropriate. However, other references will have to be used for detailed guidance.

References

1. Environmental Protection Agency. "Water Programs. Guidelines Establishing Test Procedures for the Analysis of Pollutants." Federal Register. p. 52780-52786 (1 December 1976).

Table 3-1

Acceptable Test Procedures*

Parameter and Units	Method**	References (Page Nos.)				
		EPA Methods ²	14th Ed. Standard Methods ³	Pt. 31 1975 ASTM ⁴	USGS Methods ⁵	Other Approved Methods [†]
Ammonia (as N), mg/l	Manual distillation ⁷ (at pH 9.5) followed by nesslerization, titration, electrode, automated phenolate	159 165 168	410 412 616	237	116	6(614)
	Winkler (azide modifi- cation) or electrode method		543		7(50) ⁸	9(17)
	Dichromate reflux	20	550	472	124	6(610)
Chlorinated organic compounds (except pesticides), mg/l	Gas chromatography ¹¹					
Hydrogen ion (pH) units	Electrometric measure- ment	239	460	178	129	6(606)

(Continued)

(Sheet 1 of 14)

* Information in this table abstracted from the Environmental Protection Agency, 1976 (Table Ref 1).
 † Number in parentheses refers to the page number of the indicated reference on Page 12, 13, and 14 of this table.

** Raised numbers refer to the corresponding footnote on Page 12, 13, and 14 of this table.

Table 3-1 (Continued)

Parameters and Units	Method**	References (Page Nos.)					
		EPA Methods ²	14th Ed. Standard Methods ³	Ft. 31 1975 ASTM ⁴	USGS Methods ⁵	Other Approved Methodst	
Kjeldahl nitrogen (as N), mg/l	Digestion and distillation followed by nesslerization, titration, or electrode; automated digestion, automated phenolate	175 165 182	437		122	6(612)	
Arsenic--total, mg/l	Digestion followed by silver diethyl dithiocarbamate or atomic absorption ^{13,15}	95	285 283 159	-- -- --	-- (31) ¹⁰ (37) ¹⁰		
Arsenic--dissolved	0.45- μ filtration ¹⁴ followed by referenced method for total arsenic	--	--	--	--		
Cadmium--dissolved, mg/l	Digestion ¹² followed by atomic absorption ^{13,15}	101	148 182	345	62	(619) ⁶ (37) ⁹	
Cadmium--dissolved, mg/l	0.45- μ filtration ¹⁴ followed by referenced method for total cadmium	--	--	--	--	--	
Calcium--total, mg/l	Digestion ¹² followed by atomic absorption ^{13,15}	103	148 189	345	66		

(Continued)

(Sheet 2 of 14)

+ Number in parentheses refers to the page number of the indicated reference on page 12, 13, and 14 of this table.

Table 3-1 (Continued)

Parameters and Units	Method**	References (Page Nos.)				
		EPA Methods ²	14th Ed. Standard Methods ³	Pt. 31 1975 ASTM ⁴	USGS Methods ⁵	Other Approved Methodst
Calcium--dissolved, mg/l	0.45- μ filtration ¹⁴ fol- lowed by referenced method for total calcium					
Chromium VI, mg/l	Extraction and atomic absorption; colori- metric (Diphenylcarbazide)	89 105	192		76 75	
Chromium VI-- dissolved, mg/l	0.45- μ filtration ¹⁴ followed by referenced method for chromium VI					
Chromium--total, mg/l	Digestion ¹² followed by atomic absorption ¹³ or by colorimetric (diphenylcarbazide)	105	148 192	345 286	78 77	6(619)

(Continued)

(Sheet 3 of 14)

† Number in parentheses refers to the page number of the indicated reference on page 12, 13, and 14 of this table.

Table 3-1 (Continued)

Parameters and Units	Method**	References (Page Nos.)				
		EPA Methods ²	14th Ed. Standard Methods ³	Pt. 31 1975 ASTM ⁴	USGS Methods ⁵	Other Approved Methods [†]
Chromium--dissolved, mg/l	0.45- μ filtration ¹⁴ followed by referenced method for total chromium					
Copper--total, mg/l	Digestion ¹² followed by atomic absorption ¹³ or by colorimetric (neocuproine)	108	148 196	345 293	83	6(619) 9(37)
Copper--dissolved, mg/l	0.45- μ filtration ¹⁴ followed by referenced method for total copper					
Iron--total, mg/l	Digestion ¹² followed by atomic absorption ¹³ or by colorimetric (phenanthroline)	110	148 208	345 326	102	6(619)
Iron--dissolved, mg/l	0.45- μ filtration ¹⁴ followed by referenced method for total iron					
Lead--total, mg/l	Digestion ¹² followed by atomic absorption ¹³ or by colorimetric (dithizone)	112	148 215	345	105	6(619)

(Continued)

(Sheet 4 of 14)

[†] Number in parentheses refers to the page number of the indicated reference on Page 12, 13, and 14 of this table.

Table 3-1 (Continued)

Parameters and Units	Method**	References (Page Nos.)				
		EPA Methods ²	14th Ed. Standard Methods ³	Pt. 31 1975 ASTM ⁴	USGS Methods ⁵	Other Approved Methods [†]
Lead--dissolved, mg/l	0.45- μ filtration ¹⁴ followed by referenced method for total lead.					
Magnesium--total, mg/l	Digestion ¹² followed by atomic absorption; or gravimetric	114	148 221	345	100	6(619)
Magnesium--dissolved, mg/l	0.45- μ filtration ¹⁴ followed by referenced method for total magnesium					
Manganese--total, mg/l	Digestion ¹² followed by atomic absorption ¹³ or by colorimetric (persulfate or periodate)	116	148 225 227	345	111	6(619)
Manganese--dissolved, mg/l	0.45- μ filtration ¹⁴ followed by referenced method for total manganese					

(Continued)

(Sheet 5 of 14)

† Number in parentheses refers to the page number of the indicated reference on Page 12, 13, and 14 of this table.

Table 3-1 (Continued)

Parameters and Units	Method**	References (Page Nos.)				
		EPA Methods ²	14th Ed. Standard Methods ³	Pt. 31 1975 ASPM ⁴	USGS Methods ⁵	Other Approved Methods ⁶
Mercury--total, mg/l	Flameless atomic absorption	118	156	333	11(51) ¹⁰	
Mercury--dissolved, mg/l	0.45- μ filtration ¹⁴ followed by referenced method for total mercury					
Molybdenum--total, mg/l	Digestion ¹² followed by atomic absorption ¹³	139		350		
Molybdenum--dissolved, mg/l	0.45- μ filtration ¹⁴ followed by referenced method for total molybdenum					
Nickel--total, mg/l	Digestion ¹² followed by atomic absorption ¹³ or by colorimetric (heptoxime)	141	148	345	115	
Nickel--dissolved, mg/l	0.45- μ filtration ¹⁶ followed by referenced method for total nickel		232			

(Continued)

(Sheet 6 of 11)

* Number in parentheses refers to the page number of the indicated reference on Page 10, 13, and 11 of this table.

Table 3-1 (Continued)

Parameters and Units	Method**	References (Page Nos.)				
		EPA Methods ²	14th Ed. Standard Methods ³	Pt. 31 1975 ASTM ⁴	USGS Methods ⁵	Other Approved Methods ⁶
Potassium--total, mg/l	Digestion ¹² followed by atomic absorption, colorimetric (cobaltinitrite), or by flame photometric	143	235 234	403	134	6(620)
Potassium--dissolved, mg/l	0.45- μ filtration ¹⁴ followed by referenced method for total potassium					
Selenium--total, mg/l	Digestion ¹² followed by atomic absorption ^{15,16}	145	159			
Selenium--dissolved, mg/l	0.45- μ filtration ¹⁴ followed by referenced method for total selenium					
Sodium--total, mg/l	Digestion ¹² followed by atomic absorption or by flame photometric	147	250	403	143	6(621)

(Continued)

(Sheet 7 of 14)

+ Number in parentheses refers to the page number of the indicated reference on Page 10, 13, and 14 of this table.

Table 3-1 (Continued)

Parameter and Units	Method**	Reference (Page Nos.)				
		EPA Methods ²	14th Ed. Standard Methods ³	Pt. 31 1975 ASTM ⁴	USCS Methods ⁵	Other Approved Methods ⁺
Sodium--dissolved, mg/l	0.45- μ filtration ¹⁴ followed by referenced method for total sodium	155	148 265	345	159	6(619) 9(37)
Zinc--total, mg/l	Digestion ¹² followed by atomic absorption ¹³ or by colorimetric (dithizone)					
Zinc-dissolved, mg/l	0.45- μ filtration ¹⁴ followed by referenced method for total zinc					
Nitrate (as N), mg/l	Cadmium reduction;	201	423	358	119	6(614)
	brucine sulfate;	197	427			9(28)
	automated cadmium or hydrazine reduction ¹⁷	207	620			
Nitrite (as N), mg/l	Manual or automated colorimetric (diazotization)	215	434		121	

(Continued)

(Sheet 8 of 11)

+ Number in parentheses refers to the page number of the indicated reference on Page 12, 13, and 14 of this table.

Table 3-1 (Continued)

Parameters and Units	Method**	References (Page Nos.)				
		EPA Methods ²	14th Ed. Standard Methods ³	Pt. 31 1975 ASTM ⁴	USGS Methods ⁵	Other Approved Methods ⁺
Oil and grease, mg/l	Liquid-liquid extraction with trichlorotrifluoroethane-gravimetric	229	515			
Organic carbon (as TOC), mg/l	Combustion infrared method ¹⁸	236	532	467	17(4)	
Organic nitrogen (as N), mg/l	Kjeldahl nitrogen minus ammonia nitrogen	175 179	437		122	6(612) 6(614)
Ortho-phosphate (as P), mg/l	Manual or automated ascorbic acid reduction	249 256	481 624	384	131	6(621)
Pentachlorophenol, mg/l	Gas chromatography ¹¹					
Pesticides, mg/l	Gas chromatography ¹¹		555	529	19(24) ⁺	
Phenols, mg/l	Colorimetric (4AAP)	241	574	545		

(Continued)

(Sheet 9 of 14)

* Number in parentheses refers to the page number of the indicated reference on Page 12, 13, and 14 of this table.

Table 3-1 (Continued)

Parameters and Units	Method**	References (Page Nos.)			
		EPA Methods ²	14th Ed. Standard Methods ³	Pt. 31 1975 ASTM ⁴	Other Approved Methods ⁵
Phosphorus--total (as P), mg/l	Persulfate digestion followed by manual or automated ascorbic acid reduction	249 256	176 181 624	394	133 6(621)
Solids--total, mg/l	Gravimetric, 103° to 105°C	270	91		
Solids--total dissolved (filterable), mg/l	Glass fiber filtration, 180°C	266	92		
Solids--total sus- pended (non- filterable), mg/l	Glass fiber filtration, 103° to 105°C	268	94		
Solids--settleable, ml/l or mg/l	Volumetric or gravi- metric		95		
Solids--total volatile, mg/l	Gravimetric, 550°C	272	95		
Specific conductance, µmhos/cm at 25°C	Wheatstone bridge conductimetry	275	71	120	148 6(606)

(Continued)

(Sheet 10 of 14)

* Number in parentheses refers to the page number of the indicated reference on Page 12, 13, and 14 of this table.

Table 3-1 (Continued)

Parameters and Units	Method**	References (Page Nos.)				
		EPA Methods ²	14th Ed. Standard Methods ³	Pt. 31 1975 ASTM ⁴	USGS Methods ⁵	Other Approved Methods ⁺
Sulfide (as S), mg/l	Titrimetric--iodine for levels greater than 1 mg/l; methylene blue photometric	284	505 503		154	
Temperature, °C	Calibrated glass or electrometric thermometer	286	125		20(31) ⁺	

(Continued)

(Sheet 11 of 14)

+ Number in parentheses refers to the page number of the indicated reference on Page 12, 13, and 14 of this table.

Table 3-1 (Continued)

References

1. Environmental Protection Agency. "Water Programs Guidelines Establishing Test Procedures for the Analysis of Pollutants." Federal Register, 52780-52786 (1 December 1976).
2. Environmental Protection Agency. "Methods for Chemical Analysis of Water and Wastes." Environmental Monitoring and Support Laboratory, Office of Research and Development, EPA; Cincinnati, Ohio. 298 p. (1974).
3. American Public Health Association. Standard Methods for the Examination of Water and Wastewater Including Bottom Sediments and Sludges. 14th Edition. American Public Health Association, New York, New York. 1193 p. (1975).
4. American Society for Testing and Materials. Annual Book of Standards, Part 31, Water. American Society for Testing and Materials, 1916 Race Street, Philadelphia, Pennsylvania (1976).
5. Brown, E., Skougstad, M. W., and Fishman, M. J. "Methods for Collection and Analyses of Water Samples for Dissolved Minerals and Gases." U. S. Geological Survey Techniques of Water Resources Inventory, Book 5, Chapter A1. Reston, Virginia (1970). All page citations refer to this reference unless otherwise noted.
6. EPA comparable method may be found on the indicated page of "Official Methods of Analysis of the Association of Official Analytical Chemists," methods manual, 12th ed. (1975).
7. Manual distillation is not required if comparability data on representative effluent samples are on file to show that this preliminary distillation step is not necessary; however, manual distillation will be required to resolve any controversies.
8. Slack, K. V. et al. "Methods for Collection and Analysis of Aquatic Biological and Micro-biological Samples." U. S. Geological Survey Techniques of Water Resources Inventory, Book 5, Chapter A4. Reston, Virginia (1973).
9. American National Standard on Photographic Processing Effluents, April 2, 1975. Available from ANSI, 1430 Broadway; New York, New York 10018.
10. Fishman, M. J., and Brown, E. "Selected Methods of the U. S. Geological Survey for Analysis

(Continued)

(Sheet 12 of 14)

Table 3-1 (Continued)

References (Continued)

- of Wastewaters". Open-file report 76-177 (1976).
11. Procedures for pentachlorophenol, chlorinated organic compounds, and pesticides can be obtained from the Environmental Monitoring and Support Laboratory, EPA; Cincinnati, Ohio 45268.
 12. For the determination of total metals, the sample is not filtered before processing. Because vigorous digestion procedures may result in a loss of certain metals through precipitation, a less vigorous treatment is recommended as given on p. 83 (4.1.4) of "Methods for Chemical Analysis of Water and Wastes" (1974). In those instances where a more vigorous digestion is desired, the procedure on p. 82 (4.1.3) should be followed. For the measurement of the noble metal series (gold, iridium, osmium, palladium, platinum, rhodium, and ruthenium), an aqua regia digestion is to be substituted as follows: Transfer a representative aliquot of the well-mixed sample to a Griffin beaker and add 3 ml of concentrated redistilled HNO_3 . Place the beaker on a steam bath and evaporate to dryness. Cool the beaker and cautiously add a 5-ml portion of aqua regia. (Aqua regia is prepared immediately before use by carefully adding three volumes of concentrated HCl to one volume of concentrated HNO_3 .) Cover the beaker with a watch glass and return to the steam bath. Continue heating the covered beaker for 50 min. Remove cover and evaporate to dryness. Cool and take up the residue in a small quantity of 1:1 HCl . Wash down the beaker walls and watch glass with distilled water and filter the sample to remove silicates and other insoluble material that could clog the atomizer. Adjust the volume to some predetermined value based on the expected metal concentration. The same is now ready for analysis.
 13. As the various furnace devices (flameless atomic absorption spectrophotometer) are essentially atomic absorption techniques, they are considered to be approved test methods. Methods of standard addition are to be followed as noted on p. 78 of "Methods for Chemical Analysis of Water and Wastes" (1974).
 14. Dissolved metals are defined as those constituents that will pass through a 0.45- μ membrane filter. A Prefiltration is permissible to free the sample from larger suspended solids. Filter the sample as soon as practical after collection using the first 50 to 100 ml to rinse

(Continued)

(Sheet 13 of 14)

Table 3-1 (Concluded)

References (Continued)

the flask and collect the required volume of filtrate. Acidify the filtrate with 1:1 redistilled HNO₃ to a pH of 2. Normally, 3 ml of (1:1) acid per liter should be sufficient to preserve the samples.

15. See "Atomic Absorption Newsletter," vol. 13, 75 (1974). Available from Perkin-Elmer Corporation, Main Avenue, Norwalk, Connecticut 06852.
16. Method available from Environmental Monitoring and Support Laboratory, EPA; Cincinnati, Ohio 45268.
17. An automated hydrazine reduction method is available from the Environmental Monitoring and Support Laboratory, EPA, Cincinnati, Ohio 45268.
18. A number of such systems manufactured by various companies are considered to be comparable in their performance. In addition, another technique, based on combustion-methane detection, is also acceptable.
19. Goerlitz, D., and Brown, E. "Methods for Analysis of Organic Substances in Water." U. S. Geological Survey Techniques of Water Resources Inventory, Book 5, Chapter A3 (1972).
20. Stevens, H. H., Ficke, J. F., and Smoot, G. F. "Water Temperature--Influent Factors, Field Measurement and Data Presentation". U. S. Geological Survey Techniques of Water Resources Inventory, Book 1 (1975).

PHYSICAL ANALYSIS

Cation Exchange Capacity

Particle Size

pH

Oxidation Reduction Potential

Solids

Total

Volatile

Specific Gravity

CATION EXCHANGE CAPACITY

The cation exchange capacity (CEC) of a sediment is a measure of the reversibly bound cations in the sample, that is, a measure of those cations held on the surface, within the crystalline matrix of some minerals.^{1*} These cations may potentially be released to the water column under appropriate conditions.

The procedure consists of equilibrating a sediment sample with a highly soluble salt solution.¹⁻³ The theory behind the procedure is that the high concentration of a soluble cation will replace the sorbed or bound cations associated with the sediment. The replaced cations can then be determined individually in the leachate or the sediment sample can be washed and reequilibrated with a second soluble salt. The second leachate is then analyzed for total cation exchange capacity. The standard leachate that is most often used is 1 N ammonium acetate. Principal advantages of this approach are the pH buffering capacity of ammonium acetate solutions and the relative ease of the ammonia determination. However, ammonium acetate may yield low results with (a) samples containing 1:1 type clay minerals such as kaolin or halloysite, or (b) highly calcareous sediments due to the dissolution of calcium carbonate.¹

The exchange capacity of a sample is influenced by the clay content of the sample, the type of clay, the organic matter content, the pH of the displacing solution, the nature and concentration of the displacing cation, and the sediment-to-solution ratio. Since many of these factors are operationally defined, the CEC of the sample should be considered operationally defined. Most techniques will only vary the magnitude of the CEC of a sample and not the relative order of a number of samples.¹ Therefore, care should be taken to standardize as many variables as possible (ammonia concentration, pH, solid-liquid ratio, and time of contact) to ensure uniformity and comparability of results.

* References for this procedure are on Page 3-27.

Sample Handling and Storage

Samples may be collected with any convenient collection device and stored in either glass or plastic containers. Field moist samples should be used for the CEC determination as the process of drying has been shown to alter the CEC.¹⁷⁴ At this time, the storage time limits are not known. Since sample oxidation may indirectly affect CEC, it is recommended that samples be processed as soon as practical. Samples may be frozen, if necessary, but should be thawed quickly prior to analysis, and portions of samples indicating oxidation should be discarded. This information is summarized in Figure 3-2.

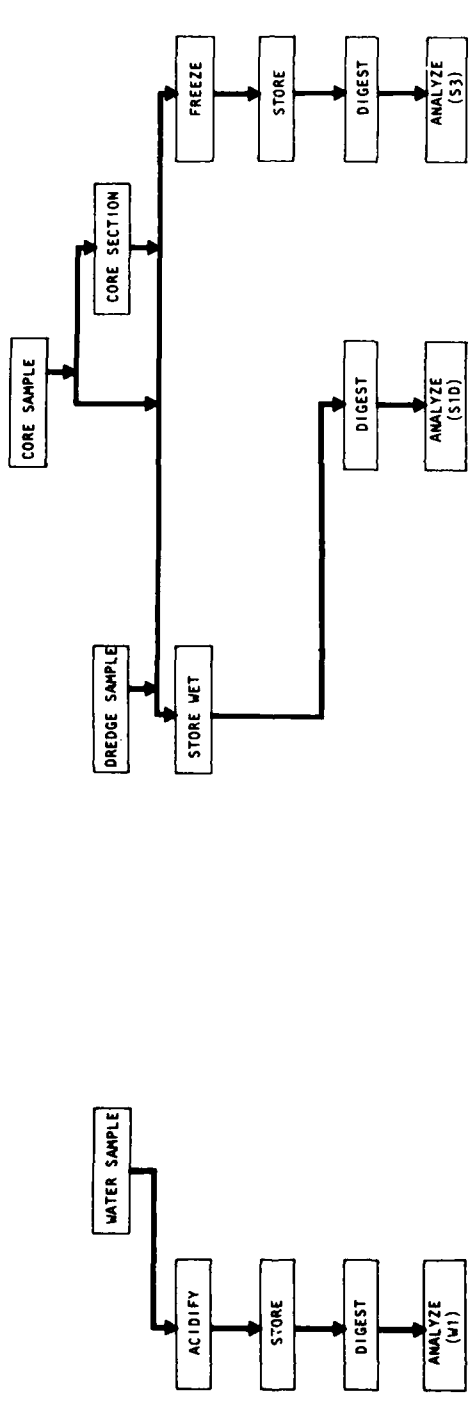

SAMPLE DESIGNATION	W1	W2	W3	S1A	S1B	S1C	S1D	S2	S3
PURPOSE	Total Water Conc.						Total Sediment Conc.		Total Sediment Conc.
CONTAINER	G,P						G,P		G,P
SAMPLE TREATMENT	None						None		Freeze
PRESERVATIVE	-						4 °C		None
STORAGE TIME	-						<1w		-
DIGESTION SOLUTION	NH ₄ OAC						NH ₄ OAC		NH ₄ OAC
SAMPLE VOLUME OR WEIGHT	1 L						5-25 g		5-25 g

Figure 3-2. Handling and storage procedures for cation exchange capacity samples

Procedures for Sediment Samples (S1D, S3)

Method 1: Agitation, Filtration

Apparatus

Wrist-action shaker

Filtration apparatus

Erlenmeyer flasks

Reagents

1 N ammonium acetate: dissolve 77 g ammonium acetate in distilled water and dilute to 1 l.

80 percent ethanol: mix 80 ml ethanol with 200 ml distilled water.

10 percent sodium chloride: dissolve 100 g sodium chloride in distilled water and dilute to 1 l.

Procedure

Blend sediment sample and pass through a 100-mesh stainless steel screen to remove coarse particles such as wood and shellfish fragments. As quickly as possible (to minimize sample oxidation effects), weigh out 5- to 25-g subsamples. The smaller size is suitable for high silt-clay content sediments and the larger size is suitable for sandy sediments.

NOTE: If marine or brackish sediments are used, wash the sediments with distilled water until there is no trace of chloride. Proceed as indicated below.

Rapidly transfer the sample to a 250- to 300-ml Erlenmeyer flask and immediately add 100 ml 1 N ammonium acetate. Seal the samples with parafilm and place on a wrist-action shaker. Agitate the samples for 30 min.

While the samples are on the shaker, weigh out a separate portion of the original sample for a percent solids determination. Dry the sample at 105°C, cool in a desiccator, and reweigh (Page 3-58).

After 30 min, filter the ammonium acetate-sediment suspensions through a Whatman No. 40 filter or equivalent. Wash the retained solids with an additional 400 ml 1 N ammonium acetate. Add the rinsing to the filtrate and retain for the determination of exchangeable metals if desired.

Wash the solids with 25 ml 80 percent ethanol and discard the filtrate. Repeat the washing procedure with four additional 25-ml aliquots of ethanol to ensure complete removal of any excess ammonium acetate.

Leach the solids on the filter with 10 percent sodium chloride solution until 50 ml of leachate has been collected. Filter the sample through a 0.45- μ pore-size membrane filter and analyze the leachate for ammonia using either one of the procedures presented elsewhere or an ammonia electrode.

If it is desired to determine the exchangeable amounts of specific metals, transfer the original ammonium acetate filtrate to an appropriate-sized beaker. Rinse the collection flask with 10 ml 10 percent acetic acid and add to the beaker. Evaporate the samples to dryness on a steam bath to remove the ammonium acetate.

Digest the residue in 10 ml concentrated HNO_3 and 3 ml concentrated HClO_4 . When white HClO_4 fumes are evolved, remove the samples and allow to cool.

Add a small amount of distilled water to the digestate and filter through a 0.45- μ pore-size membrane filter. Collect the filtrate in a volumetric flask. Rinse the beaker with distilled water, filter, and add to the volumetric flask.

Dilute to volume with distilled water and analyze for the metal(s) of choice.

Calculations

The CEC of the sediment is reported in meq/100 g and is calculated as follows:

$$\text{CEC}/100\text{g} = \frac{(X \text{ mg}/\ell) (0.5) (100)}{(18 \text{ mg}/\text{meq}) (g) (\% S)}$$

where

- X = ammonia concentration in NaCl leachate, mg/ ℓ
- 0.5 = volume of NaCl leachate, ℓ
- 18 = millequivalent weight of ammonium ion, mg/meq
- g = weight of sediment sample, g
- % S = percent solids in sediment sample (as decimal fraction)

The exchangeable metal concentration (EMC) is calculated as follows:

$$\text{EMC meq/100g} = \frac{(y) (v) (100)}{(\text{meq}) (g) (\% S)}$$

where

y = metal concentration in the ammonium acetate leachate, mg/l

v = final volume of acid digest, l

meq = milliequivalent weight of metal, mg/meq

g = weight of sediment sample, g

% S = percent solids in sediment sample (as decimal fraction)

Method 2: Centrifugation

The following method for CEC determination is essentially the same as the first method except phase separations are accomplished with a centrifuge rather than filtration. Reagents are the same.

Procedure

Weigh out a 5-g sample of homogenized sediment and transfer to a 50-ml centrifuge tube.

Add 33 ml 1 N ammonium acetate solution. (It has been found to be convenient to use a repipet for this procedure.) Shake each sample and let the suspension stand for 30 min. Shake the suspensions and centrifuge for 10 min at 2000 rpm with a table top centrifuge. Decant the ammonium acetate solution and save for exchangeable metal concentrations.

Repeat the above procedure with a second and a third 33-ml portion of ammonium acetate. Combine the ammonium acetate solutions.

Add 33 ml 80 percent ethanol to the sediment residue in the centrifuge tube. Shake the tubes and centrifuge for 10 min at 2000 rpm. Decant the ethanol layer and discard. Repeat the ethanol washing procedure two times.

Add 33 ml 10 percent sodium chloride solution to the washed sediment residue and shake. Centrifuge the sample and decant the liquid phase into a 100-ml volumetric flask. Repeat the process with two 33-ml portions of 10 percent sodium chloride. Add the sodium

chloride decantate to the volumetric flask and dilute to volume.

Analyze the sediment leachate for ammonia.

If specific exchangeable metals are to be determined, evaporate the combined ammonium acetate extract to dryness on a steam bath. Add 100 ml concentrated HNO_3 and 3 ml concentrated HClO_4 . Heat on a hot plate until HClO_4 fumes begin evolving.

Cool the sample and add a small amount of distilled water. Filter through a 0.45- μ pore-size membrane filter and collect in a volumetric flask. Dilute to volume and analyze for the metal(s) of interest.

Calculations

The calculations are the same as for the first method except the volume of NaCl leachate is 0.1 l instead of 0.5 l.

References

1. Black, C. A. Methods of Soil Analysis. American Society of Agronomy and American Society of Testing Materials; Madison, Wisconsin. 1572 p. (1965).
2. Toth, S. J., and Ott, A. N. "Characterization of Bottom Sediments: Cation Exchange Capacity and Exchangeable Cation Status." *Envir. Science and Tech.* 4:935-939 (1970).
3. Jackson, M. L. Soil Chemical Analysis. Prentice-Hall, Inc.; Englewood, New Jersey. 498 p. (1960).
4. Plumb, R. H., Jr. "A Study of the Potential Effects of the Discharge of Taconite Tailings on Water Quality in Lake Superior." Ph.D. Thesis, University of Wisconsin-Madison. 550 p. (1973).

PARTICLE SIZE

Particle-size distribution is a cumulative frequency distribution or a frequency distribution of relative amounts of particles in a sample within specified size ranges.^{1*} The size of a discrete particle is usually characterized as a linear dimension and designated as a diameter. It should be recognized that the use of sieves and settling tubes will result in a separation based on particle shape as well as particle size. Therefore, the following definitions are presented for comparison of terms that may appear in the technical literature:²

- a. The nominal diameter of a particle is the diameter of a sphere that has the same volume as the particle.
- b. The sieve diameter of a particle is the diameter of a sphere equal to the length of the side of a square sieve opening through which the given particle will just pass.
- c. The standard fall velocity of a particle is the average rate of fall that the particle would attain if falling alone in quiescent, distilled water of infinite extent and at a temperature of 24°C.
- d. The standard fall diameter, or simply fall diameter, of a particle is the diameter of a sphere that has a specific gravity of 2.65 and has the same standard fall velocity as the particle.
- e. The sedimentation diameter of a particle is the diameter of a sphere that has the same specific gravity and terminal uniform settling velocity as the given particle in the same sedimentation fluid.
- f. The standard sedimentation diameter of a particle is the diameter of a sphere that has the same specific gravity and has the same standard fall velocity as the given particle.
- g. The size distribution, or simple distribution, when applied in relation to any of the size concepts, is the distribution of material by percentages or proportions by weight.

Particle size may be reported as class, millimeters, micro-

* References for this procedure are on page 3-47.

meters, or a phi value. A comparison of these four size scales is presented in Table 3-2. A comparison of instrument capabilities based on cost and particle size range is presented in Table 3-3.

The size distribution of sediments can be of importance because it can affect the distribution of chemicals in the aquatic environment. Specifically, sediments can remove chemical contaminants from water by the process of sorption. Further, since sorption is a surface phenomena, the smaller particle sizes generally have a higher concentration of these chemical contaminants on a weight/weight basis.

There is a certain amount of arbitrariness associated with particle-size analysis. One method relies on the treatment of the sample with hydrogen peroxide to destroy organic matter that may be causing the sediment particles to aggregate. While this approach will define the true particle-size distribution of the sample, the results will not be representative of the surface area potentially available for sorption or exchange reactions. On the other hand, sizing of sediments without peroxide treatment would yield results more representative of the exposed surface area but the apparent particle-size distribution may be affected by the method of sample handling prior to sizing.

Sample Handling and Storage

Samples scheduled for particle-size analysis may be stored in either plastic or glass containers. The samples should be chilled at 4° to 5°C but never frozen prior to analysis. If samples cannot be analyzed within a few hours, Lugols solution should be added as a preservative to minimize the effects of bacterial growth.

Particle-size analysis of suspended solids in water will require 500 to 2000 ml. The exact volume will depend on the suspended solids concentration of the sample. The required amount of sediment will range from approximately 3 to 25 g, depending on the size distribution. Should the sample contain a large percentage of coarse sand and gravel, a larger sample size should be used to ensure that the smaller

Table 3-2
Comparison of Scales Used to Report Particle Size Results

<u>Class Name</u>	<u>Millimeters</u>	<u>Micrometers</u>	<u>Phi Value</u>
Boulders	>256		<-8
Cobbles	256 - 64		-8 to -6
Gravel	64 - 2		-6 to -1
Very coarse sand	2.0 - 1.0	2,000 - 1,000	-1 to 0
Coarse sand	1.0 - 0.50	1,000 - 500	0 to +1
Medium sand	0.50 - 0.25	500 - 250	+1 to +2
Fine sand	0.25 - 0.125	250 - 125	+2 to +3
Very fine sand	0.125 - 0.062	125 - 62	+3 to +4
Coarse silt	0.062 - 0.031	62 - 31	+4 to +5
Medium silt	0.031 - 0.016	31 - 16	+5 to +6
Fine silt	0.016 - 0.008	16 - 8	+6 to +7
Very fine silt	0.008 - 0.004	8 - 4	+7 to +8
Coarse clay	0.004 - 0.0020	4 - 2	+8 to +9
Medium clay	0.0020 - 0.0010	2 - 1	+9 to +10
Fine clay	0.0010 - 0.0005	1 - 0.5	+10 to +11
Very fine clay	0.0005 - 0.00024	0.5 - 0.24	+11 to +12
Colloids	<0.00024	<0.24	>+12

Table 3-3
Comparison of Particle-Size Distribution Analytical Methods³

<u>Initial Cost, \$</u>	<u>Analytical Method</u>	<u>Size Range, μm</u>	<u>Approximate Analysis Cost, \$</u>
500 - 1,000	Optical microscope	1 to 1,000	40
	Sieves	1 to 1,000	20
	Simple sedimentation	5 to 1,000	40
10,000	Optical microscope	0.5 to 1,000	40
	Electron microscope	0.2 to 10	20
	Centrifugal sedimentation	0.2 to 50	20
	Sedimentation	0.2 to 50	20
10,000 - 100,000	Electron microscope	0.1 to 10	40
	Scanning electron microscope	0.1 to 100	200
	Stream counting	0.1 to 100	10
	Instrumented microscope	0.5 to 1,000	20
	Scanning electron microscope	0.1 to 100	200
100,000+	Scanning electron microscope	0.1 to 100	200

size classes are being representatively sampled.

It is recommended that particle-size samples not be frozen or dried prior to analysis (Figure 3-3). The basis of this recommendation is that the freezing-thawing cycle or sample drying may cause an irreversible change in the particle-size distribution due to oxidation and/or agglomeration.

Method Selection

Particle-size analysis of a sediment sample will usually require the use of two or more methods because of the wide range of particle sizes encountered. The useful size range and amount of sample required for each method are presented below:¹

<u>Method</u>	<u>Size Range, mm</u>	<u>Concentration, mg/l</u>	<u>Sediment quantity, g</u>
Sieves	0.062 - 32	-	-
Particle Counters	0.0002 - 0.062	-	-
V. A. Tube	.062 - 2	-	0.05 - 15.0
Pipette	0.002 - 0.062	2,000 - 5,000	1.0 - 5.0

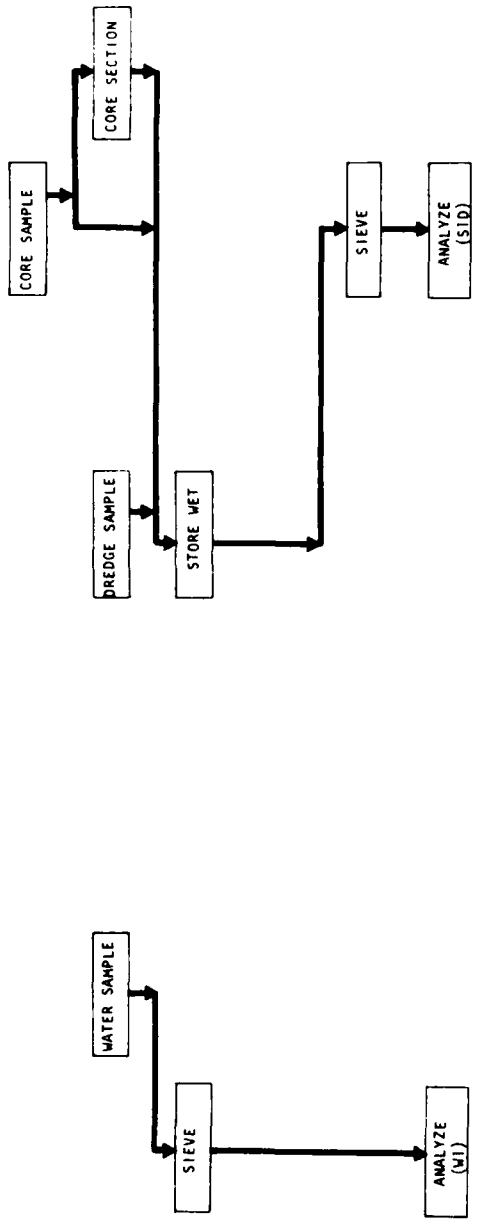

3-32

SAMPLE DESIGNATION	WI	SID
PURPOSE	Total Water Conc.	Sediment Particle-Size Distribution
CONTAINER	G,P	G,P
SAMPLE TREATMENT	None	None
PRESERVATIVE	Lugols	None
STORAGE TIME	Storage Time Not Critical Unless Bacterial Growth Occurs.	-
SAMPLE VOLUME OR WEIGHT	0.5-2.0 ml	25 g

Figure 3-3. Handling and storage of samples for particle size analysis

Procedures for Sediment Samples (SID)

Method 1: Sieving and Electronic Particle Counters

Apparatus

Nest of U. S. standard sieves ranging from #230 (62 μ) up to #18 (1000 μ)

Ro-Tap apparatus for sieving

Coulter counter or equivalent electronic particle counter equipped with a 200- and 15- μ aperture

Magnetic stirrer

10-ml beakers

250-ml Erlenmeyer flasks

Evaporating dishes

Balance

Reagents

Calgon solution: dissolve 50 g commercially available Calgon in 1 ℓ distilled water. Filter solution through a 0.2 μ pore-size membrane filter prior to use.

NaCl electrolyte solution: dissolve 25 g NaCl electrolyte solution in 1 ℓ distilled water. Filter solution through a 0.2- μ pore-size membrane filter prior to use.

Procedure

Blend the sediment sample and weigh out 5.0 to 25.0 g wet sediment. Add 5 ml Calgon solution and blend for 30 sec. Wash container sides with distilled water and blend for an additional 30 sec.

Wet sieve the suspension through a #230 U. S. standard sieve. Collect the material retained on the sieve for size analysis (Fraction 1). Collect the filtrate in tared beakers (Fraction 2).

Dry, cool, and weigh the Fraction 2 samples. This will provide information to calculate the weight percent of total silt and clay in the sample.

Dry and cool Fraction 1. Record the weight of this fraction. Place sample on a nest of standard sieves ranging from a #18 standard sieve (1000 μ) to a #120 standard sieve (125 μ). Weigh each individual fraction. This information will allow calculation of the -1 phi-size to +3 phi-size fractions.

Weigh out a second 5.0- to 25-g blended aliquot of the original sample. Add 5.0 ml Calgon solution and blend as before. Wet sieve the sample through a #230 U. S. standard sieve and collect the filtrate in a 250-ml flask and dilute to volume with distilled water (Fraction 3).

Determine the size distribution of Fraction 3 using an electronic particle counter such as the Coulter counter. Follow manufacturer's directions to set up the instrument. Allow 15 min for warmup.

Filter a supply of electrolyte through a 0.2- μ filter. Set the calibration potential and milliamp controls according to the manufacturer's instructions. Count the filtered electrolyte using a 30- μ tube. The background count should be less than 400 with the shield door closed.

Place the 200- μ tube on the sample stand and turn aperture slightly clockwise. Position the tube slightly away from the beaker. Adjust the calibration potential and milliamp settings, if necessary. Set the gain switch to auto, active channel switch to 15-2, sampling switch to time, mode switch to volume, and display gain switch to X10. Set the stirring motor to a proper rpm and be sure the propeller is centered in the bottom of the beaker. (The mixing process should not cause surface turbulence.)

Place Fraction 3 on a magnetic stirrer and mix. While the sample is being mixed, withdraw three equal-sized subsamples from the suspension: one from the top, middle, and bottom of the flask. Never take the bottom subsample against the bottom of the flask. The subsample volume will depend on the sediment concentration but 3- to 5-ml aliquots should provide adequate sample.

Transfer the subsamples to a clean 200-ml beaker and dilute to volume with filtered 2.5 percent NaCl electrolyte solution. Using a 200- μ aperture, run the sample through channels 6 to 15 of a Coulter counter for 60 sec.

Open the control stopcock above the tube. Open the auxiliary stopcock just long enough to clear bubbles from the tube. Push reset button. Bring the concentration index meter to 0.03. (If the concentration is above 0.03, add more electrolyte to dilute to 0.03. If the concentration is below 0.03, add more subsamples from Fraction 3 until 0.03 is reached.) The final concentration should also be less than 10,000 particles/2 ml at manometer setting 15-2.

Switch back to time and open stopcock. After pushing reset, wait 4 sec, then push accumulate. When the calibration light comes on, push stop and close tube stopcock.

Record the total count data from each channel.

Drain residual electrolyte to a standard volume (130 ml) for 15- μ tube analysis. Transfer sample to a clean 250-ml storage beaker rinsed with filtered electrolyte for analysis with a 15- μ tube. Cover storage beaker with cellophane to avoid contamination. The 15- μ tube analysis should be completed within 2 hr of the 200- μ analysis.

Change to the 15- μ aperture tube and set the instrument controls as follows: active channel switch to 14-3, and gain control to automatic. Set the calibration potential and milliamp controls as required. Select the proper overlap channel with the channel selector switch.

Pour the sample saved from the 200- μ analysis through a clean 10- μ micromesh sieve into a clean electrolyte beaker. (The sieve should be washed with filtered electrolyte prior to use.) Immediately place the beaker on the sample stand and open the tube stopcock. Open auxiliary stopcock to clear bubbles from the tube and push the reset button.

Do not use the stirring motor. Push accumulate button and stop when the calibration light comes on. Switch gain control to manual and match difference percent from channel 14 with the difference percent from channel 5 of the 200- μ tube analysis. Record the data from each channel.

- NOTE 1: Always keep tinfoil shield door closed during analysis.
- NOTE 2: Make sure bubbles are clear from tube aperture by opening both stopcocks.
- NOTE 3: If tube clogs, brush aperture opening. If tube is still clogged, clear with an ultrasonic dismembrator.
- NOTE 4: Always have aperture current in off position when not running an analysis.
- NOTE 5: Check calibration and automatic gain control weekly.

Calculations

Record the total weight of the sand (Fraction 1) and the silt plus clay (Fraction 2) fractions. Weigh and record the weight of each of the larger size fractions based on the dry sieving results (Table 3-4). The exact number of size fractions will depend on the number of sieves used. The percentage of each size fraction can be calculated by dividing the weight on each sieve by the total weight of the sample.

Record the Coulter counter data in a form similar to Table 3-5. One fraction was counted with an aperture of 200 μ . These channel counts are designated 16-A, 15-A, 14-A, etc. (The number refers to the channel number and the letter refers to the 200- μ aperture sample.) Results for the 15- μ aperture sample are designated 14-B, 13-B, etc.

NOTE: When counting the 15- μ aperture sample, the Coulter counter should be calibrated such that the 6-A reading is equal to the 14-B reading.

The numerical sum of three consecutive channels is proportional to one phi size. Therefore, for the stated conditions, the sum of 16-A, 15-A, and 14-A is the 4 phi-size fraction. The total of 13-A, 12-A, and 11-A is the 5 phi-size fraction, etc. These totals are designated size fraction A-H in Table 3-5 and are equivalent to phi fractions 4-11.

The following approach is used to calculate the percentage of each phi fraction in the original sample:

$$\% \text{ 4 phi} = \frac{W}{X} \cdot \frac{Y}{Z} \cdot 100$$

Table 3-4

Data Tabulation for Sand-Size Fractions

Sample No. _____
Analyst _____
Date _____

Sand Fraction (Fraction 1) _____ g
Sand and Clay Fraction (Fraction 2) _____ g

Total Sample Weight

Coarse Fraction

<u>ϕ Size</u>	<u>Dish #</u>	<u>Dish wt, g</u>	<u>Dish and Sed, g</u>	<u>Cumulative wt, g</u>	<u>% Larger</u>
-3					
-2					
-1					
0					
1					
2					
3					
4					

Table 3-5
Data Tabulation for Coulter Counter Results for
Silt- and Clay-Sized Fractions

Sample No.	_____	Sand Fraction	_____
Analyst	_____	Silt and Clay Fraction	_____
Date	_____	Total Sample Weight	_____

<u>Size Fraction</u>	<u>Coulter Reading</u>	<u>Relative Abundance</u>	<u>% Phi</u>
A	16-A		
	15-A		
	14-A	<u>4</u>	
B	13-A		
	12-A		
	11-A	<u>5</u>	
C	10-A		
	9-A		
	8-A	<u>6</u>	
D	7-A		
	6-A/14-B	<u>7</u>	
E	13-B		
	12-B		
	11-B		
F	10-B	<u>8</u>	
	9-B		
	8-B		
G	7-B	<u>9</u>	
	6-B		
	5-B		
H	4-B	<u>10</u>	
	3-B		
	2-B		
	1-B	<u>11</u>	

where:

W = sum of three consecutive channels

X = total for size fractions A-H

Y = total weight of the silt and clay fraction in the original sample
(Fraction 2), g

Z = total weight of the original sample (silt and clay and sand), g

Method 2: Sieving and Pipet Analysis

Apparatus

8-in. stainless steel 63- μ sieve (wet sieve)

Distilled or demineralized water

Receiving container to fit under wet sieve, volume > 1000 ml

Drying oven

Mortar and pestle

8-in. stacking sieves: 7 at 1-phi intervals, -2 phi to +4 phi; 1/2-phi intervals should also be available and can be used if desired.

Sieve shaker (Ro-Tap or equivalent)

Weighing dishes

Balance to 0.0001 g

1000-ml graduated cylinders

20-ml pipets with controlled fill bulbs

Stirring rods

Constant temperature bath

50-ml preweighed beakers

Clock with second hand

Thermometer, in 1°C divisions or better

Dessicator

Reagents

10 percent hydrogen peroxide, H₂O₂.

1 percent Calgon: dissolve 10 g commercially available Calgon in 1 l of distilled water.

Procedure

Homogenize the sample by mixing or mechanically tumbling.

Remove a 40- to 150-g subsample. The smaller size is generally suitable for fine-grained sediments while the larger size is needed when the

particle sizes are well distributed. A flow diagram summarizing the procedure is presented in Figure 3-4. The next step is optional. If it is desired to determine the true sample particle-size distribution, treat the sample with hydrogen peroxide as indicated to destroy organic matter prior to sizing.

If it is desired to determine the apparent particle-size distribution, omit the treatment with hydrogen peroxide and proceed as indicated.

Place the sediment sample in a large beaker ($\geq 2\ell$) and add 20 ml 10 percent hydrogen peroxide. Let the sample stand until frothing ceases and add an additional 10 ml hydrogen peroxide. Continue the incremental addition of hydrogen peroxide until no frothing occurs on addition.

Boil the sample to remove any excess hydrogen peroxide. This should be completed in a large beaker to prevent sample loss due to boiling over or frothing.

Separate the sample into coarse and fine fractions by wet sieving through a 63- μ stainless steel sieve. If possible, the quantity of distilled or demineralized water used in the sieving process should be kept below 900 ml. Continue wet sieving until only clear water passes through the sieve. Collect the fine fraction that passes through the sieve and retain the coarse fraction on the filter.

NOTE: Never wet sieve using a brass sieve and always wet seive at room temperature.

Coarse fraction. Transfer the coarse fraction to a beaker using tap water. Dry the sample in an oven at a temperature not exceeding 50°C. The temperature limitation is a precaution against sample splattering or particles cementing together.

Transfer dry sample to a dessicator for cooling. Disaggregate sample, if necessary, with a porcelain mortar and pestle.

Transfer the dried sediment sample to a preweighed beaker and determine the weight of the sediment sample.

Build a nest of U. S. standard sieves of the required phi sizes with the coarsest sieve on the top and the finest sieve on the

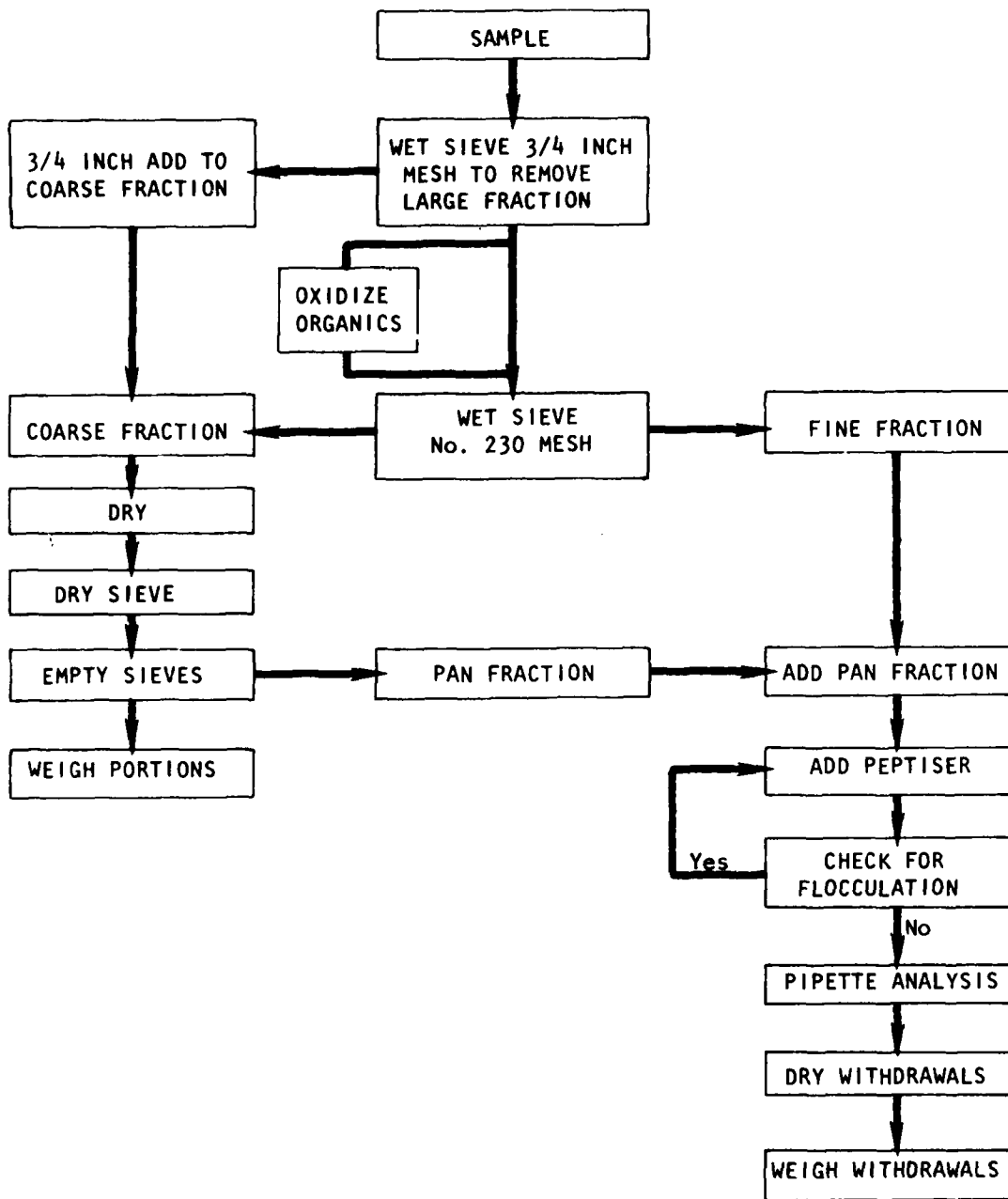

Figure 3-4. Particle-size procedure using sieving/pipet analysis

bottom. Place a pan on the bottom, add the sample to the top sieve, and place a lid on the nest of sieves.

Place the nest of sieves on a Ro-Tap (or equivalent) mechanical shaker and shake for 10 to 15 min. Empty each sieve onto a large piece of paper. Invert each sieve on a piece of paper, lightly tap the screen, and brush the particles from the screen. Do not touch screens with your fingers.

NOTE: Brushes should be of softer material than the screen material, i.e. steel brushes on sieve sizes of 1 phi or greater, brass or nylon brushes on stainless steel screens, and nylon brushes on brass screens.

Weigh and record each size fraction. If the weight on any one sieve exceeds the value in Table 3-6, the sample should be recombined, coned and quartered or split, and sieved again.

Table 3-6
Maximum Sieve Loads on 8-in-diam Sieves
for 1-phi Intervals

Sieve Size		Maximum allowable retention
phi	mm	g
-2.00	4	160
-1.00	2	110
0.00	1	80
+1.00	1/2	60
+2.00	1/4	40
+3.00	1/8	30
+4.00	1/16	20

The sum of all individual size fractions should be approximately equal to the original sample weight. Sample losses and inaccuracies should be less than 1 percent.

Fine fraction. Allow the fine fraction from the initial sieving to stand until all silts and clays settle out. Remove the clear water by careful decantation or siphoning. If, after 24 hr, sediment particles are still in suspension, measure the volume of water decanted. Sample the decanted water and determine the suspended

solids concentration. Calculate the weight of sample lost (volume \times concentration) and correct results for this loss.

Transfer the fine fraction to the metal cup of a malt blender and add 10 ml 1 percent Calgon solution. The Calgon acts as a peptizer to prevent the flocculation of sediment particles. Mix the suspension on a blender and transfer to a 1000-ml graduated cylinder. Add distilled or demineralized water to a volume of approximately 900 ml. Mix.

Let the sample stand for 2 to 3 hr and observe for flocculation. If a definite clearing occurs, add 10 ml 1 percent Calgon and repeat the process until no noticeable flocculation occurs. Record the volume of Calgon solution added.

Dilute the sediment suspension to 1000 ml with either distilled or demineralized water. Thoroughly mix the sample. Immediately withdraw a 20-ml sample from a depth of 20 cm and determine the wet weight of sediment withdrawn. The total weight of sediment in the graduated cylinder should be approximately 15 g and between 5 and 25 g. If the total sample contains more than 25 g, a subsample should be used for pipet analysis. This can be obtained by pouring the complete sample through a splitter trough or pouring off part of the well-mixed sample and diluting the remainder.

Place the graduated cylinder in a constant temperature bath for the duration of the analysis as water viscosity, which varies with temperature, can affect sediment settling properties. Immerse the cylinder to the 1000-ml mark and firmly clamp in place for stability.

Adjust the sample volume to 1000 ml, if necessary, and thoroughly stir the sample. Make sure that any settled sediment is completely dispersed.

About 15 sec after the stirring is stopped, insert a 20-ml pipet to a depth of 20 cm. (It is convenient to mark the stem of the pipet 10 and 20 cm from the tip.) Withdraw the sample so the pipet is full before 20 sec has elapsed since stirring was stopped. Transfer the sample to a preweighed 50-ml beaker. Wash the pipet with distilled water and add the rinsing to the beaker.

Withdraw 20-ml samples from a depth of 10 cm at the times

indicated in Table 3-7. If necessary, samples may be collected at half the indicated times and half the indicated depths. Transfer the samples to preweighed, 50-ml beakers.

Dry the sample containing beakers at a temperature less than 100°C. Do not allow the samples to boil as this may result in loss of samples.

Transfer the beakers to a dessicator and cool. Weigh samples to the nearest 0.0001 g.

Calculations

The data for both the coarse fraction and the fine fraction should be recorded in tabulated form as shown in Table 3-8. It should be noted that the weights of the samples withdrawn during the pipet analysis are automatically cumulative while those of the dry sieving are not. Also note that a correction for the peptizer must be included in the pipet analysis results. In addition, the calculation of the percent finer and percent larger data uses the total sample weight (i.e. weight of fine fraction plus the coarse fraction).

The total weight of the fine fraction is determined from the sampling of the peptized sediment suspension. The total weight of each fine fraction is calculated by multiplying the sample weight by 50. If the initial sample volume is something other than 1000 ml and/or the sample size is something other than 20 ml, this factor must be appropriately corrected.

Table 3-7
Sampling Time Intervals for Pipet Analysis

Diameter finer than phi		Elapsed time for withdrawal of sample in hours (h), minutes (m), and seconds (s)										
μ	cm	18°C	19°C	20°C	21°	22°C	23°C	24°C	25°C	26°C	27°C	
4.0	62.5	20s	20s	20s	20s	20s	20s	20s	20s	20s	20s	
4.5	44.2	2m0s Restir	1m57s Restir	1m54s Restir	1m51 Restir	1m49s Restir	1m46s Restir	1m44s Restir	1m41s Restir	1m39s Restir	1m37s Restir	
5.0	31.2	2m0s	1m57s	1m54s	1m51s	1m49s	1m46s	1m44s	1m41s	1m39s	1m37s	
5.5	22.1	4m0s	3m54s	3m48s	3m42s	3m37s	3m32s	3m27s	3m22s	3m18s	3m13s	
6.0	15.6	8m0s	7m48s	7m36s	7m25s	7m15s	7m5s	6m55s	6m45s	6m36s	6m27s	
7.0	7.8	31m59s	31m11s	30m26s	29m41s	28m59s	28m18s	27m39s	28m1s	26m25s	25m49s	
8.0	3.9	63m58s	62m22s	60m51s	59m23s	57m58s	56m36s	55m18s	54m2s	52m49s	51m39s	
9.0	1.95	4h16m	4h9m	4h3m	3h58m	3h52m	3h46m	3h41m	3h36m	3h31m	3h27m	
10.0	0.98	17h3m	16h38m	16h14m	15h50m	15h28m	15h6m	14h45m	14h25m	14h5m	13h40m	
11.0	0.49	68h14m	66h32m	64h54m	63h20m	60h50m	60h23m	58h59m	57h38m	56h20m	55h5m	

Table 3-8

Typical Particle-Size Distribution Data Sheet

Sample No. _____

Analyst _____

Date _____

Total Sample Weight = Coarse _____ g + Fine _____ g = _____ g

Fine Fraction (Pipette Analysis)

Peptizer (1% Calgon) added _____ ml

Peptizer Correction Factor wt/20 ml Sample = _____ g

Water Bath Temperature _____ °C

Fine Fraction

<u>φ Size</u>	<u>Dish #</u>	<u>Dish wt</u> g	<u>Dish and Sed</u> g	<u>Less Peptizer</u> g	<u>Total wt</u> g	<u>% Finer</u>
4						
5						
6						
7						
8						
9						

Coarse Fraction

Initial wt _____ g

<u>φ Size</u>	<u>Dish #</u>	<u>Dish wt</u> g	<u>Dish and Sed</u> g	<u>Cumulative wt</u> g	<u>% Larger</u>	<u>Comments</u>
-5						
-4						
-3						
-2						
-1						
0						
1						
2						
3						
4						

References

1. U. S. Geological Survey. "National Handbook of Recommended Methods for Water Data Acquisition." Office of Water Data Coordination, Geological Survey, U. S. Department of the Interior; Reston, Virginia (1977).
2. Guy, H. P. "Techniques of Water-Resources Investigation of the United States Geological Survey." Chapter C1. "Laboratory Theory and Methods for Sediment Analysis." 59 p. (1973).
3. Fochtman, E. G. "Selection of a Particle Size Measurement Instrument." In: Particle Size Analysis; Stockman, J. D., and Fochtman, E. G. (Eds.). pp. 125-129. Ann Arbor Science Publ. 140 p. (1978).
4. Walton, A. "Methods for Sampling and Analysis of Marine Sediments and Dredged Material." Scientific Information and Publications Branch, Fisheries and Marine Service, Department of Fisheries and the Environment; Ottawa, Ontario, Canada. 74 p. (1978).

pH

The pH of a solution is a measure of the hydrogen ion activity. It is mathematically expressed as the negative logarithm of the hydrogen ion concentration. This parameter is important because it is used to calculate the species distribution of weak acids and bases such as carbonates, ammonia, and cyanide that may be present in the sample. Acid-base equilibria is important because the toxicity of a sample can vary with the distribution of chemical species. The recommended analytical method is electronic measurement using glass electrodes.

Sample Handling and Storage

Whenever possible, pH measurements should be taken and recorded in situ. If necessary, the sample can be returned to the laboratory in either glass or plastic containers. However, the measurements should be completed as soon as possible as there is no known method of preserving sample pH. It is also recommended that sample containers be completely filled and tightly sealed when pH analyses are to be run on a delayed basis. This precaution is intended to minimize the exchange of carbon dioxide that can alter pH. Additionally, sample should be kept in the dark and refrigerated.

Sample Preparation

The only required preparation is to ensure that the samples to be measured and the standard pH buffers are equilibrated at the same temperature.

Procedures for Water Samples (W1, W2, S1A)

Method 1: Glass Electrode

Apparatus

Electronic pH meter: a meter with a temperature compensation adjustment would be preferred but not required

Glass electrode: if pH values greater than 10 and high sodium concentrations are anticipated, minimum sodium error electrodes should be selected

Reference electrode such as the saturated calomel capable of maintaining a constant potential

Magnetic stirrer and stirring bars

Reagents

Standard pH buffers throughout the anticipated range of sample pH values. Prepared buffer solutions and dry powders are available commercially. For more accurate work, fresh buffer solutions can be prepared as needed.

Procedure

Follow manufacturer's directions to set up and warm up the pH meter. Adjust the temperature compensator to the temperature of the samples and buffers.

Select two buffer solutions in the approximate range of the samples to be measured. Place the first buffer in a beaker and stir gently on a magnetic stirrer. Lower the electrodes in the buffer and allow the meter needle to stabilize. Adjust the instrument calibration control to the correct buffer value.

Remove the electrodes from the buffer solution and rinse with distilled water. Gently dry the electrodes with soft, absorbent tissue.

Place the second buffer solution in a beaker and stir gently on a magnetic stirrer. Lower the electrodes in the buffer and allow the meter needle to stabilize. The reading should be within 0.1 pH units of the expected buffer value.

Remove the electrodes from the buffer, rinse, and dry as before.

Transfer 50 to 100 ml of a sample to be measured to a beaker and mix with a magnetic stirrer to ensure homogeneity. Immerse

the electrodes in the sample, allow the instrument to stabilize, and record the pH. It is a good practice to simultaneously measure the pH and the temperature of the sample because temperature affects dissociation constants of acids and bases and, hence, the significance of pH.

Continue processing samples, making sure to rinse and dry the electrodes between samples. Buffer solutions should be run approximately once an hour to check the instrument standardization.

Procedures for Sediment Samples (SID)

Method 1: Glass Electrode

Apparatus

Electronic pH meter: a meter with a temperature compensation adjustment would be preferred but not required

Glass electrode: if pH values greater than 10 and high sodium concentrations are anticipated, minimum sodium error electrodes should be selected

Reference electrode such as the saturated calomel capable of maintaining a constant potential

Magnetic stirrer and stirring bars

Reagents

Standard buffers throughout the anticipated range of sample pH values. Prepared buffer solutions and dry powders are available commercially. For more accurate work, fresh buffer solutions can be prepared as needed.

Procedure

Standardize the pH meter as described for water samples.

Transfer an aliquot of blended, moist sediment sample to an appropriate sized beaker. Do not use dried or frozen sediment samples as the dehydration process is not known to be reversible.

Insert the electrodes in the sample and allow the instrument to equilibrate. Record the pH and the temperature of the sample.

Clean the electrodes and process the next sample. Check the standardization of the pH meter at regular intervals using known buffer solutions.

If the sample is sufficiently dry that a direct pH reading cannot be taken, slurry the sediment with a known volume of distilled water. Report the pH of the slurry and the solid-liquid ratio of the slurry.

OXIDATION REDUCTION POTENTIAL

The oxidation-reduction potential (redox potential or Eh) is defined as the electromotive force developed by a platinum electrode immersed in a water or sediment sample relative to a standard hydrogen electrode or a reference electrode of known Eh. The obtained value is a crude estimate of the oxygen status of the sample. A positive value indicates that the water or sediment sample is in an oxidized state or oxygen is present. A negative value would indicate an absence of oxygen or reducing conditions.

Sample Collection and Storage

The preferred method of obtaining oxidation-reduction potential data is in situ measurement. If this is impractical, the measurements should be made as soon as possible. Since exposure to the atmosphere may affect the oxidation-reduction potential of the sample (oxygen may dissolve in water or oxidize sediments), precautions should be taken to minimize sample contact with the atmosphere prior to measurement of the oxidation-reduction potential. This precaution will necessitate the use of wet sediment samples for the measurement.

Procedure for Water (W1, W2, S1A) and Sediment Samples (S1D)

Method 1: Platinum Electrode

Apparatus

Potentiometer or pH meter equipped to read in millivolts

Saturated potassium chloride calomel cell

Platinum electrode with clean platinum surface

Procedure

Insert the platinum electrode into the W1 water sample or the S1D sediment sample and allow the instrument to equilibrate.

Record the instrument millivolt reading.

Calculations

Sample potential = (measured millivolt reading)
- (standard calomel potential)

TOTAL SOLIDS AND VOLATILE SOLIDS

Total solids or total residue refers to the material remaining after a sample has been dried or evaporated at a specific temperature. The residue, therefore, includes both soluble and suspended solids in the original sample. The procedure should be considered operationally defined to the extent that slightly different results can be obtained if samples are dried at temperatures other than those specified. These differences would be expected to be more pronounced for sediment samples than for water samples.

Volatile solids procedures have been included in this section because the residue from the total solids determination is used as the starting material. The solids are subjected to ignition at a higher temperature to provide a crude estimate of the organic matter in the total solids. The use of temperature to distinguish between organic and inorganic solids, however, should be used with caution because some organic material can be lost at the lower drying temperature and some inorganic material (carbonates and chlorides) can be lost at the higher ignition temperatures, particularly with sediment samples.

Sample Handling and Storage

The suggested method of handling total solids and total volatile solids samples is presented in Figure 3-5. Only moist sediment samples should be used for this determination. Either glass or plastic containers can be used for storing the samples. However, the storage period should be kept to a week or less.

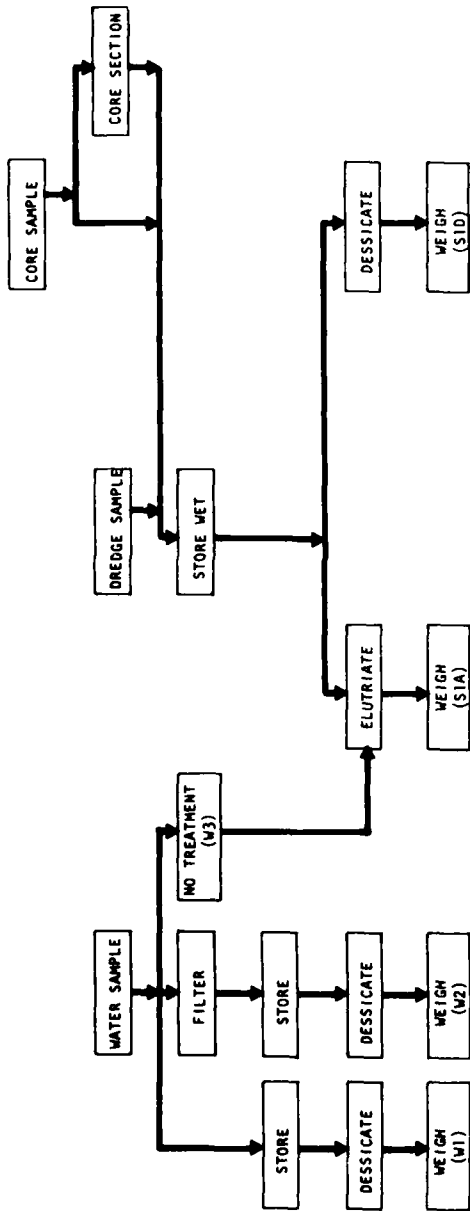

SAMPLE DESIGNATION	W1	W2	W3	SIA	SID
	Total Solids or Total Residue	Soluble or Filtrable Residue	Used in Elutriate	Mobile Conc.	Percent Solids
PURPOSE					
CONTAINER	G,P	G,P	G,P	G,P	G,P
SAMPLE TREATMENT	None	Filter	None	None	None
PRESERVATIVE	4°C	4°C	4°C	4°C (Minimize Air Contact. Keep Field Moist)	4°C
STORAGE TIME	1w	1w	1w	1w	-

Figure 3-5. Handling and storage of samples for total solids and volatile solids analysis

Total Solids
Procedure for Water Samples (W1, W2, S1A)

Method 1: Gravimetric

Apparatus

Evaporating dishes of 100-ml capacity, either porcelain, platinum, or Vycor

Muffle furnace for operation at $550 \pm 50^{\circ}\text{C}$

Steam bath or drying oven

Desiccator

Analytical balance

Procedure

Ignite a clean evaporating dish at $550 \pm 50^{\circ}\text{C}$ for 1 hr in a muffle furnace. Cool, desiccate, and weigh the dish. Record the weight of the empty dish and store the evaporating dish in a desiccator until used.

Transfer a known volume of W1, W2, or S1A sample to the preweighed dish and evaporate to dryness on a steam bath or in a drying oven. It is recommended that a sample size be chosen that will produce a minimum residue of 25 mg. With low residue waters, successive aliquots of the sample should be added to the same evaporating dish until the required minimum residue is obtained.

Exclude large, nonhomogeneous materials from the sample. Also, uniformly disperse any floating oil and grease before subsampling.

When drying in an oven, evaporate the sample at 98°C . This precaution is necessary to prevent loss of sample by boiling and splattering and, hence, low results.

After evaporation, increase the drying oven temperature from 98°C to 103° to 105°C or transfer the evaporating dish from the steam bath to a drying oven set at 103° to 105°C . Dry the sample for 1 hr at 103° to 105°C . Cool, desiccate, and weigh the sample. Repeat the 1-hr drying cycle at 103° to 105°C until a constant weight is obtained for the residue. The gain in weight of the tared evaporating dish is a measure of the solids or residue of the sample.

Calculations

The solids concentration of the sample is calculated by dividing the weight of the residue by the volume of sample used:

$$\text{mg/l residue} = \frac{(A - B) \times 1000}{V}$$

where

A = weight of dish and sample residue, mg

B = weight of dish, mg

V = volume of sample aliquot, ml

When a W1 sample is used, the results should be termed total solids or total residue. When a W2 or S1 sample is used, the results should be termed total filterable solids or total filterable residue.

Total Solids
Procedure for Sediment Samples (SID)

Method 1: Gravimetric

Apparatus

Evaporating dishes of 100-ml capacity, either porcelain, platinum, or Vycor

Muffle furnace for operation at $550 \pm 50^{\circ}\text{C}$

Steam bath or drying oven

Desiccator

Analytical balance

Procedure

Ignite clean evaporating dishes at $550 \pm 50^{\circ}\text{C}$ for 1 hr in a muffle furnace. Cool, desiccate, and weigh each dish. Record the weight of each dish and store the dishes in a desiccator until used.

Homogenize an SID sample and transfer a 25-g aliquot to a tared evaporating dish. Weigh the sample-containing dish to the nearest 10 mg. Dry the sample overnight in a drying oven at 103° to 105°C . Cool the sample, desiccate, and weigh the sample. Repeat the drying process until a constant weight residue is obtained.

Calculations

The total solids or total residue of the sediment samples are calculated by dividing the weight of the dried residue by the initial weight of the sample. Results are termed % solids:

$$\% \text{ Solids} = \frac{A - B}{C - B} \times 100$$

where

A = weight of dish and dry sample residue

B = weight of dish

C = weight of dish and wet sample

Volatile Solids Determination

Volatile solids are determined by ashing the dried residue from the total solids, filterable solids, or percent solids determination at $550 \pm 50^{\circ}\text{C}$. The weight of material lost at the higher temperature is normalized to the initial volume or weight of sample and reported as percent volatile solids.

Apparatus

Evaporating dishes of 100-ml capacity, either porcelain, platinum, or Vycor

Muffle furnace for operation at $550 \pm 50^{\circ}\text{C}$

Desiccator

Analytical balance

Procedure

Preheat a muffle furnace to $550 \pm 50^{\circ}\text{C}$. Ignite the residue from the total solids (W1), filtrable solids (W2, S1A), and/or percent solids (S1D) determinations to a constant weight.

Remove the samples from the furnace and allow them to partially cool. Transfer the samples to a desiccator for final cooling. Weigh the sample dishes as soon as they are cool.

Calculations

The material lost on ignition is referred to as volatile solids or volatile residue. The material retained in the evaporating dish is referred to as fixed solids or fixed residue.

Water Samples:

$$\text{mg/l volatile residue} = \frac{(A - D) \times 1000}{V}$$

$$\text{mg/l fixed residue} = \frac{(D - B) \times 1000}{V}$$

where

A = weight of dish and dry sample residue

D = weight of dish and ignition residue

V = volume of original sample, ml

B = weight of evaporation dish

Sediment Samples:

$$\% \text{ volatile residue} = \frac{A - D}{A - B} \times 100$$

$$\% \text{ fixed residue} = \frac{D - B}{A - B} \times 100$$

where

A = weight of dish and dry sample residue

B = weight of evaporation dish

D = weight of dish and ignition residue

SPECIFIC GRAVITY

The specific gravity of a substance is defined as the ratio of the mass of a given volume of the substance to an equal volume of distilled water at the same temperature. Since the specific gravity of water is 1 g/cc, the specific gravity of the solid is equivalent to the grams of dry solid/cc.

Sample Handling and Storage

Since specific gravity is equivalent to the mass of dry solids per unit volume, sediment samples for this determination may be stored either wet, dried, or frozen.

Procedure for Sediment Samples (S1A, S2, S3)¹

Apparatus

Constant volume pycnometer
Drying oven
Thermometer
Balance
Distilled water

Procedure

Fill pycnometer with distilled water and weigh to the nearest 0.1 mg. Record the temperature of the water.

Weigh a sample of oven-dried sediment. Remove a small amount of water from the pycnometer and add the known mass of dried sediment to the pycnometer.

Apply a suction or boil the suspension to remove any air bubbles that may have been introduced into the pycnometer with the sediment sample. If the sample is boiled, cool the sample to the same temperature recorded for distilled water.

Weigh the pycnometer filled with the sediment suspension and record the weight to the nearest 0.1 mg.

Calculations

Calculate the specific gravity of the sediment sample as follows:

$$G_s = \frac{W_s}{W_w - W_{ws} + W_s}$$

where

G_s = specific gravity of the sample

W_s = mass of sediment used, g

W_w = mass of the water-filled pycnometer, g

W_{ws} = mass of the pycnometer filled with a water-sediment suspension, g

References

1. U. S. Geological Survey. "National Handbook of Recommended Methods for Water-Data Acquisition." U. S. Geological Survey, U. S. Department of the Interior; Reston, Virginia (1977).

INORGANIC ANALYSIS

Carbon

Organic

Inorganic

Metals

Aluminum

Cadmium

Calcium

Chromium

Copper

Iron

Lead

Magnesium

Manganese

Molybdenum

Nickel

Zinc

Arsenic

Mercury

Selenium

Nitrogen

Ammonia

Nitrate

Nitrite

Total Kjeldahl

Organic

Phosphates

Soluble Reactive

Total

Organic

Sulfides

CARBON, TOTAL ORGANIC AND INORGANIC

Carbon may exist in sediment and water samples as either inorganic or organic compounds. Inorganic carbon is present as carbonates, bicarbonates, and possibly free carbon dioxide. Specific types of compounds that are considered to be included in the organic carbon fraction are nonvolatile organic compounds (sugars), volatile organic compounds (mercaptans), partially volatile compounds (oils), and particulate carbonaceous materials (cellulose).^{1,2*}

The basis of the method is the catalytic or chemical oxidation of carbon in carbon-containing compounds to carbon dioxide followed by the quantification of the carbon dioxide produced. Alternately, the carbon may be reduced to methane and appropriately quantified. It follows, then, that the distinction between inorganic carbon and organic carbon is the method of sample pretreatment. There are presently two procedures for defining this separation. One method is based on sample treatment with a strong acid. Analysis of an untreated sample is a measure of total carbon while analysis of the acid-treated fraction is a measure of organic carbon. Inorganic carbon is calculated by subtraction. The second method of separation is based on differential thermal combustion with organic compounds being converted to carbon dioxide at 500°C to 650°C^{3,4} and inorganic carbon being converted to carbon dioxide at 950°C to 1300°C.^{4,5}

Sample Handling and Storage

Flowcharts for the handling of samples intended for organic carbon and inorganic carbon analysis are presented in Figure 3-6 and Figure 3-7. Water and sediment samples to be analyzed for inorganic carbon may be stored in glass or plastic containers. There is no effective preservative because of the carbon dioxide reserve in the atmosphere. The only precaution that can be taken for inorganic

* References for this procedure can be found on page 3-76.

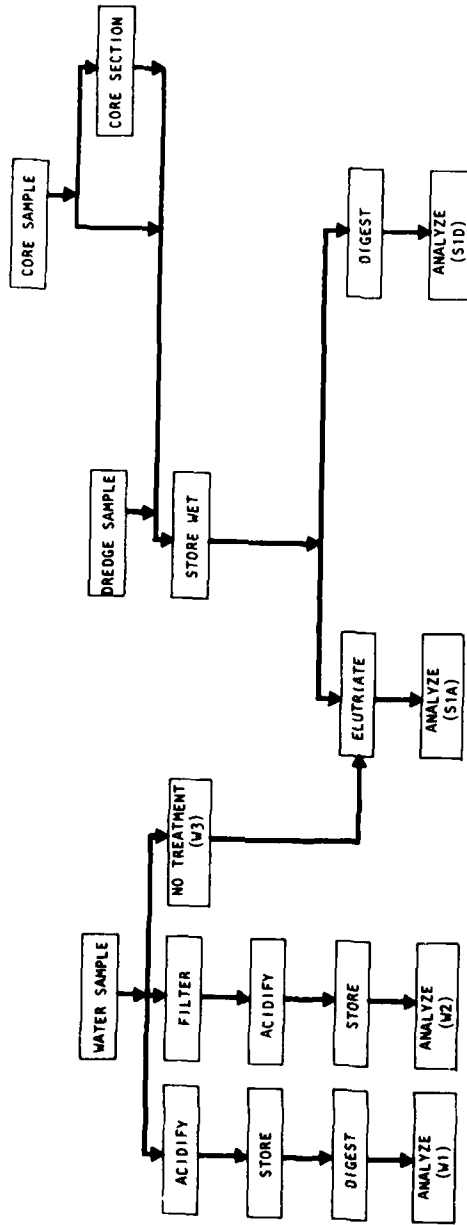

SAMPLE DESIGNATION	W1	W2	W3	S1A	S1B	S1C	S1D	S2	S3
PURPOSE	Total Water Conc.	Soluble Water Conc.	Used In Elutriate	Mobile Conc.			Total Sediment Conc.		
CONTAINER	G,P	G,P	G,P	G,P	G,P	G,P	G,P	G,P	G,P
SAMPLE TREATMENT	None	Filter	None	None	None	None	None	None	None
PRESERVATIVE	4°C (Minimize Air Contact.)	4°C (Minimize Air Contact.)	4°C	4°C (Minimize Air Contact.)	4°C	4°C	4°C	4°C	4°C
STORAGE TIME	24 hr	24 hr	-	24 hr	24 hr	24 hr	24 hr	24 hr	24 hr
DIGESTION SOLUTION									
SAMPLE VOLUME OR WEIGHT	100 ml	100 ml	-	100 ml	100 ml	100 ml	100 ml	100 ml	100 ml

Figure 3-6. Handling and storage of samples for total inorganic carbon analysis

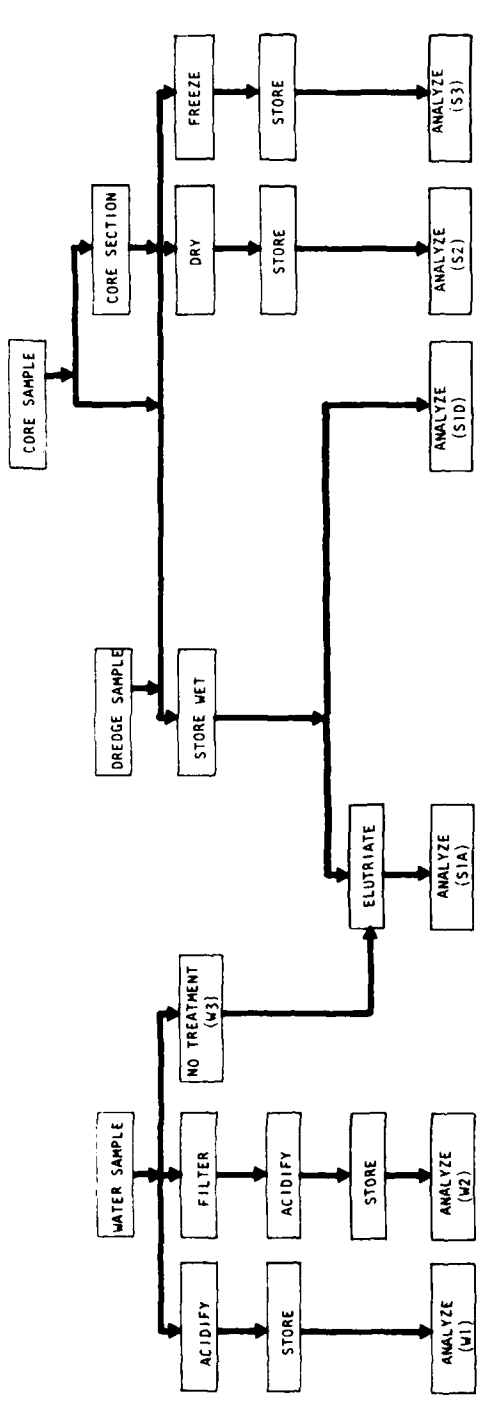

SAMPLE DESIGNATION	W1	W2	W3	S1A	S2	S3
PURPOSE	Total Water Conc.	Soluble Water Conc.	Used in Elutriate	Mobile Conc.	Total Sediment Conc.	Total Sediment Conc.
CONTAINER	G	G	G	G,P	G,P	G,P
SAMPLE TREATMENT	None	Filter	None	None	Air dry	Freeze
PRESERVATIVE	HCl or H ₂ SO ₄ to pH2 4°C	HCl or H ₂ SO ₄ to pH2 4°C	4°C	4°C	None	None
STORAGE TIME	24 hr	24 hr	<1w	<1w	-	-
SAMPLE VOLUME OR WEIGHT	30-100 ml	30-100 ml	Variable	0.5-5.0 g	0.5-5.0 g	0.5-5.0 g

Figure 3-7. Handling and storage of samples for total organic carbon analysis

carbon is to completely fill the sample container at the time of sampling (exclude all air bubbles), tightly seal the container, and complete the analysis immediately (Figure 3-6).

Water samples for organic carbon analysis should be stored in glass containers unless substitute containers have been shown not to affect total organic carbon (TOC) analyses. Samples should be processed as soon as possible (within 24 hr if possible) to minimize change due to chemical or biological oxidation. Atmospheric uptake of carbon dioxide is less critical since it would be evolved when the sample is acidified prior to analysis. Sediment samples for organic carbon analysis may be stored in either plastic or glass containers (Figure 3-7). Air drying of sediments (S2) may lead to low TOC results due to oxidation or volatilization. Therefore, moist storage (S1D) or frozen storage (S3) would be the preferred method of storage. If samples are frozen, excessive temperatures should not be used to thaw the samples.

Procedure for Water Samples (W1, W2, S1A)

Method 1: Infrared Analysis^{6,7}

Apparatus

Sample homogenizer such as a Waring blender or ultrasonic blender

Magnetic stirrer

Hypodermic syringe

Total carbon analyzer, either a single channel or a dual channel instrument (Dow-Beckman Carbonaceous Analyzer Model No. 915, Dohrmann Envirotech DC-50 carbon analyzer, Oceanography International Total Carbon Analyzer, Leco, or equivalent)

Reagents

Distilled water: the distilled water used in the preparation of standards and dilution of samples should be of the highest quality in order to have a small blank.

Organic carbon, stock solution, 1000 mg/l C: dissolve 2.125 g anhydrous potassium biphthalate, $\text{KHC}_8\text{H}_4\text{O}_4$, in distilled water and dilute to 1 l in a volumetric flask.

Organic carbon, standard solutions: prepare standard solution by dilution of the stock solution as required.

Inorganic carbon, stock solution, 1000 mg/l: dissolve 3.500 g sodium bicarbonate, NaHCO_3 , and 4.418 g sodium carbonate, Na_2CO_3 , in distilled water in a 1-l volumetric flask and make up to the mark.

Inorganic carbon, standard solution: prepare standards from the stock solution as required.

Packing for total carbon tube: dissolve 20 g cobalt nitrate, $\text{Co}(\text{NO}_3)_2 \cdot 6\text{H}_2\text{O}$, in 50 ml distilled water. Add this solution to 15 g long-fiber asbestos in a porcelain evaporating dish. Mix and evaporate to dryness on a steam bath. Place the dish in a muffle furnace and bring to 950°C. After 1 to 2 hr at this temperature, remove the dish and allow to cool. Break up any large lumps and mix adequately but not excessively. With the combustion tube held in a vertical position, taper joint up, put about 1/2 in. of untreated asbestos in the tube first, then transfer in small amounts, approximately 1 g of catalyst into the tube with forceps or tweezers. As it is added, tap or push the material gently with a 1/4-in. glass rod. Do not force the packing. The weight of the rod itself is sufficient to compress the material. When completed, the length of the packing should be about 5 or 6 cm. Test the packed tube by measuring the flow rate of

gas through it at room temperature, and then at 750°C. The rate should not drop more than 20 percent.

Packing for carbonate tube (dual channel instrument): place a small wad of quartz wool or asbestos near the exit end of the carbonate evolution tube. From the entrance end add 6 to 12 mesh quartz chips, allowing these to collect against the wad to a length of 10 cm. Pour an excess of 85 percent phosphoric acid, H_3PO_4 , into the tube while holding it vertically and allow the excess to drain out.

Nitrogen gas, carbon dioxide free.

Procedure

Turn on the infrared analyzer, recorder, and tube furnaces, setting the total carbon furnace at 950°C and the carbonate furnace at 175°C. Allow sufficient warm-up time for stable, drift-free operation; about 2 hr is required. If used daily, the analyzer can be left on continuously. Adjust the oxygen flow rate to 80 to 100 ml/min through the total carbon tube. With other instruments, follow manufacturer's directions to warm up the instrument.

Immediately prior to carrying out calibrations or analyses, inject several portions of the appropriate standard into the tube to be used, until constant readings are obtained. The actual injection technique is as follows: rinse the syringe several times with the solution to be analyzed, fill, and adjust the volume to be pipeted. Wipe off the excess with soft paper tissue, taking care that no lint adheres to the needle. Remove the clip from the syringe holder, insert the sample syringe, and inject the sample into the combustion tube with a single, quick movement of the thumb. Leave the syringe in the holder until the flow rate returns to normal, then replace it with the plug.

Periodically introduce a convenient sized aliquot (20 to 50 µl) of each standard carbon standard and a blank into the total carbon tube and record the results. Between injections allow the recorder pen to return to its baseline. When a dual channel instrument is used, the standardization procedure must be repeated using appropriate standards to calibrate the low temperature channel.

Thoroughly mix the sample. Inject a convenient sized aliquot of the sample into the total carbon tube and

record the peak height. This result is a measure of the organic carbon concentration and the inorganic carbon concentration of the sample.

Thoroughly mix the sample using a Waring blender or an ultrasonic homogenizer. Transfer 10 to 15 ml of sample to a 30-ml beaker and acidify with concentrated HCl to a pH of 2 or less. Purge the sample with carbon dioxide free nitrogen gas for 5 to 10 min. Plastic tubing should not be used during the purging process unless it has been previously shown that it will not add organic carbon to the sample.

Mix the acidified sample on a magnetic stirrer. While stirring, withdraw a subsample from the beaker using a hypodermic needle with a 150- μ m opening. Inject the sample into the carbon analyzer to be used and record the peak height. This result is a measure of the organic carbon concentration of the sample.

Using either clear or filtered water samples, analytical precision will approach 1 to 2 percent or 1 to 2 mg/l carbon, whichever is greater. Analytical precision for unfiltered water samples will increase to 5 to 10 percent because of the difficulty associated with sampling particulate matter and the fact that the needle opening of the syringe limits the maximum size of the particles that can be included in the sample.

Calculations

Dual-channel instrument. Prepare calibration curves derived from the peak heights obtained with the standard total carbon and inorganic carbon solutions.

Determine the concentration of total carbon and inorganic carbon in the sample by comparing sample peak heights with the calibration curves.

Determine the concentration of total inorganic carbon in the sample by subtracting the organic carbon value from the total carbon value.

Single-channel instrument. Prepare a calibration curve derived from the peak heights obtained with the standard total carbon solutions. Determine the total carbon concentration in the sample by comparing the peak height of the first sample injection with the

calibration curve. Determine the organic carbon concentration in the sample by comparing the peak height of the second sample injection with the calibration curve. Inorganic carbon concentrations are calculated by subtracting the organic carbon concentration from the total carbon concentration.

Procedures for Sediment Samples (S1D, S3)

Method 1: Sample Ignition

Apparatus

Induction furnace such as the Leco WR-12, Dohrmann DC-50, Coleman CH analyzer, or Perkin Elmer 240 elemental analyzer

Combustion boats

Microbalance

Desiccator

Reagents

10 percent hydrochloric acid: mix 100 ml concentrated HCl with 900 ml distilled water.

Copper oxide fines.

Benzoic acid.

Procedure

Dry at 70°C and grind the sediment sample.

Weigh a combustion boat and record the weight. Place 0.2 to 0.5 g homogenized sediment in the combustion boat and reweigh. Combustion boats should not be handled with the bare hand during this process.

If total carbon or inorganic carbon is to be determined, Cupric oxide fines may be added to the sample to assist in combustion. Combust the sample in an induction furnace. Record the result as total carbon.

If organic carbon is to be determined, treat a known weight of dried sediment with several drops of 10 percent HCl. Wait until the effervescing is completed and add more acid. Continue this process until the incremental addition of acid causes no further effervescence. Do not add too much acid at one time as this may cause loss of sample due to frothing.

Dry the sample at 70°C and place in a desiccator. Add Cupric oxide fines, combust the sample in an induction furnace, and record the result as organic carbon.

Calculations

The carbon content of the sample can be calculated as:

$$\%C = \frac{\text{weight of tube (after-before)}}{\text{sample weight}} \times 27.29$$

Derivation of factor:

$$27.29 = \frac{12.011 \text{ (molecular weight carbon)}}{44.011 \text{ (molecular weight carbon dioxide)}} \times 100\%$$

When the total sample results are used, the result is percent carbon in the sample. When acid-treated samples are used, the result is percent organic carbon. Inorganic carbon is calculated as total carbon minus organic carbon.

Method 2: Differential Combustion^{4,5}

Apparatus

Sargent programmed microcombustion apparatus or equivalent

Microbalance

Procedure

Air dry the sediment sample. Using a mortar and pestle, grind the sample to pass a 100-mesh screen.

Combust a known weight of sediment at a programmed heating rate of 300° to 950°C in 10 min and then maintain 950°C for 20 min. Trap the CO₂ in ascarite and record the weight as total carbon. A sample size should be selected that will produce 25 to 50 mg CO₂.

Weigh a second portion of the dried sediment. Combust this sample at a programmed rate of 300° to 650°C in 10 min and maintain 650°C for 20 min. Trap the CO₂ in ascarite and record the weight as organic carbon.

Calculations

The total carbon concentration, C_t, of the sample (in mg/g) is calculated as follows:

$$C_t = \frac{(X_t) \left(\frac{12}{44}\right)}{(g)}$$

where

X_t = weight of CO₂ evolved at 950°C, mg

g = weight of sample combusted, g .

The organic carbon, C_o , concentration of the sample (in mg/g) is calculated as follows:

$$C_o = \frac{(x_o) \left(\frac{12}{44}\right)}{(g)}$$

where

x_o = weight of CO_2 evolved at $650^\circ C$, mg

g = weight of sample combusted, g

Inorganic carbon, C_I , (in mg/g) is calculated as:

$$C_I = C_t - C_o$$

Method 3: Wet Combustion^{4,8}

A third method has been used for carbon in sediments. This is based on the oxidation of the sample with dichromate and back titration of the sample with ferrous ammonium sulfate. References are provided for the procedure but details are not given. The procedure is similar to the chemical oxygen demand test which is not specific for carbon. The wet combustion method is a redox procedure and any reduced chemicals in the sediment samples (ferrous iron, manganous manganese, sulfide) will react with the dichromate. Therefore, this procedure is not recommended unless other instrumentation is not available.

References

1. U. S. Environmental Protection Agency. "Manual of Methods for Chemical Analysis of Water and Wastes." Methods Development and Quality Assurance Research Laboratory, National Environmental Research Center; Cincinnati, Ohio. 298 p. (1974).
2. U. S. Environmental Protection Agency. "Methods for Chemical Analysis of Water and Wastes." Environmental Monitoring and Support Laboratory, Office of Research and Development, EPA; Cincinnati, Ohio (1979).
3. Giovannini, G., Poggio, G., and Sequi, P. "Use of an Automatic CHN Analyzer to Determine Organic and Inorganic Carbon in Soils." Unpublished Report, Laboratory of Soil Chemistry, via Corridoni, Pisa, Italy. 9 p. (1975).
4. Konrad, J. G., Chesters, G., and Keeney, D. R. "Determination of Organic- and Carbonate-Carbon in Freshwater Lake Sediments by a Microcombustion Procedure." J. Thermal Analysis 2:199-208 (1970).
5. Kemp, A. L. W. "Organic Matter in the Sediments of Lakes Ontario and Erie." Proc. 12th Conference Great Lakes Research 12:237-249 (1969).
6. Environment Canada. "Analytical Methods Manual," Inland Waters Directorate, Water Quality Branch; Ottawa, Canada (1974).
7. American Public Health Association. Standard Methods for the Examination of Water and Wastewater. APHA; New York, New York. 1193 p. (1976).
8. Gaudette, H. E., Flight, W. R., Toner, L., and Folger, D. W. "An Inexpensive Titration Method for the Determination of Organic Carbon in Recent Sediments." J. Sed. Petrology 44:249-253 (1974).

METALS

(Al, Cd, Ca, Cr, Cu, Fe, Pb, Mg, Mn, Mo, Ni, Zn)

Metals are naturally occurring elements that distribute themselves among several different chemical forms. These forms include dissolved metals, soluble metals, complexed metals, and particulate metals. The actual distribution between these forms will depend upon factors such as pH, redox potential, the presence of complexing molecules, and the specific environmental chemistry of each metal.^{1*}

Metals may reach waterways and, hence, sediments, as a result of erosion and/or weathering of geological formations. In addition, significant quantities of metals are mobilized by man as the result of mining, milling, lumbering, and similar activities.² Once in a waterway, metals are of concern because they may be essential in low concentrations to the growth of some organisms;³ they may bioaccumulate to undesirable levels in some organisms;⁴ or they may be acutely toxic at high concentrations.³ The actual impact of metals will be a function of the metal concentration, the distribution of the metal between the various chemical forms, and the sensitivity of the organisms exposed.

The most universally available instrument for the analysis of a wide spectrum of metals is an atomic absorption spectrophotometer.^{5,6} This instrument provides a method that is relatively free from spectral or radiation interferences because each metal has its own characteristic absorption wavelength. In addition, the method is more sensitive than flame photometry or most colorimetric determinations. The sensitivity of atomic absorption spectrophotometry can be further extended by graphite furnace atomization or sample concentration by chelation-extraction. Therefore, atomic absorption is the recommended method of metal analysis. Because of the similarity in the method of analysis, aluminum, cadmium, calcium, chromium, copper, iron, lead, magnesium, molybdenum, nickel, and zinc have been grouped for ease of presentation. Arsenic, mercury, and selenium are treated separately.

*References can be found on page 3-136.

Sample Handling and Storage

A generalized flowchart for the processing of water and sediment samples to be analyzed for metals is presented in Figure 3-8. The chart covers both water and sediment samples and all three chemical tests discussed earlier in the manual. The intent is to reemphasize that different methods of sample handling and pretreatment are required for each test. The selection of a specific test (bulk analysis, elutriate test, etc.) depends on the purpose of the study.

Water samples may be split into three fractions. The first (W1), consisting of the unfiltered water, can be digested as discussed later to provide a measure of the total metal concentration in the sample. The second fraction (W2) is a filtered water sample to be analyzed for soluble metal concentrations. The third fraction (W3) is an unfiltered, unpreserved water sample to be used in the elutriate test. Recommendations for sample pretreatment, preservation, and storage time are presented in Figure 3-6.

Sediment samples may be handled in three different ways although the selection of a storage method may limit the future use of the sample. For example, a sediment sample stored in a moist condition at 4°C (S1) can be used in the elutriate test, element partitioning studies, bioassays, or total analysis. However, sediment samples stored in a dried (S2) or frozen (S3) state should only be used for total or bulk analysis. Methods are presented for the digestion of sediment samples prior to analysis. The most frequently used digestion methods utilize a combination of hydrochloric acid and nitric acid since more severe treatment with hydrofluoric acid or perchloric acid requires special equipment or hoods, and other methods are less reliable or reproducible.⁶

There are other available methods such as neutron activation analysis that are specific and more sensitive than atomic absorption. However, the present limited availability of the necessary instrumentation does not justify inclusion in this version of this manual.

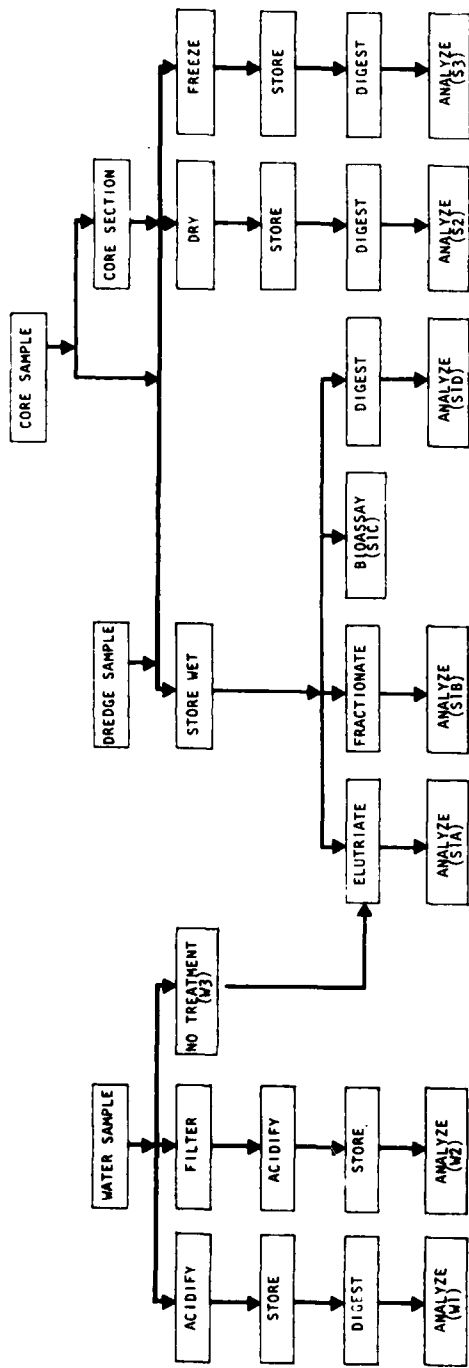

SAMPLE DESIGNATION	W1		W2	W3	S1A	S1B	S1C	S1D	S2	S3
	Total Water Conc.	Soluble Water Conc.	Used in Elutriate	Mobile Conc.	Chemical Distribution	Bioavail-ability	Total Sediment Conc.	Total Sediment Conc.	Total Sediment Conc.	Total Sediment Conc.
PURPOSE	G, P	G, P	G, P	None	None	None	None	None	Air Dry	Freeze
CONTAINER	None	Filter	None	None	None	None	None	None	None	None
SAMPLE TREATMENT	None	Filter	None	None	None	None	None	None	None	None
PRESERVATIVE	HNO ₃ pH<2	HNO ₃ pH<2	None	4°C (Minimize Air Contact. Keep Field Moist.)	4°C	4°C	4°C	4°C	None	None
STORAGE TIME	90d	90d	<1w	<1w	<1w	<1w	<1w	<1w	-	-
DIGESTION SOLUTION	Strong Acid	None	-	W3	Variable	-	Strong Acid	Strong Acid	Strong Acid	Strong Acid
SAMPLE VOLUME OR WEIGHT	100-500 ml	100-500 ml	Variable	Variable	300-500 g	Variable	2-5 g	2-5 g	2-5 g	2-5 g

Figure 3-8. Handling and storage of samples for metal analysis

Procedures for Water Samples
(All Metals Except As, Hg, and Se)

Method 1: Direct Flame Atomic Absorption, Total Metals (W1)⁵

Apparatus

Atomic absorption spectrophotometer: for samples with a high salt content, a deuterium background corrector or a double-beam instrument would be desirable

Burner: the most common type of burner, known as a premix, introduces the spray into a condensing chamber for removal of large droplets. The burner may be fitted with a conventional head containing a single 3-in.-long (7.6 cm) slot for aspirating organic solvents, a three-slot Boling head for direct aspiration of aqueous samples into an air-acetylene flame, or a head containing a single 2-in. (5 cm) slot for use with a nitrous oxide-acetylene flame

Recorder

Hollow cathode lamps: multielement lamps are available but not recommended. A separate lamp should be used for each metal to be determined

Reagents

Air: cleaned and dried through a suitable filter to remove oil, water, and other foreign substances. The source may be a compressor or commercially bottled gas.

Acetylene: standard commercial grade. Acetone, which is always present in acetylene cylinders, can be prevented from entering and damaging the burner head by replacing a cylinder when its pressure has fallen to 7 kg/cm² (100 psig) acetylene.

Nitrous oxide: commercially available cylinders.

Calcium solution: dissolve 630 mg calcium carbonate, CaCO₃, in 10 ml concentrated HCl. Add 200 ml water and, if necessary, heat the solution and boil gently to obtain complete solution. Cool and dilute to 1000 ml with deionized distilled water.

Deionized distilled water: use deionized distilled water for the preparation of all reagents and calibration standards and as dilution water.

Hydrochloric acid: HCl, concentrated.

Lanthanum solution: dissolve 58.65 g lanthanum oxide, La₂O₃, in 250 ml concentrated HCl. Add the acid slowly until the material is dissolved and dilute to 1000 ml with deionized distilled water.

Nitric acid: HNO₃, concentrated.

- Sodium chloride solution: dissolve 250 g NaCl in deionized distilled water and dilute to 1000 ml.
- Standard metal solutions: prepare a series of standard metal solutions containing 5 to 1000 $\mu\text{g}/\ell$ by appropriate dilution of the following stock metal solutions with deionized distilled water containing 1.5 ml concentrated HNO_3/ℓ .
- Aluminum: dissolve 1.000 g aluminum metal in 20 ml conc. HCl by heating gently and diluting to 1000 ml, or dissolve 17.584 g aluminum potassium sulfate (also called potassium alum), $\text{AlK}(\text{SO}_4)_2 \cdot 12 \text{H}_2\text{O}$, in 200 ml deionized distilled water, add 1.5 ml conc. HNO_3 , and dilute to 1000 ml with deionized distilled water; 1.00 ml = 1.00 mg Al.
- Calcium: to 2.4972 g calcium carbonate, CaCO_3 , add 50 ml deionized water and add dropwise a minimum volume of conc. HCl (about 10 ml) to effect complete solution. Dilute to 1000 ml with deionized distilled water; 1.00 ml = 1.00 mg Ca.
- Cadmium: dissolve 1.000 g cadmium metal in a minimum volume of 1+1 HCl. Dilute to 1000 ml with deionized distilled water; 1.00 ml = 1.00 mg Cd.
- Chromium: dissolve 2.828 g anhydrous potassium dichromate, $\text{K}_2\text{Cr}_2\text{O}_7$, in about 200 ml deionized distilled water, add 1.5 ml conc. HNO_3 , and dilute to 1000 ml with deionized distilled water; 1.00 ml = 1.00 mg Cr.
- Copper: dissolve 1.000 g iron wire in 50 ml of 1+1 HNO_3 and dilute to 1000 ml with deionized distilled water; 1.00 ml = 1.00 mg Cu.
- Iron: dissolve 1.000 g iron wire in 50 ml of 1+1 HNO_3 and dilute to 1000 ml with deionized distilled water; 1.00 ml = 1.00 mg Fe.
- Lead: dissolve 1.598 lead nitrate, $\text{Pb}(\text{NO}_3)_2$, in about 200 ml of water, add 1.5 ml conc. HNO_3 , and dilute to 1000 ml with deionized distilled water; 1.00 ml = 1.00 mg Pb.
- Magnesium: dissolve 10.0135 g magnesium sulfate heptahydrate, $\text{MgSO}_4 \cdot 7\text{H}_2\text{O}$, in 200 ml deionized distilled water, add 1.5 ml conc. HNO_3 , and make up to 1000 ml with deionized distilled water; 1.00 ml = 1.00 mg Mg.
- Manganese: dissolve 3.076 g manganous sulfate monohydrate, $\text{MnSO}_4 \cdot \text{H}_2\text{O}$, in about 200 ml deionized distilled water, add 1.5 ml conc. HNO_3 , and make up to 1000 ml with deionized distilled water; 1.00 ml = 1.00 mg Mn.
- Molybdenum: dissolve 1.840 g ammonium molybdate, $(\text{NH}_4)_6(\text{Mo}_7\text{O}_2) \cdot 4\text{H}_2\text{O}$, in deionized water and dilute to 1 ℓ .
- Nickel: dissolve 4.953 g nickelous nitrate hexahydrate, $\text{Ni}(\text{NO}_3)_2 \cdot 6\text{H}_2\text{O}$, in about 200 ml deionized distilled water, add 1.5 ml conc. HNO_3 , and make up to 1000 ml with deionized distilled water; 1.00 ml = 1.00 mg Ni.

Zinc: dissolve 1.000 g zinc metal in 20 ml 1+1 HCl and dilute to 1000 ml with deionized distilled water; 1.00 ml = 1.00 mg Zn.

Prepare dilute working solutions of each metal as required. These solutions should be prepared fresh as needed. In addition, the following steps are necessary for the preparation of working solutions of calcium, magnesium, iron, and manganese. Calcium and magnesium analyses are subject to pH effects and to interference from aluminum when analyzed by atomic absorption. These effects can be overcome by mixing 100 ml calcium and magnesium standard with 25 ml lanthanum chloride solution prior to aspiration.⁵ Atomic absorption analysis for iron and manganese is also subject to an interference that can be overcome by mixing 100 ml working standard solution with 25 ml of calcium chloride solution prior to aspiration.

Sample preparation

Transfer a 50- to 100-ml, well-mixed W1 sample to a 150-ml or larger beaker. Add 5 ml concentrated HNO₃ to the sample and evaporate to near dryness on a hot plate. Caution should be exercised during this process to ensure that the sample does not boil.

Cool the sample and add a second 5-ml portion of concentrated HNO₃. Cover the beaker with a watch glass and reflux the sample on a hot plate. Additional acid should be added to the sample as necessary during the refluxing. The heating should be continued until the digestion process is complete, as indicated by the presence of a light-colored residue.

Following digestion, add 1 to 2 ml concentrated HCl and warm the beaker slightly. Wash the watch glass and beaker walls with distilled water. Filter the digestate to remove any remaining insoluble matter and adjust the volume of the filtrate to a convenient volume with distilled water.

Analyze the sample and report results as total concentration.

Quantification procedure

Prepare a series of working metal standards by diluting the appropriate stock solutions with deionized distilled water containing 1.5 ml concentrated HNO₃/ℓ. These solutions should be prepared fresh on the day of use.

Install the appropriate hollow cathode lamp in the instrument. Align the lamp and set the source current according to the manufacturer's instructions. Turn on the instrument and allow both the instrument and lamp to warm up. This process usually requires 10 to 20 min.

Set the wavelength dial according to Table 3-9. The information in Table 3-9 should only be used as a guide in setting up the instrument. Due to calibration differences, the actual wavelength should be based on maximum sensitivity after the instrument has completely warmed up. Set the slit width according to manufacturer's instructions.

Install the burner head indicated in Table 3-9.

Turn on appropriate gases, ignite flame, and adjust the flow of fuel and oxidant to give maximum sensitivity for the metal being measured. When using a nitrous oxide flame, a T-junction valve or alternate switching valve should be employed for rapidly changing from nitrous oxide to air to prevent flashbacks when the flame is turned on or off.

Atomize deionized distilled water acidified with 1.5 ml concentrated HNO_3/ℓ and check the aspiration rate for 1 min. If necessary, adjust the aspiration rate to 3 to 5 ml/min. Zero the instrument.

Atomize a standard and adjust the burner alignment (up, down, sideways) until a maximum signal response is obtained.

Aspirate a series of metal standards that bracket the expected range of sample concentrations and record the absorbance of each standard. Rinse the atomizer with deionized distilled water containing 1.5 ml concentrated HNO_3/ℓ between each standard.

Atomize the digested water samples (W1) and determine their absorbances. Rinse the atomizer with dilute nitric acid between each sample.

Samples scheduled for iron and manganese or calcium and magnesium analysis should be premixed with calcium chloride or lanthanum chloride solution, respectively. This is accomplished by mixing four volumes of digested sample with one volume of the appropriate salt

solution.

When determining metal concentrations by atomic absorption, the following sequence of sample processing is recommended:

- a. Run a set of standards.
- b. Run five samples.
- c. Run a duplicate of the fifth sample.
- d. Run five additional samples.
- e. Run a duplicate of the fifth sample.
- f. Run a fifth sample that has been spiked.
- g. Run a standard.
- h. Repeat Steps a through f.
- i. Rerun standards.

This approach will incorporate certain aspects of the quality control program into the analytical procedure. Specifically, the suggested sequence allows for evaluation of instrument stability, replicate analysis, and spike recovery.

Calculations

Prepare a standard curve by plotting the absorbance of each standard versus concentration for each metal. Use the standard curve to convert sample absorbance to metal concentration.

Method 2: Direct Flame Atomic Absorption, Soluble Metals (W2, S1A)⁵

Apparatus

Atomic absorption spectrophotometer and appropriate burner head(s)

Recorder

Hollow cathode lamps

Reagents

Air

Acetylene

Nitrous oxide

Deionized distilled water

Concentrated hydrochloric acid

Concentrated nitric acid

Stock metal solutions as described earlier

Sample preparation

The operational definition of a soluble metal concentration is one that passes a membrane filter, usually of 0.45- μ pore-size diameter. Thus, both W2 and S1A are filtered samples. The W2 samples should be filtered at the time of collection, if possible, or as soon as practical thereafter. The S1A samples are filtered as part of the preparation of the standard elutriate.

Both of these samples may be analyzed without further treatment and the results should be reported as soluble or filtrable.

Quantification procedure

Prepare a series of working metal standards by diluting the appropriate stock solutions with deionized distilled water containing 1.5 ml concentrated HNO_3/ℓ . These solutions should be prepared fresh on the day of use.

To minimize possible matrix effects, samples should also contain 1.5 ml concentrated HNO_3/ℓ . W2 samples should routinely be preserved with HNO_3 at the time of filtration, but it will be necessary to add the appropriate volume of HNO_3 to the S1A samples.

Install the appropriate hollow cathode lamp in the instrument. Align the lamp and set the source current according to the manufacturer's instructions. Turn on the instrument and allow both the

instrument and the lamp to warm up. This process usually requires 10 to 20 min.

Set the wavelength dial according to Table 3-9. The information in Table 3-9 should only be used as a guide in setting up the instrument. Due to calibration differences, the actual wavelength should be based on maximum sensitivity after the instrument has completely warmed up. Set the slit width according to manufacturer's instructions.

Install the burner head indicated in Table 3-9.

Turn on appropriate gases, ignite flame, and adjust the flow of fuel and oxidant to give maximum sensitivity for the metal being measured. When using a nitrous oxide flame, a T-junction valve or alternate switching valve should be employed for rapidly changing from nitrous oxide to air to prevent flashbacks when the flame is turned on or off.

Atomize deionized distilled water acidified with 1.5 ml concentrated HNO_3/ℓ and check the aspiration rate for 1 min. If necessary, adjust the aspiration rate to 3 to 5 ml/min. Zero the instrument.

Atomize a standard and adjust the burner alignment (up, down, sideways) until a maximum signal response is obtained.

Aspirate a series of metal standards that bracket the expected range of sample concentrations and record the absorbance of each standard. Rinse the atomizer with deionized distilled water containing 1.5 ml concentrated HNO_3/ℓ between each standard.

Atomize the water samples (W2, S1A) and determine their absorbances. Rinse the atomizer with dilute nitric acid between each sample.

Samples scheduled for iron and manganese or calcium and magnesium analysis should be premixed with calcium chloride or lanthanum chloride reagents, respectively, as discussed earlier. This is accomplished by mixing four volumes of filtered water sample with one volume of the appropriate reagent.

When determining metal concentrations by atomic absorption,

Table 3-9
Recommended Atomic Absorption Spectrophotometer
Instrument Settings for Metal Analysis^{7, 8}

<u>Metal</u>	<u>Slit</u>	<u>Wavelength</u> <u>mu</u>	<u>Burner</u>	<u>Fuel</u>	<u>Oxidant</u>
Al	4	309.3	Nitrous oxide	Acetylene	Nitrous oxide
As		193.7			
Cd	4	228.8	Boling	Acetylene	Air
Ca	4	422.7	2-slot sideways	Acetylene	Air
Cr	4	357.9	3-slot	Acetylene	Air
Cu	4	324.7		Acetylene	Air
Fe	3	248.3	Boling	Acetylene	Air
Pb	4	283.3	Boling	Acetylene	Air
Mg	4	285.2	Nitrous oxide sideways	Acetylene	Nitrous oxide
Mn	4	279.8	Boling	Acetylene	Air
Hg	6	253.7			
Mo	4	313.5	Nitrous oxide	Acetylene	Nitrous oxide
Ni	3	232.0	Boling	Acetylene	Air
Se		196.0			
Zn	4	213.9	3-slot	Acetylene	Air

the following sequence of sample processing is recommended:

- a. Run a set of standards.
- b. Run five samples.
- c. Run a duplicate of the fifth sample.
- d. Run five additional samples.
- e. Run a duplicate of the fifth sample.
- f. Run a fifth sample that has been spiked.
- g. Run a standard.
- h. Repeat Steps a through f.
- i. Rerun standards.

In this way, the time stability of the instrument can be checked and an analytical quality control program can be incorporated into the sample processing routine.

Calculations

Prepare a standard curve by plotting the absorbance of each standard versus concentration for each metal. Use the standard curve to convert sample absorbance to metal concentration.

Method 3: Graphite Furnace Atomic Absorption^{5,8}

The use of graphite furnaces or carbon rod atomizers is considered to be an approved test method because it is essentially an atomic absorption technique.⁹ However, the method is not meant for use with all samples. The method should only be considered as an alternative to conventional flame atomic absorption spectrophotometry when one or more of the following conditions exist:¹⁰

- a. Greater analytical sensitivity is required.
- b. Sample size is limited.
- c. Samples have a high dissolved solids content and cannot be aspirated into a flame.

These conditions will usually result in the use of a graphite furnace with water samples because of the higher metal concentrations in sediments and the relative ease of increasing sediment sample size during the digestion step.

Apparatus

Atomic absorption spectrophotometer equipped with a deuterium background corrector. A double beam instrument would be considered preferable

Graphite furnace or carbon rod attachment

Automatic sampler attachment for the atomic absorption spectrophotometer or an Eppendorf pipette

Recorder

Hollow cathode lamps, a separate lamp for each metal to be determined

NOTE: The automatic sampler is the preferred method of sample transfer because it reduces analytical variability compared to other methods of sample pipetting.

Reagents

Reagents are the same as those used for conventional flame atomic absorption spectrophotometry.

Sample preparation

Graphite furnace analyses require small sample volumes. In order to avoid the problem of obtaining representative subsamples from heterogeneous samples when using small sample sizes, samples should be pretreated as discussed with Method 1. Soluble metal concentrations can be determined directly on filtered water samples (W2, S1A). Total metal concentrations can be determined with the

graphite furnace technique following strong acid digestion of the samples. Sediment digests (S1D, S2, S3) can also be analyzed with the aid of a graphite furnace but consideration should be given to digesting a larger sediment sample to achieve the desired increase in sensitivity. The digest can then be analyzed with conventional flame atomic absorption spectrophotometry.

Quantification procedure

Once a decision has been made to utilize a graphite furnace, install the attachment according to manufacturer's instructions. Align the atomizer as required and warm up the instrument. Optimum instrument conditions for the graphite furnace will generally be identical to those used for flame atomization. Check individual operation manuals for differences with specific metals (usually arsenic and selenium). Warm up the background corrector, which should always be used with the graphite furnace.

Prior to the analysis of a new series of samples or the use of a new sample cup, it is recommended that the atomizer be decontaminated. This can be accomplished by operating the instrument in the maximum temperature mode for approximately 2 sec.

The analysis is conducted by transferring a known volume of standard or sample, 5 to 20 μ l, to the sample cup. The recommended method of sample transfer would be through the use of an automatic sampler attachment. Other methods such as the use of oxford or Eppendorf pipettors can be used; but an increase in analytical variability is to be expected as a result. The sample is then subjected to a drying cycle to remove solvent, an ashing cycle to destroy organic matter, and an atomizing cycle (Table 3-10). The metal concentration is quantified during the atomization cycle. The selection of drying temperature and time, ashing temperature and time, and atomization temperature and time is critical if reproducible results are to be obtained.¹¹ Manufacturer's instructions should be followed.

Process samples in the same order suggested for conventional flame analysis: run a series of known standards to prepare a calibration curve; run five samples and duplicate the fifth sample;

Table 3-10
Graphite Furnace Operating Conditions for Selected Metals

Conditions	Al	As	Cd	Cr	Cu	Fe	Pb	Mn	Mo	Mi	Se	Zn
Drying Time, sec	30	30	30	30	30	30	30	30	30	30	30	30
Drying Temp., °C	125	125	125	125	125	125	125	125	125	125	125	125
Ashing Time, sec	30	30	30	30	30	30	30	30	30	30	30	30
Ashing Temp., °C	1300	1100	500	1000	900	1000	500	1000	1400	900	1200	400
Atomizing Time, sec	10	10	10	10	10	10	10	10	15	10	10	10
Atomizing Temp., °C	2700	2700	1900	2700	2700	2700	2700	2700	2600	2700	2700	2500
Purge Gas	Ar	Ar	Ar	Ar	Ar	Ar	Ar	Ar	Ar	Ar	Ar	Ar
Wavelength, nm	309.3	193.7	228.8	357.9	324.7	248.3	283.3	279.5	313.3	232.0	196.0	213.9

run five more samples; run a duplicate and a known spike; run a standard to check instrument stability; and repeat the cycle.

Calculations

Calculate sample concentrations by using a calibration curve to convert sample absorbance to concentration.

Method 4: Chelation-Extraction Atomic Absorption⁸

This method of quantifying metals is another version of atomic absorption spectrophotometry. The advantage of this method is the increased sensitivity that is obtained by chelating metals with an organic ligand and concentrating the metal complexes into an organic solvent. This approach offers the advantages of concentrating the sample (by the ratio of the initial sample volume to the volume of organic solvent) and removing the metal from any interfering substances in the original sample. However, the sample pH can affect extraction efficiency^{7,10} and the extracted metal complex is time dependent.⁷ Thus, the extracts should be processed promptly. In addition, the metals must be analyzed in a specific order with the least stable metal complexes being analyzed first and the most stable metal complexes being analyzed last.

Apparatus

pH meter

Shaker, mechanical, and holders for 250-ml volumetric flasks

Glassware: all glassware such as Erlenmeyer flasks, beakers, pipettes, volumetric flasks, and funnels should be rinsed with 1:1 nitric acid and rinsed with deionized water

Atomic absorption spectrophotometer, equipped with appropriate burner(s)

Recorder

Reagents

Ammonium pyrrolidine dithiocarbamate (APDC) solution, 1 percent: dissolve 1 g APDC in 100 ml deionized water and filter, if necessary. Prepare fresh before use.

Methyl isobutyl ketone (MIBK).

Buffer (pH 4.75) solution: dissolve 272 g sodium acetate, CH_3COONa , in distilled water and dilute to about 1 l in a 2-l beaker. Add acetic acid, CH_3COOH , to the solution until a pH of 4.75 is reached (use a pH meter). Dilute to 2 l. Extract this solution with 0.01 percent dithizone until the extract remains green; then extract with carbon tetrachloride, CCl_4 , to remove excess dithizone.

Dithizone, 0.01 percent: dissolve 0.01 g of diphenylthiocarbazone in 100 ml carbon tetrachloride.

Stock metals solutions, prepare as described earlier.

Sample preparation

Pipette a 100-ml volume of sample digest (W1, W2, S1A) into a 250-ml volumetric flask. If more sensitivity is desired, a larger sample size can be used. However, the size of the flask and the volume of subsequent reagents should be increased proportionately.

Prepare a blank and sufficient standards to cover the expected concentration range of the samples.

Add 5.0 ml buffer to each and mix by swirling flasks. Adjust the pH in the range of 2 to 3 using either bromphenol blue or a pH meter.

Add 5.0 ml APDC to each and mix by swirling flasks.

Add 10.0 ml MIBK and shake the flasks for 5 min on a mechanical shaker equipped with special holders for the flasks.

Allow the solvent layers to separate. In order to raise the MIBK layer to the neck of the flask, slowly add deionized water down the side of the flask. This will reduce the number of sample transfers and the amount of glassware required. However, it is essential that the water be added very carefully as physical disturbance of the organic layer could reduce the extraction efficiency.

It is imperative to point out that the stability of the extracted APDC-metal complexes is time dependent and generally on the order of a few hours. Therefore, it is necessary that sample analysis commence immediately after extraction.

Quantification procedure

Install the appropriate hollow cathode lamp in the instrument. Align the lamps and set the source current according to the manufacturer's instructions. Turn on the instrument and allow both the instrument and lamps to warm up. This process usually requires 10 to 20 min. If possible, this process should be started before the extractions are completed because of the limited stability of the metal extracts.

Install a single slot burner designed for use with organic solvents. Turn on the appropriate fuel and oxidant gases and adjust the flows to give maximum sensitivity for the metal being

measured. In setting the fuel-to-air ratio of the gas mixture at the burner, start with the settings recommended by the manufacturer for the analysis (Table 3-9). Note the color of the flame and begin aspiration of MIBK solvent. Gradually reduce the flow of the fuel while continuing to aspirate the solvent until the color of the flame is similar to that noted earlier. This step is necessary because the organic solvent contributes to the fuel supply. If this precaution is not taken, the resultant flame may produce an undesirable luminescence or be lifted off the burner. With the nitrous oxide burner, approximately double the flow of acetylene is required over that normally used for the air acetylene burner; the acetylene should be adjusted until the flame is a rose-red color.

NOTE: When using a nitrous oxide flame, a T-junction valve or alternate switching valve should be employed for rapidly changing from nitrous oxide to air to prevent flashbacks when the flame is turned on or off.

Atomize the organic solvent and check the aspiration rate for 1 min. If necessary, adjust the aspiration rate to 3 to 5 ml/min. Zero the instrument. Atomize a standard and adjust the burner alignment until a maximum signal response is obtained.

Aspirate the extracted metal standards and record the absorbance of each standard. Rinse the burner with organic solvent between each standard.

Aspirate the solvent layer from each of the extracted samples. Record the sample absorbance. Continue to rinse the burner with organic solvent between each sample.

The sequence of sample processing should consist of a set of standards, five samples, a duplicate sample, a standard, five samples, a duplicate sample, and a spiked sample. Repeat the sequence until all samples have been processed.

Calculations

Prepare a calibration curve derived from the peak heights obtained with the standard solutions. Determine the concentration of metal in the sample by comparing sample peak height with the calibration curve.

Procedure for Sediment Samples
(All Metals Except As, Hg, and Se)

Method 1: Direct Flame Atomic Absorption, Total Metals
(S1D, S2, S3)^{5,11}

Apparatus

Atomic absorption spectrophotometer with appropriate burner head(s)
Recorder
Hollow cathode lamps
Balance
Digestion apparatus (hot plate, Kjeldahl digestion unit, muffle furnace, or digestion bomb)

Reagents

Air
Acetylene
Nitrous oxide
Deionized distilled water
Stock metal solutions, as described earlier
Digestion reagents, as specified with each digestion procedure

Sample preparation

Each of the designated fractions, S1D, S2, and S3, listed with this procedure is intended for strong acid digestion and total metal analysis. The only difference between these samples is the method of handling prior to digestion: one sample is stored moist and has a shorter recommended storage period (S1D); one sample has been previously air dried (S2); and the third sample has been stored frozen (S3). The selection of a sample storage method is left up to each laboratory although the use of moist samples (S1D) is recommended because the same sediment could be used in the elutriate test, elemental partitioning, and bioassay studies, if necessary.¹²

Depending on the method of sample storage, proceed with the appropriate procedure:

- a. Starting with moist sediment samples (S1D), determine the percent solids in the samples. Accurately weigh a 0.5- to 1.0-g dry weight equivalent aliquot of the

sample using an analytical balance. The sample weight should be selected based on the anticipated metal concentrations and the detection limit and/or the upper concentration range of the analytical technique to be used.

- b. Starting with dried sediment samples (S2), accurately weigh a 0.5- to 1.0-g aliquot of the sample using an analytical balance. The sample weight should be selected based on the anticipated metal concentrations and the detection limit and/or the upper concentration range of the analytical technique to be used.
- c. Starting with a frozen sediment sample (S3), thaw the samples at room temperature. Determine the percent solids in the samples. Accurately weigh a 0.5- to 1.0-g dry weight equivalent aliquot of the sample using an analytical balance. The sample weight should be selected based on the anticipated metal concentrations and the detection limit and/or the upper concentration range of the analytical technique to be used.

Proceed with one of the digestion techniques provided in Tables 3-1 through 3-17. Treatment with hydrofluoric acid and perchloric acid (Table 3-16) or treatment with hydrofluoric acid-nitric acid-hydrochloric acid (Table 3-17) are the most severe of the listed procedures and regarded as yielding the most complete digestion. However, these procedures should only be used with appropriate hoods and safety equipment. Combinations of nitric acid and hydrochloric acid (Table 3-11) have been proven to be effective digestion solutions for routine use and do not require special hoods or glassware.

The procedures summarized in Tables 3-11 through 3-15 were evaluated to determine their ability to solubilize 13 metals (As, Cd, Cr, Cu, Pb, Ni, Ca, Mg, Na, K, Fe, Mn, and Zn) from a municipal treatment plant sludge.⁶ Based on calculated 95 percent confidence limits, the HNO₃-HCl digestion procedure in Table 3-10 provided equivalent recoveries for all metals. The HNO₃ digestion procedure (Table 3-12) was comparable to the HNO₃-HCl digestion procedure for all metals except Ni. Low As and Ca results were observed with HNO₃-H₂O₂ treatment (Table 3-13). The least satisfactory results were observed with muffle furnace ignition (Table 3-14) and low temperature ashing (Table 3-15). Muffle furnace ignition produced low results for

Table 3-11
HNO₃-HCl Digestion^{6,13}

<u>Step</u>	<u>Procedure</u>
1.	Prepare HNO ₃ -HCl (1:3 v/v) digestion mixture (aqua regia) just prior to each use by carefully adding, with stirring, one volume conc. HNO ₃ to three volumes of conc. HCl. A convenient batch volume is a 30 ml conc. HNO ₃ and 90 ml conc. HCl. CAUTION: Avoid inhaling fumes.
2.	Accurately weigh a 0.05- to 1.0-g dried sludge sample, using an analytical balance. Select the sample weight based on anticipated metal concentrations and the detection limit/upper concentration range of the atomic absorption spectrophotometer calibration curves.
3.	Place dried sludge in an Erlenmeyer flask (125 or 250 ml volume). Alternatively, a 250-ml beaker with watch glass may be used.
4.	Moisten dried sludge with ca. 0.5 to 1.0 ml deionized distilled water (DDW).
5.	Slowly add 10 ml HNO ₃ -HCl and swirl container to control effervescence and to ensure good mixing.
6.	Place container on hot plate. Bring to slow boil. Continue boiling until solution approaches dryness.
7.	Carefully add more HNO ₃ -HCl in 5-ml increments and repeat Step 5 until all visible organic matter is destroyed and the solution begins to clear.
8.	Continue boiling until the evolution of reddish-brown fumes ceases.
9.	Remove container from hot plate, cool to room temperature, add ca. 20 ml DDW, and separate the digestate from any mineral residue, if present, by filtering through a Whatman No. 42 or equivalent filter paper or a 0.4- μ m membrane filter.
10.	Rinse container and filter paper with ca. 5 to 10 ml DDW two times and collect rinses. Quantitatively transfer and combine rinses and filtrate into a volumetric flask (50 or 100 ml volume) and dilute with DDW to the volume mark.

(Continued)

Table 3-11 (Concluded)

Step	Procedure
11.	Dilute the solution from Step 10 further, if necessary. Analyze metal(s) by atomic absorption spectrophotometry according to the instrument manufacturer's operating instructions. Calculate and report the concentration of metal(s) in the sludge sample on a mg/kg dry weight basis.

Table 3-12
HNO₃ Digestion⁶

<u>Step</u>	<u>Procedure</u>
1.	Place dried sludge in an Erlenmeyer flask (125 or 250 ml volume). Alternatively, a 250-ml beaker with watch glass may be used.
2.	Moisten dried sludge with ca. 0.5 to 1.0 ml deionized distilled water (DDW).
3.	Slowly add 10 ml conc. HNO ₃ and swirl container to control effervescence and to ensure good mixing.
4.	Place container on hot plate. Bring to slow boil. Continue boiling until the solution approaches dryness.
5.	Carefully add more conc. HNO ₃ in 5-ml increments and repeat Step 5 until all visible organic matter is destroyed and the solution begins to clear.
6.	Continue boiling until the evolution of reddish-brown fumes ceases.
7.	Remove container from hot plate, cool to room temperature, add ca. 20 ml DDW, and separate the digestate from any mineral residue, if present, by filtering through a Whatman No. 42 or equivalent filter paper or a 0.4- μ membrane filter. Collect filtrate.
8.	Rinse container and filter paper with ca. 5 to 10 ml DDW two times and collect rinses. Quantitatively transfer and combine rinses and filtrate into a volumetric flask (50 or 100 ml volume) and dilute with DDW to the volume mark.
9.	Dilute the solution from Step 9 further, if necessary. Analyze metal(s) by atomic absorption spectrophotometry according to the instrument manufacturer's operating instructions. Calculate and report the concentration of metal(s) in the sludge sample on a mg/kg dry weight basis.

Table 3-13
HNO₃-H₂O₂ Digestion⁶

<u>Step</u>	<u>Procedure</u>
1.	Place dried sludge in an Erlenmeyer flask (125 or 250 ml volume). Alternatively, a 250-ml beaker with watch glass may be used.
2.	Moisten dried sludge with ca. 0.5 to 1.0 ml deionized distilled water (DDW).
3.	Slowly add 10 ml conc. HNO ₃ and swirl container to control effervescence and to ensure good mixing.
4.	Place container on hot plate. Bring to slow boil. Continue boiling until the solution approaches dryness.
5.	Carefully add more conc. HNO ₃ in 5-ml increments and repeat Step 4 until all visible organic matter is destroyed and the solution begins to clear.
6.	Continue boiling until the evolution of reddish-brown fumes ceases.
7.	Remove container from the hot plate and cool to ca. room temperature.
8.	Add 3 ml conc. HNO ₃ and 10 ml 30 percent H ₂ O ₂ . Return container to the hot plate and warm gently. Using tongs, alternatively remove the container from the hot plate to allow any effervescence to subside and then rewarm. Continue this process until subsequent warming does not produce any further effervescence.
9.	Heat the solution to boiling and continue heating for at least 15 min.
10.	Remove container from hot plate, cool to room temperature, add ca. 20 ml DDW, and separate the digestate from any mineral residue, if present, by filtering through a Whatman No. 42 or equivalent filter paper or a 0.45-μ membrane filter. Collect

(Continued)

Table 3-13 (Concluded)

Step	Procedure
10.	filtrate.
11.	Rinse container and filter paper with ca. 5 to 10 ml DDW two times and collect rinses. Quantitatively transfer and combine rinses and filtrate into a volumetric flask (50 or 100 ml volume) and dilute with DDW to the volume mark.
12.	Dilute the solution from Step 11 further, if necessary. Analyze metal(s) by atomic absorption spectrophotometry according to the instrument manufacturer's operating instructions. Calculate and report the concentration of metal(s) in the sludge sample on a mg/kg dry weight basis.

Table 3-14
Muffle Furnace Ignition⁶

<u>Step</u>	<u>Procedure</u>
1.	Place the Pt crucible containing the dried sludge sample into a room temperature muffle furnace. Bring the furnace to 550°C and maintain the temperature for ca. 30 min.
2.	Remove the Pt crucible from the muffle furnace, cool for 5 to 10 min, place in a desiccator, and cool to room temperature. Reweigh the crucible, if desired, to determine the amount of volatile matter lost on ignition.
3.	Add a small volume (1 to 3 ml) of warm conc. HNO ₃ to the residue in the Pt crucible and place on a hot plate. Heat the crucible (avoid splattering and do not boil) until most of the acid has evaporated. Do not heat to dryness.
4.	Remove container from hot plate, cool to room temperature, add ca. 20 ml DDW, and separate the digestate from any mineral residue, if present, by filtering through a Whatman No. 42 or equivalent filter paper or a 0.4-μ membrane filter. Collect filtrate.
5.	Rinse container and filter paper with ca. 5 to 10 ml DDW two times and collect rinses. Quantitatively transfer and combine rinses and filtrate into a volumetric flask (50 or 100 ml volume) and dilute with DDW to the volume mark.
6.	Dilute the solution from Step 5 further, if necessary. Analyze metal(s) by atomic absorption spectrophotometry according to the instrument manufacturer's operating instructions. Calculate and report the concentration of metal(s) in the sludge sample on a mg/kg dry weight basis.

Table 3-15
Low Temperature Ashing⁶

<u>Step</u>	<u>Procedure</u>
1.	Place the Petri dish containing the dried sludge sample into the low temperature ashing instrument cavity and operate according to the instruction manual. A flat quartz plate can be installed in cylindrical cavities for ease of sample placement. Experience showed that three successive 8-hr ashing cycles at 200 watts (RF) were necessary to completely ash the sludge sample.
2.	Upon completion of the ashing step, dissolve the residue with a small volume (ca. 1 to 3 ml) of conc. HNO ₃ and quantitatively transfer the solution to a filtration apparatus, if necessary.
3.	Rinse container and filter paper with ca. 5 to 10 ml DDW two times and collect rinses. Quantitatively transfer and combine rinses and filtrate into a volumetric flask (50 or 100 ml volume) and dilute with DDW to the volume mark.
4.	Dilute the solution from Step 3 further, if necessary. Analyze metal(s) by atomic absorption spectrophotometry according to the instrument manufacturer's operating instructions. Calculate and report the concentration of metal(s) in the sludge sample on a mg/kg dry weight basis.

Table 3-16
HF-HClO₄-HNO₃ Digestion¹⁴

<u>Step</u>	<u>Procedure</u>
1.	Accurately weigh a 0.5- to 1.0-g dry weight equivalent of the homogenized sample using an analytical balance. Transfer the sample to a 50-ml polypropylene beaker.
2.	Add 5 ml 48 percent hydrofluoric acid (HF) and heat on a steam bath at about 100°C to dryness (8 to 12 hr).
3.	Transfer residue to a 100-ml Kjeldahl flask. Add 10 ml digestion solution (5 parts conc. HNO ₃ and 3 parts 60 percent HClO ₄). Heat on an Aminco (American Instrument Company) micro Kjeldahl unit until the evolution of HClO ₄ fumes. This step should be performed in an appropriate fume hood and a trap should be established to catch the HClO ₄ fumes.
4.	Add 5 ml conc. HCl and heat for 1 hr.
5.	Cool the sample. Dilute to approximately 30 ml with distilled water.
6.	Filter to remove any solid residue and dilute to 100 ml or some other convenient volume with distilled water. Analyze by the method of choice.

Table 3-17
HF-HNO₃-HCl Digestion^{8,14}

Step	Procedure
1.	Accurately weigh 0.1- to 0.5-g dry weight equivalent of homogenized sediment using an analytical balance. Transfer to a PTFE bomb (Pan 4745 acid-digestion bomb or equivalent; Pan Instrument Company; Moline, Illinois).
2.	Add 6 ml 48 percent HF and 1 ml aqua regia (3:1 HCl:HNO ₃). Seal the bomb and heat at 110°C for 2 hr.
3.	Cool the samples and transfer to a 125-ml polypropylene wide-mouthed bottle containing 4.8 g boric acid.
4.	The digestate can be analyzed for metals except mercury by transferring to a volumetric flask, adding 10 ml hydroxylammonium sulfate-6 percent m/v sodium chloride), and diluting to volume. Analyze by method of choice.
5.	To analyze the digestate for mercury, cool the sample bomb in an ice-water bath. Carefully add 10 ml 6 percent m/v potassium permanganate and let stand 30 min.
6.	Add 5 ml 5 percent potassium persulfate and allow samples to digest overnight at room temperature.
7.	Transfer to a volumetric flask. Add 10 ml hydroxylammonium sulfate-sodium chloride solution (6 percent m/v hydroxylammonium sulfate-6 percent m/v sodium chloride) and dilute to volume. Analyze by method of choice.

Cr, Ni, Mg, and Fe; while low temperature ashing produced low results for As, Ni, Mg, and K. Based on the above study, the recommended digestion technique would be the HNO₃-HCl procedure (Table 3-11). The HNO₃ procedure (Table 3-12) or the HNO₃-H₂O₂ procedure (Table 3-13) would be a good second choice.

The user is cautioned that no single digestion method may be appropriate for all samples. Rosengrant¹⁵ observed generally better recoveries using 1:4 HCl:HNO₃ rather than 1:1 HCl:HNO₃ but did not use the 3:1 HCl:HNO₃ specified by Delfino and Enderson.⁶ Other factors¹⁵ that may contribute to variable results during the digestion procedure are (1) the length of digestion period, (2) the specific metal of interest, and (3) the type of sediment. Longer digestion times favor more complete metal recovery and times of 6¹⁶ and 24¹⁵ hr have been found to be convenient and useful. Metals that have been shown to yield variable results are Cr, Ni, Fe, and Mn.¹⁵ Available data also suggest that physical factors such as sample particle size or mineral composition can affect the efficiency of a digestion procedure.^{15,17}

The technical literature indicates that the most commonly used and reproducible digestion procedure is a variation of the HCl-HNO₃ digestion technique.^{6,14-17} However, if there are problems with reproducibility (overall precision of \pm 10 percent or better should be attainable^{6,15}), metal recovery, or sample composition, there are more severe digestion techniques available. These procedures involve the use of hydrofluoric acid and/or perchloric acid. Hydrofluoric acid is useful to break down silicate matrices and perchloric acid is useful for decomposing organic matter. Variations of the HF and HClO₄ digestion procedures are presented in Tables 3-16 and 3-17. Unfortunately, these acids can be highly corrosive and potentially explosive and their use is not recommended unless appropriate safety equipment is in use in the laboratory.

Quantification procedure

Prepare the standards in an appropriate acid medium (depending on the digestion procedure used) or carry standards

through the digestion procedure. These solutions should be prepared fresh on the day of use.

Install the appropriate hollow cathode lamp in the instrument. Align the lamp and set the source current according to the manufacturer's instructions. Turn on the instrument and allow both the instrument and the lamp to warm up. This process usually requires 10 to 20 min.

Set the wavelength dial according to Table 3-9. The information in Table 3-9 should only be used as a guide in setting up the instrument. Due to calibration differences, the actual wavelength should be based on maximum sensitivity after the instrument has completely warmed up. Set the slit width according to manufacturer's instructions.

Install the burner head indicated in Table 3-9.

Turn on appropriate gases, ignite flame, and adjust the flow of fuel and oxidant to give maximum sensitivity for the metal being measured. When using a nitrous oxide flame, a T-junction valve or alternate switching valve should be employed for rapidly changing from nitrous oxide to air to prevent flashbacks when the flame is turned on or off.

Atomize distilled water acidified with 1.5 ml concentrated HNO_3/ℓ and check the aspiration rate for 1 min. If necessary, adjust the aspiration rate to 3 to 5 ml/min. Zero the instrument.

Atomize a standard and adjust the burner alignment (up, down, sideways) until a maximum signal response is obtained.

Aspirate a series of metal standards and record the absorbance. Rinse the atomizer between each standard with the same acidified solution used to zero the instrument.

Atomize the digested sediment samples (S1D, S2, S3) and determine their absorbances. Rinse the atomizer with dilute nitric acid between each sample.

When determining metal concentrations by atomic absorption, the following sequence of sample processing is recommended:

- a. Run a set of standards.

- I**
- b. Run five samples.
 - c. Run a duplicate of the fifth sample.
 - d. Run five additional samples.
 - e. Run a duplicate of the fifth sample.
 - f. Run a fifth sample that has been spiked.
 - g. Run a standard.
 - h. Repeat Steps a through f.
 - i. Rerun standards.

This sequence will incorporate a quality control program into the sample processing routine and allow the instrument operator to check for instrument stability.

Calculations

Prepare a standard curve by plotting the absorbance of each standard versus concentration for each metal. Use the standard curve to convert sample absorbance to metal concentration.

METALS
(Arsenic)

Arsenic is determined using a variation of the atomic absorption technique. One method consists of reduction of the arsenic in a sample followed by quantification of evolved arsine. This offers the advantage of minimizing matrix interference effects during analysis but should be used cautiously because of the potential hazard associated with arsine. The second available method for arsenic is the graphite furnace variation.

Sample Handling and Storage

Arsenic samples can be handled in the same manner as most metal samples. Either glass or plastic containers are acceptable and sample integrity can be maintained up to 6 mo with the use of nitric acid (Figure 3-8).

Procedures for Water Samples (W1, W2, S1A)

Method 1: Arsine Generation^{5,6}

Apparatus

Arsine generator as shown in Figure 3-9. This will include:

- a. Flow meter capable of measuring 1 l/min.
- b. Medicine dropper capable of delivering 1.5 ml and fitted into a size "0" rubber stopper.
- c. Reaction flask, which is a pear-shaped vessel with a side arm and a 50-ml capacity. Both arms should have a 1 $\frac{1}{2}$ /20 ground glass joint.
- d. Special gas inlet-outlet tube constructed from a micro cold finger condenser with the portion below the ground glass joint cut off. A Scientific Glass JM-3325 condenser or equivalent is suitable.
- e. Drying tube consisting of a 100-mm-long polyethylene tube filled with glass wool.

Magnetic stirrer

References for this procedure are found on page 3-136.

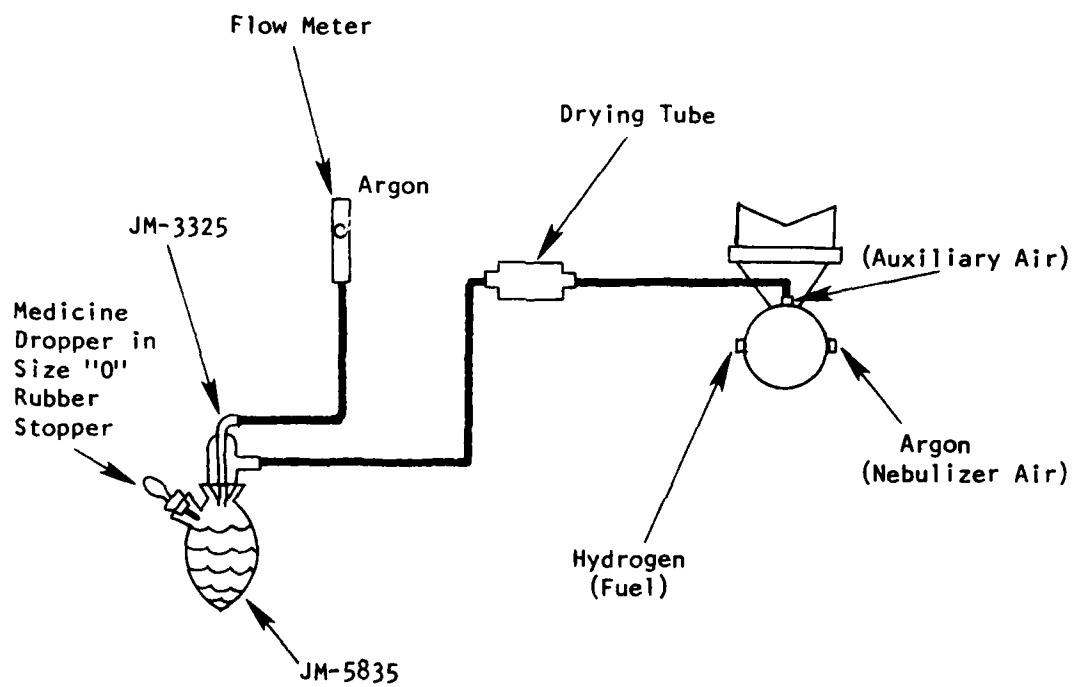

Figure 3-9. Arsine generator for arsenic and selenium analysis

Atomic absorption spectrophotometer

Arsenic hollow cathode lamp

Reagents

Potassium iodide: dissolve 20 g KI in 100 ml deionized distilled water. Prepare fresh daily.

Stannous chloride solution: dissolve 100 g SnCl₂ in 100 ml concentrated hydrochloric acid.

Zinc slurry: add 50 g 200 mesh zinc metal dust to 100 ml deionized distilled water.

Standard diluent: add 100 ml 18 N H₂SO₄ and 400 ml concentrated HCl to 400 ml deionized distilled water in a 1-l flask and dilute to volume with deionized distilled water.

Perchloric acid, 70 to 72 percent.

Concentrated hydrochloric acid.

Concentrated nitric acid.

18 N sulfuric acid: dilute 500 ml sulfuric acid to 1 l with deionized distilled water.

Stock arsenic solution: dissolve 1.3209 g arsenic trioxide, As₂O₃, in 100 ml distilled water containing 4 g NaOH and dilute to 1 l with deionized distilled water. 1.00 ml = 1.00 mg As.

Intermediate arsenic solution: pipet 1 ml stock arsenic solution into a 100-ml volumetric flask and dilute to volume with deionized distilled water containing 1.5 ml concentrated HNO₃/l. 1.00 ml = 10 µg As.

Working arsenic solution: pipet 10 ml intermediate arsenic solution into a 100-ml volumetric flask and dilute to volume with deionized distilled water containing 1.5 ml concentrated HNO₃/l. 1.00 ml = 1 µg As.

Procedure

Treat the sample with hydrochloric acid to determine inorganic arsenic (a) or nitric and sulfuric acid to determine total arsenic (b):

Inorganic Arsenic

- a. Pipet 25-ml W1, W2, or S1A sample into a 50-ml volumetric flask. Add 20 ml concentrated hydrochloric acid and dilute to volume with deionized distilled water.

Total Arsenic

- b. (1) Pipet a 50-ml W1, W2, or S1A sample into a 150-ml beaker. Add 10 ml concentrated nitric acid and 12 ml 18 N sulfuric acid.
- (2) Evaporate the sample to the evolution of SO₃ fumes (approximately 20 ml). To avoid the loss of arsenic, add small amounts of nitric acid whenever the red-brown NO₂ fumes disappear.
- (3) Cool slightly, add 25 ml deionized distilled water and 1 ml perchloric acid, and evaporate to SO₃ fumes. Cool, add 40 ml concentrated hydrochloric acid, and dilute to a volume of 100 ml with deionized distilled water.

Prepare standard arsenic solutions by diluting 0, 0.5, 1.0, 1.5, and 2.0 ml of working arsenic solution to 100 ml with the standard acid diluent. These solutions contain 0, 5, 10, 15, and 20 µg As/l.

Pipet 25 ml of the sample [either (a) or (b)] or standard arsenic solution into the reaction vessel. Add 1.0 ml KI solution and 0.5 ml SnCl₂ solution. Allow 10 min for the arsenic to be reduced to the lowest oxidation state.

Attach the reaction vessel to the special gas inlet-outlet glassware. Fill the medicine dropper with 1.50 ml homogenized zinc slurry and insert the medicine dropper in the side neck of the reaction vessel. With the arsine generator attached to the atomic absorption spectrophotometer using an argon-hydrogen flame, add the zinc slurry to the sample. The arsine peak should occur almost immediately. When the recorder pen returns part way to the baseline, remove the reaction vessel.

Calculations

Prepare a standard curve by plotting peak height versus arsenic concentration in the standards. Determine the arsenic concentration by comparing sample peak height with the standard curve.

It is necessary to multiply the determined sample arsenic concentrations by a factor of 2 to correct for the fact that samples were diluted by 50 percent with acid and the standards were not.

Report results with W1 samples as total arsenic and results with W2 and S1A samples as soluble arsenic.

If it is necessary or desirable to determine organic arsenic, this can be calculated as total arsenic (digestion b) minus inorganic arsenic (digestion a).

Method 2: Graphite Furnace¹⁰

Apparatus

Atomic absorption spectrophotometer equipped with a graphite furnace or carbon rod atomizer and background corrector

Recorder

Automatic sampler or Eppendorf pipettes

Hot plate or hot water bath

Reagents

Stock solution: dissolve 1.320 g of arsenic trioxide, As_2O_3 (analytical reagent grade), in 100 ml of deionized distilled water containing 4 g NaOH. Acidify the solution with 20 ml conc. HNO_3 and dilute to 1 l. 1 ml = 1 mg As.

Working arsenic solution: prepare dilutions of the stock solution to be used as calibration standards at the time of analysis. Withdraw appropriate aliquots of the stock solution and add 1 ml of concentrated HNO_3 , 2 ml of 30 percent H_2O_2 , and 2 ml of the 5 percent nickel nitrate solution. Dilute to 100 ml with deionized distilled water.

Nickel nitrate solution, 5 percent: dissolve 24.780 g of ACS reagent grade $Ni(NO_3)_2 \cdot 6H_2O$ in deionized distilled water and make up to 100 ml.

Nickel nitrate solution, 1 percent: dilute 20 ml of the 5 percent nickel nitrate to 100 ml with deionized distilled water.

Procedure

Transfer a 100-ml W1, W2, or S1A sample to a 250-ml Griffin beaker. Add 2 ml 30 percent H_2O_2 and sufficient concentrated HNO_3 to produce a 1 percent (v/v) acid concentration (approximately 1 ml). Heat for 1 hr at 95°C or until the volume is slightly less than 50 ml.

Cool and dilute the sample to 50 ml with deionized distilled water.

Pipet 5 ml of digested sample to a 10-ml volumetric

flask. Add 1 ml of 1 percent nickel nitrate solution and dilute to 10 ml with deionized distilled water.

Inject 20- μ l aliquots of standard and digested samples. Record the sample absorbance. The method of standard additions should be used to quantitate the sample unless it can be shown that the sample matrix does not affect the results.¹⁰

Calculations

Prepare a standard curve by plotting absorbance of the arsenic standards versus arsenic concentration. Determine the arsenic concentration of the samples by comparing the observed absorbance with the standard curve.

Procedure for Sediment Samples (S1D, S2, S3)

Method 1: Arsine Generation¹¹

Apparatus

Atomic absorption spectrophotometer

Arsine generator as shown in Figure 3-9 and described in the procedure for the analysis of arsenic in water samples. Use a 5-ml medicine dropper rather than a 1.5-ml medicine dropper

Reagents

Concentrated hydrochloric acid.

Potassium iodide: dissolve 15 g in 100 ml distilled deionized water. Prepare daily.

Stannous chloride: dissolve 40 g SnCl_2 in 100 ml concentrated hydrochloric acid.

Zinc slurry: add 50 g 200 mesh zinc metal dust to 100 ml deionized distilled water.

Stock arsenic solution: dissolve 1.320 g arsenic trioxide, As_2O_3 , in 10 ml deionized distilled water containing 4 g NaOH. Dilute it to 1 l with deionized distilled water. 1.00 ml = 1.00 mg As.

Intermediate arsenic solution: pipet 1 ml stock arsenic solution into a 100-ml volumetric flask and dilute to volume with deionized distilled water containing 1.5 ml concentrated HNO_3/ℓ . 1.00 ml = 10 μg As. Prepare arsenic standards daily in the appropriate range.

Procedure

Weigh out 0.5 g dry weight equivalent of the sediment sample (S1D, S2, S3). Transfer to a 100-ml beaker and add 2.5 g potassium pyrosulfate. If larger sediment samples are used, proportionately increase the amount of potassium pyrosulfate used.

Fuse the sample at 320°C for 15 min in a furnace. Cool the sample.

Dissolve the residue in 25 ml deionized distilled water and 5 ml concentrated hydrochloric acid. Heat the sample in a water bath, if necessary, to dissolve the solids.

Transfer the sample to a 100-ml volumetric flask and dilute to volume with deionized distilled water.

Pipette 25 ml of sample or standard to the reaction vessel in Figure 3-8. Add 5 ml concentrated hydrochloric acid and

mix thoroughly. Add 2 ml potassium iodide solution and mix thoroughly. Add 0.5 ml stannous chloride and allow 30 min for the reduction of arsenic.

Attach the reaction vessel to the special glass inlet-outlet tube of the arsenic generator attached to the atomic absorption spectrophotometer.

While stirring the zinc slurry, fill the medicine dropper with 5 ml of zinc slurry. Insert the medicine dropper into the side neck of the reaction vessel. When the instrument is warmed up and stable, add the zinc slurry to the sample. The arsenic peak should be detected almost immediately. A hydrogen-argon flame should be used. When the recorder response has approached baseline, remove the reaction vessel and replace with the next sample.

Calculations

Prepare a standard curve based on the absorbance and concentration of the arsenic standards. Determine the arsenic concentration in the sediment digests by comparing the sample absorbance with the standard curve. Calculate the arsenic concentration of the sediment sample as follows:

$$\text{As } \mu\text{g/kg (wet weight)} = \frac{(x) (0.1 \text{ l}) (1000)}{g}$$

$$\text{As } \mu\text{g/kg (dry weight)} = \frac{(x) (0.1 \text{ l}) (1000)}{(g) (\% S)}$$

where

x = the arsenic concentration in the sediment digest, $\mu\text{g/l}$

0.1 l = the final sample volume

g = the weight of wet sediment digested, g

% S = the percent solids in the sediments as a decimal fraction

METALS
(Mercury)

Mercury is also determined using a variation of the atomic absorption technique. However, due to the fact that a different digestion solution is used and the fact that mercury is quantified using a cold vapor technique rather than conventional flame atomic absorption spectrophotometry, mercury is discussed independent of the other metals.

Sample Handling and Storage

Samples for mercury analysis should preferably be stored in glass containers because it has been shown that polyethylene containers are permeable to mercury vapors.^{18*} The recommended method of sample preservation¹⁰ is to add nitric acid to a pH of 2 or less. The recommended holding time for samples preserved in this manner is 38 days for samples in glass and 13 days for samples in plastic (Figure 3-10). However, it has been reported^{19,20} that the addition of potassium dichromate and nitric acid is a better preservative than nitric acid alone. In either case, hydrochloric acid should not be used as a preservative since mercury may be lost as the volatile mercury chloride.²¹

The use of moist sediment samples is recommended. If samples are dried or frozen, care should be taken not to use excessively high temperatures during drying or thawing as this may result in the loss of volatile mercury compounds (Figure 3-10).

Procedure for Water Samples (W1, W2, S1A)

Method 1: Cold Vapor Technique^{5,10}

Apparatus

Atomic absorption spectrophotometer equipped with a glass cell as schematically indicated in Figure 3-11. Alternately,

* References for this procedure are found on page 3-136.

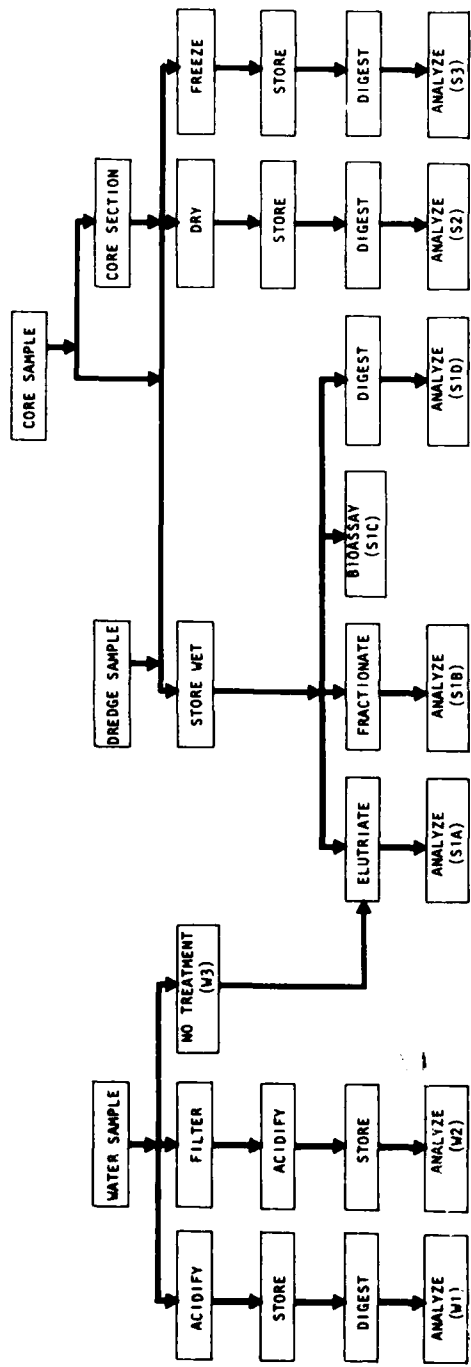

SAMPLE DESIGNATION	W1	W2	W3	STA	S1B	S1C	S1D	S2	S3
PURPOSE	Total Water Conc.	Soluble Water Conc.	Used in Elutriate	Mobile Conc.	Chemical Distribution	Bioavail- ability	Total Sediment Conc.	Total Sediment Conc.	Total Sediment Conc.
CONTAINER	G	G	G	G	G	G	G	G	G
SAMPLE TREATMENT	None	Filter	None	None	None	None	None	(-60°C)	Freeze
PRESERVATIVE	HNO ₃ pH<2	HNO ₃ pH<2	None	4°C (Minimize Air Contact. Keep Field Moist.)	4°C	4°C	4°C	None	None
STORAGE TIME	38d	38d	<1w	<1w	<1w	<1w	<1w	-	-
DIGESTION SOLUTION	Strong Acid	None	-	W3	Variable	-	Strong Acid	Strong Acid	Strong Acid
SAMPLE VOLUME OR WEIGHT	100-500 ml	100-500 ml	Variable	Variable	300-500 g	Variable	2-5 g	2-5 g	2-5 g

Figure 3-10. Handling and storage of samples for mercury analysis

Figure 3-11. Schematic cold vapor apparatus for mercury

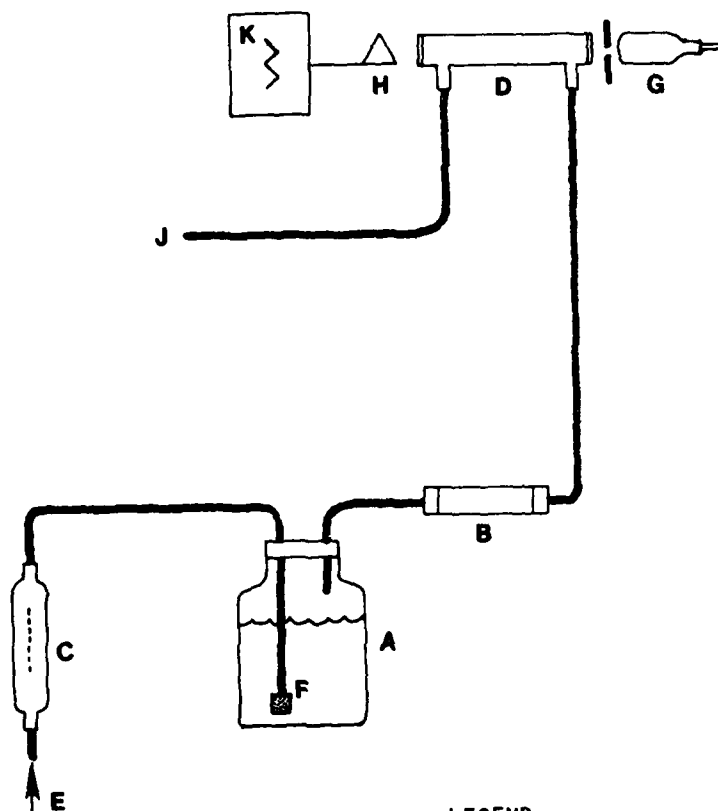

LEGEND:

- A - Reaction Flask
- B - Drying tube, filled with $MgClO_4$
- C - Rotameter, 2 liters of air per minute
- D - Absorption cell with quartz windows
- E - Compressed air, 2 liters of air per minute
- F - Glass tube with fritted end
- G - Hollow cathode mercury lamp
- H - AA detector
- J - Vent to hood
- K - Recorder, any compatible model

commercially available cold vapor technique instruments specifically designed for mercury analysis may be substituted for the atomic absorption spectrophotometer. The flow cell should be approximately 2.5 cm in diameter, as long as the instrument will permit, and have quartz windows on each end. Support the cell in the light path of the instrument to give maximum transmittance.

Mercury hollow cathode lamp

Air pump capable of delivering 1 to 2 l air/min

Flow meter capable of measuring 1 to 2 l/min

Aeration tubing: a straight glass frit having a coarse porosity. Tygon tubing is used for passage of the mercury vapor from the sample bottle to the absorption cell and through the apparatus.

Drying tube: 150 mm x 18 mm diameter containing 20 g magnesium perchlorate, $MgClO_4$.

Reagents

Sulfuric acid, conc.: reagent grade.

Sulfuric acid, 0.5 N: dilute 14.0 ml of conc. sulfuric acid to 1.0 l.

Nitric acid, conc.: reagent grade of low mercury content.

NOTE: If a high reagent blank is obtained, it may be necessary to distill the nitric acid.

Sodium chloride-hydroxylamine sulfate solution: dissolve 12 g of sodium chloride and 12 g of hydroxylamine sulfate in distilled water and dilute to 100 ml. (Hydroxylamine hydrochloride may be used in place of hydroxylamine sulfate.)

Potassium permanganate: 5 percent solution, w/v. Dissolve 5 g of potassium permanganate in 100 ml of distilled water.

Potassium persulfate: 5 percent solution, w/v. Dissolve 5 g of potassium persulfate in 100 ml of distilled water.

Stock mercury solution: dissolve 0.1354 g of mercuric chloride in 75 ml of distilled water. Add 10 ml of conc. nitric acid and adjust the volume to 100.0 ml. 1 ml = 1 mg Hg.

Stannous chloride: dissolve 100 g $SnCl_2$ in deionized distilled water containing 12.5 ml concentrated HCl and dilute to 1 l with deionized distilled water. Stir continuously during use if a suspension forms.

NOTE: A stannous sulfate solution may be prepared and used in place of the stannous chloride solution.

Working mercury solution: make successive dilutions of the stock mercury solution to obtain a working standard containing 0.1 g per ml. This working standard and the dilutions of the stock mercury solution should be prepared fresh daily. Acidity of

the working standard should be maintained at 0.15 percent nitric acid. This acid should be added to the flask as needed before the addition of the aliquot from the stock mercury solution.

Procedure

Transfer a 100-ml sample of each standard mercury solution and each W1, W2, and S1A sample to a 300-ml BOD bottle. Add 5 ml concentrated H_2SO_4 and 2.5 ml concentrated HNO_3 to each flask. Add 15 ml potassium permanganate solution to each flask and let stand a minimum of 15 min. Add 8 ml potassium persulfate solution to each flask and heat in a water bath at $95^\circ C$ for 2 hr. Following digestion, cool the samples to room temperature.

While the samples are digesting, set up the instrument according to the manufacturer's instructions. This would include:

- a. Install and align the hollow cathode lamp.
- b. Set the wavelength at 253.7 nm.
- c. Set the slit width and lamp current at recommended values.
- d. Allow the instrument to warm up.
- e. Install the mercury absorption cell.
- f. Adjust the air flow to 2 l/min.

Add 6 ml sodium chloride-hydroxylamine sulfate to the cooled sample digest. Allow at least 5 min to reduce any excess permanganate. From this point on, each standard and sample must be treated individually to completion.

Add 5 ml stannous chloride and immediately attach the BOD bottle to the aeration apparatus. The maximum absorbance should occur within a few seconds.

As soon as the recorder returns approximately to the baseline, remove the stopper holding the frit from the reaction flask and replace the sample bottle with a bottle containing deionized water. Flush the system for a few seconds and run the next sample/standard.

Because of the toxic nature of mercury vapor, care must be taken to avoid its inhalation. Therefore, the mercury vapor should be vented to an exhaust hood or through an absorbing media such as

(a) 0.1 M KMnO_4 and 10 percent H_2SO_4 or (b) 0.25 percent iodine in a 3 percent KI solution.

Calculations

Prepare a standard curve by plotting absorbance of the mercury standards versus mercury concentration. Determine the mercury concentration of the samples by comparing the sample absorbance with the standard curve.

Report the W1 sample results as total mercury and the W2 and S1A results as soluble mercury.

Procedure for Sediment Samples (S1D, S2, S3)

Method 1: Cold Vapor Technique^{11,21,22}

Apparatus

Atomic absorption spectrophotometer equipped with a glass cell and an aeration apparatus as shown in Figure 3-11. Alternately, commercially available cold vapor instruments designed specifically for mercury may be used

Mercury hollow cathode lamp

Air pump capable of delivering 2 l air/min

Flow meter capable of measuring 2 l/min

Aeration tubing: a straight glass frit having a coarse porosity. Tygon tubing is used for passage of the mercury vapor from the sample bottle to the absorption cell and through the apparatus

Drying tube: 150 mm x 18 mm diameter containing 20 g magnesium perchlorate, $MgClO_4$.

Reagents

Sulfuric acid, conc.: reagent grade.

Nitric acid, conc.: reagent grade of low mercury content.

NOTE: If a high reagent blank is obtained, it may be necessary to distill the nitric acid.

Sodium chloride-hydroxylamine sulfate solution: dissolve 12 g of sodium chloride and 12 g of hydroxylamine sulfate in distilled water and dilute to 100 ml. (Hydroxylamine hydrochloride may be used in place of hydroxylamine sulfate.)

Potassium permanganate: 5 percent solution, w/v. Dissolve 5 g of potassium permanganate in 100 ml of distilled water.

Potassium persulfate: 5 percent solution, w/v. Dissolve 5 g of potassium persulfate in 100 ml of distilled water.

Stock mercury solution: dissolve 0.1354 g of mercuric chloride in 75 ml of distilled water. Add 10 ml of conc. nitric acid and adjust the volume to 100.0 ml. 1 ml = 1 mg Hg.

Prepare working mercury solutions by appropriate dilution of the stock mercury solution on the day of use.

Stannous chloride: dissolve 100 g $SnCl_2$ in deionized distilled water containing 12.5 ml concentrated HCl and dilute to 1 l with deionized distilled water. Stir continuously during use if a suspension forms.

NOTE: A stannous sulfate solution may be prepared and used in place of the stannous chloride solution.¹⁰

Procedure

Set up the instrument according to the manufacturer's instructions. This should include:

- a. Installing and aligning the hollow cathode lamp.
- b. Setting the lamp wavelength at 253.7 nm.
- c. Setting the slit width and lamp current at recommended values.
- d. Allowing the instrument to warm up for 10 to 20 min.
- e. Installing the mercury absorption cell.
- f. Adjusting the air flow to 2 l/min.

Homogenize the sediment sample and weigh out a 0.5 to 2 g dry weight equivalent of the moist sample. Transfer the sample to a 300-ml BOD bottle and rinse the sediment to the bottom of the flask with distilled deionized water.

NOTE: Dried or frozen sediment samples may be used but moist samples are recommended since their use avoids the possible loss of volatile mercury compounds during the drying or thawing cycles.

Cool the sample in an ice bath and add 5 ml concentrated sulfuric acid and 5 ml concentrated nitric acid. The use of the ice bath is intended to counteract the heating of the sample that can result from the addition of the acid and the potential volatilization of mercury that may result.

Add 15 ml 5 percent potassium permanganate. If the pink permanganate color does not persist for 15 min, add additional permanganate. Digest the unstoppered sample for 2 hr in a 60°C water bath.

Cool the sample and add 5 ml potassium persulfate solution. Stopper the samples and allow to stand overnight. Add sufficient hydroxylamine sulfate-sodium chloride solution until the brown hydrated manganese oxides and excess potassium permanganate color are dissipated. Add approximately 100 ml distilled water.

Add 10 ml stannous chloride to the sample and immediately attach the sample to the aeration apparatus. The maximum absorbance should occur within a few seconds.

As soon as the recorder returns approximately to the baseline, remove the stopper holding the frit from the reaction flask

and replace the sample bottle with a bottle containing deionized water. Flush the system for a few seconds and run the next standard/sample.

Because of the toxic nature of mercury vapors, the sample should be vented to an exhaust hood or through an absorbing media such as (a) 0.1 M KMnO_4 and 10 percent H_2SO_4 or (b) 0.25 percent iodine in 3 percent KI.

Calculations

Prepare a standard curve based on the absorbance of the mercury standards and the amount of mercury in the prepared standards. Compare the sample absorbance to the standard curve to determine the amount of mercury in the sample digest. Calculate the mercury concentration in the sediment as follows:

$$\text{Hg } \mu\text{g/kg (wet weight)} = \frac{1000 \text{ x}}{\text{g}}$$

$$\text{Hg } \mu\text{g/kg (dry weight)} = \frac{1000 \text{ x}}{(\text{g}) (\% \text{ S})}$$

where

x = weight of mercury in the sample, μg

g = wet weight of sediment used, g

% S = percent solids in the sediment sample as a decimal fraction

METALS
(Selenium)

Sample Handling and Storage

Selenium samples can be preserved with nitric acid as indicated for most other metals (Table 3-8). This method is considered acceptable for water samples up to periods of 6 mo. Glass or plastic containers should be acceptable with sediment samples since both are acceptable with water samples. However, the time limits for sediment storage are not known.

Procedure for Water Samples (W1, W2, S1A)⁵

Method 1: Hydride Generation

Apparatus

Hydride generator as diagramed in Figure 3-9. This will include:

- a. Flow meter, capable of measuring 1 l/min
- b. Medicine dropper, capable of delivering 1.5 ml, fitted into a size "0" rubber stopper
- c. Reaction flask, which is a pear-shaped vessel with side arm and a 50-ml capacity. Both arms should have a 14/20 ground glass joint
- d. Special glass inlet-outlet tube constructed from a micro cold finger condenser with the portion below the ground glass joint cut off. A Scientific Glass JM-3325 or equivalent is suitable
- e. Drying tube consisting of a 100-mm-long polyethylene tube filled with glass wool

Magnetic stirrer

Atomic absorption spectrophotometer

Hollow cathode lamp

Reagents

Stannous chloride: dissolve 100 g SnCl₂ in 100 ml concentrated hydrochloric acid.

Zinc slurry: add 50 g 200 mesh zinc metal dust to 100 ml deionized distilled water.

References for this procedure are found on page 3-136.

Standard diluent: add 100 ml 18 N H_2SO_4 and 400 ml concentrated HCl to 400 ml deionized distilled water in a 1- ℓ volumetric flask and dilute to volume with deionized distilled water.

Stock selenium solution: dissolve 1.000 g selenium in 5 ml concentrated HNO_3 . Warm until the reaction is complete and cautiously evaporate just to dryness. Dilute to 1 ℓ with deionized distilled water. 1.00 ml = 1.00 mg Se. (Alternately dissolve 0.3453 g selenous acid (assay 94.6 percent H_2SeO_3) in deionized distilled water and dilute to 200 ml. 1.00 ml = 1.00 mg Se.

Intermediate selenium solution: pipet 1 ml stock selenium solution into a 100-ml volumetric flask and dilute to volume with deionized distilled water containing 1.5 ml concentrated HNO_3/ℓ . 1.00 ml = 10 μg Se.

Working selenium solution: pipet 10 ml intermediate selenium solution into a 100-ml volumetric flask and dilute to volume with deionized distilled water containing 1.5 ml concentrated HNO_3/ℓ . 1.00 ml = 1.00 μg Se. Prepare fresh on the day of use.

Perchloric acid, 70 to 72 percent.

Concentrated nitric acid.

18 N sulfuric acid: dilute 500 ml concentrated sulfuric acid to 1 ℓ with deionized distilled water.

Procedure

Treat the sample with hydrochloric acid to determine inorganic selenium (a) or nitric acid and sulfuric acid to determine total selenium (b). Organic selenium can be calculated as the difference between these two treatments.

Inorganic Selenium

- a. Pipet 25-ml W1, W2, or S1A sample into a 50-ml volumetric flask. Add 20 ml concentrated hydrochloric acid and dilute to volume with deionized distilled water.

Total Selenium

- b. (1) Pipet a 50-ml W1, W2, or S1A sample into a 150-ml beaker. Add 10 ml concentrated nitric acid and 12 ml 18 N sulfuric acid.
- (2) Evaporate the sample to the evolution of SO_3 fumes (approximately 20 ml). To avoid the loss of selenium, add small amounts of nitric acid whenever the red-brown NO_2 fumes disappear.
- (3) Cool slightly. Add 25 ml deionized distilled water, 1 ml perchloric acid, and evaporate to SO_3 fumes. Cool, add 40 ml concentrated

hydrochloric acid, and dilute to a volume of 100 ml with deionized distilled water.

Prepare standard selenium solution by diluting 0, 0.5, 1.0, 1.5, and 2.0 ml working selenium solution to 100 ml with the standard acid diluent. These solutions contain 0, 5, 10, 15, and 20 $\mu\text{g Se/l}$, respectively.

Pipet 25 ml of the sample [either (a) or (b)] or standard selenium solution into the reaction vessel. Add 0.5 ml stannous chloride solution and allow 10 min for the selenium to be reduced.

Attach the reaction vessel to the special gas inlet-outlet glassware. Fill the medicine dropper with 1.5 ml homogenized zinc slurry and insert the medicine dropper into the side neck of the reaction vessel. With the hydride generator attached to the atomic absorption spectrophotometer and the instrument producing a stable response with an argon-hydrogen flame, add the zinc slurry to the sample. The selenium hydride peak should occur almost immediately. When the recorder pen returns part way to the established baseline, remove the reaction vessel.

Continue processing samples and standards in a similar manner.

The following general procedure should be used when processing samples:

- a. Run a set of standards.
- b. Run five samples.
- c. Run a duplicate of the fifth sample.
- d. Run five samples.
- e. Run a duplicate and a spike of the fifth sample.
- f. Run a standard.
- g. Repeat the cycle.

In this way, a quality control program can be incorporated into the sample processing routine and the instrument stability can be checked.

Calculations

Prepare a standard curve by plotting standard absorbance versus selenium concentration in the standards. Determine the selenium concentration by comparing the sample absorbance with the

standard curve. Be sure to multiply the determined selenium concentrations by 2 as the samples were diluted 1:1 with acid and the standards were not.

Report results for W1 samples as total selenium and results for W2 and S1A samples as soluble selenium.

If it is necessary or desirable to determine organic selenium, this can be calculated as total selenium (digestion b) minus inorganic selenium (digestion a).

Procedures for Sediment Samples (S1D, S2, S3)

Method 1: Digestion/Flameless Atomic Absorption^{2 3}

Apparatus

Atomic absorption spectrophotometer equipped with a deuterium background corrector

Selenium electrodeless discharge lamp: operate at 9 watts, a slit width of 0.7 and 196.0 nm

Automatic sampler

Eppendorf microliter pipets may be used where an automatic sampler is not available

Graphite furnace: dry samples at 125°C, char samples at 1500°C for 30 sec, and atomize samples for 10 sec at 2700°C

Hot plate

Reagents

Concentrated nitric acid, redistilled.

Hydrogen peroxide, 30 percent.

Stock selenium solution: dissolve 0.3453 g selenous acid (assay 94.6 percent H_2SeO_3) in deionized-distilled water and dilute to 200 ml. 1.00 ml = 1.00 mg Se.

Intermediate selenium solution: pipet 1 ml stock selenium solution into a 100-ml volumetric flask and dilute to volume with deionized distilled water containing 1.5 ml concentrated nitric acid/l. 1.00 ml = 10 µg Se.

Prepare selenium standards in the appropriate range on the day of use. Add the selenium to a 100-ml volumetric flask containing 1 ml concentrated nitric acid and 2 ml 30 percent hydrogen peroxide. Dilute to volume with deionized distilled water.

1 percent nickel nitrate: dissolve 4.956 g $\text{Ni}(\text{NO}_3)_2 \cdot 6 \text{H}_2\text{O}$ in 100 ml deionized distilled water.

Nickel nitrate, 5 percent: dissolve 24.780 g $\text{Ni}(\text{NO}_3)_2 \cdot 6 \text{H}_2\text{O}$ in 100 ml deionized distilled water.

Procedure

Dry the sample to be analyzed at 60°C. Temperatures above this value are not recommended due to the possibility of selenium loss as a result of volatilization. Weigh a 0.5-g sample of the dried material (S1D, S2, S3) and transfer to a 250-ml Griffin beaker.

Add 5 ml concentrated HNO_3 to the sample and cover the beaker with a watch glass. Reflux the sample to near dryness at 95°C.

After the sample has cooled, add a second 5-ml portion of concentrated nitric acid and repeat the digestion. Cool the sample.

Add 3 ml concentrated nitric acid and 10 ml 30 percent hydrogen peroxide. Place the beaker on a hot plate and warm gently until a reaction commences. Immediately remove the beaker from the hot plate until the vigorous effervescence has subsided. Return the covered beaker to the hot plate and reflux the sample at 95°C for an additional 15 min.

Cool the sample and dilute to 50 ml with deionized distilled water.

Pipet 5 ml of digested sample or standard into a 10-ml volumetric flask. Add 2 ml 5 percent nickel nitrate solution and dilute to volume with deionized distilled water. Allow any particulate matter to settle before withdrawing an aliquot for analysis.

NOTE: Selenium standards and samples to be analyzed by the graphite furnace method are mixed with a nickel nitrate solution to enhance sensitivity. This step will double the sensitivity but care must be taken to treat samples and standards in a similar fashion to avoid introducing a differential matrix effect.

Because of possible matrix effects, the method of standard additions should be used. Additional 5-ml aliquots of the digested sample should be pipeted into 10-ml volumetric flasks and spiked with known amounts of selenium standard. Add 2 ml 5 percent nickel nitrate and dilute to volume with deionized distilled water.

Samples sizes of 5 to 10 μ l should be injected into the graphite furnace and dried for 20 sec, charred for 30 sec, and atomized for 10 sec. The small sample size is recommended to minimize possible interference in the sediment digests. If larger sample sizes are used, the drying time will have to be increased.

Record the data for standards, samples, and spiked samples.

Calculations

With the standard addition approach, plot the absorbance of the sample and the absorbance of the spiked samples versus the amount of added selenium. Extrapolate the data to determine the amount of selenium in the sample digest.

When using a series of standard selenium concentrations, plot standard absorbance versus selenium concentration. Determine the selenium concentration in the sample digest by comparing sample absorbance with the standard curve.

$$\text{Se } \mu\text{g/kg (wet weight)} = \frac{(x) (L) 1000}{E}$$

$$\text{Se } \mu\text{g/kg (dry weight)} = \frac{(x) (L) 1000}{(g) (\% S)}$$

where

x = selenium concentration in sample digest, $\mu\text{g}/\ell$

L = final volume of sample digest, ℓ (0.05 ℓ as written)

g = wet weight of sediment digested, g

% S = percent solids in sediment sample as a decimal fraction

Method 2: Hydride Generation

Apparatus

Atomic absorption spectrophotometer

Hydride generator as shown in Figure 3-9 and described in the procedure for the analysis of selenium in water samples. Use a 5-ml medicine dropper rather than a 1.5-ml medicine dropper

Reagents

Concentrated hydrochloric acid.

Stannous chloride: dissolve 40 g SnCl_2 in 100 ml concentrated hydrochloric acid.

Zinc slurry: add 50 g 200 mesh zinc metal dust to 100 ml deionized-distilled water.

Stock selenium solution: dissolve 1.000 g selenium in 5 ml concentrated HNO_3 . Warm until the reaction is complete and cautiously evaporate just to dryness. Dilute to 1 ℓ with deionized distilled water. 1.00 ml = 1.00 mg Se. (Alternately, a stock solution can be prepared by dissolving 0.3453 g selenous acid (assay 94.6 percent H_2SeO_3) in deionized distilled water and diluting to 200 ml. 1.00 ml = 1.00 mg Se.

Intermediate selenium solution: pipet 1 ml stock selenium solution into a 100-ml volumetric flask and dilute to volume with deionized distilled water containing 1.5 ml concentrated HNO_3/ℓ . 1.00 ml = 10 μg Se.

Prepare selenium standards in the appropriate range on the day of use.

Procedure

Weigh a 0.5- to 1.0-g dry weight equivalent of sediment sample (S1D, S2, S3) and transfer to a 150-ml beaker. Add 10 ml concentrated nitric acid and 12 ml 18 N sulfuric acid.

Cover the sample with a watch glass and heat on a hot plate until SO₃ fumes are evolved. To avoid the loss of selenium, replenish the nitric acid whenever the red-brown NO₂ fumes disappear.

Allow the sample to cool. Add 25 ml deionized distilled water and 1 ml perchloric acid and reheat the sample at 95°C until SO₃ fumes appear. Cool the sample and add 40 ml concentrated hydrochloric acid. Transfer the sample to a 100-ml volumetric flask and dilute to volume with deionized distilled water.

Prepare a series of standard selenium solutions. Pipet the appropriate amount of working selenium solution into a series of 100-ml volumetric flasks and dilute to volume with standard acid diluent.

Pipet 25 ml of digested sample or standard into the reaction vessel. Add 0.5 ml stannous chloride solution and allow 10 to 15 min for the selenium to be reduced.

Attach the reaction vessel to the special gas inlet-outlet glassware. Fill the medicine dropper with 1.5 ml homogenized zinc slurry and insert the medicine dropper into the side neck of the reaction vessel. With the hydride generator attached to the atomic absorption spectrophotometer and the instrument producing a stable response with an argon-hydrogen flame, add the zinc slurry to the sample. The selenium hydride peak should occur almost immediately. When the recorder pen returns part way to the established baseline, remove the reaction vessel. Continue processing standards and samples in a similar manner.

Calculations

Prepare a standard curve by plotting standard absorbance versus selenium concentration in the standards. Determine the selenium concentration in the sample digests by comparing the sample absorbance with the standard curve.

Calculate the selenium concentration in the sediment samples
as follows:

$$\text{Se } \mu\text{g/kg (wet weight)} = \frac{(x) (0.1 \text{ l}) (1000)}{g}$$

$$\text{Se } \mu\text{g/kg (dry weight)} = \frac{(x) (0.1 \text{ l}) (1000)}{(g) (\% S)}$$

where

x = selenium concentration in the sediment digest, $\mu\text{g/l}$

0.1 = volume of sediment digest, l

g = wet weight of sediment digested, g

% S = percent solids in the sediment sample as a decimal fraction

References

1. Stumm, W., and Morgan, J. J. Aquatic Chemistry. Wiley-Interscience; New York, New York. 538 p. (1978).
2. Williams, S. L., Aulenbach, D. B., and Clesceri, N. L. "Sources and Distribution of Trace Metals in Aquatic Environments." In: Aqueous Environmental Chemistry of Metals. A. J. Rubin (Ed.). Ann Arbor Science Publishers; Ann Arbor, Michigan. 390 p. (1974). pp. 77-127.
3. Helz, G. R. "Trace Element Inventory for the Northern Chesapeake Bay with Emphasis on the Influence of Man." Geochem et Cosmochem Acta 40:573-580 (1976).
4. Keeney, W. L., Breck, W. G., Vanloon, G. W., and Page, J. A. "The Determination of Trace Metals in Cladophora Glomerata -- C. Glomerata as a Potential Biological Monitor." Water Research 10: 981-984 (1976).
5. American Public Health Association. Standard Methods for the Examination of Water and Wastewater Including Bottom Sediments and Sludges. 14th Edition. APHA; New York, New York. 1193 p. (1976).
6. Delfino, J. J., and Enderson, R. E. "Comparative Study Outlines Methods of Analysis of Total Metal in Sludge." Water and Sewage Works 125(RN):R32-34, 47-48 (1978).
7. Varian Techtron. "Water Analysis by Atomic Absorption Spectroscopy." Varian Techtron; Palo Alto, California. 78 p. (1976).
8. Environment Canada. "Analytical Methods Manual." Inland Waters Directorate, Water Quality Branch; Ottawa, Ontario, Canada (1974).
9. Environmental Protection Agency. "Water Programs. Guidelines Establishing Test Procedures for the Analysis of Pollutants." Federal Register 41(232):52780-52786 (Wednesday, 1 December 1976).
10. Environmental Protection Agency. "Methods for Chemical Analysis of Water and Wastes." Environmental Monitoring and Support Laboratory, EPA; Cincinnati, Ohio (1979).
11. Walton, A. "Ocean Dumping Report 1. Methods for Sampling and Analysis of Marine Sediments and Dredged Materials." Department of Fisheries and Environment; Ottawa, Ontario, Canada. 74 p. (1978).
12. Environmental Effects Laboratory. "Ecological Evaluation of Proposed Discharge of Dredged or Fill Material into Navigable Waters. Interim Guidance for Implementation of Section 404(b)(1) of Public Law 92-500 (Federal Water Pollution Control Act Amendments of 1972)." Miscellaneous Paper D-76-17. U. S. Army Engineer Waterways Experiment Station, CE; Vicksburg, Mississippi. 83 p. (1976).

13. Delfino, J. J., Bortheson, G. C., and Lee, G. F. "Distribution of Mn, Fe, P, Mg, K, Na, and Ca in the Surface Sediments of Lake Mendota, Wisconsin." *Environmental Science and Technology* 3:1189-1192 (1969).
14. Agemian, H., Aspila, K. I., and Chau, A. S. Y. "A Comparison of the Extraction of Mercury from Sediments by Using Hydrochloric-Nitric Acid, Sulfuric-Nitric and Hydrofluoric Acid-Aqua Regia Mixture." *Analysis* 100:253-258 (1975).
15. Rosengrant, L. E. "A Method Study for the Digestion of Lacustrine Sediments for Subsequent Heavy Metal Analysis by Atomic Absorption Spectrophotometry." M.S. Thesis, State University College of New York at Buffalo; Buffalo, New York. 77 p. (1977).
16. Anderson, J. "A Study of the Digestion of Sediment by the HNO_3 - H_2SO_4 and the HNO_3 - HCl Procedures." *Atomic Absorption Newsletter* 13(1):31-32 (1974).
17. Oliver, B. G. "Heavy Metal Levels of Ottawa and Rideau River Sediments." *Environmental Science and Technology* 7:135-137 (1973).
18. Bothner, M. H., and Robertson, D. E. "Mercury Contamination of Sea Water Samples Stored in Polyethylene Containers." *Anal. Chem.* 47:592-595 (1975).
19. Lo, J. M., and Wai, C. M. "Mercury Loss from Water During Storage: Mechanisms and Preventions." *Anal. Chem.* 47:1869-1870 (1975).
20. Feldman, C. "Preservation of Dilute Mercury Solutions." *Anal. Chem.* 46:99-102 (1974).
21. Agemian, H., and Chau, A. S. Y. "A Method for Determination of Mercury in Sediments by the Automated Cold Vapor Atomic Absorption Technique After Digestion." *Analytica Chim. Acta* 75:297-304 (1975).
22. Ure, A. M., and Shand, C. A. "The Determination of Mercury in Soils and Related Materials by Cold-Vapor Atomic Absorption Spectrometry." *Analytica Chim. Acta* 72:63-77 (1974).
23. Martin, T. D., Koopp, J. F., and Ediger, R. D. "Determining Selenium in Water, Wastewater, Sediment, and Sludge by Flameless Atomic Absorption Spectroscopy." *Atomic Absorption Newsletter* 14: 109-116 (1975).

NITROGEN

(Ammonia, Nitrate, Nitrite, Total Kjeldahl, Organic)

Nitrogen may be distributed among many different forms in the environment. These various nitrogen species are important because they may contribute to eutrophication, they may be potentially toxic, or they may affect the environmental chemistry of other constituents such as metals by complexation and/or chelation. However, the inter-conversion of nitrogen species can create problems during the analysis of samples. For example, nitrite can be chemically oxidized to nitrate while algae and bacteria can alter ammonia, nitrate, or organic nitrogen concentrations. In addition, poorly protected samples can pick up ammonia from the atmosphere. These effects can be minimized by analyzing samples as soon as possible.

This section presents analytical procedures for ammonia, nitrate, nitrite, total Kjeldahl nitrogen, and organic nitrogen. Before presenting these procedures, the relationship between these parameters and their analytical techniques will be briefly summarized:

- a. Ammonia - This parameter is measured either colorimetrically or titrimetrically. The analytical procedures measure total ammonia. Therefore, if ammonia toxicity is of concern, temperature and pH of the original sample should be measured.
- b. Nitrate - One procedure (Brucine Sulfate) measures nitrate directly. The remaining procedures rely on a reduction of nitrate to nitrite and a subsequent quantification of the nitrite. Thus, nitrate is calculated as total nitrate plus nitrite minus nitrite.
- c. Nitrite - The nitrate plus nitrite procedures actually measure nitrite. Therefore, the nitrite concentration can be determined directly by omitting the nitrate reduction step (either the cadmium reduction column or hydrazine sulfate treatment).
- d. Total Kjeldahl Nitrogen - The procedure catalytically reduces organic nitrogen to ammonia. This measurement, therefore, includes organic nitrogen and ammonia.

- e. Organic Nitrogen - This parameter can be calculated as total Kjeldahl nitrogen minus ammonia nitrogen. Alternately, it may be determined by distilling off the ammonia at pH 9.5 and then running total Kjeldahl nitrogen on the sample residue.

NITROGEN
(Ammonia)

Sample Handling and Storage

A flow diagram summarizing the pertinent information regarding sample handling and storage is presented in Figure 3-12. Samples may be collected in either glass or plastic. They should be analyzed as soon as possible and preferably within 24 hr. Sample stability can be improved by adding sulfuric acid, tightly capping the sample bottle, and storing at 4°C until analyzed. The volume of sample required will vary from 20 to 25 ml for the automated procedures to 500 ml for a manual procedure.

Procedures for Water Samples (W1, W2, S1A)

Method 1: Colorimetric, Automated Phenate^{1,2*}

This procedure is suitable for samples with ammonia concentrations in the range of 0.01 to 2.0 mg N₃-N/l. It is based on the reaction of ammonia with alkaline phenol and hypochlorite to form indophenol. The color is intensified with sodium nitroprusside and measured colorimetrically.

Apparatus

Technicon AutoAnalyzer Unit (AAI or AAI) consisting of:

- a. Sampler
- b. Manifold (AAI) or analytical cartridge (AAI)
- c. Proportioning pump
- d. Heating bath with double delay coil (AAI)
- e. Colorimeter equipped with 15-mm tubular flow cell and 630 to 660-nm filters
- f. Recorder
- g. Digital printer for AAI (optional)

* References are on page 3-206.

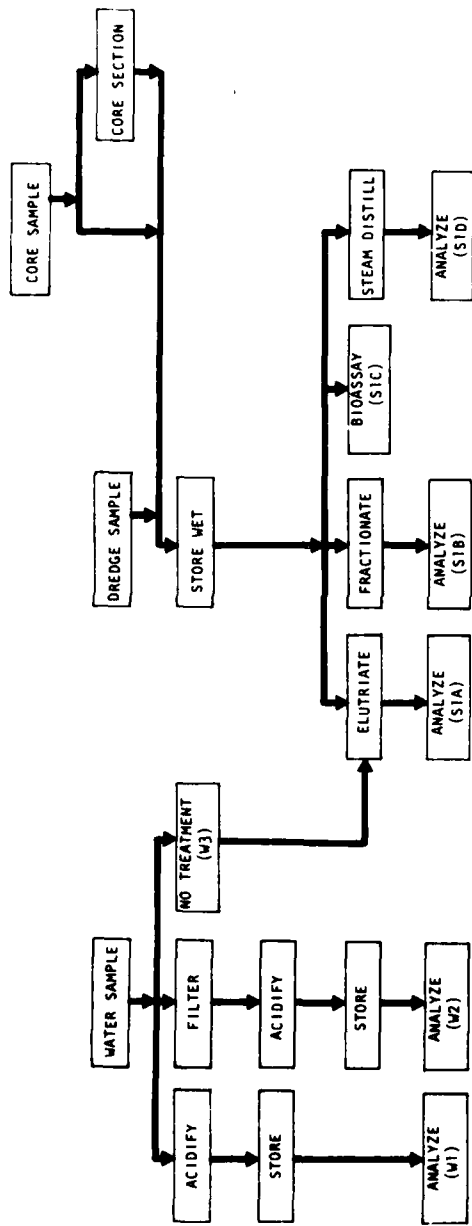

SAMPLE DESIGNATION	W1	W2	W3	S1A	S1B	S1C	S1D
PURPOSE	Total Water Conc.	Soluble Water Conc.	Used in Elutriate	Mobile Conc.	Chemical Distribution	Bioavail- ability	Total Sediment Conc.
CONTAINER	G,P	G,P	G,P	G,P	G,P	G,P	G,P
SAMPLE TREATMENT	None	Filter	None	None	None	None	None
PRESERVATIVE	H ₂ SO ₄ pH 2 4°C	H ₂ SO ₄ pH 2 4°C	None	4°C (Minimize Air Contact. Keep Field Moist.)	4°C	4°C	4°C
STORAGE TIME	24 hr	24 hr	<1 w	<1 w	<1 w	<1 w	<1 w
DIGESTION SOLUTION	-	-	-	-	Variable	-	Steam Distillation
SAMPLE VOLUME OR WEIGHT	20-500 ml	20-500 ml	20-500 m	20-500 m	-	-	0.5-1.0 g

Figure 3-12. Sample handling and storage for ammonia analysis

Reagents

Distilled water: special precaution must be taken to ensure that distilled water is free of ammonia. Such water is prepared by passage of distilled water through an ion exchange column comprised of a mixture of both strongly acidic cation and strongly basic anion exchange resins. The regeneration of the ion exchange column should be carried out according to the instruction of the manufacturer.

NOTE: All solutions must be made using ammonia-free water.

Sulfuric acid 5 N: air scrubber solution. Carefully add 139 ml of conc. sulfuric acid to approximately 500 ml of ammonia-free distilled water. Cool to room temperature and dilute to 1 l with ammonia-free distilled water.

Sodium phenolate: using a 1-l Erlenmeyer flask, dissolve 83 g phenol in 500 ml of distilled water. In small increments, cautiously add, with agitation, 32 g of NaOH. Periodically cool the flask under water faucet. When cool, dilute to 1 l with distilled water.

Sodium hypochlorite solution: dilute 250 ml of a bleach solution containing 5.25 percent NaOCl (such as Clorox) to 500 ml with distilled water. Available chlorine level should approximate 2 to 3 percent. Since Clorox is a proprietary product, its formulation is subject to change. The analyst must remain alert to detecting any variation in this product significant to its use in this procedure. Due to the instability of this product, storage over an extended period should be avoided.

Dissolve ethylenediamine-tetraacetate (EDTA) (5 percent): dissolve 50 g of EDTA (disodium salt) and approximately six pellets of NaOH in 1 l of distilled water.

NOTE: On saltwater samples where EDTA solution does not prevent precipitation of cations, sodium potassium tartrate solution may be used to advantage. It is prepared as follows:

Sodium potassium tartrate solution: 10 percent $\text{NaKC}_4\text{H}_4\text{O}_6 \cdot 4 \text{H}_2\text{O}$. To 900 ml of distilled water add 100 g sodium potassium tartrate. Add two pellets of NaOH and a few boiling chips; boil gently for 45 min. Cover, cool, and dilute to 1 l with ammonia-free distilled water. Adjust pH to 5.2 ± 0.05 with H_2SO_4 . After allowing to settle overnight in a cool place, filter to remove precipitate. Then add 0.5 ml Brij-35[®] (available from Technicon Corporation) solution and store in stoppered bottle.

Sodium nitroprusside (0.05 percent): dissolve 0.5 g of sodium nitroprusside in 1 l of distilled water.

Stock solution: dissolve 3.819 g of anhydrous ammonium chloride, NH_4Cl , dried at 105°C , in distilled water, and dilute to 1000 ml. 1.0 ml = 1.0 m μ $\text{NH}_3\text{-N}$.

Standard solution A: dilute 10.0 ml of stock solution to 1000 ml with distilled water. 1.0 ml = 0.01 mg NH₃-N.

Standard solution B: dilute 10.0 ml of standard solution A to 100.0 ml with distilled water. 1.0 ml = 0.001 mg NH₃-N.

Working ammonia standards should be prepared fresh on the day of use. They can be prepared by diluting either standard solution A or standard solution B as indicated below:

<u>NH₃-N, mg/l</u>	<u>ml Standard Solution/100 ml</u>
	<u>Solution B</u>
0.01	1.0
0.02	2.0
0.05	5.0
0.10	10.0
	<u>Solution A</u>
0.20	2.0
0.50	5.0
0.80	8.0
1.00	10.0
1.50	15.0
2.00	20.0

When freshwater samples are being analyzed, the working ammonia standards should be diluted to volume with ammonia-free distilled water. When saltwater samples are being analyzed, the working ammonia standards should be diluted to volume with Substitute Ocean Water (SOW) that has the following composition:

<u>Substitute Ocean Water (SOW)</u>			
NaCl	24.53 g/l	NaHCO ₃	0.20 g/l
MgCl	5.20 g/l	KBr	0.10 g/l
Na ₂ SO ₄	4.09 g/l	H ₃ BO ₃	0.03 g/l
CaCl ₂	1.16 g/l	SrCl	0.03 g/l
KCl	0.70 g/l	NaF	0.003 g/l

If SOW is used, subtract its blank background response from the standards before preparing the standard curve.

Procedure

Since the intensity of the color used to quantify the concentration is pH dependent, the acid concentration of the wash water and the standard ammonia solutions should be approximately that of the samples. For example, if the samples have been preserved with 2 ml conc. H₂SO₄/l, the wash water and standards should also contain 2 ml conc. H₂SO₄/l.

For a working range of 0.01 to 2.00 mg NH₃-N/l (AAI), set up the manifold as shown in Figure 3-13. For a working range of 0.01 to 1.0 mg NH₃-N/l (AAII), set up the manifold as shown in Figure 3-14. Higher concentrations may be accommodated by sample dilution. Allow both colorimeter and recorder to warm up for 30 min. Obtain a stable baseline with all reagents, feeding distilled water through sample line.

For the AAI system, sample at a rate of 20/hr, 1:1. For the AAII, use a 60/hr, 6:1 cam with a common wash.

Arrange ammonia standards in sampler in order of decreasing concentration of nitrogen. Complete loading of sampler tray with unknown samples.

Switch sample from distilled water to sampler and begin processing samples.

Calculations

Prepare appropriate standard curve derived from processing ammonia standards through manifold. Compute concentration of samples by comparing sample peak heights with standard curve.

Method 2: Colorimetric, Automated O-tolidine³

This procedure is suitable for samples with ammonia concentrations in the range of 0.001 to 0.10 mg NH₃-N/l. It is based on the reaction between ammonia and hypochlorite. The product is reacted with O-tolidine and quantified colorimetrically.

Apparatus

Technicon AutoAnalyzer unit consisting of:

- a. Sampler
- b. Manifold
- c. Proportioning pump
- d. Dialyzer
- e. Heating bath (40°C)
- f. Colorimeter equipped with a 50-mm flow cell and 420-nm filters
- g. Range expander
- h. Recorder

Figure 3-13. AAI manifold for phenate determination of ammonia

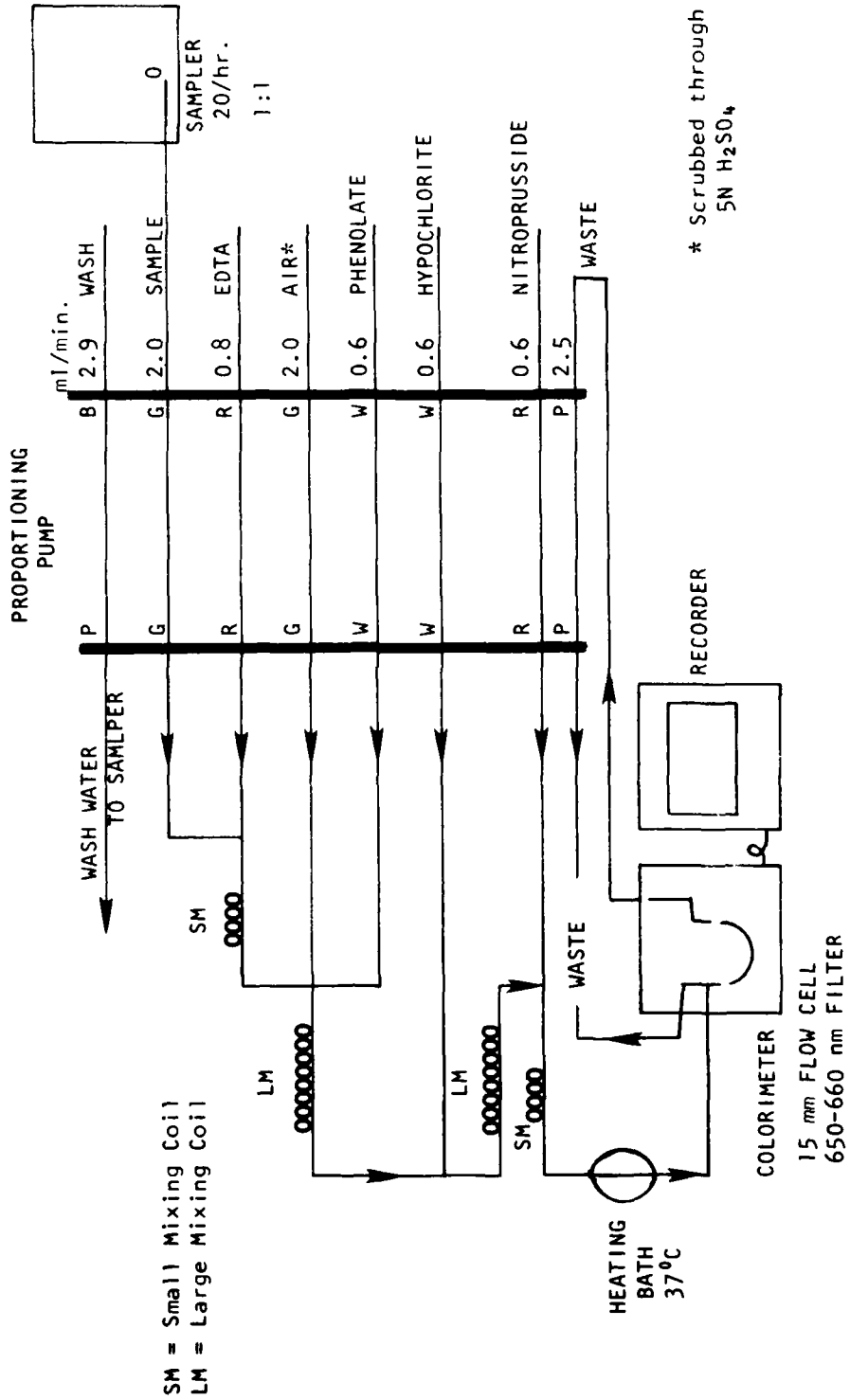
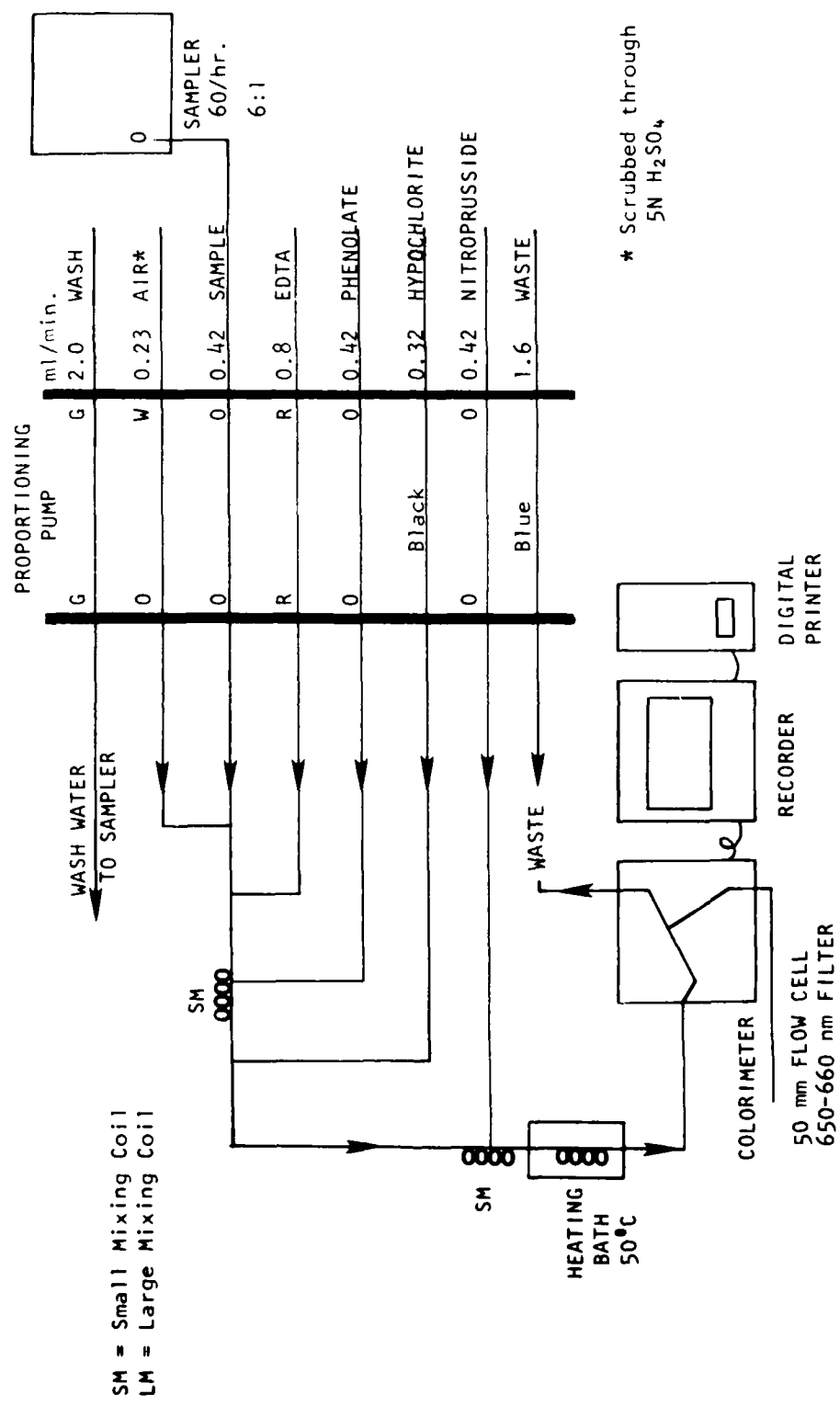

Figure 3-14. AAI artridge for phenate determination of ammonia



Reagents

Alkaline complexing agent:

Solution A: dissolve 52 g sodium hydroxide, NaOH, in 1 ℓ deionized water.

Solution B: dissolve 40 g sodium hexametaphosphate in 1 ℓ deionized water.

The alkaline complexing agent should be prepared fresh daily by mixing equal volumes of solution A and solution B (i.e. 100 ml A and 100 ml B).

Buffer: dissolve 96 g hydrated disodium hydrogen phosphate and 10 g sodium dihydrogen phosphate in 5 ℓ deionized water (pH 7.5).

Sodium hypochlorite: dilute sodium hypochlorite solution (Clorox is suitable) to approximately 0.004 percent available chlorine with deionized water.

Oxalic acid: dissolve 20 g oxalic acid and 170 g monochloroacetic acid in deionized water and make up to 1 ℓ.

Orthotolidine: prepare by heating 1.2 g O-tolidine dihydrochloride in 120 ml conc. hydrochloric acid, HCl, at 60°C for 1 hr; then adjust to a volume of 1 ℓ with distilled water.

Stock ammonia solution: dissolve 3.819 g anhydrous ammonium chloride, NH₄Cl, dried at 100°C, in distilled water and dilute to 1 ℓ. This solution contains 1000 mg/ℓ N.

Intermediate ammonia solution, 10 mg/ℓ: dilute 10.00 ml stock ammonia solution to 1 ℓ with deionized water.

Standard ammonia solution, 1 mg/ℓ N: dilute 100 ml intermediate ammonia solution to 1 ℓ with deionized water.

Working ammonia standards: using standard ammonia solution, prepare working ammonia standards in 100 ml-volumetric flasks. Prepare fresh on the day of use. The following standards are suggested:

<u>Ammonia N, mg/ℓ</u>	<u>ml Standard Solution/100 ml</u>
0.002	0.2
0.01	1.0
0.02	2.0
0.05	5.0
0.10	10.0
0.15	15.0
0.20	20.0

Procedure

Arrange ammonia standards in sample tray in order of decreasing nitrogen concentration. Complete loading of tray with samples.

NOTE: Samples and standards may gain ammonia as the result of atmospheric contact. One lab has found it convenient to cover loaded sample trays with Saran Wrap to prevent atmospheric contamination. The protective covering is left in place during analysis and the metallic needlelike probe of the sampler is allowed to puncture the wrapping for each sample.³

Samples and standards are run at a rate of 20/hr using a manifold set up as shown in Figure 3-15.

If the sample response is off scale, one of the following techniques must be implemented to analyze the samples:

- a. Replace the colorimeter flow cell with a smaller flow cell.
- b. Remove range expander.
- c. Replace sample line with a smaller line and add a distilled water line to make up the volume difference.
- d. Dilute the samples prior to loading the sample tray.

Calculations

Prepare a calibration curve derived from the peak heights obtained with the standard solutions.

Determine the concentration of ammonia in the samples by comparing sample peak heights with the calibration curve.

Method 3: Colorimetric or Titrimetric, Manual^{1,2,4}

This method is applicable over a wide range of ammonia concentrations. Ammonia is distilled from the sample buffered at a pH of 9.5 and collected in a boric acid solution. The ammonia is then quantified colorimetrically by nesslerization or titrimetrically. The former procedure is suitable for ammonia concentrations in the range of 0.05 to 1.0 mg NH₃-N/l and the latter technique is useful for samples with ammonia concentrations in the range of 1.0 to 25 mg NH₃-N/l.

Apparatus

An all-glass distilling apparatus with an 800- to 1000-ml flask
Spectrophotometer or filter photometer for use at 425 nm and providing a light path of 1 cm or more

Nessler tubes: matched Nessler tubes (APHA Standard) about 300 mm long, 17 mm inside diameter, and marked at 225 mm + 1.5 mm inside measurement from bottom

Figure 3-15. AA manifold for the O-tolidine determination of ammonia

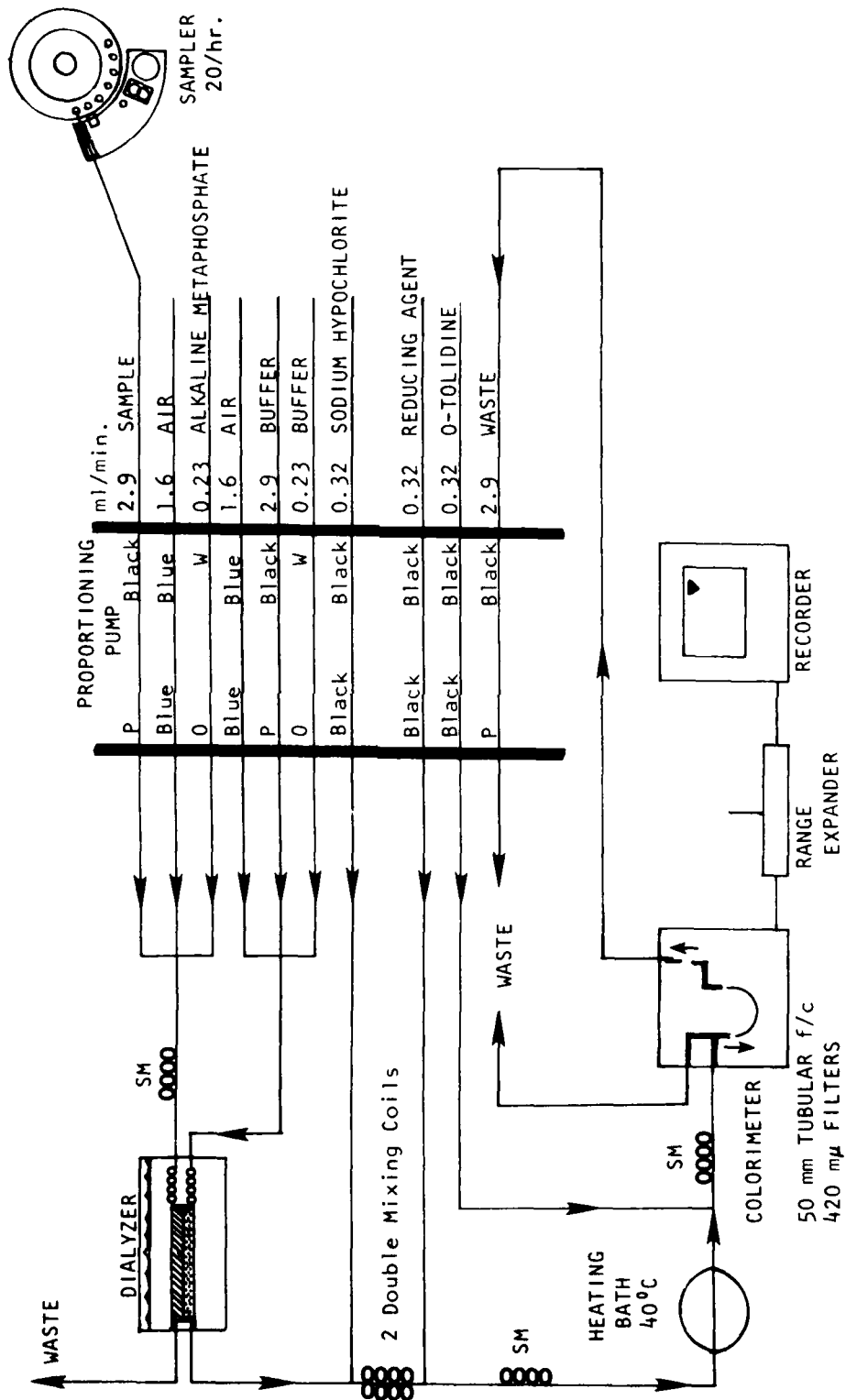

Erlenmeyer flasks: the distillate is collected in 500-ml glass-stoppered flasks. These flasks should be marked at the 350- and the 500-ml volumes. With such marking it is not necessary to transfer the distillate to volumetric flasks.

Reagents

Distilled water should be free of ammonia. Such water is best prepared by passage through an ion exchange column containing a strongly acidic cation exchange resin mixed with a strongly basic anion exchange resin. Regeneration of the column should be carried out according to the manufacturer's instructions.

NOTE: All solutions must be made with ammonia-free water.

Ammonia chloride, stock solution: 1.0 ml = 1.0 mg $\text{NH}_3\text{-N}$. Dissolve 3.819 g NH_4Cl in distilled water and bring to volume in a 1- ℓ volumetric flask.

Ammonium chloride, standard solution: 1.0 ml = 0.01 mg. Dilute 10.0 ml of stock ammonia chloride solution to 1 ℓ in a volumetric flask.

Boric acid solution (20 g/ ℓ): dissolve 20 g H_3BO_3 in distilled water and dilute to 1 ℓ .

Mixed indicator: mix two volumes of 0.2 percent methyl red in 95 percent ethyl alcohol with 1 volume of 0.2 percent methylene blue in 95 percent ethyl alcohol. This solution should be prepared fresh every 30 days.

NOTE: Specially denatured ethyl alcohol conforming to Formula 3A or 3B of the U. S. Bureau of Internal Revenue may be substituted for 95 percent ethanol.

Nessler reagent: dissolve 100 g of mercuric iodide and 70 g of potassium iodide in a small amount of water. Add this mixture slowly, with stirring, to a cooled solution of 160 g of NaOH in 500 ml of water. Dilute the mixture to 1 ℓ . If this reagent is stored in a Pyrex bottle out of direct sunlight, it will remain stable for a period of up to 1 year.

NOTE: This reagent should give the characteristic color with ammonia within 10 min after addition and should not produce a precipitate with small amounts of ammonia (0.04 mg in a 50-ml volume).

Borate buffer: add 88 ml of 0.1 N NaOH solution to 500 ml of 0.025 M sodium tetraborate solution (5.0 g anhydrous $\text{Na}_2\text{B}_4\text{O}_7$ or 0.5 g $\text{Na}_2\text{B}_4\text{O}_7 \cdot 10\text{H}_2\text{O}$ per liter) and dilute to 1 ℓ .

Sulfuric acid, standard solution: 0.02 N, 1 ml = 0.28 mg $\text{NH}_3\text{-N}$. Prepare a stock solution of approximately 0.1 N acid by diluting 3 ml of conc. H_2SO_4 (sp. gr. 1.84) to 1 ℓ with CO_2 -free distilled water. Dilute 200 ml of this solution to 1 ℓ with CO_2 -free distilled water.

NOTE: An alternate and perhaps preferable method is to standardize the approximately 0.1 N H_2SO_4 solution against a 0.100 N Na_2CO_3 solution. By proper dilution, the 0.02 N acid can then be prepared.

Standardize the approximately 0.02 N acid against 0.0200 N Na_2CO_3 solution. This last solution is prepared by dissolving 1.060 g anhydrous Na_2CO_3 , oven dried at 140°C , and diluting to 1000 ml with CO_2 -free distilled water.

Sodium hydroxide, 1 N: dissolve 40 g NaOH in ammonia-free water and dilute to 1 l.

Dechlorinating reagents: a number of dechlorinating reagents may be used to remove residual chlorine prior to distillation. These include:

- a. Sodium thiosulfate (0.0142 N): dissolve 3.5 g $\text{Na}_2\text{S}_2\text{O}_3 \cdot 5\text{H}_2\text{O}$ in distilled water and dilute to 1 l. One milliliter of this solution will remove 1 mg/l of residual chlorine in 500 ml of sample.
- b. Sodium arsenite (0.0142 N): dissolve 1.0 g NaAsO_2 in distilled water and dilute to 1 l.

Procedure

Preparation of equipment: add 500 ml of distilled water to an 800-ml Kjeldahl flask. The addition of boiling chips which have been previously treated with dilute NaOH will prevent bumping. Steam out the distillation apparatus until the distillate shows no trace of ammonia with Nessler reagent.

Sample preparation: remove the residual chlorine in the sample by adding dechlorinating agent equivalent to the chlorine residual. To 400 ml of sample, add 1 N NaOH until the pH is 9.5, checking the pH during addition with a pH meter or by use of a short-range pH paper.

Distillation: transfer the sample, the pH of which has been adjusted to 9.5, to an 800-ml Kjeldahl flask and add 25 ml of borate buffer. Distill 300 ml at the rate of 6 to 10 ml/min into 50 ml of 2 percent boric acid contained in a 500-ml Erlenmeyer flask.

NOTE: The condenser tip or an extension of the condenser tip must extend below the level of the boric acid solution.

Dilute the distillate to 500 ml with distilled water and nesslerize an aliquot to obtain an approximate value of the ammonia-nitrogen concentration. For concentrations above 1 mg/l, the ammonia should be determined titrimetrically. For concentrations below this value, it is determined colorimetrically.

Titrimetric determination: add 3 drops of the mixed indicator to the distillate and titrate the ammonia with the 0.02 N H₂SO₄, matching the end point against a blank containing the same volume of distilled water and H₃BO₃ solution.

Colorimetric determination: prepare a series of Nessler tube standards as follows:

<u>ml of Standard</u> <u>1.0 ml = 0.01 mg NH₃-N</u>	<u>mg NH₃-N/50.0 ml</u>
0.0	0.0
0.5	0.005
1.0	0.01
2.0	0.02
3.0	0.03
4.0	0.04
5.0	0.05
8.0	0.08
10.0	0.10

Dilute each tube to 50 ml with distilled water; add 2.0 ml of Nessler reagent and mix. After 20 min, read the absorbance at 425 nm against the blank. From the values obtained, plot absorbance vs. mg NH₃-N for the standard curve. Determine the ammonia in the distillate by nesslerizing 50 ml or an aliquot diluted to 50 ml and reading the absorbance at 425 nm as described above for the standards. Ammonia-nitrogen content is read from the standard curve.

It is not imperative that all standards be distilled in the same manner as the samples. It is recommended that at least two standards (a high and low) be distilled and compared to similar values on the curve to ensure that the distillation technique is reliable. If distilled standards do not agree with undistilled standards, the operator should find the cause of the apparent error before proceeding.

Calculations

Titrimetric:

$$\text{mg/l NH}_3\text{-N} = \frac{A \times 0.28 \times 1000}{S}$$

where

A = ml 0.02 N H₂SO₄ used

S = ml sample

Spectrophotometric:

$$\text{mg/l NH}_3\text{-N} = \frac{A \times 1000}{D} \times \frac{B}{C}$$

where

A = mg NH₃-N read from standard curve

B = ml total distillate collected, including boric acid and dilution

C = ml distillate taken for nesslerization

D = ml of original sample taken

Procedures for Sediment Samples (SID)

The determination of ammonia in sediments should be considered operationally defined because of the subjective nature of sample pre-treatment. Ammonia is extracted from sediments using a salt solution. While this will remove the exchangeable ammonia, similar to the cation exchange capacity procedure, and is considered a reproducible procedure,⁵ the samples are not subjected to exhaustive digestion. However, the use of acid may destroy nitrites in the sample and acid digestion may result in the conversion of organic nitrogen to ammonia.

Sample Handling and Storage

It is recommended that ammonia determinations only be run on sediment samples stored in a field moist condition (Figure 3-12). This recommendation is based on the possibility that ammonia may be lost by volatilization during the drying or thawing of samples stored in other conditions. In addition, samples should be processed in a week or less to minimize the effects of ammonia conversion or ammonia absorption.

Method 1: Potassium Chloride Extraction

Apparatus

Wrist-action or equivalent mechanical shaker

Filtration apparatus

Erlenmeyer flasks, 150 ml

Volumetric flasks, 100 ml

Reagents

Ammonia-free distilled water

Potassium chloride, 2 M: dissolve 149.11 g KCl in ammonia-free distilled water and dilute to 1 l.

Procedure

Weigh a 20-g sample of wet sediment and transfer to a 150-ml Erlenmeyer flask. Add 50 ml of 2 M KCl and seal the flask.

Shake the sample on a wrist-action or equivalent mechanical

shaker for 30 min. Since the procedure is operationally defined, the shaking time should be standardized for all samples.

Filter the sample through a prewashed 0.45- μ m pore-size membrane filter. Collect the filtrate in a 100-ml volumetric flask. Wash the solids with a second 50-ml portion of 2 M KCl. Repeat the filtration process and add the filtrate to the volumetric flask. Dilute the sample to volume with ammonia-free distilled water.

Analyze the samples by one of the procedures listed for ammonia in water.

Calculations

Determine the ammonia concentration of the KCl leachate using the appropriate standard curve. Calculate the ammonia concentration of the sediment sample as follows:

$$\text{Ammonia-N mg/kg (wet basis)} = \frac{(x)(y)(1000)}{g}$$

where

x = ammonia concentration in leachate, mg/l

y = sample volume, l (0.1 l as described)

g = wet weight of sediment sample extracted, g

Ammonia concentrations on a dry weight basis can be calculated by dividing the wet weight concentration by the percent solids in the sediment sample, expressed as a decimal fraction.

Method 2: Distillation

Ammonia is distilled from a sample and trapped in a boric acid solution. The distillate is then analyzed using one of the ammonia methods listed in the section for water analysis. The apparatus and reagents will depend on the method selected.

Apparatus

Kjeldahl digestion apparatus

Reagents

Ammonia-free water.

Phosphate buffer solution, pH 7.4: dissolve 14.3 g anhydrous potassium dihydrogen phosphate, KH_2PO_4 , and 68.8 g anhydrous dipotassium hydrogen phosphate, K_2HPO_4 , and dilute to 1 l with ammonia-free water.

Boric acid solution: dissolve 20 g anhydrous boric acid, H_3BO_3 , in ammonia-free water and dilute to 1 l.

Procedure

Weigh a 0.5- to 1.0-g sample of wet sediment. Transfer the sample to a 100-ml Erlenmeyer flask and add approximately 50 ml ammonia-free water and 3 to 4 drops concentrated sulfuric acid. This will stabilize the ammonia and the procedure can be interrupted at this point if necessary.

Steam out the distillation apparatus. Add 500 ml ammonia-free water, 10 ml phosphate buffer, and a few boiling stones to an 800-ml flask and steam the apparatus until there is no trace of ammonia in the distillate.

Transfer the acidified sediment slurry to an 800-ml Kjeldahl flask and add 500 ml ammonia-free water and a few boiling stones. Boil for a few minutes to remove any sulfides that may be present. This step will also remove any volatile organics such as formaldehyde that may interfere with the nesslerization procedure.

NOTE: Sulfide interferences may also be removed by precipitating the sulfide with lead carbonate.

Neutralize the sample to a pH of about 6.6 and add 10 ml phosphate buffer. Distill over 300 ml of sample at a rate of 6 to 10 ml/min and collect in 50 ml boric acid solution. Dilute the distillate to 500 ml with ammonia-free water.

Analyze the distillate using either the automated methods, direct nesslerization, or titration as described earlier. Nesslerization should be used if the ammonia concentration is less than 1 mg NH_3-N/l , and titration should be used when the ammonia concentration is greater than 1 mg NH_3-N/l .

The residue in the distillation flask can be used to determine organic nitrogen. By subjecting the residue to a Kjeldahl digestion, the result is a measure of organic carbon since this parameter is defined as total Kjeldahl nitrogen minus ammonia nitrogen.

Calculations

$$\text{Ammonia-nitrogen mg } NH_3-N/\text{kg (wet basis)} = \frac{(x)(y)(1000)}{g}$$

where

x = ammonia concentration in distillate, mg/l

y = volume of distillate, l

w = wet weight of sediment used, g

$$\text{Ammonia-nitrogen mg NH}_3\text{-N/kg (dry basis)} = \frac{(x)(y)(1000)}{w (\% S)}$$

where

x = ammonia concentration in distillate, mg/l

y = volume of distillate, l

w = wet weight of sediment used, g

% S = percent solids as a decimal fraction

Method 3: Distilled Water Extraction

Ammonia is separated from the sediment using an aqueous extraction technique. The liquid phase is then analyzed for ammonia using the method of choice in the Procedures for Water Samples section, which begins on page 3-140. This procedure is operationally defined and, therefore, must be carefully followed.

Procedure

Weigh out 0.5 to 1.0 g wet sediment and transfer to a 250-ml Erlenmeyer flask. Add 100 ml ammonia-free distilled water. Thoroughly mix and allow suspension to settle overnight.

Transfer to a centrifuge tube and centrifuge 10 min at 2000 rpm. Decant liquid to a 200-ml volumetric flask.

Add 50 ml ammonia-free distilled water to the sediment and mix. Centrifuge as before and add the wash to the initial extract.

Dilute the combined extract to volume with ammonia-free distilled water and analyze by the ammonia method of choice in the "Procedures for Water Samples" section.

Calculations

The ammonia concentration of the sediment samples is calculated as follows:

$$\text{Ammonia mg/kg (wet weight)} = \frac{(x)(y)(1000)}{w}$$

$$\text{Ammonia mg/kg (dry weight)} = \frac{(x)(y)(1000)}{(g)(\% S)}$$

where

x = ammonia concentration in extract, mg/l

y = volume of extract, l (0.2 as written)

g = wet weight of sediment, g

% S = percent solids in sediment (as decimal fraction)

NITROGEN
(Nitrate)

Sample Handling and Storage

Samples may be collected and stored in either plastic or glass containers. The accepted preservative for this parameter is sulfuric acid to a pH of 2 and refrigeration at 4°C. This combination of preservatives may stabilize samples for as long as 4 weeks⁶ but it is generally recommended that samples be analyzed within 24 hr. This information is presented in Figure 3-16.

The volume of sample required depends on the analytical method of choice and ranges from 10 ml for the nitrate-specific procedure (Brucine Sulfate) to 100 ml for the manual nitrate-nitrite procedure.

Procedures for Water Samples (W1, W2, S1A)

Method 1: Colorimetric, Manual, Brucine Sulfate^{1,2}

The procedure is based on the reaction between nitrate and brucine sulfate in a highly acidic medium. The resulting product is then quantified colorimetrically. Temperature control is a critical aspect of this procedure. The method is applicable to samples with concentrations of 0.1 to 2.0 mg NO₃-N/l.

Apparatus

Spectrophotometer or filter photometer suitable for measuring absorbance at 410 nm

Sufficient number of 40- to 50-ml glass sample tubes for reagent blanks, standards, and samples

Neoprene-coated wire racks to hold sample tubes

Water bath suitable for use at 100°C. This bath should contain a stirring mechanism so that all tubes are at the same temperature and should be of sufficient capacity to accept the required number of tubes without significant drop in temperature when the tubes are immersed

Water bath suitable for use at 10 to 15°C

Reagents

Distilled water free of nitrite and nitrate is to be used in preparation

Figure 3-16. Handling and storage of samples for nitrate analysis

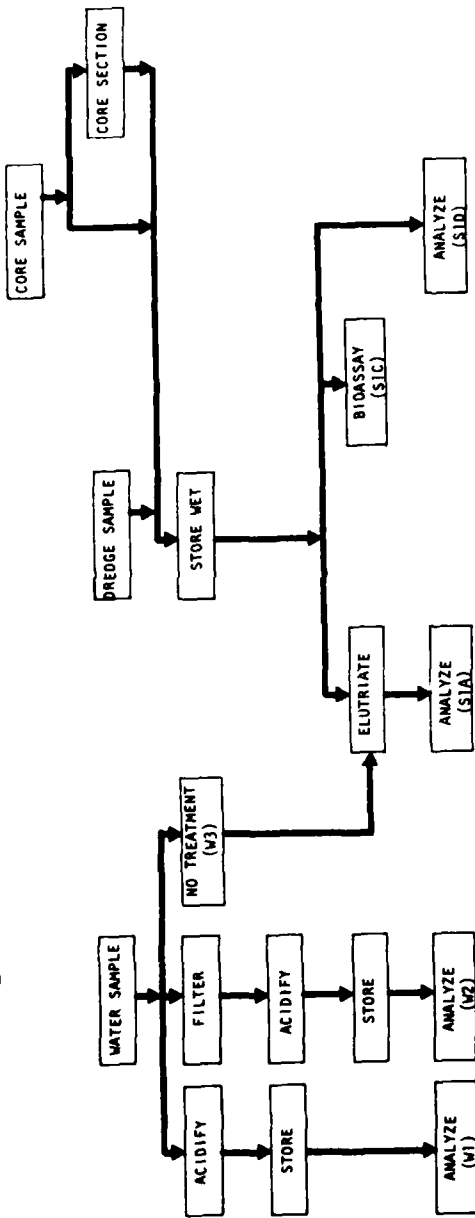

SAMPLE DESIGNATION	W1	W2	W3	S1A	S1C	S1D
PURPOSE	Total Water Conc.	Soluble Water Conc.	Used in Elutriate	Mobile Conc.	Bioavail-ability	Total Sediment Conc.
CONTAINER	G,P	G,P	G,P	G,P	G,P	G,P
SAMPLE TREATMENT	None	Filter	None	None	None	None
PRESERVATIVE	H ₂ SO ₄ pH<2 4°C	H ₂ SO ₄ pH<2 4°C	None	4°C (Minimize Air Contact.)	4°C Keep Field Moist.	4°C
STORAGE TIME	24 hr	24 hr	<1 w	<1 w	<1 w	<1 w
DIGESTION SOLUTION	-	-	-	-	-	Distilled Water
SAMPLE VOLUME OR WEIGHT	20-100 ml	20-100 ml	-	-	-	5-10 g

of all reagents and standards.

Sodium chloride solution (30 percent): dissolve 300 g NaCl in distilled water and dilute to 1 l.

Sulfuric acid solution: carefully add 500 ml conc. H_2SO_4 to 125 ml distilled water. Cool and keep tightly stoppered to prevent absorption of atmospheric moisture.

Brucine-sulfanilic acid reagent: dissolve 1 g Brucine Sulfate $(C_{23}H_{26}N_2O_4)_2 \cdot H_2SO_4 \cdot 7H_2O$ and 0.1 g sulfanilic acid $(NH_2C_6H_4SO_3H \cdot H_2O)$ in 70 ml hot distilled water. Add 3 ml conc. HCl, cool, mix, and dilute to 100 ml with distilled water. Store in a dark bottle at $5^\circ C$. This solution is stable for several months; the pink color that develops slowly does not affect its usefulness. Mark bottle with warning: CAUTION: Brucine Sulfate is toxic; take care to avoid ingestion.

Potassium nitrate stock solution: 1.0 ml = 0.1 mg NO_3-N . Dissolve 0.7218 g anhydrous potassium nitrate, KNO_3 , in distilled water and dilute to 1 l in a volumetric flask. Preserve with 2 ml chloroform per liter. This solution is stable for at least 6 months.

Potassium nitrate standard solution: 1.0 ml = 0.001 mg NO_3-N . Dilute 10.0 ml of the stock solution to 1 l in a volumetric flask. This standard solution should be prepared fresh weekly.

Acetic acid (1 + 3): dilute 1 volume glacial acetic acid (CH_3COOH) with 3 volumes of distilled water.

Sodium hydroxide (1 N): dissolve 40 g of NaOH in distilled water. Cool and dilute to 1 l.

Procedure

Adjust the pH of the samples to approximately 7 with acetic acid or sodium hydroxide. If necessary, filter to remove turbidity.

Set up the required number of sample tubes in the rack to handle reagent blank, standards, and samples. Space tubes evenly throughout the rack to allow for even flow of bath water between the tubes. This should assist in achieving uniform heating of all tubes.

Pipet 10.0 ml of standards and samples or an aliquot of the samples diluted to 10.0 ml into the sample tubes.

Pipet 10.0 ml sulfuric acid solution into each tube and mix by swirling. Place samples and standards in a cold water bath (0 to $10^\circ C$) and do not continue until all samples have reached temperature equilibrium.

Add 0.5 ml brucine-sulfanilic acid reagent to each tube and

carefully mix by swirling. Place samples in a 100°C water bath for exactly 25 min.

Remove rack of tubes from the hot water bath and immerse in the cold water bath and allow to reach thermal equilibrium (20° to 25°C).

Read absorbance against the reagent blank at 410 nm using a 1-cm or longer cell.

CAUTION: The procedure is sensitive to temperature, ionic strength, and color effects of interferences. The following procedures should be followed when appropriate:

- a. Immersion of the tube rack into the bath should not decrease the temperature of the bath more than 1° to 2°C. In order to keep this temperature decrease to an absolute minimum, flow of bath water between the tubes should not be restricted by crowding too many tubes into the rack. If color development in the standards reveals discrepancies in the procedure, the operator should repeat the procedure after reviewing the temperature control steps.
- b. If samples are saline, the ionic strength is buffered prior to acidification of the samples. Add 2 ml 30 percent sodium chloride solution to the reagent blank, standards, and samples. Mix by swirling and place samples in the cold water bath (0° to 10°C). This step is not necessary for freshwater samples.
- c. Samples that are colored or contain dissolved organic matter that can cause the sample to become colored on heating must be run in duplicate. These samples are colorimetric blanks and should receive all reagent additions except brucine-sulfanilic acid. They should receive 0.5 ml distilled water to compensate for dilution effects.

Calculations

Obtain a standard curve by plotting the absorbance of standards run by the above procedure against mg NO₃-N/l. (The color reaction does not always follow Beer's law.) Subtract the absorbance of the sample without the brucine-sulfanilic reagent from the absorbance of the sample containing brucine-sulfanilic acid and determine mg NO₃-N/l. Multiply by an appropriate dilution factor if less than 10 ml of sample is taken.

Method 2: Colorimetric, Automated, Cadmium Reduction

The procedure is applicable to the quantification of either nitrite singly or nitrate plus nitrite combined. Nitrate is reduced in a cadmium reduction column and the total nitrite (original nitrite plus reduced nitrate) is diazotized and coupled with naphthyl-ethylenediamine dihydrochloride. The azo dye that is formed is then quantified colorimetrically.

Nitrite can be determined separately by omitting the cadmium reduction step. Nitrate can then be calculated by running the sample a second time using the cadmium reduction column and subtracting the nitrite concentration from the combined nitrate-nitrite concentration.

It is necessary to continually monitor the performance of the reduction column. This is accomplished by running nitrate and nitrite standards of equal concentration. When discrepancies occur (nitrate standard less than nitrite standard), the column is not operating efficiently and must be replaced.

Samples to be analyzed for nitrate or nitrate plus nitrite must not be preserved with mercuric chloride.

Apparatus

Technicon AutoAnalyzer (AAI or AAI) consisting of the following components:

- a. Sampler
- b. Manifold (AAI) or analytical cartridge (AAI)
- c. Proportioning pump
- d. Colorimeter equipped with a 15- or 50-mm tubular flow cell and 540-nm filters
- e. Recorder
- f. Digital printer for AAI (optional)

Reagents

Granulated cadmium: 40-60 mesh (E. M. Laboratories, Inc., 500 Executive Boulevard, Elmsford, New York 10523; Cat. 2001 Cadmium, Coarse Powder).

Copper-cadmium: the cadmium granules (new or used) are cleaned with dilute HCl and copperized with 2 percent solution of copper sulfate in the following manner:

- a. Wash the cadmium with HCl and rinse with distilled water. The color of the cadmium so treated should be silver.

- b. Swirl 10 g cadmium in 100-ml portions of 2 percent solution of copper sulfate for 5 min or until blue color partially fades; decant and repeat with fresh copper sulfate until a brown colloidal precipitate forms.
- c. Wash the cadmium-copper with distilled water (at least 10 times) to remove all the precipitated copper. The color of the cadmium so treated should be black.

Preparation of reduction column AAI: the reduction column is an 8- by 50-mm glass tube with the ends reduced in diameter to permit insertion into the system. Copper cadmium granules are placed in the column between glass wool plugs. The packed reduction column is placed in an upflow 20-deg incline to minimize channeling. See Figure 3-17.

Preparation of reduction column AAI: the reduction column is a U-shaped, 35-cm-long, 2-mm-I.D. glass tube (see NOTE). Fill the reduction column with distilled water to prevent entrapment of air bubbles during the filling operations. Transfer the copper-cadmium granules to the reduction column and place a glass wool plug in each end. To prevent entrapment of air bubbles in the reduction column, be sure that all pump tubes are filled with reagents before putting the column into the analytical system.

NOTE: A 0.081-in.-I.D. pump tube (purple) can be used in place of the 2-mm glass tube.

Distilled water: because of possible contamination, this should be prepared by passage through an ion exchange column comprised of a mixture of both strongly acidic-cation and strongly basic-anion exchange resins. The regeneration of the ion exchange column should be carried out according to the manufacturer's instructions.

Color reagent: to approximately 800 ml of distilled water, add, while stirring, 100 ml conc. phosphoric acid, 40 g sulfanilimide, and 2 g N-1-naphthyl-ethylenediamine dihydrochloride. Stir until dissolved and dilute to 1 l. Store in brown bottle and keep in the dark when not in use. This solution is stable for several months.

Dilute hydrochloric acid, 6 N: dilute 50 ml of conc. HCl to 100 ml with distilled water.

Copper sulfate solution, 2 percent: dissolve 20 g of $\text{CuSO}_4 \cdot 5\text{H}_2\text{O}$ in 500 ml of distilled water and dilute to 1 l.

Wash solution: use distilled water for unpreserved samples. For samples preserved with H_2SO_4 , use 2 ml H_2SO_4 per liter of wash water.

Ammonium chloride-EDTA solution: dissolve 85 g of reagent grade ammonium chloride and 0.1 g of disodium ethylenediamine

Figure 3-17. Copper cadmium reduction column

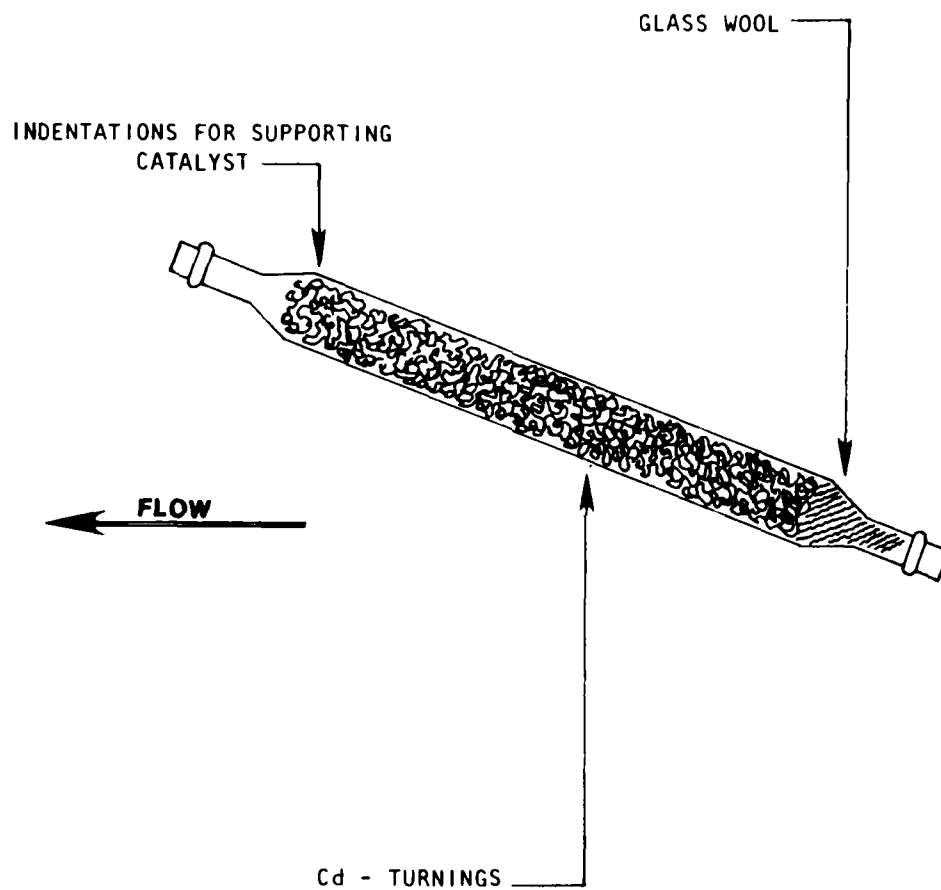

TILT COLUMN TO 20° POSITION

tetracetate in 900 ml of distilled water. Adjust the pH to 8.5 with conc. ammonium hydroxide and dilute to 1 ℓ. Add 0.5 ml Brij-35 (available from Technicon Corporation).

Stock nitrate solution: dissolve 7.218 g KNO₃ and dilute to 1 ℓ in a volumetric flask with distilled water. Preserve with 2 ml of chloroform per liter. Solution is stable for 6 months. 1 ml = 1.0 mg NO₃-N.

Stock nitrite solution: dissolve 6.072 g KNO₂ in 500 ml of distilled water and dilute to 1 ℓ in a volumetric flask. Preserve with 2 ml of chloroform and keep under refrigeration. 1.0 ml = 1.0 mg NO₂-N.

Standard nitrate solution: dilute 10.0 ml of stock nitrate solution to 1000 ml. 1.0 ml = 0.01 mg NO₃-N. Preserve with 2 ml of chloroform per liter. Solution is stable for 6 months.

Standard nitrite solution: dilute 10.0 ml of stock nitrite solution to 1000 ml. 1.0 ml = 0.01 mg NO₂-N. Solution is unstable; prepare as required.

Using standard nitrate solution, prepare the following standards in 100-ml volumetric flasks. At least one nitrite standard should be compared to a nitrate standard at the same concentration to verify the efficiency of the reduction column.

<u>Conc. mg NO₃-N or NO₂-N</u>	<u>ml Standard Solution/100 ml</u>
0.00	0
0.05	0.5
0.10	1.0
0.20	2.0
0.50	5.0
1.00	10.0
2.00	20.0
4.00	40.0
6.00	60.0

NOTE: When the samples to be analyzed are saline waters, Substitute Ocean Water (SOW) should be used for preparing the standards; otherwise, distilled water is used. A tabulation of SOW composition follows:

NaCl - 24.53 g/ℓ	MgCl ₂ - 5.20 g/ℓ	Na ₂ SO ₄ - 4.09 g/ℓ
CaCl ₂ - 1.16 g/ℓ	KCl - 0.70 g/ℓ	NaHCO ₃ - 0.20 g/ℓ
KBr - 0.10 g/ℓ	H ₃ BO ₃ - 0.03 g/ℓ	SrCl ₂ - 0.03 g/ℓ
NaF - 0.003 g/ℓ		

Procedure

Adjust the sample pH between 5 and 9 using either conc. HCl or conc. NH₄OH.

Set up the manifold as shown in Figure 3-18 for an AAI

Figure 3-18. AAI manifold for nitrate determination following cadmium reduction

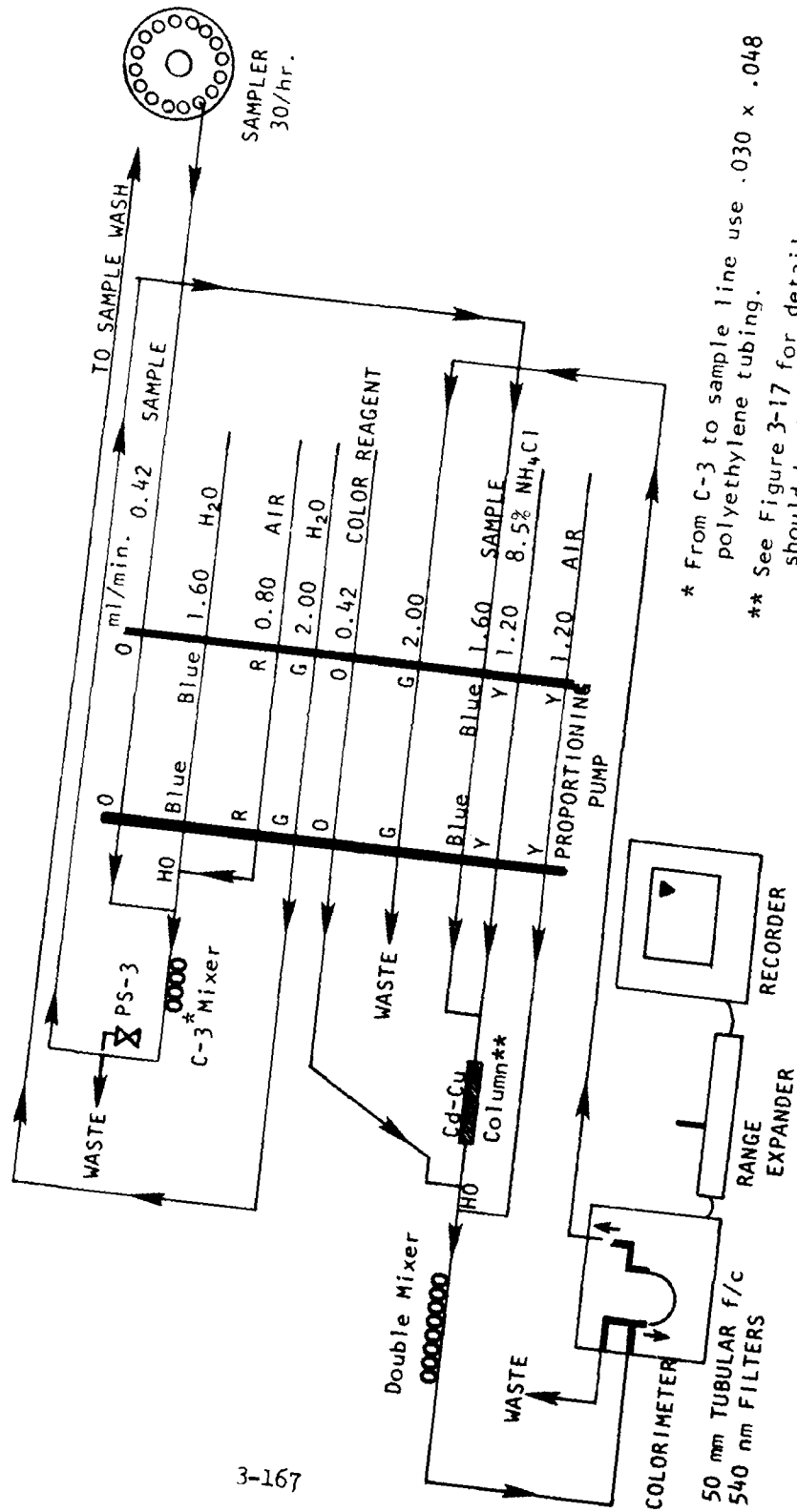

or Figure 3-19 for an AAI. Take care not to introduce air into the reduction column of the AAI during set up and initial operation. If the AAI option is selected, be sure to incline the reductant column at approximately 20 deg with flow from bottom to top.

Allow both colorimeter and recorder to warm up for 30 min. Obtain a stable baseline with all reagents, feeding distilled water through the sample line.

NOTE: Condition column by running 1 mg/l nitrate standard for 10 min if a new reduction column is being used. Subsequently wash the column with reagents for 20 min.

Place appropriate nitrate and/or nitrite standards in sampler in order of decreasing concentration of nitrogen. Complete loading of sampler tray with unknown samples. For the AAI system, sample at a rate of 30/hr, 1:1 cam and a common wash. For the AAI, use a 40/hr, 4:1 cam and a common wash.

Switch sample line to sampler and start analysis.

Calculations

Prepare appropriate standard curve or curves derived from processing NO_2 and/or NO_3 standards through manifold. Compute concentration of samples by comparing sample peak heights with standard curve.

Method 3: Colorimetric, Automated, Hydrazine Reduction⁷

The only major difference between this method and Method 2, Cadmium Reduction, is the reducing agent used to reduce nitrate to nitrite. Hydrazine sulfate is used in place of the cadmium reduction column with this procedure. The total nitrite (original nitrite plus reduced nitrate) is then diazotized and determined colorimetrically as before. The method is applicable to a combined nitrate-nitrite concentration of 0.01 to 10 mg N/l.

Nitrite can be determined separately by omitting the use of hydrazine sulfate. Nitrate can then be calculated by subtracting the nitrite concentration from the combined nitrate-nitrite concentration.

Apparatus

Sampler

Manifold AAI or AAI

Figure 3-19. AAII cartridge for the determination of nitrate following cadmium reduction

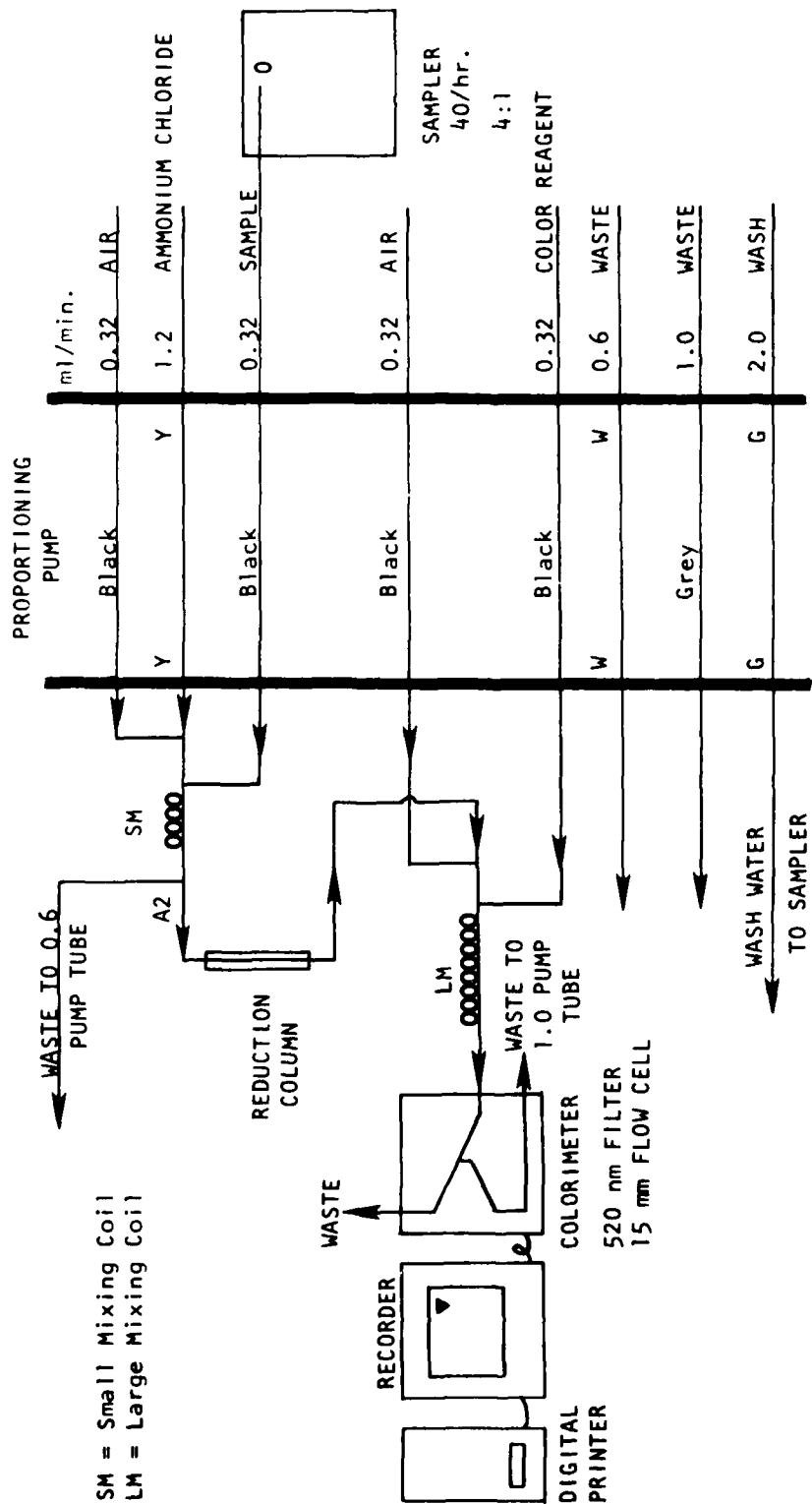

Proportioning pump

Heating bath 32°C AAI or 37°C AAI

Continuous filter

Colorimeter equipped with an 8-, 15-, or 50-mm flow cell and 529-nm filters

Reagents

Color development reagent: to approximately 500 ml of distilled water add 200 ml concentrated phosphoric acid (sp. gr. 1.834), 10 g sulfanilamide ($\text{H}_2\text{NC}_6\text{H}_4\text{SO}_2\text{NH}_2$), followed by 0.8 g N (1-Naphthyl) ethylenediamine dihydrochloride. Dilute the solution to 1 l with distilled water and store in a dark bottle in the refrigerator. This solution is stable for approximately 1 month.

Copper sulfate stock solution: dissolve 2.5 g of copper sulfate ($\text{CuSO}_4 \cdot 5\text{H}_2\text{O}$) in distilled water and dilute to 1 l.

Copper sulfate dilute solution: dilute 20 ml of stock solution to 2 l with distilled water.

Sodium hydroxide stock solution (10 N): dissolve 400 g NaOH in 750 ml distilled water, cool, and dilute to 1 l.

Sodium hydroxide (1.0 N): dilute 100 ml of stock NaOH solution to 1 l.

Hydrazine sulfate stock solution: dissolve 27.5 g of hydrazine sulfate ($\text{N}_2\text{H}_4 \cdot \text{H}_2\text{SO}_4$) in 900 ml of distilled water and dilute to 1 l. This solution is stable for approximately 6 months.

Mark container with appropriate warning: CAUTION: Toxic if ingested.

Hydrazine sulfate dilute solution:

a. When using an AAI, dilute 55 ml stock hydrazine sulfate to 1 l with distilled water.

b. When using an AAI, dilute 22 ml stock hydrazine sulfate to 1 l with distilled water.

Stock nitrate solution (100 mg/l $\text{NO}_3\text{-N}$): dissolve 0.7218 g of KNO_3 , oven dried at 100° to 105°C for 2 hr, in distilled water and dilute to 1 l. Add 1 ml chloroform as a preservative. Solution is stable for approximately 6 months. 1 ml = 0.1 mg N.

Stock nitrite solution (100 mg/l $\text{NO}_2\text{-N}$): dissolve 0.6072 g KNO_2 in 500 ml of distilled water and dilute to 1 l. Preserve with 2 ml of chloroform and keep under refrigeration. 1 ml = 0.1 mg N.

Standard nitrate solution: dilute 100 ml of stock nitrate solution to 1 l. 1 ml = 0.01 mg N.

Using the stock nitrate solution, prepare the standards on the following page in 100-ml volumetric flasks. At least one nitrite standard should be compared to a nitrate standard at the concentration to verify the efficiency of the reduction.

<u>ml of Stock Solution/100 ml</u>	<u>Conc., mg NO₃-N/l</u>
0.5	0.5
1.0	1.0
2.0	2.0
3.0	3.0
4.0	4.0
5.0	5.0
8.0	8.0
10.0	10.0

Procedure

Set up the appropriate manifold as suggested in either Figure 3-20 (AII) or Figure 3-21 (AAI). Both procedures require the use of a continuous filter to remove precipitate that will interfere with the colorimetric procedure.

Allow both colorimeter and recorder to warm up for 30 min. Obtain a stable baseline with all reagents, feeding distilled water through the sample line.

Run a 2.0-mg/l NO₃-N and a 2.0-mg/l NO₂-N standard through the system to check for 100 percent reduction of nitrate to nitrite. The two peaks should be of equal height. If they are not, the concentration of the hydrazine sulfate solution must be adjusted as follows. If the NO₃ peak is lower than that of the NO₂ peak, the concentration of hydrazine sulfate should be increased until they are equal. If the NO₃ peak is higher than the nitrite, the concentration of the hydrazine sulfate should be reduced. When the correct concentration of hydrazine sulfate has been determined, no further adjustment should be necessary.

Place standards in the sample tray in order of decreasing concentration. Complete loading of tray with samples.

Process samples at the rate of 30/hr.

Calculations

Prepare a standard curve by plotting peak heights of processed standards against known concentrations. Compute concentrations of samples by comparing sample peak heights with the standard curve.

Figure 3-20. AAI manifold for the determination of nitrate following hydrazine reduction

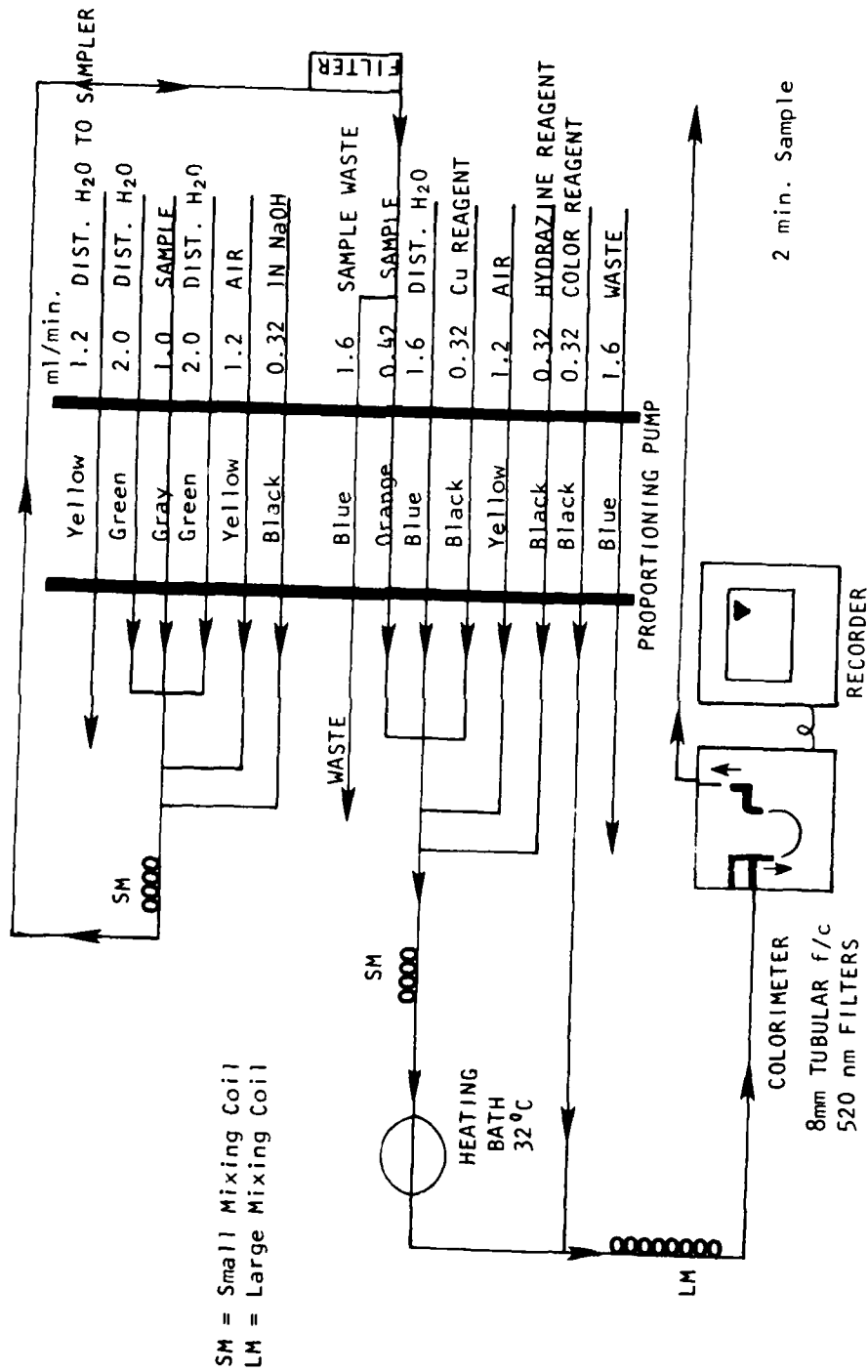
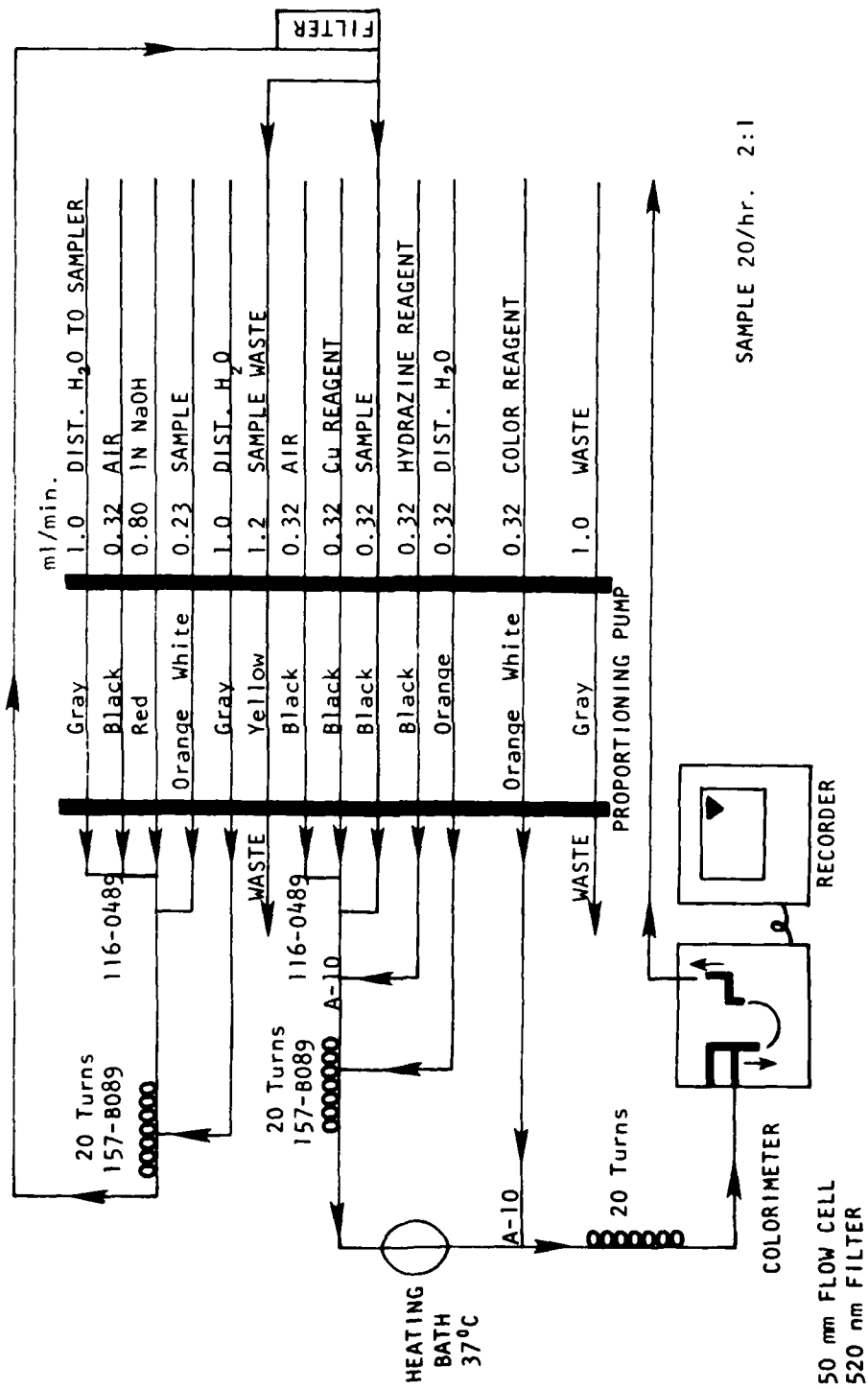

Figure 3-21. AAII cartridge for the determination of nitrate following hydrazine reduction



Method 4: Colorimetric, Manual, Cadmium Reduction⁷

This procedure is similar to Method 2 except that the samples are processed manually rather than automatically. The same uses and cautions, therefore, apply to this method.

Samples to be analyzed for nitrate or nitrate plus nitrite must not be preserved with mercuric chloride as it poisons the cadmium reduction column.

Apparatus

Reduction column: the column in Figure 3-22 was constructed from a 100-ml pipet by removing the top portion. This column may also be constructed from two pieces of tubing joined end to end. A 10-cm length of 3-cm-I.D. tubing is joined to a 25-cm length of 3.5-cm-I.D. tubing.

Spectrophotometer for use at 540 nm, providing a light path of 1 cm or longer.

Reagents

Granulated cadmium: 40 to 60 mesh (E. M. Laboratories, Inc., 500 Executive Boulevard, Elmsford, New York 10523; Cat. 2001 Cadmium, Coarse Powder).

Copper-Cadmium: the cadmium granules (new or used) are cleaned with dilute HCl and copperized with 2 percent solution of copper sulfate in the following manner:

- a. Wash the cadmium with dilute HCl and rinse with distilled water. The color of the cadmium should be silver.
- b. Swirl 25 g cadmium in 100-ml portions of a 2 percent solution of copper sulfate for 5 min or until blue color partially fades; decant and repeat with fresh copper sulfate until a brown colloidal precipitate forms.
- c. Wash the copper-cadmium with distilled water (at least 10 times) to remove all the precipitated copper. The color of the cadmium so treated should be black.

Preparation of reaction column: insert a glass wool plug into the bottom of the reduction column and fill with distilled water. Add sufficient copper-cadmium granules to produce a column 18.5 cm in length. Maintain a level of distilled water above the copper-cadmium granules to eliminate entrapment of air. Wash the column with 200 ml of dilute ammonium chloride solution. The column is then activated by passing through the column 100 ml of a solution composed of 25 ml of a 1.0-mg/l $\text{NO}_3\text{-N}$ standard and 75 ml of ammonium chloride-EDTA solution. Use a flow rate between 7 and 10 ml/min.

Ammonium chloride-EDTA solution: dissolve 13 g ammonium chloride and

Figure 3-22. Nitrate reduction column

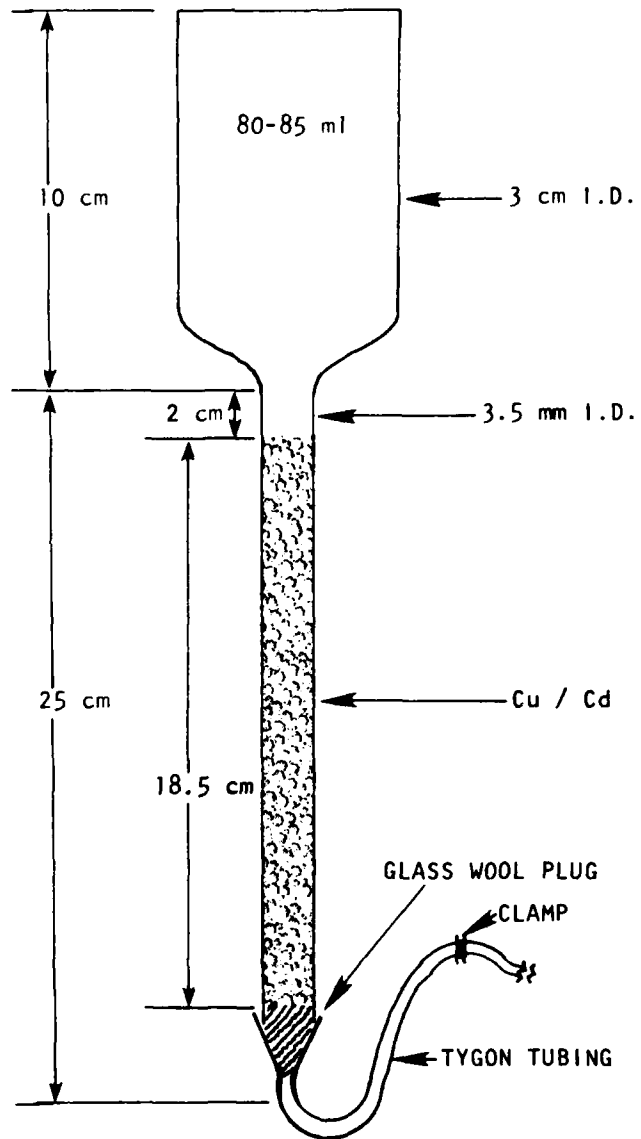

1.7 g disodium ethylenediamine tetracetate in 900 ml of distilled water. Adjust the pH to 8.5 with conc. ammonium hydroxide and dilute to 1 l.

Dilute ammonium chloride-EDTA solution: dilute 300 ml of ammonium chloride-EDTA solution to 500 ml with distilled water.

Color reagent: dissolve 10 g sulfanilamide and 1 g N (1-naphthyl)-ethylenediamine dihydrochloride in a mixture of 100 ml conc. phosphoric acid and 800 ml of distilled water and dilute to 1 l with distilled water.

Zinc sulfate solution: dissolve 100 g $ZnSO_4 \cdot 7H_2O$ in distilled water and dilute to 1 l.

Sodium hydroxide solution, 6 N: dissolve 240 g NaOH in 500 ml distilled water, cool, and dilute to 1 l.

Ammonium hydroxide, conc.

Dilute hydrochloric acid, 6 N: dilute 50 ml of conc. HCl to 100 ml with distilled water.

Copper sulfate solution, 2 percent: dissolve 20 g of $CuSO_4 \cdot 5H_2O$ in 500 ml of distilled water and dilute to 1 l.

Stock nitrate solution: dissolve 7.218 g KNO_3 in distilled water and dilute to 1000 ml. Preserve with 2 ml of chloroform per liter. This solution is stable for at least 6 months. 1.0 ml = 1.00 mg NO_3-N .

Standard nitrate solution: dilute 10.0 ml of nitrate stock solution to 1000 ml with distilled water. 1.0 ml = 0.01 mg NO_3-N .

Stock nitrite solution: dissolve 6.072 g KNO_2 in 500 ml of distilled water and dilute to 1000 ml. Preserve with 2 ml of chloroform and keep under refrigeration. This solution remains stable for approximately 3 months. 1.0 ml = 1.00 mg NO_2-N .

Standard nitrite solution: dilute 10.0 ml of stock nitrite solution to 1000 ml with distilled water. 1.0 ml = 0.01 mg NO_2-N .

Using standard nitrate solution prepare the following standards in 100-ml volumetric flasks:

<u>Conc., mg-NO_3-N/l</u>	<u>ml of Standard Solution/100.0 ml</u>
0.00	0.0
0.05	0.5
0.10	1.0
0.20	2.0
0.50	5.0
1.00	10.0

Procedure

The presence of turbidity or suspended solids can affect the operation of the nitrate reduction column. This material should

be removed by one of the following methods:

- a. Filter sample through a glass fiber or a 0.45- μ membrane filter.
- b. Add 1 ml zinc sulfate solution to 100 ml of sample and mix thoroughly. Add 0.4 to 0.5 ml sodium hydroxide solution to obtain a pH of 10.5 as determined with a pH meter. Let the treated sample stand a few minutes to allow the heavy flocculent precipitate to settle. Clarify by filtering through a glass fiber filter or a 0.45- μ membrane filter.

If oil or grease is known or thought to be present, it should be removed by extraction. Adjust the pH of 100-ml filtered sample to 2 with conc. HCl. Extract the oil and grease with two 25-ml portions of freon (or chloroform).

Adjust the pH of the sample between 5 and 9 using either conc. HCl or conc. NH_4OH . To a 25-ml sample, or an aliquot diluted to 25 ml, add 75 ml ammonium chloride-EDTA solution and mix. The sample pH should be 8.5.

Pour the sample into the column and adjust the flow to 7 to 10 ml per minute. Discard the first 25 ml of sample and collect the remainder of the sample in the original sample flask.

NOTE: The sample obtained from the column should not be held more than 15 min prior to color development to minimize nitrite oxidation.

To 50 ml of reduced sample, add 2.0 ml color reagent. The color requires 10 min for development and is stable for 2 hr. Measure the sample absorbance at 540 nm relative to a reagent blank.

NOTE: If the sample concentration exceeds 1.0 mg $\text{NO}_3\text{-N/l}$, the remainder of the reduced sample should be appropriately diluted. Develop the color as indicated above and record the sample absorbance.

Standards should be treated the same as samples throughout the entire procedure. In addition, at least one nitrite standard should be compared to a reduced nitrate standard at the same concentration to verify the efficiency of the reduction column.

Calculations

Prepare a standard curve by plotting the absorbance of standards against the nitrate and/or nitrite concentration. Compute sample concentration by comparing sample absorbance with the standard

curve.

If less than 25 ml of sample is used for the analysis, the following equation should be used:

$$\text{mg NO}_2 + \text{NO}_3\text{-N/l} = \frac{A \times 25}{\text{ml sample used}}$$

where

A = concentration of nitrate from standard curve

NITROGEN
(Nitrite)

Sample Collection and Storage

Handling and storage requirements for nitrite samples are the same as nitrate samples. Samples may be collected and stored in either glass or plastic containers. Environmental Protection Agency manuals^{1,7} suggest that sulfuric acid can be used as a preservative for nitrite in water. However, soils literature⁵ suggest that acid can cause the conversion of nitrite. It is recommended that water samples be maintained at 4°C with minimum atmospheric contact. Samples should be processed as soon as possible. The volume of sample required will range from 20 to 100 ml depending on whether an automated or manual method is used (Figure 3-2).

Nitrite may be determined using Methods 2, 3, or 4 in the Nitrate-Nitrogen section (Nitrite Methods 1, 2, and 3). The only alteration of these procedures is to omit the use of the reduction column or the reducing agent and to use nitrite standards rather than nitrate standards.

Procedures for Water Samples (W1, W2, S1A)

Method 1: See Nitrate Method 2, Colorimetric, Automated, Cadmium Reduction.¹

Omit use of cadmium reduction column and proceed as indicated.

Method 2: See Nitrate Method 3, Colorimetric, Automated, Hydrazine Reduction.¹

Omit use of hydrazine sulfate and proceed as indicated.

Method 3: See Nitrate Method 4, Colorimetric, Manual, Cadmium Reduction.¹

Omit use of cadmium reduction column and proceed as indicated.

Method 4: Colorimetric, Manual¹

This procedure is a manual adaptation of Method 1. Nitrite is diazotized and coupled with naphthyl-ethylenediamine dihydrochloride

Figure 3-23. Handling and storage of samples for nitrite analysis

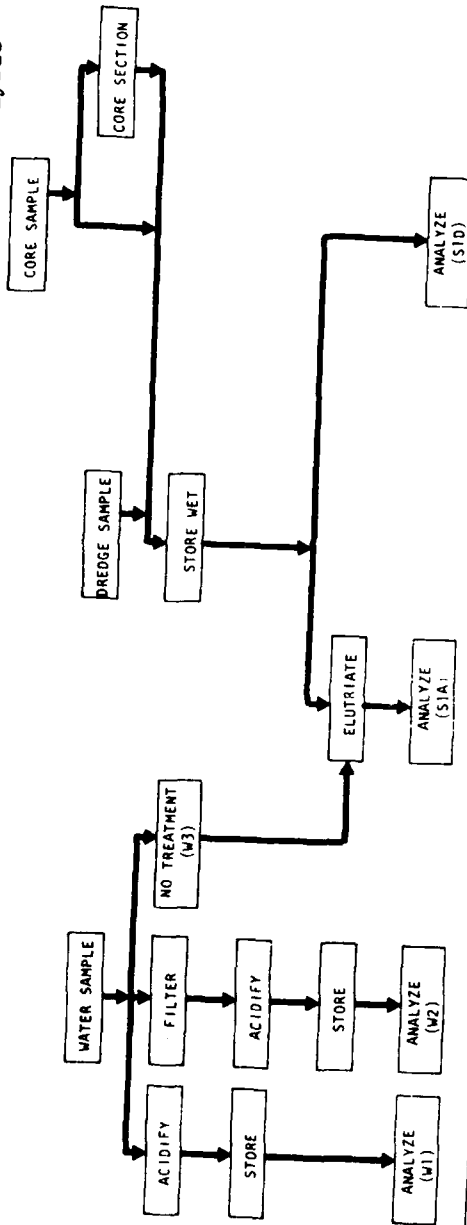

3-180

SAMPLE DESIGNATION	W1	W2	W3	SIA	SID
PURPOSE	Total Water Conc.	Soluble Water Conc.	Used In Elutriate	Mobile Conc.	Total Sediment Conc.
CONTAINER	G,P	G,P	G,P	G,P	G,P
SAMPLE TREATMENT	None	Filter	None	None	None
PRESERVATIVE	H ₂ SO ₄ pH<2 4°C	H ₂ SO ₄ pH<2 4°C	None	4°C (Minimize Air Contact. Keep Field Moist.)	4°C
STORAGE TIME	48 hr	48 hr	<1 w	<1 w	<1 w
DIGESTION SOLUTION	-	-	-	-	Distilled Water
SAMPLE VOLUME OR WEIGHT	20-100 ml	20-100 ml	-	20-100 ml	5-10 g

to produce a reddish-purple dye. The sample absorbance is then measured colorimetrically.

Apparatus

Spectrophotometer equipped with 1 cm or larger cells for use at 540 nm
Nessler tubes, 50 ml, or volumetric flasks, 50 ml

Reagents

Distilled water free of nitrite and nitrate is to be used in preparation of all reagents and standards.

Buffer-color reagent: to 250 ml of distilled water, add 105 ml conc. hydrochloric acid, 5.0 g sulfanilamide, and 0.5 g N (1-naphthyl) ethylenediamine dihydrochloride. Stir until dissolved. Add 136 g of sodium acetate, $\text{CH}_3\text{COONa} \cdot 3 \text{H}_2\text{O}$, and again stir until dissolved. Dilute to 500 ml with distilled water. This solution is stable for several weeks if stored in the dark.

Nitrite stock solution: 1.0 ml = 0.10 mg $\text{NO}_2\text{-N}$. Dissolve 0.4926 g of dried anhydrous sodium nitrite (24 hr in desiccator) in distilled water and dilute to 1000 ml. Preserve with 2 ml chloroform per liter.

Nitrite standard solution: 1.0 ml = 0.001 mg $\text{NO}_2\text{-N}$. Dilute 10.0 ml of the stock solution to 1000 ml.

Procedure

If the sample has a pH greater than 10 or a total alkalinity greater than 600 mg/l, adjust the sample pH to 6 with the addition of 1:3 HCl.

Filter the sample, if necessary, through a 0.45- μ pore-size filter to remove suspended solids and turbidity.

Place 50 ml of sample, or an aliquot diluted to 50 ml, in a 50-ml Nessler tube. Do not process samples further until the nitrite standards are ready.

Prepare a series of nitrite standards as suggested below:

ml of Standard Solution 1.0 ml = 0.001 mg $\text{NO}_2\text{-N}$	Conc., When Diluted to 50 ml, mg/l of $\text{NO}_2\text{-N}$
0.0	(Blank)
0.5	0.01
1.0	0.02
1.5	0.03
2.0	0.04
3.0	0.06
4.0	0.08
5.0	0.10
10.0	0.20

Add 2 ml of buffer color reagent to each sample and standard. Mix and allow 15 min for color development. The resultant solution should have a pH between 1.5 and 2.0.

Measure the absorbance of the sample at 540 nm relative to the blank.

Calculations

Prepare a standard curve by plotting standard nitrite concentration versus absorbance. Compare the measured sample absorbance to the standard curve to determine the sample nitrite concentration.

If a sample aliquot is diluted to 50 ml, calculate the nitrite concentration as follows:

$$\text{NO}_2\text{-N, mg/l} = \frac{\text{mg/l from standard curve} \times 50}{\text{ml sample used}}$$

Procedure for Sediment Samples (SID)

This procedure for nitrate plus nitrite consists of heating the sediment slurry and then centrifuging out the solids. The liquid phase is then analyzed for nitrate plus nitrite. This separation procedure is based on the high solubility of nitrates and nitrites but should be considered operationally defined. The apparatus and reagents will depend upon which of the methods listed in the nitrate and nitrite sections for water analysis is used.

Procedure

Weigh a 0.5- to 1.0-g sample of the wet sediment. Transfer to a 200-ml Erlenmeyer flask and add 50 ml distilled water and 3 to 4 drops of conc. sulfuric acid. This treatment will preserve the sample for 24 hr if necessary.

Add 50 ml distilled water to the acidified slurry and boil the sample for 15 min. Since the procedure is operationally defined, the heating time should be standardized for all samples.

Transfer the sample to a centrifuge tube and centrifuge the slurry at 2000 rpm for 5 to 10 min. Decant the liquid phase into a 200-ml volumetric flask.

Add 50 ml distilled water to the solids in the centrifuge tube and thoroughly mix the sample. Centrifuge for 5 to 10 min at 2000 rpm. Decant the wash into the volumetric flask.

Repeat the washing procedure a second time and add the wash to the volumetric flask. Dilute the sample to volume with distilled water. Filter the sample through a 0.45- μ pore-size membrane filter.

Analyze the sample using one of the nitrate plus nitrite procedures in the water analysis section. If it is necessary to know the nitrate concentration, the sample should be analyzed twice: once for nitrate plus nitrite using the cadmium reduction column or the hydrazine reduction method, and a second time for nitrite by omitting the use of the cadmium reduction column or hydrazine sulfate. Nitrate can then be calculated by subtraction.

If the sample is to be analyzed for nitrate with the Brucine method, the salt modification recommended for use with seawater samples should be used to correct for the high salt concentration that may be leached from the sediment samples.

Calculations

Determine the nitrate plus nitrite concentration of the sample leachate using the appropriate standard curve. Calculate the nitrate plus nitrite concentration of the sediment sample as follows:

$$\text{nitrate + nitrite mg N/kg (wet basis)} = \frac{(x)(y)(1000)}{g}$$

where

x = nitrate plus nitrite concentration in sample, mg/l

y = sample volume, l (0.2 l as described)

g = wet weight of sediment sample, g

$$\text{nitrate + nitrite mg N/kg (dry basis)} = \frac{(x)(y)(1000)}{(g)(\% S)}$$

where

x = nitrate plus nitrite concentration in sample, mg/l

y = sample volume, l (0.2 l as described)

g = wet weight of sediment sample, g

% S = percent solids in sediment (as decimal fraction)

NITROGEN
(Total Kjeldahl)

Sample Collection and Storage

Total Kjeldahl nitrogen (TKN) samples may be collected and held in either glass or plastic containers. Samples may be preserved with sulfuric acid (pH < 2) at 4°C and should be analyzed within 24 hr. Longer storage times have been reported at high TKN concentrations. A flowchart for sample handling is presented in Figure 3-24.

Procedures for Water Samples (W1, W2, S1A)

Method 1: Colorimetric, Semiautomated with Block Digestor^{1,8,9}

The procedure consists of two parts. The sample is initially digested with a sulfuric acid-potassium sulfate-mercury sulfate solution to convert organic nitrogen to ammonia. The sample is then analyzed for total ammonia (original ammonia plus covered organic nitrogen). The applicable range is 0.1 to 20 mg TKN-N/l.

Apparatus

Block digester-40 and digestion tubes

Technicon manifold for ammonia (Figure 3-25)

Chemware TFE (Teflon boiling stones), Markson Science, Inc., Box 767,
Delmar, California 92014

Reagents

Mercuric sulfate: dissolve 8 g red mercuric oxide, HgO, in 50 ml of 1:4 sulfuric acid (10 ml conc. H₂SO₄:40 ml distilled water) and dilute to 100 ml with distilled water.

Digestion solution (sulfuric acid-mercuric sulfate-potassium sulfate solution): dissolve 133 g of K₂SO₄ in 700 ml of distilled water and 200 ml of conc. H₂SO₄. Add 25 ml of mercuric sulfate solution and dilute to 1 l.

Sulfuric acid solution (4 percent): add 40 ml of conc. sulfuric acid to 800 ml of ammonia-free distilled water, cool, and dilute to 1 l.

Stock sodium hydroxide (20 percent): dissolve 200 g of sodium hydroxide in 900 ml of ammonia-free distilled water and dilute to 1 l.

Figure 3-24. Handling and storage of samples for Mn analysis

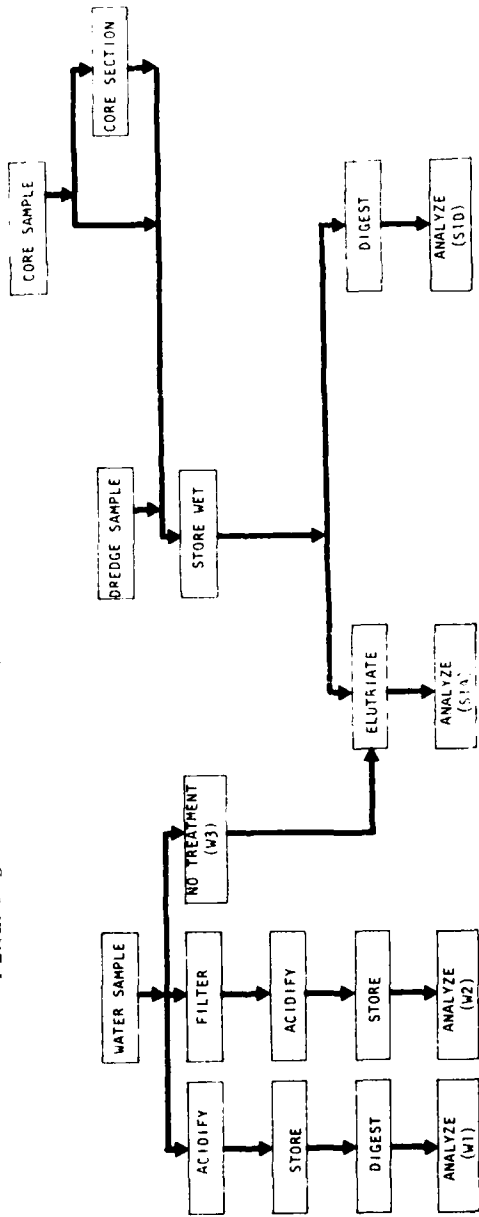

SAMPLE DESIGNATION	W1	W2	W3	S1A	S1D
PURPOSE	Total Water Conc.	Soluble Water Conc.	Used in Elutriate	Mobile Conc.	Total Sediment Conc.
CONTAINER	G,P	G,P	G,P	G,P	G,P
SAMPLE TREATMENT	None	Filter	None	None	None
PRESERVATIVE	H ₂ SO ₄ pH2 4°C	H ₂ SO ₄ pH2 4°C	None	4°C (Minimize Air Contact. Keep Field Moist.)	4°C
STORAGE TIME	24 hr	24 hr	<1 w	<1 w	<1 w
DIGESTION SOLUTION	Hg H ₂ SO ₄ K ₂ SO ₄	Hg H ₂ SO ₄ K ₂ SO ₄		Hg H ₂ SO ₄ K ₂ SO ₄	HgSO ₄ H ₂ SO ₄ K ₂ SO ₄
SAMPLE VOLUME OR WEIGHT	20-500 ml	20-500 ml		20-500 ml	0.5-1.0 g

Figure 3-25. AAI cartridge for ammonia determinations with TKN digests

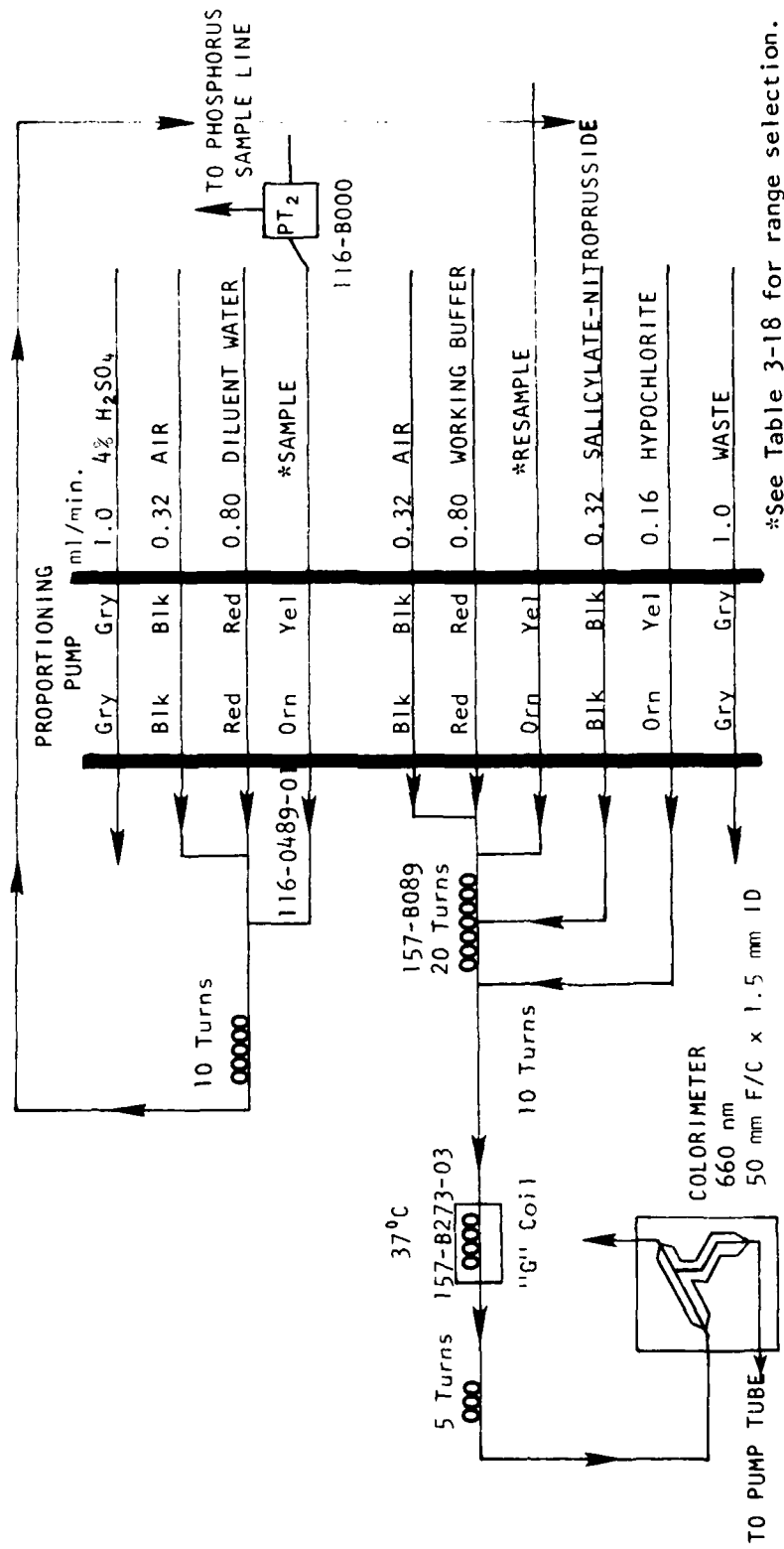

*See Table 3-18 for range selection.

Stock sodium potassium tartrate solution (20 percent): dissolve 200 g potassium tartrate in about 800 ml of ammonia-free distilled water and dilute to 1 l.

Stock buffer solution: dissolve 134.0 g of sodium phosphate, dibasic, Na_2HPO_4 , in about 800 ml of ammonia-free water. Add 20 g of sodium hydroxide and dilute to 1 l.

Working buffer solution: combine the reagents in the stated order; add 250 ml of stock sodium potassium tartrate solution to 200 ml of stock buffer solution and mix. Add xx ml sodium hydroxide solution and dilute to 1 l. The exact volume of sodium hydroxide solution (xx ml) will vary with the expected nitrogen concentration as indicated in the last column in Table 3-13.

Sodium salicylate/sodium nitroprusside solution: dissolve 150 g of sodium salicylate and 0.3 g of sodium nitroprusside in about 600 ml of ammonia-free water and dilute to 1 l.

Sodium hypochlorite solution: dilute 6.0 ml sodium hypochlorite solution (Clorox) to 100 ml with ammonia-free distilled water.

Ammonium chloride, stock solution: dissolve 3.819 g NH_4Cl in distilled water and bring to volume in a 1-l volumetric flask. 1 ml = 1.0 mg $\text{NH}_3\text{-N}$.

Procedure

Transfer 25 ml of sample to a digestion tube and add 5 ml digestion solution. Mix sample with a vortex mixer to avoid superheating during digestion. Add 4 to 5 Teflon boiling stones.

With block digester in manual mode, set low and high temperature at 160°C and preheat unit to 160°C . Place tubes in digester and switch to automatic mode. Set low temperature timer for 1 hr. Reset high temperature to 380°C and set timer for 2-1/2 hr.

Allow ingested samples to cool to room temperature and dilute to 25 ml with ammonia-free water.

Prepare an ammonia manifold as indicated in Figure 3-25. Check all reagent containers to ensure an adequate supply.

Excluding the salicylate line, place all reagent lines in their respective containers, connect the sample probe to the sampler, and start the proportioning pump.

Flush the sampler wash receptacle with approximately 25 ml 4.0 percent sulfuric acid.

When reagents have been pumping for at least 5 min, place the salicylate line in its respective container and allow the system to

Table 3-18
Operating Characteristics for TKN AutoAnalyzer Manifold
CONCENTRATION RANGES
(NITROGEN)

No.	Initial Sample		Dilution Loops		Resample		Approx. std. cal. setting	Range PPM N ($\pm 10\%$)	ml stock NaOH per liter working buffer solution
	Sample Line	Diluent Line	Diluent Line	Resample Line	Resample Line	Diluent Line			
1	.80 (RED/RED)	.80 (RED/RED)	.80 (RED/RED)	.32 (BLK/BLK)	.80 (RED/RED)	.80 (RED/RED)	700	0-0.5	250
2	.80 (RED/RED)	.80 (RED/RED)	.80 (RED/RED)	.32 (BLK/BLK)	.80 (RED/RED)	.80 (RED/RED)	100	0-1.5	250
3	.16 (ORN/YEL)	.80 (RED/RED)	.80 (RED/RED)	.32 (BLK/BLK)	.80 (RED/RED)	.80 (RED/RED)	700	0-1	120
4	.16 (ORN/YEL)	.80 (RED/RED)	.80 (RED/RED)	.32 (BLK/BLK)	.80 (RED/RED)	.80 (RED/RED)	100	0-5	120
5	.16 (ORN/YEL)	.80 (RED/RED)	.80 (RED/RED)	.16 (ORN/YEL)	.80 (RED/RED)	.80 (RED/RED)	700	0-2	80
6	.16 (ORN/YEL)	.80 (RED/RED)	.80 (RED/RED)	.16 (ORN/YEL)	.80 (RED/RED)	.80 (RED/RED)	100	0-10	80

equilibrate. If a precipitate forms after the addition of salicylate, the pH is too low. Immediately stop the proportioning pump and flush the coils with water using a syringe. Before restarting the system, check the concentration of the sulfuric acid solutions and/or the working buffer solution.

To prevent precipitation of sodium salicylate in the waste tray, which can clog the tray outlet, keep the nitrogen flow cell pump and the nitrogen colorimeter "To Waste" tube separate from other lines or keep tap water flowing in the waste tray.

Place ammonia standards in sample tray in order of decreasing concentration. Complete loading of sample tray with digested samples. When a stable baseline has been obtained, switch sample line to sampler and start analysis. Use a 40/hr, 4:1 cam for the AAI.

Calculations

Prepare standard curve by plotting peak heights of processed standards against concentration values. Compute concentrations by comparing sample peak heights with standard curve.

Method 2: Manual Colorimetric, Titrimetric¹⁻⁴

The first step in this method consists of digestion and distillation. Ammonia, both original ammonia and organic nitrogen converted to ammonia, is distilled into a boric acid solution. The ammonia can then be quantitated by nesslerization or sulfuric acid titration. The nesslerization procedure is suitable to ammonia concentrations below 1 mg NH₃-N/ℓ and the titrimetric procedure is suitable to ammonia concentrations above 1 mg NH₃-N/ℓ.

Apparatus

Digestion apparatus: a Kjeldahl digestion apparatus with 800- or 1000-ml flasks and suction takeoff to remove SO₂ fumes and water

Distillation apparatus: the macro Kjeldahl flask is connected to a condenser and an adaptor so that the distillate can be collected. Micro Kjeldahl steam distillation apparatus is commercially available.

Spectrophotometer for use at 400 to 425 nm with a light path of 1 cm or longer

Reagents

Distilled water should be free of ammonia. Such water is best prepared by the passage of distilled water through an ion exchange column containing a strongly acidic cation exchange resin mixed with a strongly basic anion exchange resin. Regeneration of the column should be carried out according to the manufacturer's instructions.

NOTE: All solutions must be made with ammonia-free water.

Mercuric sulfate solution: dissolve 8 g red mercuric oxide, HgO , in 50 ml of 1:4 sulfuric acid (10.0 ml conc. H_2SO_4 :40 ml distilled water) and dilute to 100 ml with distilled water.

Sulfuric acid-mercuric sulfate-potassium sulfate solution: dissolve 267 g K_2SO_4 in 1300 ml distilled water and 400 ml conc. H_2SO_4 . Add 50 ml mercuric sulfate solution and dilute to 2 l with distilled water.

Sodium hydroxide-sodium thiosulfate solution: dissolve 500 g NaOH and 25 g $\text{Na}_2\text{S}_2\text{O}_3 \cdot 5\text{H}_2\text{O}$ in distilled water and dilute to 1 l.

Mixed indicator: mix 2 volumes of 0.2 percent methyl red in 95 percent ethanol with 1 volume of 0.2 percent methylene blue in ethanol. Prepare fresh every 30 days.

Boric acid solution: dissolve 20 g boric acid, H_3BO_3 , in water and dilute to 1 l with distilled water.

Sulfuric acid, standard solution: (0.02 N) 1 ml = 0.28 mg $\text{NH}_3\text{-N}$. Prepare a stock solution of approximately 0.1 N acid by diluting 3 ml of conc. H_2SO_4 (sp. gr. 1.84) to 1 l with CO_2 -free distilled water. Dilute 200 ml of this solution to 1 l with CO_2 -free distilled water. Standardize the approximately 0.02 N acid so prepared against 0.0200 N Na_2CO_3 solution. This last solution is prepared by dissolving 1.060 g anhydrous Na_2CO_3 , oven dried at 140°C , and diluted to 1 l with CO_2 -free distilled water.

NOTE: An alternate and perhaps preferable method is to standardize the approximately 0.1 N H_2SO_4 solution against a 0.100 N Na_2CO_3 solution. By proper dilution, the 0.02 N acid can then be prepared.

Ammonium chloride, stock solution: 1.0 ml = 1.0 mg $\text{NH}_3\text{-N}$. Dissolve 4.319 g NH_4Cl in water and make up to 1 l in a volumetric flask with distilled water.

Ammonium chloride, standard solution: 1.0 ml = 0.01 mg $\text{NH}_3\text{-N}$. Dilute 10.0 ml of the stock solution with distilled water to 1 l in a volumetric flask.

Nessler reagent: dissolve 100 g of mercuric iodide and 70 g potassium iodide in a small volume of distilled water. Add this mixture slowly, with stirring, to a cool solution of 160 g of NaOH in 500 ml of distilled water. Dilute the mixture to 1 l. The solution is stable for at least 1 year if stored in a pyrex bottle out of direct sunlight.

AD-A103 788

STATE UNIV OF NEW YORK COLL AT BUFFALO GREAT LAKES LAB F/G 13/2
PROCEDURES FOR HANDLING AND CHEMICAL ANALYSIS OF SEDIMENT AND W--ETC(11)
MAY 81 R H PLUMB EPA-44-05-5720-10

UNCLASSIFIED

EPA/CE-r1-1

NL

4 OF 6

SEP 2007

A large grid consisting of approximately 10 columns and 10 rows. The majority of the cells in this grid are filled with solid black, obscuring any data that might have been present. Only a few cells in the top-left corner are visible as white space.

Procedure

The distillation apparatus should be presteamed before use by distilling a 1:1 mixture of distilled water and sodium hydroxide-sodium thiosulfate solution until the distillate is ammonia free. This operation should be repeated each time the apparatus is out of service long enough to accumulate ammonia (usually 4 hr or more).

Macro Kjeldahl digestion. Place a measured sample or the residue from the distillation in the ammonia determination (for organic Kjeldahl only) into an 800-ml Kjeldahl flask. The sample size can be determined from the following table:

<u>Kjeldahl Nitrogen in Sample</u> <u>mg/l</u>	<u>Sample Size</u> <u>ml</u>
0 - 5	500
5 - 10	250
10 - 20	100
20 - 50	50.0
50 - 500	25.0

Dilute the sample, if required, to 500 ml with distilled water and add 100 ml sulfuric acid-mercuric sulfate-potassium sulfate solution. Evaporate the mixture in the Kjeldahl apparatus until SO₃ fumes are given off and the solution turns colorless or pale yellow. Continue heating for 30 additional minutes. Cool the residue and add 300 ml distilled water.

Make the digestate alkaline by careful addition of 100 ml of sodium hydroxide-thiosulfate solution without mixing.

NOTE: Slow addition of the heavy caustic solution down the tilted neck of the digestion flask will cause heavier solution to underlay the aqueous sulfuric acid solution without loss of free ammonia. Do not mix until the digestion flask has been connected to the distillation apparatus.

Connect the Kjeldahl flask to the condenser with the tip of the condenser or an extension of the condenser tip below the level of the boric acid solution in the receiving flask.

Distill 30 ml at the rate of 6 to 10 ml/min into 50 ml of 2 percent boric acid contained in a 500-ml Erlenmeyer flask.

Dilute the distillate to 500 ml in the flask. These flasks should be marked at the 350- and the 500-ml volumes. With such

marking, it is not necessary to transfer the distillate to volumetric flasks. For concentrations above 1 mg/l, the ammonia can be determined titrimetrically. For concentrations below this value, it is determined colorimetrically.

Micro Kjeldahl digestion. Place 50.0 ml of sample or an aliquot diluted to 50 ml in a 100-ml Kjeldahl flask and add 10 ml sulfuric acid-mercuric sulfate-potassium sulfate solution.

Evaporate the mixture in the Kjeldahl apparatus until SO₃ fumes are given off and the solution turns colorless or pale yellow. Then digest for an additional 30 min. Cool the residue and add 30 ml distilled water.

Make the digestate alkaline by careful addition of 10 ml of sodium hydroxide-thiosulfate solution without mixing. Do not mix until the digestion flask has been connected to the distillation apparatus.

Connect the Kjeldahl flask to the condenser with the tip of condenser or an extension of the condenser tip below the level of the boric acid solution in the receiving flask or 50-ml short-form Nessler tube.

Steam distill 30 ml at the rate of 6 to 10 ml/min into 5 ml of 2 percent boric acid.

Dilute the distillate to 50 ml. For concentrations above 1 mg/l, the ammonia can be determined titrimetrically. For concentrations below this value, it is determined colorimetrically.

- a. Titrimetric determination: add 3 drops of the mixed indicator to the distillate and titrate the ammonia with the 0.02 N H₂SO₄, matching the endpoint against a blank containing the same volume of distilled water and H₃BO₃ solution.
- b. Colorimetric determination: prepare a series of Nessler tube standards as follows:

ml of Standard	
<u>1.0 ml = 0.01 mg NH₃-N</u>	<u>mg NH₃-N/50.0 ml</u>
0.0	0.0
0.5	0.005
1.0	0.010
2.0	0.020
4.0	0.040
5.0	0.050
8.0	0.080
10.0	0.10

Dilute each tube to 50 ml with ammonia-free water, add 1 ml of Nessler reagent, and mix. After 20 min, read the absorbance at 425 nm against the blank. From the values obtained for the standards, plot absorbance vs. mg NH₃-N for the standard curve. Develop color in the 50-ml diluted distillate in exactly the same manner and read mg NH₃-N from the standard curve.

It is not imperative that all standards be treated in the same manner as the samples. It is recommended that at least two standards (high and low) be digested, distilled, and compared to similar values on the curve to ensure that the digestion-distillation technique is reliable. If treated standards do not agree with untreated standards, the operator should find the cause of the apparent error before proceeding.

Calculations

If the titrimetric procedure is used, calculate total Kjeldahl nitrogen, in mg/l, in the original sample as follows:

$$\text{TKN, mg/l} = \frac{(A - B)N \times F \times 1000}{S}$$

where

A = volume of standard 0.020 N H₂SO₄ solution used in titrating sample, ml

B = volume of standard 0.020 N H₂SO₄ solution used in titrating blank, ml

N = normality of sulfuric acid solution

F = milliequivalent weight of nitrogen (14 mg)

S = volume of sample digested, ml

If the Nessler procedure is used, calculate the total Kjeldahl nitrogen, in mg/l, in the original sample as follows:

$$\text{TKN, mg/l} = \frac{A \times 1000}{D} \times \frac{B}{C}$$

where

A = NH₃-N read from curve, mg

B = total distillate collected including the H₃BO₃, ml

C = distillate taken for nesslerization, ml

D = original sample size, ml

Calculate organic Kjeldahl nitrogen, in mg/l, as follows:

$$\text{Organic Kjeldahl Nitrogen} = \text{TKN} - (\text{NH}_3\text{-N})$$

Method 3: Colorimetric, Automated Phenate¹

This procedure is a completely automated method to determine total Kjeldahl nitrogen in the range of 0.05 to 2.0 mg TKN-N/l. The sample is digested with a sulfuric acid-potassium sulfate-mercuric sulfate solution. The digestate is then treated successively with alkaline phenol, sodium hypochlorite, and sodium nitroprusside. Sample absorbance is then measured to quantitate the total Kjeldahl nitrogen concentration.

The user is cautioned that the manifolds for this procedure are rather complex. If this method is selected, the special cautions provided in the procedure section should be closely adhered to.

Apparatus

Technicon autoanalyzer consisting of:

- a. Sampler II, equipped with continuous mixer
- b. Two proportioning pumps
- c. Manifold I
- d. Manifold II
- e. Continous digester
- f. Planatary pump
- g. 5-gal carboy fume-trap
- h. 80°C heating bath
- i. Colorimeter equipped with 50-mm tubular flow cell and 630-nm filters
- j. Recorder equipped with range expander
- k. Vacuum pump

Reagents

Distilled water: special precaution must be taken to ensure that distilled water is free of ammonia. Such water is prepared by passage of distilled water through an ion exchange column comprised of a mixture of both strongly acidic cation and strongly basic anion exchange resins. Furthermore, since organic contamination may interfere with this analysis, use of the resin Dowex XE-75 or equivalent which also tends to remove organic impurities is advised. The regeneration of the ion exchange column should

be carried out according to the instruction of the manufacturer.

NOTE: All solutions must be made using ammonia-free water.

Sulfuric acid: as it readily absorbs ammonia, special precaution must also be taken with respect to its use. Do not store bottles reserved for this determination in areas of potential ammonia contamination.

EDTA (2 percent solution): dissolve 20 g disodium ethylenediamine tetraacetate in 1 l of distilled water. Adjust pH to 10.5 - 11 with NaOH.

Sodium hydroxide (30 percent solution): dissolve 300 g NaOH in 1 l of distilled water.

NOTE: The 30 percent sodium hydroxide should be sufficient to neutralize the digestate. In rare cases it may be necessary to increase the concentration of sodium hydroxide in this solution to ensure neutralization of the digested sample in the manifold at the water-jacketed mixing coil.

Sodium nitroprusside (0.05 percent solution): dissolve 0.5 g $\text{Na}_2\text{Fe}(\text{CN})_5\text{NO} \cdot 2\text{H}_2\text{O}$ in 1 l distilled water.

Alkaline phenol reagent: pour 550 ml liquid phenol (88 to 90 percent) slowly with mixing into 1 l of 40 percent (400 g/l) NaOH. Cool and dilute to 2 l with distilled water.

Sodium hypochlorite (1 percent solution): dilute commercial Clorox, 200 ml to 1 l with distilled water. Available chlorine level should be approximately 1 percent. Due to the instability of this product, storage over an extended period should be avoided.

Digestant mixture: place 2 g red HgO in a 2-l container. Slowly add, with stirring, 300 ml of acid water (100 ml H_2SO_4 + 200 ml H_2O) and stir until cool. Add 100 ml 10 percent (10 g per 100 ml) K_2SO_4 . Dilute to 2 l with conc. sulfuric acid (approximately 500 ml at a time, allowing time for cooling). Allow 4 hr for the precipitate to settle or filter through glass fiber filter.

Stock solutions: dissolve 4.7619 g of predried (1 hr at 105°C) ammonium sulfate in distilled water and dilute to 1.0 l in a volumetric flask. 1.0 ml = 1.0 mg N.

Standard solution: dilute 10.0 ml of stock solution to 1000 ml. 1.0 ml = 0.01 mg N. Using the standard solution, prepare the following standards in 100-ml volumetric flasks:

<u>ml Standard Solution/100 ml</u>	<u>Conc., mg N/l</u>
0.0	0.00
0.5	0.05
1.0	0.10
2.0	0.20
4.0	0.40
6.0	0.60
8.0	0.80
10.0	1.00
15.0	1.50
20.0	2.00

Procedure

Set up the Technicon manifolds as shown in Figures 3-26 through 3-28.

NOTE: In the operation of manifold No. 1, the control of four key factors is required to enable manifold No. 2 to receive the mandatory representative feed. First, the digestant flowing into the pulse chamber (PC1) must be bubble free; otherwise, air will accumulate in A-7, thus altering the ratio of sample to digestant in digester. Second, in maintaining even flow from the digester helix, the peristaltic pump must be adjusted to cope with differences in density of the digestate and the wash water. Third, the sample pickup rate from the helix must be precisely adjusted to ensure that the entire sample is aspirated into the mixing chamber. Finally, the contents of the mixing chamber must be kept homogeneous by the proper adjustment of the air bubbling rate.

NOTE: In the operation of manifold No. 2, it is important in the neutralization of the digested sample to adjust the concentration of the NaOH so that the waste from the C-3 debubbler is slightly acidic to Hydrion B paper.

NOTE: The digester temperature is 390°C for the first stage and 360°C for the second and third stages.

Allow both colorimeter and recorder to warm up for 30 min. Run a baseline with all reagents, feeding distilled water through the sample line. Adjust dark current and operative opening on colorimeter to obtain stable baseline.

Set sampling rate of Sampler II at 20 samples per hour, using a sample to wash ratio of 1 to 2 (1-min sample, 2-min wash).

Arrange various standards in sampler cups in order of increasing concentration. Complete loading of sampler tray with unknown samples. Switch sample line from distilled water to sampler and begin analysis.

Calculations

Prepare standard curve by plotting peak heights of processed standards against concentration values. Compute concentration of samples by comparing sample peak heights with standard curve.

It is suggested that any sample with a calculated concentration less than 10 percent of the sample analyzed just prior to it should be rerun.

Figure 3-26. AAI manifold 1 for the determination of TKI

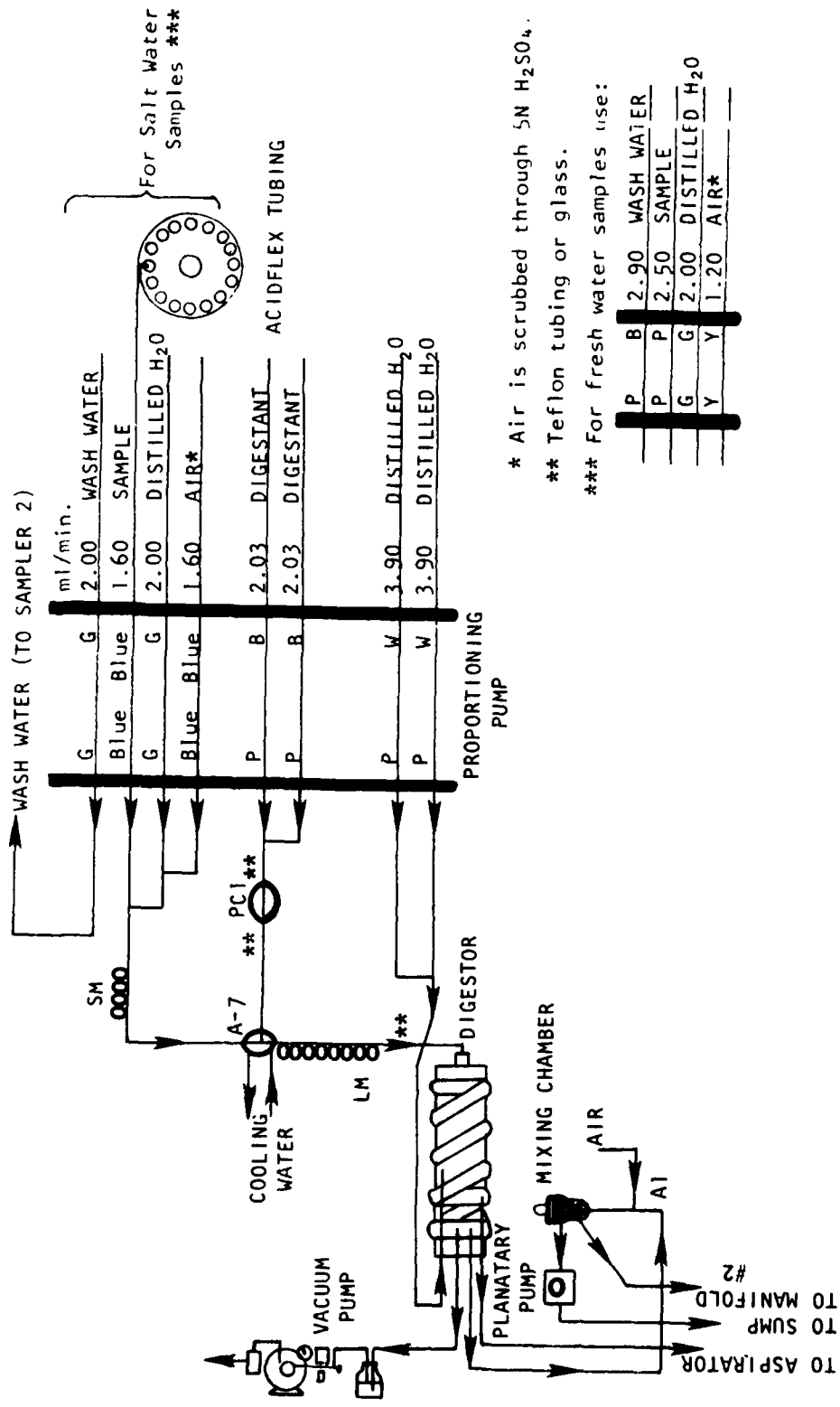

Figure 3-27. AAI manifold 2 for the determination of TKN

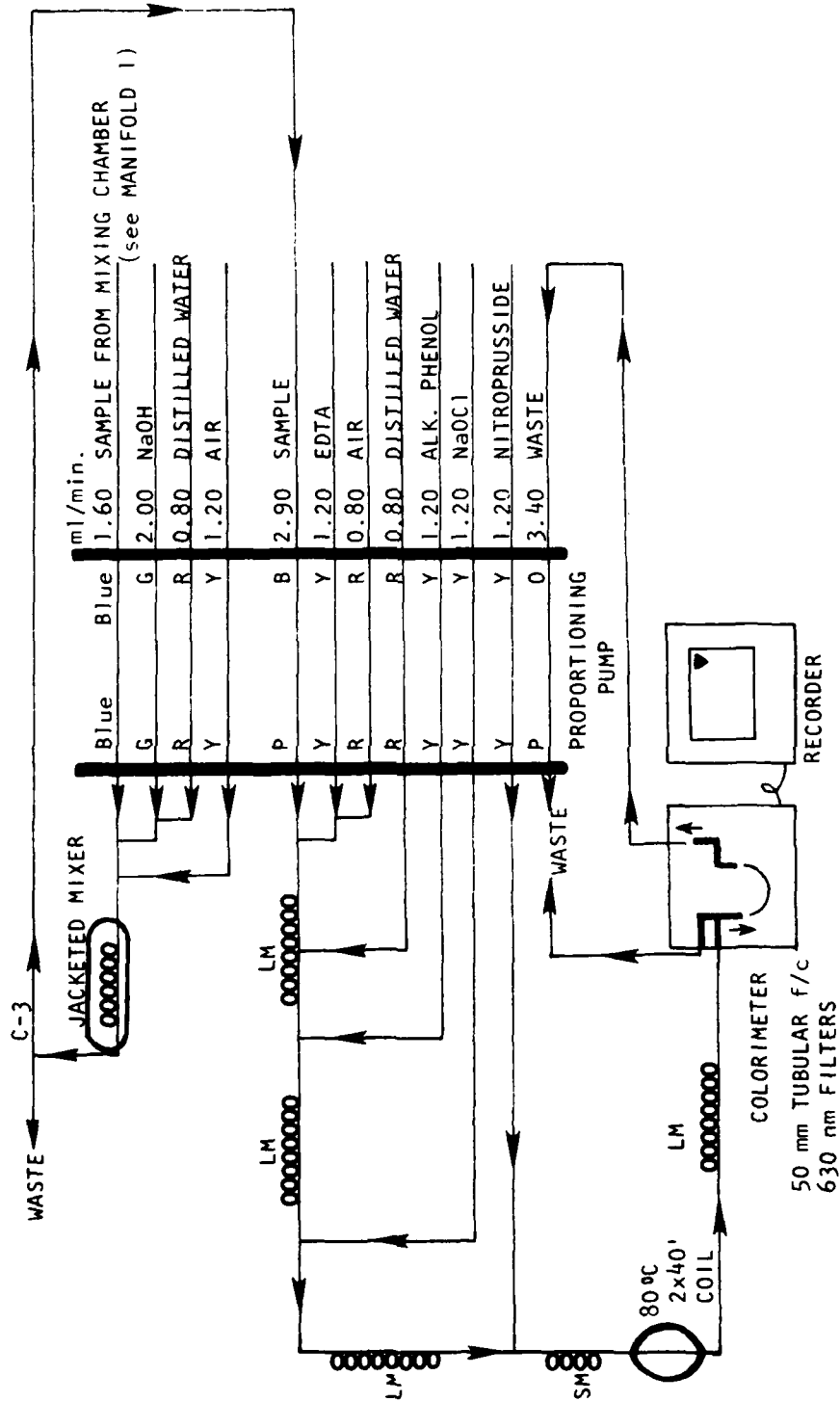
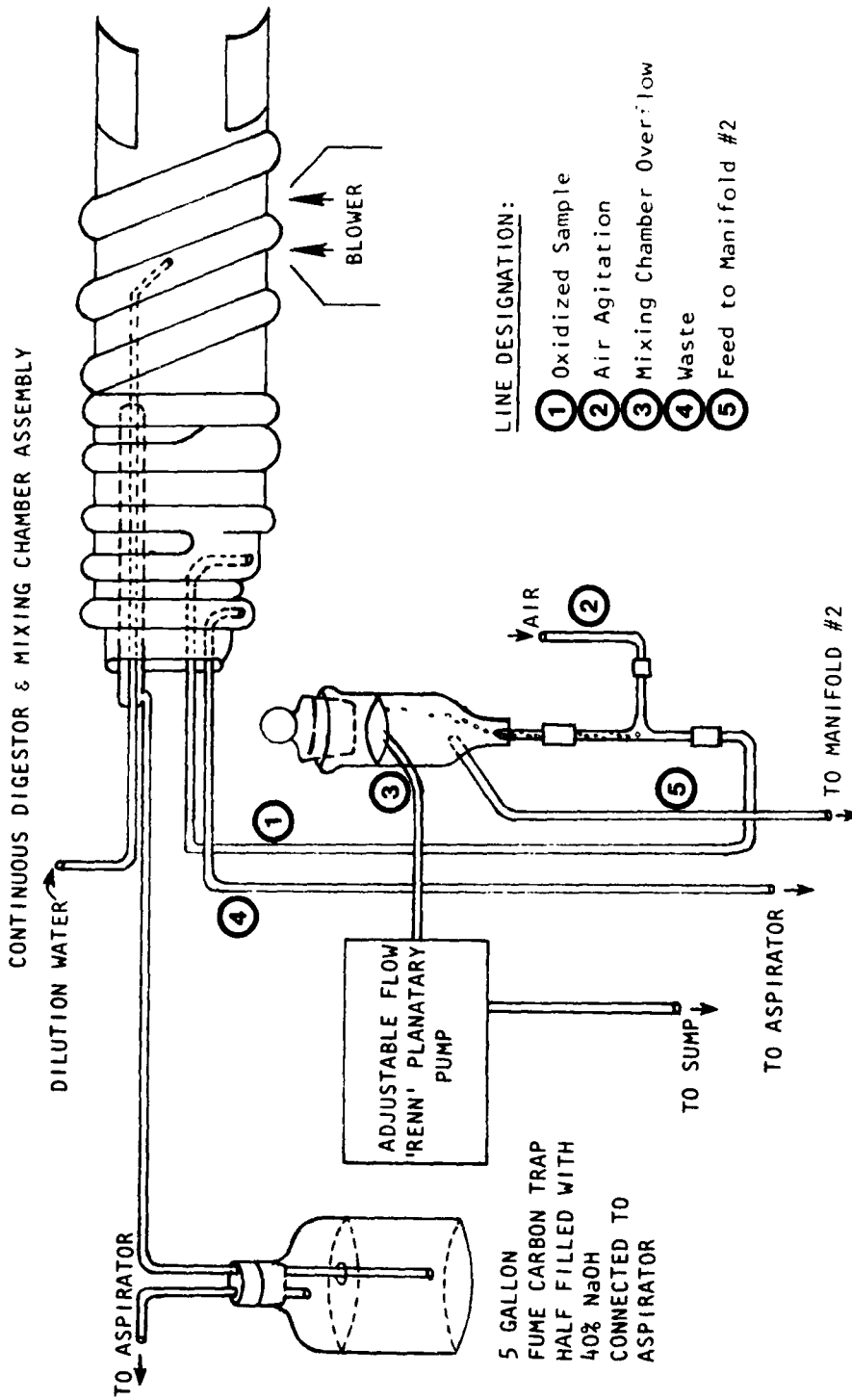

Figure 3-28. Continuous digester for the automated determination of total Kjeldahl nitrogen



Procedures for Sediment Samples

Method 1: Kjeldahl Digestion

This procedure is essentially the same as that used for TKN analysis of water samples. The sample is digested with a sulfuric acid-potassium sulfate-mercury sulfate solution to convert organic nitrogen to ammonia. The digestate is made alkaline and the ammonia is distilled into boric acid. This solution is then analyzed for ammonia.

Apparatus

Digestion apparatus

Distillation apparatus

Reagents

Digestion solution:

- a. Dissolve 8 g red mercuric oxide, HgO , in 50 ml 1:5 H_2SO_4 and dilute to 100 ml with distilled water.
- b. Prepare a second solution by dissolving 267 g K_2SO_4 in 1300 ml distilled water and 400 ml conc. sulfuric acid. Add 50 ml of the mercuric sulfate solution and dilute to 2 l.

Phenolphthalein indicator solution: either the aqueous (a) or alcoholic (b) solution may be used:

- a. Dissolve 5 g phenolphthalein disodium salt in distilled water and dilute to 1 l. If necessary, add 0.02 N NaOH dropwise until a faint pink color appears.
- b. Dissolve 5 g phenolphthalein in 500 ml 95 percent ethyl alcohol or isopropyl alcohol and add 500 ml distilled water. Add 0.02 N NaOH dropwise until a faint pink color appears.

Sodium hydroxide-sodium thiosulfate solution: dissolve 500 g NaOH and 25 g $Na_2S_2O_3 \cdot 5H_2O$ in distilled water and dilute to 1 l.

Boric acid solution: dissolve 20 g anhydrous boric acid, H_3BO_3 , in ammonia-free water and dilute to 1 l.

Procedure

Weigh out a 0.5- to 1.0-g aliquot of wet sediment. Transfer to a 800-ml digestion tube and add 100 ml digestion solution. Boil until white fumes appear. Continue heating for an additional 30 min. During this time, the sample flask should be rotated occasionally.

Cool sample to room temperature. Add 500 ml ammonia-free water and 0.3 ml phenolphthalein indicator. Carefully add 25 to 30 ml

NaOH-thiosulfate solution to the Kjeldahl flask without mixing the sample. Place the flask on a digestion rack and mix.

NOTE: If the solution is not red at this point, additional NaOH-thiosulfate solution must be added until a red color appears.

Distill over approximately 300 ml of liquid at a rate of 6 to 10 ml/min. Collect the distillate in 50 ml 2 percent boric acid. Dilute to 500 ml.

Analyze the sample using one of the automated methods, direct nesslerization, or titration procedures for ammonia as described in the water section. Nesslerization should only be used when the ammonia concentration is less than 1 mg/l and the titration procedure should only be used when the ammonia concentration is greater than 1 mg/l.

Calculations

$$\text{Total Kjeldahl Nitrogen mg/kg (wet basis)} = \frac{(x)(y)(1000)}{(g)}$$

$$\text{Total Kjeldahl Nitrogen mg/kg (dry basis)} = \frac{(x)(y)(1000)}{(g)(\% S)}$$

where

x = ammonia concentration in distillate, mg/l

y = total volume of distillate, l (0.5 as described)

g = wet weight of sediment used, g

% S = percent solids in sediment (as decimal fraction)

Method 2: Block Digestion

The sample is digested with a sulfuric acid-potassium sulfate-mercury sulfate solution on a Technicon digestion block. The digest is diluted to volume and analyzed with an autoanalyzer.

Apparatus

Technicon BD-40 block digester

Technicon #114-0009-02 test tube rack

Pyrex digestion tubes, 1 by 8 in.

Technicon autoanalyzer:

- a. Sampler with 30/hr 2:1 cam
- b. Proportionating pumps

- c. Colorimeter
- d. Recorder
- e. Digital printer (optional)
- f. Ammonia manifold as shown in Figures 3-13 and 3-14.

Teflon boiling stones

Reagents

Ammonia-free water.

Digesting solution: dissolve 2.0 g of HgO in 25 ml of 6 N H₂SO₄. Then carefully add 200 ml of conc. H₂SO₄ to 500 ml of water. While the strong acid solution is still hot, dissolve 134 g of K₂SO₄ in it. Add the HgO solution. Cool the solution, dilute to 1 l, and store above 20°C. It is extremely important that precipitation of the K₂SO₄ be avoided, as this will result in low recoveries for TKN. The digestion tube dilution water should be nitrogen and phosphorus free.

Reagents for automated dilution manifold (Figure 3-13): prepare the sampler wash solution by adding 35 ml of conc. H₂SO₄ to 500 ml of water and diluting to 1 l. Prepare the dilution manifold solution by diluting 12.5 ml of 10 N NaOH to 1 l with water.

Reagents for automated ammonia manifold (Figure 3-14): Prepare complexing reagent by dissolving 33 g of potassium sodium tartrate and 24 g of sodium citrate in 900 ml of water, diluting to 1 l, and adding 0.25 ml of Brij-35 wetting agent (Technicon No. T21-0110).

Prepare alkaline phenol solution: dissolve 83 g of phenol and 36 g of sodium hydroxide in 900 ml of water, cooling, and diluting to 1 l. Store the solution at 4°C.

Prepare sodium hypochlorite solution: dilute 200 ml of Clorox (5.25 percent available Cl₂) to 1 l with water.

Prepare sodium nitroprusside reagent: dissolve 0.5 g of sodium nitroprusside in 900 ml of water and dilute to 1 l. Store the solution at 4°C.

Standards: Prepare stock nitrogen standard containing 0.100 mg N/ml by dissolving 1.050 g of glutamic acid, dried at 105°C for 1 hr, in 900 ml of water. Add 2 ml of conc. H₂SO₄ and dilute to 1 l.

Procedure

Weigh out 0.5 to 1.0 g of dry weight equivalent sediment and transfer to a digestion tube. Add 10 ml digestion solution and 2 to 3 Teflon boiling stones. Mix samples well using a genie vortex mixer.

Place samples in holder and place holder on the digestion block. Heat the samples for 1 hr at 200°C and 1 hr at 370°C (total digestion time is 2 hr).

Cool samples to room temperature and dilute to 75 ml with distilled water. Allow solids to settle and decant sufficient liquid to fill autoanalyzer sample cups.

Place standards in sample tray in order of decreasing concentration. Continue filling tray with unknown samples. After the instrument has warmed up for 30 min and a stable baseline has been achieved, begin processing samples at the rate of 30/hr.

Calculations

Determine the ammonia concentrations in the digestates by comparing sample peak height with the standard curve based on the instrument response to the standard ammonia solutions. Calculate the total Kjeldahl nitrogen concentration in the same as follows:

$$\text{TKN mg/kg (wet weight)} = \frac{(x)(y)(1000)}{(g)}$$

$$\text{TKN mg/kg (dry weight)} = \frac{(x)(y)(1000)}{(g)(\% S)}$$

where

x = ammonia concentration in digestate, mg/l

y = volume of digestate, l (0.075 l as written)

g = wet weight of sample, g

% S = percent solids in sediment (as decimal fraction)

NITROGEN
(Organic)

A specific procedure is not provided for this parameter since it can be calculated mathematically^{1,3} or defined by sample treatment.^{1,3} Mathematically, organic nitrogen can be calculated as total Kjeldahl nitrogen minus the ammonia concentration of the sample. Analytically, the sample is pretreated by distilling off the ammonia at a pH of 9.5. The residual is subjected to one of the total Kjeldahl nitrogen methods described earlier and the result is termed organic nitrogen.

Sample Handling and Storage

Since organic nitrogen is defined as the difference between total Kjeldahl nitrogen and ammonia nitrogen, samples should be handled as discussed earlier for these parameters. This information is presented in Figure 3-12 for ammonia and Figure 3-24 for total Kjeldahl nitrogen. Any of the water fractions, W1, W2, or S1A, may be analyzed for organic nitrogen. However, it is recommended that nitrogen analyses be run on wet sediment samples only. Samples stored either dried or frozen may be altered by the oxidation of nitrites and the absorption or volatilization of ammonia. In addition, the microbial population may alter the organic nitrogen concentration. To minimize these potential effects, wet sediment samples should be used and processed as soon as possible. This suggestion applies to all forms of nitrogen in sediments as indicated in Figures 3-12, 3-16, 3-23, and 3-24.

Calculations

Organic nitrogen is the difference between total Kjeldahl nitrogen and ammonia nitrogen.

Water samples:

$$\text{Organic nitrogen-N mg/l} = \text{TKN-N mg/l} - \text{NH}_3\text{-N mg/l}$$

Sediment samples:

$$\text{Organic nitrogen-N mg/kg} = \text{TKN-N mg/kg} - \text{NH}_3\text{-N mg/kg}$$

References

1. Environmental Protection Agency. "Methods for Chemical Analysis of Water and Wastes." Environmental Monitoring and Support Laboratory, EPA; Cincinnati, Ohio (1974).
2. American Public Health Association. Standard Methods for the Examination of Water and Wastewater Including Bottom Sediments and Sludges. 14th Edition. APHA; New York, New York. 1193 p. (1976).
3. Environment Canada. "Analytical Methods Manual." Inland Waters Directorate, Water Quality Branch; Ottawa, Canada (1974).
4. American Society for Testing Materials. "Annual Book of ASTM Standards, Part 31, Water." American Society for Testing Materials; Philadelphia, Pennsylvania (1976).
5. Hesse, P. R. A Textbook of Soil Chemical Analysis. Chemical Publishing Company; New York, New York. 520 p. (1971).
6. Carter, M. J. "Wastewater Sample Preservation Data for Twenty Common Water Quality Parameters." National Environmental Enforcement Center; Denver, Colorado (1978).
7. Environmental Protection Agency. "Methods for Chemical Analysis of Water and Wastes." Environmental Monitoring and Support Laboratory, EPA; Cincinnati, Ohio (1979).
8. Technicon Industrial Systems. "Individual/Simultaneous Determination of Nitrogen and/or Phosphorus in BD Acid Digests." Industrial Method No. 320-74 W/B, Technicon Industrial Systems; Tarrytown, New York. 9 p. (1977).
9. Jirka, A. M., Carter, M. J., May, D., and Fuller, F. D. "Ultraviolet Semi-Automated Method for the Simultaneous Determination of Total Phosphorus and Total Kjeldahl Nitrogen in Wastewater." Environmental Protection Agency, Central Regional Laboratory; Chicago, Illinois. 27 p. (no date).

PHOSPHATES

(Soluble Reactive, Total, Organic)

Phosphates in the environment are known to exist in several different chemical forms such as orthophosphate, condensed phosphates, and organic phosphates. The distinction between these forms is operationally defined but the conditions have been selected so they may be used for interpretive purposes.^{1*} A common feature of each fraction is that the phosphate is converted to orthophosphate, which is then quantified using a colorimetric method.

Soluble reactive phosphorus is defined as that phosphate that will pass through a 0.45- μ pore size membrane filter and react with the colorimetric reagents without additional treatment. Organic phosphate is defined as the difference between total phosphate and acid hydrolyzable phosphate. The acid hydrolyzable phosphate fraction, in turn, is defined as the phosphate concentration that results from the acid digestion of the sample at 100°C. The total phosphate fraction is determined by a strong acid digestion of the sample at elevated temperatures.

Each of the colorimetric procedures for phosphate relies on the formation of molybdophosphoric acid. With two of the methods either ascorbic acid or stannous chloride^{1,2} is used to reduce the heteropoly acid to molybdenum blue, which is proportional to the initial phosphate concentration. The third method relies on the formation of a yellow complex when vanadium is added to molybdophosphoric acid. The intensity of the yellow complex is proportional to the initial phosphate concentration.¹ The ascorbic acid and stannous chloride procedures are subject to arsenic interference and the vanadium procedure is the least sensitive of the three procedures.

Sample Handling and Storage

A flowchart for collection of phosphate samples is presented

* References can be found on page 3-235.

in Figures 3-29 to 3-31. Sediments to be analyzed for total phosphates may be stored in a wet, dried, or frozen condition. Work with raw and treated sewage demonstrated that total phosphate was stable for 4 weeks in acid-preserved samples regardless of storage temperature.³ However, if the various phosphate forms are to be determined, the samples should be processed as soon as possible and preferably within 1 day.

Water samples should be filtered immediately when soluble reactive phosphate is to be determined. The sample may be preserved by freezing or the addition of 40 mg HgCl₂/l. (The addition of HgCl₂ may interfere with phosphate analysis if the chloride concentration of the sample is less than 50 mg/l.⁴) The addition of acid is not recommended for the preservation of soluble reactive phosphate since it may affect the orthophosphate-hydrolyzable phosphate equilibrium. Separate samples for hydrolyzable phosphate may be preserved with sulfuric acid. Glass may be the preferred sample containers at low soluble reactive phosphate concentrations to minimize the effects of phosphate adsorption.

Figure 3-29. Handling and storage of samples for orthophosphate analysis

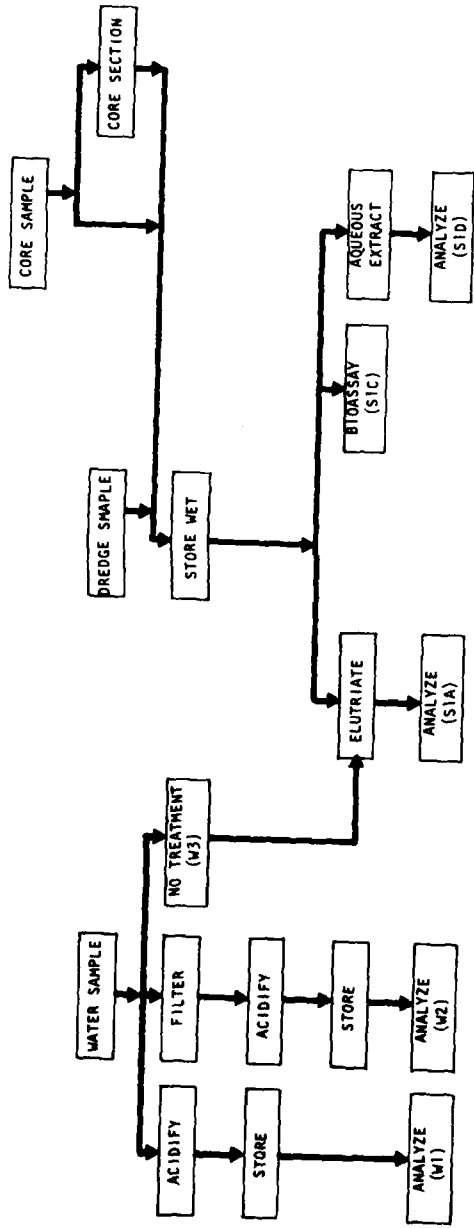

SAMPLE DESIGNATION	W1	W2	W3	S1A	S1C	S1D
PURPOSE	Total Water Conc.	Soluble Water Conc.	Used in Elutriate	Mobile Conc.	Bioavail-ability	Total Sediment Conc.
CONTAINER	G,P	G,P	G,P	G,P	G,P	G,P
SAMPLE TREATMENT	None	Filter	None	None	None	None
PRESERVATIVE	4°C	4°C	None	4°C (Minimize Air Contact.)	4°C	4°C
STORAGE TIME	24 hrs	24 hrs	<1 w	<1 w	<1 w	<1 w
DIGESTION SOLUTION	-	-	-	W3	-	Distilled Water
SAMPLE VOLUME OR WEIGHT	100 ml	100 ml	Variable	100 ml	Variable	0.5-2 g

Figure 3-30. Handling and storage of samples for organic phosphate analysis

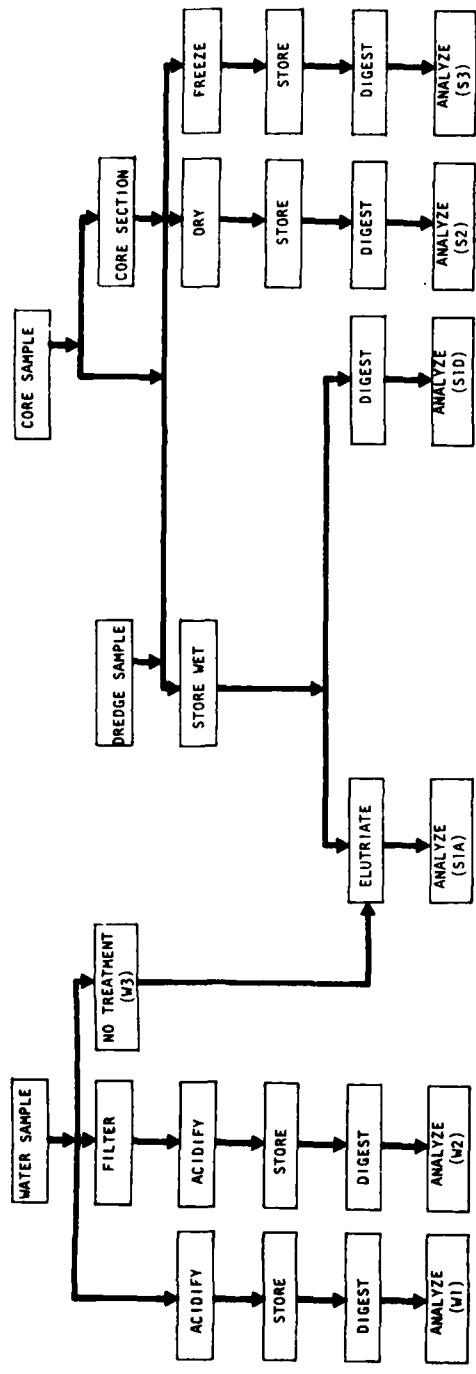

SAMPLE DESIGNATION	W1	W2	W3	S1A	S1D	S2	S3
	Total Water Conc.	Soluble Water Conc.	Used in Elutriate	Mobile Conc.	Total Sediment Conc.	Total Sediment Conc.	Total Sediment Conc.
PURPOSE	G,P	G,P	G,P	G,P	G,P	G,P	G,P
CONTAINER	None	Filter	None	None	None	Air Dry	Freeze
SAMPLE TREATMENT	H ₂ SO ₄ , pH2 4°C	H ₂ SO ₄ , pH2 4°C	None	4°C (Minimize Air Contact. Keep Field Moist.)	4°C	None	None
PRESERVATIVE	24 hr	24 hr	<1 w	<1 w	<1 w	-	-
STORAGE TIME	HOT H ₂ SO ₄	HOT H ₂ SO ₄	W3	W3	HOT H ₂ SO ₄	HOT H ₂ SO ₄	HOT H ₂ SO ₄
DIGESTION SOLUTION	100 ml	100 ml	Variable	100 ml	0.5-5 g	0.5-5 g	0.5-5 g
SAMPLE VOLUME OR WEIGHT							

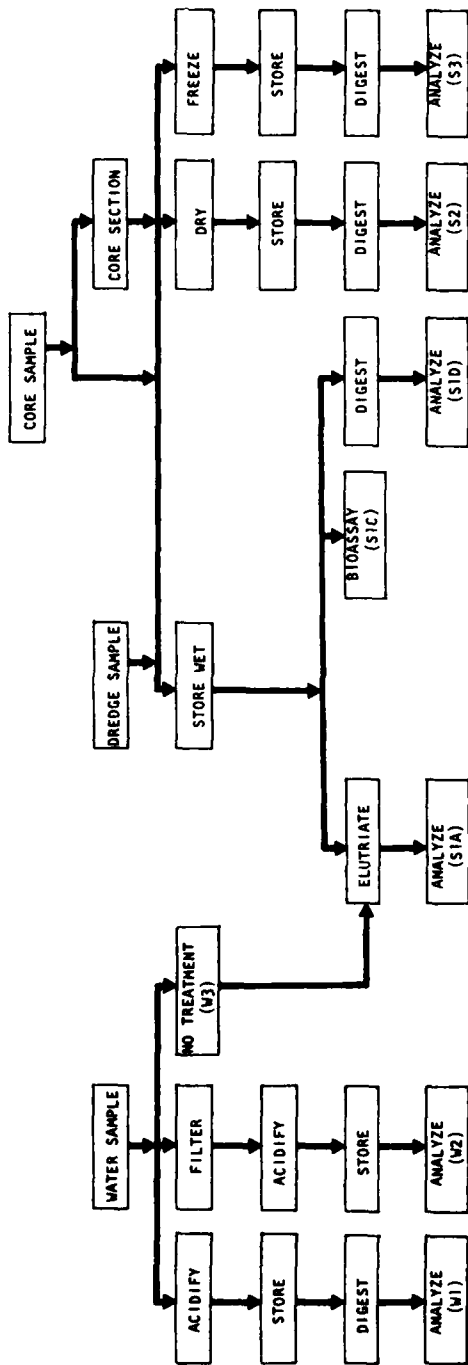

SAMPLE DESIGNATION	W1		W2		W3		S1A		S1C		S2		S3	
	Total Water Conc.	Soluble Water Conc.	Used In Elutriate	Mobile Conc.	Bioavail-ability	Total Sediment Conc.	Total Sediment Conc.							
PURPOSE	G,P	G,P	G,P	G,P	G,P	G,P	G,P	G,P	G,P	G,P	G,P	G,P	G,P	G,P
CONTAINER	None	Filter	None	None	None	None	None	None	None	None	Air Dry	Freeze	Freeze	Freeze
SAMPLE TREATMENT	H ₂ SO ₄ to pH<2 or HgCl ₂ 1 day	H ₂ SO ₄ to pH<2 or HgCl ₂ 1 day	None	4°C (Minimize Air Contact. Keep Field Moist.)	4°C	4°C	4°C	4°C	4°C	4°C	None	None	None	None
PRESERVATIVE	Strong Acid	None	-	W3	-	Strong Acid	Strong Acid	Strong Acid	Strong Acid	Strong Acid	Strong Acid	Strong Acid	Strong Acid	Strong Acid
STORAGE TIME	50-100 ml	50-100 ml	Variable	Variable	Variable	Variable	Variable	Variable	Variable	Variable	>4 w	>4 w	>4 w	>4 w
DIGESTION SOLUTION	Strong Acid	None	-	W3	-	Strong Acid	Strong Acid	Strong Acid	Strong Acid	Strong Acid	Strong Acid	Strong Acid	Strong Acid	Strong Acid
SAMPLE VOLUME OR WEIGHT	50-100 ml	50-100 ml	Variable	Variable	Variable	Variable	Variable	Variable	Variable	Variable	0.5-2 g	0.5-2 g	0.5-2 g	0.5-2 g

Figure 3-31. Handling and storage of samples for total phosphate analysis

PHOSPHATES

(Soluble Reactive)

Procedures for Water Samples (W2, S1A)

Method 1: Ascorbic Acid, Manual¹

Five colorimetric procedures are presented for the determination of phosphate. Each are based on essentially the same principle. However, the ascorbic acid and stannous chloride procedures are generally more sensitive than the vanadomolybdate procedure. The ascorbic acid methodology has probably received wider usage because of relative ease and stability of the reducing agent.

Apparatus

Colorimeter or spectrophotometer equipped for use at 885 nm. A light path of 2.5 cm or longer would be preferred

Acid-washed glassware: all glassware should be washed in hot 1:1 HCl and rinsed with distilled water. Commercial detergents should never be used

Reagents

Sulfuric acid solution, 5 N: dilute 70 ml conc. H₂SO₄ to 500 ml with distilled water.

Potassium antimonyl tartrate: dissolve 1.3715 g K(SbO)C₄H₄O₆ · 1/2 H₂O in 400 ml distilled water. Dilute to 500 ml with distilled water and store in a glass-stoppered bottle.

Ammonium molybdate solution: dissolve 20 g (NH₄)₆Mo₇O₂₄ · 4 H₂O in 500 ml distilled water. Store in a plastic bottle at 4°C.

Ascorbic acid: dissolve 1.76 g ascorbic acid in 100 ml distilled water. The solution is stable for about 1 week at 4°C.

Combined reagent: mix the above reagents in the following proportions for 100 ml combined reagent: 50 ml 5 N H₂SO₄, 5 ml potassium antimonyl tartrate, 15 ml ammonium molybdate, and 30 ml ascorbic acid. All reagents must reach room temperature before they are mixed. Add the reagents in the order given and mix the resultant solution after each addition. The combined reagent is stable for 4 hr.

Stock phosphate solution: dissolve 219.5 mg anhydrous potassium dihydrogen phosphate in distilled water and dilute to 1000 ml. 1.0 ml = 50.0 µg PO₄-P.

Procedure

Pipet 50 ml W2 or S1A sample or standard into a 125-ml Erlenmeyer flask. Add 1 drop phenolphthalein indicator. If a red color develops, add 5 N H₂SO₄ dropwise until the color disappears. Add 8.0 ml

combined reagent and mix.

After 10 min, but prior to 30 min after adding the combined reagent, measure the absorbance of each sample at 885 nm relative to the reagent blank.

If the samples are turbid or colored, a blank must be prepared by adding all reagents except ascorbic acid and potassium antimonyl tartrate to the sample. Measure the absorbance relative to the reagent blank and subtract from each sample.

Calculations

Prepare a calibration curve by plotting known phosphate concentration vs. standard absorbance. Determine the phosphate concentrations of the samples by comparing the measured sample absorbance with the standard curve.

Method 2: Ascorbic Acid, Automated⁴

Apparatus

Technicon autoanalyzer system consisting of:

- a. Sampler
- b. Manifold (AAI) or Analytical Cartridge (AII)
- c. Proportioning pump
- d. Heating bath, 50°C
- e. Colorimeter equipped with 15- or 50-mm tubular flow cell
- f. 650- to 660- or 880-nm filter
- g. Recorder
- h. Digital printer for AII (optional)

Acid-washed glassware: all glassware should be washed in hot 1:1 HCl and rinsed in distilled water. Commercial detergents should never be used

Reagents

Sulfuric acid solution: dilute 70 ml conc. H_2SO_4 to 500 ml with distilled water.

Potassium antimonyl tartrate: dissolve 0.3 g $K(SbO)C_4H_4O_6 \cdot 1/2 H_2O$ in distilled water and dilute to 100 ml. Store at 4°C in a dark, glass-stoppered bottle.

Ammonium molybdate: dissolve 4 g $(NH_4)_6Mo_7O_{24} \cdot 4 H_2O$ in 100 ml distilled water. Store in a plastic bottle at 4°C.

Ascorbic acid: dissolve 1.8 g ascorbic acid in 100 ml distilled water. The solution is stable for about 1 week when stored at 4°C.

Combined reagent: mix the following reagents in the following proportions and order to prepare 100 ml of reagent: 50 ml sulfuric acid, 5 ml potassium antimonyl tartrate, 15 ml ammonium molybdate, and 30 ml ascorbic acid. All reagents must reach room temperature before they are mixed. If turbidity forms in the combined reagent, shake and let it stand for a few minutes until the turbidity disappears. This solution is stable for approximately 4 hr and must be prepared fresh for each run.

Stock phosphate solution: dissolve 0.4393 g predried (105°C for 1 hr) KH_2PO_4 in distilled water and dilute to 1000 ml. 1.0 ml = 0.1 mg P.

Procedure

To 50 ml of W2 or S1A sample, add 1 drop phenolphthalein indicator. If a red color develops, add sulfuric acid solution dropwise to discharge the color. Acid samples must be neutralized with 1 N NaOH.

Set up the autoanalyzer manifold as shown in Figure 3-32 or 3-33. Allow the colorimeter and recorder 30 min to warm up. Obtain a stable baseline by using all reagents and feeding distilled water through the sample line.

Place standards in sample tray in order of decreasing concentration. Complete tray with unknown samples. Switch sample line from distilled water to sampler and begin analyses.

Calculations

Prepare a standard curve by plotting peak height vs. standard concentration. Compute sample concentrations by comparing peak sample height with the standard curve.

Method 3: Stannous Chloride, Manual¹

Apparatus

Colorimeter or spectrophotometer equipped for use at 690 nm

Acid-washed glassware: all glassware used in the procedure should be washed in hot 1:1 HCl and rinsed thoroughly with distilled water. Commercial detergents should not be used

Reagents

Sulfuric acid solution: dilute 300 ml conc. H_2SO_4 to approximately 600 ml with distilled water. When solution has cooled, add 4 ml conc. HNO_3 and dilute to 1 l.

Figure 3-32. AAI manifold for the ascorbic acid determination of phosphorus

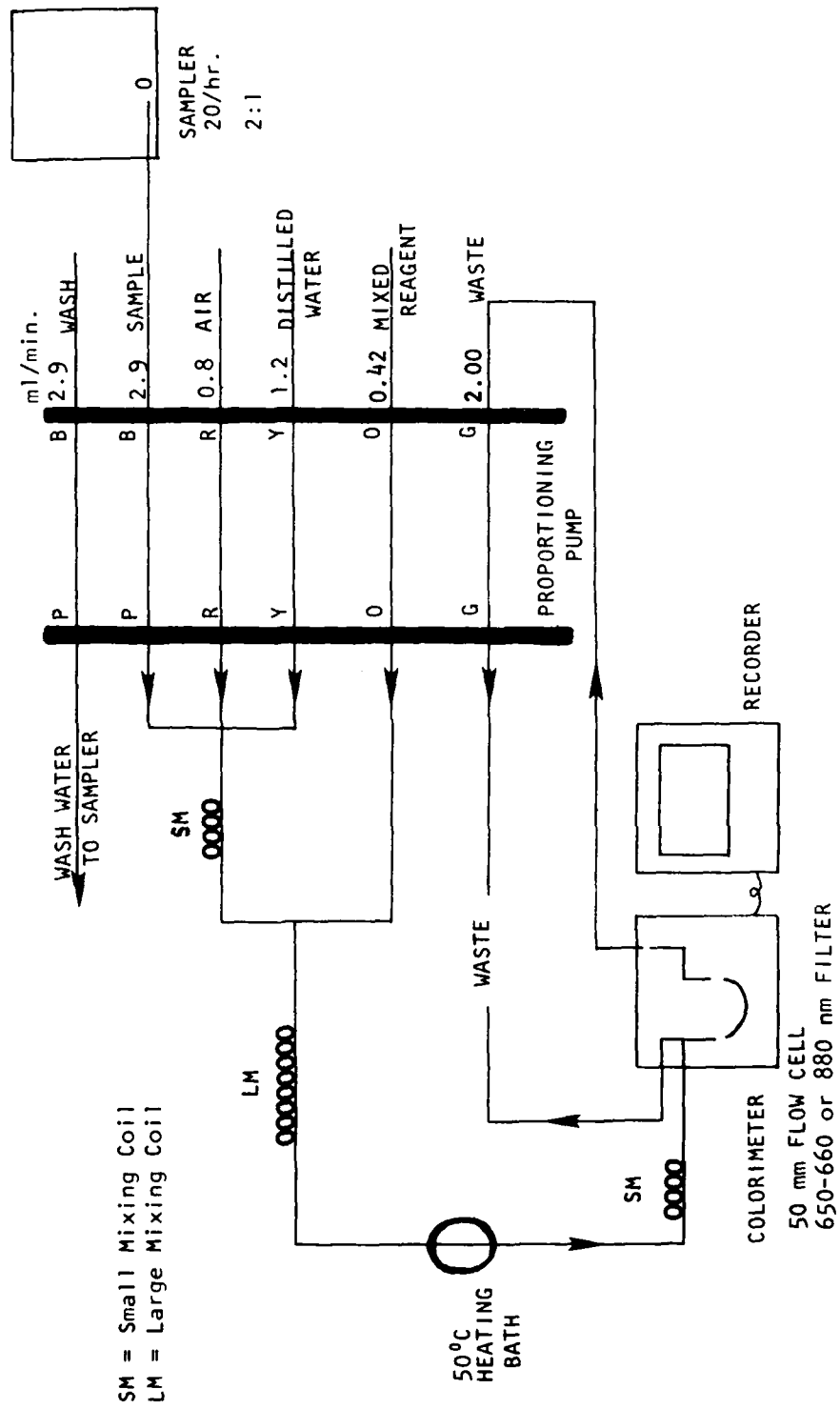
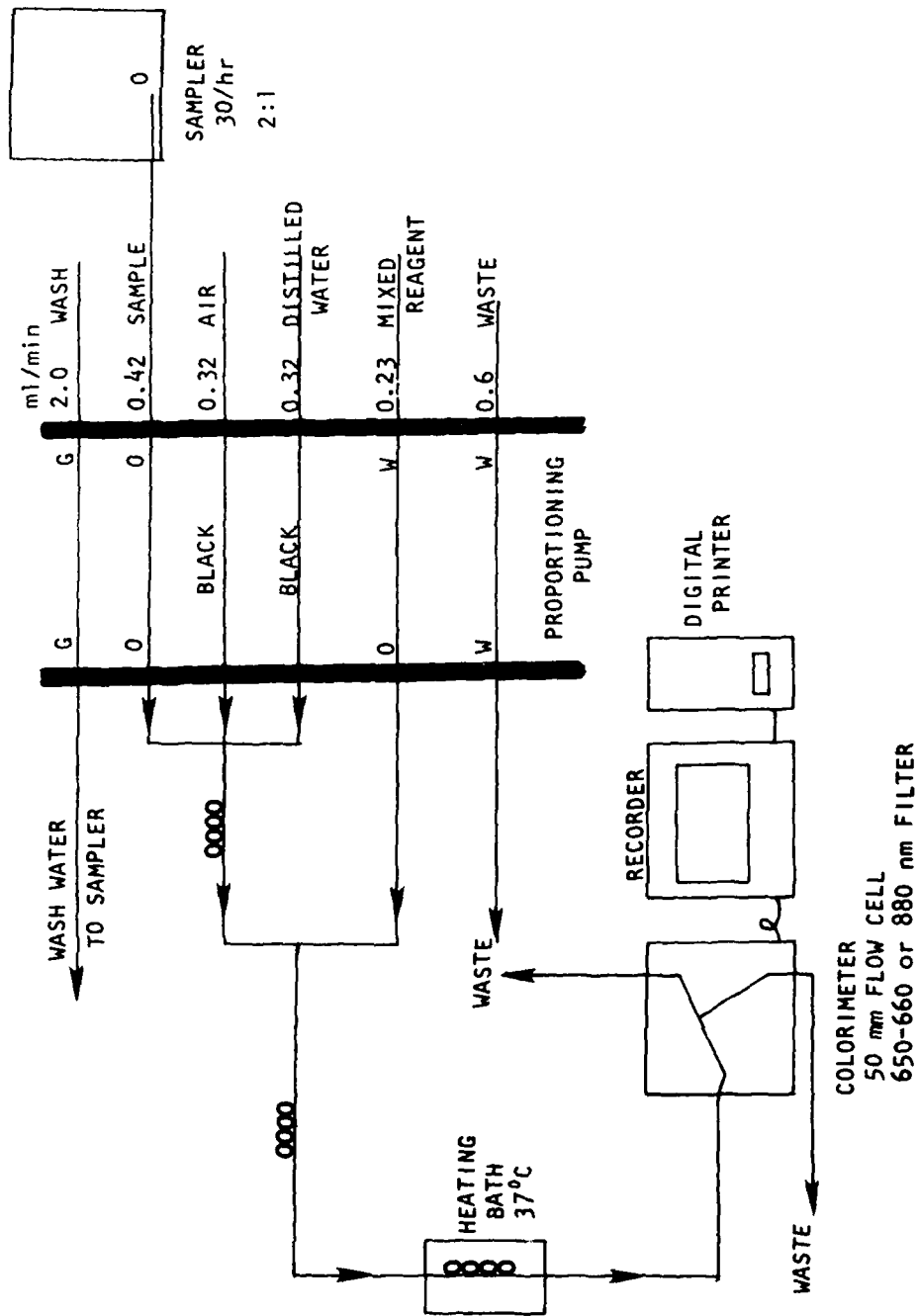

Figure 3-33. AAI cartridge for the ascorbic acid determination of phosphorus



Ammonium molybdate reagent I: dissolve 25 g $(\text{NH}_4)_6\text{Mo}_7\text{O}_{24} \cdot 4 \text{H}_2\text{O}$ in 175 ml distilled water. Cautiously add 280 ml conc. H_2SO_4 to 400 ml distilled water. Cool, add the molybdate solution, and dilute to 1 l with distilled water.

Stannous chloride reagent I: dissolve 2.5 g fresh $\text{SnCl}_2 \cdot 2 \text{H}_2\text{O}$ in 100 ml glycerol. Heat in a water bath and stir with a glass rod to hasten dissolution.

Standard phosphate solution: dissolve 219.5 mg anhydrous potassium dihydrogen phosphate, KH_2PO_4 , and dilute to 1000 ml with distilled water. 1.0 ml = 50 μg $\text{PO}_4\text{-P/l}$.

Procedure

To 100 ml of W2 or S1A sample or standard containing not more than 0.2 mg P and free from color and turbidity, add 1 drop phenolphthalein indicator. If the sample turns pink, add sulfuric acid dropwise until the color disappears. If more than 0.25 ml is required, continue titrating until the color disappears but dilute an aliquot of the pH adjusted sample to 100 ml with distilled water for analysis.

The rate of color development and the color intensity of the final solution are dependent upon temperature. Therefore, samples and standards should be equilibrated at the same temperature and be within 2°C of each other at the time of color development.

Add 4.0 ml molybdate reagent I to the pH-adjusted sample and mix thoroughly. Add 0.5 ml (10 drops) stannous chloride and mix thoroughly. Ten minutes after the addition of the colorimetric reagents, but prior to 12 min after the addition of the reagents, determine the absorbance of the standard or sample relative to a distilled water blank at 690 nm.

NOTE: Because of the dependence of color intensity on time, a serious effort must be made to adhere to a strict time schedule and allow a constant color development time for all standards and samples.

Calculations

Prepare a standard curve by plotting observed standard absorbance vs. phosphate concentration. Compare observed sample absorbance with the standard curve to determine sample phosphate concentration.

Method 4: Stannous Chloride, Automated²

Apparatus

Technicon autoanalyzer system (Figure 3-34 or 3-35) consisting of:

- a. Sampler
- b. Heating bath, 30°C
- c. Manifold (AAI) or Analytical Cartridge (AAII)
- d. Proportioning pump
- e. Colorimeter, 50-mm flow cells, 660-nm filters
- f. Recorder
- g. Range expander

Reagents

Ammonium molybdate solution: dissolve 25 g ammonium molybdate, $(\text{NH}_4)_6\text{Mo}_7\text{O}_{24} \cdot 4 \text{H}_2\text{O}$, in 175 ml distilled water. Dilute 155 ml conc. H_2SO_4 to 400 ml with distilled water. Mix the two solutions and dilute to 1 l.

Stock stannous chloride: dissolve 5 g stannous chloride, $\text{SnCl}_2 \cdot 2 \text{H}_2\text{O}$, in 25 ml conc. HCl and dilute to 500 ml with distilled water. This solution is stable for approximately 2 weeks at 5°C.

Stannous chloride working solution: mix 30 ml stock stannous chloride solution with 25 ml conc. HCl and dilute to 500 ml with distilled water. This solution is stable for approximately 12 hr.

Sulfuric acid solution: add 300 ml conc. H_2SO_4 to distilled water and dilute to 1 l.

Standard phosphate solution: dissolve 219.5 mg anhydrous potassium dihydrogen phosphate, KH_2PO_4 , and dilute to 1000 ml with distilled water. 1.0 ml = 50 $\mu\text{g PO}_4\text{-P}$.

Prepare appropriate working phosphate solutions by diluting the standard phosphate solution. Working solutions should be made daily.

Procedure

Set up the autoanalyzer manifold as shown in Figure 3-34 or Figure 3-35. Figure 3-34 is for samples in the phosphate range of 0 to 50 $\mu\text{g/l}$ and Figure 3-35 is for samples in the phosphate range of 50 to 500 $\mu\text{g/l}$.

Allow the colorimeter and recorder 30 min to warm up. Obtain a stable baseline by using all reagents and feeding distilled water through the sample line.

Place standards in the sample tray in order of decreasing concentration. Fill the remainder of the tray with W2 or S1A samples.

Figure 3-34. Stannous chloride manifold for the determination of phosphorus, low level (0-50 $\mu\text{g}/\ell$)

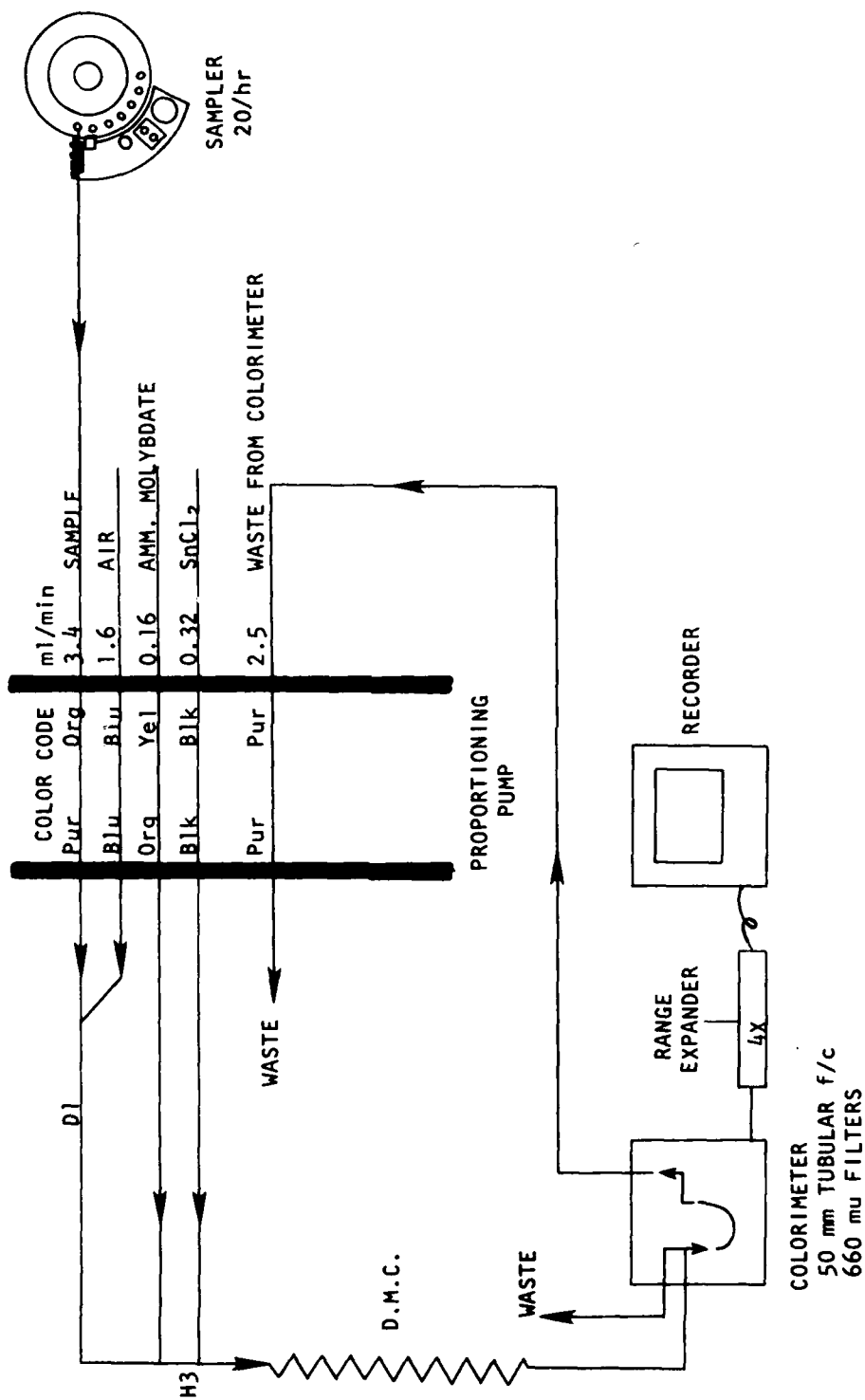
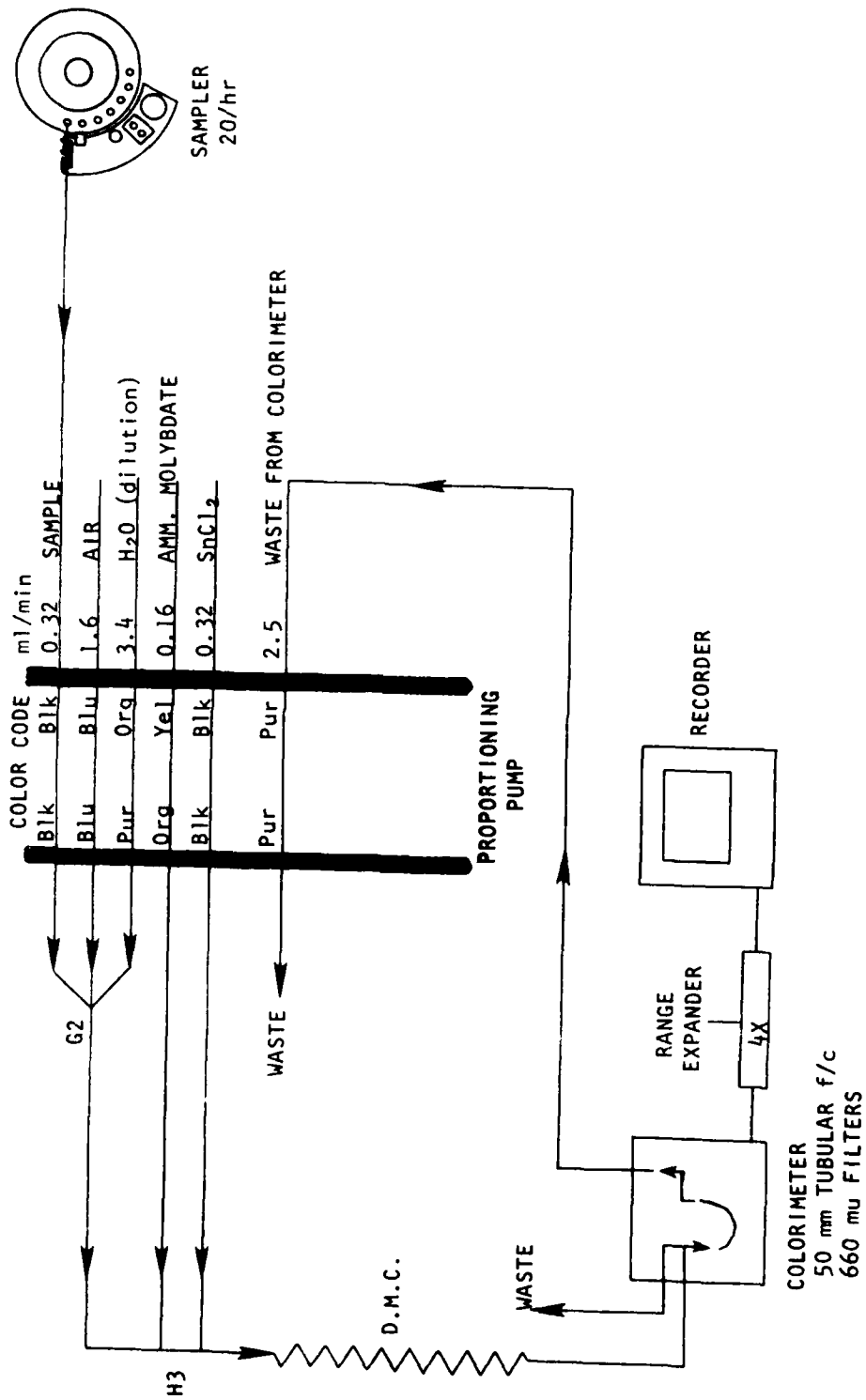

Figure 3-35. Stannous chloride manifold for the determination of phosphorus, high level (50-500 $\mu\text{g}/\text{l}$)



Switch sample line from distilled water to sampler and begin analysis. Wash water should be acidified with sulfuric acid at the rate of 10 ml 30 percent H_2SO_4 /ℓ distilled water.

Every time a new batch of stannous chloride reagent is used, a new set of phosphate standards must be run. Standard solutions should be run periodically to check the validity of the calibration curve.

Calculations

Prepare a standard curve by plotting peak height vs. standard concentration. Compute sample concentrations by comparing sample peak height with the standard curve.

Method 5: Vanadomolybdophosphoric Acid, Manual¹

Apparatus

Spectrophotometer equipped with a 470- to 490-nm filter

Glassware: all glassware should be washed in hot 1:1 HCl and rinsed thoroughly with distilled water. Commercial detergents should not be used

Reagents

Activated carbon.

Vanadate-molybdate reagent:

Solution A: dissolve 25 g ammonium molybdate, $(\text{NH}_4)_6\text{Mo}_7\text{O}_{24} \cdot 4 \text{H}_2\text{O}$, in 400 ml distilled water.

Solution B: dissolve 1.25 g ammonium metavanadate, NH_4VO_3 , in 300 ml boiling distilled water. Cool and add 330 ml conc. HCl.

Cool Solution B to room temperature, add Solution A, and dilute to 1 ℓ with distilled water.

Standard phosphate solution: dissolve 219.5 mg anhydrous potassium dihydrogen phosphate, KH_2PO_4 , in distilled water and dilute to 1 ℓ
1.0 ml = 50 μg $\text{PO}_4\text{-P}$.

Procedure

Remove any excessive color from the sample by shaking 50 ml sample with 200 mg activated carbon for 5 min. Remove the carbon by filtering the sample through a Whatman No. 42 filter paper or the equivalent.

NOTE: Check each batch of activated carbon for phosphate release.

Transfer 35 ml of phosphate standard or sample, containing 1000 μg P or less, to a 50-ml volumetric flask. Add 10 ml vanadate-molybdate reagent and dilute to volume with distilled water. Prepare a reagent blank using 35 ml distilled water and 10 ml vanadate-molybdate reagent.

Allow 10 min for color development and measure the absorbance of the sample vs. the reagent blank. The wavelength to be used depends on the sensitivity desired. A wavelength of 470 nm is usually used but wavelengths between 400 and 490 nm can be used.

Calculations

Prepare a calibration curve by plotting standard absorbance vs. phosphate concentration. Determine the phosphate concentration of the samples by comparing sample absorbance with the standard curve.

Procedure for Sediment Samples (SID)

This procedure is operationally defined. Total soluble phosphate is defined as the amount of phosphate leached from sediment in a stated time period. It is recommended that moist sediments be used for this determination. The reason for this restriction is that drying or freezing of sediment samples may cause irreversible conversion or sorption of the phosphate in the sediment sample (Figure 3-29). The final leachate is then analyzed for soluble phosphate using one of the procedures provided in the section on water analysis.

Sample preparation⁵

Place 10 g of blended, wet sediment (SID) into a 100-ml beaker. Add 50 ml distilled water and mix. Allow the suspension to settle overnight.

Centrifuge, if necessary, then filter through a 0.45- μ pore-size membrane filter. Do not wash the filter. Transfer the filtrate to a 250-ml beaker. Add 1 ml strong acid solution (300 ml conc. H_2SO_4 and 4 ml conc. HNO_3 diluted to 1 l) and 0.4 g potassium persulfate ($K_2S_2O_8$). Boil solution for 90 min, adding distilled water, if necessary, to keep the volume between 25 and 50 ml.

Cool the sample, add 1 drop phenolphthalein, and titrate with 1 N NaOH to a faint pink color. Transfer to a 100-ml volumetric flask and dilute to volume with distilled water.

Quantification procedure

Analyze the digested leachate by one of the five methods presented in the section for soluble reactive phosphate analysis in water samples.

Calculations

Compare the absorbance of the sediment leachate with a standard phosphate curve to determine the phosphate concentration. The soluble phosphate concentration of the sediment sample is calculated as

follows:

$$\text{Soluble Phosphate mg/kg (wet basis)} = \frac{(x)(0.1 \text{ l})(1000)}{(g)}$$

$$\text{Soluble Phosphate mg/kg (dry basis)} = \frac{(x)(0.1 \text{ l})(1000)}{(g)(\% S)}$$

where

x = phosphate concentration in leachate, mg PO₄-P/l

0.1 = volume of leachate, l (0.1 l as written)

g = wet weight of sample used, g

% S = percent solids in sediment sample as a decimal fraction

PHOSPHATE
(Total)

Procedures for Water Samples (W1, W2, S1A)

There are three digestion methods available to determine total phosphate. In terms of increasing severity, these are: (a) persulfate digestion, (b) sulfuric acid-nitric acid digestion, and (c) perchloric acid digestion. A less severe digestion method should only be used when it has been shown to be equivalent to the most severe method for the type of samples being analyzed.

Each of the procedures subjects the water samples to a strong acid digestion at elevated temperatures. The digests are then filtered to remove remaining particulate matter and diluted to a convenient volume. Analyze the digests for phosphate using one of the procedures in the soluble reactive phosphate section and report the results as total phosphate.

Sample preparation

Select a digestion procedure from those indicated below and proceed as indicated.

- a. Persulfate digestion.^{1,2} Transfer a 50-ml aliquot of W1, W2, or S1A sample or standard to a 125-ml Erlenmeyer flask. Add 1 drop of phenolphthalein indicator solution. If a red color develops, add 10.8 N H₂SO₄ dropwise until the color disappears. Add 1.0 ml of the sulfuric acid solution (300 ml conc. H₂SO₄ diluted to 1 ℓ) and 0.4 g solid ammonium persulfate.

Either (1) boil the acidified sample on a preheated hot plate for 40 min or until the volume is reduced to 10 ml, or (2) autoclave the sample for 30 min at 1.0 to 1.4 kg/cm² (15 to 20 psig). Cool the samples, neutralize to the phenolphthalein endpoint with 1 N NaOH, and dilute to 100 ml with distilled water.

- b. Sulfuric acid-nitric acid digestion.¹ Transfer a 50-ml aliquot of W1, W2, or S1A sample or standard to a micro Kjeldahl flask. Add 1 ml conc. H₂SO₄ and 5 ml conc. HNO₃. Digest on a micro-Kjeldahl digestion rack to a volume of 1 ml and continue heating until HNO₃ is removed and solution is colorless.

Cool and add 20 ml distilled water. Add 1 drop phenolphthalein and neutralize with 1 N NaOH to a faint pink color. Filter, if necessary, and transfer the digest to a 100-ml volumetric flask. Wash the digestion flask and filter into the volumetric flask. Dilute to 100 ml with distilled water.

- c. Perchloric acid digestion.¹ Transfer a 50-ml aliquot of W1, W2, or S1A sample or standard to a 125-ml Erlenmeyer flask. Acidify to the methyl orange endpoint with conc. HNO₃. Add an excess of 5 ml conc. HNO₃. Evaporate the sample to 15 to 20 ml on a steam bath or hot plate. Cover the sample with a watch glass when necessary to avoid sample loss due to splattering. Add 10 ml conc. HNO₃, 10 ml 70 to 72 percent HClO₄, and a few boiling chips. Heat gently on a hot plate until the evolution of dense white HClO₄ fumes. If the solution is not clear, add 10 ml conc. HNO₃ and continue heating.
- Cool the solution and neutralize with 6 N NaOH to the phenolphthalein endpoint. Filter the solution, if necessary, and dilute to 100 ml with distilled water.

Quantification procedure

The digestion procedure should produce a homogeneous, liquid phase digest. These samples should be analyzed for phosphate using one of the procedures for soluble reactive phosphate in water samples.

Calculations

Determine the phosphate concentration of the digests by comparing measured sample absorbances with a standard phosphate curve. Calculate the phosphate concentration of the initial sample by multiplying the phosphate concentration of the digest by the ratio of digest volume to initial sample volume:

$$\text{Total phosphate mg/l} = \frac{(x)(d)}{s}$$

where

- x = phosphate concentration in digest, mg/l
d = volume of digest, ml (100 ml as written)
s = sample volume, ml (50 ml as written)

Report the results for W2 and S1A samples as total soluble phosphate. Report the results for W1 samples as total phosphate.

Procedures for Sediment Samples (S1D, S2, S3)

There are numerous methods available for the digestion of sediment samples to be analyzed for phosphate. In fact, Aspila et al.⁶ reported a literature review summarizing 77 methods. Most procedures consist of strong acid digestion or treatment with an oxidizing agent and a strong acid.

A common feature of the digestion procedures is that the sample treatments are designed to convert all the phosphate compounds to ortho phosphate. The orthophosphate is then quantified using one of the analytical procedures presented earlier. Therefore, a choice of digestion techniques is presented but the analytical procedures are not repeated.

Sample Handling and Storage

Phosphate may interconvert between several forms. However, the compounds are not considered volatile. Therefore, if it is decided to run total phosphate, samples may be stored in a field moist, dried, or frozen condition. This information is summarized in Figure 3-31.

Sample pretreatment

Weigh out a 0.5- to 1.0-g dry weight equivalent of the sediment sample. Continue with one of the digestion procedures presented in a through e below:

- a. Perchloric acid digestion.^{*1,7} Weigh into a 125-ml beaker an 0.5-g dry weight equivalent of sediment sample. Add 25 ml distilled water and 5 ml conc. HNO₃.

Mix the sample and evaporate on a hot plate to 5 to 10 ml. Transfer the sample to a 125-ml conical flask. Rinse the beaker with 5 ml conc. HNO₃. Add 5 ml conc. HNO₃, 10 ml of 70 to 72 percent HClO₄, and a few boiling stones. Heat on a hot plate and evaporate to

* Stone or asbestos cement hoods recommended when perchloric acid is to be used.

the evolution of dense white HClO_4 fumes. If the solution is not clear at this point, cover the flask with a watch glass and continue heating until it clears. Add additional conc. HNO_3 , if necessary.

Cool the solution and neutralize to the phenolphthalein endpoint with 6 N NaOH .

Filter the sample, if necessary; transfer to a volumetric flask, and dilute to volume. Standards should be carried through the digestion procedure to correct for an ionic strength effect on the colorimetric procedure.

- b. Sulfuric acid-nitric acid digestion.⁵ Weigh out 0.5 to 1.0 g sediment sample. Transfer to a 250-ml Erlenmeyer flask using a minimum amount of water. Add 5 ml conc. H_2SO_4 and 25 ml conc. HNO_3 . Mix the suspension well after the addition of each acid.

Digest slowly on a hot plate with medium heat. Avoid use of high heat as this may cause superheating and result in sample loss. Continue heating until the evolution of white fumes. If the sample is not clear, add conc. HNO_3 and continue the digestion process until a clear digestate is obtained.

NOTE: Do not heat sample to dryness.

Add 25 to 50 ml distilled water to the hot sample and filter immediately. Pour the filtrate through a 4- by 3/4-in. column of cation exchange resin to remove iron. Wash the column with approximately 25 ml distilled water.

Titrate the sample with 6 N NaOH to the phenolphthalein endpoint. Back titrate the sample dropwise with 1 N H_2SO_4 until colorless. Transfer the solution to a 100-ml volumetric flask and dilute to volume.

- c. Persulfate digestion (sealed bomb).⁶ Accurately weigh a 0.3- to 0.5-g dry weight equivalent of the sample and transfer to a Parr PFTE bomb (Parr Instrument Co., Moline, Illinois). Add 3.0 ± 0.1 g potassium persulfate and 5.0 ml conc. H_2SO_4 . Seal the bomb and heat at 135°C for 2 hr.

Transfer the contents of the bomb to a 500-ml volumetric flask and dilute with distilled water.

- d. Persulfate digestion.⁶ Weigh 0.5-g dry weight equivalent of the sample and transfer to a 150-ml beaker. Add 10 ml 30 percent H_2SO_4 and 2 g potassium persulfate. Mix the suspension and heat on a hot plate for 1 hr. Filter, if necessary, into a 100-ml volumetric flask and dilute to volume.

- e. Block digestion.^{8,9} Weigh 0.5 g dry weight equivalent of sediment and transfer to a Technicon glass digestion tube (No. 114-0024-02). Add 10 ml digestion solution, 1 ml HgO solution, and 2 to 3 boiling stones (ChemPlast, Inc., Wayne, New Jersey). Mix samples using a vortex mixer.

NOTE: The digestion solution is prepared by gradually adding 600-g K₂SO₄ to 1-l conc. H₂SO₄. Allow solution to cool to room temperature, stopper, and store above 20°C.

NOTE: The mercury solution is prepared by dissolving 5-g HgO in 100 ml 10 percent H₂SO₄.

Place samples in digestion rack (Technicon No. 114-0009-02) and place the rack on a block digester (Technicon No. BD-40). Heat samples 1 hr at 200°C, followed by 1 hr at 370°C. Cool samples and dilute to 75 ml.

Quantification procedure

Dilute the sediment digests to a convenient volume. Analyze the digests for phosphate using one of the procedures described earlier.

Calculations

Determine the phosphate concentrations of the digests by comparing sample absorbance with the standard phosphate curve. Calculate the phosphate concentration of the initial sediment samples as follows:

$$\text{Total phosphate mg/kg (wet weight)} = \frac{(x)(y)(1000)}{(g)}$$

$$\text{Total phosphate mg/kg (dry weight)} = \frac{(x)(y)(1000)}{(g) (\% S)}$$

where

x = phosphate concentration in sediment digest, mg/l

y = final volume of sediment digest, l

g = wet weight of sample digest, g

% S = percent solids in sediment sample as a decimal fraction

PHOSPHATES

(Organic)

The determination of organic phosphate requires the analyses of two samples. One sample is subjected to a total phosphate digestion and a second sample is subjected to an acid hydrolysis. The digests are analyzed for phosphate using one of the colorimetric procedures and organic phosphate is calculated by subtracting the acid hydrolysis results from the total phosphate results.

Sample Handling and Storage

Samples for organic phosphate analysis may be stored in either glass or plastic containers and preserved with the addition of sulfuric acid. However, since the maximum recommended holding time for hydrolyzable phosphate and total phosphate is presently 24 hr,⁴ the holding time for organic phosphate samples should also be 24 hr (Figure 3-30).

Procedures for Water Samples (W1, W2, S1A)⁴

Sample Preparation

Two subsamples must be prepared for phosphate analysis in order to determine organic phosphate. One sample is digested in strong acid at elevated temperatures. A second sample is hydrolyzed under less severe conditions.

- a. Total digest. Transfer a 50-ml sample to an Erlenmeyer flask or a micro Kjeldahl flask and proceed with either the persulfate digestion, sulfuric acid-nitric acid digestion, or perchloric acid digestion, as described for the total phosphate analysis of water samples.
- b. To a second 100-ml sample, or a sample aliquot diluted to 100 ml, add 1 drop phenolphthalein indicator solution. If a red color develops, add a strong acid solution dropwise until the color disappears. Add a 1 ml excess of strong acid.

Boil the solution for 90 min. Add distilled water as

required to keep the water level between 25 and 50 ml. Cool the sample, neutralize with sodium hydroxide to a faint pink color, and dilute to 100 ml with distilled water. As an alternative, the sample may be autoclaved for 30 min at 1.0 to 1.4 kg/cm² (15 to 20 psig).

Prepare a series of orthophosphate standards and process through the hydrolysis procedure. This is necessary to compensate for the ionic strength effects due to the hydrolysis procedure. Cool, neutralize, and dilute the standards as indicated with the samples.

Quantification procedure

Analyze the digests from both procedure a and procedure b for orthophosphate using one of the procedures provided in the section for soluble reactive phosphate in water samples. Label the digests from procedure a as total phosphate and the digests from procedure b as hydrolyzable phosphate.

Calculations

Prepare a standard phosphate curve by plotting absorbance vs. phosphate concentration. Determine the phosphate concentration of the sample digests by comparing the sample absorbance with the standard curve. Correct the digest phosphate concentration for any dilution during the sample pretreatment:

$$\text{Sample Phosphate} = \frac{(x)(d)}{s}$$

where

x = the phosphate concentration of the digest, µg/l

d = final volume of sample digest, ml

s = initial sample volume, ml

The organic phosphate concentration is then calculated as:

$$\text{Organic Phosphate} = \text{Total Phosphate} - \text{Hydrolyzable Phosphate}$$

When a total water sample (W1) is used, the result is total organic phosphate. When a filtered water sample (W2, S1A) is used, the result is soluble organic phosphate or filterable organic phosphate.

Procedures for Sediment Samples (S1D, S2, S3)

Two procedures are presented for pretreatment of sediment samples to determine organic phosphate. Because of the difference in techniques, organic phosphate should be considered an operationally defined parameter.

Method 1: Acid Hydrolysis¹

Sample pretreatment

It is necessary to prepare two subsamples for phosphate analysis to calculate organic phosphate.

- a. Total digest. Weigh out a 0.3- to 1.0-g dry weight equivalent of the sediment sample and proceed as described in the section on total phosphate analysis of sediments.
- b. Place 5 to 10 g sediment in a 150-ml beaker. Add 50 ml distilled water and 5 ml strong acid solution (300 ml conc. H_2SO_4 and 4 ml conc. HNO_3 diluted to 1 l). Mix the suspension and boil on a hot plate for 90 min. Add distilled water as necessary to maintain a liquid level of 25 to 50 ml.

Cool the sample and filter. Add 1 drop of phenolphthalein indicator and neutralize to a faint pink color with 1 N NaOH. Dilute the sample to 100 ml with distilled water.

Prepare a series of orthophosphate standards and process through the hydrolysis procedure. This is necessary to compensate for the ionic strength effects due to the hydrolysis procedure. Cool, neutralize, and dilute the standards as indicated with the samples.

Quantification procedure

Analyze the sediment digests and standards carried through the digestion procedures for orthophosphate using one of the methods provided for the analysis of soluble reactive phosphate in water.

Calculations

Prepare the appropriate standard curves by plotting standard absorbance vs. phosphate concentration. Determine the phosphate

concentration of the sediment digests by comparing sample absorbance with the standard curve. Calculate the total and hydrolyzable phosphate concentrations of the sediment sample as:

$$\text{Phosphate Concentration } \mu\text{g/kg (wet weight)} = \frac{(x)(v)(1000)}{(g)}$$

$$\text{Phosphate Concentration mg/kg (dry weight)} = \frac{(x)(v)(1000)}{(g)(\% S)}$$

where

x = phosphate concentration of the sediment digest, mg/l

v = volume of sample digest, l

g = wet weight of sediment sample, g

% S = percent solids of sediment (written as a decimal fraction)

The results from pretreatment a are total phosphate concentrations and the results from pretreatment b are hydrolyzable phosphate. Sediment organic phosphate concentrations are calculated as total phosphate minus hydrolyzable phosphate.

Method 2: Acid Extraction⁶

Sample retreatment

It is necessary to prepare two subsamples for phosphate analysis to calculate organic phosphate.

- a. Total digest. Weigh out a 0.3- to 1.0-g dry weight equivalent of the sediment sample and proceed with one of the five digestion procedures described in the section on total phosphate analysis of sediments.
- b. Acid extract. Weigh a second 0.3- to 0.5-g dry weight sample and transfer to a 100-ml volumetric flask. Extract the sample with 50 ml 1 N HCl for 16 hr in a room temperature water bath. Neutralize the sample to the phenolphthalein endpoint with 6 N NaOH.

Quantification procedure

Dilute the total digest from a and the acid extract from b to convenient volumes. Analyze for orthophosphate using one of the methods provided for the analysis of soluble reactive phosphate in water.

Calculations

Prepare the appropriate standard curve by plotting standard absorbance vs. phosphate concentration. Determine the phosphate

concentration of the sediment digests by comparing sample absorbance with the standard curve. Calculate the total and acid extractable phosphate concentrations of the sediment sample as:

$$\text{Phosphate concentration mg/kg (wet weight)} = \frac{(x)(v)(1000)}{(g)}$$

$$\text{Phosphate concentration mg/kg (dry weight)} = \frac{(x)(v)(1000)}{(g)(\% S)}$$

where

x = phosphate concentration of the sediment digest, mg/l

v = volume of sediment digest, l

g = wet weight of sediment sample, g

% S = percent solids of sediment (expressed as a decimal fraction)

The results from pretreatment a are total phosphate concentrations and the results from pretreatment b are acid extractable phosphate. Sediment organic phosphate concentrations are calculated as total phosphate minus acid extractable phosphate.

References

1. American Public Health Association. Standard Methods for the Examination of Water and Wastewater. 14th Edition. APHA; New York, New York. 1193 p. (1976).
2. Environment Canada. "Analytical Methods Manual." Inland Water Directorate, Water Quality Branch; Ottawa, Ontario Canada (1974).
3. Carter, Mark J. "Wastewater Sample Preservation Data for Twenty Common Water Quality Parameters." Chemistry Branch, National Enforcement Investigation Center, U. S. EPA; Denver, Colorado (1978).
4. Environmental Protection Agency. "Manual of Methods for Chemical Analysis of Water and Wastes." Methods Development and Quality Assurance Research Laboratory, National Environmental Research Center; Cincinnati, Ohio. 298 p. (1974).
5. Great Lakes Region Committee on Analytical Methods. "Chemical Laboratory Manual for Bottom Sediments." U. S. Department of the Interior, Great Lakes Region; Chicago, Illinois. 96 p. (1968).
6. Aspila, K. I., Aremian, H., and Chan, A. S. Y. "A Semi-Automated Method for the Determination of Inorganic, Organic and Total Phosphate in Sediments." *Analyst* 101:187-197 (1976).
7. Andersen, J. M. "An Ignition Method for Determination of Total Phosphorus in Lake Sediments." *Water Res.* 10:329-331 (1976).
8. Jirka, A. M., Carter, M. J., May, D., and Fuller, F. D. "Ultramicro Semiautomated Method for Simultaneous Determination of Total Phosphorus and Total Kjeldahl Nitrogen in Wastewater." *Env. Sci. and Tech.* 10:1038-1044 (1976).
9. Anon. "Individual/Simultaneous Determination of Nitrogen and/or Phosphorus in BD and Digests." Technicon Industrial Systems Industrial Method No. 329-74 W/B. Technicon Industrial Systems; Tarrytown, New York. 9 p. (1977).

SULFIDES

Sulfides are the salts of a weak acid, H_2S . Therefore, depending on the pH, sulfides may exist as H_2S , HS^- , or S^{2-} . Sulfides are of concern because they may be potentially toxic (toxicity will vary with pH) and they may create unaesthetic conditions (odor of rotten eggs).

Sampling Procedure and Storage

The collection of samples for sulfide analysis presents two problems. The first is that H_2S is a gas. Consequently, sulfide may be lost by volatilization and/or gas stripping. The second problem is that sulfides are reducing agents and can be oxidized by dissolved oxygen. When these factors were considered, the following approach was developed for handling of sulfide samples (Figure 3-36). Water samples should be collected with a minimum of turbulence as a precaution against volatilization and oxidation of sulfides. Also, a zinc acetate preservative should be used to precipitate zinc sulfide. This is accomplished by adding 4 drops 2 N zinc acetate in a 100-ml bottle, completely filling with sample, and tightly sealing the bottle. If it is desired to determine soluble sulfides, the sample should be flocculated with alum to remove particulate matter. Filtration is likely to expose the sample to the atmosphere and cause sulfide oxidation. Sulfide analyses should be completed as soon as possible and preferably within 24 hr.

Only wet sediment samples should be analyzed for sulfides because of the likelihood of sample oxidation during the drying or the freezing/thawing cycle. Samples may be treated with zinc acetate but the efficiency of this step is unknown. The storage time for sediment samples is not known. Therefore, samples should be processed as soon as possible.

Figure 3-36. Handling and storage of samples for sulfide analysis

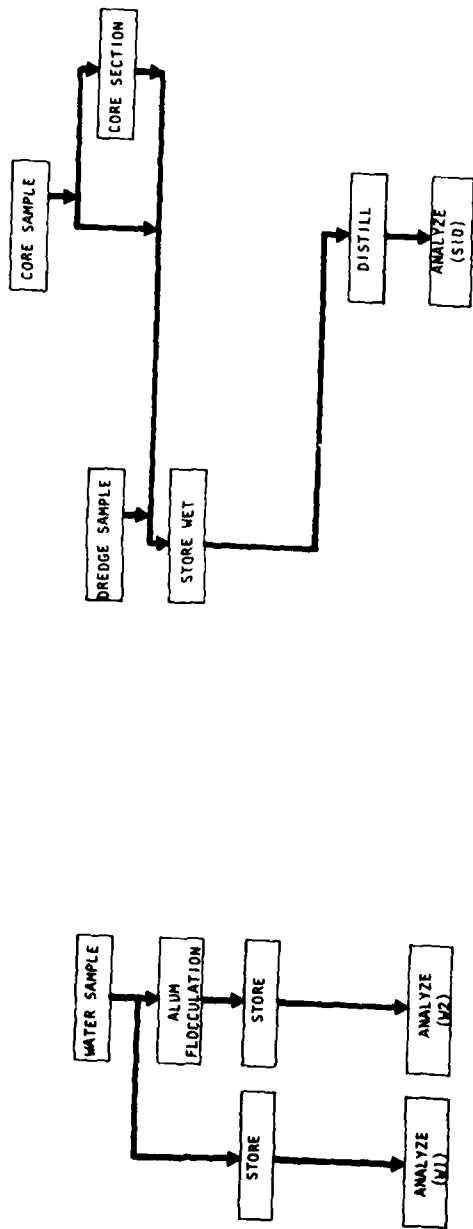

SAMPLE DESIGNATION	W1		W2		S10	
	PURPOSE	Total Water Conc.	Soluble Water Conc.	Total Sediment Conc.	PURPOSE	Total Sediment Conc.
CONTAINER	G,P	G,P	G,P	G,P	None	G,P
SAMPLE TREATMENT	None	Filter	None	None	None	None
PRESERVATIVE	Zinc Acetate	Zinc Acetate	Zinc Acetate	Zinc Acetate	(Zinc Acetate)	(Zinc Acetate)
STORAGE TIME	24 hr	24 hr	24 hr	24 hr	As soon as possible.	As soon as possible.
DIGESTION SOLUTION	Amine-Sulfuric Acid	Amine-Sulfuric Acid	Amine-Sulfuric Acid	Amine-Sulfuric Acid	HC1	HC1
SAMPLE VOLUME OR WEIGHT	25 ml	25 ml	25 ml	25 ml		

Procedures for Water Samples (W1, W2)^{1*}

Method 1: Methylene Blue, Colorimetric¹

Apparatus

Matched test tubes, approximately 125 mm long and 15 mm O.D.

Droppers, delivering 20 drops/ml methylene blue solution. To obtain uniform drops it is essential to hold the dropper in a vertical position and to allow the drops to form slowly

Spectrophotometer or filter photometer for use at a wavelength of 625 nm

Reagents

Amine-sulfuric acid stock solution: dissolve 27 g, N, N-dimethyl-p-phenylenediamine oxalate (also called p-aminodimethylaniline oxalate) in a cold mixture of 50 ml conc. H₂SO₄ and 20 ml distilled water. Cool and dilute to 100 ml with distilled water. The amine oxalate should be fresh; an old supply may be oxidized and discolored to a degree that results in interfering colors in the test. Store in a dark glass bottle. When this stock is diluted and used in the procedure with a sulfide-free sample, it must yield a colorless solution.

Amine-sulfuric acid reagent: dilute 25 ml amine-sulfuric acid stock solution with 975 ml 1 + 1 H₂SO₄. Store in a dark glass bottle.

Ferric chloride solution: dissolve 100 g FeCl₃ · 6H₂O in 40 ml water.

Sulfuric acid solution, H₂SO₄, 1 + 1.

Diammonium hydrogen phosphate solution: dissolve 400 g (NH₄)₂HPO₄ in 800 ml distilled water.

Methylene blue solution 1: use USP grade dye or one certified by the Biological Stain Commission. The dye content should be reported on the label and should be 84 percent or more. Dissolve 0.1 g in distilled water and make up to 1 l. This solution will be approximately the correct strength, but because of variation between different lots of dye, standardize against sulfide solutions of known strength and adjust its concentration so that 0.05 ml (1 drop) = 1.0 mg/l sulfide.

Standardization: put several grams of clean, washed crystals of sodium sulfide, Na₂S · 9H₂O, into a small beaker. Add somewhat less than enough water to cover crystals. Stir occasionally for a few minutes, then pour the solution into another vessel. This solution reacts slowly with oxygen, but the change is unimportant in a period of a few hours. Make the solution daily. To 1 l distilled water add 1 drop of solution and mix. Immediately

* References may be found on page 3-247.

determine the sulfide concentration by the methylene blue procedure and by the titrimetric procedure. Repeat the procedures, using more than 1 drop of Na_2S solution or smaller volumes of water, until at least five tests have been made, with a range of sulfide concentrations between 1 and 8 mg/l. Calculate the average percent error of the methylene blue result as compared to the titrimetric result. If the average error is negative, that is, the methylene blue results are lower than the titrimetric results, dilute the methylene blue solution by the same percentage, so that a greater volume will be used in matching colors. If the methylene blue results are high, increase the strength of the solution by adding more dye.

Methylene blue solution II: Dilute 10.00 ml of the adjusted methylene blue solution I to 100 ml.

Sodium hydroxide solution, NaOH , 6 N.

Aluminum chloride solution, 6 N: because of the hygroscopic and caking tendencies of this chemical, purchase 100-g (or 1/4-lb) bottles of the hexahydrate, $\text{AlCl}_3 \cdot 6\text{H}_2\text{O}$. Dissolve the contents of a previously unopened 100-g bottle in 144 ml distilled water (or the contents of a 1/4-lb bottle in 164 ml distilled water).

Sample preparation

Filtration is the routine method to distinguish between soluble and particulate phases for most chemicals in water. However, this method is not desirable for sulfide because of its labile nature. It is possible that sulfides could be oxidized or volatilized during the filtration process. Therefore, the following flocculation procedure is presented to isolate soluble sulfide in the sample:

Add 0.2 ml (4 drops) 6 N NaOH to a 100-ml glass bottle. Fill the bottle with sample and add 0.2 ml (4 drops) 6 N AlCl_3 . Carefully stopper the bottle to exclude air bubbles. Vigorously shake the bottle to mix the sample. Allow the floc to settle and draw off the clean supernatant. Analyze the sample immediately for dissolved sulfide or preserve with zinc acetate. This sample is designated W2.

NOTE: The time allowed for the floc to settle should be kept to a minimum.

Procedure

Decant as much water as possible from the preserved sample without disturbing the precipitate. Refill the bottle with distilled water (this step tends to remove interferences that may be present in the original site water) and resuspend the precipitate.

Transfer a 7.5-ml sample from the well-mixed suspension to each of two matched test tubes, using a special widetip pipet or filling to the marks on the test tubes. To one tube, add 0.5 ml amino-sulfuric acid reagent and 0.15 ml (3 drops) FeCl_3 solution. Mix immediately by slowly inverting the tube a single time. To the second tube, add 0.5 ml 50 percent H_2SO_4 and 0.15 ml (3 drops) FeCl_3 solution. Mix the second tube. Allow 3 to 5 min for color development, then add 1.6 ml $(\text{NH}_4)_2\text{HPO}_4$ solution to each test tube. The presence of sulfide will be indicated by a blue color in the first tube. Allow 3 to 15 min for the color to stabilize (at least 10 min if a zinc acetate preservative was used) and determine the absorbance of the sample. Zero the colorimeter with a portion of the sample from the second test tube (sample + sulfuric acid + FeCl_3). Determine the absorbance of the sample at 625 nm.

The reaction between sulfide and the amine-sulfuric acid reagent produces methylene blue, which is measured colorimetrically. In order to quantify the amount of sulfide in the samples, prepare appropriate dilutions of the standard methylene blue reagents that have been standardized against sodium sulfide. Record the absorbance of these standards relative to a reagent blank.

Calculations

Prepare calibration curves by plotting the measured absorbance of the standard methylene blue solutions vs. the sulfide equivalent of each solution. A straight-line relationship should be obtained between 0.0 and 1.0 mg/l. Compare sample absorbances to the standard curve to determine the sulfide concentrations.

Report the results of W1 sample analysis as total sulfide and the results of W2 sample analyses as soluble sulfide.

Method 2: Iodine Titrimetric¹

Reagents

Hydrochloric acid, HCl, 6 N.

Standard iodine solution, 0.0205 N: dissolve 20 to 25 g potassium iodide, KI, in a little water and add 3.2 g iodine. After the iodine has dissolved, dilute to 1000 ml and standardize against 0.0205 N sodium thiosulfate, using starch solution as indicator.

Standard sodium thiosulfate solution, 0.0205 N.

Starch solution.

Sodium hydroxide solution, NaOH, 6 N.

Aluminum chloride solution, 6 N: because of the hygroscopic and caking tendencies of this chemical, purchase 100-g (or 1/4-lb) bottles of the hexahydrate, $\text{AlCl}_3 \cdot 6\text{H}_2\text{O}$. Dissolve the contents of a previously unopened 100-g bottle in 144 ml distilled water (or the contents of a 1/4-lb bottle in 164 ml distilled water).

Sample preparation

The separation of soluble and particulate sulfide is accomplished by alum flocculation. Add 0.2 ml (4 drops) 6 N NaOH to a 100-ml glass bottle. Fill the bottle with sample and add 0.2 ml (4 drops) 6 N AlCl_3 . Carefully stopper the bottle to exclude air bubbles. Vigorously shake the bottle to mix the sample. Allow the floc to settle and draw off the clean supernatant. Analyze the sample immediately for dissolved sulfide or preserve with zinc acetate. This sample is designated W2.

Procedure

If the sulfide was precipitated with zinc and the water decanted, conduct the titration in the original sample bottle. If an unpreserved water sample is to be analyzed for sulfide, a separate flask will be required.

Measure from a buret a known volume of iodine solution that is stoichiometrically in excess of the amount of sulfide present. Add this solution to the original sample bottle or a 500-ml flask, whichever is applicable. Add distilled water, if necessary, to bring the volume to approximately 20 ml. Add 2 ml 6 N HCl. If the titration is to be performed in the sample bottle, the sample is now ready. If the titration is to be performed in a 500-ml flask, pipet 200 ml of unpreserved sample into the flask, taking care to discharge the sample below the surface of the acidified solution.

If the iodine color disappears, add more iodine so the color persists. Back titrate with sodium thiosulfate solution. When the solution is a pale yellow, add a few drops of starch solution and continue the titration until the blue color disappears.

Calculations

The stoichiometry of the reaction between iodine and sulfide is such that 1 ml 0.025 N iodine solution will quantitatively react with 0.4 mg of sulfide. Therefore:

$$\text{mg S/l} = \frac{400(a - b)}{c}$$

where

- a = ml 0.025 N iodine solution added
- b = ml 0.025 N thiosulfate solution used
- c = initial volume of water sample, ml

Procedure for Sediment Samples (SID)

Method 1: Distillation, Methylene Blue, Colorimetric²

Apparatus

Distillation apparatus, all glass. For large samples, a suitable assembly consists of a 1-ℓ pyrex distilling flask with Graham condenser as used for the analysis of phenols. A section of glass tubing should be connected to the tip of the condenser so that it reaches the bottom of the collection tube

Distillate collection tubes, short-form Nessler tubes, graduated at 50 and 100 ml

Spectrophotometer, for use at 650 mμ and providing a light path of 1 in. or greater

Reagents

Nitrogen, water-pumped.

Zinc acetate, 2 N: dissolve 220 g of $Zn(C_2H_3O_2)_2 \cdot 2H_2O$ in distilled water and dilute to 1 ℓ.

Zinc acetate, 0.2 N: add several drops of acetic acid to 100 ml of 2 N zinc acetate solution and dilute to 1 ℓ.

Sulfuric acid solution, 1:1: add, cautiously, 500 ml of conc. H_2SO_4 to 500 ml of distilled water in a 1-ℓ flask. Mix continuously and cool under running water while combining reagents. Cool solution before using.

Dilute sulfuric acid solution, approximately 0.1 N: dilute 5 ml of 1:1 H_2SO_4 to 1 ℓ with distilled water.

Stock amine solution: dissolve 2.7 g of N, N-dimethyl-p-phenylenediamine sulfate and dilute to 100 ml with 1:1 H_2SO_4 solution. This solution is stable for approximately 1 week.

Working amine solution: dilute 2 ml of stock amine solution to 100 ml with 1:1 H_2SO_4 solution. Prepare fresh daily.

Ferric chloride solution: dissolve 100 g of $FeCl_3 \cdot 6H_2O$ in hot distilled water and dilute to 100 ml. Cool before use.

Standard potassium biniodate solution, 0.025 N: accurately weigh out 0.8124 g $KH(IO_3)_2$ and dissolve in distilled water. Dilute to 1 ℓ.

Standard sodium thiosulfate titrant, 0.025 N: dissolve 6.205 g $Na_2S_2O_3 \cdot 5H_2O$ in distilled water and dilute to 1 ℓ. Preserve with 5 ml chloroform. Standardize against standard potassium biniodate using starch as an indicator.

Potassium iodide solution: dissolve 5 g of KI in distilled water and dilute to 100 ml.

Treated hydrochloric acid: place one or two strips of aluminum in a small beaker of conc. HCl. After violent reaction, the acid is poured off and is ready to use.

Oxygen-free dilution water: pass nitrogen gas through a sufficient quantity of distilled water for dilution requirements. A minimum of 10 min is required to displace oxygen in the water.

Sodium sulfide, reagent, crystal.

Procedure

Prepare 0.01 N sulfide solution as follows: weigh out approximately 1.2 g of large crystal $\text{Na}_2\text{S} \cdot 9 \text{H}_2\text{O}$. Wash the crystals several times with distilled water. Discard the washings and add the washed crystals to 975 ml of nitrogen-saturated distilled water. Dilute to 1 l. The exact concentration of this stock solution is determined by reacting the sulfide with an excess of iodine to give free sulfur and titrating the unreacted iodine with sodium thiosulfate.

Pipet 20 ml of stock sulfide solution into 100 ml of oxygen-free water. Add 5 ml of KI solution, 20 ml of 0.025 N $\text{KH}(\text{IO}_3)_2$ solution, and 10 ml of 0.1 N H_2SO_4 . Titrate with 0.025 N $\text{Na}_2\text{S}_2\text{O}_3$ solution using starch as an endpoint indicator. Carry a blank through the procedure and calculate the amount of reacted iodine from the difference between the blank and standard titrations. Since 1 ml of 0.025 N $\text{KH}(\text{IO}_3)_2$ is equivalent to 0.400 mg of sulfide ion, calculate the sulfide concentration in the stock solution. Calculate the volume of stock solution that contains 0.2 mg sulfide and add this amount to 900 ml of oxygen-free water. Dilute to 1 l. This is the working standard containing 2 μg S/ml.

NOTE: Sulfide solutions are extremely unstable and must be prepared fresh and used immediately. Stability is increased by using nitrogen-saturated water for dilution.

Prepare a standard curve by dilution of the working sulfide solution. Pipet 20 ml 0.2 N $\text{Zn}(\text{C}_2\text{H}_3\text{O}_2)_2$ into a series of 50-ml Nessler tubes. Add the required amounts of sulfide solution to each Nessler tube, taking care to pipet the solution below the $\text{Zn}(\text{C}_2\text{H}_3\text{O}_2)_2$ level. Dilute to 50 ml with oxygen-free water.

Equilibrate the temperature of the standards to 23° to 25°C using a water bath while the colorimetric reagents are added. Add 2 ml

dilute amine-sulfuric acid solution to the standard, mix, and add 0.25 ml (5 drops) FeCl_3 solution. Mix the solution and allow 10 min for color development. Measure the absorbance at 650 nm.

To process samples, set up the distillation apparatus. The transfer tube from the condenser should reach to the bottom of the distilled collection tube. The condenser should be attached in such a manner that it can be easily moved up or down when diluting the distillate or adding reagents.

Pipet 20 ml of 0.2 N $\text{Zn}(\text{C}_2\text{H}_3\text{O}_2)_2$ into a 100-ml Nessler tube and lower the condenser so that the transfer tubing reaches below the level of the liquid. Attach a distilling flask and pass nitrogen gas through the system for at least 10 min.

Add an aliquot of field moist sediment sample (SID) to the distillation flask. The sample should not contain more than 50 μg of sulfide. Bubble nitrogen gas through the sample to remove any oxygen dissolved in the sample. A small amount of sulfide may be driven over by the gas, so be sure that the only exit is through the zinc acetate solution in the collecting tube.

Discontinue nitrogen evolution and add rapidly several boiling stones, 2 drops of methyl orange indicator, and enough treated HCl to change the color from orange to red. Stopper as quickly as possible and heat slowly. The slower the heating rate, the greater the contact time between the evolved H_2S and $\text{Zn}(\text{C}_2\text{H}_3\text{O}_2)_2$ and the less chance of sulfide loss. Distill the solution until approximately 20 ml of distillate has been collected (roughly 5 to 8 min after the solution commences to boil). Turn off heat and remove the stopper in the distillation flask to keep the distillate from being sucked back up the condenser. Raise the transfer tube above the 50-ml mark on the collection container and dilute the solution to 50 ml.

Place the distillates in a water bath at 23° to 25°C. Add 2 ml dilute amine solution and mix. Add 0.25 ml (5 drops) FeCl_3 solution and mix. Allow 10 min for color development and measure sample absorbance at 650 nm.

Calculations

Prepare a standard curve by plotting absorbance of the standards vs. sulfide concentration. Determine the sulfide concentration of the sample distillate by comparing sample absorbance with the standard curve. Calculate the sulfide concentration of the sediment sample as follows:

$$\text{mg S/kg (wet weight)} = \frac{(C)(0.05)(1000)}{(g)}$$

$$\text{mg S/kg (dry weight)} = \frac{(C)(0.05)(1000)}{(g)(\% S)}$$

where

C = sulfide concentration in distillate, mg/l

0.05 = sample volume of distillate, l (as written)

g = wet weight of sediment aliquot, g

% S = percent solids of sediment as a decimal fraction

References

1. American Public Health Association. Standard Methods for the Examination of Water and Wastewater. 14th Edition. APHA; New York, New York. 1193 p. (1976).
2. Great Lakes Region Committee on Analytical Methods. "Chemistry Laboratory Manual for Bottom Sediments." U. S. Department of the Interior, Great Lakes Region; Chicago, Illinois. 96 p. (1968).

ORGANIC ANALYSIS

Carbamates

Chlorinated Phenoxy Acid Herbicides

Oil and Grease

Chlorinated Hydrocarbons

BHC

Lindane

Heptachlor

Aldrin

Heptachlor Epoxide

DDE

Dieldrin

Endrin

DDT

Chlorobenzilate

PCB

Malathion

Diazinon

Parathion

Organophosphorous Pesticides

Polynuclear Aromatic Hydrocarbons

Phenolics

CARBAMATES
(N-methylcarbamate Pesticides)

Carbamates have received increased usage because of the concern over the persistence of chlorinated hydrocarbons. Carbamates are more acutely toxic than chlorinated hydrocarbons but also degrade more rapidly.* These compounds generally attack the nervous system by deactivating the enzyme cholinesterase. A list of N-methylcarbamates, their chemical name, and producers is presented in Table 3-19.

Two methods are available for the quantification of carbamates. One method² involves extraction with methylene chloride, preparation of pentafluorobenzyl bromide derivatives, and quantification using a gas chromatograph with an electron capture detector. The second method utilizes the enzyme deactivation property of carbamates.¹ Samples are extracted and exposed to a cholinesterase substrate (3,3-dimethylbutyl acetate). The change in substrate activity is inversely proportional to the carbamate concentration of the sample. This method is nonspecific and noncarbamate compounds that inhibit enzyme activity will produce a positive interference.

Sample Collection and Storage

Samples should be collected in glass containers. The preferred method of sample treatment would be to extract immediately in the field. If this is not possible, samples should be shielded from exposure to sunlight and stored at 4°C. Samples should be extracted as soon as possible. A suggested flowchart for sample handling is presented in Figure 3-37.

Procedures for Water Samples (W1, W2, S1A)¹

Method 1: Methylene Chloride Extraction

* References can be found on page 3-259.

Table 3-19

Some N-methylcarbamates and Related Compounds*

Trade Name	Systematic Chemical Name*	Trade Source
Sevin ^R	1-Naphthalenyl-N-methylcarbamate	Union Carbide
Mesuro ^R	3,5-Dimethyl-4-(methylthio)-phenyl-N-methylcarbamate	Chemagro Corp.
Baygon ^R	2-(1-Methylethoxy)-phenyl-N-methylcarbamate	Chemagro Corp.
Landrin ^R	2,3,5-Trimethylphenyl-N-methylcarbamate	Shell Chemical Co.
Bux ^R	3-(1-Ethylpropyl) phenyl-N-methylcarbamate and 3-(1-Methylbutyl) phenyl-N-methylcarbamate	Chevron Chemical Co.
Mobam ^R	Benzo[b]thiophene-4-yl-N-methylcarbamate	Mobil Chemical
Carbofuran ^R	2,3-Dihydro-2,2-dimethyl-7-benzofuranyl-N-methylcarbamate	Niagara Chemical Co.
Temik ^R	2-Methyl-2-(methylthio) propanol-O-((methylamino) carbonyl) oxime	Union Carbide
Promecarb ^R	3-Methyl-5-(1-methylethyl)-N-methylcarbamate	Schering
Banol ^R	2-Chloro-4,5-dimethylphenyl-N-methylcarbamate	Upjohn Co.
Carzol ^R	N,N-Dimethyl-N'-(3-((methylamino) carbonyl) oxy) phenyl-methanimidamide monohydrochloride	NOR-AM Agriculture Products
Methomyl ^R	N-(((Methylamino)carbonyl) O-oxy)-ethanimidothioic acid-N-methylester	DuPont
Elocron ^R	2-(1,3-Dioxolan-2-yl)-phenyl-N-methylcarbamate	CIBA-Geigy Chemical Corp.
Dimetan ^R	5,5-Dimethyl-3-oxo-1-cyclohexen-1-yl-N-dimethylcarbamate	CIBA-Geigy Chemical Corp.
Butacarb ^R	3,5-Bis(1,1-dimethylethyl)phenyl-N-methylcarbamate	Niagara Chemical Co.

* Following Chemical Abstracts.

Figure 3-37. Handling and storage of samples for carbamate analysis

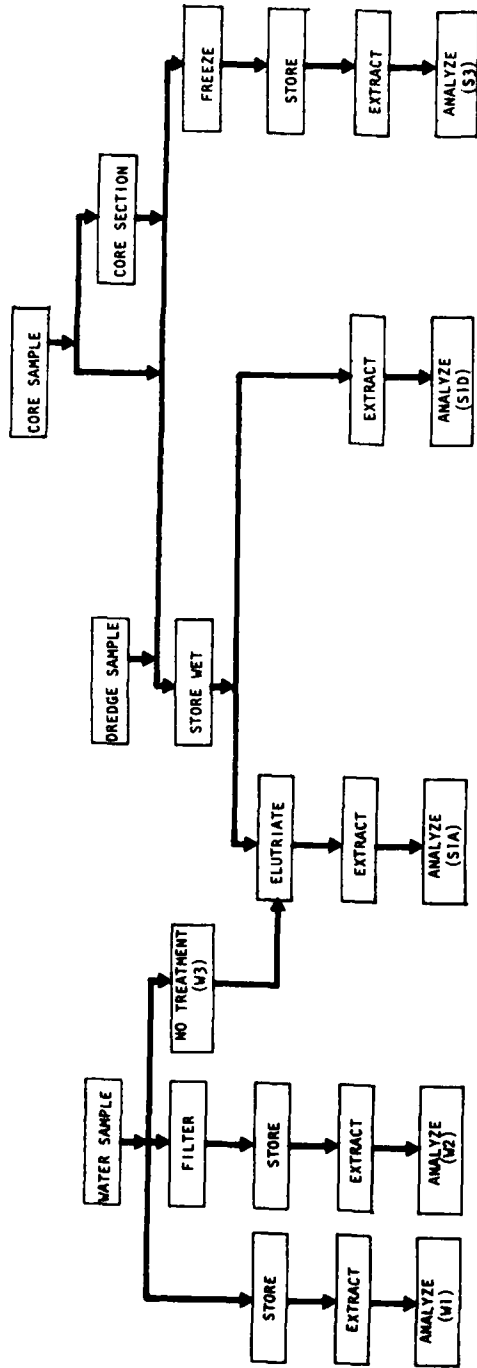

3-251

SAMPLE DESIGNATION	W1	W2	W3	S1A	S1D	S3
PURPOSE	Total Water Conc.	Soluble Water Conc.	Used In Elutriate	Mobile Conc.	Total Sediment Conc.	Total Sediment Conc.
CONTAINER	G	G	G	G	G	G
SAMPLE TREATMENT	None	Filter	None	None	None	Freeze
PRESERVATIVE	4 C	4 C	4 C	4 C (Minimize Air Contact. Keep Field Moist.)	4 C	None
STORAGE TIME	----- Not known with certainty. Process as soon as possible. -----					
DIGESTION SOLUTION	Methylene Chloride	Methylene Chloride	-	Methylene Chloride	Methylene Chloride	Methylene Chloride
SAMPLE VOLUME OR WEIGHT	0.1-1.0 liter	0.1-1.0 liter	-	0.1-1.0 liter	10 - 50 g	10 - 50 g

Apparatus

Water bath

Oxford pipettors

Centrifuge tubes

Vortex mixer

Gas chromatograph (GC), fid detector: column oven 215°C; detector 265°C; inlet 245°C; air 300 ml/min; hydrogen 20 ml/min; nitrogen 40 ml/min

GC column: a glass U-tube, 6 mm by 2 m (1/4 in. by 6 ft), packed with Chromsorb 101 (Johns Manville), mesh 80-100. Condition overnight at 250°C

Reagents

Stock buffer solution: dissolve 44.73 g KCl, 4.12 g sodium barbital, and 0.55 g K₂HPO₄ in 200 ml water.

Working buffer: add 20 ml stock buffer to 75 ml distilled water, adjust the pH to 8.0 with 0.1 N HCl, and dilute to 100 ml with distilled water.

Tween 20 (E) emulsifier.

3,3-dimethylbutyl acetate (DMBA): to remove butanol impurities from DMBA, mix 5 parts DMBA with 1 part acetic anhydride. Keep the mixture at 37°C for 24 hr and wash once with water to remove the acetic anhydride and impurities. Prepare a 0.2 M emulsion containing 0.2 percent emulsifier by diluting 0.72 g DMBA with 20 ml working buffer and adding 50 mg Tween 20 (R). Adjust the emulsion to a pH of 8 with NaOH and dilute to 25 ml with working buffer. Shake well before using. Store in refrigerator.

True cholinesterase, Type 1: Keep refrigerated. Add 3 ml working buffer to 50 µm units of enzyme.

Formic acid solution: dilute conc. (88 percent) HCHO with an equal volume of distilled water.

Bromine water: dilute 0.2 ml bromine with 100 ml distilled water.

Acetone, pesticide quality: redistill from glass.

Methylene chloride, pesticide quality: Wash with water, dry over anhydrous CaCl₂, and redistill from glass.

Carbon disulfide, Spectro AR Grade.

Stock parathion solution: dissolve 100 mg parathion in acetone and dilute to 100 ml. 1.00 ml = 1.00 mg. Store in refrigerator.

Standard parathion solutions: dilute the stock parathion solution with distilled water to prepare standards containing 25, 50, and 100 µg/ml. Store in refrigerator.

Procedure

Place 1.0 ml W1, W2, or S1A sample in a 15-ml centrifuge tube and add 1 ml methylene chloride. Shake the sample on a vortex mixer for 5 sec. Add 0.1 ml bromine water and shake an additional 5 sec. Remove the upper aqueous layer with a pipet and discard.

Transfer 10 μ l of the organic solvent layer to a second centrifuge tube as follows:

Place the tip of the pipettor below the liquid surface. Depress the plunger to the first stop and release 6 to 8 times to allow equilization of the partial pressure in the top so that the liquid will remain until expelled by fully depressing the plunger.

Evaporate the sample to dryness at 37°C. This is necessary to allow the carbamates to dissolve in the enzyme solution.

Add 100 μ l enzyme solution. Swirl and place in a 37°C water bath for 1 hr.

Transfer 10 μ l of sample to a clean centrifuge tube containing 1 ml pH 8 working buffer. Warm the tube to 37°C and add 0.2 ml DMBA emulsion. Incubate the tube at 37°C for 30 min.

Stop the reaction by adding 0.1 ml formic acid solution and 2 ml carbon disulfide. Stopper the tube and shake for 10 sec. After the layers separate, remove the aqueous layer with a pipet and discard.

Inject 5 μ l of the carbon disulfide layer into the gas chromatograph for determination of 3,3-dimethylbutanol (DMB) which will be eluted from the GC in approximately 2-1/2 min. The DMBA peak is eluted in approximately 4 min.

NOTE: The procedure depends on the conversion of DMBA to DMB. This is an enzymatic process that depends on the concentration of the enzyme, the concentration of the substrate, temperature, and pH. Therefore, careful attention to procedural detail is necessary for reproducibility.

Prepare a standard parathion curve by plotting parathion concentration vs. percent inhibition. Also, controls and blanks consisting of all reagents except the enzyme should be analyzed to determine whether nonenzymatic DMBA conversion is occurring.

Calculations

Determine the height of the DMB peak and calculate the percent inhibition caused by the sample as follows:

$$\% \text{ Inhibition} = \frac{(a - c) - (b - c)}{(a - c)}$$

where

a = height of control DMB peak

b = height of sample or standard DMB peak

c = height of blank DMB peak

Plot parathion concentration vs. percent inhibition on semilog paper and report the sample concentration based on the observed inhibition.

This procedure is considered tentative by Standard Methods. The results should be considered nonspecific as any compound that will hydrolyze DMBA to DMB is indirectly detected and all compounds are reported as an equivalent weight of the standard carbamate used.

Procedure for Sediment Samples (SID)^{2,3}

Method 1: Methylene Chloride Extraction

Apparatus

Gas chromatograph equipped with an electron capture detector

GC columns

- a. 3.6 percent (W/W) OV-101 + 5 percent (W/W) OV-210 on 80-100 mesh Chromosorb W, acid washed, DMCS treated
- b. 3 percent (W/W) OV-225 on 80-100 mesh Chromosorb W (HP)

Reagents

Prepare all reagent solutions in carefully cleaned glassware. Do not use any plastic ware in the preparation of reagents or the processing of samples.

Pentafluorobenzyl bromide (PFB) 1 percent (V/V) in acetone: store in dark container. Prepare every 2 weeks.

Methanolic potassium hydroxide - 10 percent (W/W): dissolve 10 g reagent grade potassium hydroxide in 100 ml pesticide grade methanol in dark bottle.

Potassium carbonate solution: (a) (0.1 M) 13.8 g K_2CO_3 in 1 l deionized distilled water; (b) 5 percent solution 10 g K_2CO_3 in 200 ml deionized distilled water.

50 percent sulphuric acid solution: extract two to three times with equal volumes of benzene.

Silica gel: deactivate by adding deionized distilled water, 1.5 percent (W/W). Store in tightly capped container. Coburn et al.³ specify grade 950 silica gel from Davison Chemical; Baltimore, Maryland 21226.

Anhydrous sodium sulphate.

Methylene chloride.

Benzene.

Isooctane (2,2,4-trimethylpentane).

5 percent Benzene-hexane (1:19).

25 percent Benzene-hexane (1:3).

75 percent Benzene-hexane (3:1).

Hexane.

Procedure

Weigh 30 g wet sediment. Extract sample with 1000 ml acidified ammonium acetate for 1 hr at 60°C. Place 1/2 of ammonium acetate extract (equivalent to 10 g sediment) in a 2-l separatory funnel.

Add sufficient 50 percent sulfuric acid to lower the extract pH to 3 to 4. Add 10 g sodium sulfate.

Extract the acidified solution twice with 150 ml methylene chloride. Shake the sample thoroughly for 10 min during each extraction. Combine the extracts and wash with 75 to 100 ml 0.1 M potassium carbonate for 5 min or less.

NOTE: The potassium carbonate may be retained for the analysis of phenols and other acidic compounds, if desired.

Pass the methylene chloride extract through a narrow anhydrous sodium sulfate column containing 20 g of the desiccant. Collect the sample in a round-bottomed flask. Rinse the column with 25 ml methylene chloride and add the rinse to the sample flask. Reduce the sample volume to approximately 5 ml using a rotary evaporator and a 40°C water bath.

Add 2 ml 10 percent methanolic potassium hydroxide to the methylene chloride concentrate. Allow the sample to hydrolyze overnight at room temperature.

Transfer the solution to a 500-ml separatory funnel using 50 ml deionized distilled water. Add 50 ml methylene chloride. Shake briefly and discard the methylene chloride layer.

Acidify the sample to pH < 2 with 50 percent sulfuric acid (approximately 0.3 to 0.5 ml). Extract the acidified sample extract with two 50-ml portions of pesticide grade benzene. Collect and combine the benzene extracts.

Prepare a narrow drying column containing 10 g anhydrous sodium sulfate. Apply the benzene extract to the column and collect in a round-bottomed flask. Evaporate the sample to approximately 1 ml using a rotary evaporator and a 40°C water bath.

Transfer the sample to a 15-ml graduated centrifuge tube. Rinse the round-bottomed flask with acetone and add to the centrifuge tube.

Add 20 µl 5 percent potassium carbonate and 100 µl 1 percent PFB reagent to the centrifuge tube. Stopper and shake thoroughly for at least 3 hr.

Add 2 ml isooctane to the derivatized sample and place in a 35° to 40°C water bath. Evaporate to approximately 1 ml by passing dry

nitrogen gas over the sample. Add a second 2-ml portion of isooctane and again reduce the volume to 1 ml.

Prepare a silica gel column with 1.5 percent water:silica gel in a disposable pipet. Place 5 g anhydrous sodium sulfate on top of the column.

Place the isooctane solution on the column. Rinse the centrifuge tube with 1 ml hexane and add to the column.

Elute the column with 5 ml 5 percent benzene:hexane. Discard the eluate.

Elute the column with 6 ml 25 percent benzene:hexane into a centrifuge tube. Analyze this fraction for Metmercapturon, Carboxyl, and Mobam using GC column a.

Elute the column with 8 ml 75 percent benzene:hexane into a second centrifuge tube. Analyze the fraction for Propoxin, Carbofuran, and Metmercapturon using GC column b.

Elute the column with 10 ml 100 percent benzene into a third centrifuge tube. Analyze for 3-Ketocarbofuran using GC column b.

Prepare standards with carbamates of interest.

Place mixed standards in a round-bottomed flask, add 5 ml methylene chloride and 2 ml 10 percent potassium hydroxide, and process as a sample from the hydrolysis step.

NOTE: Although the initial identification is based on GC analysis, it may be necessary to rely on mass spectrophotometry to identify the gas chromatographic peaks.

Calculations

Calculate the sediment concentration as follows:

$$M \text{ } \mu\text{g/kg (wet weight)} = \frac{A \times B \times C}{E \times F \times G}$$

$$M \text{ } \mu\text{g/kg (dry weight)} = \frac{A \times B \times C}{E \times F \times g \times \% S}$$

where

A = weight in picograms of standard

B = peak height (or area) of sample

C = volume of sample extract, ml

E = peak height (or area) of standard

F = volume of extract required to produce B, μ l

g = wet weight of sediment initially extracted, g
 $\% S$ = percent solids in sediment sample (expressed as a decimal fraction)
 M = concentration of methylcarbamate

References

1. American Public Health Association. Standard Methods for the Examination of Water and Wastewater. 14th Edition. APHA; New York, New York. 1193 p. (1976).
2. Walton, A. "Ocean Dumping Report 1. Methods for Sampling Analysis of Marine Sediments and Dredged Materials." Department of Fisheries and the Environment; Ottawa, Ontario, Canada. 74 p. (1978).
3. Coburn, J. A., Ripley, B. D., and Chan, A. S. Y. "Analysis of Pesticide Residues by Chemical Derivatization II, n-methyl carbamates in Natural Waters and Soils." Official Analytical Chemists Journal 59:188-196 (1976).

CHLORINATED PHENOXY ACID HERBICIDES

Chlorophenoxyacetic acids such as 2,4-dichlorophenoxyacetic acid (2,4-D), 2,4,5-trichlorophenoxyacetic acid (2,4,5-T), and silvex [2-(2,4,5-trichlorophenoxy) propionic acid] are herbicides used for weed control.^{1*} Each compound may exist as a free acid or an ester. In addition, the ester forms may hydrolyze in aquatic environments.²

The analytical procedure consists of three steps.^{1,3} Residues are extracted into an organic solvent and esterified using BF_3 . The methyl esters are then extracted into benzene and quantified using gas chromatography.

Sample Handling and Storage

Water samples should be collected in an all-glass system. The sample should be acidified with H_2SO_4 to $\text{pH} < 2$ immediately after collection and stored at 4°C in the dark. Extraction of the samples should begin within 12 hr of collection as the degradation of 2,4-D is rapid in aqueous systems.³

Sediment samples should be stored in glass or plastic containers. Immediate extraction of samples is recommended to minimize the effects of sample degradation. However, when necessary, sample freezing at -20°C has been shown to prolong the stability of 2,4-D.⁴

All sample containers should preferably be sealed with Teflon-lined screw caps.¹ An alternate method would be to use pre-cleaned, heavy-duty aluminum foil to prevent the sample from coming in contact with plastic caps and associated glue lining. The aluminum foil may be cleaned by washing in acetone, followed by rinsing with pesticide grade hexane.³

A flowchart for the processing of sediment and water samples to be analyzed for chlorinated phenoxy acid residues is presented in Figure 3-38.

* References for this section are found on page 3-277.

Figure 3-38. Handling and storage of samples for chlorophenoxy acetic acid analysis

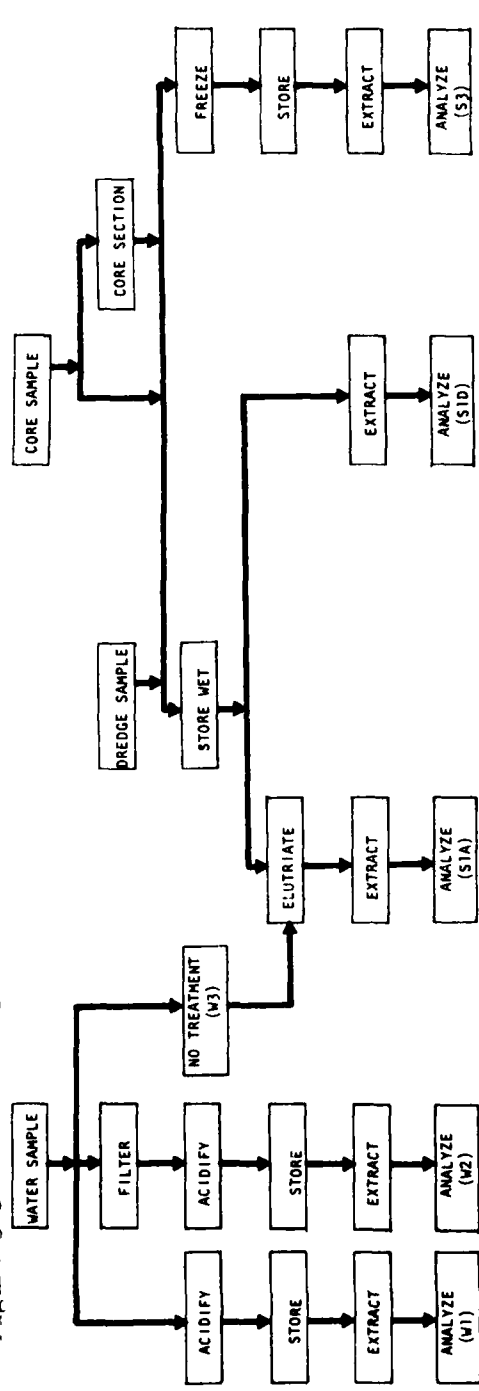

SAMPLE DESIGNATION	W1	W2	W3	S1A	S1D	S3
PURPOSE	Total Water Conc.	Soluble Water Conc.	Used In Elutriate	Mobile Conc.	Total Sediment Conc.	Total Sediment Conc.
CONTAINER	G	G	G	G	G	G
SAMPLE TREATMENT	None	Filter	None	None	None	Freeze
PRESERVATIVE	H ₂ SO ₄ to pH2 4°C	H ₂ SO ₄ to pH2 4°C	None	4°C (Minimize Air Contact. Keep Field Moist.)	4°C	None
STORAGE TIME	12 hr	12 hr	<1w	<1w	<1w	-
DIGESTION SOLUTION	Ethyl Ether or Chloroform	Ethyl Ether or Chloroform	-	Ethyl Ether or Chloroform	Ethyl Ether or Chloroform	Ethyl Ether or Chloroform
SAMPLE VOLUME OR WEIGHT	1 liter	1 liter	~2 liter	1 liter	10-20 g	10-20 g

Procedures for Water Samples (W1, W2, S1A)^{1,3}

Two extraction procedures are presented. The only differences in the procedures are the organic solvents used in the extraction step and the operating conditions of the gas chromatograph. The first procedure is a chloroform extraction and is used by Environment Canada.³ The second procedure is listed as tentative in the 14th Edition of Standard Methods.¹

Method 1: Chloroform Extraction³

Apparatus

All glassware must be washed in chromic acid, rinsed in dilute hydrochloric acid followed by distilled water, and then rinsed in acetone and hexane. Heat treatment is carried out at 300°C on all glassware except volumetric flasks and pipets. Care must be taken to ensure that the glassware is not alkaline. Considerable loss at low levels of herbicide can be attributed to the alkalinity of the glassware

Gas chromatograph such as a Varian 2800, Microtec 220, or equivalent. It should be equipped with an electron capture detector, a glass-lined injection port, and a recorder. Recommended operating conditions are: column temperature, 195°C; injection temperature, 250°C; detector temperature, 275°C; attenuation, 16; and carrier flow rate, 60 ml N₂/min

Chromatographic column: glass, 1.8 m by 4 mm I.D. One of the following four mixtures can be used as column packing to separate and quantify chlorinated phenoxy acid herbicides:

- a. McKinley and McGully's column (1964): 4 percent SE-30 and 6 percent QF-1 on 100-120 mesh size, chromosorb W, acid washed and DMCS treated
- b. 3 percent Dexil 300 GC on chromosorb W, acid washed and DMCS treated, 100-120 mesh size
- c. 3 percent OV-1 on chromosorb W, acid washed and DMCS treated, 100-120 mesh size
- d. Chau-Wilkinson Column (1972): 4 percent OV-101/6 percent OV-210 on chromosorb W, acid washed, HDMS treated, 80-100 mesh size

Pipets: Pasteur, disposable, 140 mm long; by 5 mm I.D., glass

Graduated centrifuge tubes: 15 ml with ground glass stoppers

Flasks: volumetric, 1.0, 2.0, 10, and 100 ml

Flasks: round bottomed, 300 ml

Evaporator, rotary

Micro-syringes: Hamilton, 10 μ l for injections

Oven (capable of maintaining 300°C)

Separatory funnels: 2-l and 500-ml sizes with TFE-fluorocarbon stop-cocks and taper ground glass stoppers, Kontes, or equivalent

Reagents

Check all reagents for purity by the gas chromatograph procedure. Much time and effort is saved by selecting high-quality reagents that do not require further preparation. Some purification of reagents may be necessary as outlined below. If more rigorous treatment is indicated, obtain the reagent from an alternate source.

Benzene: pesticide quality, distilled in glass.

Sodium sulfate, anhydrous, granular: store at 130°C.

Sodium sulfate solution: dissolve 50 ml anhydrous Na_2SO_4 in distilled water and dilute to 1 l.

Sodium sulfate, acidified: add 0.1 ml conc. H_2SO_4 to 100 g Na_2SO_4 slurried with enough ethyl ether to just cover the solid. Remove the ether by vacuum drying. Mix 1 g of the resulting solid with 5 ml distilled water and confirm that the mixture has a pH value below 4. Store at 130°C.

Sulfuric acid: H_2SO_4 , conc.

Boron trifluoride-methanol: 14 percent boron trifluoride by weight.

Florisil adsorbent: 60-100 mesh, factory activated at 650°C. The florisil is heated to 130°C for 1 hr and stored in a desiccator prior to use. Each batch is checked for activity and for contamination.

Glass wool: filtering grade, acid washed.

Analytical standards: MCPA; MCPA methyl ester; 2,4,5,-T; 2,4-D; 2,4,5-T methyl ester; 2,4-D methyl ester; silvex, silvex methyl ester; all at least 98+ percent purity (available from Dow Chemical).

Stock herbicide solutions: dissolve 100 g herbicide or methyl ester in 60 ml ethyl ether; dilute to 100 ml in a volumetric flask with hexane. 1.00 ml = 1.00 mg.

Intermediate herbicide solution: dilute 1.0 ml stock solution to 100 ml in a volumetric flask with a mixture of equal volumes of ethyl ether and benzene. 1.00 ml = 10.0 μ g.

Standard solution for chromatography: prepare final concentration of methyl ester standards in benzene solution according to the detector sensitivity and linearity.

Hexane.

Chloroform.

Methanol.

Procedure

Acidify a 1000-ml water sample to pH 2.0 with conc. H_2SO_4 . Transfer the sample to a 2000-ml separatory funnel.

Rinse the sample container with 50 ml chloroform and add the rinsing to the separatory funnel. Shake the mixture thoroughly for a minimum of 1 min. Allow 5 min for complete separation to occur and draw off the bottom chloroform layer into a clean 500-ml separatory funnel. Should an emulsion form during the extraction procedure, it can usually be broken by adding small quantities of 2-propanol, acetone, or a saturated NaCl solution.

Repeat the extraction a second and a third time using 50-ml portions of chloroform. Combine the extracts in the 500-ml separatory funnel. Wash the chloroform extract with 100 ml glass-distilled water. Remove the aqueous layer, making sure that it is slightly acidic.

Dry the combined chloroform extract over acidified sodium sulfate for 10 min. The extract should not remain in contact with the sodium sulfate layer for more than 1/2 hr.

Concentrate the dried extract on a rotary evaporator to a volume of approximately 5 ml. Add 10 ml of methanol and evaporate again to 5 ml. Continue this procedure until all traces of chloroform have been removed. Transfer the resultant methanol solution to a 15-ml graduated centrifuge tube and concentrate to 1 ml under a gentle stream of nitrogen.

Add 0.5 ml BF_3 -methanol complex to the sample in a graduated centrifuge tube and heat in a water bath at $50^\circ C$ for 30 min. Allow the reaction mixture to cool to room temperature.

Add 5 ml of 5 percent aqueous sodium sulfate solution to the centrifuge tube. Extract the methyl esters with two successive 2-ml portions of hexane. Concentrate the hexane extract to 1 ml under a stream of dry nitrogen.

Prepare a small column by plugging a disposable pipet with glass wool. Pack the column with 2.0 cm of florisil and 2.0 cm neutral anhydrous sodium sulfate. Pass the hexane phase containing the methyl esters of the phenoxy acid herbicides through the column. Elute the herbicides with 10 ml of benzene.

Concentrate the benzene solution to 0.5 ml under a stream of dry nitrogen and quantitatively transfer the solution to a 1-ml volumetric flask. This solution is now ready for quantification using gas chromatography.

Preliminary identification is achieved via electron capture GLC using at least two different stationary phases of different polarity. The identity of the herbicide is based on the retention time relative to aldrin.

Confirmation of residue identity may be achieved by one of the following methods:

- a. Transesterification to higher molecular weight esters.⁵
- b. Thin-layer chromatography utilizing silica gel G as the absorbent and benzene as the mobile phase. Development can be achieved using a silver nitrate spray reagent.⁶
- c. Mass spectroscopy.

Calculations

The concentration of chlorinated phenoxy acid herbicides in the water sample is calculated as:

$$P = \frac{A \times B \times C}{E \times F \times G} \times 10^{-3}$$

where

P = concentration of chlorinated phenoxy acid herbicides, $\mu\text{g}/\ell$

A = weight in picograms of standard

B = peak height (or area) of sample

C = volume of sample extract, ml

E = peak height (or area) of standard

F = volume of extract required to produce B, μl

G = volume of water sample initially extracted, ℓ

Method 2: Ethyl Ether Extraction¹

Apparatus

Gas chromatograph such as a Varian 2800, Microtec 220, or equivalent.

It should be equipped with an electron capture detector, a glass-lined injection port, and a recorder. The following operating conditions are recommended: injection temperature, 215°C; oven temperature, 185°C; column temperature, 185°C; and a carrier gas flow of 70 ml/min in a 6.4 mm-O.D. column

Chromatographic column: the use of two columns is suggested for

identification and confirmation. One column is packed with 1.5 percent OV-17 and 1.95 percent QF-1 on a 100/120 mesh Gas Chrom Q. The second column is packed with 5 percent OV-210 on a 100/120 mesh Gas Chrom Q.

Pipets: Pasteur, disposable, 140 mm long, by 5 mm I.D., glass

Micro-syringes: Hamilton, 10 μ l for injections

Oven (capable of maintaining 300°C)

Evaporator concentrator: Kuderna-Danish, 250-ml flask and 5-ml volumetric receiver, Kontes or equivalent

Snyder columns: three-ball macro, one-ball micro

Separatory funnels: 2-l and 60-ml sizes with TFE-fluorocarbon stopcocks and taper ground glass stoppers, Kontes, or equivalent

Sand bath: fluidized (TeCam or equivalent) or water bath

Erlenmeyer flask: 250 ml, with ground glass mouth to fit Snyder columns

Reagents

Check all reagents for purity by the gas chromatograph procedure.

Much time and effort is saved by selecting high-quality reagents that do not require further preparation. Some purification of reagents may be necessary as outlined below. If more rigorous treatment is indicated, obtain the reagent from an alternate source.

Ethyl ether: reagent grade. Redistill in glass after refluxing over granulated sodium-lead alloy for 4 hr.

Benzene: pesticide quality, distilled in glass.

Sodium sulfate: anhydrous, granular. Store at 130°C.

Sodium sulfate solution: dissolve 50 ml anhydrous Na_2SO_4 in distilled water and dilute to 1 l.

Sodium sulfate, acidified: add 0.1 ml conc. H_2SO_4 to 100 g Na_2SO_4 slurried with enough ethyl ether to just cover the solid. Remove the ether by vacuum drying. Mix 1 g of the resulting solid with 5 ml distilled water and confirm that the mixture has a pH value below 4. Store at 130°C.

Sulfuric acid: H_2SO_4 , conc.

Sulfuric acid, H_2SO_4 , 9 N: store in refrigerator.

Potassium hydroxide solution: dissolve 37 g KOH in distilled water and dilute to 100 ml.

Boron trifluoride-methanol: 14 percent boron trifluoride by weight.

Florisil adsorbent: 60-100 mesh, factory activated at 650°C. The florisil is heated to 130°C for 1 hr and stored in a desiccator prior to use. Each batch is checked for activity and for contamination.

Glass wool: filtering grade, acid washed.

Analytical standards: MCPA; MCPA methyl ester; 2,4,5-T; 2,4-D; 2,4,5-T methyl ester; 2,4-D methyl ester; silvex; silvex methyl ester; all at least 98+ percent purity (available from Dow Chemical).

Stock herbicide solution: dissolve 100 mg herbicide or methyl ester in 60 ml ethyl ether; dilute to 100 ml in a volumetric flask with hexane. 1.00 ml = 1.00 mg.

Intermediate herbicide solution: dilute 1.0 ml stock solution to 100 ml in a volumetric flask with a mixture of equal volumes of ethyl ether and benzene. 1.00 ml = 10.0 µg.

Standard solution for chromatography: prepare final concentration of methyl ester standards in benzene solution according to the detector sensitivity and linearity.

Procedure

Measure 1 l of a W1 or W2 sample using a graduated cylinder. Acidify to pH 2 with conc. H_2SO_4 and transfer to a 2-l separatory funnel. Add 150 ml ethyl ether to the separatory funnel and shake vigorously for 1 min. Let phases separate for 10 min. If emulsions form, drain off the aqueous layer, invert the funnel, and shake rapidly. NOTE: Vent the funnel frequently to prevent excessive pressure buildup.

Collect the extract in a 250-ml ground glass-stoppered Erlenmeyer flask containing 2 ml KOH solution. Repeat the extraction with two 50-ml portions of ethyl ether. Combine the extracts in the Erlenmeyer flask.

Add 15 ml distilled water and a small boiling stone to the flask. Attach a three-ball Snyder column. Remove the ether on a steam bath and continue heating for a total of 60 min.

Transfer the concentrate to a 60-ml separatory funnel. Extract the sample with 20 ml ethyl ether and discard the ether layer. Repeat the ether extraction and again discard the ether layer. The herbicides are retained in the aqueous phase.

Acidify with 2 ml cold (4°C) 1+3 H_2SO_4 . Extract once with 20 ml ethyl ether and twice with 10 ml ethyl ether. Collect the extracts in a 125-ml Erlenmeyer flask containing 0.5 g acidified anhydrous Na_2SO_4 . Let the extract remain in contact with the Na_2SO_4 for at least 2 hr.

Fit a Kuderna-Danish apparatus with a 5-ml volumetric

receiver. Transfer the ether extract to the Kuderna-Danish apparatus through a funnel plugged with glass wool. Use liberal washing of ether. Crush any hardened Na_2SO_4 with a glass rod. Before concentrating, add 0.5 ml benzene.

Reduce the volume to less than 1 ml on a sand bath or on a steam bath heated to 60° to 70°C . Attach a Snyder microcolumn to the Kuderna-Danish receiver and concentrate to less than 0.5 ml.

Cool and add 0.5 ml boron trifluoride-methanol reagent. Use the small one-ball Snyder column as an air-cooled condenser and hold the contents of the receiver at 50°C for 30 min in the sand bath. Cool and add enough Na_2SO_4 solution so that the benzene-water interface is in the neck of the Kuderna-Danish volumetric receiver flask (about 4.5 ml). Stopper the flask with a ground-glass stopper and shake vigorously for about 1 min. Let stand for 3 min for phase separation.

Pipet the solvent layer from the receiver to the top of a small column prepared by plugging a disposable Pasteur pipet with glass wool and packing with 2.0 cm Na_2SO_4 over 1.5 cm florisil adsorbent. Collect the eluate in a 2.5-ml graduated centrifuge tube. Complete the transfer by repeatedly rinsing the volumetric receiver with small quantities of benzene until a final volume of 2.0 ml of eluate is obtained. Check calibration of centrifuge tubes to ensure that the graduations are correct.

Analyze the benzene extract by gas chromatography using at least two columns. Injections of 5 to 10 μl should be sufficient for this purpose.

Inject standard herbicide methyl esters frequently to ensure optimum operating conditions. Always inject the same volume. Adjust the volume of sample extract with benzene, if necessary, so that the heights of the peaks obtained are close to those of the standards. (If a portion of the extract solution was concentrated, the dilution factor D is less than 1; if it was diluted, the dilution factor exceeds 1.)

The identity of the residue may be confirmed by:

- a. Transesterification.
- b. Thin-layer chromatography.

c. Mass spectroscopy.

Calculations

Compare the peak height of a standard to the peak height of the sample to determine the amount of the herbicide injected.

Calculate the concentration of herbicides:

$$\mu\text{g}/\ell = \frac{A \times B \times C \times D}{E \times F \times G}$$

where

A = weight of herbicide standard injected

B = peak height of sample, mm

C = extract volume, μl

D = dilution factor

E = peak height of standard, mm

F = volume injected, μl

G = volume of sample extracted, ml

To determine recovery efficiency, add known amounts of herbicides to a 1- ℓ water sample, carry through the same procedure as the samples, and determine recovery efficiency. Periodically determine recovery efficiency and a control blank to test the procedure. Analyze one set of duplicates with each series of samples as a quality control check.

NOTE 1: Extraneous matter, especially in highly colored water samples, is a potential interference. The cleanup procedure described here will usually eliminate this source of interference. Many organic compounds can interfere with the analysis, however. Boron trifluoride-methanol reagent is used to advantage because it reacts specifically with carboxylic acids, whereas diazomethane may react with phenols and other organics with relatively active hydrogens. All reagents must be thoroughly checked and any interferences from this source eliminated.

NOTE 2: Strict attention is required of the analyst to obtain reproducible and satisfactory recovery. In the steps where solvents are evaporated, extreme care must be exercised, especially when working with the methyl esters. The extracts should never be taken to dryness as the esters are extremely volatile.

NOTE 3: Care must be taken to ensure that the tubes are tightly capped and remain so after introduction of the BF_3 -methanol reagent. The temperature should be about 50°C for good yields. The methylation is a very critical step in the procedure.

NOTE 4: Sodium sulfate has been questioned due to its relative retentive property for 2,4-D. However, if that reagent is not basic, the recoveries are good.

Procedure for Sediment Samples (SLD, S3)^{7,8}

Method 1: Acetone-Hexane Extraction

Apparatus

Gas chromatograph equipped with an electron capture detector and a recorder. Operating conditions are: column temperature, 200°C; injection port, 230°C; and detector temperature, 340°C. Use 5 percent methane and 95 percent argon for both carrier gas flow (40 ml/min) and make-up gas flow (20 ml/min)

Chromatograph column, glass U-Tube, 2 m by 3.5 mm O.D.

Two column packings have been shown to be useful for separating and quantifying chlorinated phenoxy acid herbicides:

- a. 11 percent OV17 + QF-1 mixed phase by weight on 80/100 mesh Gas Chrom Q available from Applied Science
- b. 3 percent QV17 on Chromosorb W, HP 80/100 mesh available from Applied Science

Ultrasonic homogenizer: such as the Sonicator Cell Disruptor Model W-375 with a solid disruptor form (#280-0.75"). This is available from Heat Systems-Ultrasonic, Inc., 38 East Mall, Plainview, Long Island

Solvent evaporator: such as the Bichi Rotovap

Centrifuge tube heater: such as the Kontest Tube Heater block set at 40°C combined with a gentle stream of pure N₂ gas for controlled evaporation

All glassware must be thoroughly washed with laboratory soap, rinsed with tap H₂O, and rinsed with diluted HCl, followed by distilled H₂O, acetone, and hexane. Heat treatment is carried out at 300°C on all glassware except volumetric flasks and disposable pipets

NOTE: Glassware must be acidic. Considerable loss at low levels of herbicide can be attributed to alkalinity of the glassware.

Oven: capable of maintaining 300°C

Pipets: disposable

Beakers: 100 ml

Beakers: 200 ml

Tubes: graduated centrifuge, glass with ground-glass stopper

Flasks: flat bottomed, 500 ml

Funnels: coarse, sintered glass, with ground-glass joints

Flasks: suction with ground-glass joints

Funnels: separatory, 500 ml

Funnels, powder: glass

Column: chromatographic (10 mm I.D. x 300 mm) with coarse frit and stopcock. Reservoir at top (28 mm I.D. x 150 mm)

Syringe: Hamilton, injection, 10 μ l

Reagents

All solvents must be of pesticide quality and should be checked before use. All chemicals must be of highest purity and should be suitably pretreated as required.

Benzene.

Hexane.

Methylene Chloride.

Acetone.

1:1 Acetone:Hexane

Acidified organic-free H₂O: add hexane (50 ml) to distilled H₂O (5 l) and stir for 4 hr on a magnetic stirrer at maximum speed. Transfer to a large separatory funnel and remove the water layer into storage bottles. Add conc. HCl (2 ml/l).

HCl, conc. (analyzed reagent grade or better).

Celite filter aid.

Silica gel ignited at 650°C overnight, homogenized with 5 percent organic-free water for 2 hr prior to use.

Anhydrous sodium sulfate (ASC grade or better) ignited at 650°C overnight.

Acidic sodium sulfate: acidify acetone (250 ml) with conc. HCl to pH 4. Place ignited Na₂SO₄ into a clean porcelain tray and homogenize with the acetone solution. Allow to dry overnight in a fumehood. Place in storage bottles.

5 percent Na₂SO₄ solution: dissolve heat-treated Na₂SO₄ (50 g) in organic-free H₂O and dilute to 1 l.

Analytical standards: 2,4-DP; 2,4-D; 2,4,5-T; silvex and 2,4-DB acids and esters, all 99+ percent pure (available from Polyscience or as Environmental Protection Agency reference standards).

Boron trifluoride (14 percent)-methanol complex esterification reagent (available from Analabs).

Procedure

Weigh a 25-g dry weight equivalent of a homogenized S1D or S3 sediment sample. Transfer to a 250-ml beaker and slurry with acidified organic-free water. The resultant mixture should be approximately 20 to 30 percent water.

Thoroughly mix the sediment slurry and carefully acidify the sample with 4 ml conc. hydrochloric acid.

NOTE: Add acid slowly with mixing to prevent mechanical loss due to gas expulsion. Allow the mixture to sit 20 min, stirring occasionally.

Add 5 ml 1:1 acetone:hexane mixture to the acidified sediment. Place the ultrasonic homogenizer disruptor horn approximately 2 cm into the sample. Activate the disruptor for 2 min in the pulsed mode at 35 percent duty cycle with maximum output. Allow the sediment to settle.

Prepare a slurry of 1:1 acetone/hexane and celite. Pour the slurry into a sintered glass funnel which is connected to a suction flask. Activate vacuum to remove the acetone/hexane from the celite filter bed. Discard the acetone/hexane.

Decant the supernatant solvent from the sample into the funnel and apply a vacuum to collect the extract in the suction flask. Retain the solids for a second extraction.

Add 75 ml 1:1 acetone:hexane to the sediment. Mix with the ultrasonic homogenizer, allow the sediment to settle, and filter through the celite filter bed.

Transfer the combined extract to a 50-ml separatory funnel. Add 100 ml acidified organic-free water and shake for 1 min. Release the pressure frequently. Allow the layers to separate and transfer the aqueous layer back to the suction flask.

Slowly pour the solvent layer through a glass powder funnel plugged with glass wool and containing approximately 2 cm of acidic Na_2SO_4 . Trap the solvent in a 500-ml flat-bottomed flask.

Return the aqueous layer from the suction flask to the separatory funnel. Rinse the suction flask with 75 ml methylene chloride and add the rinses to the separatory funnel. Shake for 1 min and allow the layers to separate.

NOTE: If an emulsion persists, leave it with the aqueous layer.

Decant the lower solvent layer through the Na_2SO_4 funnel and into the 500-ml flat-bottomed flask.

Extract the aqueous phase with a second 75-ml portion of

methylene chloride. Filter the methylene chloride phase through the acidified Na_2CO_3 funnel and combine with previous extracts.

NOTE: There should not be any H_2O in the extract.

Transfer the extract to a Büchi evaporator and reduce the volume to 2 to 5 ml. Transfer the residue to a 15-ml graduated centrifuge tube and evaporate to 0.5 ml.

Add 1 ml of benzene and shake. Reduce the volume to 0.5 ml. Repeat the process of adding 1 ml of benzene and reducing the volume to 0.5 ml until the extracted residue is in benzene and methylene chloride has been removed.

Add 0.2 ml 15 percent boron trifluoride-methanol esterification reagent and shake for 1 min. Seal tightly and place the tube in a water bath at 50°C for 30 min.

Cool to room temperature and add 5 ml 5 percent Na_2CO_3 solution. Shake for 1 min and allow the layers to separate.

Withdraw the top layer into a clean centrifuge tube using a Pasteur pipet. Add 1 ml benzene and shake. Allow the layers to separate and transfer the top benzene layer to a clean centrifuge tube. Repeat the benzene extraction a second and a third time.

Evaporate the final benzene extract to a volume of 0.5 ml. Add 1 ml hexane, shake, and reduce the volume to 0.5 ml. Repeat this process an additional two times to bring the extract into hexane.

Prepare a cleanup column by adding preheated silica gel to a height of 75 mm. Tap the column while packing. Add 12 mm of neutral anhydrous Na_2CO_3 to the top of the column. Elute the column with approximately 50 ml of hexane and discard the eluant.

Carefully transfer the 0.5-ml hexane residue to the cleanup column. Rinse the centrifuge tube with three 1-ml portions of hexane and add each rinsing to the cleanup column. Allow the column to elute until the hexane layer just recedes to the top of the Na_2CO_3 .

Add 90 ml of hexane and elute. Discard the eluant.

Add 100 ml benzene and elute. Collect the solvent in a 100-ml flat-bottomed flask. Elute with a second 100-ml portion of benzene and combine with the first eluant. Reduce the volume to approximately 5 ml on a Büchi evaporator. Transfer to a 10-ml volumetric flask

and dilute to volume with benzene.

Preliminary identification is achieved via electron capture GC in which at least two different stationary phases of different polarity are employed. The identity of the herbicide is based on the retention time relative to alrin.

Confirmation can be achieved by transesterification, thin-layer chromatography, or mass spectroscopy.

Calculations

The concentration of chlorinated phenoxy acid herbicides in the sediment sample can be calculated as:

$$C = (\text{wet weight}) = \frac{A \times B \times C}{H \times V \times H}$$

$$C = (\text{dry weight}) = \frac{A \times B \times C}{F \times V \times H \times D, T}$$

where

- C = concentration of chlorinated phenoxy acid herbicides, $\mu\text{g}/\text{kg}$
- A = weight in picograms of standard
- B = peak height (or area) of sample
- V = volume of sample extract, ml
- H = peak height (or area) of standard
- F = volume of extract required to produce B, μl
- D = wet weight of sediment initially extracted, g
- T = percent solids in sediment sample (expressed as a decimal fraction).

Remarks

Great attention is required of the analyst to obtain reproducible and satisfactory recovery. In the steps where solvents are evaporated, extreme care must be exercised, especially when working with the methyl esters. The extracts should never be taken to dryness as the herbicides are extremely volatile.

In natural sediment samples, benzene elutes brown matter which, upon HPLC injection, remains in the column sleeve throughout its chromatographic run.

When emulsions form at the solvent/liquid interface, the emulsion droplets remain with the H₂O phase. This allows the emulsion to be extracted further with methylene chloride and prevents the H₂O

in the funnel from becoming saturated with water.

Any amount of water in the extract could inhibit esterification and result in depressed recoveries.

The procedure has been shown to produce greater than 90 percent recoveries with known standards. The presence of organic matter in samples can reduce recoveries.

References

1. American Public Health Association. Standard Methods for the Examination of Water and Wastewater Including Bottom Sediments and Sludges. 14th Edition. APHA; New York, New York. 1193 p. (1976).
2. Funk, G. A., Richard, J. J., Fritz, J. S., and Svec, H. J. "Resin Sorption Methods for Monitoring Selected Contaminants in Water." In: Identification and Analysis of Organic Pollutants in Water. L. H. Keith (Ed.). Ann Arbor Science Publishers; Ann Arbor, Michigan. pp. 135-153 (1976).
3. Environment Canada. "Analytical Methods Manual." Inland Waters Directorate, Water Quality Branch; Ottawa, Ontario, Canada (1974).
4. Bristol, D. "Effects of Storage Conditions of Residues of 2,4-D and 2,4-DCP in Potatoes." In: "Accuracy in Trace Analysis: Sampling, Sample Handling, and Analysis." National Bureau of Standards Special Publication 422. pp. 737-745 (1976).
5. Yip, G. "Confirmation of Chlorophenoxy Acid Herbicide Residues by Transesterification." *J. Assn. Offic. Anal. Chem.* 54:343-34 (1971).
6. Chau, A. S. Y. "Analysis of Chlorinated Hydrocarbon Pesticides in Waters and Wastewaters. Methods in Use in Water Quality Division Laboratories." Department of the Environment, Inland Waters Directorate; Ottawa, Ontario, Canada (1972).
7. Walton, A. "Ocean Dumping Report I. Methods for Sampling and Analysis of Marine Sediments and Dredged Materials." Department of Fisheries and Environment; Ottawa, Ontario, Canada. 74 p. (1978).
8. Peake, A. A., and Lesick, H. S. "Procedure for the Analysis of Phenoxy Acid Herbicides in Sediments." Water Quality Branch, Inland Waters Directorate; Calgary, Alberta, Canada. 9 p. (No date).

OIL AND GREASE

The oil and grease procedure is a gross measurement of a fraction of the organic material that may be present in water and sediment samples.^{1*} The procedure is operationally defined and based on the solubility of organic matter in a nonpolar solvent under acidic conditions. Therefore, specific compounds that may be included in an oil and grease determination are hydrocarbons, vegetable oils, animal fats, waxes, soaps, greases, and related industrial compounds.^{1,2}

Sample Handling and Storage

The oil and grease procedure can be performed with either water or sediment samples. However, the test should not be run on filtered water samples as part of the oil and grease can be lost during the filtration process.³ If it is desired to estimate the dissolved oil and grease fraction, a separate water sample or a separate elutriate preparation should be centrifuged. Samples should be collected and stored in glass containers and preserved with sulfuric acid (pH < 2).

Sediments may lose apparent oil and grease as a result of drying. Therefore, it is recommended that sediments to be analyzed for oil and grease be stored in a field moist condition at 4°C. A schematic flowchart for oil and grease sample handling is presented in Figure 3-39.

Procedure For Water Samples (W1, W2, S1A)

Method 1: Free Extraction^{1,2}

Apparatus

Separating Funnel, 2000 ml, with Teflon stopcock

Extraction apparatus, Soxhlet

Distilling flask, 100 ml

Water bath

Infrared spectrophotometer, double beam, recording and quartz cells

* References can be found on page 3-288.

Figure 3-39. Handling and storage of samples for oil and grease analysis

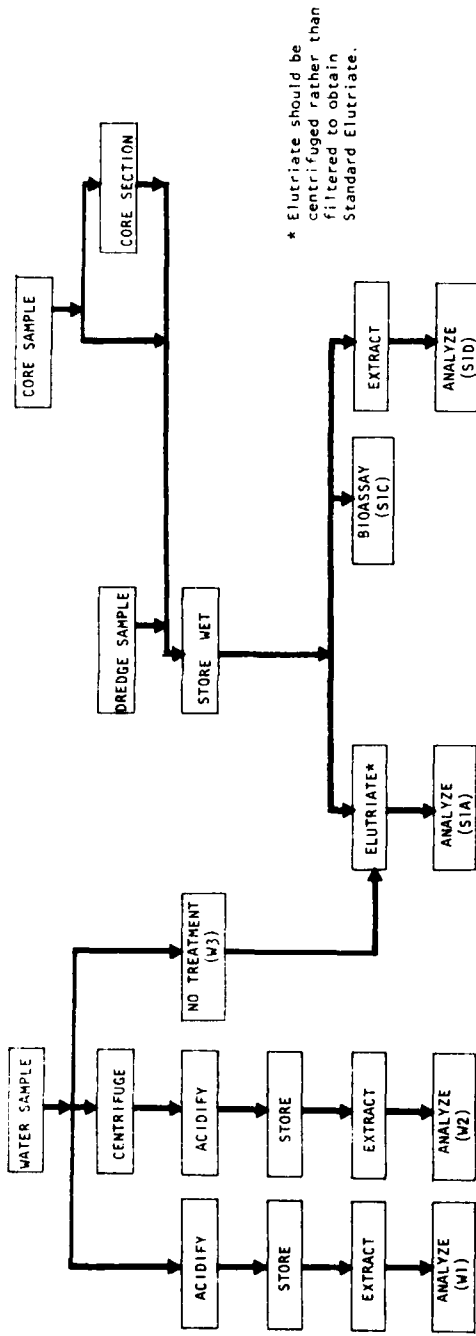

SAMPLE DESIGNATION	W1		W2		W3		S1A		S1C		S1D	
	Total Water Conc.	Soluble Water Conc.	Centrifuge	Used in Elutriate	Mobile Conc.	Bioavailability	Total Sediment Conc.					
PURPOSE	G	G	None	None	G	G	G					
CONTAINER	None	None	None	None	None	None	None					
SAMPLE TREATMENT	H ₂ SO ₄ , pH<2	H ₂ SO ₄ , pH<2	Centrifuge	None	4°C	4°C	4°C					
PRESERVATIVE	1W	1W	1W	1W	1W	1W	1W					
STORAGE TIME	Freon	Freon	Freon	Freon	Freon	Freon	Freon					
DIGESTION SOLUTION	1 liter	1 liter	1 liter	1 liter	1 liter	1 liter	20g					
SAMPLE VOLUME OR WEIGHT	1 liter	1 liter	1 liter	1 liter	1 liter	1 liter	20g					

Balance

Reagents

Either 1:1 sulfuric acid or 1:1 nitric acid: mix equal volumes of the concentrated acid and distilled water.

Freon 113, b.p. 48°C; 1,1,2-trichloro-1,2,2-trifluoroethane: filter 1-gal quantities through paper into glass containers. The solvent should leave no measurable residue on evaporation. Solvent blanks should be run routinely as a quality control check. Redistill the solvent when necessary.

Sodium sulfate, Na₂SO₄, anhydrous crystal.

Known oil reference standard: accurately weight about 0.05 g of known oil directly into a 100-ml volumetric flask. Add 80 ml Freon and dissolve the oil. If, as in the case of a heavy fuel oil, all the oil does not go into solution, let stand overnight. Filter through a Whatman No. 40 filter paper into a second 100-ml volumetric flask and dilute to volume with Freon.

Unknown oil reference standard (10 µl = 7.69 mg oil): pipet 15.0 ml n-hexadecane, 15.0 ml isooctane, and 10.0 ml benzene into a 50-ml glass-stoppered bottle. Assume the specific gravity of this mixture to be 0.769 and maintain the integrity of the mixture by keeping the bottle stoppered except when withdrawing aliquots.

Procedure

Mark the liquid level on the sample container for later determination of sample volume. If the sample was not acidified at the time of collection, add 5 ml of sulfuric acid or hydrochloric acid to the sample bottle. Mix the sample and measure the pH to ensure that the pH is 2 or lower. Add additional acid if necessary.

Transfer approximately 1 ℓ of unfiltered water or centrifuged water sample into a separating funnel. Rinse the sample container with 30 ml Freon 113 and add the solvent washings to the separating funnel. Shake the separating funnel vigorously for 2 min and allow the layers to separate.

Soak a Whatman No. 40 filter in Freon 113 and mount in a funnel. Drain the Freon layer from the separating funnel through the solvent-moistened filter paper and into a clean collection vessel.

Rinse the original sample container with a second 30-ml portion of Freon, add the washings to the sample in the separatory funnel, and extract a second time. Drain the organic layer through the filter paper and combine with the first extract. Repeat the entire

procedure with a third 30-ml portion of Freon.

The final combined extract should be a clear solution. If an emulsion has formed, add approximately 1 g anhydrous sodium sulfate, Na_2SO_4 , to the funnel cone and refilter the combined extract. Use additional sodium sulfate as required.

Rinse the tip of the separating funnel, the filter paper, and the funnel with 10 to 20 ml Freon. Collect the washings and add to the sample extract in the collection vessel.

The extracted material can be quantified as oil and grease using one of the following methods: (a) infrared spectrophotometry or (b) gravimetry.

- a. Infrared spectrophotometry.^{1,2} If this method of quantification is to be used, it would be convenient to collect the sample extracts and washings in a 100-ml volumetric flask. Dilute the combined extracts to volume with Freon.

Prepare calibration standards using either the known oil reference standard or the unknown oil reference standard. (A known oil is defined as the only grease and/or oil component in the samples being analyzed. An unknown oil is defined as the grease and/or oil component(s) in the sample being analyzed for which standard preparations are not available.) Transfer required amounts of the appropriate reference material into 100-ml volumetric flasks using microliter pipets. Dilute to volume with Freon.

The most appropriate pathlength for the quartz cells to be used in the spectrophotometric determination is determined by the expected sample concentration. The following information is presented as a guide to selecting cells:

<u>Pathlength, cm</u>	<u>Expected Range, mg</u>
1	4 - 40
5	0.5 - 8
10	0.1 - 4

Scan the standards and samples from 3200 to 2700 cm^{-1} using a recording infrared spectrophotometer. Freon should be used in the reference beam or to zero the instrument. The maximum absorbance at 2930 cm^{-1} should be used to construct a standard curve. The most useful curve would be a plot of absorbance vs. mg oil as determined by dilution of the standard reference solutions.

- b. Gravimetry.¹ Transfer the water extract from the collection vessel to a tared distillation flask. Rinse the

collection vessel with Freon and add the washing to the distillation flask. Distill off the solvent using a water bath at 70°C. After the solvent has been evaporated, place the flask on a warm steam bath for 15 min. During the final minute on the steam bath, draw air through the flask by means of an applied vacuum. Cool the flasks in a desiccator for 30 min and weigh. The gain in weight of the tared flask is attributable to oil and grease if the Freon is free of residue.

Calculations

Select the appropriate method and calculate the oil and grease concentration based on the method of quantification that was used.

- a. Infrared spectrophotometry. When colorimetry is used, prepare a standard curve by plotting measured absorbance versus oil and grease concentration of the standards. Compare the absorbance of the Freon extract to the standard curve to determine the oil and grease concentration.

Calculate the oil and grease concentration O + G of the original water sample as follows:

$$O + G \text{ mg/l} = \frac{(X)(V)}{S}$$

where

X = the concentration of oil and grease in the Freon extract, mg/l

V = the volume of Freon extract, l

S = the volume of sample extracted, l. This is determined by refilling sample collection bottle to the mark and measuring the required volume in liters. This volume should be corrected for any acid added as a preservative.

- b. Gravimetry. When the amount of oil and grease is determined by weighing the material extracted, the sample concentration is determined as follows:

$$O + G \text{ mg/l} = \frac{(A - B - C)}{S}$$

where

A = weight of tared flask and oil and grease residue, mg

B = weight of tared flask, mg

C = calculated residue based on Freon blank, mg

S = volume of water initially extracted, l. This is determined by refilling sample collection bottle

to the mark and measuring the required volume
in liters. This volume should be corrected for
any acid added as a preservative.

Procedure for Sediment Samples (SID)

The procedure for determination of oil and grease in sediment samples is similar to that used to quantify oil and grease in water samples. The sample is extracted with Freon and the extractable material is quantified. As indicated in Figure 3-39, a moist sediment sample must be used as a dried sample will yield low results. Because of the operational definition of the oil and grease procedure and the lack of precision associated with the test, it is recommended that conditions of sampling, sample pretreatment, and analysis be standardized to ensure comparability of the final data.³

Method 1: Freon Extraction¹

Apparatus

Extraction apparatus, Soxhlet
Vacuum pump or other source of vacuum
Extraction thimble, paper
Infrared spectrophotometer or balance

Reagents

Either conc. hydrochloric acid, HCl, or conc. sulfuric acid, H₂SO₄.
Magnesium sulfate monohydrate: prepare MgSO₄ · H₂O by drying a thin layer of MgSO₄ · 7H₂O overnight in an oven at 103°C.
Freon (1,1,2-trichloro-1,2,2-trifluoroethane), boiling point 47°C. The solvent should leave no measurable residue on evaporation. Redistill if necessary.
Grease-free cotton: extract nonabsorbent cotton with Freon.
Known oil reference standard: accurately weigh about 0.05 g of known oil directly into a 100-ml volumetric flask. Add 80 ml Freon and dissolve the oil. If, as in the case of a heavy fuel oil, all the oil does not go into solution, let stand overnight. Filter through a Whatman No. 40 filter paper into a second 100-ml volumetric flask and dilute to volume with Freon.
Unknown oil reference standard (10 µl = 7.69 mg oil): pipet 15 ml n-hexadecane, 15 ml isooctane, and 10 ml benzene into a 50-ml glass-stoppered bottle. Assume the specific gravity of this mixture to be 0.769 and maintain the integrity of the mixture by keeping the bottle stoppered except when withdrawing aliquots.

Procedure

Weigh a 20.0-g sample of moist sediment (SID) in a 150-ml

beaker. (The solids content of the sample should be known in advance or determined on a separate sample aliquot.) Acidify the sample with conc. sulfuric or conc. hydrochloric acid to pH 2.

Add 25 g $MgSO_4 \cdot H_2O$ to the acidified sediment sample. Stir to make a uniformly smooth paste that is spread on the beaker wall. Allow to stand 15 to 30 min until solidified. Remove the solids and grind in a porcelain mortar. The use of a desiccated, uniformly ground sample improves the efficiency of the extraction process.

Add the ground sample to a paper extraction thimble. The beaker and mortar should be wiped with a small piece of filter paper that has been soaked in Freon. Add the filter paper to the paper thimble. Fill the thimble with glass wool or small glass beads. Extract the prepared sample with Freon in a Soxhlet apparatus at a rate of 20 cycles/hr for 4 hr. If the final extract is turbid, filter the sample through grease-free cotton into a clean flask. Rinse the initial sample container and the cotton with Freon and add the washing to the filtered sample. Determine the oil and grease concentration of the extract by either infrared spectrophotometry (a) or gravimetry (b). The infrared method would be preferred because it is generally more precise; particularly at low oil and grease concentrations.

- a. Infrared spectrophotometry.^{1,2} Quantitatively transfer the sediment extract to a convenient size volumetric flask and dilute to volume with Freon.

Prepare calibration standards using either the known oil reference standard or the unknown oil reference standard. (A known oil is defined as the only grease and/or oil component in the samples being analyzed. An unknown oil is defined as the grease and/or oil component(s) in the sample being analyzed for which standard preparations are not available.) Transfer required amounts of the appropriate reference material into 100-ml volumetric flasks using microliter pipettes. Dilute to volume with Freon.

The most appropriate pathlength for the quartz cells to be used in the spectrophotometric determination is determined by the expected sample concentration. The following information is presented as a guide for selecting cell length:

<u>Pathlength, cm</u>	<u>Expected Range, mg</u>
1	4 - 40
5	0.5 - 8
10	0.1 - 4

Based on observed ranges of oil and grease in sediments, it may be necessary to dilute the sample extracts to the working ranges indicated above.

Scan the standards and samples from 3200 to 2700 cm^{-1} using a recording infrared spectrophotometer. Freon should be used in the reference beam of a dual beam instrument or to zero a single beam instrument. The absorbance of the 2930- cm^{-1} peak should be used to construct a standard curve.

- b. Gravimetry.¹ The gravimetric determination of oil and grease does not require dilution of the samples. However, the procedure is considered less precise than the infrared determination because the method is subject to positive sulfur interference and greater uncertainty at low oil and grease concentrations.

To implement the method, quantitatively transfer the sediment extract to a tared distilling flask. Rinse the extract container with Freon and add to the distilling flask. Distill the Freon from the extraction flasks using a water bath at 70°C. After the solvent has been evaporated, place the flask on a warm steam bath for 15 min and draw air through the flask by means of an applied vacuum for the final 1 min. Cool in a desiccator for 30 min and weigh. The gain in weight is due to oil and grease if the solvent is free of residue.

Calculations

Select the appropriate method and calculate the oil and grease concentration based on the method of quantification that was used.

- a. Infrared spectrophotometry. When colorimetry is used, prepare a standard curve by plotting measured absorbance vs. oil and grease concentration of the standards. Compare the absorbance of the Freon extract to the standard curve to determine the oil and grease concentration.

Calculate the oil and grease concentration O + G of the original water sample as follows:

$$O + G \text{ mg/kg (wet weight)} = \frac{(X)(V)(1000)}{F}$$

$$O + G \text{ mg/kg (dry weight)} = \frac{(X)(V)(1000)}{(g)(\% S)}$$

where

X = concentration of oil and grease in the Freon extract, mg/l

V = volume of Freon extract, l

g = wet weight of sediment extracted, g

% S = percent solids in the sediment sample (expressed as a decimal fraction)

- b. Gravimetry. When the amount of oil and grease is determined by weighing the material extracted, the oil and grease concentration of the sediment sample is calculated as follows:

$$O + G \text{ mg/kg (wet weight)} = \frac{(A - B - C)(1000)}{(g)}$$

$$O + G \text{ mg/kg (dry weight)} = \frac{(A - B - C)(1000)}{(g)(\% S)}$$

where

A = weight of tared flask and oil and grease residue, mg

B = weight of tared flask, mg

C = calculated residue based on Freon flask, mg

g = wet weight of sediment extracted, g

% S = percent solids in the sediment sample (expressed as a decimal fraction)

AD-A103 788

STATE UNIV OF NEW YORK COLL AT BUFFALO GREAT LAKES LAB F/G 13/2 -
PROCEDURES FOR HANDLING AND CHEMICAL ANALYSIS OF SEDIMENT AND W--ETC(11)
MAY 81 R H PLUMB EPA-44-05-5720-10

UNCLASSIFIED

EPA/CE-R1-1

NL

5 of 6
AL
2008

A large rectangular area consisting of a grid of approximately 15 columns and 15 rows. The majority of the cells in this grid are filled with solid black, obscuring any text or data that might have been present. Only the grid lines are visible.

References

1. American Public Health Association. Standard Methods for the Examination of Water and Wastewater Including Bottom Sediments and Sludges. 14th Edition. APHA; New York, New York. 1193 p. (1976).
2. Environmental Protection Agency. "Manual of Methods for Chemical Analysis of Water and Wastes." Methods Development and Quality Assurance Research Laboratory, National Environmental Research Center; Cincinnati, Ohio. 298 p. (1974).
3. Disalvo, L., Guard, H., Hirsch, N., and Ng, J. "Assessment and Significance of Sediment-Associated Oil and Grease in Aquatic Environments." Naval Biosciences Laboratory, Naval Supply Center; Oakland, California. Technical Report D-77-26; U. S. Army Engineer Waterways Experiment Station, CE; Vicksburg, Mississippi. 145 p. (1977).

CHLORINATED HYDROCARBONS

Chlorinated hydrocarbons are man-made compounds generally used as insecticides or pesticides. A second group of compounds, polychlorinated biphenyls (PCB's), have also received extensive usage as plasticizers. Because of the hydrophobic nature of these compounds, water concentrations are usually very low and sediment concentrations are higher due to the combined processes of sorption and sedimentation.

Chlorinated hydrocarbon residues must be concentrated prior to analysis. The methods available for sample concentration are solvent extraction and carbon absorption.^{1*} However, because of a lack of control on the sorption-desorption processes, solvent extraction should be considered the method of choice. While 100 percent recovery would be ideal, any solvent system that produces greater than 80 percent recovery is considered acceptable.² The solvent extraction procedure will concentrate chlorinated hydrocarbons for analysis but will also concentrate interfering substances such as pesticide degradation products, pesticide metabolites, lipid material, and, in the case of sediments, elemental sulfur.³ Therefore, the extracts must be cleaned up prior to quantification.

Sample Handling and Storage

Samples for chlorinated hydrocarbon analysis should be stored in glass bottles.² To prevent sample contamination on the part of the sample bottle caps or the cap liner, samples should be sealed with either Teflon or acetone/hexane washed heavy-duty aluminum foil.

Storage is less critical with chlorinated hydrocarbons than with other organic compounds such as organophosphate and carbamates due to the increased stability of chlorinated hydrocarbons. Consequently, sediment samples may be stored in a field moist, air-dried, or frozen condition (Figure 3-40). An increase in the chlorinated hydrocarbon residue stability can be achieved by extracting the samples as soon as possible to minimize the effects of microbial degradation.

* References can be found on page 3-318.

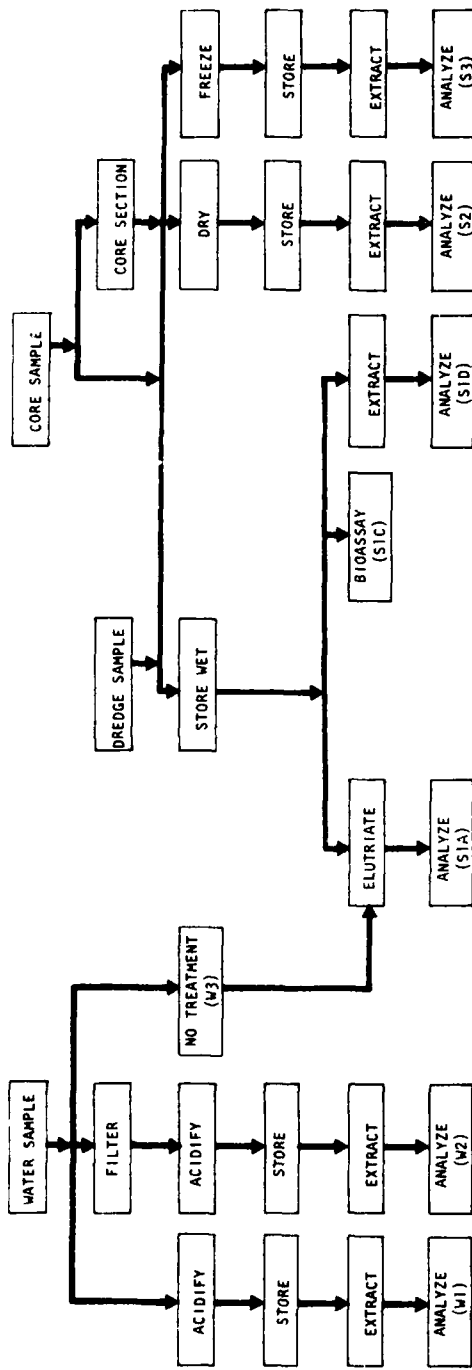

SAMPLE DESIGNATION	W1		W2		W3		S1A		S1C		S1D		S2		S3	
	Total Water Conc.	Soluble Water Conc.	Filter	Used in Elutriate	Mobile Conc.	Bioavail- ability	Total Sediment Conc.	Total Sediment Conc.	Total Sediment Conc.	Total Sediment Conc.	Total Sediment Conc.	Total Sediment Conc.	Total Sediment Conc.	Total Sediment Conc.	Total Sediment Conc.	Total Sediment Conc.
PURPOSE	G	G	None	None	G	G	G	G	G	G	G	G	G	G	G	G
CONTAINER																
SAMPLE TREATMENT	None	Filter	None	None	None	None	None	None	None	None	Air Dry	Freeze				
PRESERVATIVE	4°C	4°C		None	4°C (Minimize Air Contact. Keep Field Moist.)	4°C	4°C	4°C	4°C	4°C	None	None	None	None	None	None
STORAGE TIME	<1 W	<1 W		<1 W	<1 W	<1 W	<1 W	<1 W	<1 W	<1 W	-	-	-	-	-	-
DIGESTION SOLUTION	----- Hexane, ethyl ether in hexane and chloroform ----- ----- Acetonitrile or acetone/hexane. -----															
SAMPLE VOLUME OR WEIGHT	1-2 liter	1-2 liter	-	-	1-2 liter	Variable	10-25 g	10-25 g	10-25 g	10-25 g	10-25 g	10-25 g	10-25 g	10-25 g	10-25 g	10-25 g

Figure 3-40. Handling and storage of samples for chlorinated hydrocarbon analysis

The use of plastic equipment and/or utensils during sample collection, storage, and handling is to be avoided.

Procedures for Water Samples (W1, W2, S1A)

Method 1: Benzene Extraction⁴

Apparatus

All glassware must be washed with heavy-duty soap and hot water and rinsed well. Glassware should be rinsed with analytical grade acetone, pesticide grade ethyl acetate, and finally with sufficient quantities of pesticide-grade hexane. After rinsing, heat the glassware in an oven at 300° to 400°C overnight. (Heating alone will not remove all the organic constituents.) Rinse the glassware again with hexane prior to use. For heavily contaminated glassware, such as those used to store concentrated pesticide standards, soaking in ethyl acetate may be required after the rinsing procedure. The use of this glassware during sample analysis is to be avoided if at all possible

Gas chromatograph: Varian 2800 or a Microtek 220, equipped with electron capture detector and recorder

Gas chromatograph columns: the following columns have been used for the separation of chlorinated hydrocarbons:

- a. 4 percent SE-30 and 6 percent QF-1 on 60-80 (or 100-120) mesh size Chromosorb W, acid washed, DMCS treated
- b. 6 percent QF-1 and 4 percent DC-11 on 100-120 mesh size on Chromosorb W, acid washed and DMCS treated
- c. 11 percent OV-17/QF-1 (commercially prepared by Applied Science Lab, Inc.) on 100-120 Gas-Chrom Q
- d. 4 percent OV-101/6 percent OV-210 on Chromosorb W, acid washed and HDMS treated, 80-100 mesh size

Disposable pipets

Graduated centrifuge tubes, 15 ml with glass stoppers

Volumetric flasks, 5, 10, and 100 ml

Round-bottomed flasks, 200, 300, and 500 ml, with 24/40 ground-glass joint

Rotary evaporator

Chromatographic columns, 20 mm by 400 cm, with Teflon stopcocks

Micro-syringes, Hamilton, 10 µl for injections, and other sizes such as 5, 50, 100, and 250 µl for preparation of standard solutions

400°C oven

Oven for storing Florisil at 130°C

Muffle furnace capable of reaching 900°C

Filter funnel, with 10 x 4 cm reservoir, porosity B sintered glass disc
(available from Ace Glass, Inc.)

Reagents

All solvents must be of pesticide grade and checked before use. All chemicals must be of highest purity and, if applicable, should be preheated to eliminate artifacts or interferences.

Acetonitrile.

Acetone.

Hexane or petroleum ether.

Benzene.

Iso-Octane or toluene.

Chloroform.

Alumina, pretreated.

Anhydrous sodium sulfate, pretreated.

Florisil, 60-100 mesh, calcined at 650°C (factory treated) and kept at 130°C until use.

Pesticide standards and standard solutions.

Procedure

Sample pretreatment consists of three steps. Chlorinated hydrocarbons and PCB's are isolated and concentrated by solvent extraction. The extract is then subjected to successive cleanup on alumina and Florisil columns. Finally, the extract is analyzed using gas chromatography. At a minimum, the extract should be analyzed using two columns of different polarity.

Extraction

Add approximately 25 ml benzene to 1 l of water sample in the original sample bottle. Stir the mixture for 30 min with a magnetic stirrer so the vortex formed at the surface almost reaches the bottom of the bottle. (Wash the stirring bar in acetone and hexane prior to use.) Quantitatively transfer the mixture to a 1-l separatory funnel. Rinse the sample bottle with two 30-ml benzene washes and add to the separatory funnel.

Vigorously shake contents of separatory funnel and allow organic layer to separate. If an emulsion forms, add one of the following: saturated sodium sulfate solution, methanol, isopropanol, or

2-octanol and gently agitate.

NOTE 1: Added reagents should be checked to make sure that they do not contribute interfering peaks.

NOTE 2: Alcohol addition should be limited to 5 to 10 drops to avoid a large, interfering solvent peak.

Transfer the aqueous layer back to the empty sample bottle. Dry the organic layer by rapid suction through 50 g sodium sulfate in a filter funnel. Store the organic extract in a 300-ml round-bottomed flask.

Add 25 ml benzene to the aqueous phase in the sample bottle. Stir for 10 min and transfer to the separatory funnel. Rinse sample bottle with 20 ml benzene and add to separatory funnel. Transfer the aqueous layer to the sample bottle. Dry the organic layer as before and add to the first extract.

Repeat the extraction process a third time using a 30-ml portion of benzene.

To the combined organic extracts, add 1 ml iso-octane and concentrate on a rotary evaporator to approximately 3 ml. During the evaporation process, the water bath temperature should not exceed 40°C. When the extract has been concentrated to 10 to 12 ml, let the flask rotate in air away from the water bath until the final volume of approximately 3 ml has been achieved. This step is critical as severe loss of some pesticides may occur if the water bath is too warm or the extract is allowed to go to dryness.

Alumina cleanup

Transfer the concentrated extract to a 15-ml graduated centrifuge tube. Rinse with hexane and add to the centrifuge tube. Evaporate the extract, under a gentle stream of nitrogen, to a volume of approximately 1 ml.

Prepare a microcolumn for sample cleanup by plugging cleaned disposable pipets with a piece of precleaned glass wool. Add 2 in. of deactivated alumina, prepared by mixing neutral alumina with 5 percent of its weight of distilled water and tumbling for 2 hr before use. Top the column with 1/2 in. of anhydrous sodium sulfate.

Using a disposable pipet, quantitatively transfer the

extract onto the column and wash the centrifuge tube with 1 ml 25 percent benzene in hexane (1:3 benzene:hexane). As soon as the concentrated extract sinks down to the sodium sulfate layer, transfer the benzene/hexane washing to the column. Wash the tube with an additional 2 ml of 25 percent benzene and transfer to the column. After the solvent sinks into the sodium sulfate layer, elute the column with 25 percent benzene until 10 ml eluate is collected. Add 0.5 ml iso-octane to the eluate and evaporate to 0.5 ml in a 50°C water bath under a gentle stream of nitrogen gas.

If PCB's are known to be absent and/or only a limited number of chlorinated hydrocarbons are known to be present, this solution can be diluted to volume and analyzed by gas chromatography. If PCB's are present and/or a complex mixture of chlorinated hydrocarbons is present in the sample, the extract must be fractionated on a Florisil column prior to quantification.

Florisil cleanup

Fill a 20- by 400-mm chromatographic column with a coarse sintered disc near the bottom approximately three-fourths (3/4) full with hexane. Add 2 g pretreated sodium sulfate followed by 10 g of Florisil added in portions. Each portion should be 60-100 mesh, 650°C factory treated, stored at 130°C, and cooled in a desiccator before use. Tap the column gently while adding the Florisil to the column to prevent channeling in the column. Drain some hexane from the column to settle the Florisil. Add 3 g pretreated sodium sulfate to minimize disturbance of the Florisil layer.

Prewash the column with 50 ml benzene, followed by two successive additions of 75 ml hexane. Allow the column to drain and discard eluates.

Dilute the concentrated sample extract to approximately 2 ml with hexane. Quantitatively transfer the sample to the column. Allow the extract to sink just to the surface of the sodium sulfate layer. Wash the round-bottomed flask with 3 ml hexane and transfer the washing solution to the column. Let the extract run down as before. Rinse the flask with two additional 3-ml hexane portions and add each to the column.

Carefully add 100 ml hexane to the column without disturbing the Florisil layer.

Run the eluate into a 200-ml round-bottomed flask. Place sample on a roto-evaporator and concentrate to 10 to 12 ml in a 40°C water bath. Remove from the water bath and continue to rotate the flask in the air until the volume is reduced to 3 ml.

NOTE 3: Do not overheat sample or take to dryness.

Quantitatively transfer the concentrate to a 15-ml graduated centrifuge tube. Wash the flask with 2 to 3 ml petroleum ether and add to the centrifuge tube. Repeat the rinsing procedure. Add 0.5 ml iso-octane (or toluene) and concentrate sample to 0.5 ml under a gentle stream of nitrogen. This fraction is ready for GC analysis. (See NOTE 4.)

Elute the same column with 100 ml 6 percent ethyl ether in petroleum ether (or 6 percent ethyl ether in hexane). Catch the eluate in a clean, 200-ml round-bottomed flask. Concentrate the eluate as above. This fraction is ready for GC analysis. (See NOTE 4.)

Elute the column a third time with 100 ml 15 percent ethyl ether in petroleum ether (or 15 percent ethyl ether in hexane). Catch eluate in a clean, round-bottomed flask and concentrate as before. This fraction is ready for GC analysis. (See NOTE 4.)

Repeat column extraction with 100 ml 50 percent ethyl ether in petroleum ether (or chloroform) and proceed as above. The final extract is ready for GC analysis. (See NOTE 4.)

NOTE 4: The four fractions can be analyzed for the following chlorinated hydrocarbons:

Fraction 1 (hexane) - α -BHC, heptachlor, aldrin, p,p¹-DDE, and PCB's (Aroclor 1248, 1254, and 1260).

Fraction 2 (6 percent ethyl ether in hexane) - p,p¹-DDD, p,p¹-DDT, o,p¹-DDT, lindane, α -chlordane, transchlordane, methoxychlor, and heptachlor epoxide.

Fraction 3 (15 percent ethyl ether in hexane) - endrin, α -endosulfur, and dieldrin.

Fraction 4 (chloroform) - β -endosulfan.

Identification of chlorinated hydrocarbon pesticides and PCB's should be based on retention time on at least two different columns of different polarity (Table 3-20). Confirmation is based on the preparation and identification of chemical derivatives, thin-layer chromatography, and/or mass spectroscopy.

Calculations

A standard calibration curve should be prepared daily. Pesticide concentrations are determined by comparing the sample response to the standard curve (provided the recorder response is less than 70 percent of full scale and the peak height [or area] is close to that of the standard) as follows:

$$\text{g chlorinated hydrocarbon/l} = \frac{(A)(B)(C)}{(D)(E)(F)} \times 10^{-3}$$

where

- A = peak height (or area) produced by sample
- B = picograms standard injected into GC
- C = final volume of sample concentrate, ml
- D = peak height (or area) produced by B
- E = volume of water initially extracted, l
- F = volume of sample extract injected to produce A, μl

Remarks

Factory-calcined Florisil (at 650°C) varies in activity from batch to batch. It is necessary to standardize a new batch when it is received; the activity should be checked periodically to ensure it does not change upon storage. A large batch of Florisil should be subdivided quickly into smaller portions (a portion is taken out and then subdivided) in a dehumidified room and each portion stored in a tightly capped brown bottle in a desiccator. Enough supply of Florisil for a week or so is transferred in a glass-stoppered bottle and kept at 130°C until used.

NOTE: Do not unnecessarily expose Florisil to the atmosphere.

Standardization of Florisil: use a mixed nanogram solution containing 10 ng/ μl each of lindane, heptachlor, aldrin, heptachlor epoxide, p,p¹-DDE, 20 ng/ μl of p,p¹-DDD and 40 ng/ μl of p,p¹-DDT. Prepare a Florisil column containing 10 g Florisil as described earlier.

Table 3-20

Retention Times of Various Organochlorine Pesticides Relative to Aldrin

Pesticide	Relative Retention Time Under Given Conditions*		Liquid Phase: 5% OV-210 ^{††}
	Liquid Phase: 1.5% OV-17 + +1.95% QF-1 [†]		
αBHC	0.54		0.64
PCNB	0.68		0.85
Lindane	0.69		0.81
Dichloran	0.77		1.29
Heptachlor	0.82		0.87
Aldrin	1.00		1.00
Heptachlor epoxide	1.54		1.93
Endosulfan I	1.95		2.48
p,p'-DDE	2.23		2.0
Dieldrin	2.40		3.00
Captan	2.59		4.09
Endrin	2.93		3.56
o,p'-DDT	3.16		2.70
p,p'-DDD	3.48		3.75
Endosulfan II	3.59		4.59
p,p'-DDT	4.18		4.07
Mirex	6.1		3.78
Methoxychlor	7.6		6.5
Aldrin (min absolute)	3.5		2.6

* All columns glass, 180 cm by 4 mm I.D., solid support Gas-Chrom Q (100/120 mesh).

[†] Column temperature, 200°C; argon/methane carrier flow, 60 ml/min.

^{††} Column temperature, 180°C; argon/methane carrier flow, 70 ml/min.

Dilute 50 µl of the mixed standard to approximately 1 ml in a tube and transfer the solution to the column. Follow Florisil Elution Procedure to obtain three fractions. Concentrate each fraction to 10 ml and examine by GLC.

The elution rate should be adjusted to 5 to 6 ml/min. The first fraction (hexane or petroleum ether) should contain: heptachlor, aldrin, and DDE. The second fraction should contain: lindane, heptachlor epoxide, DDD, and DDT; and the last fraction (15 percent ether in hexane or petroleum ether) should contain dieldrin. If the separation is not clear cut (i.e. overlapping of the fractions), Florisil can be increased or decreased first by 2 g, then narrowed down to 1 g. Alternatively, volume of elution solvent can also be adjusted to obtain complete fractionation; however, this approach is limited only to minor overlapping of different fractions.

If separation of DDE and PCB's is desirable, the charcoal column developed by Berg et al.⁵ can be used.

Method 2: Methylene Chloride/Hexane Extraction²

Apparatus

Gas chromatograph fitted with electron capture, flame photometric, and electrolytic conductivity detectors

Gas chromatograph columns, 22 by 300 mm, with Teflon stopcocks, without frits. Use one of the following column packing mixtures:

- a. 1.5 percent OV-17/1.95 percent OV-210 - Liquid phases premixed and coated on silanized support, 80-100 mesh size

Instrument operating conditions with this column are: operating temperature, 200°C; detector temperature, 205°C; carrier flow, 50-70 ml/min

- b. 4 percent SE-30/6 percent OV-210 - Liquid phases premixed and coated on silanized support, 80-100 mesh size

Instrument operating conditions with this column are: operating temperature, 200°C; detector temperature, 205°C; carrier flow, 70-90 ml/min

- c. 5 percent OV-210 - coated on silanized support, 100-120 mesh

Instrument operating conditions with this column are: operating temperature, 200°C; detector temperature, 205°C; carrier flow, 45-60 ml/min

Water bath capable of maintaining 95° to 100° C

Separatory funnels, 2 l, with Teflon stopcocks

Filter tubes, 150 by 24 mm, Corning 9480 or the equivalent

Kuderna-Danish concentrator fitted with graduated evaporative concentrator tube. These are available from the Kontes Glass Company, each component bearing the following stock numbers:

- a. Flask, 500 ml, Stock # K-570001
- b. Snyder column, 3-ball, Stock # K-503000
- c. Steel springs, 1/2 in., Stock # K-662750
- d. Concentrator tubes, 10 ml, Size 1025, Stock # K-570050

Modified micro-Snyder columns, 19/22, Kontes Stock # K-569251

Glass beads, 3 mm, plain, Fisher Stock # 11-312 or equivalent

Modified micro-Snyder column, 19/22 T-joint, Kontes Stock # 569251

Pipet, vol., 4 ml

Reagents

Hexane, pesticide quality, distilled in glass.

Isooctane, pesticide quality.

Diethyl ether, AR grade, peroxide free. The ether must contain 2 percent (v/v) absolute ethanol. Most of the AR grade ethyl ether contains 2 percent ethanol, added as a stabilizer; it is, therefore, unnecessary to add ethanol unless it is found necessary to remove peroxides.

NOTE: To determine the absence of peroxides, test in accordance with the method outlined elsewhere.

Petroleum ether, pesticide quality, redistilled in glass; b.p. 30° to 60° C.

Methylene chloride, pesticide quality.

Methylene chloride/hexane, 15 percent v/v.

Eluting mixture, 6 percent (6 + 94): 60 ml of diethyl ether is diluted to 1000 ml with petroleum ether and approximately 15 g of anhydrous Na₂SO₄ is added to ensure freedom from moisture.

Eluting mixture, 15 percent (15 + 85): 150 ml of diethyl ether is diluted to 1000 ml with petroleum ether and approximately 15 g of anhydrous Na₂SO₄ is added.

NOTE: None of the eluting mixtures should be held longer than 24 hr after mixing.

Anhydrous sodium sulfate, reagent grade, granular, Mallinkrodt Stock # 8024 or equivalent.

NOTE: The purity of this material should be tested as outlined elsewhere (Section 5, A, (1), P3)² except that 15 percent methylene chloride/hexane should be substituted for petroleum ether.

Florisil, 60/100 mesh, PR grade.

Procedure

It is assumed that final thin layer chromatography and electrolytic conductivity confirmation may be applied to supplement the information obtained by electron capture detection. For this reason, a larger sample is used than would be necessary for electron capture detection alone. Dilution of an aliquot of the final extract for analysis using gas chromatography with electron capture detection requires less time than the extraction of a second sample for identity confirmation.

Transfer 2 l of sample (or a lesser volume, if indicated) to a 4-l separatory funnel and add 120 ml of 15 percent methylene chloride/hexane (MC/hexane).

NOTES: If, on the basis of prior analysis of a given waterway, the residue levels may be expected to run high, a sample of 500 ml or 1 l may be indicated. In this event, the size of the separatory funnel should be 2 l and the extraction solvent volumes given as 120 ml should be reduced to 100 ml.

A 500-ml graduated cylinder is a suitable measuring device for the initial sample. Any measuring discrepancy up to 5.0 ml would result in an error no greater than 1.0 percent.

Stopper funnel and shake vigorously for 2 min. Allow layers to separate and draw off aqueous layer into a second 2-l separatory funnel.

Add another 120 ml of 15 percent MC/hexane to the aqueous phase in separatory funnel #2, stopper, and shake vigorously for another 2 min.

Prepare a 2-in. column of anhydrous, granular Na_2SO_4 in a 150- by 24-mm filter tube with a small wad of preextracted glass wool at the bottom. Position this over a 500-ml K-D flask to which is attached a 10-ml concentrator tube with one 3-mm glass bead in the bottom.

Filter the MC/hexane extract in the separatory funnel #1 through the Na_2SO_4 column into the flask.

Draw off the aqueous layer in separatory funnel #2 into empty separatory funnel #1.

Add 120 ml of straight hexane to the aqueous solution in separatory funnel #1, stopper, and shake again for 2 min. Draw off and discard the aqueous layer.

Filter the solvent extracts in both separatory funnels through the Na_2SO_4 into the flask, rinsing down filter tube with three 10-ml portions of hexane.

Attach a 3-ball Snyder column to the K-D flask, place assembly in a boiling water bath, and concentrate extract to approximately 5 ml.

Remove K-D assembly from bath, cool, and rinse T-joint between tube and flask with a small volume of hexane; also rinse down walls of tube. Rinse should be delivered with 2 ml Mohr pipet and should not exceed 3 ml.

Place tube under a slow nitrogen stream at ambient temperature and reduce extract volume to approximately 0.5 ml. Using a disposable pipet, carefully add hexane to adjust volume to exactly 1.0 ml in the tube tip. Then, with a 4-ml vol. pipet, add 4 ml of hexane. Do not rely on the accuracy of the tube graduation at the 5-ml mark.

Stopper concentrator tube and mix vigorously on a vortex mixer for 1 min. The sample is now ready for GLC analysis.

It should be possible to make some tentative compound identifications upon computation of relative retention times (RRT) of peaks in the preliminary chromatograms via electron capture. Full reliance should not be placed on the chromatographic data obtained from one column. An alternate column of completely different compound elution characteristics should be used to (a) confirm a number of compounds tentatively identified on the first column and (b) isolate and tentatively identify any compound pairs which may have eluted as single peaks on the first column.

If the initial chromatogram indicates the presence of a sufficient amount of interfering materials, it may prove necessary to conduct a Florisil cleanup on the extract. Based on general experience, this is rarely necessary on most surface water samples. If it should prove necessary, process the cleanup as discussed on the next page.

Extract cleanup procedure

Prepare a chromatographic column containing $\frac{1}{4}$ in. (after settling) of activated Florisil topped with 0.5 in. of anhydrous granular Na_2SO_4 . A small wad of glass wool, preextracted with petroleum ether, is placed at the bottom of the column to retain the Florisil.

NOTES: If the oven is of sufficient size, the columns may be prepacked and stored in the oven, withdrawing columns a few minutes before use.

The amount of Florisil needed for proper elution should be determined for each lot of Florisil.

Place a 500-ml Erlenmeyer flask under the column and prewet the packing with petroleum ether (40 to 50 ml, or a sufficient volume to completely cover the Na_2SO_4 layer).

NOTE: From this point and through the elution process, the solvent level should never be allowed to go below the top of the Na_2SO_4 layer. If air is introduced, channeling may occur, resulting in an inefficient column separation.

Using a 5-ml Mohr or a long disposable pipet, immediately transfer the extract (approximately 5 ml) from the evaporator tube onto the column and permit it to percolate through.

Rinse tube with two successive 5-ml portions of petroleum ether, carefully transferring each portion to the column with the pipet.

NOTE: Use of the Mohr or disposable pipet to deliver the extract directly onto the column precludes the need to rinse down the sides of the column.

Prepare two Kuderna-Danish evaporative assemblies complete with 10-ml graduated evaporative concentrator tubes. Place one glass bead in each concentrator tube.

Replace the 500-ml Erlenmeyer flask under each column with a 500-ml Kuderna-Danish assembly and commence elution with 200 ml of 6 percent diethyl ether in petroleum ether (Fraction 1). The elution rate should be 5 ml per min. When the last of the eluting solvent reaches the top of the Na_2SO_4 layer, place a second 500-ml Kuderna-Danish assembly under the column and continue elution with 200 ml of 15 percent diethyl ether in petroleum ether (Fraction 2).

To the second fraction only, add 1.0 ml of hexane containing

200 nanograms of aldrin, place both Kuderna-Danish evaporator assemblies in a water bath, and concentrate extract until approximately 5 ml remain in the tube.

Remove assemblies from bath and cool to ambient temperature.

Disconnect collection tube from Kuderna-Danish flask and carefully rinse joint with a little hexane.

Attach modified micro-Snyder column to collection tubes, place tubes back in water bath, and concentrate extracts to 1 ml. If preferred, this may be done at room temperature under a stream of nitrogen.

Remove from bath and cool to ambient temperature. Disconnect tubes and rinse joints with a little hexane.

NOTE: The extent of dilution or concentration of the extract at this point is dependent on the pesticide concentration in the substrate being analyzed and the sensitivity and linear range of the electron capture detector being used in the analysis.

Should it prove necessary to conduct further cleanup on the 15 percent fraction, transfer 10 g MgO-Celite mixture to a chromatographic column using vacuum to pack. Prewash with approximately 40 ml petroleum ether, discard prewash, and place a Kuderna-Danish receiver under column. Transfer concentrated Florisil eluate to column using small portions of petroleum ether. Force sample and washings into the MgO-Celite mixture by slight air pressure and elute column with 100 ml petroleum ether. Concentrate to a suitable volume and proceed with gas liquid chromatography.

NOTE: Standard recoveries should be made through column to ensure quantitative recoveries.

Inject 5 μ l of each fraction into the gas chromatograph for the purpose of determining the final dilution. If all peaks are on scale and quantifiable, it will not be necessary to proceed with any further adjustment in concentration.

If off-scale peaks are obtained in either fraction, it will be necessary to dilute volumetrically with hexane to obtain a concentration that will permit quantification of those peaks from a 5- to 10- μ l injection.

If the electron capture data indicate the probable presence

of one or more chlorinated pesticide compounds, the chromatographer would be well advised to conduct confirmation via electrolytic conductivity detection in the reductive mode even though positive identifications were made on two columns via electron capture. This extra step provides needed validation, particularly when compounds are tentatively identified which appear to be out of place in light of known supplemental data concerning the waterway sampled.

It is improbable that parent compounds in the organophosphorus class will be detected in an average water sample. Compound degradation is rather rapid in the aqueous medium. However, if the waterway receives heavy runoff from nearby agricultural land undergoing current spray programs, the presence of these residuals is possible.

Calculations

A standard calibration curve should be prepared daily. Pesticide concentrations are determined by comparing the sample response to the standard curve (provided the recorder response is less than 70 percent of full scale and the peak height [or area] is close to that of the standard) as follows:

$$\mu\text{g chlorinated hydrocarbon}/\ell = \frac{(A)(B)(C)}{(D)(E)(F)} \times 10^{-3}$$

where

- A = peak height (or area) produced by sample
- B = amount of standard injected into GC, picograms
- C = final volume of sample concentrate, ml
- D = peak height (or area) produced by standard B
- E = volume of water initially extracted, ℓ
- F = volume of sample extract injected to produce A, μl

Remarks

This method will not detect the acid form of herbicides such as 2,4-D or 2,4,5-T, but should be suitable for certain of the esters of these compounds which are used commercially. However, as these compounds are only about one tenth (1/10) as responsive to electron capture as a number of the common chlorinated pesticides, it appears somewhat remote that they would be detected in an average water sample by this procedure.

In a laboratory study conducted on river water in the Water

Quality Laboratory of the Environmental Protection Agency in Cincinnati,² the degradation pattern shown in Table 3-21 was reported on a 20-gal sample of water held in the laboratory under sunlight and fluorescent light. These data are presented for supplemental information.

The two fractions from the Florisil column should never be combined for examination by gas liquid chromatography. By so doing, a valuable identification tool is voided.

Meticulous cleaning of glassware is absolutely essential for success with this procedure. All reagents and solvents must be pretested to ensure that they are free of contamination by electron capturing materials at the highest extract concentration levels. Reagent blanks should be run with each set of samples.

The method, as described, is known to be capable of producing recoveries of most of the chlorinated pesticides of from 85 to 100 percent. Each laboratory should conduct its own recovery studies to make certain of its capability to achieve this recovery range. A clue may be obtained from the recovery of the aldrin spike. The recovery of this compound should not be less than 70 percent.

For the removal of peroxides from the ethyl ether, place an appropriate volume in a separatory funnel and wash it twice with portions of water equal to about one half the volume of ether. The washed ether is shaken with 50 to 100 ml of saturated NaCl solution and all of the aqueous layer is discarded. The ether is then transferred to a flask containing a large excess of anhydrous sodium sulfate and shaken vigorously on a mechanical shaker for 15 min. This treatment should not be attempted on ether-containing ethanol, as the amount of ethanol that would remain is indeterminate.

If the presence of malathion is suspected, it is necessary to pass 200 ml of 50 percent diethyl ether in petroleum ether through the Florisil column into a third K-D evaporator assembly, concentrating the eluate as described for the 6 percent and 15 percent eluates.

Table 3-21
Persistence of Chlorinated Hydrocarbon Pesticides in
River Water in Terms of Percentage Recovery²

Compound	Original Compound Found*, %				
	0-time	1 wk	2 wk	4 wk	8 wk
Organochlorine Compounds					
BHC	100	100	100	100	100
Heptachlor	100	25	0	0	0
Aldrin	100	100	80	40	40
Heptachlor epoxide	100	100	100	100	100
Telodrin	100	25	10	0	0
Endosulfan	100	30	5	0	0
Dieldrin	100	100	100	100	100
DDE	100	100	100	100	100
EDT	100	100	100	100	100
DDD	100	100	100	100	100
Chlordane (tech.)	100	90	85	85	85
Endrin	100	100	100	100	100
Organophosphorus Compounds					
Parathion	100	50	30	< 5	0
Methyl parathion	80	25	10	0	0
Malathion	100	25	10	0	0
Ethion	100	90	75	50	50
Trithion	90	25	10	0	0
Fenthion	100	50	10	0	0
Dimethoate	100	100	85	75	50
Merphos	0	0	0	0	0
Merphos recov. as Def	100	50	30	10	< 5
Azodrin	100	100	100	100	100
Carbamate Compounds					
Sevin	90	5	0	0	0
Zectran	100	15	0	0	0
Matacil	100	60	10	0	0
Mesuroi	90	0	0	0	0
Baygon	100	50	30	10	5
Monuron	80	40	30	20	0
Fenuron	80	60	20	0	0

* Pesticide concentrations were 10 µg/l. Recoveries were rounded off to the nearest 5 percent.

Procedures for Sediment Samples (S1D, S2, S3)²

Method 1: Acetone/Hexane Extraction

The examination of sediment from the bottom of a stream or lake provides information concerning the degree of contamination resulting from pesticides, particularly the organochlorine compounds which are not readily biodegradable. This information, combined with residue data obtained by analysis of the water and tissues from resident marine life, contributes to the development of an overall profile of the pesticidal contamination of a given body of water.

The sediment sample is partially dried and extracted by column elution with a mixture of 1:1 acetone/hexane. The extract is washed with water to remove the acetone and then the pesticides are extracted from the water with 15 percent CH_2Cl_2 in hexane. The extract is dehydrated, concentrated to a suitable volume, subjected to Florisil partitioning, desulfurized, if necessary, and analyzed by gas chromatography.

Apparatus

Gas chromatograph: Varian 2800, Microtek 220, or equivalent, equipped with an electron capture detector and recorder

Gas chromatograph columns, 22 by 300 mm, with Teflon stopcocks

Gas chromatograph column packing (See Methods 1 and 2 for the analysis of water.)

Pans, approximately 14 by 10 by 2-1/2 in.

Oven, drying

Muffle furnace

Desiccator

Crucibles, porcelain, squat form, Size 2

Omni or Sorvall mixer with chamber of approximately 400 ml

Separator funnels, 500 and 250 ml. with Teflon stopcocks

Filter tube, 180 by 25 mm

Kuderna-Danish concentrator fitted with graduated evaporative concentrator tube. Available from the Kontes Glass Company, each component bearing the following stock numbers:

a. Flask, 250 ml, Stock # K-570001

b. Snyder column, 3-ball, Stock # K-503000

c. Steel springs, 1/2 in., Stock # K-662750

d. Concentrator tubes, 10 ml, Size 1025, Stock # K-570050

Pyrex glass wool, preextracted with methylene chloride in a Soxhlet extractor

Hot water bath, temperature controllable at 80°C

Reagents

Sodium sulfate, anhydrous, Baker, prerinsed or Soxhlet extracted with methylene chloride.

n-Hexane, pesticide quality.

Acetone, pesticide quality.

Methylene chloride, pesticide quality.

Acetone-hexane, 1:1

Diethyl ether, pesticide quality, free of peroxides

Distilled water, suitable for pesticide residue analysis

Sodium sulfate solution, saturated

Methylene chloride-hexane, 15 percent v/v

Procedure

Decant and discard the water layer over the sediment. Mix the sediment to obtain as homogeneous a sample as possible and transfer to a pan to partially air dry for about 3 days at ambient temperatures.

NOTE: Drying time varies considerably depending on soil type and drying conditions. Sandy soil will sufficiently dry in 1 day whereas muck requires at least 3 days. The silt and muck sediment is sufficiently dry when the surface starts to split, but there should be no dry spots. Moisture content will be 50 to 80 percent at this point.

Weigh 50 g of the partially dried sample into a 400-ml Omni mixer chamber. Add 50 g of anhydrous sodium sulfate and mix well with a large spatula. Allow to stand with occasional stirring for approximately 1 hr.

NOTE: If the final calculations will be made on a dry basis, it is necessary at this point to initiate the test for percent total solids in the sample being extracted for pesticide evaluation. Immediately after weighing the 50-g sample for extraction, weigh approximately 5 g of the partially dried sediment into a tared crucible. Determine the percent solids by drying overnight at 103°C. Allow to cool in a desiccator for half an hour before weighing. Determine the percent volatile solids by placing the oven-dried sample into a muffle furnace and igniting at 550°C for 60 min. Allow to cool in a desiccator before weighing.

Attach the 400-ml chamber to an Omni or Sorvall mixer and blend for about 20 sec. The sample should be fairly free flowing at this point.

Carefully transfer the sample to a chromatographic column. Rinse the mixer chamber with small portions of hexane, adding the rinsings to the column.

Elute the column with 250 ml of 1:1 acetone-hexane at a flow rate of 3 to 5 ml/min into a 400-ml beaker.

Concentrate the sample extract to about 100 ml under a nitrogen stream and at a temperature no higher than 55°C. Transfer to a 500-ml separatory funnel containing 300 ml of distilled water and 25 ml of saturated sodium sulfate solution. Shake the separatory funnel for 2 min.

Drain the water layer into a clean beaker and the hexane layer into a clean, 250-ml separatory funnel.

Transfer the water layer back into the 500-ml separatory funnel and reextract with 20 ml of 15 percent methylene chloride in hexane, again shaking the separatory funnel for 2 min. Allow the layers to separate. Discard the water layer and combine the solvent extracts in the 250-ml separatory funnel.

Wash the combined solvent extract by shaking with 100 ml of distilled water for 30 sec. Discard the wash water and rewash the extract with an additional 10 ml of distilled water, again discarding the wash water.

Attach a 10-ml evaporator concentrator tube to a 250-ml Kuderna-Danish flask and place under a filter comprised of a small wad of glass wool and approximately 0.5 in. of anhydrous Na_2SO_4 in a filter tube.

Pass the solvent extract through the drying filter into the K-D flask, rinsing with three portions of approximately 5 ml each of hexane.

Attach Snyder column to top joint of a K-D flask, immerse tube in 80°C water bath, and concentrate extract to 5 ml.

Remove tube, rinsing joint with small volume of hexane. The sample is now ready for Florisil partitioning.

Prepare a Florisil chromatographic column containing 4 in. (after settling) of activated Florisil topped with 0.5 in. of anhydrous, granular Na_2SO_4 . A small wad of glass wool, preextracted with hexane, is placed at the bottom of the column to retain the Florisil.

NOTES: If the oven is of sufficient size, the columns may be prepacked and stored in the oven, withdrawing columns a few minutes before use.

The amount of Florisil needed for proper elution should be determined for each lot of Florisil.

Place a 500-ml Erlenmeyer flask under the column and prewet the packing with hexane (40 to 50 ml, or a sufficient volume to completely cover the Na_2SO_4 layer).

NOTE: From this point and through the elution process, the solvent level should never be allowed to go below the top of the Na_2SO_4 layer. If air is introduced, channelling may occur, making for an inefficient column.

Assemble two more K-D apparatus but with 500-ml flasks and position the flask of one assembly under the Florisil column. However, at this point, use 25-ml graduated evaporator concentrator tubes instead of the 10-ml size for previous concentrations.

Using a 5-ml Mohr or a long disposable pipet, immediately transfer the extract from the evaporator tube onto the column and permit it to percolate through. Rinse tube with two successive 5-ml portions of hexane, carefully transferring each portion to the column with the pipet.

NOTE: Use of the Mohr or disposable pipet to deliver the extract directly onto the column precludes the need to rinse down sides of the column.

Commence elution with 200 ml of 6 percent diethyl ether in petroleum ether (Fraction 1). The elution rate should be approximately 5 ml per min. When the last of the eluting solvent reaches a point approximately 1/8 in. from the top of the Na_2SO_4 layer, place the second 500-ml Kuderna-Danish assembly under the column and continue elution with 200 ml of 15 percent diethyl ether in petroleum ether (Fraction 2). Place both Kuderna-Danish evaporator assemblies in a water bath and concentrate extract to approximately 20 ml.

NOTE: If there is reason to suspect the presence of malathion in the sample, have a third 500-ml K-D assembly ready. At the end of the 15 percent fraction elution, add 200 ml or 50 percent diethyl ether in petroleum ether (Fraction 3), evaporating the eluate in the same manner.

Remove K-D assemblies from the bath, cool, and rinse the T-joint between the tube and flask with a little petroleum ether. Finally, dilute both extracts to exactly 25 ml and proceed with the GLC determinative step.

Inject 5 μ l of each fraction extract into the gas chromatograph (electron capture mode) primarily to determine whether the extracts will require further adjustment by dilution or concentration.

When appropriate dilution adjustments have been made in the extracts and the column oven is set at the required temperature, the relative retention values of the peaks on the chromatograms should be calculated. When these values are compared with the values in Table 3-20 for the appropriate column, the operator should be able to make tentative compound identifications. Microcoulometry and/or TLC may be required for positive confirmation of some of the suspect chlorinated compounds, whereas flame photometric detectors (FPD) may be utilized for the organophosphate suspects.

An analytical problem that must be considered when sediment samples are analyzed for chlorinated hydrocarbon pesticides is sulfur interference. Elemental sulfur is encountered in most sediment samples, marine algae, and some industrial wastes. The solubility of sulfur in various solvents is very similar to the organochlorine and organophosphate pesticides; therefore, the sulfur interference follows along with the pesticides through the normal extraction and cleanup techniques. The sulfur will be quite evident in gas chromatograms obtained from electron capture detectors, flame photometric detectors operated in the sulfur or phosphorus mode, and Coulson electrolytic conductivity detectors. If the gas chromatograph is operated at the normal conditions for pesticide analysis, the sulfur interference can completely mask the region from the solvent peak through aldrin.

This technique eliminates sulfur by the formation of

copper sulfide on the surface of the copper. There are two critical steps that must be followed to remove all the sulfur: (a) the copper must be highly reactive--therefore, all oxides must be removed so that the copper has a shiny, bright appearance; and (b) the sample extract must be vigorously agitated with the reactive copper for at least 1 min.

It will probably be necessary to treat both the 6 and 15 percent Florisil eluates with copper if sulfur crystallizes out upon concentration of the 6 percent eluate.

Certain pesticides will also be degraded by this technique, such as the organophosphates, chlorobenzilate, and heptachlor. However, these pesticides are not likely to be found in routine sediment samples because they are readily degraded in the aquatic environment.

If the presence of sulfur is indicated by an exploratory injection from the final extract concentrate (presumably 5 ml) into the gas chromatograph, proceed with removal as follows:

- a. Under a nitrogen stream at ambient temperature, concentrate the extract in the concentrator tube to exactly 1.0 ml.
- b. If the sulfur concentration is such that crystallization occurs, carefully transfer, by syringe, 500 μ l of the supernatant extract (or a lesser volume if the sulfur deposit is too heavy) into a glass-stoppered, 12-ml graduated conical centrifuge tube. Add 500 μ l of iso-octane. Add approximately 2 g of bright copper powder, stopper, and mix vigorously 1 min on a vortex genie mixer.

NOTE: The copper powder, as received from the supplier, must be treated for removal of surface oxides with 6 N HNO_3 . After about 30 sec of exposure, decant acid and rinse several times with distilled water and finally with acetone. Dry under a nitrogen stream.

- c. Carefully transfer 500 μ l of the supernatant-treated extract into a 10-ml graduated concentrator tube. An exploratory injection into the gas chromatograph at this point will provide information as to whether further quantitative dilution of the extract is required.

Calculations

The chlorinated hydrocarbon pesticide concentration of sediment can be calculated as:

$$\text{Chlorinated hydrocarbons } \mu\text{g/kg (wet weight)} = \frac{(A)(B)(C)}{(E)(F)(G)}$$

$$\text{Chlorinated hydrocarbons } \mu\text{g/kg (dry weight)} = \frac{(A)(B)(C)}{(E)(F)(G)(\% S)}$$

where

- A = nanograms standard injected into GC
- B = peak height (or area) produced by sample injection
- C = final volume of sample extract, ml
- E = peak height (or area) produced by standard injection A
- F = wet weight of sediment sample initially extracted, g
- G = volume of extract injected to produce B, ml
- % S = sediment percent solids as a decimal fraction

Method 2: Acetonitrile Extraction⁴

The sediment is extracted with acetonitrile and the chlorinated hydrocarbons are partitioned into petroleum ether. The ether extract is cleaned up on a Florisil column and separated into four fractions for subsequent GLC analysis. This method has been used to quantify the following chlorinated hydrocarbons and PCB's (with the value in parenthesis being the lowest level of detection in ppm):

Lindane	(0.001)
Heptachlor	(0.001)
Heptachlor Epoxide	(0.001)
Aldrin	(0.001)
Dieldrin	(0.001)
p,p'-DDD	(0.001)
p,p'-DDT	(0.001)
p,p'-DDE	(0.001)
o,p'-DDT	(0.001)
Endrin	(0.01)
p,p'-methoxychlor	(0.05)
α -endosulfan	(0.01)
β -endosulfan	(0.01)
cis-chlordane	(0.005)
trans-chlordane	(0.005)
Aroclor 1248	(0.100)
Aroclor 1254	(0.100)
Aroclor 1260	(0.100)

Apparatus

Gas chromatograph, Varian 2800, Microtek MT220 or equivalent, equipped with a flame photometric detector

GLC column packing materials (See Methods 1 and 2 for the analysis of water.)

GLC columns (See Methods 1 and 2 for the analysis of water.)

Disposable pipets

Magnetic stirrer and 5/8-in. Teflon-coated stirring bars

Graduated centrifuge tubes, 15 ml with glass stoppers

Kuderna-Danish (K-D) evaporator and associated glassware

Volumetric flasks

Hamilton micro-syringes, 10 μ l for GLC injection and 100 μ l for preparation of standard solutions

Graduated pipets, 2 and 10 ml

Heating plate

Vortex genie

Reagents

All solvents must be of pesticide grade. All chemicals must be of highest purity and, if applicable, should be pretreated to eliminate artifacts or interferences.

Acetonitrile.

Hexane or petroleum ether.

Benzene.

Diethyl ether containing 2 percent ethanol as preservative.

Florisil, 60-100 mesh, calcined at 650°C (factory treated) and kept at 130°C until used. (See discussions in the procedure for the analysis of chlorinated hydrocarbon pesticides and PCB's in water, Methods 1 and 2.)

Anhydrous sodium sulfate, pretreated.

Neutral alumina, Woelm, activity Grade I deactivated with 5 percent water. (See Method 1 for analysis of water.)

Pesticide standard and standard solutions.

Procedure

Quantification of chlorinated hydrocarbon pesticides is a three-step procedure consisting of extraction, extract cleanup, and identification.

Extraction. Transfer 10 g dry weight equivalent of sediment into the glass jar of a Waring blender with a Bakelite top.

(Do not use a rubber or plastic top.) Add 120 ml of acetonitrile and blend at medium-high speed for 15 min. Allow solid particles to settle somewhat. Pour the acetonitrile extract, which may contain some suspended particles, into an Allihn filter tube containing prewashed celite covering the sintered glass.

NOTE: If the residue in the Allihn filter tube becomes excessive, it should be scraped out with a spoon-type spatula and combined with that in the blender before the second blending and extraction.

To the residue in the blender, add another 120 ml of acetonitrile and 40 ml of distilled water and blend for 10 min. Filter as before.

Pour 60 ml of acetonitrile into the blender and blend the homogenate for 10 min. Transfer all the residue, if necessary, with 2 by 20 ml acetonitrile, into the Allihn tube and filter. Apply strong suction so that the residue in the tube contains little solvent.

Transfer, with petroleum ether rinsing, the combined acetonitrile extracts into a 1-l funnel and dilute with distilled water to adjust the aqueous content to 20 percent. Extract the resulting mixture with 150 ml and then twice with 75 ml petroleum ether.

Wash the combined petroleum ether extracts with approximately 200 ml distilled water. Discard water washing and pass the organic extract under suction or with air pressure, through an anhydrous sodium sulfate (10 to 15 g) column using a 500-ml round-bottomed flask as a receiver.

In a rotary evaporator, evaporate the contents in the 500-ml flask to 2 or 3 ml. (Do not let contents get dry and do not use a water bath temperature over 40°C for evaporation; otherwise, there will be possible loss of pesticides and PCB's. See evaporation precautions discussed in the procedure for water analysis.)

Cleanup. Transfer the concentrated petroleum ether extract with a clean disposable pipet onto a 30-g (for the exact amount to be determined, see procedure for water analysis) Florisil column with 0.5 in. of anhydrous sodium sulfate on the top of the

Florisil. Use a 300-ml round-bottomed flask as a receiver.

Allow the extract to sink down just to the sodium sulfate layer. Rinse the round-bottomed flask with 2 or 3 ml of petroleum ether and transfer the rinsing with the same disposable pipet onto the column. Let the rinsing solvent again sink down just to the sodium sulfate layer. Rinse the round-bottomed flask again with 2 or 3 ml of petroleum ether and transfer the rinsing onto the column.

Again rinse the round-bottomed flask, this time with 20 to 30 ml petroleum ether. Carefully pour the petroleum ether onto the column so that the sodium sulfate layer is not disturbed. Elute the column with a total of 200 ml (including the above rinsings) of petroleum ether.

Concentrate eluate with a rotary evaporator to 1 or 2 ml and transfer, with benzene rinsings, to a 10-ml volumetric flask. Make up to 10 ml with benzene for GLC examination (Fraction 1).

Change the receiver and elute column with 200 ml of 6 percent diethyl ether containing 2 percent ethanol. Concentrate eluate to 1 to 2 ml on a rotary evaporator. Transfer to a 10-ml volumetric flask. Rinse round-bottomed flask with benzene and add to volumetric flask. Dilute to volume with benzene. This fraction, Fraction 2, is now ready for GLC analysis.

With a third 300-ml round-bottomed flask as receiver, elute the column with 200 ml of 15 percent ether in petroleum ether. Concentrate to 10 to 20 ml with a rotary evaporator. Add 50 to 60 ml of benzene and concentrate to 1 to 2 ml. Make up to 10 ml with benzene in a volumetric flask (Fraction 3).

Elute the column with 200 ml chloroform or 200 ml 50 percent diethyl ether in petroleum ether. Collect the eluate in a round-bottomed flask and concentrate to 2 to 3 ml on a rotary evaporator. Add 50 to 60 ml benzene and reduce the volume to 2 to 3 ml. Add a second 50- to 60-ml portion of benzene and evaporate to 2 to 3 ml. Transfer the concentrate to a 10-ml volumetric flask. Rinse the round-bottomed flask with benzene and add the rinsing to the volumetric flask. This fraction is now ready for GLC analysis (Fraction 4).

The petroleum ether fraction (Fraction 1) contains PCB's, heptachlor, aldrin, p,p'-DDE, and α -BHC.

The 6 percent diethyl ether-petroleum ether fraction (Fraction 2) contains lindane, heptachlor epoxide, p,p'-DDT, p,p'-DDD, methoxychlor, o,p'-DDT, cis-chlordanes, and trans-chlordanes.

The 15 percent diethyl ether-petroleum fraction (Fraction 3) contains dieldrin, α -endosulfan, and endrin.

The last fraction (4) contains β -endosulfan.

Extracts may have to be cleaned up for sulfur interference. Follow procedures given in Sediment Method 1.

Identification. Examine the above four eluates by GLC. Further concentration and dilution may be necessary to produce on-scale GLC peaks. Procedures for confirmation of identity are the same as for water extracts.

Calculations

The concentration of chlorinated hydrocarbon pesticides in the sediment samples can be calculated as follows:

$$\text{Chlorinated hydrocarbons } \mu\text{g/kg (wet weight)} = \frac{(A)(B)(C)}{(E)(F)(H)}$$

$$\text{Chlorinated hydrocarbons } \mu\text{g/kg (dry weight)} = \frac{(A)(B)(C)}{(E)(F)(H)(\% S)}$$

where

A = weight of picograms of standard injected

B = peak height (or area) of sample

C = volume of sample extract, ml

E = peak height (or area) of standard

F = volume of sample extract required to produce B, μ l

H = wet weight of sediment initially extracted, g

% S = percent solids in sediment (expressed as a decimal fraction)

References

1. Brodtman, N. V., Jr. "Quantitation of Chlorinated Pesticides -- A Comparison of Methods." JAWWA:558-560 (1975).
2. Thompson, J. F. (Ed.) "Analysis of Pesticide Residues in Human and Environmental Samples." Environmental Protection Agency Pesticides and Toxic Substances Effects Laboratory; Research Triangle Park, North Carolina (1974).
3. Jensen, N., Benberg, L., and Reutergerdh, L. "Residue Analysis of Sediment and Sewage Sludge for Organochlorines in the Presence of Elemental Sulfur." Anal. Chem. 49:316-318 (1977).
4. Environment Canada. "Analytical Methods Manual." Inland Waters Directorate, Water Quality Branch; Ottawa, Ontario, Canada (1974).
5. Berg, O. W., Miosady, P. L., and Rees, G. A. V. Bull. Environ. Contam. Toxic, 7, 338.

ORGANOPHOSPHOROUS PESTICIDES

Organophosphates have received usage as pesticides because of their ability to inhibit the enzyme cholinesterase.^{1*} They are generally more acutely toxic than the compounds they were designed to replace, organochlorine hydrocarbons, but they also degrade more rapidly. The methods to quantitate organophosphorous compounds in environmental samples are based on organic extraction followed by gas chromatographic analysis² or an enzyme inhibition method.¹ Fenitrothion is determined by hexane extraction; dimethoate and phosphamidon are determined by chloroform extraction;² while 14 other organophosphorous can be determined by benzene extraction.² Because a phosphorous-specific detector is used, only minimal sample cleanup is generally required. The second method does not provide a quantitation of specific organophosphorous pesticides. Rather, the method provides an estimate of all compounds that can deactivate an enzyme. Thus, the results will include carbamates as well as organophosphate pesticides that are present in the sample.¹

Sample Handling and Storage

Samples should be collected and stored in clean glass containers. Because of the reactivity of organophosphates, samples should be extracted in the field whenever possible. At other times, samples should be maintained at 4°C and extracted as soon as possible. There is no known acceptable storage period for samples but extended residue stability is obtained by extraction. Also, several organophosphates (dimethoate, phosphamidon, fenitrothion) may degrade in the presence of sunlight.² Samples should only be exposed to subdued lighting to minimize this potential effect on sample integrity. Only wet sediment samples should be collected as suggested in Figure 3-41.

* References can be found on page 3-336.

Figure 3-41. Handling and storage of samples for organophosphate analysis

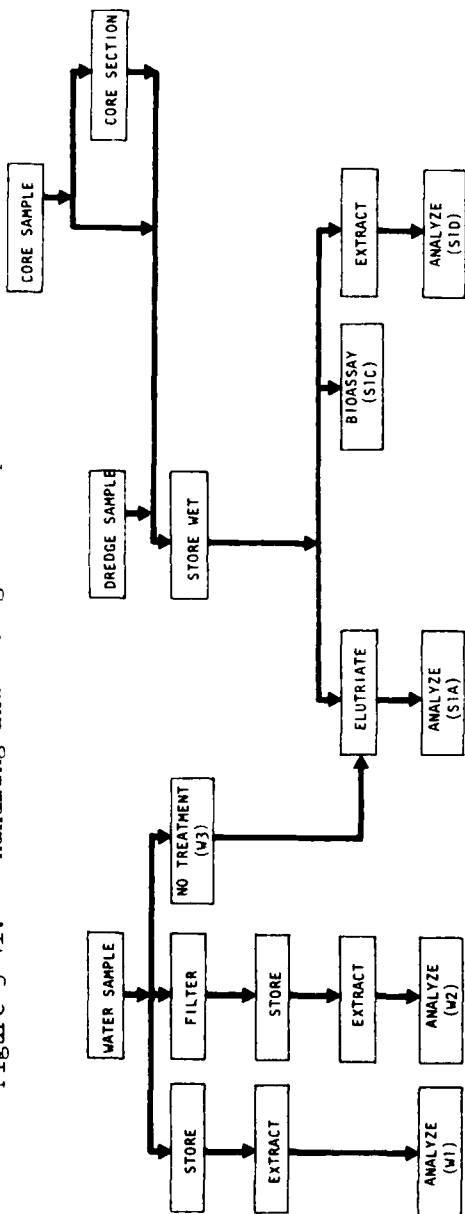

SAMPLE DESIGNATION	W1	W2	W3	S1A	S1C	S1D
PURPOSE	Total Water Conc.	Soluble Water Conc.	Used in Elutriate	Mobile Conc.	Bioavail-ability	Total Sediment Conc.
CONTAINER	G	G	G	G	G	G
SAMPLE TREATMENT	None	Filter	None	None	None	None
PRESERVATIVE	4°C	4°C	None	4°C (Minimize Air Contact.)	4°C	4°C
STORAGE TIME	Not known with certainty. Minimize as much as possible. Organophosphate stability can be increased by immediate extraction.					
DIGESTION SOLUTION	Hexane, Chloroform, and Benzene.					
SAMPLE VOLUME OR WEIGHT	1 liter	1 liter	-	1 liter	Variable	50 g

Procedure for Water Samples (W1, W2, S1A)²

Method 1: Hexane, Chloroform, Benzene Extraction

The procedure consists of three extractions on two sample aliquots. One aliquot is extracted with hexane to recover fenitrothion. The residual aqueous phase or solid residue is extracted with chloroform to recover phosphamidon and dimethoate. A second sample aliquot is extracted with benzene to recover 14 other orthophosphates.

Apparatus

Gas chromatograph: Varian 2800, MicroTek MT 220, or equivalent, equipped with a flame photometric detector, with independent power supply, electrometer, and 1.0-mV dual pen recorder

Gas chromatograph columns: three columns are specified. However, column a is most useful because the packing, consisting of OV-17 + QF-1, separates all 14 organophosphorous pesticides under isothermal analysis at 200°C. The other columns do not separate all residues but may be used for partial confirmation:

- a. 11 percent (w/w) OV-17 + QF-1 on Chromosorb Q, 80-100 mesh (available from Applied Science Laboratory, Inc.)
- b. 3.6 percent OV-101 and 5.5 percent OV-210 on Chromosorb W, 80-100 mesh, acid washed and DMCS treated
- c. 3 percent OV-225 on Chromosorb W HP, 80-100 mesh

Gas chromatograph operating conditions: all analyses are conducted under isothermal column conditions. Other operating temperatures are: injection port, 210°C; column temperature, 200°C; and detector temperature, 185°C. Gas flows should be optimized for maximum sensitivity with parathion. Suggested values are nitrogen, 80 ml/min; hydrogen, 150 ml/min; oxygen, 20 ml/min; and air, 10 ml/min

Disposable pipets

Magnetic stirrer and 5/8-in. Teflon-coated stirring bar

Kuderna-Danish (K-D) evaporator and associated glassware

Graduated centrifuge tubes, 15 ml with glass stoppers

Volumetric flasks, 10 ml

Hamilton micro-syringes, 10 μ l for sample injection and 100 μ l for preparation of standard solutions

Graduated pipets, 2 and 10 ml

Beaker, 250 ml for water bath

Heating plate

Vortex genie mixer

Rotary evaporator and associated equipment

Round-bottomed flasks, 500 and 300 ml

Separatory funnel, 2 l

Suction funnel to fit 500-ml round-bottomed flask

Nitrogen gas, prepurified or better

Reagents

All solvents must be of pesticide residue grade.

Hexane.

Chloroform.

Benzene.

Acetone.

Toluene.

Anhydrous sodium sulfate.

Analytical standards, obtainable from manufacturers. Working solutions (for injection) should be prepared weekly. The concentration of this standard should be chosen for one-half full-scale deflection. (See preparation of standard solutions.)

Preparation of standard solutions

Solvents: benzene or ethyl acetate are acceptable solvents for the preparation of standard solutions. Benzene is appropriate for the working solutions that are injected into the GLC.

Stock solution: in a 100-ml low actinic volumetric flask dissolve 100 mg of pure, analytical grade pesticide standard in a few milliliters of ethyl acetate and make up to volume with benzene. Shake flask well and keep in a refrigerator when not in use.

Working stock solution A: from the individual stock solutions at room temperature, pipet the following volumes of each pesticide listed below and transfer to a clean, 10-ml volumetric flask. Dilute to the 10-ml mark with benzene. Shake flask well and keep in a refrigerator when not in use.

1.0 ml diazinon
1.0 ml parathion
1.0 ml ethion
1.0 ml ronnel
1.0 ml malathion
2.0 ml methyl trithion
0.5 ml disyston

Working stock solution B: from the individual stock solutions at room temperature, pipet the following volumes of each pesticide listed on the next page and transfer to a clean, 10-ml volumetric

flask. Dilute to the 10-ml mark with benzene. Shake well and keep in a refrigerator when not in use.

1.0 ml methyl parathion
 0.5 ml thimet
 2.0 ml trithion
 2.0 ml ruelene

Nanogram solution (1.0 ng/ μ l): from the working stock solutions A and B, and the following stock solutions: imidan, guthion, and ethyl guthion, withdraw 100 μ l of each and transfer to a clean, 10-ml volumetric flask and dilute to the 10-ml mark with benzene. Shake well.

The resulting concentration of each pesticide standard in the nanogram solution is given in Table 3-22.

Table 3-22

Composition of Organophosphorous Nanogram Standard

<u>Individual Stock Solution</u>	<u>Amount Withdrawn for Working Stock ml</u>	<u>Concentration in Nanogram Standard ng/μl</u>
Azinphosethyl (Ethyl Guthion ^R)	-	10.0
Azinphosmethyl (Guthion ^R)	-	10.0
Carbophenothion (Trithion ^R)	2.0	2.0
Cruformate (Ruelene ^R)	2.0	2.0
Diazinon	1.0	1.0
Disulfoton (Disyston ^R)	0.5	0.5
Ethion	1.0	1.0
Imidan	-	10.0
Malathion	1.0	1.0
Methyl Parathion ^R	1.0	1.0
Methyl Trithion ^R	2.0	2.0
Parathion	1.0	1.0
Phorate (Thimet ^R)	0.5	0.5
Ronnel (Troiene ^R)	1.0	1.0

Picogram solution A (100 pg/ μ l): from the nanogram solution, remove 1.0 ml and transfer to a clean, 10-ml volumetric flask. Dilute to 10-ml mark with benzene. Shake well.

Picogram solution B (10 pg/ μ l): from the picogram standard A, remove 1.0 ml and transfer to a clean, 10-ml volumetric flask.

Dilute to 10-ml mark with benzene. Shake well.

Procedure

The procedure consists of three extractions on two aliquots of the water sample. One aliquot is successively extracted with hexane and chloroform to recover fenitrothion and phosphamidon, respectively. A second aliquot is then extracted with benzene to recover the remaining organophosphorous compounds.

Extraction of fenitrothion. Stir the sample on a magnetic stirrer so that the vortex formed at the surface almost reaches the bottom of the bottle. While stirring, add 25 to 50 ml hexane and 100 g sodium sulphate and tightly cover the bottle.

After stirring for 45 min, transfer the contents to a 2-l separatory funnel. Shake 2 min. Transfer the aqueous layer back to the sample bottle. Dry the hexane layer under rapid suction through a short column of anhydrous sodium sulphate, into a 300-ml round-bottomed flask and wash the column with 15 to 20 ml hexane.

Repeat the hexane extraction two more times using 25 to 50 ml of solvent each time. Collect and combine the extracts as before.

Concentrate the hexane on a rotary evaporator to less than 5 ml (40° to 50°C water bath).

Quantitatively transfer the hexane to a 15-ml centrifuge tube using a few milliliters hexane. Make up to 10 ml with hexane. Shake well or place on vortex genie for 30 sec. Analyze by GLC. If response is low, transfer the extract to a graduated centrifuge tube. Concentrate the sample to 0.5 ml in a 50°C water bath, also using a gentle stream of nitrogen. Reanalyze the concentrate.

Extraction of phosphamidon and dimethoate. To the aqueous solution from the first extraction add 25 to 50 ml chloroform and stir on a magnetic stirrer for 20 min. Transfer contents of sample bottle to a 2-l separatory funnel. Shake for 2 min.

Dry the chloroform layer by passing through a short column of anhydrous sodium sulphate into a 500-ml round-bottomed flask and wash the column with chloroform.

Rinse sample bottle with 25 to 50 ml of chloroform and

transfer to separatory funnel containing aqueous solution. Shake 2 min and dry chloroform layer as before. Repeat the extraction a third time.

Concentrate the chloroform on a rotary evaporator (40° to 50°C water bath) to less than 5 ml.

Quantitatively transfer the chloroform to a 15-ml centrifuge tube using a few milliliters of benzene. Make up to 10 ml with benzene.

Add 0.5 ml toluene to centrifuge tube and concentrate to 0.5 ml on 40° to 50°C water bath and using a gentle stream of nitrogen. Make up to 10 ml with benzene.

Examine sample by GLC. If response is low, transfer to a 15-ml graduated centrifuge tube. Place sample in a 50°C water bath and concentrate to 0.5 ml under a gentle stream of nitrogen. Reexamine by GLC.

Qualitative identification is based on relative retention time of parathion on two different columns using the phosphorous flame photometric detector. The sulfur mode may also be used to confirm an organophosphorous residue containing a sulfur atom. Phosphamidon contains no sulfur atom.

Extraction of other organophosphates. A fresh sample is extracted with benzene to quantify the 14 organophosphates listed in Table 3-23.

Stir the sample on a magnetic stirrer so that the vortex formed at the surface almost reaches the bottom of the bottle. While stirring, add 10 ml benzene and 100 g sodium sulfate and tightly cap the bottle. After stirring 45 min, let the layers separate and bring the organic phase into the neck of the bottle by addition of distilled water.

If an emulsion occurs, it can be broken up by mechanical stirring with a disposable pipet or by addition of some sodium sulfate. Water-soluble, polar organic solvents are not recommended because organophosphorous compounds will partition into these solvents and depressed recoveries are observed.

Table 3-23
Detection Limit for 14 Organophosphorous
Pesticides in 1-l Water Samples*

<u>Pesticide</u>	<u>Limit</u> <u>ppb</u>
Azinphosethyl (Ethyl Guthion ^R)	0.10
Azinphosmethyl (Guthion ^R)	0.10
Carbophenothion (Trithion ^R)	0.020
Crufomate (Ruelene ^R)	0.050
Diazinon	0.010
Disulfoton (Disyston ^R)	0.005
Ethion	0.010
Imidan	0.10
Malathion	0.010
Methyl Parathion	0.010
Methyl Trithion ^R	0.020
Parathion	0.010
Phorate (Thimet ^R)	0.005
Ronnel (Trolene ^R)	0.010

* One liter water extracted with 10 ml benzene and 5 ml extract concentrated to 0.5 ml. Eight-microliter injection on GLC at 2.56×10^{-9} amp full scale. Detection limit determined at about twice the noise.

Concentrate the extract by one of the following methods:

- a. Remove as much of the benzene extract as possible and place in a 15-ml centrifuge tube. Record exact volume. Add 0.5 ml toluene, place in 60°C water bath, and blow a gentle stream of nitrogen over the extract, concentrating it to 0.5 ml.

Make up volume (0.5 to 1.0 ml) with benzene and place on a vortex mixer for 10 sec to ensure homogeneity. Examine the sample by GLC.
- b. Remove as much of the benzene extract as possible and place in a 10-ml K-D tube. Record exact volume. Add 0.5 ml toluene and an ebullator and place a 3-ball Snyder condenser on K-D tube. Place in K-D block and wrap aluminum foil around condenser. Concentrate at a block temperature of 130°C to 0.5 ml (about 30 min). The K-D block must be preheated.

Make up to volume (0.5 to 1.0 ml) with benzene and place on a vortex mixer for 10 sec to ensure homogeneity. Examine the sample by GLC.

Qualitative identification is based on relative retention time to parathion on two different columns using the phosphorous

flame photometric detector. The sulfur mode may also be used to confirm those organophosphorous compounds with a sulfur atom in the structure.

Calculations

Peak height or area is employed to estimate concentrations of the organophosphorous residues in the water sample. The flame photometric detector is linear between 0.1 and 10 ng/injection for all these organophosphorous residues except ruelene. The calculations are as follows:

$$\text{Organophosphorous } \mu\text{g}/\ell = \frac{(A)(B)(C)(D)}{(E)(F)(G)(H)}$$

where

- A = nanograms of standard injected into GC
- B = peak height (or area) of sample
- C = volume of sample extract, ml
- D = final volume of extract after concentration, ml
- E = peak height (or area) of standard
- F = volume of extract injected into GC to produce response B, μl
- G = volume of water sample initially extracted, ℓ
- H = volume of extract removed for concentration, ml

Confirmation of identity

Two chemical derivatization techniques, using chromous chloride³ and pentafluorobenzyl bromide,⁴ respectively, for the confirmation of organophosphorous pesticide residues have been developed.

Both methods have merit. The CrCl_2 method is comparatively faster; but it is applicable to only three organophosphorous compounds. The pentafluorobenzyl ether method is applicable to eight compounds which were investigated. It is, therefore, more comprehensive; but it takes comparatively longer than the CrCl_2 method.

Additional information

Cleanup is often unnecessary when the FPD is used, as there are low background interferences. High concentration of sulphur in the extract, however, may lead to cross-channel interference and affect the response of the P-mode.

The FPD is highly specific for P- and/or S-containing compounds.

Phosphamidon exists as a mixture of isomers, the a-trans

and β -cis in an approximate proportion of 27:73. Since the β -cis isomer is the largest, it was chosen for use in the peak height quantification method.⁵

On most columns examined (see Tables 3-24 and 3-25), fenitrothion and β -phosphamidon had similar retention times and could not be resolved. Because of the solubilities of these organophosphorous compounds in various solvent systems, partitioning will successfully separate these two compounds.

Phosphamidon and dimethoate are water soluble and do not partition into the hexane phase of a hexane-water system. Fenitrothion is quantitatively recovered in the hexane.

Benzene will extract fenitrothion quantitatively but will also recover some of the phosphamidon and dimethoate.

A polar solvent will successfully extract the water-soluble phosphamidon and dimethoate from the aqueous solution. It was found that chloroform was the best solvent for quantitative results. Methylene chloride was more soluble in water (2 g/100) and depressed recoveries were observed.

The temperature of the water bath for concentrating extracts is critical for consistent quantitative recoveries. A temperature of 40°C is the best for recovery, but 50°C is more practical for time.

If the CHCl_3 extract is injected in the flame photometric detector, there is no difference in peak height from that of a benzene extract containing phosphamidon and dimethoate. However, when the CHCl_3 is vented off, anomalous and extraneous peaks may be observed on the electron capture detectors on the same instrument. Therefore, the chloroform is replaced by benzene for gas chromatographic analysis.

The use of sodium sulfate was beneficial in both the extraction of fenitrothion with hexane and phosphamidon and dimethoate with chloroform.

Ruelene response is nonlinear above 8.0 ng/injection.

The CrCl_2 reduction of nitro group on fenitrothion is applicable as a confirmatory test for fenitrothion. This reaction had no effect on either phosphamidon or dimethoate, even when used with ethylene diamine. Fenitrothion may also be confirmed as the PFB ether.

Table 3-24
Retention Time and Peak Height Data for Organophosphorous Pesticides *

Pesticide	Concentration of Standard ng/ μ l	Average Peak Height cm	** Coefficient of Variation of Peak Height %	+ Relative Retention Time t_R min	Coefficient of Variation of t_R %
Phorate (Thimet ^R)	0.5	15.14	2.73	0.28	0.57
Diazinon	1.0	14.34	2.39	0.34	0.56
Disulfoton (Di-Syston ^R)	0.5	10.86	2.52	0.41	0.63
Ronnel (Trolene ^R)	1.0	13.53	2.67	0.59	0.27
Methyl Parathion	1.0	9.69	4.31	0.79	0.16
Malathion	1.0	8.04	3.98	0.88	0.08
Parathion	1.0	9.75	4.33	1.00	0.00
Crufomate (Ruelene ^R)	2.0	5.17	15.24	1.21	0.87
Methyl Trithion ^R	2.0	6.10	5.13	2.07	0.24
Ethion	1.0	6.00	2.42	2.32	0.22
Carbophenothion (Trithion ^R)	2.0	6.44	2.61	2.50	0.25
Imidan ^R	10.0	11.24	7.17	6.00	0.24
Azinphosmethyl (Guthion ^R)	10.0	6.32	7.46	8.05	0.32
Azinphosethyl (Ethyl Guthion ^R)	10.0	7.80	3.32	9.81	0.33

* Column packed with OV-17/QP-1. Instrument operated isothermally at 200°C, attenuation 3.56×10^{-8} , amp full scale.

** Average of ten determinations with an 8- μ l injection.

† $t_R = 1.00$ for parathion (6.9 min).

Table 3-25
Retention Time for Organophosphorous Compounds
on OV-101/OV-210 at 200°C

<u>Compound</u>	<u>R.T.*</u>	<u>t_R**</u>
Dimethoate	0.85	0.54
Aminofenitrothion	1.05	0.67
α-Phosphamidon	1.20	0.79
Fenitrothion	1.35	0.86
Parathion	1.55	1.00
Fenitrothion-oxygen analogue	1.55	1.01
β-Phosphamidon	1.65	1.06

* Retention time in arbitrary units.

** Relative retention time to parathion (t_R parathion = 1.00). These values were determined using an integrator as a timer.

The hexane extraction recovers all 14 organophosphorous compounds with an 87 to 99 percent recovery at 10 ppb, with the exception of ruelene (30 percent). The retention time of ruelene does not interfere with those of phosphamidon or dimethoate.

Procedure for Sediment Samples (SID)

Method 1: Hexane Extraction^{2,6}

Apparatus

Gas chromatograph: Varian 2800, Microtek 220, or equivalent, equipped with a flame photometric detector and a recorder

Gas chromatograph columns: three columns are specified. Column a has the widest general applicability:

- a. 11 percent (W/W) OV-17 + QF-1 on Chromosorb Q, 80-100 mesh (available from Applied Science Laboratory, Inc.)
- b. 3.6 percent OV-101 and 5.5 percent OV-210 on Chromosorb W, 80-100 mesh, acid washed and DMCS treated
- c. 3 percent OV-225 on Chromosorb W HP, 80-100 mesh

Gas chromatograph operating conditions: all analyses are conducted under isothermal column conditions. Other operating temperatures are injection port, 210°C; column temperature, 200°C; detector temperature, 185°C. Suggested gas flows are nitrogen, 80 ml/min; hydrogen, 150 ml/min; oxygen, 20 ml/min; and air, 10 ml/min

Disposable pipets

Magnetic stirrer and 5/8-in. Teflon-coated stirring bar

Kuderna-Danish (K-D) evaporator and associated glassware

Graduated centrifuge tubes: 15 ml with glass stoppers

Volumetric flasks, 10 ml

Hamilton micro-syringes: 10 µl for sample injections and 100 µl for standard preparation

Graduated pipets, 2 and 10 ml

Beaker, 250 ml for water bath

Heating plate

Vortex genie mixer

Rotary evaporator and associated equipment

Round-bottomed flasks, 300 and 500 ml

Separatory funnel, 2 l

Suction funnel to fit 500-ml round-bottomed flask

Nitrogen gas, prepurified or better

Reagents

All reagents must be of pesticide grade quality.

Hexane.

Chloroform.

Benzene.

Acetone.

Toluene.

Anhydrous sodium sulfate.

Analytical standards: obtainable from manufacturers. Working solutions should be prepared weekly and working standards should be prepared daily. The concentration of these standards should be chosen for one-half full-scale deflection. Prepare standards according to directions provided in Method 1: Procedures for Water Samples. Standards should be stored in dark bottles and refrigerated.

Procedures

The sediment extraction procedure is similar to that used for water samples. Samples are sequentially extracted with hexane and chloroform. However, because of the reactivity of organophosphorous compounds, only wet sediment samples (S1D) should be considered for analysis.

Extraction of fenitrothion. Weigh 50 g wet sediment sample (S1D) and transfer to a 250-ml Erlénmeyer flask. Add 100 ml hexane and 10 ml deionized distilled water. Seal the flask and shake for 15 min.

Separate and retain the hexane layer. Repeat the extraction two more times. Combine the extracts and save the sediment slurry for chloroform extractions.

NOTE: Water is added to promote the desorption of pesticide residues from the sediment. The extraction efficiency can also be improved with an ultrasonic homogenizer.

Dry the hexane extract by passing through an anhydrous sodium sulfate column into the flask of a rotary evaporator. Wash the column with 15 to 20 ml hexane and add to the extract. Concentrate the extract to approximately 5 ml on a rotary evaporator in a 40° to 50°C water bath.

Quantitatively transfer the concentrate to a 15-ml centrifuge tube using hexane to wash the round-bottomed flask. Dilute to volume with hexane.

Mix the sample and inject a 10- μ l aliquot into the gas chromatograph. Adjust the concentrate volume as necessary by evaporation or dilution to bring the response on scale. Reanalyze the

concentrate.

Extraction of phosphamidon and dimethoate. Extract the sediment slurry aqueous extract with 100 ml chloroform. Shake for 15 min and separate the solvent layer. Repeat the chloroform extraction a second and a third time and combine the extracts.

Dry the extract by passing through an anhydrous sodium sulfate column. Wash the column with 15 to 20 ml chloroform. Combine the column washing and the sample extract in a round-bottomed flask. Reduce the volume to less than 5 ml using a rotary evaporator and a 40° to 50°C water bath.

Transfer the extract to a 15-ml centrifuge tube and add 0.5 ml toluene. Concentrate to approximately 0.5 ml in a 40°C water bath under a stream of nitrogen gas. Dilute to 10 ml with benzene and analyze by gas chromatography.

Extraction of other organophosphates. Extract a separate 50-g aliquot of the S1D sample with 100 ml of benzene. Shake for 15 min and separate the organic layer. Repeat the extraction two more times.

Combine the extracts and dry in an anhydrous sodium sulfate column. Transfer the extract to a round-bottomed flask. Reduce the volume to approximately 5 ml using a rotary evaporator and a 50°C water bath.

Quantitatively transfer the concentrate to a graduated centrifuge tube and add 0.5 ml toluene. Reduce the volume to 0.5 ml in a 50°C water bath. Dilute to volume with benzene and analyze by gas chromatography.

Calculations

Peak height or area is employed to estimate concentrations of the organophosphorous residues in the sediment sample. The calculations are as follows:

$$\text{Organophosphates } \mu\text{g/kg (wet weight)} = \frac{(A)(B)(C)(D)(1000)}{(E)(F)(H)(g)}$$

$$\text{Organophosphates } \mu\text{g/kg (dry weight)} = \frac{(A)(B)(C)(D)(1000)}{(E)(F)(H)(g)(\% S)}$$

where

A = nanograms of standard injected into GC

B = peak height (or area) of sample response

C = volume of sample extract, ml

D = final volume of extract after concentration (if necessary),
ml

E = peak height (or area) of standard response

F = volume of extract injected into GC to produce response B, μ l

H = volume of extract removed for concentration (if necessary), ml

g = wet weight of sediment initially extracted, g

% S = sediment percent solids as a decimal fraction

References

1. American Public Health Association. Standard Methods for the Examination of Water and Wastewater Including Bottom Sediments and Sludges. 14th Edition. APHA; New York, New York. 1193 p. (1976).
2. Environment Canada. "Analytical Methods Manual." Inland Waters Directorate, Water Quality Branch; Ottawa, Ontario, Canada (1974).
3. Forbes, M. A., Cochrane, W. P., and Greenhalgh, R. "Confirmatory Identification of Organophosphorous Insecticides with Various Reducing Agents." CIC-CCIW Symposium on Water Parameters, 19-21 November 1973; Burlington, Ontario, Canada (1973).
4. Coburn, J., and Chau, A. S. Y. "Confirmation of Pesticide-Residue Identity. 8. Organophosphorus Pesticides." J. Ass. Offic. Anal. Chem. 57:1272-1278 (1974).
5. Anlinker, R., and Beriger, E. "Phosphamidon, Residue Reviews," Gunther, F. A. (Ed.), 37:1-14 (1971).
6. Walton, A. "Methods for Sampling and Analysis of Marine Sediments and Dredged Materials." Ocean Dumping Report 1. Department of Fisheries and Environment; Ottawa, Ontario, Canada. 74 p. (1978).

POLYNUCLEAR AROMATIC HYDROCARBONS

The basic common structure of this family of compounds is a fused aromatic ring. The source of these compounds is diverse as there are both natural and man-derived sources.^{1*} However, the concern about these chemicals results from the fact that many of them are potentially carcinogenic.

Polynuclear aromatic hydrocarbons (PAH) are separated from the original sample by extraction with dichloromethane, methanol, or ethanol. The extracts are then purified by solvent partitioning. The purified extracts are quantified using gas chromatography or fluorimetry.

Sample Handling and Storage

Samples for polynuclear aromatic hydrocarbon (PAH) analysis should be handled and stored in glass or stainless steel containers. During the collection phase, care should be taken not to contaminate the sample with lubricants or other hydrocarbon products as they may contain PAH compounds.

Of the three methods of storing sediment samples, wet, dry, or frozen, no evidence was found that any one method is advantageous or disadvantageous to use. Similarly, appropriate storage times have yet to be defined. In the absence of definitive data, it is recommended that the procedure for chlorinated hydrocarbon pesticides be followed and PAH samples be extracted as soon as practical (Figure 3-42).

Procedure for Water Samples (W1, W2, S1A)^{2,3}

Method 1: Dichloromethane Extraction/Gas Chromatography

Apparatus

Ultrasonic homogenizer

Filtering apparatus

Vacuum pump

Separatory funnels

* References can be found on page 3-347.

Figure 3-42 Handling and storage of samples for polynuclear aromatic hydrocarbon analysis

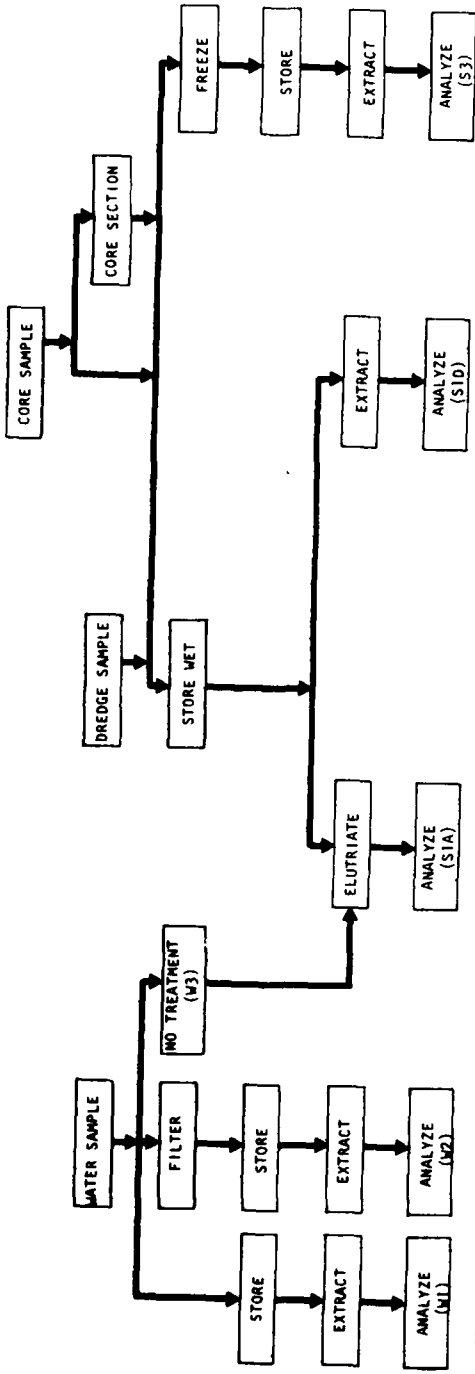

SAMPLE DESIGNATION	W1	W2	W3	S1A	S1D	S3
PURPOSE	Total Water Conc.	Soluble Water Conc.	Used in Elutriate	Mobile Conc.	Total Sediment Conc.	Total Sediment Conc.
CONTAINER	G	G	G	G	G	G
SAMPLE TREATMENT	None	Filter	None	None	None	Freeze
PRESERVATIVE	4°C	4°C	None	4°C (Minimize Air Contact. Keep Field Moist.)	4°C	None
STORAGE TIME	-----Extract as soon as possible.-----					
DIGESTION SOLUTION						
SAMPLE VOLUME OR WEIGHT	>1 liter	>1 liter		>1 liter	25-100 g	25-100 g

Vigreux distillation apparatus

Gas chromatography: Hewlett-Packard 7620 or equivalent. Balanced dual columns (3.5 m by 50 mm o.d., stainless steel columns), packed with 3 percent OV-7 on 60/80 mesh acid washed and DCMS treated Gas Chrom Q. Use a nitrogen carrier (35 ml/min) and dual FID detectors. Maintain a temperature of 26°C for 8 min and then increase the temperature to 300°C at a rate of 8°/min

Reagents

Dichloromethane.

Methanol.

Cyclohexane.

Dimethyl Sulfoxide: when GC analysis is used, it may be necessary to purify commercially available DMSO. Add 200 ml DMSO to 200 ml glass distilled water. Extract once with 400 ml redistilled iso-octane and discard the iso-octane. Using a rotary evaporator at 90° to 95°, reduce the solvent volume until 225 ml of liquid (mostly water) has been collected in the condenser trap. The remaining DMSO is ready for use.

Procedure

Add 300 ml dichloromethane to 5 l of water sample. Mix the sample for 5 min with an ultrasonic homogenizer. The instrument should be set at approximately 80 percent of full scale.

A second 5-l water sample should be spiked with 0.1 to 0.2 ml of a dichloromethane solution of standard PAH. This sample should be carried through the analytical procedure as an indicator of extraction efficiency.

Stopper the mixed sample and allow to sit overnight in the absence of light. Decant as much of the aqueous phase as possible. Filter the remaining liquid under vacuum through a glass fiber filter. Wash the filter with a dichloromethane solution and add to the filtrate. Transfer to a separatory funnel and drain off the dichloromethane layer.

Transfer the sample to a Vigreux distillation apparatus and reduce the sample volume. Dissolve the sample in 100 ml 4:1 methanol-distilled water.

Extract the PAH into 30 ml cyclohexane. Add 15 ml dimethyl-sulfoxide (DMSO) to the cyclohexane extract and shake for 3 min. Extract the cyclohexane layer with two more 15-ml portions of DMSO.

Combine the DMSO extracts and dilute with 90 ml distilled

water. Add 25 ml cyclohexane, shake for 5 min, and draw off the cyclohexane layer. Extract the DMSO solution with a second 25-ml portion of cyclohexane. Shake the sample for 5 min during the extraction process.

Combine the cyclohexane extracts and transfer the sample to a Vigreux distillation apparatus. Evaporate the sample to near dryness. Dilute the sample to a convenient volume and analyze by gas chromatography.

NOTE: The initial dichloromethane extract may be analyzed directly by GC. However, the DMSO modification is an efficient purification procedure (90 to 100 percent recovery for most PAH).

Calculations

The PAH concentration can be calculated as follows:

$$\text{PAH } \mu\text{g}/\ell = \frac{(A)(B)(C)}{(D)(E)(F)}$$

where

A = weight of standard PAH injected, μg

B = observed peak height or area of sample

C = final sample extract volume, ml

D = observed peak height or area produced by standard A

E = volume of sample injected, ml

F = volume of sample initially extracted, ℓ

Procedures for Sediment Samples (S1D, S2, S3)

Method 1: Methanol Extraction/UV Analysis⁴

Apparatus

Soxhlet extraction apparatus

Sodium sulfate column: extract anhydrous sodium sulfate with 1:1 benzene-methanol and dry at 120°C. Pack in appropriate size column

Roto-evaporator

Column packed with copper turnings

Sephadex LH-20 column: condition 20 g Sephadex LH-20 in 1:1 benzene-methanol. Wash in the same solvent and pack in a glass column, 1.6 cm I.D., 38 cm height

Alumina-Silica gel column: activate silica gel and alumina for 24 hr at 210°C. Deactivate with 3 percent water. Pack a 1.2 cm I.D. glass column with 4 ml deactivated silica gel and 4 ml deactivated alumina

Silica gel column: activate silica gel at 210°C for 24 hr. Slurry in n-pentane and pack 12 ml in a 1.2 cm I.D. glass column.

Alumina column: activate alumina at 210°C for 24 hr. Deactivate with 1 percent water. Pack 5 ml in a 0.6 cm I.D. glass column

Hamilton syringes

Electrobalance

Recording UV spectrophotometer with 10 cm quartz cells

Reagents

All reagents are analytical grade. Solvents should be redistilled when necessary.

Methanol.

Benzene.

n-Pentane.

Anhydrous sodium sulfate.

Silica gel.

Alumina.

Sephadex LH-20.

Standard PAH compounds.

2,4,7-trinitro-9-fluorenone.

Procedure

Blend the sediment sample. Weigh out 100 to 150 g wet

weight equivalent of the sediment and transfer to a Soxhlet extraction thimble. Place 275 ml methanol and the sample in a Soxhlet extraction apparatus and extract for 24 hr. Add 75 ml benzene and extract for an additional 24 hr.

Transfer the extract to a separatory funnel and partition the PAH's into n-pentane with three 75-ml aliquots of the solvent. Wash the combined n-pentane extract with two 250-ml rinses of distilled water. Dry the extract by passing through an anhydrous sodium sulfate column and collect in a round-bottomed flask. Concentrate the n-pentane extract to approximately ml on a roto-evaporator at room temperature.

Transfer the sample to a column of copper turnings to remove elemental sulfur. Elute the sample from the column using benzene-pentane (1:1) as an eluent. Reduce the eluate volume to approximately 1 ml.

Place the sample on the Sephadex LH-20 column and elute with benzene-methanol (1:1) at a flow rate of 6 ml/min. Discard the first 50 ml of eluate. Collect the second 50 ml and evaporate to dryness in a rotary evaporator at room temperature.

NOTE: The column can be reused by washing with 100 ml of solvent (1:1 benzene-methanol) and repacking the column as necessary to maintain the flow rate.

Take up the aromatic residue in 1 ml n-pentane and transfer to an alumina-silica gel column. Elute the column with 20 ml n-pentane and discard. Rinse the rotary evaporation flask with 2 ml methylene chloride and add to the alumina-silica gel column. Elute the column with an additional 13 ml methylene chloride and retain the eluate in a 100-ml round-bottomed flask.

Add 20 mg Trinitrofluorenone (TNF) to the sample and evaporate to complete dryness. Wash the sample 5 times with 2 ml rinses of n-pentane. Withdraw each wash through a cotton pad using a pipet and discard.

Dissolve any excess TNF and the PAH complexes in methylene chloride and transfer to an activated silica gel column. Elute the PAH complexes with 75 ml methylene chloride and evaporate to near dryness (0.5 - 1.0 ml).

Transfer a small aliquot (< 100 µl) to the aluminum pan

of an electrobalance, air dry, and weigh.

Dry the remainder of the PAH concentrate under a stream of nitrogen at room temperature. Dissolve the residue in 0.5 ml 1:4 methylene chloride: pentane and apply to an alumina column. This solution should not contain more than 200 µg of material. Elute the sample with pentane containing an increasing percentage of methylene chloride; 95 ml 4 percent methylene chloride, 70 ml 15 percent methylene chloride, 30 ml 20 percent methylene chloride, 30 ml 30 percent methylene chloride, and 20 ml 100 percent methylene chloride.

Collect the eluate in seven fractions based on general ring types. The volume of each fraction and the compounds in each fraction are as follows:

<u>Fraction No.</u>	<u>Volume, ml</u>	<u>Compounds</u>	<u>Wavelength, nm</u>
1	20	PCB's	
2	25	Phenanthrene	293
3	60	Anthracene	252
		Pyrene	333
		Fluoranthene	286
4	20	Chrysene	267
		Benzanthracene	287
5	35	Benzopyrenes	383
		Perylene	435
6	35	Benzoperylene	382
		Anthanthrene	428
7	25	Coronene	338

Adjust the final volume of each fraction to 25 ml by evaporation or dilution with methylene chloride. Determine the spectra of each fraction with a recording UV spectrophotometer using a 10-cm quartz cell. Compare the sample spectra to standard PAH spectra and quantify each PAH at the specific wavelength listed above.

Calculations

Calculate the concentration of each PAH compound as follows:

$$\text{PAH } \mu\text{g/kg (wet weight)} = \frac{(X)(0.025)(1000)}{g}$$

$$\text{PAH } \mu\text{g/kg (dry weight)} = \frac{(X)(0.025)(1000)}{(g)(\% S)}$$

where

X = PAH concentration in extract, µg/l

V = final volume of fraction extract, l

w = wet weight of sediment sample extracted, g

$\% S$ = sediment percent solids (expressed as a decimal fraction)

Method 2: Ethanol Extraction/UV Spectrophotometry⁵

Apparatus

Erlenmeyer flasks

Separatory funnels

Florisil column: add 30 g florisil to a 40- by 400-mm glass column fitted with a coarse fitted glass disc. Cover with 60 g Na_2SO_4

Roto-evaporator

Thin-layer chromatography plates and development tanks

Fine fitted Büchner funnel

Recording spectrophotofluorimeter, Aminco-Bowman or equivalent

Reagents

All reagents should be of analytical grade.

Ethanol.

Potassium hydroxide.

Boiling stones.

Glass wool.

Iso-octane.

Benzene.

Dimethyl sulfoxide: if samples are to be quantified by gas chromatography, purify the DMSO as follows:

Add 200 ml DMSO to 200 ml glass distilled water. Extract once with 400 ml redistilled iso-octane. Discard the iso-octane. Using a rotary evaporator at 90° to 95°C, reduce the solvent volume until 225 ml of liquid (mostly water) has been collected in the condenser trap. The remaining DMSO does not have to be dried before use.

Na_2SO_4 .

Toluene.

Hexadecane.

PAH standards.

Procedure

Blend a sediment sample and weigh out a 10- to 20-g wet weight equivalent of the sample. Transfer to a flask and add 100 ml

ethanol, 5 g KOH, and a few boiling stones. Reflux the sample for 1.5 hr.

Pour the suspension into a 250-ml Erlenmeyer flask and allow the sediment to settle by gravity for 5 min. Decant the alcohol through a glass wool plug into a 1-l separatory funnel containing 150 ml distilled water.

Wash the sediment twice with 50-ml portions of ethanol. Filter each wash through the glass wool plug and add to the separatory funnel.

Extract the water/ethanol mixture three times with 200 ml iso-octane. Combine the iso-octane extracts and wash four times with 200-ml portions of warm (60°C) water.

Wash a Florisil column with 100 ml of iso-octane. Place the iso-octane extract on the column and allow the solvent to drain. Wash the column with two 100-ml portions of fresh iso-octane and allow the column to drain briefly between each addition.

Elute the PAH's from the column with three 100-ml portions of benzene. Collect the eluate in a round-bottomed flask and reduce to 5 ml on a rotary evaporator. Add 50 ml iso-octane and reduce the volume to 5 ml, again on a rotary evaporator.

Extract the iso-octane extract with three 5-ml portions of dimethyl sulfoxide (DMSO). Combine the DMSO extracts with 30 ml distilled water.* Extract the PAH back into iso-octane with two 10-ml portions of the solvent. Combine the iso-octane extracts and wash three times with 20 ml distilled water. Dry the sample by passage through 10 g Na₂SO₄ in a 15-ml coarse fritted glass Büchner funnel.

* The following procedure can be used if the PAH are to be quantified using gas chromatography:

Add the DMSO extract to 45 ml distilled water. Extract the aqueous solution with two 12.5-ml portions of cyclohexane. Shake the mixture 5 min each time and draw off the cyclohexane layer. Combine the extracts and transfer to a 15-cm Vigreux column. Evaporate to near dryness, transfer to a pear-shaped flask. Rinse the Vigreux flask with cyclohexane and add the rinsing to the pear-shaped flask. Continue evaporating the sample to a final volume of approximately 20 µl.

Analyze using a gas chromatograph. Use the instrument operating conditions specified for water samples.

Reduce the sample size to approximately 0.1 ml using rotary evaporation and a stream of nitrogen. Spot the sample and a 10-ng PAH standard on a cellulose-acetate thin-layer plate. Support the plate approximately 5 cm from the bottom of a development tank with the plate extending approximately 2 cm above the tank. Add sufficient developing solution (ethanol:toluene:water, 17:4:4) to wet the bottom of the plate. Partially cover the top of the development tank.

Locate the PAH band with long wave ultra-violet light. The PAH band should be the lowest band on the plate with an approximate R_f of 0.3 after 2 hr of development.

Scrape off the PAH band while still wet and place in a 15-ml fine fritted glass Büchner funnel. Wash the sample four times with 4-ml portions of hot (65°C) methanol. Use gentle suction to separate the solvent. Add the combined methanol extract to 10 ml of 1:4 hexadecane-iso-octane. Reduce the sample volume to 2 ml on a roto-evaporator.

Exite the samples and standards, containing no more than 200 mg PAH, at 365 nm with a spectrophotofluorimeter. Record the sample spectrum from 375 to 500 nm. Quantify the PAH concentration based on the maxima at 430 nm relative to an artificial baseline between 418 and 448 nm.

Calculations

Prepare a standard curve of ng PAH vs. sample fluorescence. Calculate the weight of PAH in the sample extracts:

$$\text{PAH } \mu\text{g/kg (wet weight)} = \frac{(X)(V)(1000)}{g}$$

$$\text{PAH } \mu\text{g/kg (dry weight)} = \frac{(X)(V)(1000)}{(g)(\% S)}$$

where

X = PAH concentration in final extract, $\mu\text{g}/\ell$

V = volume of final extract, ℓ

g = wet weight of sediment extracted, g

% S = sediment percent solids (expressed as a decimal fraction)

References

1. Blumer, M., and Youngblood, W. W. "Polycyclic Aromatic Hydrocarbons in Soils and Recent Sediments." *Science* 188:53-55 (1975).
2. Acheson, M. A., Harrison, R. M., Perry, R., and Wellings, R. A. "Factors Affecting the Extraction and Analysis of Polynuclear Aromatic Hydrocarbons in Water." *Water Research* 10:207-212 (1976).
3. Hoffman, D., and Wynder, E. L. "Short Term Determination of Carcinogenic Aromatic Hydrocarbons." *Anal. Chem.* 32:295-296 (1960).
4. Giger, W., and Blumer, M. "Polycyclic Aromatic Hydrocarbons in the Environment: Isolation and Characterization by Chromatography, Visible, Ultraviolet, and Mass Spectrometry." *Anal. Chem.* 46:1163-1171 (1974).
5. Dunn, B. P. "Techniques for Determination of Benzo(a) Pyrene in Marine Organisms and Sediments." *Environ. Sci. and Tech.* 10: 1018-1021 (1976).

PHENOLICS

Phenols are hydroxy-derivatives of benzene and related compounds. The colorimetric procedures used to quantify phenols are not specific for one phenolic compound, but to the general phenol structure. Because of the difficulty in preparing standard phenol mixtures for all samples, phenolic compounds are reported as an equivalent amount of phenol.

Sample Handling and Storage

Phenol samples should be stored in glass containers. When immediate analysis is not possible, samples may be preserved with the addition of 1 g/l copper sulfate and acidification with phosphoric acid to pH < 4. The samples should also be maintained at 4°C until analysis. However, even with the use of these preservatives, samples should be analyzed within 24 hr. This information is summarized in Figure 3-43.

It is recommended that only wet sediment samples be utilized for phenol analysis. This cautionary approach is based on the fact that dried samples may lose phenol as a result of biological degradation, and both dried and frozen samples may lose phenol as a result of volatilization during the drying and/or thawing cycles. Samples should also be processed within the 24-hr period specified for water samples.

Procedures for Water Samples (W1, W2, S1A)

Method 1: Distillation, 4-aminocantipyrene Colorimetric^{1,2,3*}

Apparatus

Distillation apparatus, all glass consisting of a 1-l pyrex distilling apparatus with Graham condenser

pH meter

Spectrophotometer, for use at 460 or 510 nm

* References for this section are on page 3-360.

Figure 3-43. Handling and storage of samples for phenol analysis

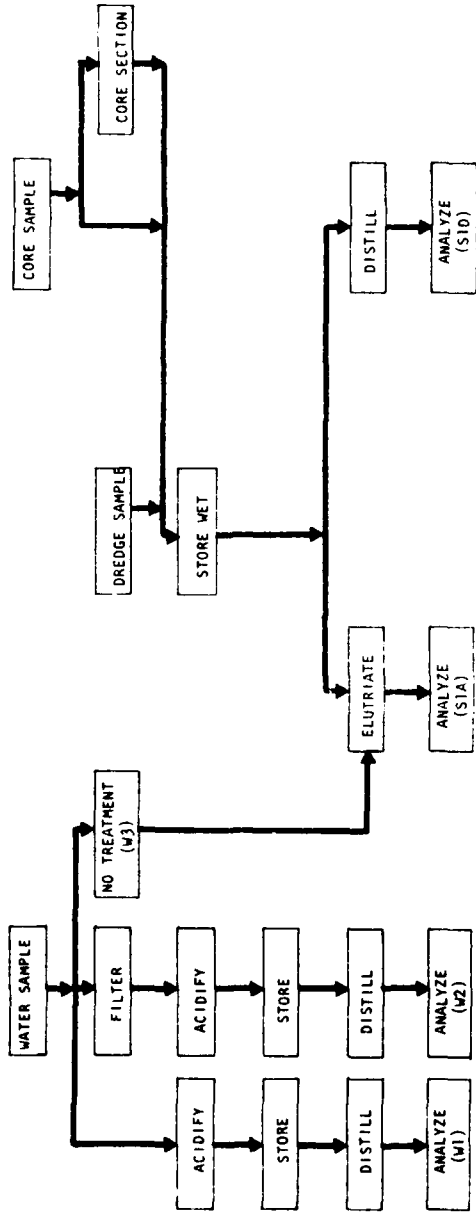

3-349

SAMPLE DESIGNATION	W1		W2		W3		S1A		S1D			
	PURPOSE	Total Water Conc.	Soluble Water Conc.	Used in Elutriate	Mobile Conc.	Total Sediment Conc.	CONTAINER	SAMPLE TREATMENT	PRESERVATIVE	STORAGE TIME	DIGESTION SOLUTION	SAMPLE VOLUME OR WEIGHT
		G	G	G	G	G						
		None	Filter	None	None	None						
		H ₃ PO ₄ CuSO ₄ 4°C	H ₃ PO ₄ CuSO ₄ 4°C	None	4°C (Minimize Air Contact. Keep Field Moist.)	4°C						
		24 hr	24 hr	24 hr	24 hr	24 hr						
		Distillation	Distillation	-	Distillation	Distillation						
		500 ml	500 ml	-	500 ml	10-50 g						

Funnels

Filter paper

Membrane filters

Separatory funnels, 500 or 1000 ml

Nessler tubes, short or long

Reagents

Phosphoric acid solution, 1 + 9: dilute 10 ml of 85 percent H_3PO_4 to 100 ml with distilled water.

Copper sulfate solution: dissolve 100 g $CuSO_4 \cdot 5H_2O$ in distilled water and dilute to 1 l.

Buffer solution: dissolve 16.9 g NH_4Cl in 143 ml conc. NH_4OH and dilute to 250 ml with distilled water. Two ml should adjust 100 ml of distillate to pH 10.

Aminoantipyrine solution: dissolve 2 g of 4 AAP in distilled water and dilute to 100 ml.

Potassium ferricyanide solution: dissolve 8 g of $K_3Fe(CN)_6$ in distilled water and dilute to 100 ml.

Stock phenol solution: dissolve 1.0 g phenol in freshly boiled and cooled distilled water and dilute to 1 l. 1 ml = 1 mg phenol.

Working solution A: dilute 10 ml stock phenol solution to 1 l with distilled water. 1 ml = 10 μ g phenol.

Working solution B: dilute 100 ml of working solution A to 1000 ml with distilled water. 1 ml = 1 μ g phenol.

Chloroform.

Procedure

The first step in the procedure is a distillation to isolate phenolic compounds from possible interfering substances in the sample. Add sufficient 1 + 9 phosphoric acid to a 500-ml water sample (W1, W2, S1A) to lower the pH to approximately 4. Add 5 ml copper sulfate solution to the sample.

NOTE 1: Omit the addition of H_3PO_4 and $CuSO_4$ to the sample if these reagents have previously been added to the sample as preservatives.

NOTE 2: The addition of H_3PO_4 and $CuSO_4$ serves the dual purposes of inhibiting the biological degradation of phenol and removing the interference due to sulfur compounds.

Transfer the acidified sample to the distillation apparatus. Distill the sample and collect the distillate. When 450 ml of distillate have been collected, temporarily stop the

distillation process. After boiling has ceased in the distillation flask, add 50 ml warm distilled water to the flask. Resume sample distillation until a total of 500 ml distillate has been collected.

If the distillate is turbid, filter the sample through a 0.45- μ pore-sized membrane filter. Analyze the sample using either direct colorimetry (Method 1A) or chloroform extraction (Method 1B). The direct method is for samples with phenol concentrations in the range of 40 to 1000 $\mu\text{g}/\ell$ and the extraction technique is for samples with phenol concentrations in the range of 5 to 50 $\mu\text{g}/\ell$.

Method 1A: Direct Colorimetry. Prepare the following set of phenol standards in 100-ml volumetric flasks by pipetting the indicated volume of phenol working solution A.

<u>ml of working solution A</u>	<u>Phenol conc., $\mu\text{g}/\ell$</u>
0	0.0
0.5	50.0
1.0	100.0
2.0	200.0
5.0	500.0
8.0	800.0
10.0	1000.0

Pipet either 100 ml of standard, 100 ml of distillate, and/or an aliquot of the sample diluted to 100 ml into an Erlenmeyer flask. Add 2 ml of ammonia buffer solution and mix. The resultant pH should be 10 ± 0.02 .

Add 2.0 ml aminoantipyrine solution and mix. Add 2.0 ml potassium ferricyanide solution and mix. Allow 15 min for color development and measure the absorbance of the sample at 510 nm relative to a reagent blank.

Method 1B: Chloroform Extraction. Low concentrations of phenol can be concentrated by chloroform extraction to enhance detection. The phenol-aminoantipyrine color complex is developed as in Method 1A and concentrated by chloroform extraction.

Prepare a series of phenol standards by pipetting the indicated volume of phenol working solution B into a series of separatory funnels and diluting each to 500 ml with distilled water.

<u>ml of working solution B</u>	<u>Phenol conc., $\mu\text{g}/\text{l}$</u>
0.0	0.0
3.0	6.0
5.0	10.0
10.0	20.0
20.0	40.0
25.0	50.0

Place 500 ml of sample distillate or an aliquot diluted to 500 ml in a separatory funnel. The distillate should be prepared as described in Method 1A and should not contain more than 25 μg phenol. Add 10 ml ammonia buffer solution and mix. The pH of the sample should be 10 ± 0.02 .

Add 3.0 ml aminoantipyrine solution and mix. Add 3.0 ml potassium ferricyanide solution and mix.

After 3 min, extract with 25 ml of chloroform. Shake the separatory funnel at least 10 times, let CHCl_3 settle, shake again 10 times, and let chloroform settle again.

Filter the chloroform extracts through filter paper. Do not add any chloroform to compensate for any chloroform that may be lost during the filtration process.

Measure the absorbance of the standards and samples at 460 nm relative to a reagent blank.

Calculations

Prepare a standard curve by plotting the absorbance value of standards vs. the corresponding phenol concentrations. Obtain concentration value of sample directly from standard curve.

Method 2: Distillation, MBTH Colorimetric¹

Phenolic compounds are separated from the sample matrix by distillation. The phenols are coupled with 3-methyl-2-benzothiazolinone hydrazone hydrochloride (MBTH) in an acidic solution. The complex is then oxidized with ceric ammonium sulfate to produce a color proportional to the original phenolic concentration.

Apparatus

Distillation apparatus: all glass consisting of a 1-l pyrex distilling apparatus with Graham condenser

pH meter
Spectrophotometer
Funnels
Filter paper
Membrane filters
Separatory funnels

Reagents

Copper sulfate solution: dissolve 100 g $\text{CuSO}_4 \cdot 5\text{H}_2\text{O}$ in distilled water and dilute to 1 l.

Sulfuric acid, 1 N: add 28 ml of conc. H_2SO_4 to 900 ml of distilled water, mix, and dilute to 1 l.

MBTH solution, 0.05 percent: dissolve 0.1 g of 3-methyl-2-benzothiazolinone hydrazone hydrochloride in 200 ml of distilled water.

Ceric ammonium sulfate solution: add 2.0 g of $\text{Ce}(\text{SO}_4)_2 \cdot 2(\text{NH}_4)_2\text{SO}_4 \cdot 2\text{H}_2\text{O}$ and 2.0 ml of conc. H_2SO_4 to 150 ml of distilled water. After the solid has dissolved, dilute to 200 ml with distilled water.

Buffer solution: dissolve in the following order, 8 g of sodium hydroxide, 2 g EDTA (disodium salt), and 8 g boric acid in 200 ml of distilled water. Dilute to 250 ml with distilled water.

Working buffer solution: make a working solution by mixing an appropriate volume of buffer solution with an equal volume of ethanol.

Chloroform.

Stock phenol: dissolve 1.00 g phenol in 500 ml of distilled water and dilute to 1000 ml. Add 1 g CuSO_4 and 0.5 ml conc. H_2SO_4 as a preservative. 1.0 ml = 1.0 mg phenol.

Standard phenol solution A: dilute 10.0 ml stock phenol solution to 1000 ml. 1.0 ml = 0.01 mg phenol.

Standard phenol solution B: dilute 100.0 ml of standard phenol solution A to 1000 ml with distilled water. 1.0 ml = 0.001 mg phenol.

Procedure

Transfer 500 ml of sample (W1, W2, and/or S1A) to a 1-l distillation flask. Add 5 ml 10 percent copper sulfate solution and adjust the pH to approximately 4 with 1 N sulfuric acid.

Distill over approximately 450 ml of sample and interrupt the distillation process. Add 50 ml warm distilled water to the distillation flask and resume distillation until a total of 500 ml

distillate has been collected. If the distillate is turbid, filter through a prewashed, 0.45- μ pore-sized membrane filter.

If the phenol concentration is above 50 $\mu\text{g}/\ell$, the concentration can be determined directly (Method 2A). If the phenol concentration is less than 50 $\mu\text{g}/\ell$, the colored complex is concentrated by solvent extraction prior to quantification (Method 2B).

Method 2A: Direct Colorimetry. To 100 ml of standard, distillate, or sample aliquot diluted to 100 ml, add 4 ml MBTH solution and mix.

Allow 5 min for the coupling reaction and add 2.5 ml ceric ammonium sulfate solution. Mix.

After a second 5-min period, add 7 ml working buffer solution. Wait 15 min for color development and measure the sample absorbance at 520 nm relative to a reagent blank. The color is stable for 4 hr.

Method 2B: Solvent Extraction. Transfer the 500-ml distillate to a 1- ℓ separatory funnel and add 4 ml MBTH solution. Mix and wait 5 min.

After 5 min, add 2.5 ml ceric ammonium sulfate solution. Wait 5 min and add 7 ml of working buffer solution.

Allow 15 min for color developments and add 25 ml chloroform. Shake the separatory funnel at least 20 times. Drain the chloroform layer through filter paper.

Measure the absorbance of the sample at 490 nm relative to a reagent blank.

Calculations

Prepare a standard curve by plotting the absorbance of the phenol standards against known concentrations. Compare sample absorbance measurements to the standard curve to determine phenol concentrations in the samples.

Procedures for Sediment Samples (SID)

The phenol procedure for sediments is essentially the same as that used for water samples. Phenols are separated from the sample matrix and possible interferences by distillation. Phenols in the distillate are complexed with either 4-aminoantipyrine or 3-methyl-2-benzothiazolinone hydrazone hydrochloride (MBTH) and measured colorimetrically.

Method 1: Distillation, 4-aminoantipyrine Colorimetric⁴

Apparatus

Distillation apparatus, all glass, with 1-ℓ distillation flask

Separatory funnels, 1 ℓ, with Teflon stopcocks

Spectrophotometer, with 460-nm filter

Reagents

Phenol stock solution: dissolve 1.000 g phenol in distilled water and dilute to 1 ℓ with distilled water. 1.0 ml = 1.0 mg phenol.

Phenol working solution: pipet 20.0 ml phenol stock solution into a 1-ℓ volumetric flask and dilute to volume with distilled water. 1.0 ml = 20 µg phenol. Prepare daily.

Phenol standard solution: pipet 25.0 ml phenol working solution into a 500-ml volumetric flask and dilute to volume with distilled water. 1.0 ml = 1.0 µg phenol. Prepare daily.

Ammonium chloride solution: dissolve 67.5 g NH_4Cl in 570 ml conc. NH_4OH and dilute to 1 ℓ with distilled water.

Aminoantipyrine solution: dissolve 2.0 g 4-aminoantipyrine in distilled water and dilute to 100 ml.

Potassium ferricyanide solution: dissolve 8.0 g $\text{K}_3\text{Fe}(\text{CN})_6$ in distilled water and dilute to 100 ml.

Chloroform, reagent grade.

Phosphoric acid solution: mix 10 ml phosphoric acid with distilled water and dilute to 100 ml.

Copper sulfate solution: dissolve 10 g $\text{CuSO}_4 \cdot 5\text{H}_2\text{O}$ in distilled water and dilute to 100 ml.

Procedure

Place an aliquot of wet sediment (SID), 10 to 50 g, containing not more than 50 µg phenol, in a 1-ℓ distillation flask. Add 550 ml distilled water.

Add 5 ml 10 percent copper sulfate solution, 5 ml phosphoric acid solution, and a few drops of methyl orange indicator.

NOTE: The addition of CuSO_4 and H_3PO_4 can be omitted if the sample was previously preserved.

Add a few boiling stones and distill 500 ml of distillate.

NOTE: If oil is present in the distillate, filter the sample through two thicknesses of dry No. 12 Whatman filter paper to remove the oil. Collect the filtered sample in a 1- ℓ separatory funnel.

The phenol concentration can be quantitated using direct colorimetry if the concentration is above 50 $\mu\text{g}/\ell$ (Method 1A) or by solvent extraction if the concentration is less than 50 $\mu\text{g}/\ell$ (Method 1B).

Method 1A: Direct Colorimetry. Pipet 100 ml distillate into an Erlenmeyer flask and add 2 ml ammonia buffer. Mix. Sample pH should be 10 ± 0.02 .

Add 2 ml aminoantipyrine and mix. Add 2 ml potassium ferricyanide and mix again. Allow 15 min for color development. Measure the absorbance of the sample at 510 nm relative to a reagent blank.

Method 1B: Solvent Extraction. Transfer 500 ml distillate to a 1- ℓ separatory funnel. Add 3 ml ammonia chloride solution and mix. Add 3 ml aminoantipyrine solution and mix. Add 3 ml potassium ferricyanide and mix again. Allow color to develop 3 to 5 min.

Add 25 ml chloroform and shake vigorously for 30 sec. Allow layers to separate and shake again for 30 sec.

Draw off the chloroform layer through filter paper or a cotton pledget. Measure the absorbance of the sample at 460 nm relative to a reagent blank.

Calculations

Prepare a standard curve based on the absorbance of the standard phenol solutions. Determine the phenol concentrations in the distillate by comparing sample absorbance with the standard curve.

$$\text{Phenol } \mu\text{g}/\text{kg (wet weight)} = \frac{(A)(B)(1000)}{E}$$

$$\text{Phenol } \mu\text{g/kg (dry weight)} = \frac{(A)(B)(1000)}{(g)(\% S)}$$

where

A = phenol concentration in distillate, $\mu\text{g}/\ell$

B = total volume of distillate, ℓ (0.5 ℓ as written)

g = wet weight of sediment, g

% S = percent solids in sediment (expressed as a decimal fraction)

Method 2: MBTH Colorimetric

Apparatus

Distillation apparatus, all glass, with 1- ℓ distillation flask

Separatory funnels, 1 ℓ , with Teflon stopcocks

Spectrophotometer, with 490-nm filter

Reagents

Copper sulfate solution: dissolve 100 g $\text{CuSO}_4 \cdot 5\text{H}_2\text{O}$ in distilled water and dilute to 1 ℓ .

Sulfuric acid, 1 N: add 28 ml of conc. H_2SO_4 to 900 ml of distilled water, mix, and dilute to 1 ℓ .

MBTH solution, 0.05 percent: dissolve 0.1 g of 3-methyl-2-benzothiazolinone hydrazone hydrochloride in 200 ml of distilled water.

Ceric ammonium sulfate solution: add 2.0 g of $\text{Ce}(\text{SO}_4)_2 \cdot 2(\text{NH}_4)_2\text{SO}_4 \cdot 2\text{H}_2\text{O}$ and 2.0 ml of conc. H_2SO_4 to 150 ml of distilled water. After the solid has dissolved, dilute to 200 ml with distilled water.

Buffer solution: dissolve in the following order: 8 g of sodium hydroxide, 2 g EDTA (disodium salt) and 8 g boric acid in 200 ml of distilled water. Dilute to 250 ml with distilled water.

Working buffer solution: make a working solution by mixing an appropriate volume of buffer solution with an equal volume of ethanol.

Chloroform.

Stock phenol: dissolve 1.00 g phenol in 500 ml of distilled water and dilute to 1 ℓ . Add 1 g CuSO_4 and 0.5 ml conc. H_2SO_4 as preservative. 1.0 ml = 1.0 mg phenol.

Standard phenol solution A: dilute 10.0 ml of stock phenol solution to 1 ℓ . 1.0 ml = 0.01 mg phenol.

Standard phenol solution B: dilute 100 ml of standard phenol solution A to 1 ℓ with distilled water. 1.0 ml = 0.001 mg phenol.

Procedure

Weigh out a 10- to 50-g aliquot of blended, wet sediment and transfer to a 1-l distillation flask. The sediment sample should not contain more than 50 µg phenol. Add 550 ml distilled water.

Add 5 ml 10 percent copper sulfate solution and 5 ml phosphoric acid solution. The pH of the sediment suspension should be approximately 4.

NOTE: This step can be omitted if the sample was previously preserved.

Add a few boiling stones and distill over 500 ml of sample. The phenol concentration can be quantified using direct colorimetry if the concentration is above 50 µg/l (Method 2A) or by solvent extraction if the concentration is less than 50 µg/l (Method 2B).

Method 2A: Direct Colorimetry. To 100 ml of distillate or a smaller aliquot diluted to 100 ml, add 4 ml MBTH solution and mix.

Allow 5 min for the MBTH-phenol coupling reaction and add 2.5 ml ceric ammonium sulfate solution. Mix the solution.

Five minutes later, add 7 ml working buffer solution. Wait 15 min for color development and measure the sample absorbance at 520 nm relative to a reagent blank. The color is stable for 4 hr.

Method 2B: Solvent Extraction. Transfer the 500-ml distillate to a 1-l separatory funnel. Add 4 ml MBTH solution, mix, and allow 5 min for the phenol-MBTH coupling reaction.

Add 2.5 ml ceric ammonium sulfate and again wait 5 min. Add 7 ml working buffer solution and allow 15 min for color development.

Add 25 ml chloroform to the separatory funnel and shake vigorously for 30 sec. Let the layers separate and again shake for 30 sec. Drain the chloroform layer through filter paper. Measure the absorbance of the sample at 490 nm relative to a reagent blank.

Calculations

Prepare a standard curve by plotting the absorbance of the phenol standards against known concentrations. Compare sample absorbance measurements to the standard curve to determine phenol concentrations in the distillates. Calculate the sediment phenol concentrations:

$$\text{Phenol } \mu\text{g/kg (wet weight)} = \frac{(A)(B)(1000)}{(g)}$$

$$\text{Phenol } \mu\text{g/kg (dry weight)} = \frac{(A)(B)(1000)}{(g)(\% S)}$$

where

A = distillate phenol concentration, $\mu\text{g}/\ell$

B = volume of distillate, ℓ

g = wet weight of sediment, g

% S = percent solids in sediment (expressed as a decimal fraction)

References

1. Environmental Protection Agency. "Methods for Chemical Analysis of Water and Wastes." Environmental Monitoring and Support Laboratory, EPA; Cincinnati, Ohio (1979).
2. American Public Health Association. Standard Methods for the Examination of Water and Wastewater Including Bottom Sediments and Sludges. 14th Edition. APHA; New York, New York. 1193 p. (1976).
3. American Society for Testing Materials. Book of ASTM Standards, Part 31. Water. American Society for Testing Materials; Philadelphia, Pennsylvania (1976).
4. U. S. Department of the Interior. "Chemistry Laboratory Manual for Bottom Sediments." Great Lakes Region Committee on Analytical Methods, U. S. Department of the Interior; Chicago, Illinois. 96 p. (1968).

MISCELLANEOUS ANALYSIS

Chlorine Demand
Biochemical Oxygen Demand
Chemical Oxygen Demand
Sediment Oxygen Demand

CHLORINE DEMAND

The chlorine demand of a sample is the difference between the amount of chlorine applied and the amount of free, combined, or total available chlorine remaining at the end of the contact period. The demand is caused by substances that can be oxidized by, or react with, chlorine. Examples of specific compounds that will be included in the chlorine demand are reduced inorganic ions such as ferrous iron, manganous manganese, nitrite, sulfide and sulfite, ammonia and amino compounds, and aromatic compounds such as phenol.^{1*}

The original purpose of a chlorine demand test was to determine the amount of chlorine that had to be added to a water source to achieve a free chlorine residual for disinfection purposes. This was accomplished by adding a known quantity of chlorine to the sample and observing residual chlorine concentrations over time. If residual chlorine goes to zero during the test, the test should be terminated at that point in time or rerun at a higher initial chlorine concentration. Since the chlorine demand will vary with the initial chlorine dose, pH, temperature, and time of contact, all test conditions should be recorded.

Sample Handling and Storage

Many of the compounds that contribute to the chlorine demand of a sample can also be oxidized by oxygen. Therefore, sample processing should begin as soon as possible after collection using either total water samples (W1), filtered water samples (W2, S1A), or field moist sediment samples (S1D). The processes of air drying and freezing/thawing can alter chlorine demand of the samples and are not recommended. This information is summarized in Figure 3-44.

* References for this section are found on page 3-372.

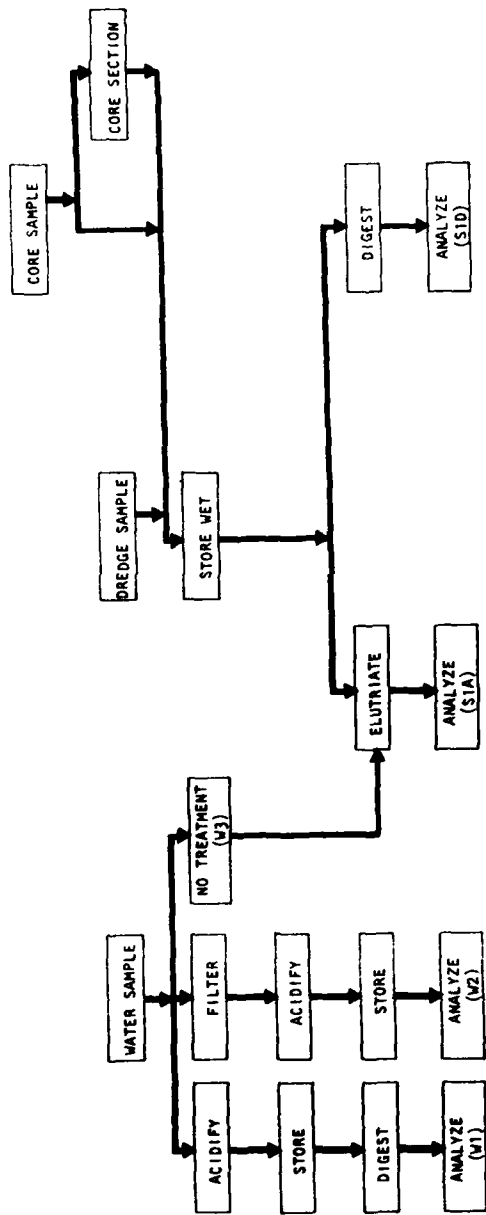

SAMPLE DESIGNATION	W1	W2	W3	S1A	S1B	S1C	S1D	S2	S3
PURPOSE	Total Water Conc.	Soluble Water Conc.	Used In Elutriate	Mobile Conc.			Total Sediment Conc.		
CONTAINER	G,P	G,P	G,P	G,P			G,P		
SAMPLE TREATMENT	None	Filter	None	None			None		
PRESERVATIVE	4°C	4°C	4°C	4°C (Minimize Air Contact. Keep Field Moist.)			4°C		
STORAGE TIME	24 hr	24 hr	<1 w	24 hr			<1 w		
DIGESTION SOLUTION									
SAMPLE VOLUME OR WEIGHT	250 ml	250 ml	-	250 ml			2 g		

Figure 3-44. Handling and storage of samples for chlorine demand analysis

Procedures for Water Samples (W1, W2, S1A)¹

Apparatus

Stirrer and magnetic stirring bar

500-ml Erlenmeyer flasks

50-ml buret

Reagents

Standard chlorine solution: prepare by bubbling chlorine gas through distilled water or by diluting household bleach, a hypochlorite solution, to a suitable concentration. The concentration of the chlorine solution should be sufficiently strong that the volume of the sample will not be increased by more than 5 percent after the addition of the chlorine solution. The useful life of the solution can be extended by storage in a dark or brown glass-stoppered bottle. However, a chlorine solution is unstable and must be standardized each time it is used.

In order to standardize the chlorine solution, place 2 ml glacial acetic acid and 25 ml distilled water in a flask. Add approximately 1 g KI. Pipet a convenient volume of chlorine solution into the flask. Titrate with a 0.025 N sodium thiosulfate solution to a pale yellow color. Add 1 to 2 ml of starch indicator solution and continue the thiosulfate titration to the disappearance of the blue color. A blank consisting of 2 ml of glacial acetic acid, 25 ml of distilled water, and 1 g KI should also be titrated to correct for any chlorine demand or residual chlorine in the water or reagents.

It will be necessary to conduct a blank titration to correct the results for reagent impurities such as: (a) the free iodine or iodate in the potassium iodide that liberates extra iodine; or (b) the traces of reducing agents that might reduce some of the iodine liberated. Take a volume of distilled water corresponding to the sample used for titration during the standardization procedure, add 2 ml acetic acid, 1 g KI, and 1 ml starch solution. Since the blank may be either positive or negative, it will be necessary to perform either blank titration A or B, whichever applies:

- a. Blank titration A: if a blue color develops, titrate with 0.01 N or 0.025 N sodium thiosulfate to the disappearance of the color and record results.
- b. Blank titration B: if no blue color occurs, titrate with 0.0282 N iodine solution until a blue color appears. Back-titrate with 0.01 N or 0.025 N sodium thiosulfate, and record the difference as titration B.

Before calculating the chlorine consumed, subtract blank titration A from the sample titration, or, if necessary, add the net equivalent value of blank titration B.

Glacial acetic acid, CH_3COOH .

Potassium iodide crystals, KI.

Standard sodium thiosulfate, 0.1 N: dissolve 25 g $\text{Na}_2\text{S}_2\text{O}_3 \cdot 5\text{H}_2\text{O}$ in 1 l freshly boiled distilled water and standardize the solution against potassium biniodate or potassium dichromate after at least 2 weeks storage. Use boiled distilled water and add a few milliliters CHCl_3 to minimize bacterial decomposition of the thiosulfate solution.

Standardize the 0.1 N sodium thiosulfate titrant using either (a) the biniodate method or (b) the dichromate method:

- a. Biniodate method: dissolve 3.249 g primary standard quality anhydrous potassium biniodate, $\text{KH}(\text{IO}_3)_2$, in distilled water and dilute to 1 l to yield a 0.1000 N solution. Store in a glass-stoppered bottle.

To 80 ml distilled water, add, with constant stirring, 1 ml conc. H_2SO_4 , 10 ml 0.100 N $\text{KH}(\text{IO}_3)_2$, and 1 g KI. Titrate immediately with sodium thiosulfate titrant until the yellow color of the liberated iodine is almost discharged. Add 1 ml starch indicator solution and continue the titration until the blue color disappears.

- b. Dichromate method: dissolve 4.904 g primary standard quality anhydrous potassium dichromate, $\text{K}_2\text{Cr}_2\text{O}_7$, in distilled water and dilute to 1000 ml to yield a 0.100 N solution. Store in a glass-stoppered bottle.

Proceed as in the biniodate method, with the following exceptions: substitute 10.00 ml 0.1000 N $\text{K}_2\text{Cr}_2\text{O}_7$ for the $\text{KH}(\text{IO}_3)_2$ and let the reaction mixture stand for 6 min in the dark before titrating with the $\text{Na}_2\text{S}_2\text{O}_3$ titrant.

The normality of the thiosulfate titrant can be calculated as:

Normality $\text{Na}_2\text{S}_2\text{O}_3$ =

$$\frac{(\text{Volume oxidizing agent})(\text{Normality oxidizing agent})}{(\text{Volume } \text{Na}_2\text{S}_2\text{O}_3 \text{ consumed})}$$

Dilute sodium thiosulfate titrant, 0.01 N or 0.025 N: dilute 100 ml (0.01 N) or 250 ml (0.025 N) of 0.1 N sodium thiosulfate to 1 l with distilled water. To improve the stability of these titrants, the standard thiosulfate should be aged several weeks and the distilled water should be fresh.

Standardize this solution daily in accordance with the directions given above, using 0.01 N or 0.025 N $\text{KH}(\text{IO}_3)_2$ or $\text{K}_2\text{Cr}_2\text{O}_7$. (To speed up operations where many samples must be titrated, use an automatic buret of a type in which rubber does not come in contact with the solution.)

Standard sodium thiosulfate titrants, 0.0100 N and 0.0250 N are equivalent, respectively, to 354.5 μg and 886.3 μg available Cl/1.00 ml.

Starch indicator solution: to 5 g starch (potato, arrowroot, or soluble), add a little cold water and grind in a mortar to a thin paste. Pour into 1 ℓ of boiling distilled water, stir, and let settle overnight. Use the clear supernate. Preserve with 1.25 g salicylic acid, 4 g zinc chloride, or a combination of 4 g sodium propionate and 2 g sodium azide/ℓ starch solution. Some commercial starch substitutes are satisfactory.

Standard iodine solution, 0.1 N: dissolve 40 g KI in 25 ml distilled water, add 13 g resublimed iodine, and stir until dissolved. Transfer to a 1-ℓ volumetric flask and dilute to the mark.

Standardization: accurately measure 40 to 50 ml 0.1 N arsenite solution into a flask and titrate with the 0.1 N iodine solution, using starch solution as an indicator. To obtain accurate results, it is absolutely necessary that the solution be saturated with CO₂ at the end of the titration. A current of CO₂ may be passed through the solution for a few minutes just before the end point is reached or a few drops of HCl may be added to liberate sufficient CO₂ to saturate the solution.

Standard iodine titrant, 0.0282 N: dissolve 25 g KI in a small volume of distilled water in a 1-ℓ volumetric flask. Add 282 ml 0.1 N iodine solution and dilute to 1 ℓ. Standardize this solution daily with arsenite solution. Store in amber bottles or in the dark. Protect the solution from direct sunlight at all times. Do not allow the solution to contact rubber.

Procedure

Add 250 ml of a water sample to a 500-ml brown glass-stoppered bottle or a 500-ml Erlenmeyer flask. A separate blank consisting of 250 ml of chlorine-free water should be prepared and treated as a sample.

Pipet a standardized chlorine solution into the water sample with rapid stirring to ensure instantaneous mixing. The chlorine solution should be standardized on the day of use and of sufficient strength so that a sample size of 15 ml or less can be used to minimize any dilution effects.

The chlorinated sample should preferably be kept in the dark to avoid photodecomposition of the added chlorine. Continue to stir the solution for 15 min.

After 15 min, withdraw a 25-ml subsample. Acidify the subsample to pH 3 to 4 with the addition of 5 ml of glacial acetic acid and add approximately 1 g KI. Mix the sample and titrate with standard sodium thiosulfate to a pale yellow color. Add 1 to 2 ml starch solution and continue titrating to the disappearance of the

blue color.

Record the volume of the standard thiosulfate required to titrate the sample and the blank.

Repeat the subsampling and titration at convenient time intervals such as 30 min, 45 min, and 60 min.

Continue the test until the residual chlorine concentration has stabilized. If the residual chlorine concentration drops to zero, the test should be terminated at that point or the test should be repeated with a higher initial chlorine concentration.

Calculations

The chlorine demand of the sample is the difference between the residual chlorine concentration in the blank and the residual chlorine concentration in the sample. The chlorine consumed at a particular sampling interval can be calculated as:

$$CC = \frac{(V_B - V_S)(N)(35.45 \text{ mg/meq})(V_0)}{(V_1)}$$

where

CC = chlorine consumed, mg

V_B = volume $S_2O_3^{2-}$ to titrate blank, ml

V_S = volume $S_2O_3^{2-}$ to titrate sample, ml

N = normality of standard $S_2O_3^{2-}$, meq/l

35.45 = equivalent weight of chlorine, mg/meq

V_0 = volume of sample initially chlorinated, ml

V_1 = volume of subsample titrated, ml

The chlorine demand of the sample can be calculated as:

$$CD \text{ mg/l} = \frac{CC}{V}$$

where

CD = chlorine demand, mg/l

CC = chlorine consumed at a specified time, mg

V = volume of sample chlorinated, l

Procedures for Sediment Samples (SID)²

Apparatus

Stirrer and magnetic stirring bar

500-ml Erlenmeyer flasks

50-ml buret

Reagents

Standard chlorine solution: prepare by bubbling chlorine gas through distilled water or by diluting household bleach, a hypochlorite solution, to a suitable concentration. The concentration of the chlorine solution should be sufficiently strong so that the volume of the sample will not be increased by more than 5 percent after the addition of the chlorine solution. The useful life of the solution can be extended by storage in a dark or brown glass-stoppered bottle. However, a chlorine solution is unstable and must be standardized each time it is used.

In order to standardize the chlorine solution, place 2 ml glacial acetic acid and 25 ml distilled water in a flask. Add approximately 1 g KI. Pipet a convenient volume of chlorine solution into the flask. Titrate with a 0.025 N sodium thiosulfate solution to a pale yellow color. Add 1 to 2 ml of starch indicator solution and continue the thiosulfate titration to the disappearance of the blue color. A blank consisting of 2 ml of glacial acetic acid, 25 ml of distilled water, and 1 g KI should also be titrated to correct for any chlorine demand or residual chlorine in the water or reagents.

It will be necessary to conduct a blank titration to correct the results for reagent impurities such as: (a) the free iodine or iodate in the potassium iodide that liberates extra iodine or (b) the traces of reducing agents that might reduce some of the iodine liberated. Take a volume of distilled water corresponding to the sample used for titration during the standardization procedure, add 2 ml acetic acid, 1 g KI, and 1 ml starch solution. Since the blank may be either positive or negative, it will be necessary to perform either (a) blank titration A or (b) blank titration B, whichever applies:

- a. Blank titration A: if a blue color develops, titrate with 0.01 N or 0.025 N sodium thiosulfate to the disappearance of the color and record results.
- b. Blank titration B: if no blue color occurs, titrate with 0.0282 N iodine solution until a blue color appears. Back-titrate with 0.01 N or 0.025 N sodium thiosulfate and record the difference as titration B.

Before calculating the chlorine consumed, subtract blank titration A from the sample titration, or, if necessary, add the net equivalent value of blank titration B.

Glacial acetic acid, CH_3COOH .

Potassium iodide crystals, KI.

Standard sodium thiosulfate, 0.1 N: dissolve 25 g $\text{Na}_2\text{S}_2\text{O}_3 \cdot 5\text{H}_2\text{O}$ in 1 l freshly boiled distilled water and standardize the solution against potassium biniodate or potassium dichromate after at least 2 weeks storage. Use boiled distilled water and add a few milliliters CHCl_3 to minimize bacterial decomposition of the thiosulfate solution.

Standardize the 0.1 N sodium thiosulfate titrant using either (a) the biniodate method or (b) the dichromate method:

a. Biniodate method: dissolve 3.249 g primary standard quality anhydrous potassium biniodate, $\text{KH}(\text{IO}_3)_2$, in distilled water and dilute to 1 l to yield a 0.1000 N solution. Store in a glass-stoppered bottle.

To 80 ml distilled water, add, with constant stirring, 1 ml conc. H_2SO_4 , 10 ml 0.100 N $\text{KH}(\text{IO}_3)_2$, and 1 g KI. Titrate immediately with sodium thiosulfate titrant until the yellow color of the liberated iodine is almost discharged. Add 1 ml starch indicator solution and continue the titration until the blue color disappears.

b. Dichromate method: dissolve 4.904 g primary standard quality anhydrous potassium dichromate, $\text{K}_2\text{Cr}_2\text{O}_7$, in distilled water and dilute to 1000 ml to yield a 0.1000 N solution. Store in a glass-stoppered bottle.

Proceed as in the biniodate method, with the following exceptions: substitute 10.00 ml 0.1000 N $\text{K}_2\text{Cr}_2\text{O}_7$ for the $\text{KH}(\text{IO}_3)_2$ and let the reaction mixture stand for 6 min in the dark before titrating with the $\text{Na}_2\text{S}_2\text{O}_3$ titrant.

The normality of the thiosulfate titrant can be calculated as:

$$\text{Normality } \text{Na}_2\text{S}_2\text{O}_3 = \frac{(\text{Volume oxidizing agent})(\text{Normality oxidizing agent})}{(\text{Volume } \text{Na}_2\text{S}_2\text{O}_3 \text{ consumed})}$$

Dilute sodium thiosulfate titrant, 0.01 N or 0.025 N: dilute 100 ml (0.01 N) or 250 ml (0.025 N) of 0.1 N sodium thiosulfate to 1 l with distilled water. To improve the stability of these titrants, the standard thiosulfate should be aged several weeks and the distilled water should be fresh.

Standardize this solution daily in accordance with the directions given above, using 0.01 N or 0.025 N $\text{KH}(\text{IO}_3)_2$ or $\text{K}_2\text{Cr}_2\text{O}_7$. (To speed up operations where many samples must be titrated, use an automatic buret of a type in which rubber does not come in contact with the solution.)

Standard sodium thiosulfate titrants, 0.0100 N and 0.0250 N, are equivalent, respectively, to 354.5 μg and 886.3 μg available Cl/1.00 ml.

Starch indicator solution: to 5 g starch (potato, arrowroot, or soluble), add a little cold water and grind in a mortar to a thin paste. Pour into 1 l of boiling distilled water, stir, and let settle overnight. Use the clear supernate. Preserve with 1.25 g salicylic acid, 4 g zinc chloride, or a combination of 4 g sodium propionate and 2 g sodium azide/l starch solution. Some commercial starch substitutes are satisfactory.

Standard iodine solution, 0.1 N: dissolve 40 g KI in 25 ml distilled water, add 13 g resublimed iodine, and stir until dissolved. Transfer to a 1-l volumetric flask and dilute to the mark.

Standardization: accurately measure 40 to 50 ml 0.1 N arsenite solution into a flask and titrate with the 0.1 N iodine solution, using starch solution as an indicator. To obtain accurate results, it is absolutely necessary that the solution be saturated with CO₂ at the end of the titration. A current of CO₂ may be passed through the solution for a few minutes just before the end point is reached; or a few drops of HCl may be added to liberate sufficient CO₂ to saturate the solution.

Standard iodine titrant, 0.0222 N: dissolve 25 g KI in a small volume of distilled water in a 1-l volumetric flask. Add 282 ml 0.1 N iodine solution and dilute to 1 l. Standardize this solution daily with arsenite solution. Store in amber bottles or in the dark. Protect the solution from direct sunlight at all times. Do not allow the solution to contact rubber.

Procedure

Add 250 ml of chlorine-free water to a 500-ml brown glass-stoppered bottle or a 500-ml Erlenmeyer flask. Transfer 1 to 2 g of well-mixed, wet sediment (SID) to the bottle. A separate blank consisting of 250 ml chlorine-free water should be prepared and treated as a sample.

Pipet a standardized chlorine solution into the sediment suspension with rapid stirring to ensure instantaneous mixing. The chlorine solution should be standardized on the day of use and of sufficient strength so that a sample size of 15 ml or less can be used. This will minimize any dilution effects.

The chlorinated sample should preferably be kept in the dark to avoid photodecomposition of the added chlorine. Continue stirring the sediment suspension for 15 min.

After 15 min, withdraw a 25-ml subsample. Acidify the sample to pH 3 to 4 with the addition of 5 ml glacial acetic acid. Add approximately 1 g KI. Mix the sample and titrate with standard iodine solution to a pale yellow color. Add 1 ml starch solution

and continue titrating to the disappearance of the blue color. Starch may have to be added immediately to the sediment suspension if the yellow iodine color is not visible due to turbidity.

Record the volume of thiosulfate required to titrate the sample and the blank.

Repeat the subsampling and titrations at convenient time intervals such as 30 min, 45 min, and 60 min.

Continue the test until the residual chlorine concentration has stabilized. If the residual chlorine concentration drops to zero, the test should be terminated at that time or the test should be repeated using a higher initial chlorine concentration.

Calculations

The amount of chlorine consumed at a specified sampling interval can be calculated as:

$$CC = \frac{(V_B - V_S)(N)(35.45 \text{ mg/meq})(V_0)}{(V_1)}$$

where

CC = chlorine consumed, mg

V_B = volume thiosulfate to titrate blank, ml

V_S = volume thiosulfate to titrate sample, ml

N = normality of thiosulfate, meq/l

35.45 = equivalent weight of chlorine, mg/meq

V_0 = volume of distilled water in sample, ml

V_1 = volume of subsample titrated, ml

The chlorine demand of the sediment is calculated as:

$$CD \text{ mg/kg (wet weight)} = \frac{(CC)(1000)}{g}$$

$$CD \text{ mg/kg (dry weight)} = \frac{(CC)(1000)}{(g)(\% S)}$$

where

CD = chlorine demand, mg/kg

CC = chlorine consumed at a specified time, mg

g = wet weight of sediment sample chlorinated, g

% S = percent solids in sediment sample (expressed as a decimal fraction)

References

1. American Public Health Association. Standard Methods for the Examination of Water and Wastewater Including Bottom Sediments and Sludges. 14th Edition. APHA; New York, New York. 1193 p. (1975).
2. Great Lakes Region Committee on Analytical Methods. "Chemistry Laboratory Manual for Bottom Sediments." U. S. Department of the Interior, Great Lakes Basin; Chicago, Illinois. 96 p. (1968).

BIOCHEMICAL OXYGEN DEMAND

The biochemical oxygen demand (BOD) test is an empirical bioassay type procedure that measures the dissolved oxygen (DO) consumed by microbial organisms while assimilating and oxidizing the organic matter present. The procedure consists of measuring the change in oxygen concentration in a sample during a 5-day period at 20°C and in the dark. Although it is generally realized that 20 days or longer may be required to completely stabilize the organic material in an environmental sample, the 5-day period has been accepted as standard because of practical considerations and the fact that a large percentage of the ultimate demand is satisfied in the first 5 days.

Three methods have been used to measure the BOD of a sample. The selection between these methods depends on the amount of oxygen consumed during organic stabilization as indicated below:

- a. Direct method: used with samples whose 5-day BOD is determined by measuring the dissolved oxygen content of the water before and after a standard incubation period of 5 days at 20°C. Samples are aerated at the start of the test to raise dissolved oxygen concentrations to near saturation. The change in oxygen is based on the microbial population of the sample and additional test organisms are not added to the sample.
- b. Unseeded dilution method: used with waters having BOD values greater than 7 mg/l. Sample aliquots are diluted using water saturated with oxygen (dilution water). The dissolved oxygen concentration is determined immediately after dilution and after 5 days incubation at 20°C.
- c. Seeded dilution method: used with samples having low BOD values. When the microbial population of the sample is low or potentially toxic conditions exist in the sample, a mixed group of organisms, commonly called a seed, is added to the sample. Oxygen concentrations are then determined on the initial sample and after incubating for 5 days at 20°C.

Sample Handling and Storage

The BOD test can be performed with either water or sediment

samples. In either case, the sample should be protected from contact with atmospheric oxygen, and the analysis should be initiated within 4 to 6 hr of collection. This requires that wet sediments should be used and that both sediment and water samples to be analyzed for BOD be shipped and stored in airtight containers to minimize oxidation (Figure 3-45).

There is no recommended preservative at this time other than refrigeration at 4°C and a short holding time.

Procedures for Water Samples (W1, W2, SLA)^{1,2*}

Apparatus

Incubation bottles, 300-ml bottles with ground-glass stoppers

Incubator, thermostatically controlled at 20°C ± 1°C: all light should be excluded to prevent photosynthetic production of dissolved oxygen by algae in the sample

Graduated cylinders, 1 l or 2 l

Reagents

Distilled water: water used for solutions and for preparation of the dilution water must be of highest quality, distilled from a block tin or all-glass still, contain less than 0.01 mg/l copper, and be free of chlorine, chloramines, caustic alkalinity, organic material, or acids.

Phosphate buffer solution: dissolve 8.5 g potassium dihydrogen phosphate, KH_2PO_4 ; 21.75 g dipotassium hydrogen phosphate, K_2HPO_4 ; 33.4 g disodium hydrogen phosphate heptahydrate, $\text{Na}_2\text{HPO}_4 \cdot 7\text{H}_2\text{O}$; and 1.7 g ammonium chloride, NH_4Cl , in about 500 ml distilled water and dilute to 1 l. The pH of this buffer should be 7.2 without further adjustment. If dilution water is to be stored in the incubator, the phosphate buffer should be added just prior to using the dilution water.

Magnesium sulfate solution: dissolve 22.5 g magnesium sulfate, $\text{MgSO}_4 \cdot 7\text{H}_2\text{O}$, in distilled water and dilute to 1 l.

Calcium chloride solution: dissolve 27.5 g anhydrous calcium chloride CaCl_2 , in distilled water and dilute to 1 l.

Ferric chloride solution: dissolve 0.25 g ferric chloride, $\text{FeCl}_3 \cdot 6\text{H}_2\text{O}$, in distilled water and dilute to 1 l.

Acid and alkali solutions, 1 N: for neutralization of waste samples which are either caustic or acidic.

* References for this section are found on page 3-384.

Figure 3-45. Handling and storage of samples for biological oxygen demand analysis

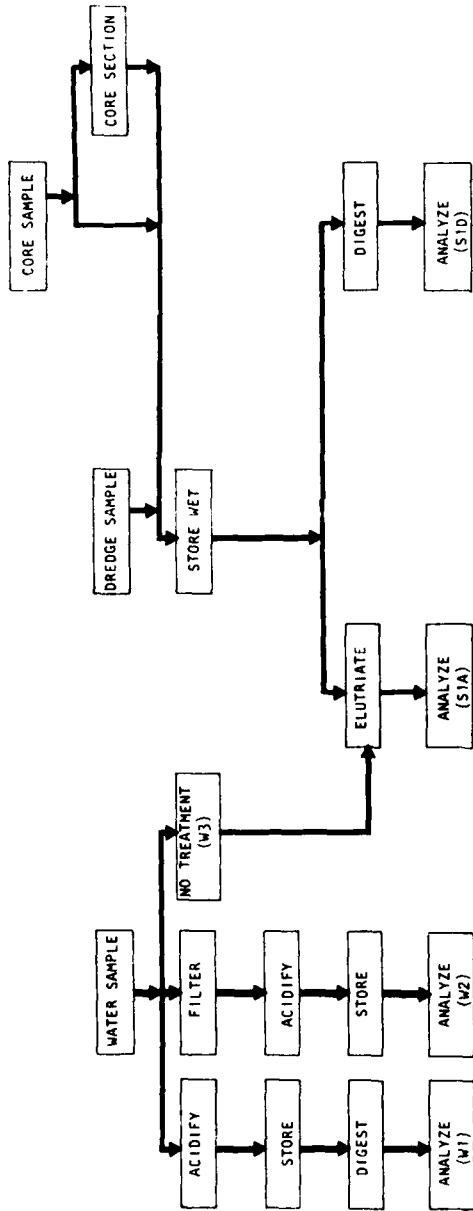

SAMPLE DESIGNATION	W1	W2	W3	S1A	S1B	S1C	S1D	S2	S3
PURPOSE	Total Water Conc.	Soluble Water Conc.	Used in Elutriate	Mobile Conc.			Total Sediment Conc.		
CONTAINER	G,P	G,P	G,P	G,P			G,P		
SAMPLE TREATMENT	None	Filter	None	None			None		
PRESERVATIVE	4°C	4°C	None	4°C (Minimize Air Contact. Keep Field Moist.)			4°C		
STORAGE TIME	6 hr	6 hr	<1 w	<1 w			<1 w		
DIGESTION SOLUTION									
SAMPLE VOLUME OR WEIGHT	0.3-12	0.3-12	-	0.3-12			5 g		

Sodium sulfite solution, 0.025 N: dissolve 1.575 g anhydrous sodium sulfite, Na_2SO_3 , in 1 l distilled water. This solution is not stable and should be prepared daily.

Seeding material: satisfactory seed may sometimes be obtained by using the supernatant liquor from domestic sewage which has been stored at 20°C for 24 to 36 hr. Refer to ASTM³ for a more detailed explanation of seeding material.

Dilution water: the distilled water used should have been stored in cotton-plugged bottles for a sufficient length of time to become saturated with DO. The water should be aerated by shaking a partially filled bottle or using a supply of clean compressed air. Situations may be encountered where it is desired to use stabilized river water to check stream performance with laboratory procedure. The distilled water used should be as near as possible to 20°C and of the highest purity. Place the desired volume of distilled water in a suitable bottle and add 1 ml each of phosphate buffer, magnesium sulfate, calcium chloride, and ferric chloride solutions for each liter of water.

Seeding: if necessary, the dilution water is seeded using the seed found to be the most satisfactory for the particular material under study. Only past experience can determine the actual amount of seed to be added per liter. Seeded dilution water should be used the same day it is prepared.

Sample pretreatment

Samples containing acidity or caustic alkalinity are neutralized to approximately pH 7 with H_2SO_4 (1 N) or NaOH (1 N) using a pH meter.

Chlorine residuals, if present in a sample, may dissipate after 1 to 2 hr. If chlorine residuals do not dissipate on standing, the neutralized sample must be treated with 0.025 N sodium sulfite solution. The appropriate quantity of sodium sulfite solution is determined on a 100- to 1000-ml portion of the sample by adding 10 ml 1 + 1 acetic acid or 1 + 50 H_2SO_4 , followed by 10 ml potassium iodide solution (10 g in 100 ml) and titrating with 0.025 N sodium sulfite solution to the starch-iodide endpoint. Add to a volume of sample the quantity of sodium sulfite solution determined by the above test; mix; and after 10 to 20 min, test sample aliquots for residual chlorine to check the treatment.

Samples supersaturated with oxygen must be reduced to saturation (9.17 mg/l at 20°C) by aerating with compressed air or by vigorous shaking of the sample container.

The sample pretreatment steps outlined only apply to water samples. It is expected that these sample preparation techniques will be required seldom, if ever, with sediment samples.

Procedure

Direct method for water. Fill two BOD bottles with the W1, W2, or S1A sample. Be sure that no air bubbles are entrapped and that the bottles are filled to overflowing when the stoppers are inserted.

Determine the dissolved oxygen concentration in one of the bottles. Record the value as initial DO.

Allow the other bottle to incubate for 5 days in the dark at 20°C and then determine the dissolved oxygen content. Record the value as final DO.

For the direct method, calculate the BOD as follows:

$$\text{BOD mg/l} = \text{Initial DO} - \text{Final DO}$$

Unseeded dilution method for water. Conduct any sample pretreatments that are necessary.

Fill a 1000- to 2000-ml capacity graduated cylinder approximately half full with dilution water. Add the volume of carefully mixed sample to produce the desired final dilution and dilute to the mark with dilution water. Mix well with a plunger-type mixing rod, taking precautions to avoid any entrainment of air. It is suggested that a minimum of three dilutions be prepared of each sample.

NOTE: Dilutions may also be prepared by directly pipetting known volumes of the sample into BOD bottles, providing the volume of the BOD bottle is known. However, this method should not be used if dilutions of 100:1 or more are required.

Determine the dissolved oxygen in one of the BOD bottles prepared above. Record as initial DO.

Incubate one of the remaining bottles for 15 min in the dark at 20°C and determine the oxygen content after the incubation for calculation of the immediate oxygen demand (IDOD). Record result as DO after 15 min.

Incubate the remaining bottle for 5 days and then determine the oxygen content. Record as final DO.

When the unseeded dilution method is used, the BOD of the sample is calculated as follows:

$$\text{BOD mg/l} = \frac{(I - F)(b)}{v}$$

where

I = dissolved oxygen concentration after 15 min, mg/l

F = dissolved oxygen concentration after 5 days, mg/l

b = volume of BOD bottle, ml

v = volume of sample BOD bottle, ml

Seeded dilution method. The procedure used in the unseeded dilution method is followed; but an additional step is necessary and that is to correct for the effect of the seed depletion of DO. Determine the oxygen depletion of the seed by setting up a separate series of seed dilutions (controls) and selecting those resulting in a 40 percent to 70 percent depletion in 5 days. One of these depletions is then used to calculate the correction due to the small amount of seed in the dilution water.

Fill a 1000- to 2000-ml capacity graduated cylinder approximately half full with seeded dilution water. Add the volume of carefully mixed sample to produce the desired final dilution and dilute to the mark with dilution water. Mix well with a plunger-type mixing rod, taking precautions to avoid any entrainment of air. It is suggested that a minimum of three dilutions be prepared of each sample.

NOTE: Preparation of diluted samples may also be accomplished by direct measurement of suitable amounts of sample into BOD bottles using a large-tipped volumetric pipette and then filling the bottles with dilution water. The volume of each bottle will have to be measured in order to calculate dilution factors needed to determine seed corrections. Dilutions greater than 100:1 must be performed in graduated cylinders.

Siphon, with continued mixing, the diluted sample to completely fill three bottles. One bottle is for the determination of initial dissolved oxygen concentration. The second bottle is incubated for 15 min and used to determine immediate dissolved oxygen demand (IDOD). The third sample is incubated for 5 days at 20°C and analyzed to determine oxygen consumption.

Calculations

The seed correction factor is calculated as:

$$C = \frac{(B)(x)}{y}$$

where

C = seed correction factor, mg/l

B = BOD of seed control, mg/l

x = percent seed in sample

y = percent seed in control

The BOD of the sample is calculated as:

$$\text{BOD mg/l} = \frac{(I - F - C)(b)}{v}$$

where

I = dissolved oxygen concentration after 15 min, mg/l

F = final dissolved oxygen concentration after 5 days, mg/l

C = seed correction factor

v = volume of sample in BOD bottle, ml

b = volume of BOD bottle, ml

The immediate dissolved oxygen demand (IDOD) is calculated as:

$$\text{IDOD mg/l} = \frac{(O - I)(b)}{v}$$

where

O = dissolved oxygen concentration at time zero, mg/l

I = dissolved oxygen concentration after 15 min, mg/l

v = volume of sample in BOD bottle, ml

b = volume of BOD bottle, ml

Procedures for Sediment Samples (SID)*

Apparatus

Incubation bottles, 300-ml capacity, with ground glass stoppers

Incubator, thermostatically controlled at $20^{\circ} \pm 1^{\circ}\text{C}$: all light should be excluded to prevent the photosynthetic production of dissolved oxygen by algae in the sample

Graduated cylinders, 1 l or 2 l

Reagents

Distilled water: free of copper, chlorine, chloramines, caustic alkalinity, acids, and organic material.

Phosphate buffer solution: dissolve 8.5 g potassium dihydrogen phosphate, KH_2PO_4 ; 21.75 g dipotassium hydrogen phosphate, K_2HPO_4 ; 33.4 g disodium hydrogen phosphate heptahydrate, $\text{Na}_2\text{HPO}_4 \cdot 7\text{H}_2\text{O}$; and 1.7 g ammonium chloride, NH_4Cl , in distilled water and dilute to 1 l. The pH of this buffer should be 7.2 without further adjustment. If dilution water is to be stored in the incubator, the phosphate buffer should be added just prior to using the dilution water.

Magnesium sulfate solution: dissolve 22.5 g magnesium sulfate, $\text{MgSO}_4 \cdot 7\text{H}_2\text{O}$, in distilled water and dilute to 1 l.

Calcium chloride solution: dissolve 27.5 g anhydrous calcium chloride, CaCl_2 , in distilled water and dilute to 1 l.

Ferric chloride solution: dissolve 0.25 g ferric chloride, $\text{FeCl}_3 \cdot 6\text{H}_2\text{O}$, in distilled water and dilute to 1 l.

Sodium sulfite solution, 0.025 N: dissolve 1.575 g anhydrous sodium sulfite, Na_2SO_3 , in 1 l distilled water. This solution is not stable and should be prepared daily.

Seeding material: satisfactory seed may sometimes be obtained by using the supernatant liquor from domestic sewage which has been stored at 20°C for 24 to 36 hr. Refer to ASTM³ for a more detailed explanation of seeding material.

Dilution water: store distilled water in cotton-plugged bottles for a sufficient length of time to become saturated with DO. The water should be aerated by shaking a partially filled bottle or using a supply of clean compressed air. Situations may be encountered where it is desired to use stabilized river water to check stream performance with laboratory procedure. The distilled water used should be as near as possible to 20°C and of high purity. Place the desired volume of distilled water in a suitable bottle and add 1 ml each of phosphate buffer, magnesium sulfate, calcium chloride, and ferric chloride for each liter of water.

Seeding: use the seed that has been found by practical experience to be the most satisfactory for the particular material

under study. Only past experience can determine the actual amount of seed to be added per liter but the amount should give an oxygen depletion of approximately 2 mg/l. The amount of seed required may vary with the source of the seed and will have to be established through experience. If the sample contains organic compounds not amenable to oxidation by domestic sewage seed, it may be necessary to use seed prepared from soil, an acclimated seed developed in the laboratory, or sediments collected below a particular waste discharge (preferably 2 to 5 miles below the point of discharge). Seeded dilution water should be used the same day it is prepared.

Procedure

Weigh an appropriate size S1D sediment sample directly into the BOD bottle (suggested weight of 0.5 to 5.0 g). Each sample should be prepared in replicate.

Fill each BOD bottle with dilution water and place the samples in the incubator. Ensure that air bubbles are not trapped in the BOD bottles. Prepare a blank consisting of dilution water in a separate BOD bottle. Make sure that there is a water seal in the neck of each sample bottle and blank when placed in the incubator. Replenish the water seals on all bottles each morning.

Determine the initial dissolved oxygen concentration of the sample using the azide modification of the iodometric method or a dissolved oxygen probe. This can best be accomplished by directly measuring the dissolved oxygen concentration in the dilution water. This method is recommended because sediment may cause a rapid consumption of oxygen, making it difficult to obtain a stable initial dissolved oxygen reading. (If a probe is used for oxygen measurement, the same sample can be used for immediate dissolved oxygen demand and biochemical oxygen demand.)

Incubate a blank (dilution water) and the sediment suspensions for 5 days at 20°C. Determine residual dissolved oxygen concentrations in the incubated samples using the analytical method of choice. The most reliable BOD determinations will occur in those samples with a residual DO of at least 2 mg/l and a DO depletion of at least 2 mg/l.

It may be desirable to incubate the dilution water as a check on its quality. In order to do this, fill two BOD bottles with unseeded dilution water. Stopper one bottle, fill the water seal,

and place in the incubator for 5 days. Analyze the second sample to determine initial dissolved oxygen concentration. Following the 5-day period, determine dissolved oxygen in the incubated sample. The oxygen depletion should not be more than 0.2 mg/l and preferably not more than 0.1 mg/l. If these values are exceeded, the quality of the dilution water or the treatment of samples (filling of water seals, etc.) should be considered suspect.

It is also recommended that the analyst routinely run pure organic compounds for which the BOD is known or determinable. This is necessary because the quality of the dilution water, the effectiveness of the seed, the technique of the analyst, and the presence of toxic substances can all influence BOD results. The use of known standards will indicate whether any of the identified factors are out of control.

Prepare a stock BOD standard solution by dissolving 0.150 g reagent grade glucose and 0.150 g reagent grade glutamic acid in 1 l of distilled water. The solids should be dried for 1 hr at 103°C prior to weighing.

Prepare a working BOD standard solution by diluting 20 ml of the stock solution to 1 l with seeded dilution water. Fill three BOD bottles and incubate at 20°C for 5 days. The resultant BOD of these samples should be 218 mg/l \pm 11 mg/l. Any appreciable deviation from these expected results raises questions on the quality of the dilution water, the viability or suitability of the seed material, or the analytical technique.

Interferences

Many synthetic organic components in industrial waste waters and sediments are not biodegradable without the seeding procedure because of either a toxic effect or a deficiency or absence of appropriate microorganisms.

Chlorine residuals must be removed prior to the test because residual chlorine may be toxic to the microbial population or may oxidize organic material.

Because waters and sediments that contain sulfide, sulfite, or ferrous ions create an immediate demand on the dissolved oxygen, it is necessary to distinguish this immediate dissolved oxygen demand

(IDOD) from the true BOD. The depletion of DO in a standard water dilution of the sample in 15 min has been arbitrarily selected as the IDOD.

Calculations

Immediate dissolved oxygen demand (IDOD) is calculated as follows:

$$\text{IDOD mg/kg (wet weight)} = \frac{(O - I)(b)}{g}$$

$$\text{IDOD mg/kg (dry weight)} = \frac{(O - I)(b)}{(g)(\% S)}$$

where

- O = dissolved oxygen concentration at time zero, mg/l
- I = dissolved oxygen concentration after 15 min, mg/l
- b = volume of BOD bottle, ml
- g = wet weight of sediment sample used, g
- % S = percent solids in sediment sample (expressed as a decimal fraction)

The sediment BOD is calculated as follows:

$$\text{BOD mg/kg (wet weight)} = \frac{(O - F)(b)}{g}$$

$$\text{BOD mg/kg (dry weight)} = \frac{(O - F)(b)}{(g)(\% S)}$$

where

- O = dissolved oxygen concentration at time zero, mg/l
- F = dissolved oxygen concentration after 5 days, mg/l
- b = volume of BOD bottle, ml
- g = wet weight of sediment sample used, g
- % S = percent solids in sediment sample (expressed as a decimal fraction)

AD-A105 788

STATE UNIV OF NEW YORK COLL AT BUFFALO GREAT LAKES LAB F/G 13/2 -
PROCEDURES FOR HANDLING AND CHEMICAL ANALYSIS OF SEDIMENT AND W--ETC(11)
MAY 81 R H PLUMB EPA-44-05-5720-10

UNCLASSIFIED

EPA/CE-R1-1

NL

6 of 6

of 20000



END
DATE
FILED
10 81
DTIC

References

1. American Public Health Association. Standard Methods for the Examination of Water and Wastewater Including Bottom Sediments and Sludges. 14th Edition. APHA; New York, New York. 1193 p. (1975).
2. Environment Canada. "Analytical Methods Manual." Inland Waters Directorate, Water Quality Branch; Ottawa, Ontario, Canada (1974).
3. American Society for Testing and Materials. Book of ASTM Standards. Part 31. Water. American Society for Testing and Materials; Philadelphia, Pennsylvania (1976).
4. Great Lakes Region Committee on Analytical Methods. "Chemistry Laboratory Manual for Bottom Sediments." U. S. Department of the Interior, Great Lakes Region; Chicago, Illinois. 96 p. (1968).

CHEMICAL OXYGEN DEMAND

The chemical oxygen demand (COD) test was devised as an alternate to the biochemical oxygen demand test for estimating organic matter. The procedure consists of digesting a sample with a strong oxidizing agent at elevated temperatures and reduced pH. The amount of oxidizing agent consumed during the test is expressed as an equivalent amount of oxygen. Since most organic compounds will be oxidized under conditions of the test, results are considered a measure of the amount of oxygen required to stabilize organic matter present in the sample.

The COD procedure can be used to characterize a sample. However, the user is cautioned that the method is not specific for organic matter. A number of inorganic substances that may be present in water samples, Fe^{+2} , Mn^{+2} , S^{-2} , NO_2^- , can increase the consumption of oxidizing agent during the test. As a consequence, a lack of correlation between COD results and other tests that measure organic carbon (BOD, TOC) has been reported. This problem will be amplified in sediment samples due to the reduced nature of most sediments and the higher concentration of reduced inorganic species such as Fe^{+2} , Mn^{+2} , and S^{-2} . It is recommended that COD results not be equated with organic matter in sediments.

Sample Handling and Storage

Information for the handling of COD samples is summarized in Figure 3-46. Water samples may be stored in either glass or plastic containers and preserved for up to 7 days with sulfuric acid. Sediment samples may also be stored in either glass or plastic containers. However, since there are no chemical preservative agents and sediment COD can be affected by air oxidation, it is suggested that only field moist sediment samples (SLD) be used for COD analysis.

Figure 3-46. Handling and storage of samples for chemical oxygen demand analysis

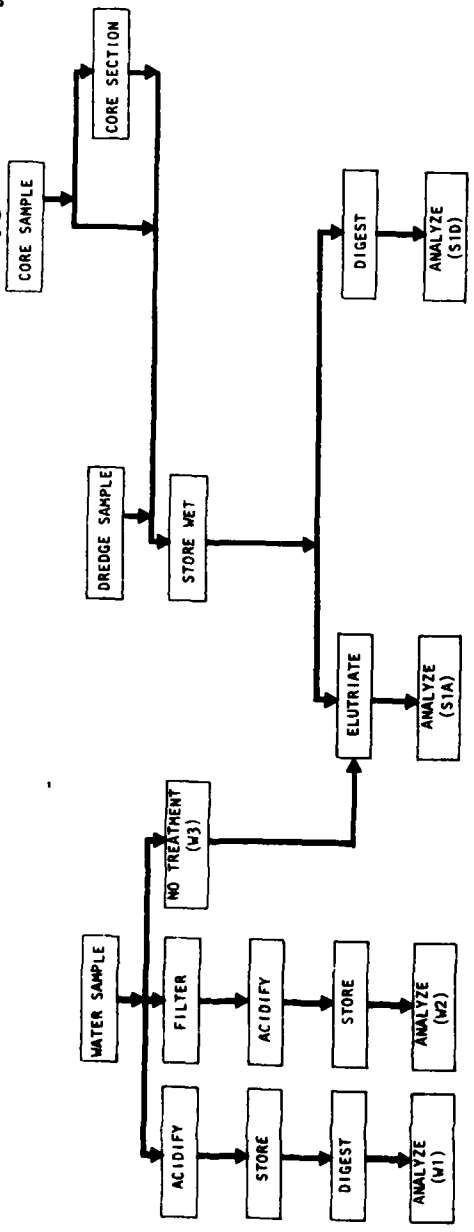

SAMPLE DESIGNATION	W1	W2	W3	S1A	S1B	S1C	S1D	S2	S3
PURPOSE	Total Water Conc.	Soluble Water Conc.	Used In Elutriate	Mobile Conc.			Total Sediment Conc.		
CONTAINER	G,P	G,P	G,P	G,P			G,P		
SAMPLE TREATMENT	None	Filter	None	None			None		
PRESERVATIVE	4°C H ₂ SO ₄ pH<2	4°C H ₂ SO ₄ pH<2	4°C	4°C (Minimize Air Contact. Keep Field Moist)			4°C		
STORAGE TIME	7 d	7 d	<1w	<1w			<1w		
DIGESTION SOLUTION									
SAMPLE VOLUME OR WEIGHT	20 ml	20 ml		20 ml					2 g

Procedures for Water Samples (W1, W2, S1A)^{1,2*}

Method 1: Low Level, 5 to 50 mg/l

Apparatus

Reflux apparatus: consisting of 250- or 500-ml Erlenmeyer flasks with ground-glass 24/40 neck** and 300-mm jacket Liebig, West, or equivalent condenser† with 24/40 ground-glass joint

Hot plate: having sufficient power to produce 1.4 W/cm² (9 W/in.²) of heating surface, or equivalent, to ensure adequate refluxing of the sample

Reagents

Standard potassium dichromate solution, 0.250 N: dissolve 12.259 g potassium dichromate, K₂Cr₂O₇, primary standard grade, previously dried at 103°C for 2 hr, in distilled water and dilute to 1 l. To eliminate the interference of nitrites, sulphamic acid, in the amount of 10 mg for every 1 mg of nitrite N in the refluxing flask, may be added to the dichromate solution. Thus, 0.12 g/l sulphamic acid added to the dichromate solution will eliminate the interference of nitrites up to 6 mg/l in the sample.

Dilute potassium dichromate solution, 0.025 N: dilute 100 ml of standard potassium dichromate solution, 0.250 N, to 1 l with distilled water.

Sulfuric acid reagent: conc. H₂SO₄ containing 22 g silver nitrate, Ag₂SO₄, per 9-lb bottle (1 or 2 days required for dissolution).

Standard ferrous ammonium sulfate titrant, 0.25 N: dissolve 98 g ferrous ammonium sulfate, Fe(NH₄)₂(SO₄)₂ · 6H₂O, in distilled water. Add 20 ml of conc. H₂SO₄ (CAUTION!) and allow to cool. Titrate with the ferrous ammonium sulfate titrant, using 2 or 3 drops of ferroin indicator.

$$\text{Normality} = \frac{(\text{ml K}_2\text{Cr}_2\text{O}_7)(0.25)}{[\text{ml Fe}(\text{NH}_4)_2(\text{SO}_4)_2]}$$

Standard ferrous ammonium sulfate, 0.025 N: dilute 100 ml ferrous ammonium sulfate, 0.25 N, to 1 l with distilled water. This solution must be standardized daily against the dilute potassium dichromate solution, 0.025 N, following the same procedure as the standardization of the ferrous ammonium sulfate titrant, 0.25 N.

Ferroin indicator solution: dissolve 1.485 g 1,10-phenanthroline monohydrate and 0.695 g ferrous sulfate, FeSO₄ · 7H₂O, in water and dilute to 100 ml. Alternatively, a commercially prepared indicator can be purchased.

* References for this section are found on page 3-395.

** Corning 5000 or equivalent.

† Corning 2360, 91548, or equivalent.

Silver sulfate, Ag_2SO_4 , reagent powder.

Mercuric sulfate, HgSO_4 , analytical-grade crystals.

Procedure

Place several boiling stones or glass beads in the reflux flask. Add 20.0 ml of sample or an aliquot diluted to 20.0 ml. Add 0.4 g HgSO_4 to the reflux flask and mix. (The 0.4 g HgSO_4 is sufficient to complex 40 mg chloride ion or up to 2000 mg/l in a 50-ml sample. If the sample chloride concentration exceeds this value, additional HgSO_4 must be added to maintain a $\text{HgSO}_4:\text{Cl}$ ratio of 10:1.)

Cool the reflux flask in an ice bath and slowly add 10 ml 0.025 N $\text{K}_2\text{Cr}_2\text{O}_7$. The sample should be continuously mixed or swirled during this step.

Add 30 ml of sulfuric acid-silver sulfate reagent to the cooled solution. This addition should be performed slowly and with constant sample swirling for two reasons: the combination of ice bath temperatures and slow addition of the sulfuric reagent is intended to minimize the loss of volatile organic compounds; and the thorough mixing of acidified samples is intended to prevent local heating that can result in superheating and the sample being blown out the condenser during reflux.

Attach sample flask to the condenser; start the cooling water and reflux for 2 hr.

Allow the flask to cool and wash down the condenser with 25 to 30 ml distilled water. If the reflux flask has a flat bottom, the final titration may be run in the same flask. If a round-bottomed flask has been used, quantitatively transfer the sample solution to a 250-ml Erlenmeyer flask, washing out the reflux flask 3 or 4 times with distilled water. After the sample has reached room temperature, add 3 drops of ferroin indicator. The quantity of ferroin indicator used on all samples should be consistent. Titrate the excess dichromate with 0.025 N ferrous ammonium sulfate. The endpoint of the titration will be indicated by a sharp color change from blue-green to reddish-brown.

A blank consisting of 20 ml distilled water is to be processed as a sample to check for reagent contamination.

Interferences

Traces of organic material from the glassware or the atmosphere may cause a positive error in the COD test.

Care should be exercised to avoid inclusion of organic materials in distilled water used for reagent preparation or sample dilution.

Glassware used in the test should be conditioned by running blank procedures to eliminate traces of organic material.

Volatile materials may be lost as the sample temperature rises during the addition of sulfuric acid and reagent. This loss can be minimized by cooling the sample flask during this step.

Chlorides are quantitatively oxidized by dichromate and represent a positive interference in the COD procedure. Mercuric sulfate is added to complex chlorides. The mercuric sulfate:chloride ratio should be at least 10:1 to minimize this interference.

Calculations

The COD of the sample is calculated as follows:

$$\text{COD mg/l} = \frac{(A - B)(N)(8000)}{S}$$

where

A = volume $\text{Fe}(\text{NH}_4)_2(\text{SO}_4)_2$ used for blank titration, ml

B = volume $\text{Fe}(\text{NH}_4)_2(\text{SO}_4)_2$ used for sample titration, ml

N = normality of $\text{Fe}(\text{NH}_4)_2(\text{SO}_4)_2$ used, eq/l

8000 = equivalent weight of oxygen, mg/eq

S = volume of sample, ml

Method 2: High Level, 50 to 800 mg/l²

The high-level COD procedure is very similar to the low-level COD procedure except for the strength of the dichromate solution, the strength of the titrant, and the optional use of a chloride-correction procedure. When the chloride concentration in the sample exceeds 1000 mg/l, the minimum reportable COD value will be 250 mg/l because of the large chloride-correction factor.

Apparatus

Reflux apparatus: consisting of 250- or 500-ml Erlenmeyer flasks with ground-glass 24/40 neck* and 300-mm jacket Liebig, West, or equivalent condensers** with 24/40 ground-glass joint

Hot plate: having sufficient power to produce 1.4 W/cm² (9 W/in.²) of heating surface, or equivalent, to ensure adequate refluxing of the sample

Reagents

Standard potassium dichromate solution, 0.250 N: dissolve 12.259 g potassium dichromate, K₂Cr₂O₇, primary standard grade, previously dried at 103°C for 2 hr, in distilled water and dilute to 1 l. The addition of 0.12 g/l sulphamic acid will eliminate interference due to nitrites in the sample at concentrations up to 6 mg/l.

Dilute potassium dichromate solution, 0.025 N: dilute 100 ml of standard potassium dichromate solution, 0.250 N, to 1 l with distilled water.

Sulfuric acid reagents: conc. H₂SO₄ containing 22 g silver sulfate, Ag₂SO₄, per 9-lb bottle. Allow 1 or 2 days for dissolution.

Standard ferrous ammonium sulfate titrant, 0.25 N: dissolve 98 g ferrous ammonium sulfate, Fe(NH₄)₂(SO₄)₂ · 6H₂O, in distilled water. Add 20 ml conc. H₂SO₄ (CAUTION!), cool, and dilute to 1 l. This solution must be standardized against K₂Cr₂O₇ daily.

Standardization of ferrous ammonium sulfate: dilute 10 ml standard potassium dichromate solution to approximately 100 ml. Add 30 ml conc. H₂SO₄ (CAUTION!) and allow to cool. Titrate with the ferrous ammonium sulfate titrant, using 2 or 3 drops of ferroin indicator.

$$\text{Normality} = \frac{(\text{ml K}_2\text{Cr}_2\text{O}_7)(0.25)}{[\text{ml Fe}(\text{NH}_4)_2(\text{SO}_4)_2]}$$

Dilute ferrous ammonium sulfate, 0.025 N: dilute 100 ml standard ferrous ammonium sulfate, 0.25 N, to 1 l with distilled water. This solution must be standardized daily against the dilute potassium dichromate solution, 0.025 N, following the same procedure as the standardization of the ferrous ammonium sulfate titrant, 0.25 N.

Ferroin indicator solution: dissolve 1.485 g 1,10-phenanthroline monohydrate and 0.695 g ferrous sulfate, FeSO₄ · 7H₂O, in water and dilute to 100 ml. Alternatively, a commercially prepared indicator can be purchased.

Silver sulfate, Ag₂SO₄, reagent powder.

Mercuric sulfate, HgSO₄, analytical-grade crystals.

Procedure

Place several boiling stones or glass beads in a reflux

* Corning 5000 or equivalent.

** Corning 2360, 91548, or equivalent.

flask. Add 20.0 ml of a sample or an aliquot diluted to 20.0 ml. Add HgSO_4 in the ratio of 10 mg HgSO_4 to 1 mg chloride, based on the mg chloride in the sample aliquot. (An addition of 1.0 g HgSO_4 will be sufficient to complex 100 mg chloride in the sample aliquot.) Swirl to dissolve the mercuric sulfate.

Cool the sample in an ice bath and slowly add 10 ml 0.25 N $\text{K}_2\text{Cr}_2\text{O}_7$. To the well-mixed solution, slowly add 30 ml sulfuric acid-silver sulfate reagent. If a high concentration of volatile organic compounds is known or suspected to be present, the sulfuric acid-silver sulfate solution can be added through the condenser of an Allihn condenser to reduce volatilization losses.

Thoroughly mix the acidified sample to prevent local heating and possible sample loss (superheated sample may be blown out of the condenser). Attach the flask to a condenser and reflux for 2 hr.

Allow the sample to cool and wash the condenser with 25 to 30 ml distilled water.

When the sample has reached room temperature, add 3 drops of ferroin indicator. Titrate the excess dichromate with 0.25 N ferrous ammonium sulfate solution until a sharp color change occurs (blue-green to reddish-brown).

A blank consisting of 20 ml distilled water must be carried through the analytical procedure to correct for reagent contamination.

For COD values greater than 800 mg/l, a smaller sample aliquot should be used. However, the volume of the aliquot should be diluted to 20 ml using a distilled water-sodium chloride solution with a chloride concentration equal to the sample.

Chloride correction:³ When the sample chloride concentration exceeds 1000 mg/l, prepare a standard curve of COD vs. mg/l chloride. This is accomplished by preparing a series of sodium chloride solutions whose chloride concentrations bracket the chloride concentration of the sample(s). These solutions are processed as COD samples and the resultant COD's are plotted vs. chloride concentration. Do not extrapolate beyond the upper or lower limits of the chloride curve.

Calculations

The COD of the sample is calculated as follows:

$$\text{COD mg/l} = \frac{[(A - B)N \times 8000] - 50 D}{S} \times 1.2$$

where

A = volume 0.25 N $\text{Fe}(\text{NH}_4)_2(\text{SO}_4)_2$ for blank titration, ml

B = volume 0.25 N $\text{Fe}(\text{NH}_4)_2(\text{SO}_4)_2$ for sample titration, ml

N = normality of $\text{Fe}(\text{NH}_4)_2(\text{SO}_4)_2$ used for titration, eq/l

8000 = equivalent weight of oxygen, mg/eq

S = volume of sample used in test, ml

D = chloride correction from COD-chloride curve

1.2 = correction factor to compensate for the different oxidation of chloride in organic-containing (sample) and nonorganic containing (NaCl-distilled water) systems.

Procedures for Sediment Samples (S1D)⁴

Apparatus

Reflux apparatus: consisting of 250- or 500-ml Erlenmeyer flasks with ground-glass 2 $\frac{1}{2}$ /40 neck* and 300-mm jacket Liebig, West, or equivalent condensers** with 2 $\frac{1}{2}$ /40 ground-glass joint

Hot plate: having sufficient power to produce 1.4 W/cm² (9 W/in.²) of heating surface, or equivalent, to ensure adequate refluxing of the sample

Reagents

Standard potassium dichromate solution, 0.250 N: dissolve 12.259 g potassium dichromate, K₂Cr₂O₇, primary standard grade, previously dried at 103°C for 2 hr, in distilled water and dilute to 1 l. The addition of 0.12 g/l sulphamic acid will eliminate interference due to nitrites in the sample at concentrations up to 6 mg/l.

Sulfuric acid reagent: conc. H₂SO₄ containing 22 g silver sulfate, Ag₂SO₄, per 9-lb bottle. Allow 1 or 2 days for dissolution.

Standard ferrous ammonium sulfate titrant, 0.250 N: dissolve 98 g ferrous ammonium sulfate, Fe(NH₄)₂(SO₄)₂ · 6H₂O, in distilled water. Add 20 ml conc. H₂SO₄ (CAUTION!), cool, and dilute to 1 l. This solution must be standardized against K₂Cr₂O₇ daily.

Standardization of ferrous ammonium sulfate: dilute 10 ml standard potassium dichromate solution to approximately 100 ml. Add 30 ml conc. H₂SO₄ (CAUTION!) and allow to cool. Titrate with ferrous ammonium titrant, using 2 or 3 drops of ferroin indicator.

$$\text{Normality} = \frac{(\text{ml K}_2\text{Cr}_2\text{O}_7)(0.25)}{[\text{ml Fe}(\text{NH}_4)_2(\text{SO}_4)_2]}$$

Ferroin indicator: dissolve 1.485 g 1,10-phenantroline monohydrate and 0.695 g ferrous sulfate, FeSO₄ · 7H₂O, in water and dilute to 100 ml. Alternatively, a commercially prepared indicator can be purchased.

Silver sulfate, Ag₂SO₄, reagent powder.

Mercuric sulfate, HgSO₄, analytical-grade crystals.

Procedure

Place several boiling stones or glass beads and 1.0 g HgSO₄ in a reflux flask.

Transfer 0.5 to 2.0 g blended, wet sediment to the flask.

Wash the sediment into the sample flask with a minimum amount of

* Corning 5000 or equivalent.

** Corning 2360, 91548, or equivalent.

distilled water (25 ml).

Add 25 ml 0.25 N $K_2Cr_2O_7$ to the flask and mix thoroughly.

Slowly, and with constant mixing, add 75 ml of sulfuric acid-silver sulfate solution. Ensure that the mixture is well mixed to avoid localized superheating.

Attach the sample flask to a condenser and reflux for 2 hr. Should the added dichromate dissipate during reflux, either: (1) repeat, using a smaller sample size; or (2) carefully add additional 0.25 N $K_2Cr_2O_7$ through the condenser. Be sure to record any added dichromate.

Allow the sample to cool and rinse the condenser with 40 to 50 ml distilled water.

Add an additional 50 ml of distilled water to the sample and allow to cool to room temperature. Add 3 to 5 drops of ferroin indicator and titrate with 0.25 N $Fe(NH_4)_2(SO_4)_2$ to a sharp color change (blue-green to reddish-brown).

For a blank, reflux 25 ml of distilled water, 25 ml 0.25 N $K_2Cr_2O_7$, 1 g $HgSO_4$, several glass beads or boiling stones, and 75 ml of sulfuric acid-silver sulfate solution for 2 hr. Treat as a sample and titrate with 0.25 N $Fe(NH_4)_2(SO_4)_2$ after cooling and adding 3 to 5 drops of ferroin indicator.

Calculations

The COD concentration of the sediment sample is calculated as follows:

$$\text{COD mg/kg (wet weight)} = \frac{(A - B)(N)(8000)}{g}$$

$$\text{COD mg/kg (dry weight)} = \frac{(A - B)(N)(8000)}{(g)(\% S)}$$

where

A = volume of 0.25 N $Fe(NH_4)_2(SO_4)_2$ for blank titration, ml

B = volume of 0.25 N $Fe(NH_4)_2(SO_4)_2$ for sample titration, ml

N = normality of $Fe(NH_4)_2(SO_4)_2$ used for titration, eq/l

8000 = equivalent weight of oxygen, mg/eq

g = wet weight of sample, g

% S = percent solids in sediment sample (expressed as a decimal fraction)

References

1. American Public Health Association. Standard Methods for the Examination of Water and Wastewater Including Bottom Sediments and Sludges. 14th Edition. APHA; New York, New York. 1193 p. (1975).
2. Environmental Protection Agency. "Manual of Methods for Chemical Analysis of Water and Wastes." Environmental Monitoring and Support Laboratory, EPA; Cincinnati, Ohio (1979).
3. Burns, E. R., and Marshall, C. "Correction for Chloride Interference in the Chemical Oxygen Demand Test." Journal of Water Pollution Control Federation 37:1716-1721 (1965).
4. Great Lakes Region Committee on Analytical Methods. "Chemistry Laboratory Manual for Bottom Sediments." U. S. Department of the Interior, Great Lakes Region; Chicago, Illinois. 96 p. (1968).

SEDIMENT OXYGEN DEMAND

Sediments are generally in a reduced chemical state and have a potential to remove oxygen from overlying water. This results from the migration of dissolved oxygen to the sediment water interface followed by subsequent chemical reaction and/or the migration of reduced chemical species (ferrous iron, manganous manganese, sulfide) from the sediments to the overlying water followed by subsequent oxidation. The sediment oxygen demand procedure characterizes sediments in terms of rate of exertion of oxygen demand.

The procedure is a lengthy one that may require days or weeks to acquire the data. The actual time required will depend on the rate of oxygen demand exertion by the sample. A more restrictive aspect of the sediment oxygen demand procedure is that it should be run in situ. Edberg and Hofsten^{1*} compared in situ and laboratory-incubated sediments and observed that laboratory-incubated samples only exerted 40 percent of the in situ demand with a range of 9 to 100 percent. The observed rate of oxygen demand exertion doubled during 6 to 21 days of laboratory storage and was attributed to the development of a microbial population and/or increased surface area exposure due to burrowing activity and gas evolution.

Sample Collection and Storage

The preferred method of running this procedure would be in situ which would not require the collection of samples. However, if it is necessary to run the procedure in the laboratory, the sample should be collected and placed in a glass or plastic container. The container should be completely filled to exclude any entrapped air and tightly sealed. The sediment oxygen demand procedure should be initiated immediately on return to the laboratory.

Only field moist samples should be used for the test as dried and frozen samples will have been subjected to air oxidation.

* References for this section can be found on page 3-403.

Sample handling and atmospheric contact with the moist sample should also be minimized to decrease the effects of atmospheric oxidation. During transport, the samples should be kept at 4°C.

Procedures for Sediment Samples^{1,2}

Method 1: In Situ

Apparatus

Submerged chamber: chambers have been reported in the literature as ranging from 33 to 115 cm in diameter.^{1,2} A schematic representation of these chambers is shown in Figure 3-47. Chambers are embedded in sediments to an outside flange. The flange prevents the apparatus from sinking further into the sediments and the chamber extension into the sediments restricts interstitial water transfer

The apparatus should have an instrument port for inserting a dissolved oxygen electrode or a permanently mounted dissolved oxygen probe. Additional sampling ports can be added if desired. The chamber should also incorporate some method of stirring (magnetic stirrer, or a method of pumping water through the chamber) so that the dissolved oxygen measurements are not diffusion limited

Dissolved oxygen meter, Yellow Springs Instrument, or equivalent: equipped with sufficient cable to reach the sediments

Procedure

Calibrate the dissolved oxygen meter. Insert the electrode in the chamber and lower the chamber in place. Ideally, the chamber should be inspected by divers to ensure the device has correctly penetrated the bottom sediments.

Measure the dissolved oxygen concentration within the chamber as a function of time. Water temperature within the chamber should also be measured and recorded.

If additional parameters are to be measured, withdraw the sample from the chamber with a syringe. Process the water sample for that specific parameter as indicated elsewhere in this manual. Special precautions should be taken to avoid reaeration of the sample.

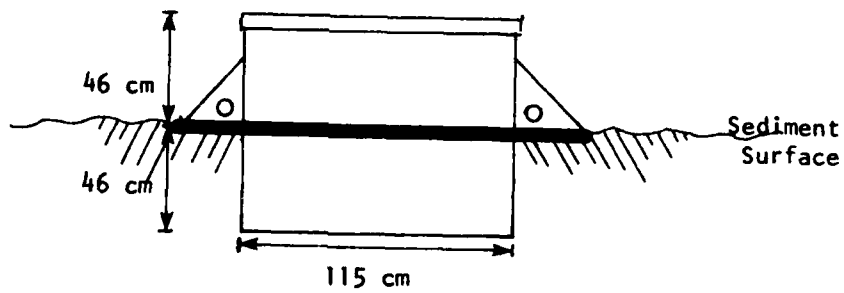
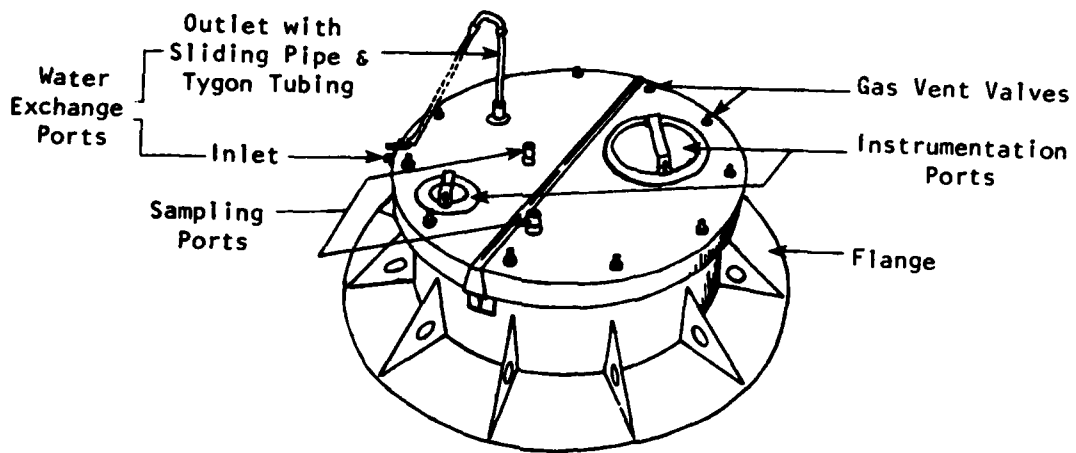

Figure 3-47. In situ sediment oxygen demand chamber

Calculations

The initial amount of oxygen in the chamber can be calculated as follows:

$$A_0 = \frac{100(\pi r^2 h)X}{\pi r^2}$$

where

r^2 = radius of the chamber, cm

h = internal height of the chamber above the sediments, cm

X = measured dissolved oxygen concentration, mg/l

A_0 = amount of oxygen in the chamber at time zero, mg

The calculated oxygen values can then be used to calculate the rate of oxygen depletion:

$$R \text{ mg/m}^2/\text{day} = \frac{A_2 - A_1}{t_2 - t_1}$$

where

R = rate of oxygen uptake, mg/m²/day

A_2 = oxygen within the chamber at time 2, mg

A_1 = oxygen within the chamber at time 1, mg

t_2 = second sampling period, days

t_1 = first sampling period, days

Method 2: Laboratory (SID)³

Apparatus

Laboratory oxygen analyzer

Magnetic stirrer with 1-in. Teflon-coated magnets

Incubator, 20°C

Wide-mouth cylindrical jars: with screw cap and sealed probe; minimum mouth opening of 11 cm; height of 25 cm; for use in making O₂ uptake apparatus (Figure 3-48)

Glass petri dish with cover

Glass petri dish support

Asbestos sheet, 15 by 15 by 0.5 cm

Reagents

Distilled water: water used for solutions and for preparation of the dilution water must be of the highest quality, distilled from a block tin or all-glass still, contain less than 0.01 mg/l copper, and be free of chlorine, chloramines, caustic alkalinity, organic

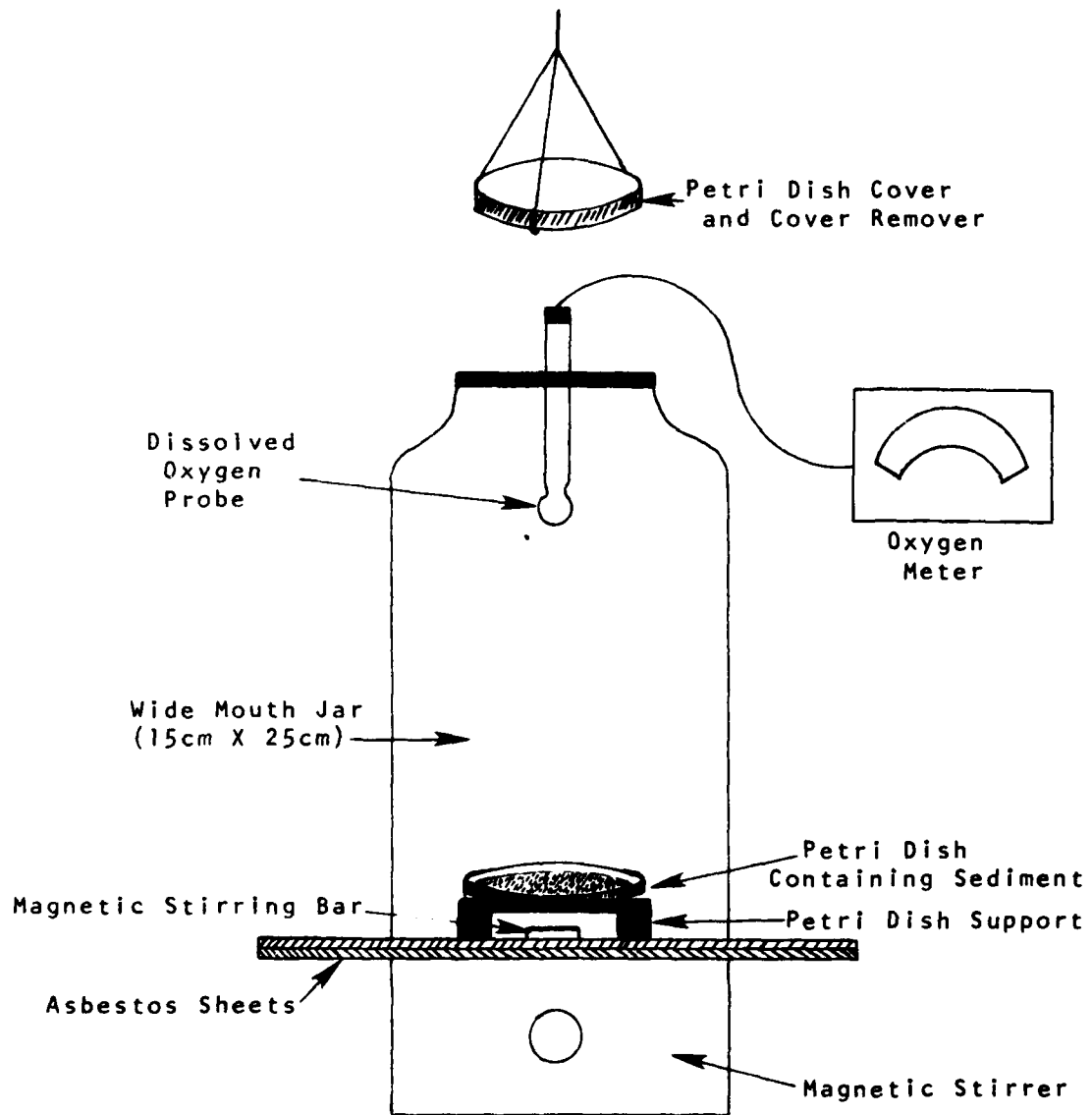

Figure 3-48. Laboratory sediment oxygen demand chamber

material, or acids.

Phosphate buffer solution: dissolve 8.5 g potassium dihydrogen phosphate, KH_2PO_4 ; 21.75 g dipotassium hydrogen phosphate, K_2HPO_4 ; 33.4 g disodium hydrogen phosphate heptahydrate, $\text{Na}_2\text{HPO}_4 \cdot 7\text{H}_2\text{O}$; and 1.75 g ammonium chloride, NH_4Cl , in about 500 ml distilled water and dilute to 1 l. The pH of this buffer should be 7.2 without further adjustment. If dilution water is to be stored in the incubator, the phosphate buffer should be added just prior to using the dilution water.

Magnesium sulfate solution: dissolve 22.5 g $\text{MgSO}_4 \cdot 7\text{H}_2\text{O}$ in distilled water and dilute to 1 l.

Calcium chloride solution: dissolve 27.5 g anhydrous CaCl_2 in distilled water and dilute to 1 l.

Ferric chloride solution: dissolve 0.25 g $\text{FeCl}_3 \cdot 6\text{H}_2\text{O}$ in distilled water and dilute to 1 l.

Procedure

Store dilution water in cotton-plugged bottles for a sufficient length of time to become saturated with dissolved oxygen.

The water may also be aerated by shaking a partially filled bottle or with a supply of clean compressed air. Situations may be encountered where it is desired to use stabilized river water to check stream performance with laboratory procedure. The distilled water used should be as near 20°C as possible and of the highest purity. Place the desired volume of distilled water in a suitable bottle and add 1 ml each of phosphate buffer, magnesium sulfate, calcium chloride, and ferric chloride solutions for each liter of water.

Set up the apparatus as shown in Figure 3-48. Place two asbestos sheets on a magnetic stirrer to prevent heat transfer and place the wide-mouth jar on the asbestos sheets.

Weigh a subsample of moist, blended sediment and place in a petri dish. Cover the petri dish and place in the bottom of the oxygen uptake chamber. Support the petri dish off the bottom so the magnetic stirrer can be used.

Fill the uptake chamber with a known volume of dilution water. Remove the cover of the petri dish.

Insert a standardized dissolved oxygen probe in the cap of the oxygen uptake chamber and seal the chamber with the cap. The

cap should be lined with Teflon tape or plasticizer to ensure the seal is airtight. The oxygen probe should be inserted far enough so that it is in the dilution water.

Start the magnetic stirrer to simulate the flow in the vicinity of the sediment source. The agitation should not cause the sediment to be resuspended.

Take dissolved oxygen readings at various time intervals. The number of readings will depend on the required frequency which, in turn, will depend on the observed rate of oxygen uptake.

The temperature in the uptake apparatus should also be measured or, preferably, controlled in a constant-temperature room as temperature can affect the rate of oxygen uptake. The rate of oxygen uptake approximates Van't Hoff's rule, with the rate approximately doubling for a 10-degree rise in temperature.

Calculations

The initial amount of oxygen in the uptake chamber can be calculated based on the volume of water used and the initial oxygen concentration as follows:

$$A_o = (V_o)(C_o)$$

where

A_o = amount of oxygen, mg

V_o = volume of water used, l

C_o = oxygen concentration at time zero, mg/l

The rate of oxygen uptake can then be calculated based on the change in the amount of oxygen in the chamber:

$$M = \frac{A_2 - A_1}{(t_2 - t_1)g}$$

where

M = rate of oxygen uptake, mg/g/day

A_1 = calculated amount of oxygen in the chamber at time 1, mg

A_2 = calculated amount of oxygen in the chamber at time 2, mg

t_1 = elapsed time from the start of the test to time 2, days

t_2 = elapsed time from the start of the test to time 1, days

g = wet weight of sediment, g

References

1. Edberg, N., and Hofsten, B. V. "Oxygen Uptake of Bottom Sediments Studies in situ and in the Laboratory." Water Research 7:1285-1294 (1973).
2. Sonzogni, W. C., Larsen, D. P., Malueg, K. W., and Schuldt, M. D. "Use of Large Submerged Chambers to Measure Sediment-Water Interactions." Water Research 11:461-464 (1977).
3. Great Lakes Region Committee on Analytical Methods. "Chemistry Laboratory Manual for Bottom Sediments." U. S. Department of the Interior, Great Lakes Region; Chicago, Illinois. 96 p. (1968).

In accordance with letter from DAEN-RDC, DAEN-ASI dated 22 July 1977, Subject: Facsimile Catalog Cards for Laboratory Technical Publications, a facsimile catalog card in Library of Congress MARC format is reproduced below.

Plumb, Russell H., Jr.

Procedures for handling and chemical analysis of sediment and water samples / by Russell H. Plumb, Jr. (Great Lakes Laboratory, State University College at Buffalo). -- Vicksburg, Miss. : U.S. Army Engineer Waterways Experiment Station, 1981.

478 p. in various pagings : ill. -- (Technical report / U.S. Army Engineer Waterways Experiment Station ; EPA/CE-81-1)

"Prepared for U.S. Environmental Protection Agency/Corps of Engineers Technical Committee on Criteria for Dredged and Fill Material under Contract EPA-4805572010."

"Monitored by Large Lakes Laboratory, U.S. Environmental Protection Agency."

Published in three-ring binder.
Includes bibliographies.

1. Chemistry, Analytic.
2. Dredging spoil
3. Fills (Earthwork).
4. Sediments (Geology).

Plumb, Russell H., Jr.

Procedures for handling and chemical analysis : ... 1981.
(Card 2)

5. Water--Analysis. I. Environmental Protection Agency/Corps of Engineers Technical Committee on Criteria for Dredged and Fill Material. II. United States. Environmental Protection Agency. Large Lakes Laboratory. III. U.S. Army Engineer Waterways Experiment Station. Environmental Laboratory. IV. Title V. Series: Technical report (U.S. Army Engineer Waterways Experiment Station) ; EPA/CE-81-1.
TA7.W34ep no.EPA/CE-81-1

END

DATE
FILMED

10-81

DTIC