

AD-A103 863

WISCONSIN UNIV-MADISON MATHEMATICS RESEARCH CENTER

F/6 7/4

THE NUMERICAL SOLUTION OF A QUASILINEAR PARABOLIC EQUATION ARIS--ETC(U)

AUG 81 P MARKOWICH; M RENARDY

DAAG29-80-C-0041

UNCLASSIFIED

MRC-TSR-2255

NL

1 4 1
40
30 1987



END
DATE
FILMED
0 8
DTIC

LEVEL

2

AD A103863

MRC Technical Summary Report #2255 ✓

THE NUMERICAL SOLUTION OF A QUASILINEAR
PARABOLIC EQUATION ARISING IN POLYMER
RHEOLOGY

P. Markowich and M. Renardy

**Mathematics Research Center
University of Wisconsin-Madison
610 Walnut Street
Madison, Wisconsin 53706**

August 1981

(Received June 5, 1981)

DTIC
ELECTE
SEP 8 1981

DTIC FILE COPY

**Approved for public release
Distribution unlimited**

Sponsored by

U. S. Army Research Office
P. O. Box 12211
Research Triangle Park
North Carolina 27709

National Science Foundation
Washington, D. C. 20550

81 9 08 106

THE UNIVERSITY OF WISCONSIN-MADISON
MATHEMATICS RESEARCH CENTER

THE NUMERICAL SOLUTION OF A QUASILINEAR PARABOLIC
EQUATION ARISING IN POLYMER RHEOLOGY

P. Markowich^{*,1,2} and M. Renardy^{** ,1}

Technical Summary Report #2255

August 1981

ABSTRACT

This paper is concerned with a numerical study of the equation

$$\rho \ddot{u} = 3\eta \frac{\partial^2}{\partial x \partial t} \left(-\frac{1}{u_x} \right) + \frac{\partial}{\partial x} \int_{-\infty}^t a(t-s) \left(\frac{u_x(t)}{u_x^2(s)} - \frac{u_x(s)}{u_x^2(t)} \right) ds$$

where $u(x,t)$ is real valued for $x \in [-1,1]$ and $t \in \mathbb{R}$ with the boundary condition

$$3\eta \frac{\partial}{\partial t} \left(-\frac{1}{u_x} \right) + \int_{-\infty}^t a(t-s) \left(\frac{u_x(t)}{u_x^2(s)} - \frac{u_x(s)}{u_x^2(t)} \right) dt = f(t)$$

at $x = \pm 1$. This problem is a model equation for elongation of a thin filament of a polymeric liquid when the force f is applied at both ends. The initial condition is $u(x, -\infty) = \varphi(x)$. The unknown variable $u(x,t)$ denotes the position of a fluid particle (in a deformed state at time t), which is at position x in space in a certain reference configuration. In this reference state the filament is assumed to be cylindrical. $a(t)$ is a memory kernel, ρ denotes the density of the fluid and η the Newtonian contribution to the viscosity. We set up a difference scheme for this problem and show the convergence under certain assumptions on f and we report computations.

AMS(MOS) Subject Classifications: 35K55, 35Q20, 45K05, 65M10, 76A10

Key Words: Viscoelastic Liquids, Quasilinear Parabolic Systems, Numerical Approximation on Infinite Intervals

Work Unit Number 3 - Numerical Analysis and Computer Science

* Supported by the Austrian Ministry of Science and Research and the Mathematics Research Center, Madison, Wisconsin.

** Supported by the Deutsche Forschungsgemeinschaft.

¹Sponsored by the United States Army under Contract No. DAAG29-80-C-0041.

²This material is based upon work supported by the National Science Foundation under Grant No. MCS-7927062.

SIGNIFICANCE AND EXPLANATION

This paper is concerned with the study of a model equation for the elongation of a filament of a polymeric liquid when a force is applied to the ends of the filament. Mathematically the equation has the form of a nonlinear partial integrodifferential equation for the position of a fluid particle in time and space. However this equation can be transformed to a quasilinear parabolic system. Parameters of the equation are the density of the fluid, the Newtonian contribution to the viscosity and certain relaxation constants which represent the 'memory' of the fluid.

Our focus is the numerical investigation and therefore, a difference method is set up and its convergence is proved under the assumption that the force which is applied to the ends of the filament is small in an appropriate norm (this is the case for which an existence and uniqueness theorem was proved). Computations are reported.

Accession For	
NTIS GRA&I	<input checked="" type="checkbox"/>
DTIC TAB	<input type="checkbox"/>
Unannounced	<input type="checkbox"/>
Justification	
By _____	
Distribution/	
Availability Codes	
Dist	Avail and/or Special
A	

The responsibility for the wording and views expressed in this descriptive summary lies with MRC, and not with the authors of this report.

THE NUMERICAL SOLUTION OF A QUASILINEAR PARABOLIC
EQUATION ARISING IN POLYMER RHEOLOGY

P. Markowich^{*,1,2} and M. Renardy^{** ,1}

1. INTRODUCTION

We present a numerical study of a model equation describing the stretching of a filament of a polymeric liquid, when a force f is applied to both ends:

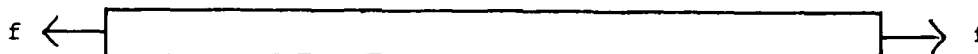

The model is based on the following assumptions: The polymer is incompressible and fulfills the "rubber-like liquid" constitutive relation [3]. Moreover, the filament is thin and hence the originally three-dimensional problem can be approximated (formally) by an equation which is one-dimensional in space.

Under these assumptions, the following model equation was derived in [7].

$$(1.1) \quad \rho \ddot{u} = 3\eta \frac{\partial^2}{\partial x \partial t} \left(-\frac{1}{u_x} \right) + \frac{\partial}{\partial x} \int_{-\infty}^t a(t-s) \left(\frac{u_x(t)}{u_x^2(s)} - \frac{u_x(s)}{u_x^2(t)} \right) ds$$

for $x \in [-1,1]$, $t \in \mathbb{R}$

* Supported by the Austrian Ministry of Science and Research and the Mathematics Research Center, Madison, Wisconsin.

** Supported by Deutsche Forschungsgemeinschaft.

¹Sponsored by the United States Army under Contract No. DAAG29-80-C-0041.

²This material is based upon work supported by the National Science Foundation under Grant No. MCS-7927062.

$$(1.2) \quad 3\eta \frac{\partial}{\partial t} \left(-\frac{1}{u_x} \right) + \int_{-\infty}^t a(t-s) \left(\frac{u_x(t)}{u_x^2(s)} - \frac{u_x(s)}{u_x^2(t)} \right) ds = f(t)$$

at $x = \pm 1, t \in \mathbb{R}$

$$(1.3) \quad u(x, t = -\infty) = \varphi(x)$$

for $x \in [-1, 1]$

The subscript x denotes partial differentiation with respect to x , and "dot" denotes partial differentiation with respect to t . The unknown variable $u(x, t)$ is the position of a fluid particle in a "deformed" state (at time t), which is at position x in an "undeformed" reference state. In this reference state the filament is assumed to be cylindrical. Thus the thickness of the filament in the initial state $u = \varphi(x)$ is proportional to $\frac{1}{\varphi'(x)}$.

We have normalized the length scale such that the filament has length 2 in the reference state. The resulting scaling factor is absorbed into ρ , which denotes the density of the filament multiplied by the square of half the length in the reference state. η denotes a Newtonian contribution to the viscosity, and f the force acting on the ends divided by the cross-sectional area in the reference state.

The memory kernel a has the form

$$(1.4) \quad a(t) = \sum_{i=1}^M K_i e^{-\lambda_i t}; \quad K_i, \lambda_i > 0.$$

(more general kernels were considered in [7]).

A problem closely related to (1.2) was investigated analytically by Lodge, McLeod and Nohel [4] and numerically by Nevanlinna [6]. They regard (1.2) as a history value problem: u_x is given for $t > 0$, and $f(t) = 0$

for $t > 0$. Their results hold for a class of kernels a and functions $F(u_x(t), u_x(s))$ under the integral that include those in (1.2).

In our current setting, (1.2) was investigated both analytically and numerically in [5] as a model for the elongation of the filament, when inertial forces are neglected. It was shown there that if f is small in the sense of an exponentially weighted L^∞ -norm or if f converges to 0 exponentially as $t \rightarrow -\infty$ and $f(t) = 0$ for $t > t_0$, t_0 finite, then problem (1.2) has a unique solution globally in time which satisfies the initial condition at $t = -\infty$. This solution lies again in an exponentially weighted L^∞ -space. In [7], Renardy showed that, for the case of small f , a similar existence result holds for the full problem (1.1). This equation was transformed to a quasilinear parabolic system that, together with (1.2), constitutes a Neumann problem. For technical reasons, weighted Sobolev (L^2 -based) spaces were used instead of weighted L^∞ -spaces here.

For the boundary problem (1.2), it was also shown that solutions depend continuously on η even as $\eta \rightarrow 0$. No result like this is yet known for the full spatial problem.

Although this does not affect the mathematics, we wish to remark that only $f > 0$ makes sense physically, because an attempt to compress the filament would result in buckling.

In this paper, we devise a finite difference method for the numerical solution of (1.1) - (1.3), and we show the convergence of this method for small forces f and the initial condition $\varphi(x) = x$. Our proof uses discrete analogues of the weighted Sobolev spaces employed in the analytical theory.

The paper is organized as follows. Chapter 2 recalls the existence result given in [7], chapter 3 contains the convergence proof for the difference scheme, and computations are reported in chapter 4.

2. ANALYTICAL THEORY

We study the problem (1.1) - (1.3) with a kernel of the form (1.4). The existence result we present is "local" in the sense that f is "small" in a certain norm that will be defined below.

Definition 2.1:

Let Z be a Banach space. Then we denote by $H^n(Z)$ the space of all functions $\mathbb{R} \rightarrow Z$ whose first n derivatives are square-integrable in the Bochner sense. Moreover, let

$$Y^{\sigma,n}(Z) = \{u : \mathbb{R} \rightarrow Z \mid e^{\sigma t}u, e^{-\sigma t}u \in H^n(\mathbb{R}, Z)\}$$

and

$$X^{\sigma,n}(Z) = \{u : \mathbb{R} \rightarrow Z \mid e^{-\sigma t}u \in H^n(\mathbb{R}, Z), \exists u_\infty \in Z \text{ such that } e^{\sigma t}(u-u_\infty) \in H^n(\mathbb{R}, Z)\}$$

The natural norms in $Y^{\sigma,n}(Z)$ and $X^{\sigma,n}(Z)$ are

$$\|u\|_{Y^{\sigma,n}(Z)} = \|e^{\sigma t}u\|_{H^n(\mathbb{R}, Z)} + \|e^{-\sigma t}u\|_{H^n(\mathbb{R}, Z)}$$

and

$$\|u\|_{X^{\sigma,n}(Z)} = \|e^{-\sigma t}u\|_{H^n(\mathbb{R}, Z)} + \|u_\infty\|_Z + \|e^{\sigma t}(u-u_\infty)\|_{H^n(\mathbb{R}, Z)}$$

The boundary problem has been discussed both analytically and numerically in an earlier paper [5]. It was shown there that, if σ is chosen small enough, then, for any given $\alpha \in \mathbb{R}^+$ and $f \in Y^{\sigma,n}(\mathbb{R})$ with sufficiently small norm, there is a unique solution u_x satisfying $u_x - \alpha \in X^{\sigma,n}(\mathbb{R})$. Moreover $\|u_x - \alpha\|$ converges to zero as $\|f\|$ converges to zero. (In [5], we used L^∞ -based rather than L^2 -based spaces, but this does not affect the proofs). Moreover, a numerical scheme was analyzed and convergence was proved. In view of these results, we shall henceforth assume that (1.2) has been solved, and examine (1.1) with given Neumann boundary conditions

$$(2.1) \quad u_x = b_1(t) \text{ at } x = +1, \quad u_x = b_{-1}(t) \text{ at } x = -1$$

where $b_1 - \alpha_1, b_{-1} - \alpha_{-1} \in X^{\sigma, n}(\mathbb{R})$ for certain $\alpha_1, \alpha_{-1} \in \mathbb{R}^+$.

This problem was analyzed in chapters 3 and 4 of [7], and in the following we quote those results needed in the present paper. Following [7], we transform (1.1) to a system of equations, which can be classified as quasilinear parabolic. For this we substitute

$$(2.2) \quad \begin{aligned} p &= u_x \\ q &= u_{xx} \\ r &= \dot{u} \\ g_1^i &= \int_{-\infty}^t e^{-\lambda_i(t-s)} (u_x(s) - u_x(t)) ds \\ g_2^i &= \int_{-\infty}^t e^{-\lambda_i(t-s)} \left(\frac{u_{xx}(s)}{u_x^3(s)} - \frac{u_{xx}(t)u_x(s)}{u_x^4(t)} \right) ds \\ g_3^i &= \int_{-\infty}^t e^{-\lambda_i(t-s)} (u_x^{-2}(s) - u_x^{-2}(t)) ds \\ g_4^i &= \int_{-\infty}^t e^{-\lambda_i(t-s)} \left(u_{xx}(s) - \frac{u_{xx}(t)u_x^2(t)}{u_x^2(s)} \right) ds \end{aligned}$$

With these substitutions, (1.1) is transformed into the following system

$$\dot{p} = r_x$$

$$\dot{q} = r_{xx}$$

$$\dot{r} = \frac{1}{p}(3\eta p^{-2} r_{xx} - 6\eta p^{-3} q r_x - 2p \sum_{i=1}^n \kappa_i g_2^i - \frac{1}{p^2} \sum_{i=1}^n \kappa_i g_4^i)$$

$$(2.3) \quad \dot{g}_1^i = -\lambda_i g_1^i - \frac{r_x}{\lambda_i}$$

$$\dot{g}_2^i = -\lambda_i g_2^i - \frac{r_{xx}}{p} \left(g_1^i + \frac{p}{\lambda_i}\right) + \frac{4r_x q}{p^5} \left(g_1^i + \frac{p}{\lambda_i}\right)$$

$$\dot{g}_3^i = -\lambda_i g_3^i + \frac{2r_x}{\lambda_i p^3}$$

$$\dot{g}_4^i = -\lambda_i g_4^i - r_{xx} p^2 \left(g_3^i + \frac{1}{\lambda_i p^2}\right) - 2r_x p q \left(g_3^i + \frac{1}{\lambda_i p^2}\right)$$

The boundary conditions are now

$$(2.4) \quad \begin{aligned} p &= b_1(t), \quad r_x = \dot{b}_1(t) \quad \text{at } x = 1 \\ p &= b_{-1}(t), \quad r_x = \dot{b}_{-1}(t) \quad \text{at } x = -1 \end{aligned}$$

(let us assume that $b_1 - \alpha_1$, $b_{-1} - \alpha_{-1}$ are at least in $X^{\sigma,1}(\mathbb{R})$). Since the boundary condition for p follows from (2.3) and the boundary condition for r_x , provided it is satisfied initially, we can ignore it.

If $\dot{b}_1 = 0$, $\dot{b}_{-1} = 0$, then, for any $p_0 \in H^2[-1,1]$ with $p_0 > 0$, a trivial solution of (2.3) is given by $p = p_0$, $q = \frac{\partial p_0}{\partial x}$, $r = 0$,

$g_1^i = g_2^i = g_3^i = g_4^i = 0$. For the following, it is convenient to set

$$\hat{r} = r - \frac{\dot{b}_1 - \dot{b}_{-1}}{4} x^2 + \frac{\dot{b}_1 + \dot{b}_{-1}}{2} x, \quad \text{so that the boundary condition for}$$

\hat{r} is $\hat{r}_x = 0$ at $x = \pm 1$. Moreover, let y denote

$(p-p_0, q-q_0, \hat{r}, g_1^i, g_2^i, g_3^i, g_4^i)$. By A we denote the linearization of the right hand side of (2.3) at the trivial solution, i.e. the operator

$$\begin{aligned} & (p, q, \hat{r}, g_1^i, g_2^i, g_3^i, g_4^i) \rightarrow \left(\hat{r}_x, \hat{r}_{xx}, \frac{3n}{\rho} p_0^{-2} \hat{r}_{xx} - \frac{6n-3}{\rho} p_0^{-3} q_0 \hat{r}_x - \frac{2p_0}{\rho} \sum_{i=1}^n \kappa_i g_2^i \right. \\ & - \frac{1}{p_0^2} \sum_{i=1}^n \kappa_i g_4^i, -\lambda_i g_1^i - \frac{\hat{r}_x}{\lambda_i}, -\lambda_i g_2^i - \frac{\hat{r}_{xx}}{p_0 \lambda_i} + \frac{4r_x q_0}{p_0 \lambda_i}, -\lambda_i g_3^i + \frac{2\hat{r}_x}{\lambda_i p_0}, \\ & \left. - \lambda_i g_4^i - \frac{\hat{r}_{xx}}{\lambda_i} - \frac{2r_x q_0}{p_0 \lambda_i} \right) \end{aligned}$$

The boundary $\hat{r}_x = 0$ is incorporated in A . Let X_2 denote the space $H^2[-1,1] \times (H^1[-1,1])^2 \times (H^1[-1,1])^{4M}$, and let $D(A)$, $N(A)$ and $R(A)$ denote the domain, nullspace and range of A , regarded as an operator in X_2 . We quote the following result from [7].

Theorem 2.1:

Let $p_0 \in H^2[-1,1]$ be given such that $p_0 > 0$, and let $q_0 = \frac{\partial p_0}{\partial x}$. Moreover, let n be an integer > 1 . Then, if σ is chosen small enough and $\dot{b}_1(t)$ and $\dot{b}_{-1}(t)$ have sufficiently small norm in $Y^{\sigma,n}(\mathbb{R})$, equations (2.3), (2.4) have a solution, for which y (as defined above) is in $X^{\sigma,n+1}(N(A)) \oplus (Y^{\sigma,n}(D(A) \cap R(A)) \cap Y^{\sigma,n+1}(R(A)))$. y depends smoothly on \dot{b} .

Remarks:

1. If \dot{b} is sufficiently smooth, it is easy to use a bootstrapping argument to estimate higher derivatives of y with respect to x . We shall not demonstrate this here, but we shall use it in the consistency proof for the numerical method.
2. In [7], the above theorem was only formulated for the special case $p_0 = 1$. The proof, however, carries over to the general case.

3. The "rubberlike liquid" constitutive relation has not been entirely successful in comparison with experiments, and several modifications have been suggested (see e.g. [3]). Some of these modified equations have a similar mathematical structure and are accessible to the same kind of analysis. In this paper we confine our attention to the rubberlike liquid as the simplest case.

3. THE DISCRETE PROBLEM

In this chapter we set up a discretization scheme for (1.1), (1.2) and prove convergence for small forces f and the initial condition $u(x, -\infty) = x$. The infinite interval, on which (1.1) - (1.3) is posed, is cut at a finite point $-T \ll 0$, and the solution on $(-\infty, T]$ is approximated by its initial value. We thus get an approximation u^T as solution of the following equation:

$$(3.1) \quad \rho \ddot{u}^T - 3\eta \frac{\partial^2}{\partial x \partial t} \left(-\frac{1}{u_x^T} \right) - \int_{-\infty}^{-T} a(t-s) ds \cdot \left(\frac{\partial}{\partial x} \left(\frac{u_x^T(t)}{(\varphi'(x))^2} - \frac{\varphi'(x)}{(u_x^T(t))^2} \right) \right. \\ \left. - \frac{\partial}{\partial x} \int_{-T}^t a(t-s) \left(\frac{u_x^T(t)}{(u_x^T(s))^2} - \frac{u_x^T(s)}{(u_x^T(t))^2} \right) ds = 0 \right.$$

for $(x, t) \in [-1, 1] \times [-T, \infty)$

$$(3.2) \quad u^T(x, -T) = \varphi(x)$$

$$(3.3) \quad 3\eta \dot{u}_x^T + \int_{-\infty}^{-T} a(t-s) ds \cdot \left(\frac{(u_x^T(t))^3}{(\varphi'(x))^2} - \varphi'(x) \right) \\ + \int_{-T}^t a(t-s) \left(\frac{(u_x^T(t))^3}{(u_x^T(s))^2} - u_x^T(s) - f(t)(u_x^T(t))^2 \right) = 0$$

at $x = \pm 1$, $t > -T$.

As a next step, this "finite interval problem" will be approximated by a finite difference procedure. In [5], we studied the boundary problem (3.3), using an implicit Euler scheme. Convergence uniformly in η was proved, moreover, it was shown that the discretization preserves the property that, for appropriate f 's, solutions converge to limits exponentially as $t \rightarrow \pm\infty$. Here, we shall use the same kind of scheme for the full spatio-temporal

problem (3.1) - (3.3). Let us first introduce some notation.

Definition 3.1:

Let $N \in \mathbb{N}$, $h = \frac{1}{N}$, and for $n \in \mathbb{Z}$ let $u^n = (u_{-N-1}^n, u_{-N}^n, \dots, u_N^n, u_{N+1}^n) \in \mathbb{R}^{2N+3}$. Then we define the "spatial" difference quotients

$$\Delta^+ u_i^n = \frac{u_{i+1}^n - u_i^n}{h}$$

$$\Delta^- u_i^n = \frac{u_i^n - u_{i-1}^n}{h}$$

$$\Delta u_i^n = \frac{u_{i+1}^n - u_{i-1}^n}{2h}$$

and the "temporal" difference quotients

$$\delta^+ u_i^n = \frac{u_i^{n+1} - u_i^n}{k}$$

$$\delta^- u_i^n = \frac{u_i^n - u_i^{n-1}}{k}$$

$$\delta u_i^n = \frac{u_i^{n+1} - u_i^{n-1}}{2k}$$

where $k > 0$ is given.

We set $t_n = nk$, $n \in \mathbb{Z}$, $t_{-m} = -T$ and $x_i = ih$, $i = (-N-1)(1)(N+1)$.

(3.1) is then discretized as follows (u_i^n denotes the approximation to $u(x_i, t_n)$).

$$\begin{aligned}
(3.4) \quad & \rho \delta^+ \delta^- u_i^n - 3\eta \delta^+ \Delta^+ \left(-\frac{1}{\Delta^- u_i^n} \right) - k \sum_{j=-\infty}^{-m} a(t_{n+1} - t_j) \cdot \\
& \cdot \Delta^+ \left(\frac{\Delta^- u_i^{n+1}}{\varphi'(x_i)^2} - \frac{\varphi'(x_i)}{(\Delta^- u_i^{n+1})^2} \right) - k \sum_{j=-m+1}^{n+1} a(t_{n+1} - t_j) \cdot \\
& \cdot \Delta^+ \left(\frac{\Delta^- u_i^{n+1}}{(\Delta^- u_i^j)^2} - \frac{\Delta^- u_i^j}{(\Delta^- u_i^{n+1})^2} \right) = 0
\end{aligned}$$

for $i = -N(1)N$ $n \geq -m$.

We need two initial vectors

$$(3.5) \quad u_i^{-m} = u_i^{-m-1} = \varphi(x_i), \quad i = (-N-1)(1)(N+1)$$

In 3.4 we approximated $\int_{-\infty}^{-T} a(t-s)ds$ by the discrete sum, although we could evaluate it exactly. The reason is that this facilitates the stability analysis of the schem. The sum is given by

$$(3.6) \quad k \sum_{j=-\infty}^{-m} a(t_{n+1} - t_j) = \sum_{\ell=1}^M \frac{K_\ell k e^{-\lambda_\ell (t_{n+1} - t_{-m})}}{1 - e^{-\lambda_\ell k}}$$

Let y_1^n, y_{-1}^n denote an approximation to the boundary condition

$u_x^T(1), u_x^T(-1)$. We discretize the boundary problem (3.3) as in [5]

$$\begin{aligned}
(3.7) \quad & 3\eta \frac{y_\ell^{n+1} - y_\ell^n}{k} + k \sum_{j=-\infty}^{-m} a(t_{n+1} - t_j) \left(\frac{(y_\ell^{n+1})^3}{(\varphi'(\ell))^2} - \varphi'(\ell) \right) \\
& + k \sum_{j=m+1}^{n+1} a(t_{n+1} - t_j) \left(\frac{(y_\ell^{n+1})^3}{(y_\ell^j)^2} - y_\ell^j \right) - f(t_{n+1}) (y_\ell^{n+1})^2 = 0
\end{aligned}$$

for $\ell = +1, -1, n \geq -m$.

The corresponding initial conditions are

$$(3.8) \quad y_1^{-m} = \varphi'(1), \quad y_{-1}^{-m} = \varphi'(-1)$$

Since we want a second order method with respect to k , we approximate the Neumann conditions by the symmetric difference quotient

$$(3.9) \quad \Delta u_{-N}^{n+1} = y_{-1}^{n+1}, \quad \Delta u_N^{n+1} = y_1^{n+1}.$$

The exterior grid points $(-1-h, t_{n+1})$ and $(1+h, t_{n+1})$ can be eliminated by solving (3.9) for u_{-N-1}^{n+1} and u_{N+1}^{n+1} and inserting these values into (3.4).

An efficient way to evaluate the last sum in (3.4) (the discrete approximation to the integral) is as follows. Let

$$(3.10) \quad g_{\ell i}^{n+1} = K_{\ell} k \sum_{j=-m+1}^n e^{-\lambda_{\ell}(t_{n+1}-t_j)} \frac{1}{(\Delta^- u_i^j)^2}$$

$$(3.11) \quad h_{\ell i}^{n+1} = K_{\ell} k \sum_{j=-m+1}^n e^{-\lambda_{\ell}(t_{n+1}-t_j)} \Delta^- u_i^j$$

Then the following recursions hold

$$(3.12) \quad g_{\ell i}^{n+1} - g_{\ell i}^n = K_{\ell} k e^{-\lambda_{\ell} k} \frac{1}{(\Delta^- u_i^n)^2} + (e^{-\lambda_{\ell} k} - 1) g_{\ell i}^n; \quad g_{\ell i}^{-m+1} = 0$$

$$(3.13) \quad h_{\ell i}^{n+1} - h_{\ell i}^n = K_{\ell} k e^{-\lambda_{\ell} k} \Delta^- u_i^n + (e^{-\lambda_{\ell} k} - 1) h_{\ell i}^n; \quad h_{\ell i}^{-m+1} = 0$$

and since the $n+1$ -st summand cancels out, (3.4) takes the form

$$(3.14) \quad \rho \delta^+ \delta^- u_i^n - 3\eta \delta^+ \Delta^+ \left(-\frac{1}{\Delta^- u_i^n} \right) - k \sum_{j=-\infty}^{-m} a(t_{n+1} - t_j).$$

$$\Delta^+ \left(\frac{\Delta^- u_i^{n+1}}{\varphi'(x_i)^2} - \frac{\varphi'(x_i)}{(\Delta^- u_i^{n+1})^2} \right) - \Delta^+ \left(\sum_{\ell=1}^M g_{\ell i}^{n+1} \Delta^- u_i^{n+1} - \frac{h_{\ell i}^{n+1}}{(\Delta^- u_i^{n+1})^2} \right) = 0$$

The boundary problem can be treated in an analogous way. Thus the computational solution proceeds as follows. At a particular time step, say $n+1$, y^{n+1} is calculated from (3.7) (see [5]). Then g_{li}^{n+1} , h_{li}^{n+1} are calculated from (3.12), (3.13) using the previous values (time step n). By inserting this into (3.14), a nonlinear $(2N+1)$ -dimensional system of equations is obtained (after substituting u_{N+1} , u_{-N-1} according to (3.9)). This nonlinear system is solved by Newton's method, using the values from the previous time step as a starting point for the iteration. In each iteration step the Jacobian is tridiagonal and diagonal dominant (the Gauss algorithm does not require pivoting).

In the remainder of this chapter, we restrict ourselves to the initial condition $\varphi(x) = x$. We presented the general problem, however, since we have also done computations with different initial values. For $\varphi(x) = x$, u is odd, and the procedure can be simplified by imposing the Dirichlet condition.

$$(3.15) \quad u = 0 \quad \text{at} \quad x = 0$$

and by solving in $[0,1] \times \mathbb{R}$. This cuts the dimension of the system down to $N+1$. We shall give a convergence analysis for this case.

Since we also want to approximate derivatives of u , we work in discrete Sobolev spaces. We set

$$(3.16) \quad L_h^2 = \{u = (u_0, \dots, u_{N+1}) \in \mathbb{R}^{N+2} \mid u_0 = 0, u_{N+1} = u_{N-1}\}$$

$$\|u\|_{L_h^2} = \left(h \sum_{i=1}^{N+1} |u_i|^2 \right)^{1/2}$$

$$(3.17) \quad H_h^2 = \{u \in L_h^2\}, \quad \|u\|_{H_h^2}^2 = \|u\|_{L_h^2}^2 + \|\Delta u\|_{L_h^2}^2 + \|\Delta^+ \Delta^- u\|_{L_h^2}^2$$

where Δu , $\Delta^+ \Delta^- u$ are taken componentwise and $\Delta u_{N+1} = \Delta^+ \Delta^- u_{N+1} = 0$ has been

set.

We also define for an arbitrary Banach space X :

$$(3.18) \quad L_k^2(X) = \{ \hat{u} = (u^n)_{n=-\infty}^{\infty} \mid u^n \in X, \|\hat{u}\|_{L_k^2(X)} = (k \sum_{n=-\infty}^{\infty} \|u^n\|_X^2)^{1/2} < \infty \}$$

and inductively

$$(3.19) \quad H_k^n(X) = \{ \hat{u} = (u^n)_{n=-\infty}^{\infty} \mid u^n \in X, \hat{u} \in H_k^{n-1}(X), \delta^+ \hat{u} \in H_k^{n-1}(X) \},$$

$$\|\hat{u}\|_{H_k^n(X)} = \|\hat{u}\|_{H_k^{n-1}(X)} + \|\delta^+ \hat{u}\|_{H_k^{n-1}(X)}$$

where $H_k^0(X) = L_k^2(X)$.

Our analysis will proceed in the following exponentially weighted Sobolev spaces:

$$(3.20) \quad X_{k,h}^\sigma = \{ \hat{u} = (u^n)_{n=-\infty}^{\infty} \mid (e^{-\sigma n k} u^n)_{n=-\infty}^{\infty} \in H_k^2(L_h^2) \cap H_k^1(H_h^2), \exists u^\infty \in H_h^2 \}$$

such that $(e^{\sigma n k} (u^n - u^\infty))_{n=-\infty}^{\infty} \in H_k^2(L_h^2) \cap H_k^1(H_h^2)$

$$\|\hat{u}\|_{X_{k,h}^\sigma} = \|(e^{-\sigma n k} u^n)_{n=-\infty}^{\infty}\|_{H_k^2(L_h^2)} + \|(e^{-\sigma n k} u^n)_{n=-\infty}^{\infty}\|_{H_k^1(H_h^2)}$$

$$+ \|u^\infty\|_{H_h^2} + \|(e^{\sigma n k} (u^n - u^\infty))_{n=-\infty}^{\infty}\|_{H_k^2(L_h^2)} + \|(e^{\sigma n k} (u^n - u^\infty))_{n=-\infty}^{\infty}\|_{H_k^1(H_h^2)}$$

$$(3.21) \quad Y_{k,h}^\sigma = \{ \hat{u} = (u^n)_{n=-\infty}^{\infty} \mid (e^{-\sigma n k} u^n)_{n=-\infty}^{\infty}, (e^{\sigma n k} u^n)_{n=-\infty}^{\infty} \in L_k^2(L_h^2), \}$$

$$\|\hat{u}\|_{Y_{k,h}^\sigma} = \|(e^{\sigma n k} u^n)_{n=-\infty}^{\infty}\|_{L_k^2(L_h^2)} + \|(e^{-\sigma n k} u^n)_{n=-\infty}^{\infty}\|_{L_k^2(L_h^2)}$$

$$(3.22) Z_k^\sigma = \{ \hat{f} = (f^n)_{n=-\infty}^\infty \mid (e^{-\sigma n k} f^n) \in H_k^2(\mathbb{R}), \exists f^\infty \in \mathbb{R} \ni (e^{\sigma n k} (f^n - f^\infty)) \in H_k^2(\mathbb{R}) \}$$

$$\|\hat{f}\|_{Z_k^\sigma} = \|(e^{-\sigma n k} f^n)\|_{H_k^2(\mathbb{R})} + \|(e^{\sigma n k} (f^n - f^\infty))\|_{H_k^2(\mathbb{R})} + |f^\infty|$$

These discrete spaces are defined in an analogous way as the spaces used for the analysis of the continuous problem [7].

We set $v_i^n = u_i^n - x_i y^n$, which transforms (3.4) to the equation $F_{h,k,y}(\hat{v}) = 0$, where

$$(3.23) \text{ (a) } (F_{h,k,y}(\hat{v}))_i^{n+1} = \rho \delta^+ \delta^- v_i^n + \rho x_i \delta^+ \delta^- y^n - 3\eta \delta^+ \Delta^+ \left(-\frac{1}{\Delta v_i^n y^n} \right) - k \sum_{j=-\infty}^{n+1} a(t_{n+1} - t_j) \Delta^+ \left(\frac{\Delta v_i^{n+1} + y^{n+1}}{(\Delta v_i^j + y^j)^2} - \frac{\Delta v_i^j + y^j}{(\Delta v_i^{n+1} + y^{n+1})^2} \right)$$

for $i = 1(1)N$

$$(b) (F_{h,k,y}(\hat{v}))_{N+1}^{n+1} = F_{h,k,y}(\hat{v})_{N-1}^{n+1}$$

$$(c) (F_{h,k,y}(\hat{v}))_0^{n+1} = 0$$

This formula holds also for $n+1 \leq -m$, where we have $y^{n+1} = 1$, $v_i^{n+1} = 0$.

A simple but rather lengthy calculation shows that

$$(3.24) F_{h,k,y} : X_{k,h}^{\sigma'} + Y_{k,h}^{\sigma'}$$

provided that $(y^n)_{n=-\infty}^\infty \in Z_k^{\sigma'}$. Considerations very similar to those in [5] show that this is the case if f (as of (3.3)) is in $Y^{\sigma',1}(\mathbb{R})$, $\sigma' < \sigma$ and

If $\| \cdot \|_{Y^{\sigma,1}(\mathbb{R})}$ is small enough. The boundary conditions at $x = 0,1$ are already built into the spaces. The main tool in our convergence proof is Keller's nonlinear stability-consistency concept.

Consistency follows from a rather lengthy but essential trivial calculation, which we omit. Let $v(x_i, t_n)$ denote $u(x_i, t_n) - x_i u_x(1, t_n)$, where u is the solution of (1.1)-(1.3) with $\varphi(x) = x$, and let \tilde{v} be the gridfunction with values $v(x_i, t_n)$ in (x_i, t_n) . Then the following estimate can be obtained.

$$(3.25) \quad \| F_{h,k,y}(\tilde{v}) \|_{Y_{k,h}^{\sigma'}} < \text{const.} (h^2 + k + o(e^{-(\sigma-\sigma')|t_{-m}|}))$$

provided $u - xu_x(1,t) \in X^{\sigma,3}(L^2) \cap X^{\sigma,1}(H^4)$. This holds for $f \in Y^{\sigma,4}(\mathbb{R})$ with sufficiently small norm. The constant in (3.25) is independent of h, k, t_{-m}, ρ , and $\sigma' \in [\sigma_0, \sigma_1] \subset (0, \sigma)$. Independence of η is not assured, since we do not know anything about the behaviour of the solution as $\eta \rightarrow 0$.

In deriving (3.25), the error estimates obtained in [5] for the approximation (3.7), (3.8) of the boundary condition has been used (the choice of Sobolev rather than L^∞ -based norms does not affect the validity of the reasoning given there). As far as the local discretization error is concerned, our scheme is thus second order accurate in space and first order accurate in time.

In order to investigate stability, we linearize $F_{h,k,y}$ at $\hat{v}_0 = 0$ (corresponding to $u = x$ or $f = 0$ respectively). We set

$$(3.26) \quad L_{h,k,1} = F'_{h,k,1}(0)$$

and investigate the equation

$$(3.27) \quad L_{h,k,1} \hat{w} = \hat{g}, \quad \hat{g} = (g_1^n) \in Y_{k,h}^{\sigma'}, \quad \hat{w} = (w_1^n)$$

this yields

$$(3.28) \text{ (a)} \quad \rho \delta^+ \delta^- w_1^n = 3\eta \delta^+ \Delta^+ \Delta^- w_1^n + 3k \sum_{j=-\infty}^{n+1} a(t_{n+1} - t_j).$$

$$(\Delta^+ \Delta^- w_1^{n+1} - \Delta^+ \Delta^- w_1^j) + g_1^{n+1}$$

$$(b) \quad w_0^{n+1} = 0, \Delta w_N^{n+1} = 0$$

We transform (3.28) to a "parabolic" system of difference equations by substituting

$$(3.29) \quad q_i^n = \Delta^+ \Delta^- w_i^n, r_i^n = \delta^- w_i^n, p_{\ell i}^n = kK_{\ell} \sum_{j=-\infty}^n e^{-\lambda_{\ell}(t_n - t_j)} q_i^j$$

for $\ell = 1(1)M$

Then (3.28) assumes the form

$$(3.30) \text{ (a)} \quad \rho \delta^+ r_i^n = 3\eta \Delta^+ \Delta^- r_i^{n+1} + 3k \sum_{j=-\infty}^{n+1} a(t_{n+1} - t_j) q_i^{n+1} - 3 \sum_{\ell=1}^M p_{\ell i}^{n+1} + g_i^{n+1}$$

$$(b) \quad \delta^+ p_{\ell i}^n = K_{\ell} q_i^{n+1} + \frac{e^{-\lambda_{\ell} k} - 1}{k} p_{\ell i}^n$$

$$(c) \quad \delta^+ q_i^n = \Delta^+ \Delta^- r_i^{n+1}$$

$$(d) \quad \Delta r_N^{n+1} = 0, r_0^{n+1} = 0$$

The system (3.30) is reduced further by a discrete "separation of variables", using the Fourier method (see [8]).

We set

$$(3.31) \quad w_i^n = \sum_{v=0}^{N-1} W_v^n \sin \left((2v+1) \frac{\pi}{2} x_i \right)$$

and likewise for $r_i^n, q_i^n, g_i^n, p_{\ell i}^n$ (with obvious notations R_v^n etc.). The

boundary conditions are automatically satisfied by these expansions.

With

$$(3.32) \quad Z_v^n = (R_{1v}^n, Q_v^n, R_{1v}^n, \dots, P_{M,v}^n), \quad \tilde{G}_v^n = (G_v^n, 0, 0, \dots, 0)^T,$$

the system (3.30) can be rewritten as

$$(3.33) \quad A_v(h,k)Z_v^{n+1} = Z_v^n + k\tilde{G}_v^{n+1}, \quad v = 0(1)(N-1),$$

where A_v is the $(M+2)$ -square matrix

$$(3.34) \quad A_v(h,k) = \begin{bmatrix} 1 - \frac{3nk}{\rho}\alpha_v(h) & -\frac{3k^2}{\rho} \sum_{j=-\infty}^{n+1} a(t_{n+1} - t_j) & \frac{3k}{\rho} & \dots & \frac{3k}{\rho} \\ -k\alpha_v(h) & 1 & 0 & \dots & 0 \\ 0 & -kK_1 e^{\lambda_1 k} & e^{\lambda_1 k} & & \\ \cdot & & \cdot & & \\ \cdot & & \cdot & & 0 \\ \cdot & & \cdot & & \cdot \\ 0 & -kK_M e^{\lambda_M k} & 0 & & e^{\lambda_M k} \end{bmatrix}$$

Here we have put

$$(3.35) \quad \alpha_v(h) = \frac{2[\cos((\frac{2v+1}{2})\pi) - 1]}{h^2}.$$

The reader is reminded that $\sum_{j=-\infty}^{n+1} a(t_{n+1} - t_j)$ and hence $A_v(h,k)$ does not depend on n .

The stability proof relies crucially on the following result.

Lemma 3.1:

The matrix $\frac{A_\nu(h,k) - I}{k}$ has $M + 1$ eigenvalues $\lambda_\rho(h,k,\nu)$ with positive real part (with a lower bound for the real part not depending on h, k , or ν) and a simple eigenvalue zero. Moreover, there exists a matrix $E_\nu(h,k)$, which together with its inverse is uniformly bounded for $h, k \in (0, k_0)$, $\rho \in (0, \rho_0]$, $\nu = O(1)(N-1)$, such that $E_\nu(h,k) \cdot \frac{A_\nu(h,k) - I}{k} E_\nu^{-1}(h,k)$ has the form

$$\begin{bmatrix} Y & 0 & \dots & 0 \\ 0 & & & \\ 0 & & & \\ 0 & & c(k, \rho, \frac{1}{\alpha_\nu(h)}) & \\ \vdots & & & \\ 0 & & & \end{bmatrix}$$

where Y is positive with a lower bound uniform in h, k, ρ and ν and C is analytic in all its arguments.

Proof:

The characteristic equation of $\frac{A_\nu(h,k) - I}{k}$ is given by

$$(3.36) \quad p_\nu(z) := \frac{3}{\rho} \alpha_\nu(h) \left(\sum_{i=1}^M \frac{K_i e^{\lambda_i k}}{\frac{e^{\lambda_i k} - 1}{k} - z} - k \sum_{j=-\infty}^{n+1} a(t_{n+1} - t_j) \right) + z \left(\frac{3\eta}{\rho} \alpha_\nu(h) + z \right) = 0$$

We note that $\alpha_\nu(h) < -c$ for some $c > 0$, which does not depend on ν or h . For convenience, we assume that $\lambda_1 < \lambda_2 < \dots < \lambda_n$. Obviously

$$p_\nu \left(\frac{e^{\lambda_1 k} - 1}{k} + \right) = +\infty, \quad p_\nu \left(\frac{e^{\lambda_1 k} - 1}{k} - \right) = -\infty. \quad \text{Therefore, there is at least one}$$

zero of p_v in $(\frac{e^{\lambda_i k}}{k} - 1, \frac{e^{\lambda_{i+1} k}}{k} - 1)$ for $i = 1(1)(M-1)$. Moreover, $p_v(0) = 0$, and $z = 0$ is a simple zero. We have thus accounted for M zeros of p_v , and two more are left.

We have

$$(3.37) \quad p'_v(z) = \frac{3}{\rho} \alpha_v(h) \sum_{i=1}^M \frac{\kappa_i e^{\lambda_i k}}{\left(\frac{e^{\lambda_i k}}{k} - 1 - z\right)^2} + \frac{3\eta}{\rho} \alpha_v(h) + 2z$$

For $z \in \mathbb{R}$ and $z < 0$, we find $p'_v(z) < 0$, whence p_v has no negative roots. On the other hand, we find

$$(3.38) \quad \text{Im } p'_v(z) = \frac{3}{\rho} \text{Im } z (\alpha_v(h) \sum_{i=1}^M \frac{\kappa_i e^{\lambda_i k}}{\left|\frac{e^{\lambda_i k}}{k} - 1 - z\right|^2} + \eta \alpha_v(h) + \frac{2}{3}\rho \text{Re } z)$$

If $\text{Im } p'_v(z) = 0$, we therefore have either $\text{Im } z = 0$ or $\text{Re } z > c > 0$. If z is real and $p_v(z) = 0$, then we know z cannot be negative, and if z is positive, one easily finds a lower bound for $\text{Re } z$ from (3.36). Thus we have proved the first part of the lemma.

The second part follows from elementary matrix manipulations, which we do not demonstrate here. One finds that $\gamma = -\frac{3\eta}{\rho} \alpha_v(h) + \gamma'$ where γ' is analytic in k, ρ and $\frac{1}{\alpha_v(h)}$.

Lemma 3.2:

Let the $n \times n$ -matrix C have only eigenvalues with positive real part. Then, for each $a \in L^2((-\infty, \infty); \mathbb{R}^n)$, the difference equation

$$(3.39) \quad \delta^-_k y(t) = \frac{y(t) - y(t-k)}{k} = -Cy(t) + a(t)$$

has a unique solution $y \in L^2((-\infty, \infty); \mathbb{R}^n)$ and the estimate

$$(3.40) \quad \|y\|_{L^2} \leq c \|a\|_{L^2}$$

holds with $c > 0$ independent of k and a .

Proof:

Let \bar{y} and \bar{a} be the Fourier transforms of y and a :

$$y(t) = \frac{1}{\sqrt{2\pi}} \int_{-\infty}^{\infty} \bar{y}(s) e^{2\pi i s t} ds, \quad a(t) = \frac{1}{\sqrt{2\pi}} \int_{-\infty}^{\infty} \bar{a}(s) e^{2\pi i s t} ds$$

Equation (3.39) is equivalent to

$$\frac{1 - e^{-2\pi i k}}{k} \bar{y}(s) = -C \bar{y}(s) + \bar{a}(s)$$

or

$$\bar{y}(s) = \left(\frac{1 - e^{-2\pi i k}}{k} I + C \right)^{-1} \bar{a}(s)$$

Since $\operatorname{Re} \left(\frac{1 - e^{-2\pi i k}}{k} \right) > 0$, the lemma is immediate (use Parseval's equality).

As a consequence, we have $\|\delta^- y\|_{L^2} \leq \text{const.} \|a\|_{L^2}$.

An easy corollary is that for $a \in Y^{\sigma, 0}(\mathbb{R}^n)$, there is a unique solution $y \in Y^{\sigma, 0}(\mathbb{R}^n)$ and an estimate $\|y\|_{Y^{\sigma, 0}} \leq c \|a\|_{Y^{\sigma, 0}}$ holds, provided σ is small enough (to see this, substitute $y = e^{\pm \sigma t} \bar{y}$ and apply lemma 3.2). If $C = 0$ and $a \in Y^{\sigma, 0}(\mathbb{R}^n)$, there is a solution $y \in X^{\sigma, 0}(\mathbb{R}^n)$ and an estimate $\|y\|_{X^{\sigma, 0}} \leq c \|a\|_{Y^{\sigma, 0}}$ holds (recall definition 2.1 for $Y^{\sigma, 0}, X^{\sigma, 0}$). From these results the estimate

$$(3.41) \quad \|(Z_v^n)_{n=-\infty}^{\infty}\|_{X^{\sigma', 0}(\mathbb{R}^{M+2})} + \|\delta^+ Z_v^n\|_{Y^{\sigma', 0}(\mathbb{R}^{M+2})}$$

$$\leq \text{const.} \|G_v^n\|_{Y^{\sigma', 0}(\mathbb{R}^{M+2})}$$

is immediate. The constant is independent of h, k, v , and ρ , but may

depend on η . When we rewrite the norms in $X_{k,h}^{\sigma'}$ and $Y_{k,h}^{\sigma'}$ in terms of Fourier coefficients, we immediately see that the solution of (3.27) satisfies an estimate

$$(3.42) \quad \|\hat{w}\|_{X_{k,h}^{\sigma'}} \leq \text{const.} \|\hat{g}\|_{Y_{k,h}^{\sigma'}} ,$$

i.e. we have stability unconditionally with respect to k and h , and the constant is uniform in h, k, ρ .

A simple calculation shows that, in a neighbourhood of $\hat{v} = 0, y = 1$, the derivative $F'_{h,k,y}(\hat{v})$ is uniformly Lipschitz continuous with respect to y and \hat{v} , i.e. we have

$$(3.43) \quad \begin{aligned} & \|F'_{h,k,y}(\hat{v}) - F'_{h,k,y^*}(\hat{v}^*)\|_{X_{k,h}^{\sigma'} \rightarrow Y_{k,h}^{\sigma'}} \\ & \leq \text{const.} (\|\hat{v} - \hat{v}^*\|_{X_{k,h}^{\sigma'}} + \|y - y^*\|_{Z_k^{\sigma'}}) \end{aligned}$$

If \tilde{v} denotes the solution to the exact problem, and \tilde{y} the solution to (3.7), (3.8), then $\|\tilde{y} - 1\|_{Z_k^{\sigma'}}$ and $\|\tilde{v}\|_{X_{k,h}^{\sigma'}}$ are small if $\|f\|_{Y^{\sigma',2}}$ is

small. Therefore all conditions for Keller's [1] theory are satisfied, and we obtain the final result.

Theorem 3.1:

Let σ be a positive real number chosen sufficiently small. For any $f \in Y^{\sigma,4}(\mathbb{R})$, which has sufficiently small norm in $Y^{\sigma,2}(\mathbb{R})$, there is a unique solution $((u_i^n)_{i=-N-1}^{N+1})_{n=-\infty}^{\infty}$ of (3.4), (3.5), (3.9), and the convergence estimate

$$(3.44) \quad \begin{aligned} & \|((u_i^n - u(x_i, t_n))_{i=0}^N)_{n=-\infty}^{\infty}\|_{X_{k,h}^{\sigma'}} \\ & \leq \text{const.} (h^2 + k + o(e^{-(\sigma-\sigma')|t_{-m}|})) \end{aligned}$$

holds as $h \rightarrow 0$, $k \rightarrow 0$, $t_{-m} \rightarrow -\infty$. The constant is independent of h , k , $\sigma' \in [\sigma_0, \sigma_1] \subset (0, \sigma)$. Moreover, (3.4), (3.5), (3.9) can be solved by the Newton procedure (going from the n th to the $(n+1)$ st time step), which is quadratically convergent from a sphere of starting values which does not shrink to a point as $h \rightarrow 0$, $k \rightarrow 0$, $t_{-m} \rightarrow -\infty$, $t_n \rightarrow +\infty$. The convergence is unconditional in the sense that h , k , t_{-m} may approach 0 (or $-\infty$ respectively) independently.

The main restriction of this theorem is the required smallness of f . However not more can be expected theoretically since the existence theory only holds for small f 's. In the next chapter we report computation using arbitrary (actually large) forces f and convergence was realized numerically for all f 's we used.

4. DISCUSSION OF NUMERICAL RESULTS

For the computations we used the same kernel as in [5]:

$$a(t) = \sum_{i=1}^8 K_i e^{-\lambda_i t}$$

with the following constants K_i, λ_i .

i	λ_i (sec ⁻¹)	K_i (Nm ⁻² sec ⁻¹)
1	10 ⁻³	1 x 10 ⁻³
2	10 ⁻²	1.8 x 10 ⁻²
3	10 ⁻¹	1.89 x 10 ⁻¹
4	1	9.8 x 10 ³
5	10	2.67 x 10 ⁵
6	10 ²	5.86 x 10 ⁶
7	10 ³	9.48 x 10 ⁷
8	10 ⁴	1.29 x 10 ⁹

These numbers were obtained by Laun [2] from an experimental fit for a polyethylene melt at 150° C, which he calls "Melt 1".

The parameter η is physically identified as a Newtonian contribution to the viscosity. Experimental values are not available, and theoretically η is either a solvent viscosity (for polymer solutions) or it results from fractions of low molecular weight (for melts). The value of η should be compared to the viscosity resulting from the memory, which, for constant shear rate, is given by $\sum_{i=1}^8 K_i \lambda_i^{-2} \approx 50000 \text{ Nm}^{-2} \text{ sec}$. One would expect η to influence the solution significantly only if it is at least comparable to this value. This heuristic argument was confirmed in [5] for the boundary

equation, and also by our present computations for the spatial problem. The numbers given in the following are understood to be in the following units:

η is given in Nm^{-2}sec .

f denotes the force acting on the ends of the filament divided by the cross-sectional area in the reference state ($u = x$). It is measured in Nm^{-2} .

ρ denotes the density of the filament multiplied by the square of half the length in the reference state (this latter scaling factor arises from the normalization of the variable x to the interval $[-1,1]$). ρ is measured in kg m^{-1} .

Time is measured in seconds. The mesh size for the following plots was 0.1 for both t and x . For plots 1-13 we chose $f = 100000 e^{-t^2/25}$ and $u(x, -\infty) = x$.

The first three plots show u , u_x and u_{xx} for $\rho = 1$, $\eta = 1$. It can be seen that u_{xx} is negligibly small, and u is almost linear in x . That means the solution is determined by the evolution of the boundary condition, and inertial forces can be neglected.

This changes, if ρ is increased. Physically, this means changing the length of the filament. For realistic values of the density, $\rho = 1$ would correspond to an initial length of a few millimeters, $\rho = 1000$ would correspond to an initial length of about 1m.

In plots 4-6, we have $\rho = 1000$, $\eta = 1$. Three-dimensional plots of u and u_{xx} and sections of u_x at various times are shown. It can be seen that u_{xx} has increased by a factor of 1000 compared to the previous plots. Otherwise the qualitative behaviour remains roughly the same.

The next three plots were made for the same ρ and $\eta = 100000$ (for $0 < \eta < 100000$, the solutions changed very little). In comparison to $\eta = 1$,

it was found here that the boundary value for u_x increases more slowly up to $t = -2$ and then increases rather suddenly around $t = 0$. In this region inertial forces become very important, a fact manifested in the plots by a rather pronounced spike in u_{xx} .

In figure 10 we have $\rho = 1000$, $\eta = 1000000$. In this case the behaviour becomes almost Newtonian, and there is hardly any elastic recovery (the maximal value for $u(x=1)$ is 1.404, the value at $t = 60$ is still 1.398). The dependence of u on x is again almost linear.

Several calculations were done for $\rho = 10000$. Figures 11-13 show u , u_x and u_{xx} for $\eta = 100000$. It can be seen that u_{xx} becomes rather large. When one looks carefully at the plots for u , one also finds that a little "overshoot" occurs in the relaxation: Whereas in the previous plots u decreased monotonically after reaching the maximal value, this is no longer true here:

	$t = 6$	$t = 8$	$t = 10$	$t = 12$
$u(x=-1)$	-83.6	-22.7	-3.8	-4.3

If smaller values of η are chosen, this "overshoot" becomes even more pronounced. The mesh size becomes very crucial here; if it is chosen too coarse, then the numerical approximation to u_x changes sign in finite time. This effect could not be reproduced with a finer mesh, although the values agree very well before one gets near this "critical" point.

For the next three plots we have chosen an "oscillating" force: $f = 0$ for $t < -20$ and $f = 20000 \cdot e^{-t^2/625} (1 + \cos \frac{t}{2})$ for $t > -20$. The values $\rho = 1000$, $\eta = 100000$ were chosen. The solution seems to "follow" the oscillations with a certain time lag (cf. [5]).

In plots 17-31 we are concerned with filaments which are not in the reference state $u = x$ at $t = -\infty$, but rather in an already deformed state. In all cases we have chosen $f = 100\,000 e^{-t^2/25}$. In figures 17-19, we have $u(x, -\infty) = x + x^3$, corresponding to a filament which becomes thinner towards the ends. The parameters $\rho = 1000$, $\eta = 1$ were chosen. Observe, in particular, that the recovery of u shows several oscillations here.

The last twelve plots have the same f and $u(x, -\infty) = x - \frac{x^2}{4}$, representing a filament that is thinner towards the left. In figures 20-25, we have $\rho = 1$, $\eta = 1$, in the second series of figures (26-31), we have $\rho = 10000$, $\eta = 100000$. The qualitative behaviour changes considerably, and, in particular, the effect of inertia is very important.

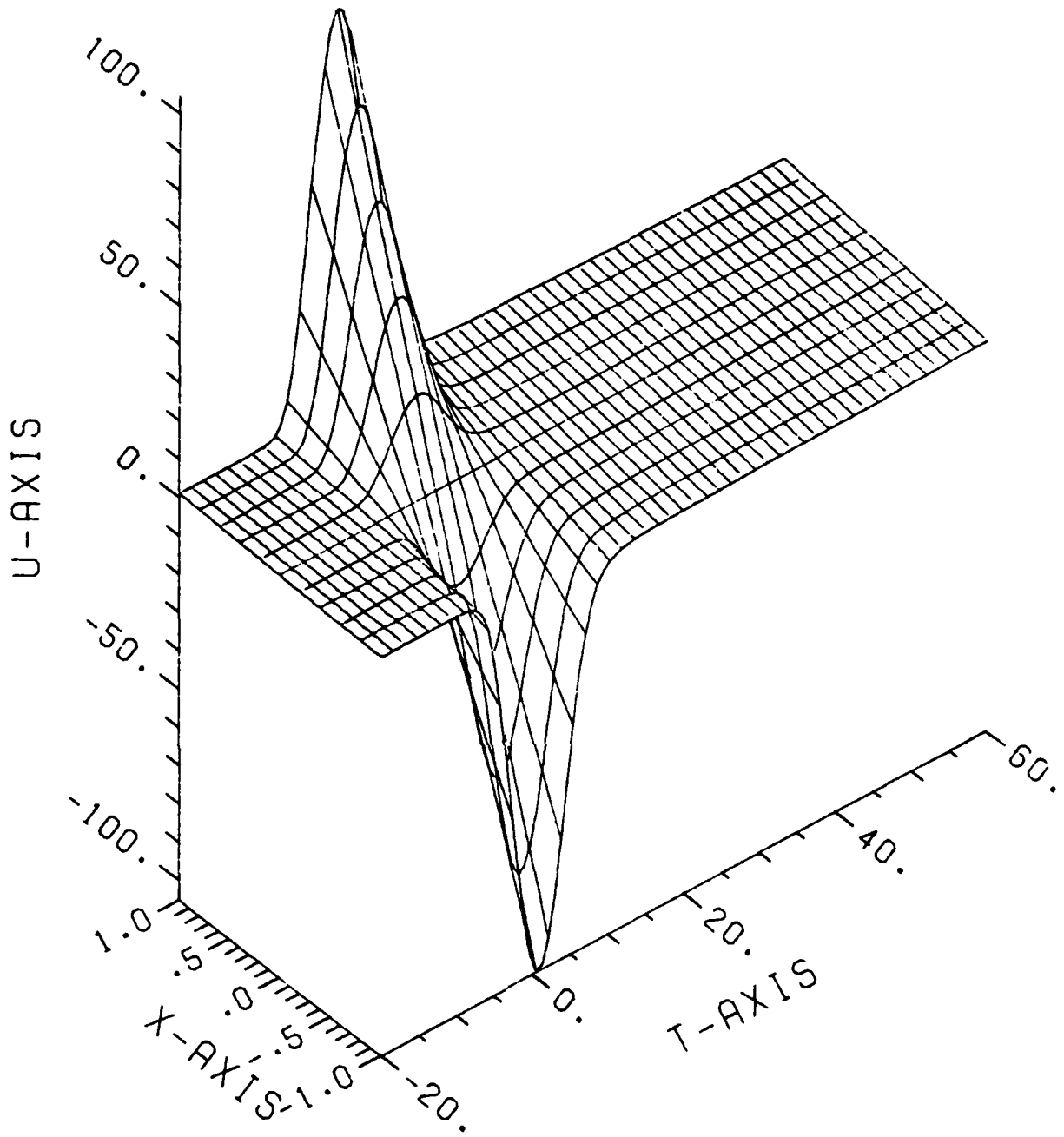

U

Figure 1

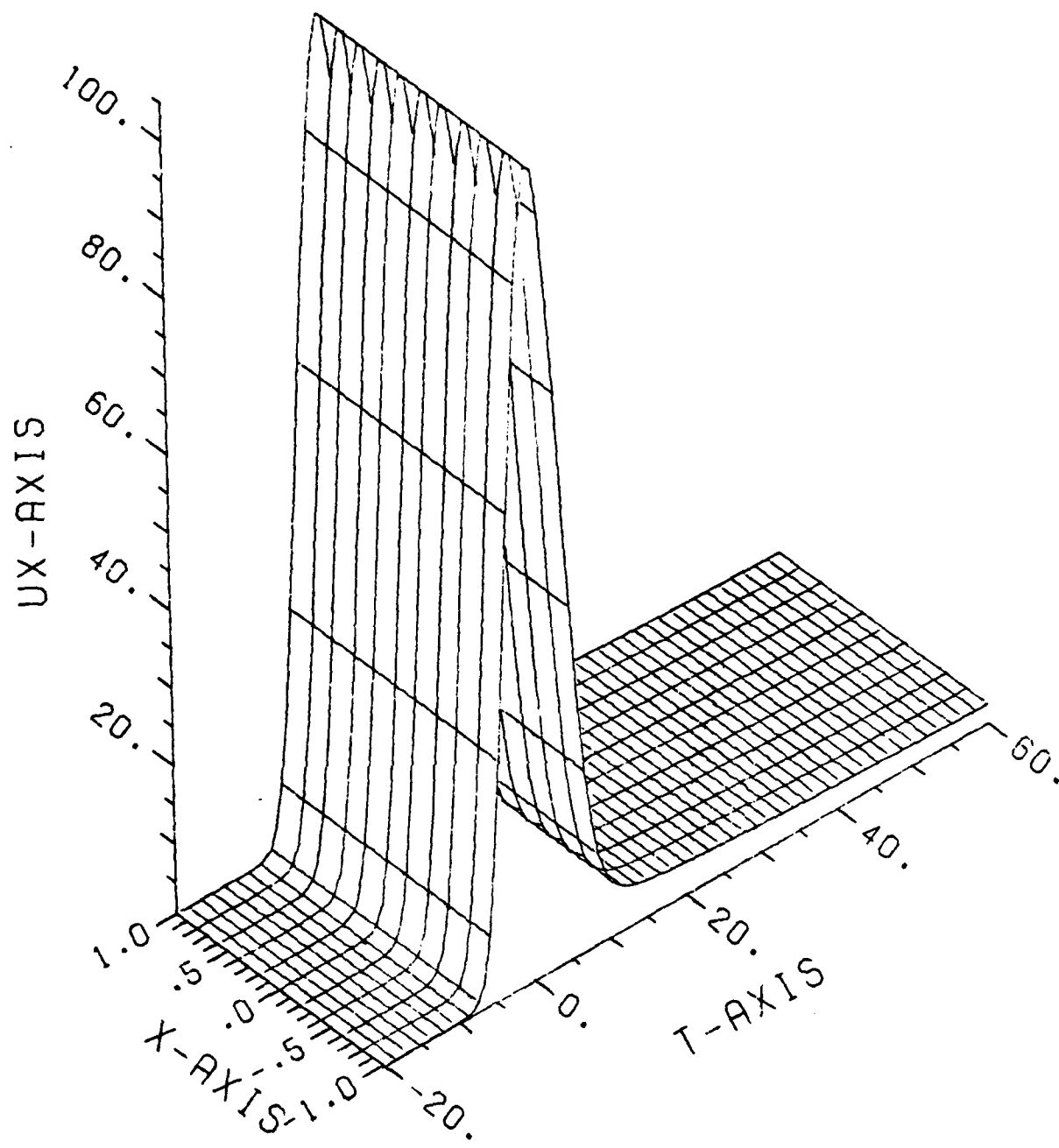

UX

Figure 2

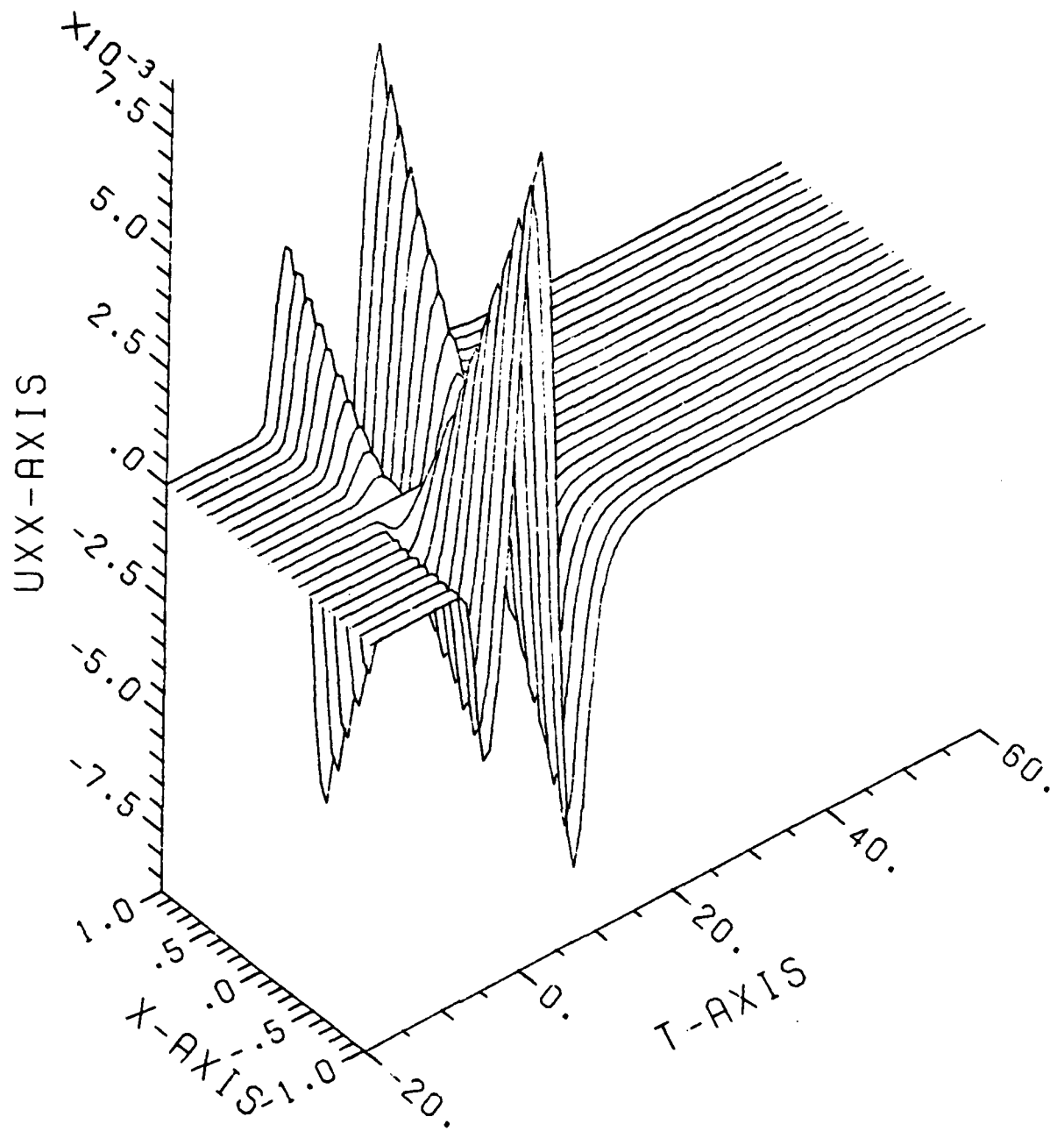

UXX

Figure 3

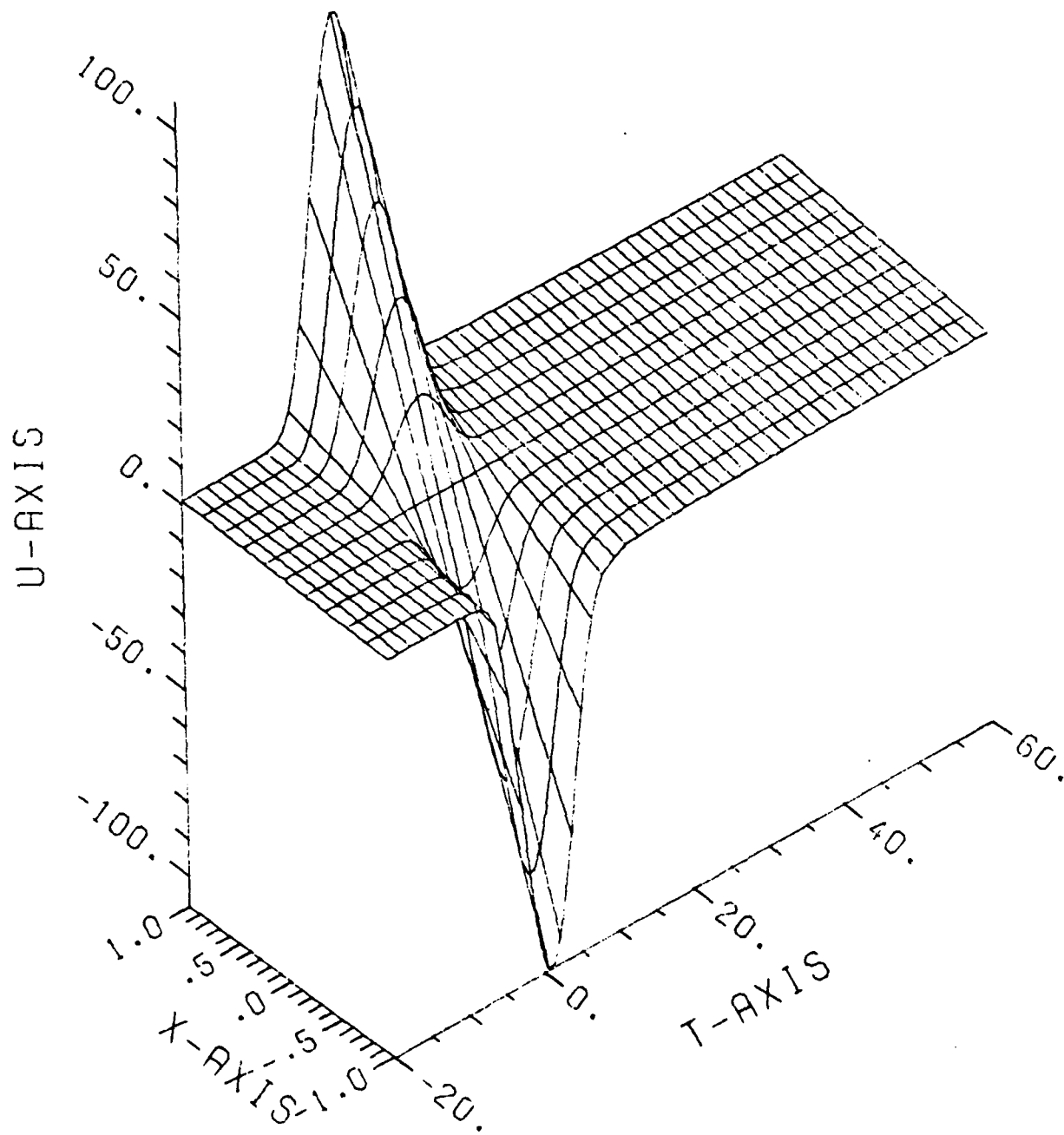

U

Figure 4

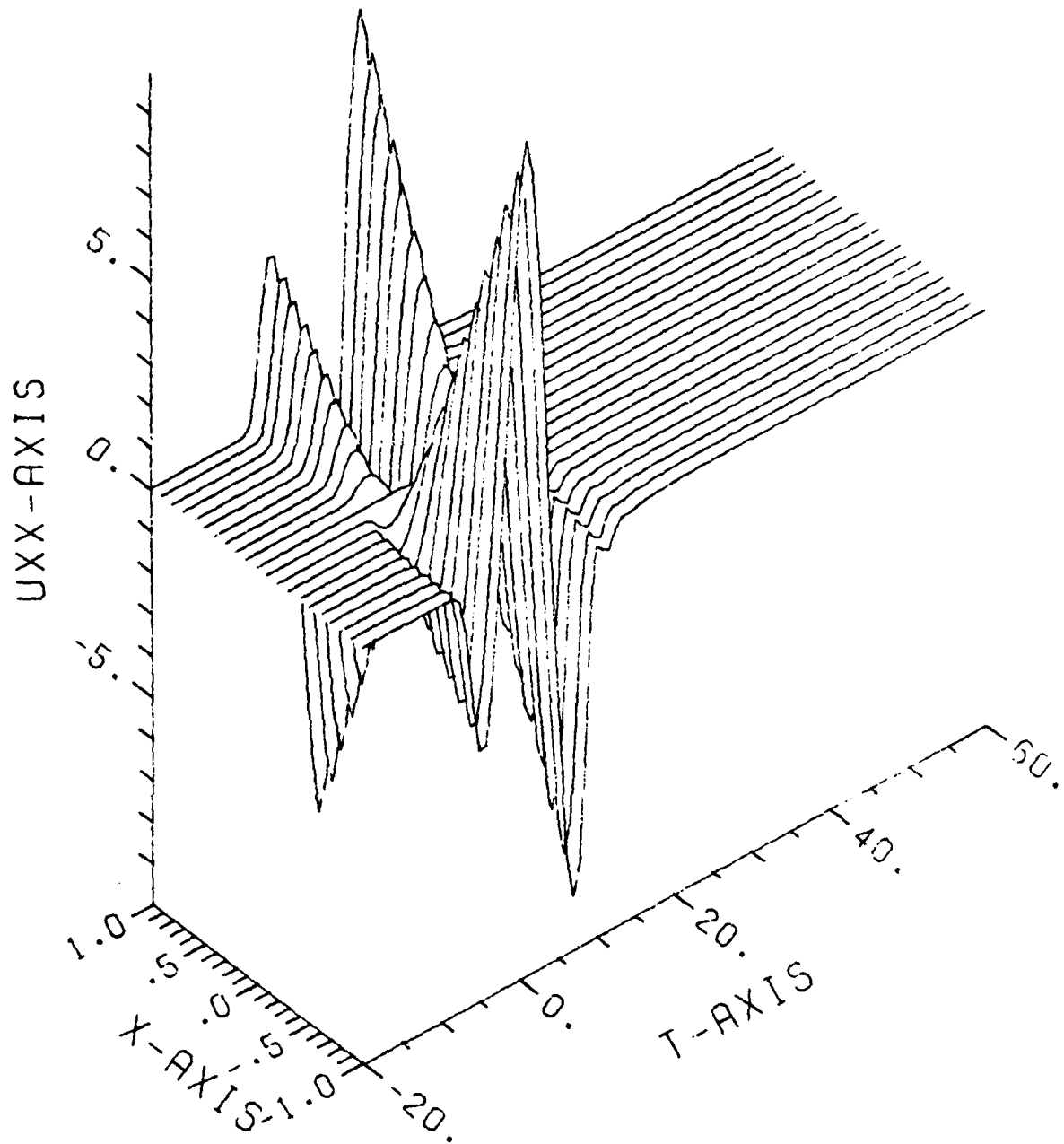

UXX

Figure 5

UX-SECTIONS

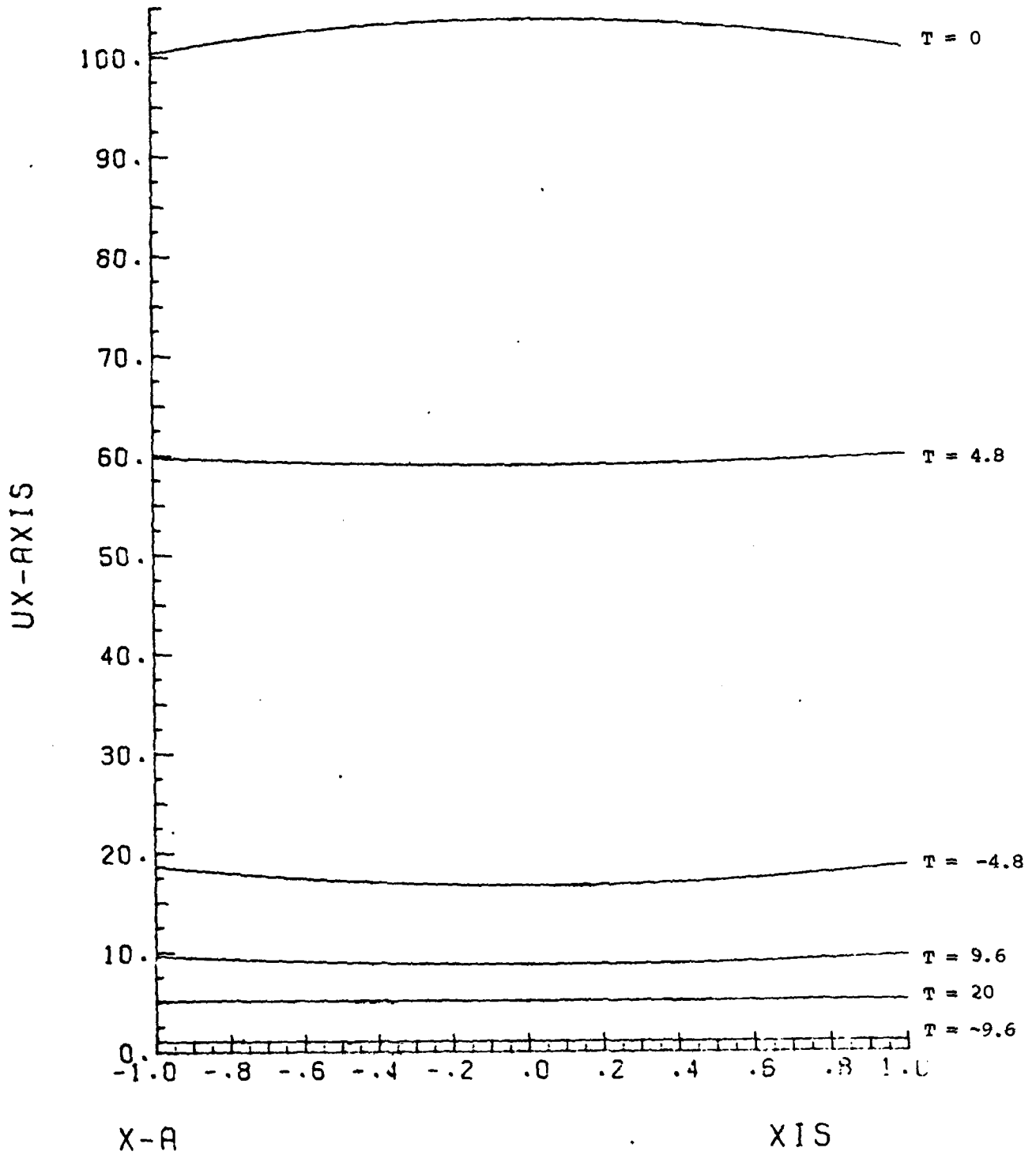
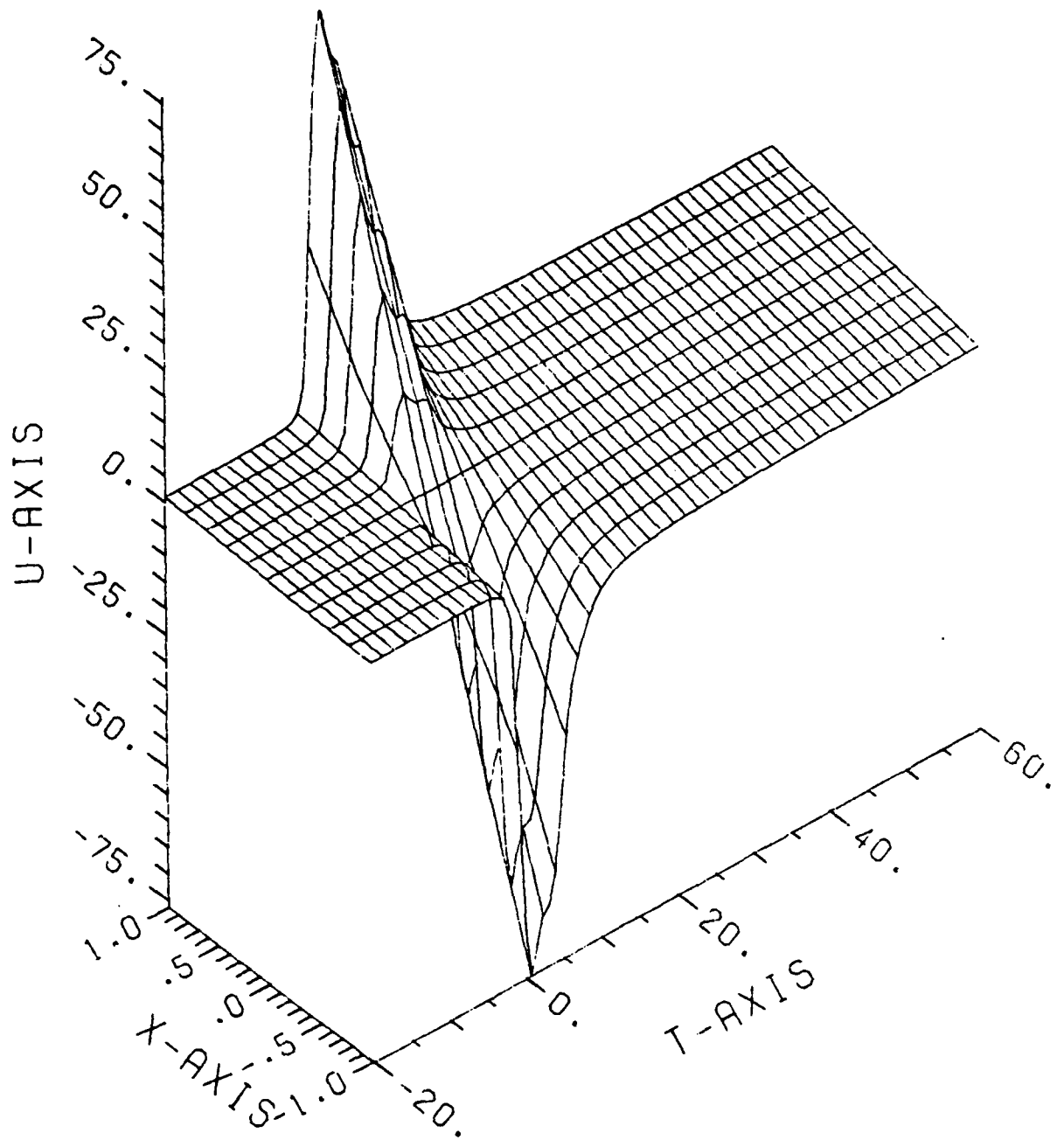
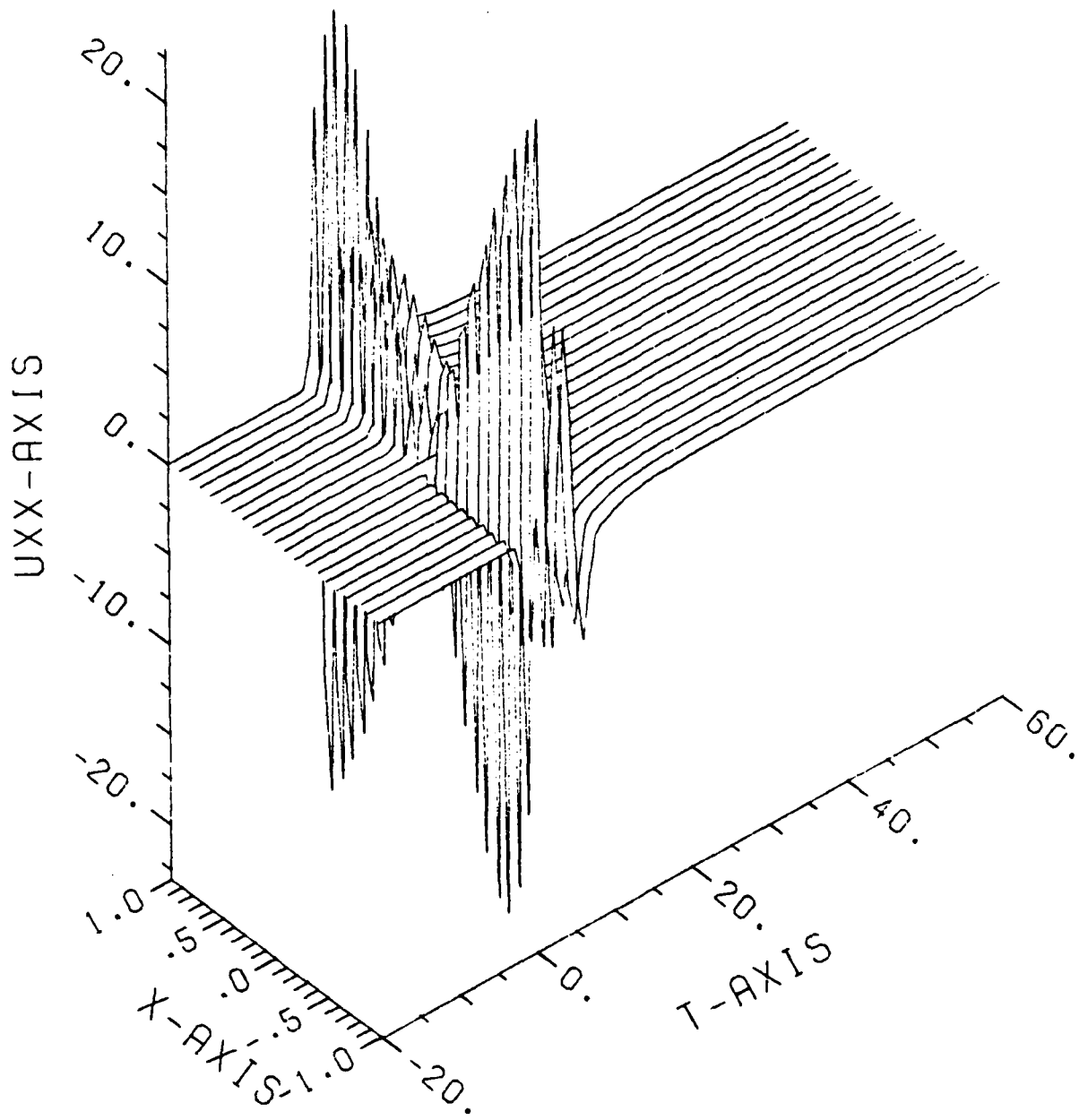

Figure 6



U

Figure 7



UXX

Figure 8

UX-SECTIONS

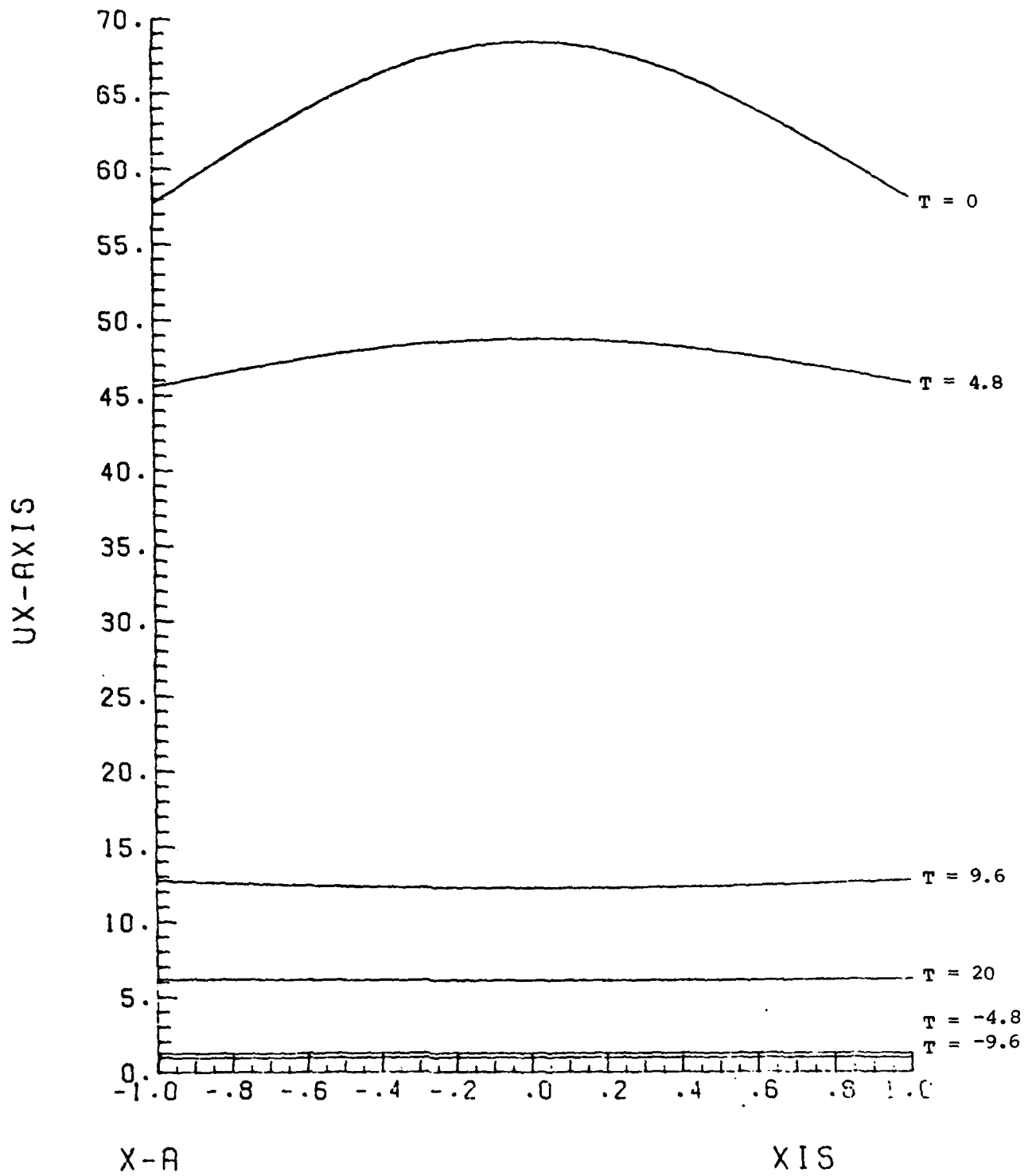
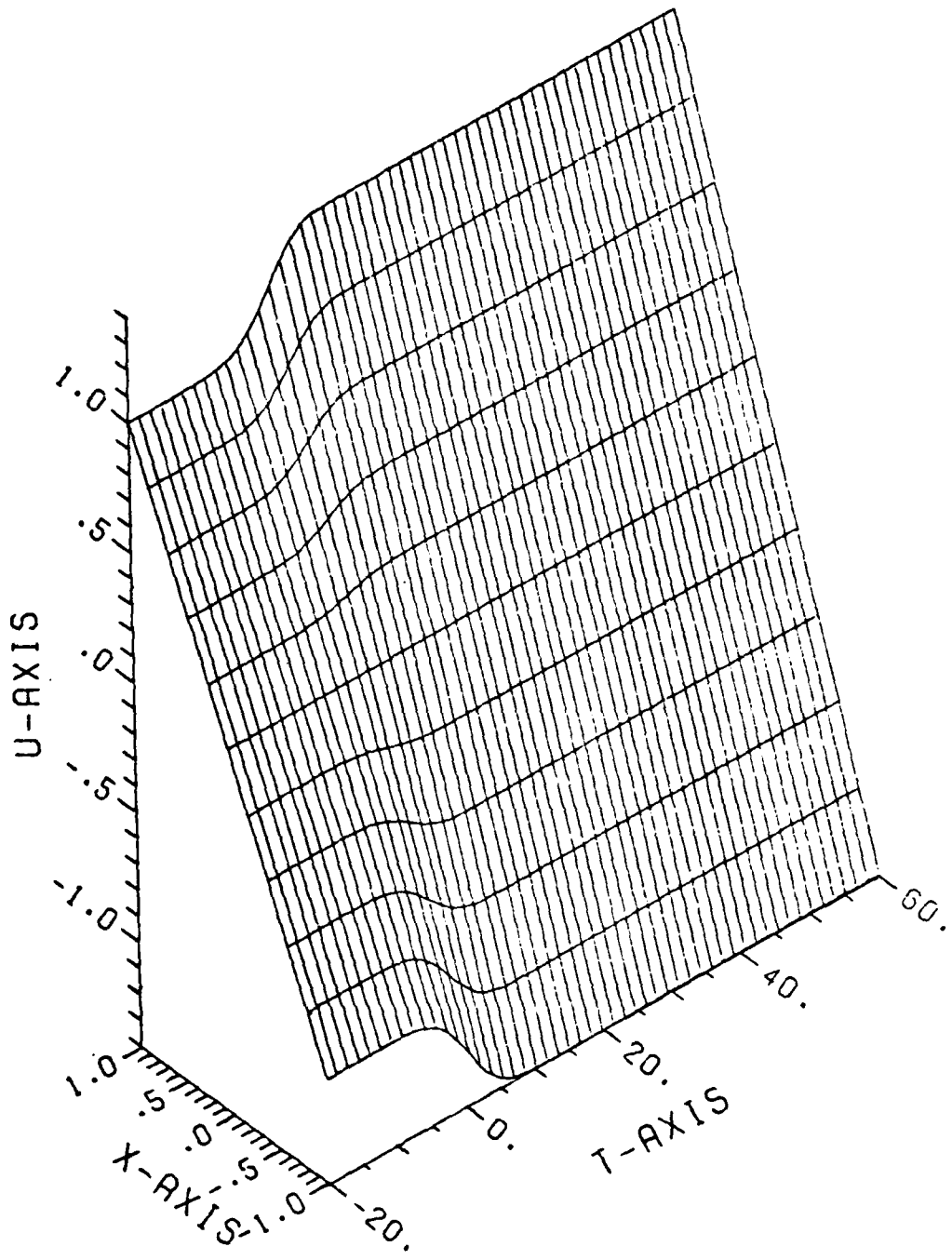
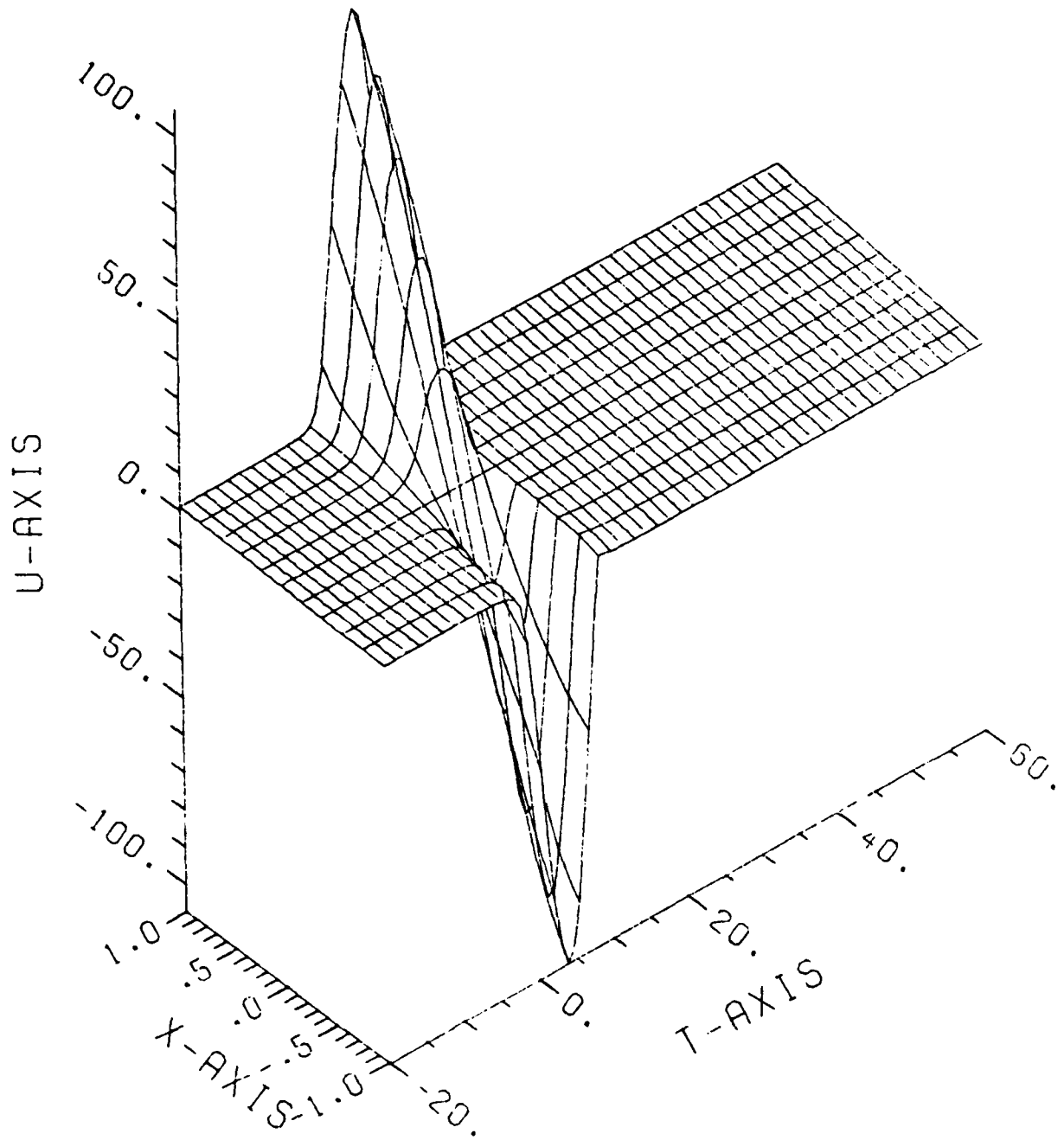

Figure 9



U

Figure 10



U

Figure 11

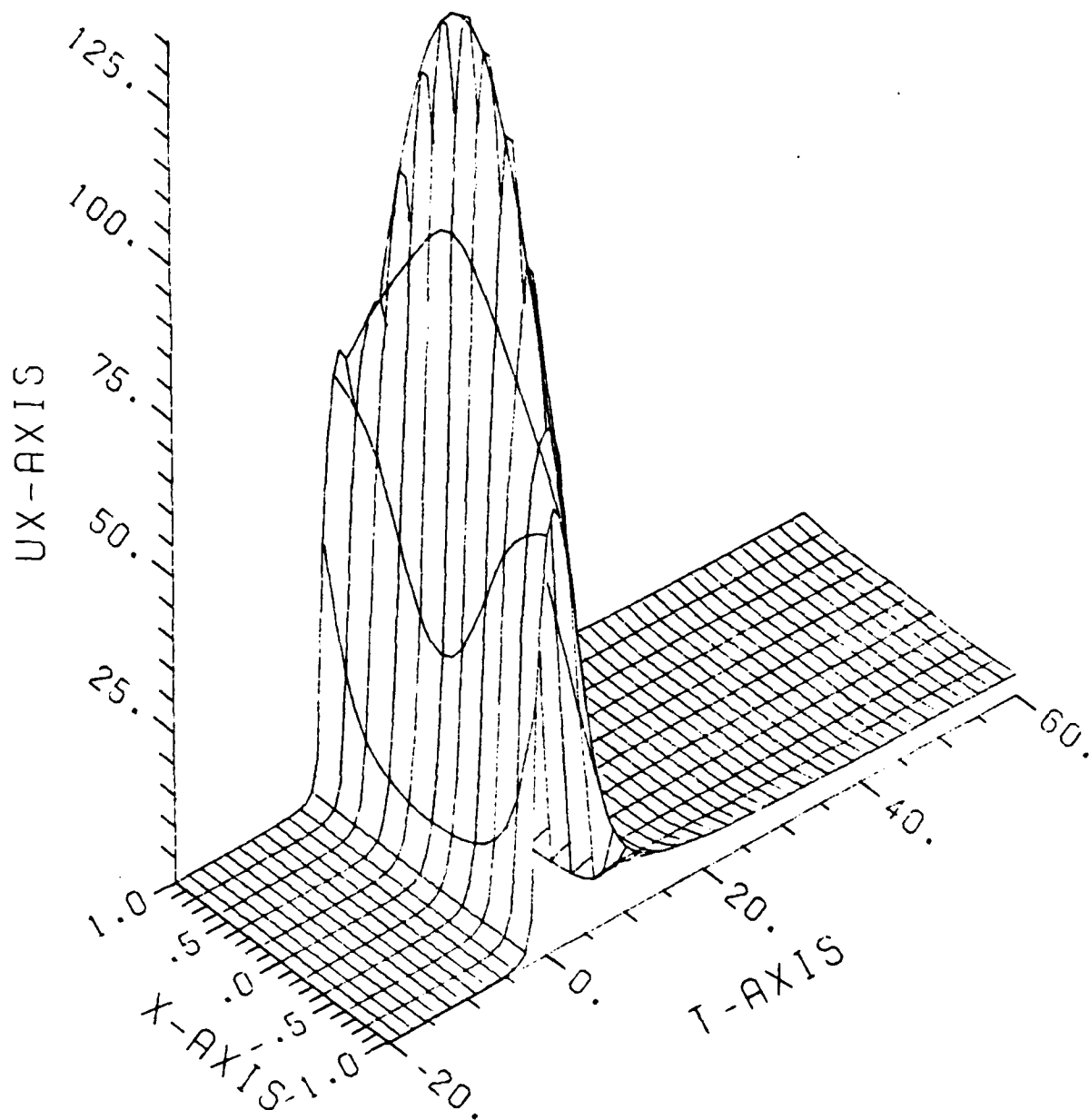

UX

Figure 12

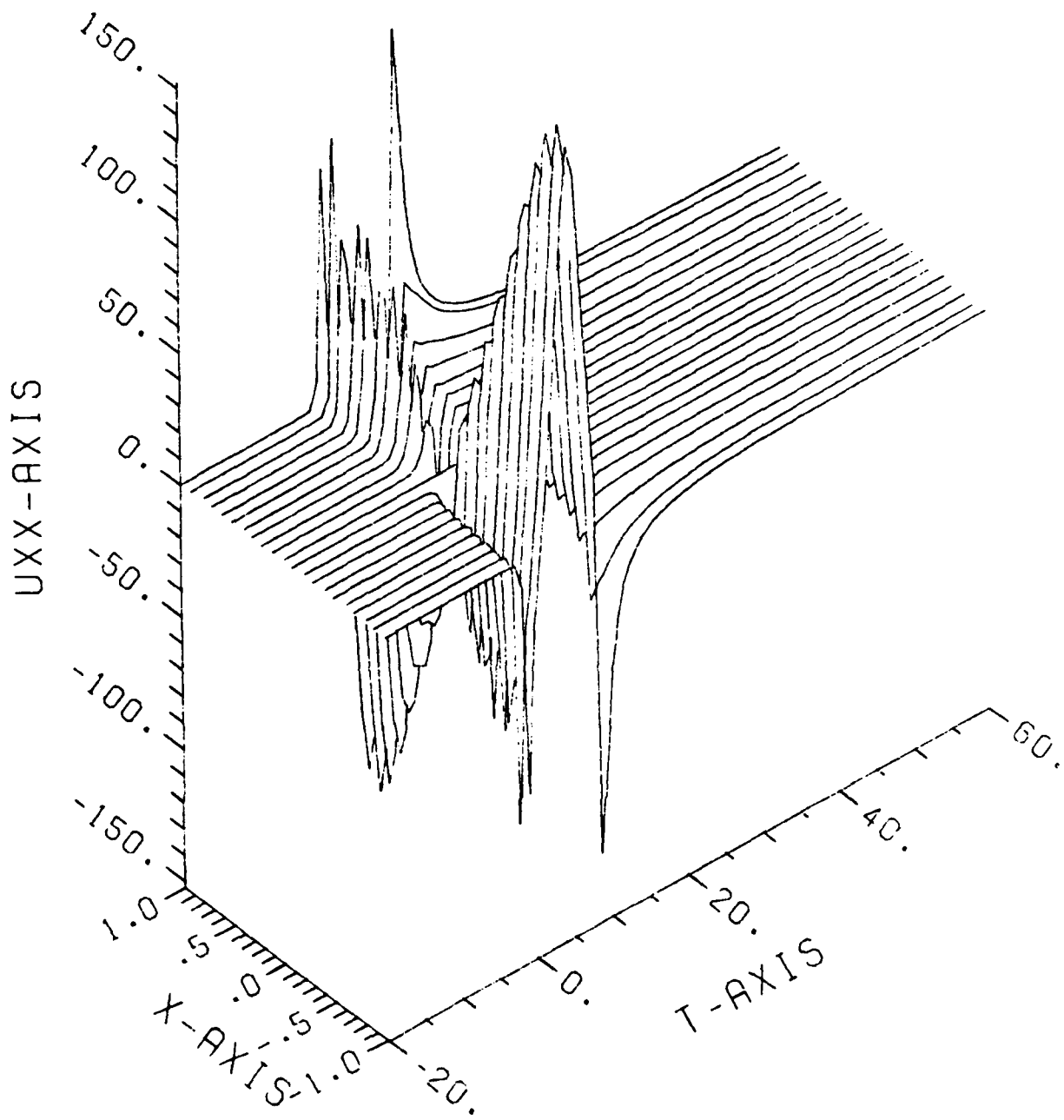

UXX

Figure 13

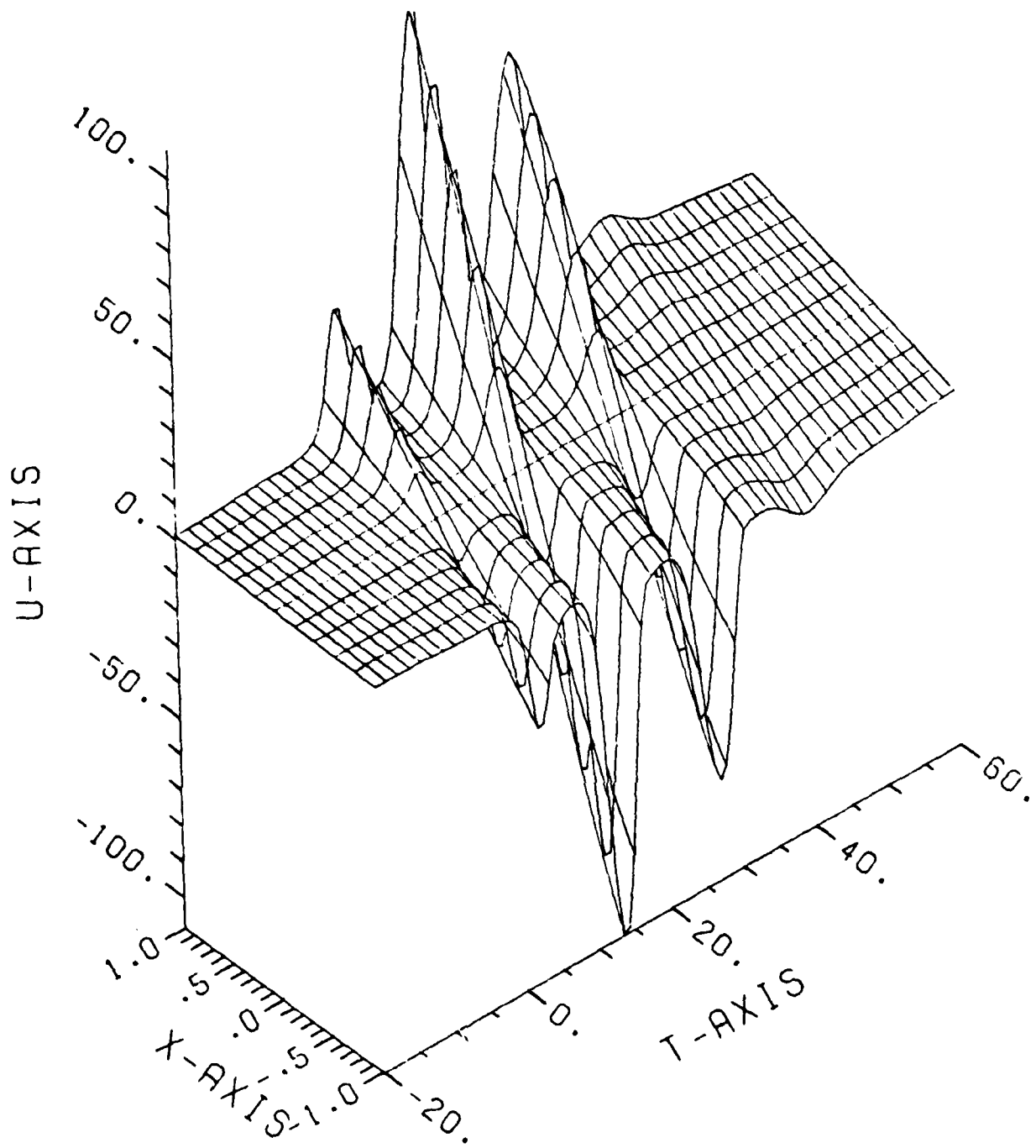

U

Figure 14

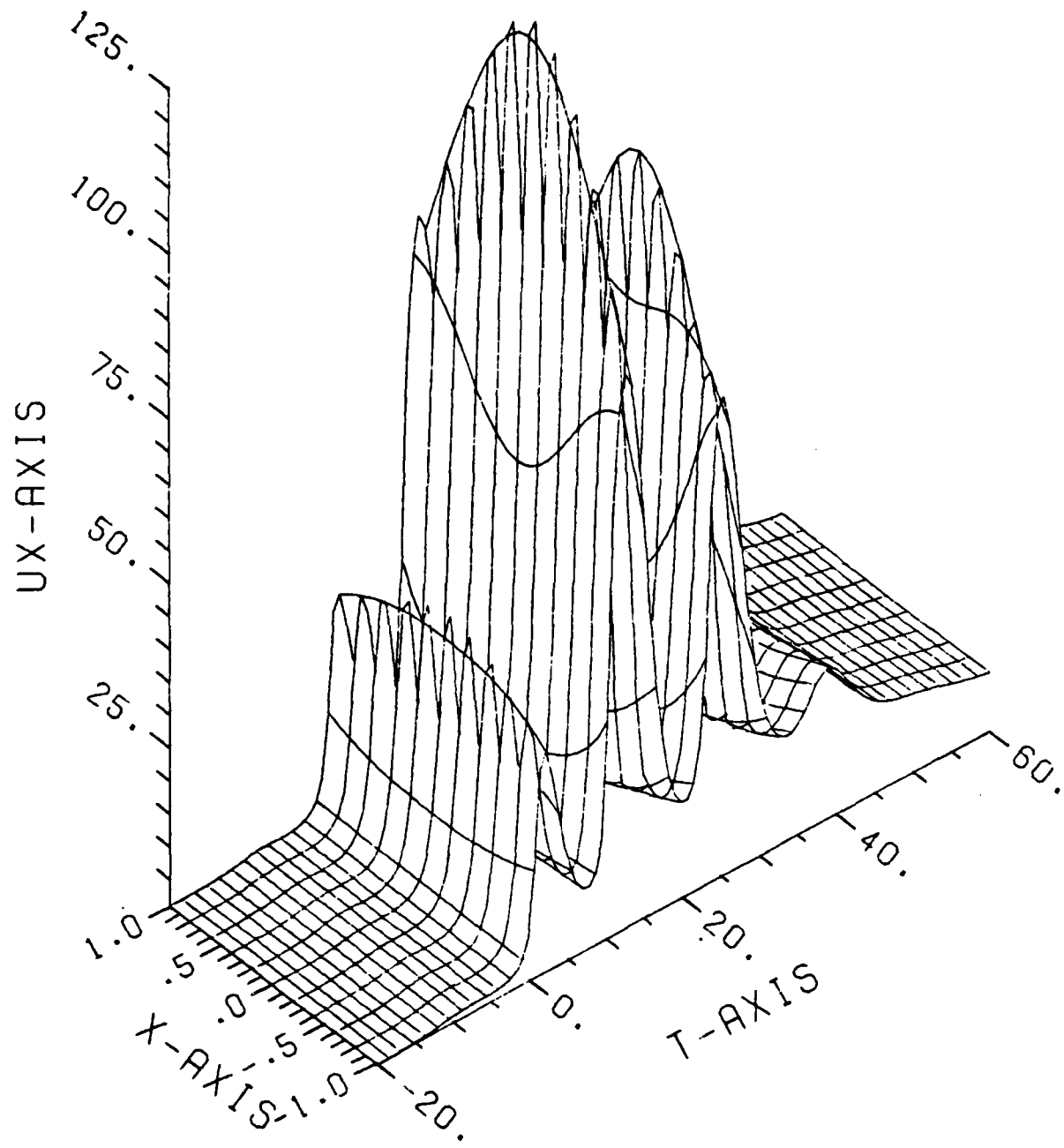

UX

Figure 15

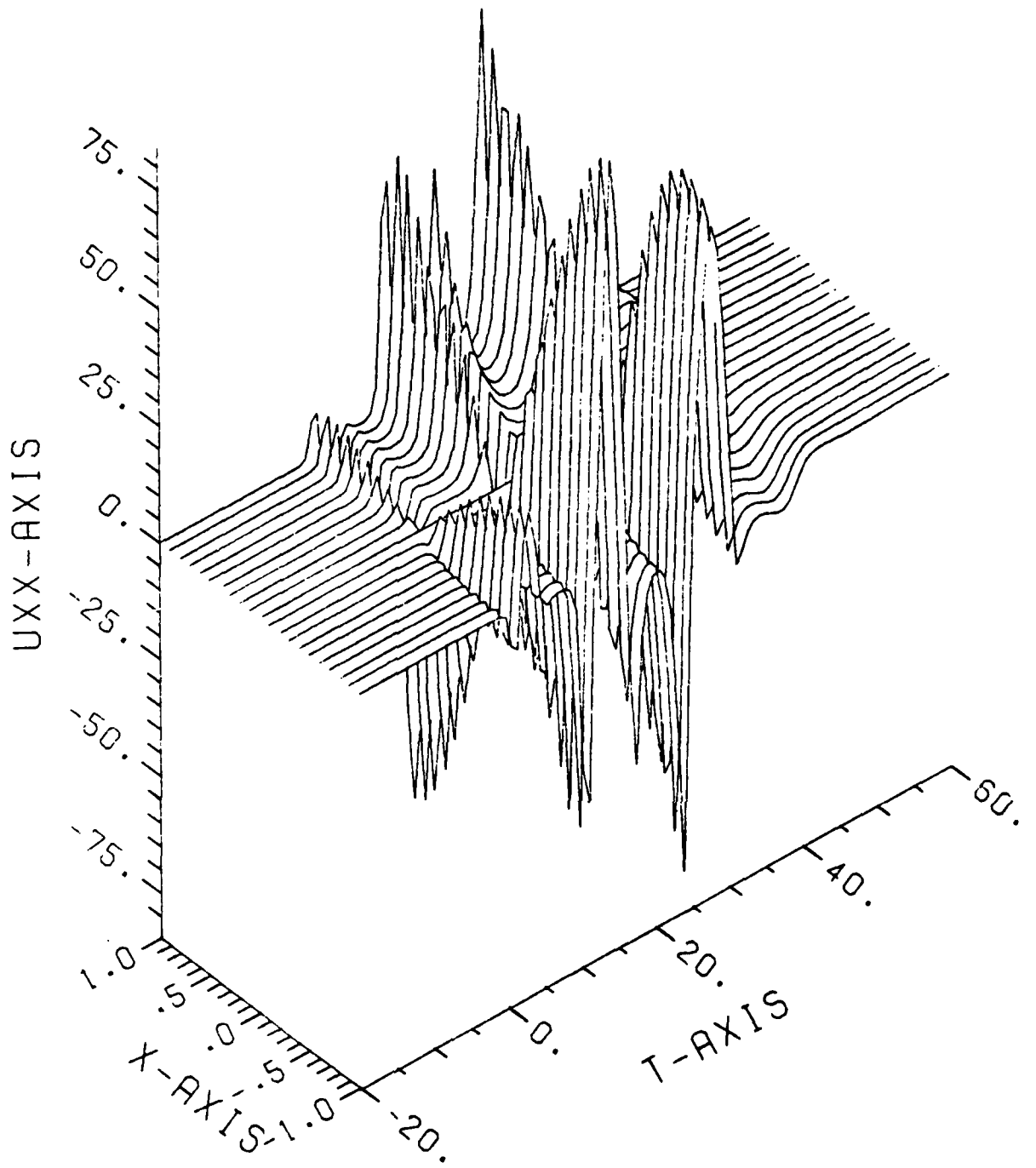

UXX

Figure 16

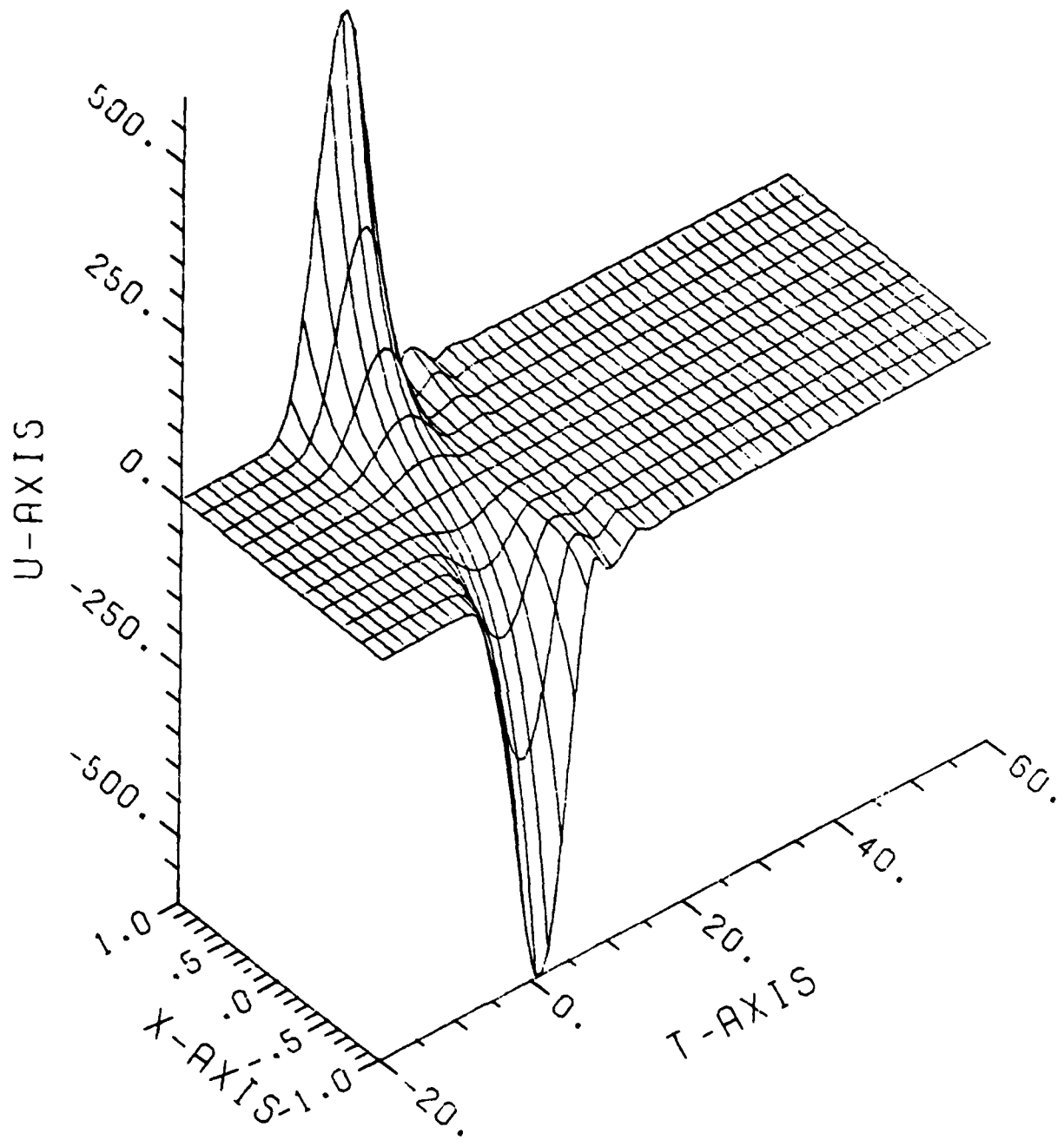

U

Figure 17

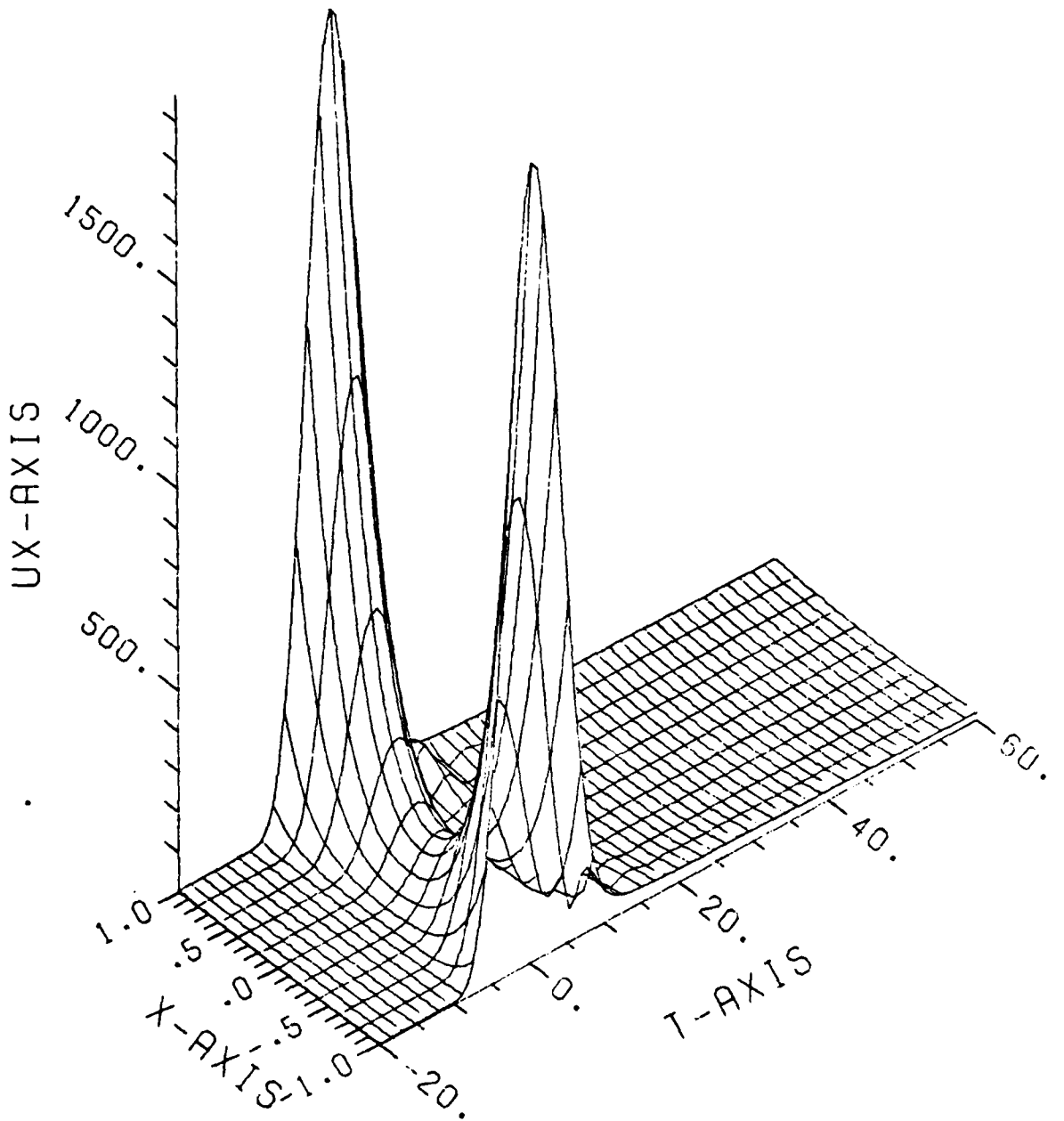

.UX

Figure 18

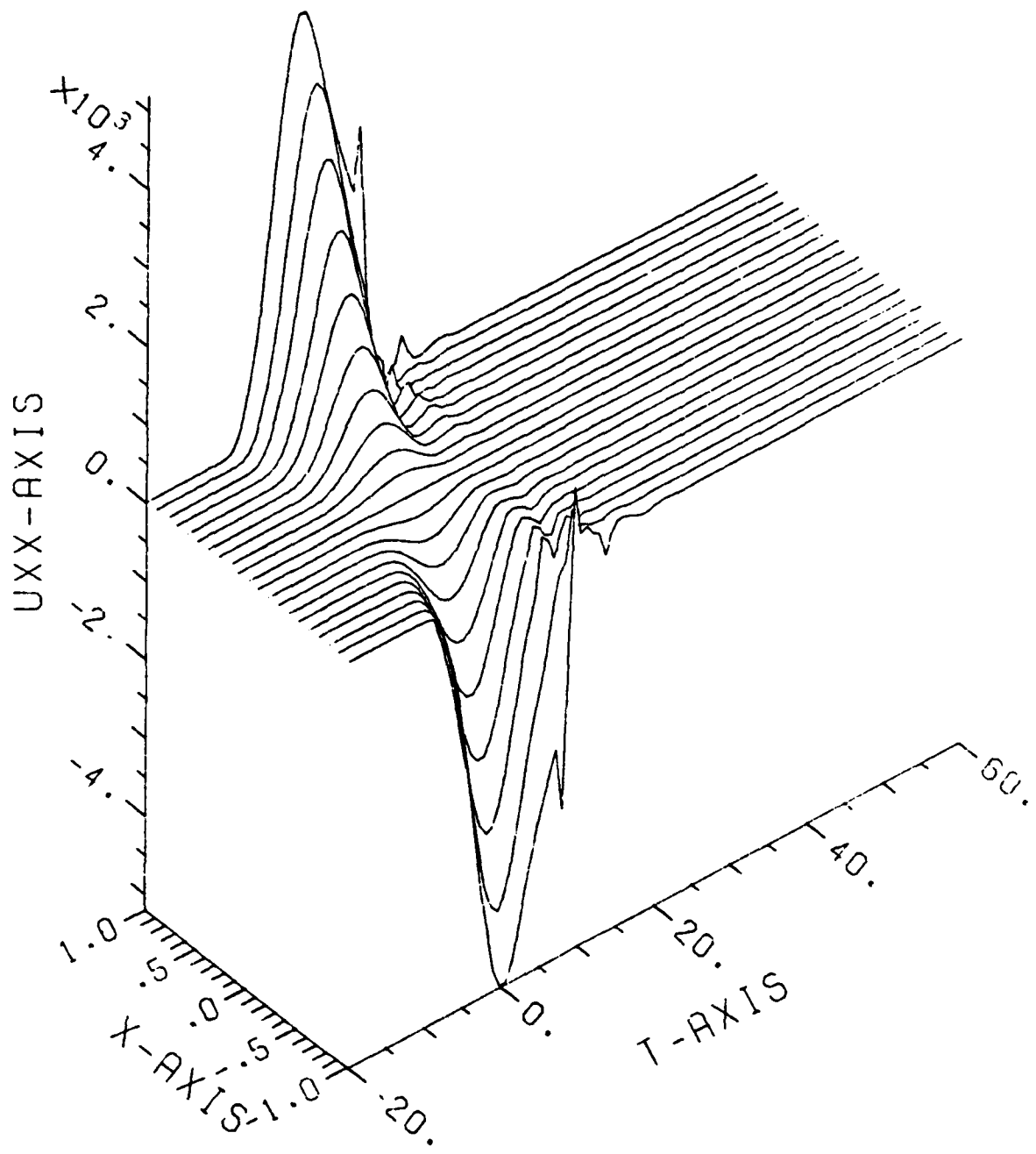

UXX

Figure 19

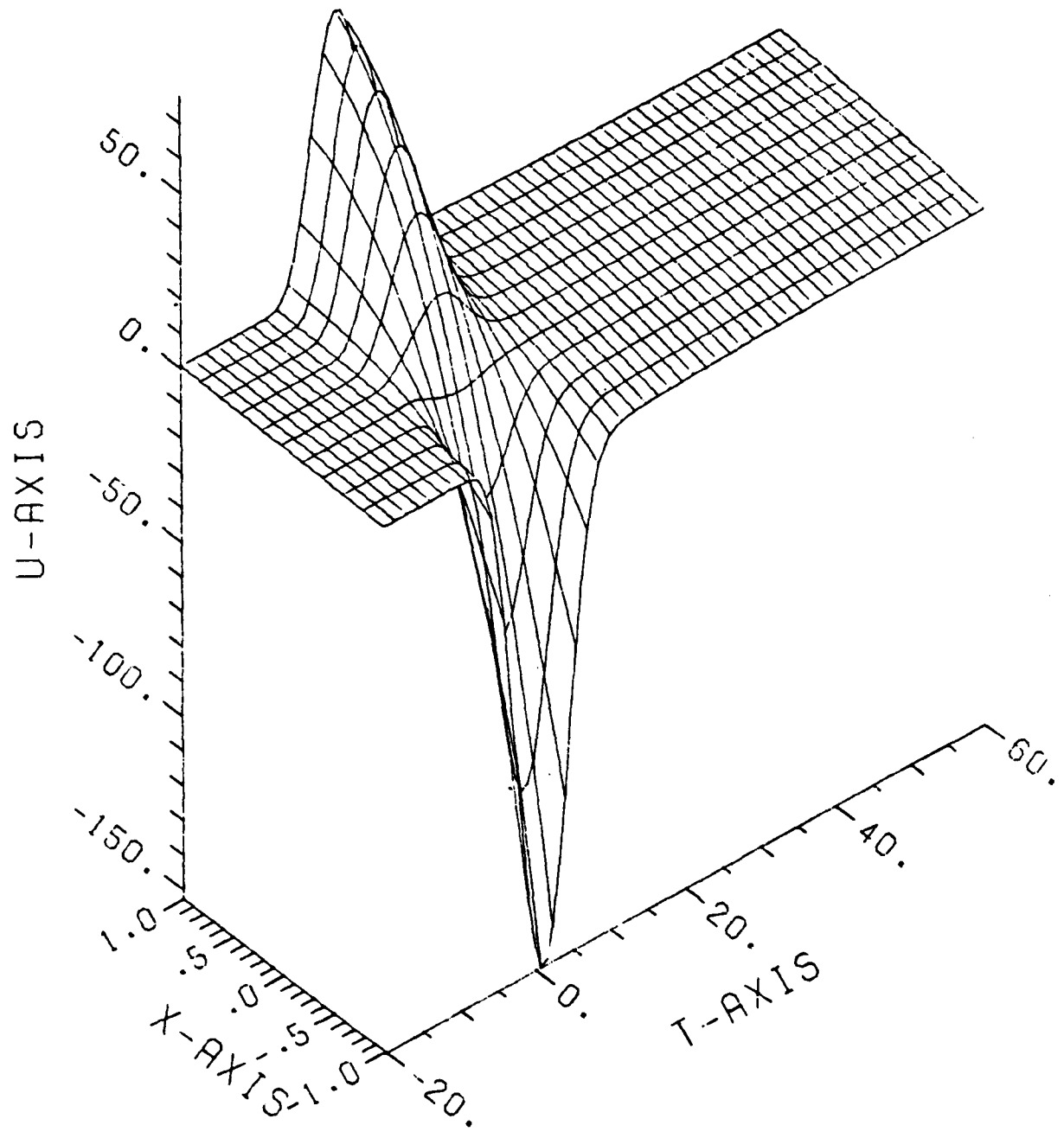

U

Figure 20

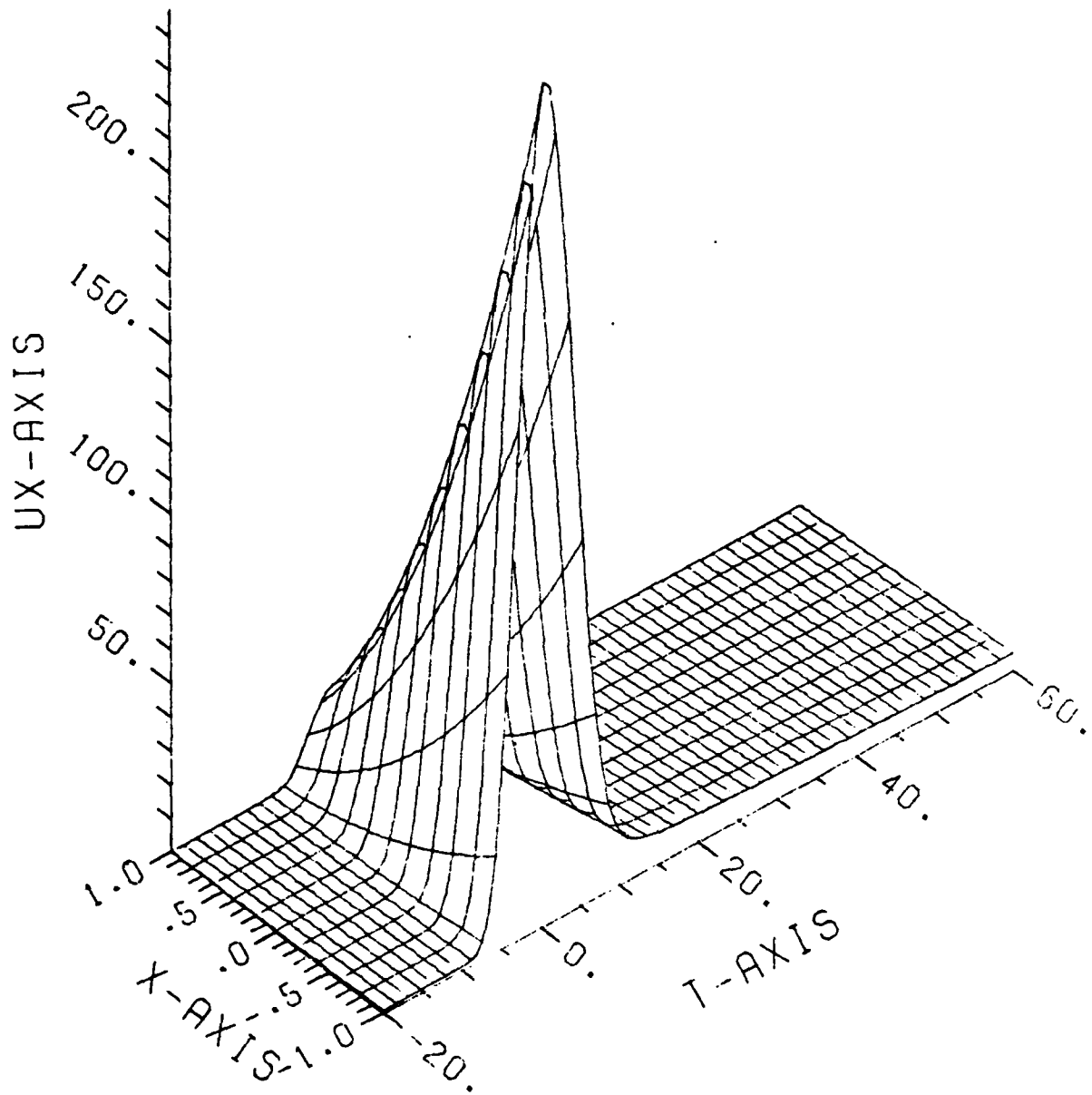

UX

Figure 21

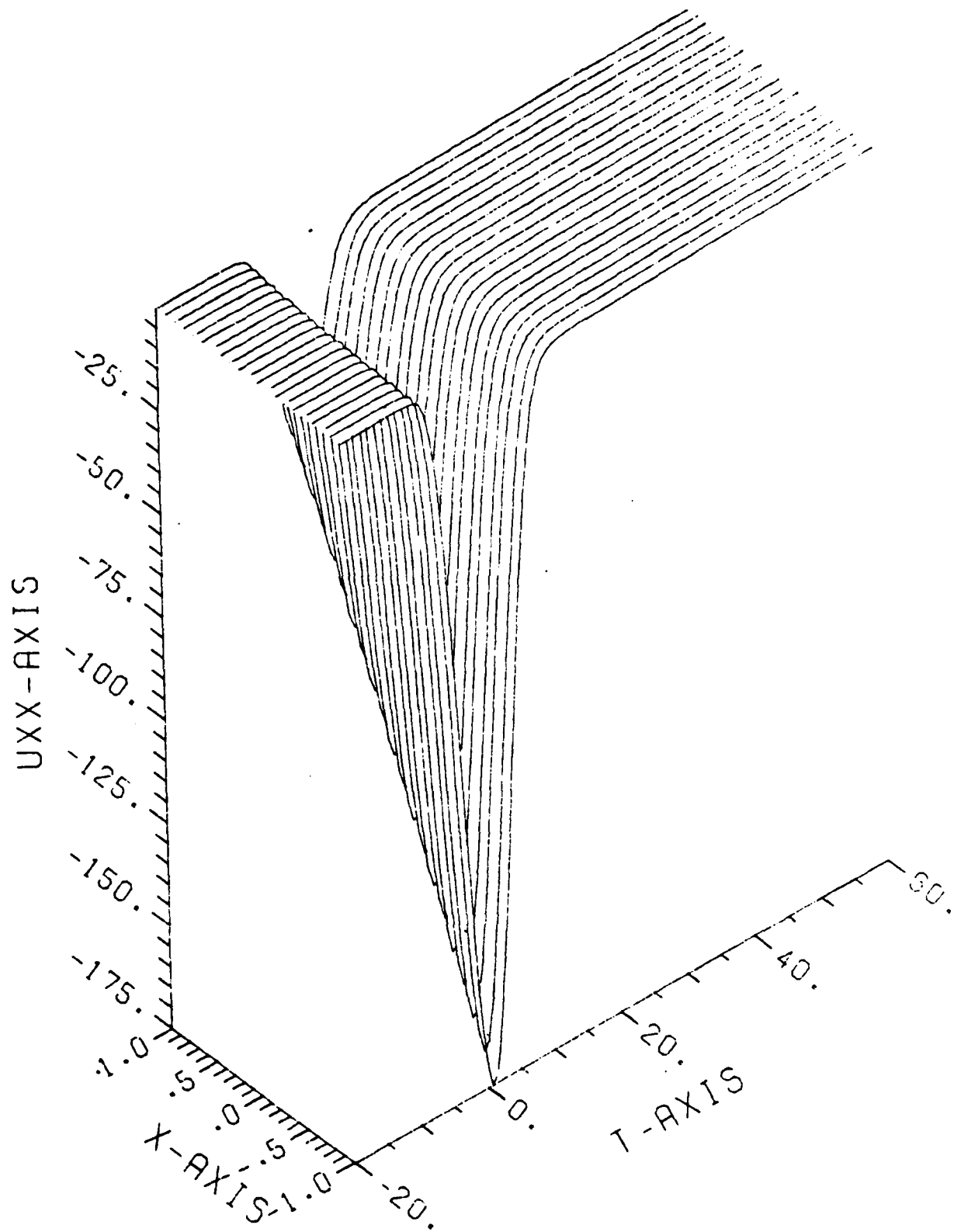

UXX

Figure 22

U-SECTIONS

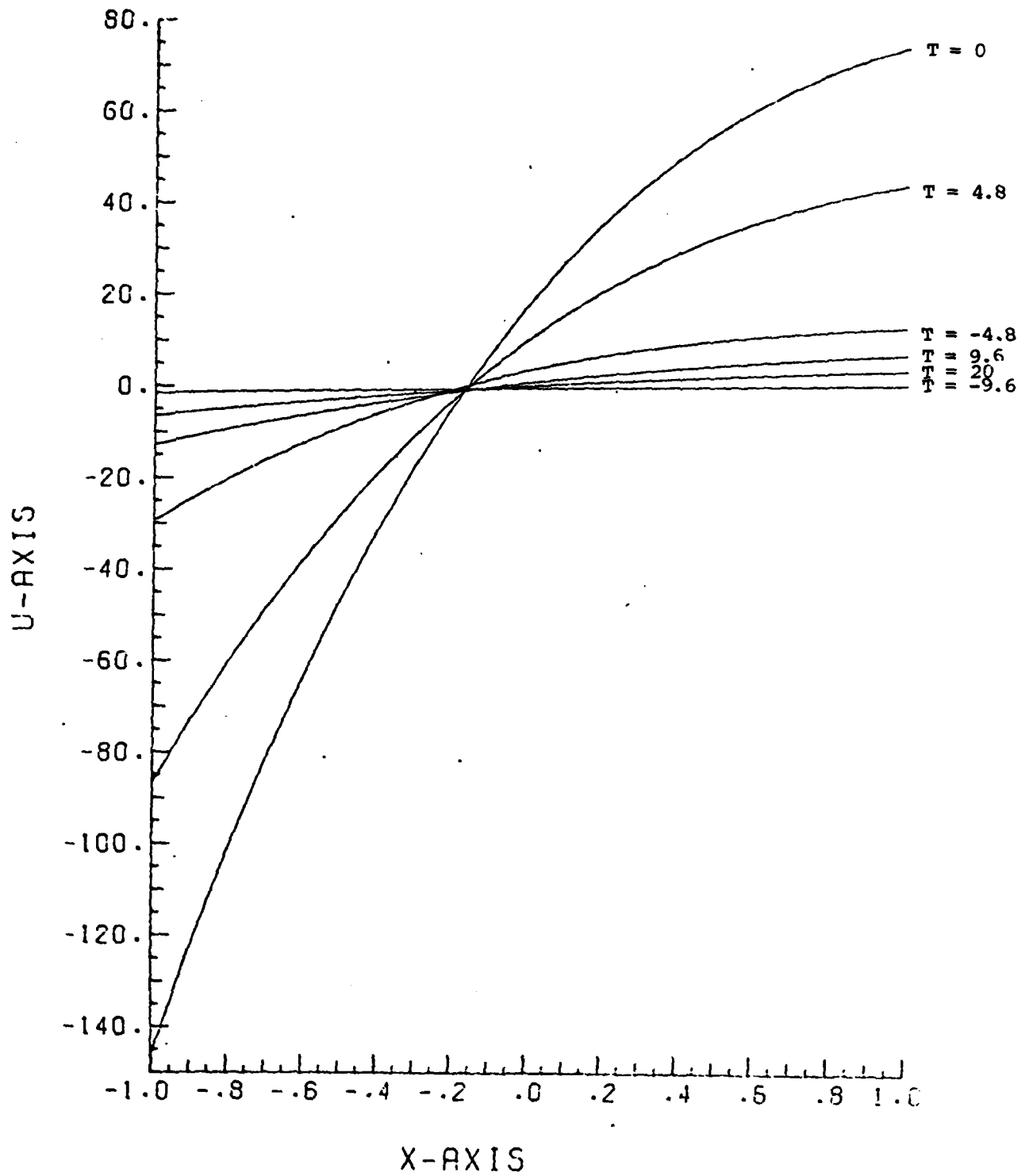

Figure 23

UX-SECTIONS

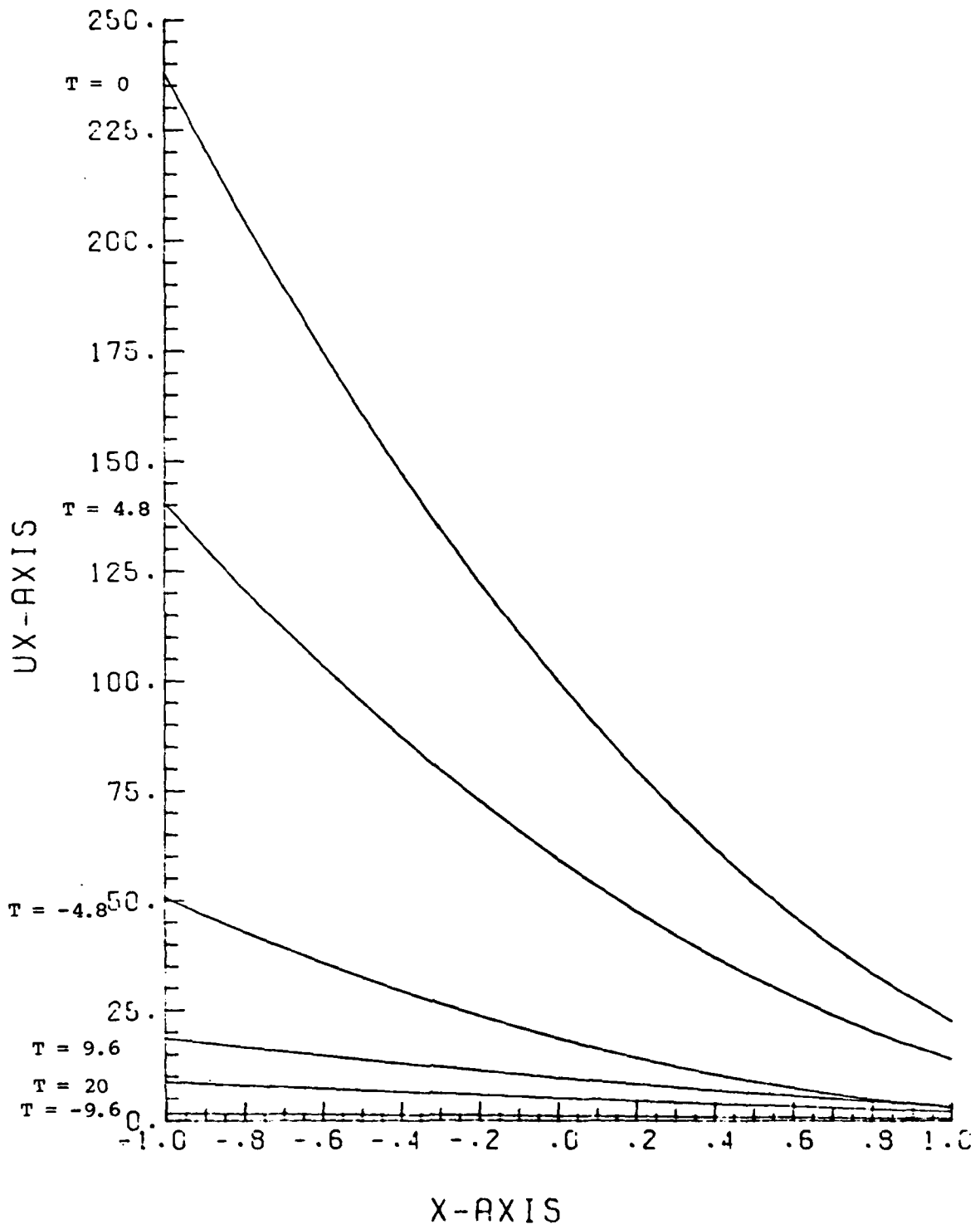

Figure 24

UXX-SECTIONS

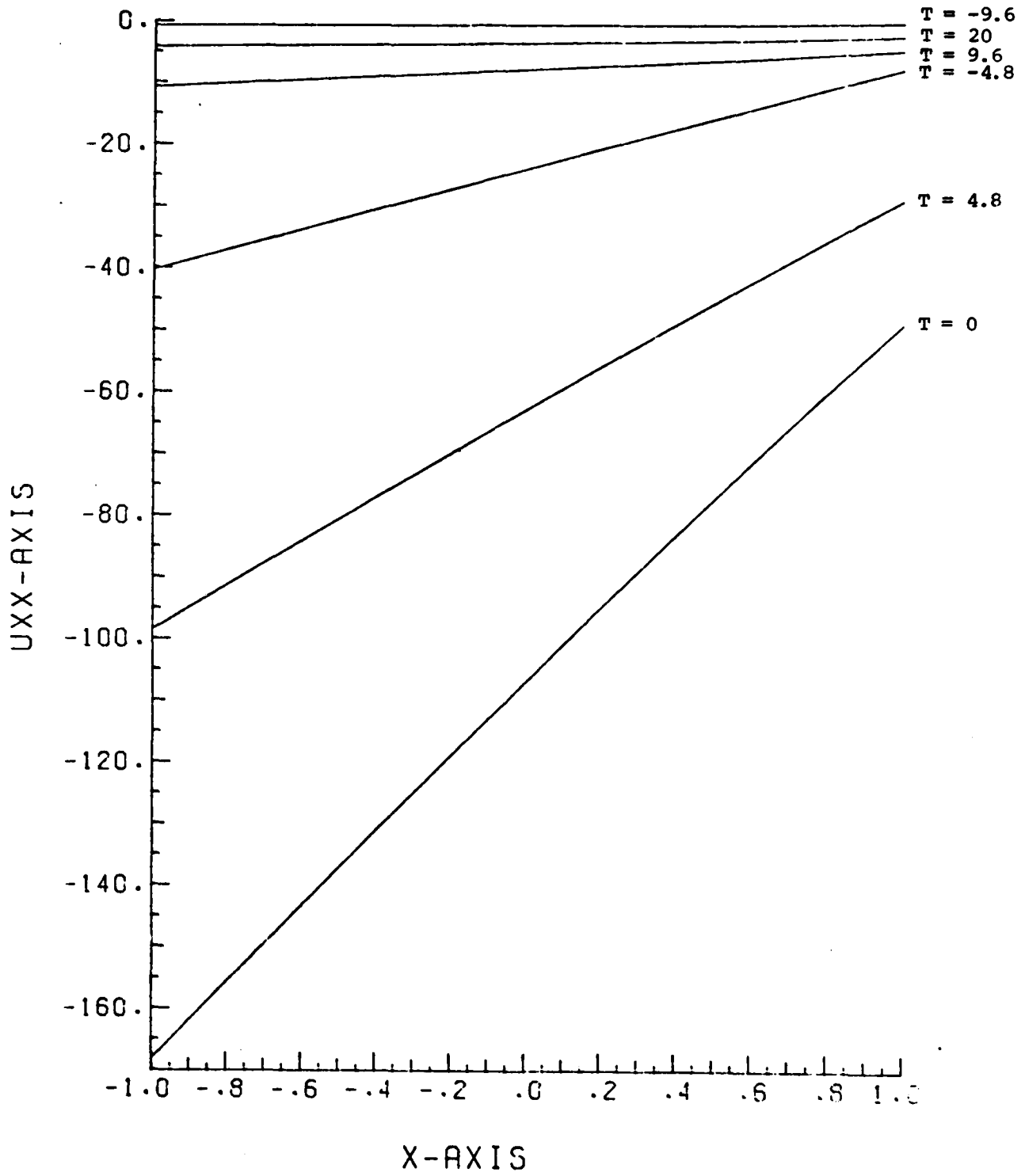
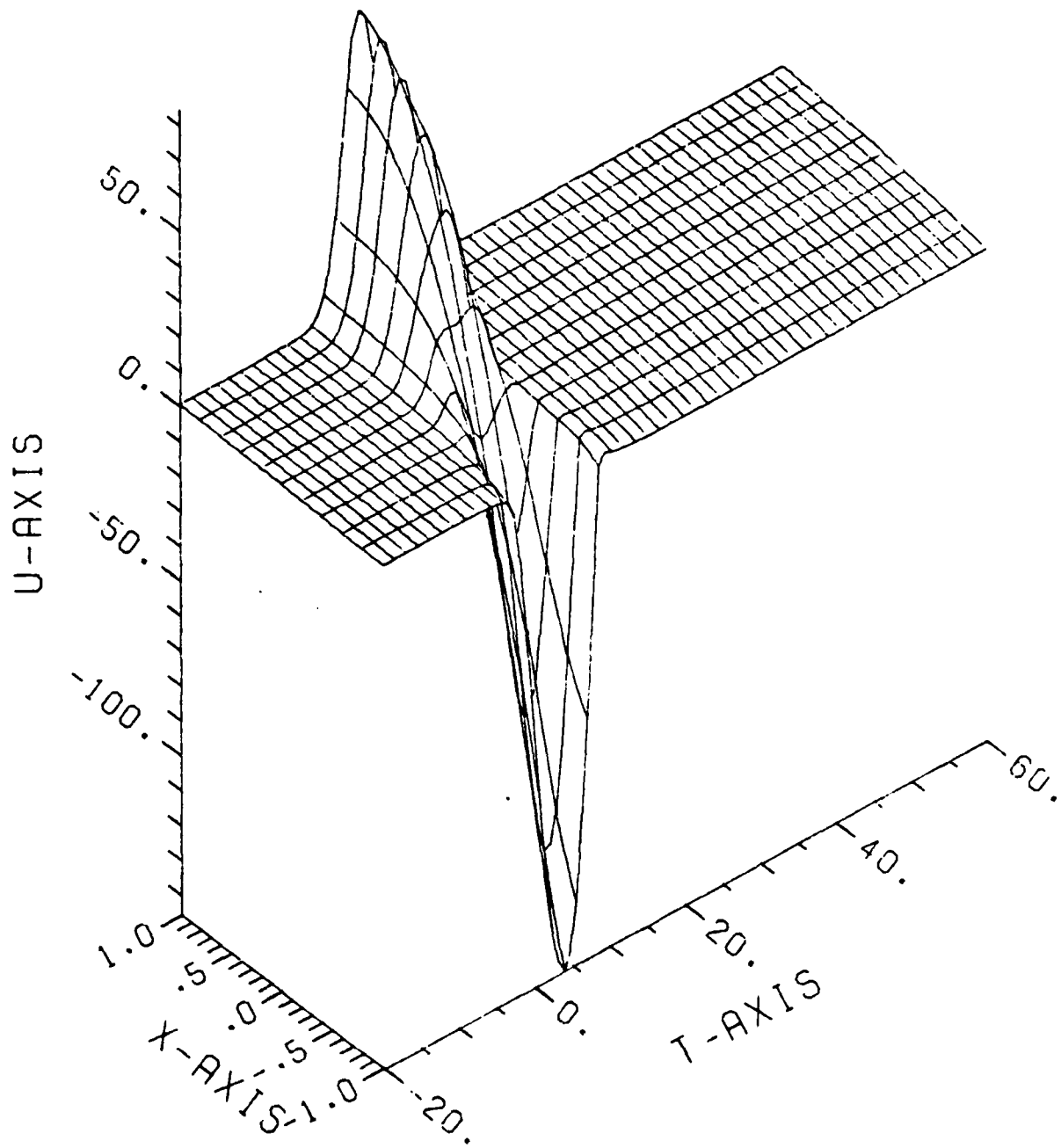
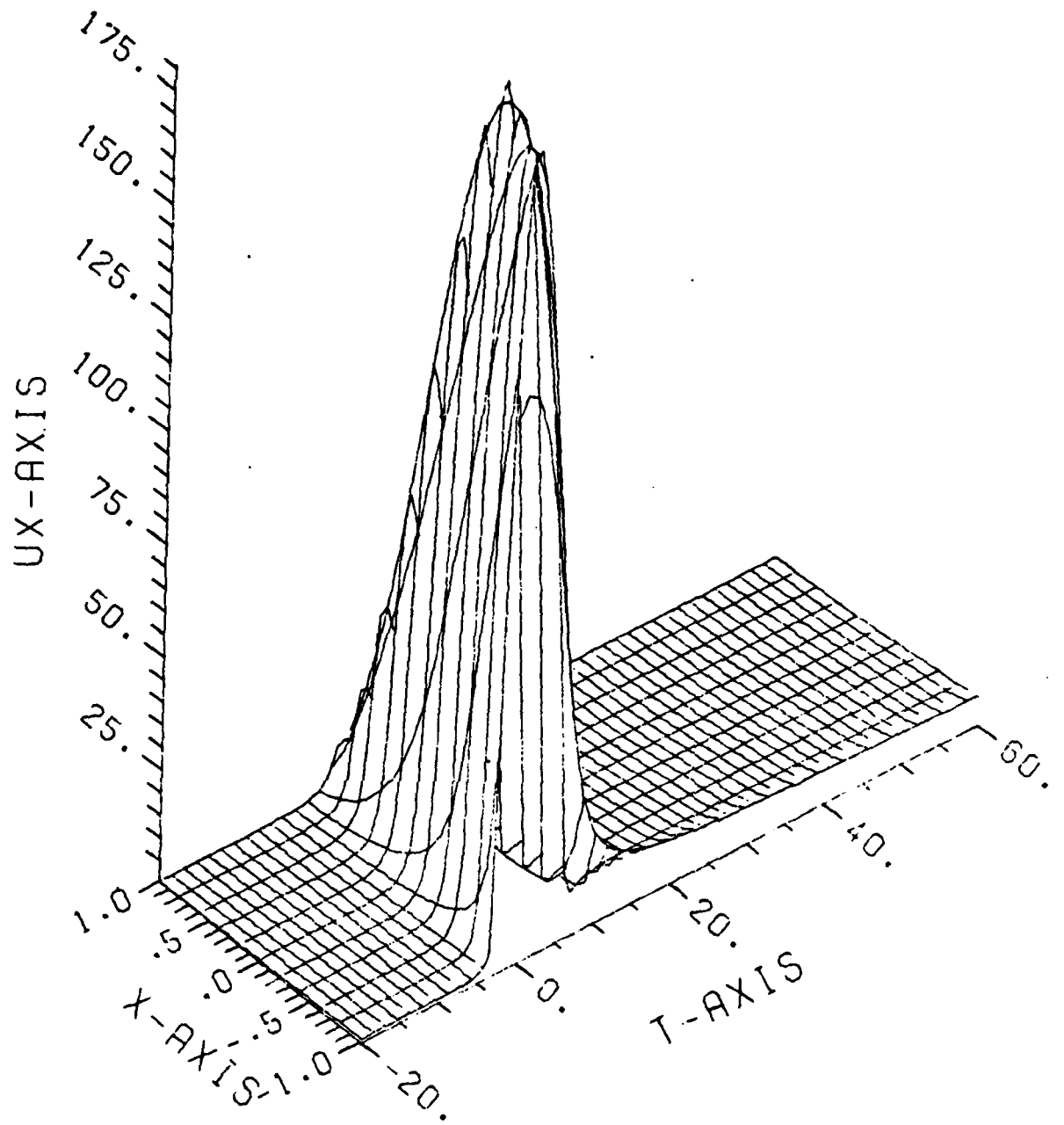

Figure 25



U

Figure 26



UX

Figure 27

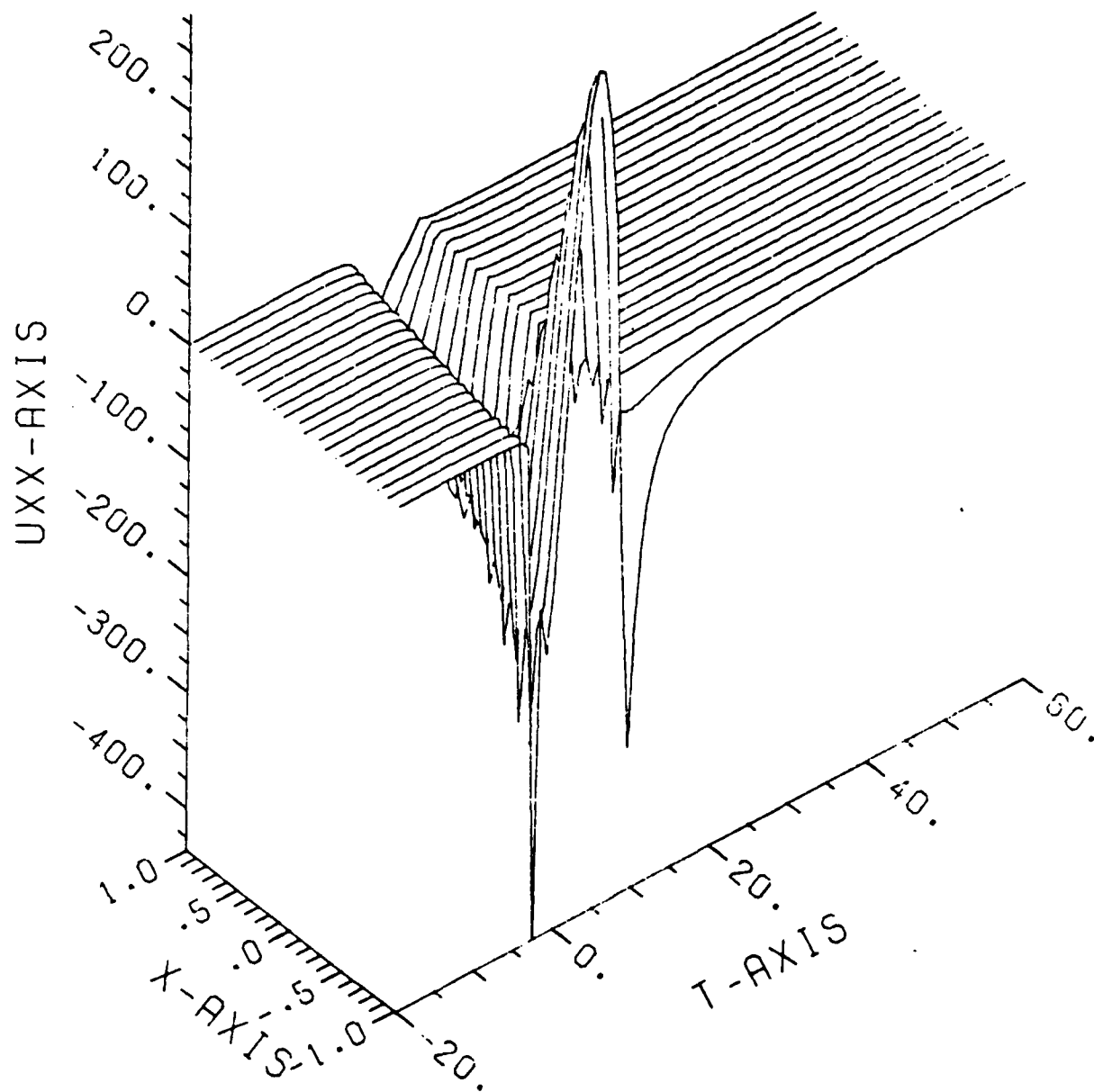

UXX

Figure 28

U-SECTIONS

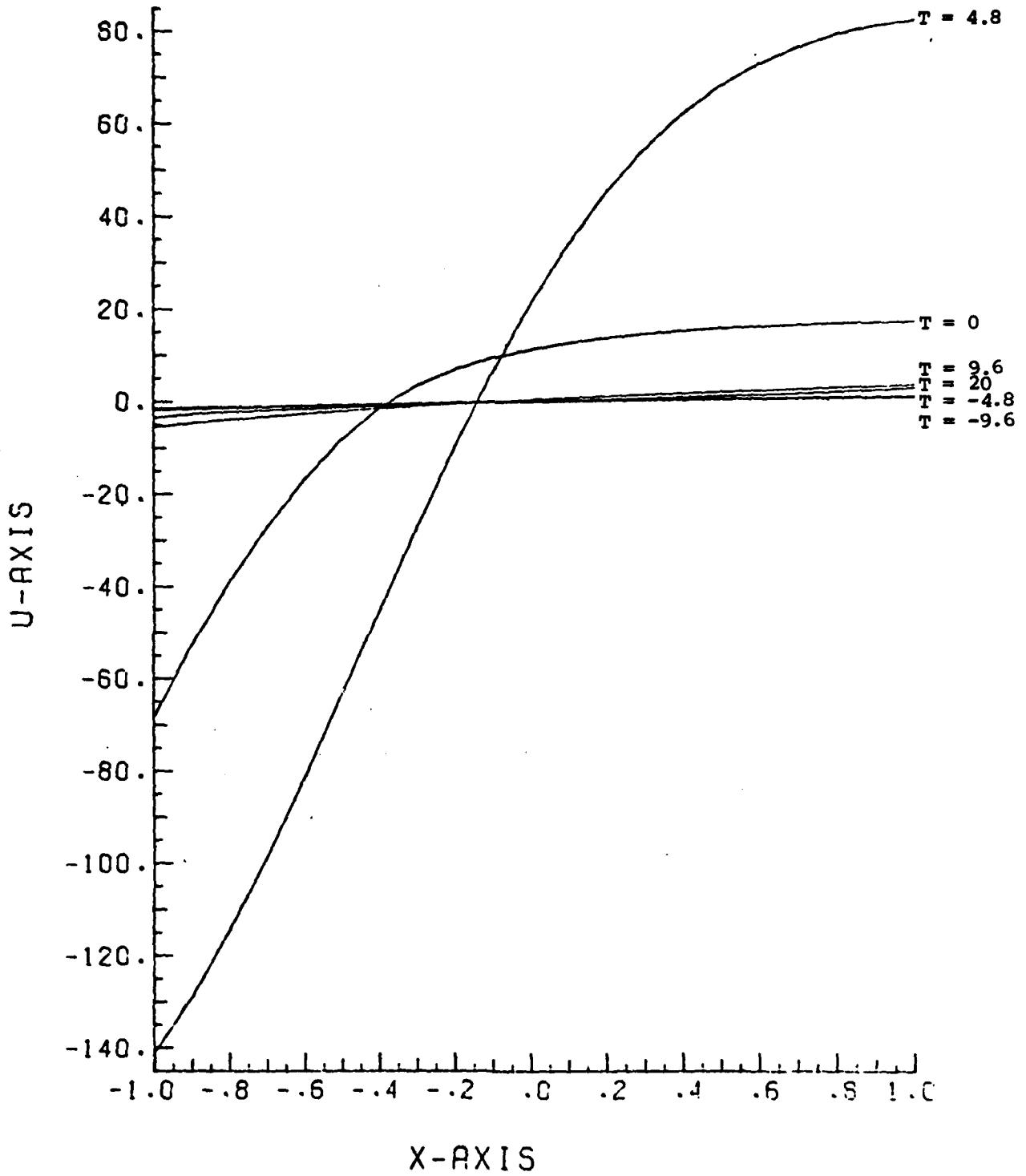

Figure 29

UX-SECTIONS

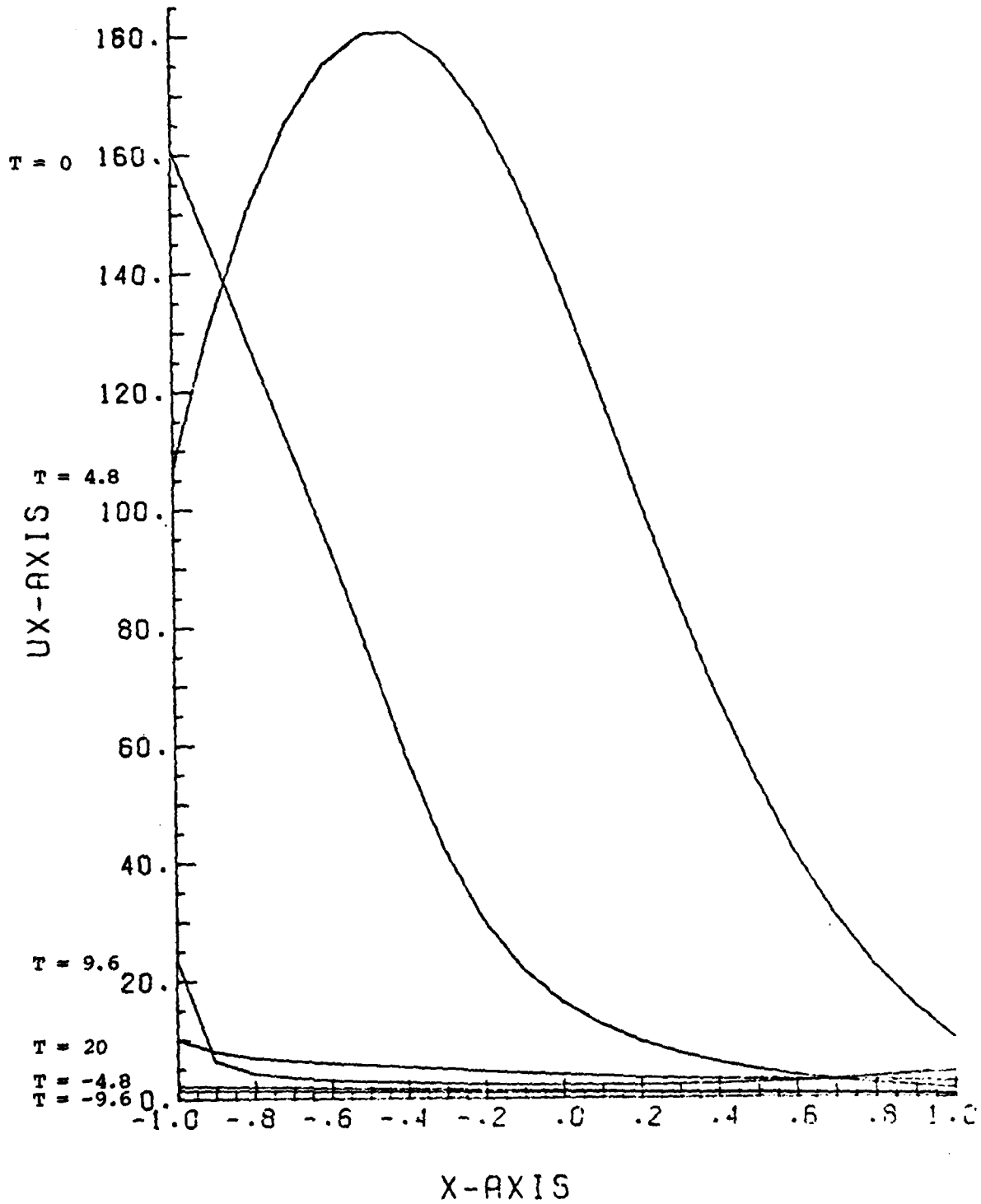

Figure 30

UXX-SECTIONS

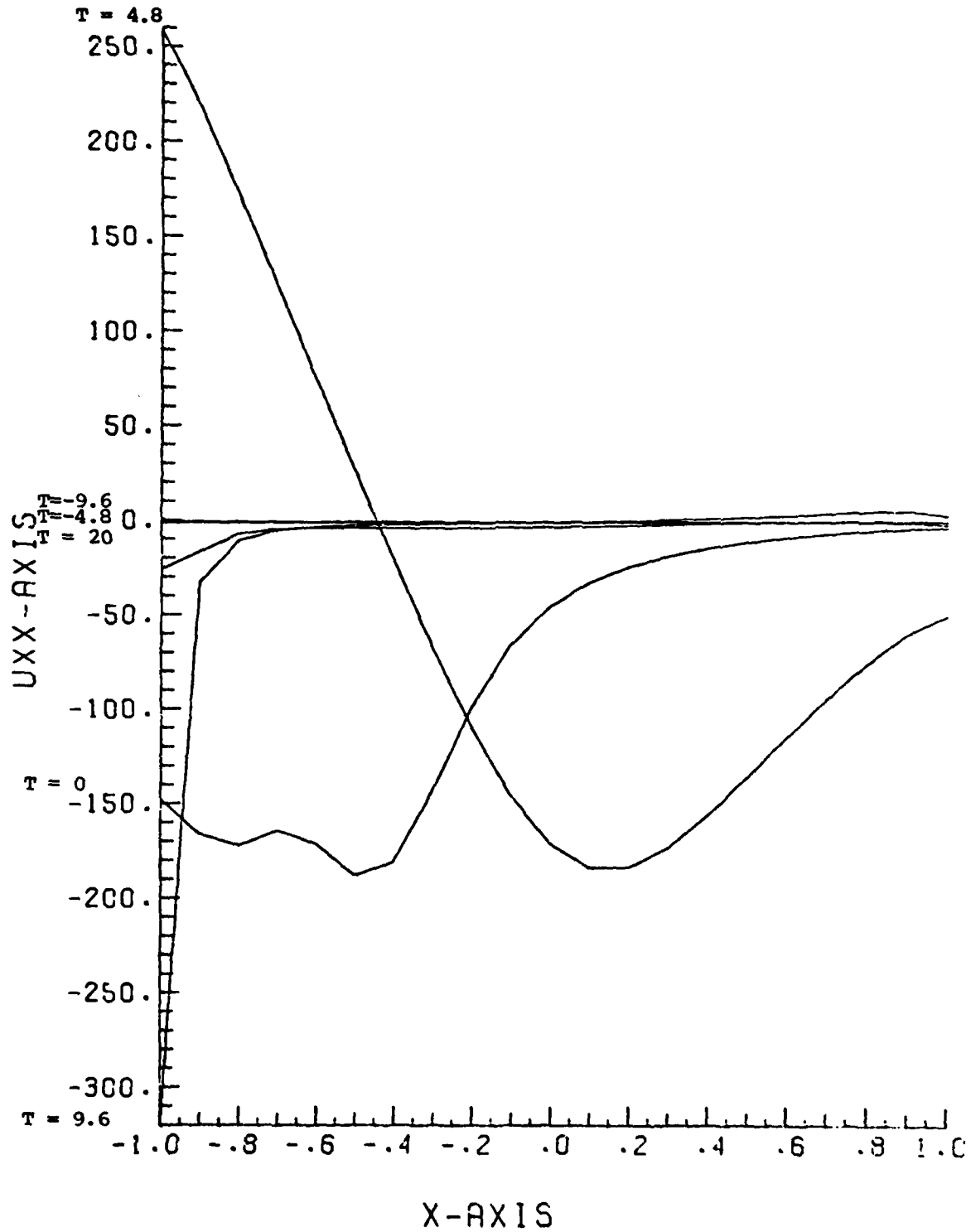

Figure 31

References:

- [1] H. B. Keller, *Approximation Methods for Nonlinear Problems with Application to Two-Point Boundary Value Problems*, Math Comp. 29 (1975), pp. 464-474.
- [2] H. M. Laun, *Description of the Non-linear Shear Behaviour of a Low Density Polyethylene Melt by Means of an Experimentally Determined Strain Dependent Memory Function*, Rheol. Acta 17 (1978) pp. 1-15.
- [3] A. S. Lodge, *Body Tensor Fields in Continuum Mechanics*, Academic Press, New York-San Francisco-London 1974.
- [4] A. S. Lodge, J. B. McLeod and J. A. Nohel, *A Nonlinear Singularly Perturbed Volterra Integrodifferential Equation Occurring in Polymer Rheology*, Proc. Roy. Soc. Edinburgh 80A (1978), pp. 99-137.
- [5] P. A. Markowich and M. Renardy, *A Nonlinear Volterra Integrodifferential Equation Describing the Stretching of Polymeric Liquids*, MRC TSR# 2213, University of Wisconsin, Madison 1981 (submitted to SIAM J. Math. Anal.)
- [6] O. Nevanlinna, *Numerical Solution of a Singularly Perturbed Nonlinear Volterra Equation*, MRC TSR# 1881, University of Wisconsin, Madison, 1978.
- [7] M. Renardy, *A Quasilinear Parabolic Equation Describing the Elongation of Thin Filaments of Polymeric Liquids*, MRC TSR# 2183, University of Wisconsin, Madison 1981 (to appear in SIAM J. Math. Anal.)
- [8] R. D. Richtmeyer and U. W. Morton, *Difference Methods for Initial Value Problems*, Interscience Publishers, Interscience Trans. in Pure and Applied Mathematics, John Wiley and Sons, 1967.

PM, MR:lh

14
MR

REPORT DOCUMENTATION PAGE		READ INSTRUCTIONS BEFORE COMPLETING FORM
1. REPORT NUMBER TSR 2255	2. GOVT ACCESSION NO. AD-A703	3. RECIPIENT'S CATALOG NUMBER 863
4. TITLE (and Subtitle) 6 The Numerical Solution of a Quasilinear Parabolic Equation Arising in Polymer Rheology.		5. TYPE OF REPORT & PERIOD COVERED Summary Report - no specific reporting period
7. AUTHOR(s) 10 P. Markowich and M. Renardy		6. PERFORMING ORG. REPORT NUMBER
9. PERFORMING ORGANIZATION NAME AND ADDRESS Mathematics Research Center, University of Wisconsin 610 Walnut Street Madison, Wisconsin 53706		8. CONTRACT OR GRANT NUMBER(s) 13 DAAG29-80-C-0041 VNSF-MZS 19-27063
11. CONTROLLING OFFICE NAME AND ADDRESS See item 18 below.	10. PROGRAM ELEMENT, PROJECT, TASK AREA & WORK UNIT NUMBERS 3 Numerical Analysis and Computer Science	12. REPORT DATE August 1981
14. MONITORING AGENCY NAME & ADDRESS (if different from Controlling Office) 9 Technical summary rept.,	13. NUMBER OF PAGES 59	15. SECURITY CLASS. (of this report) UNCLASSIFIED
16. DISTRIBUTION STATEMENT (of this Report) Approved for public release; distribution unlimited.		
17. DISTRIBUTION STATEMENT (of the abstract entered in Block 20, if different from Report)		
18. SUPPLEMENTARY NOTES U. S. Army Research Office and National Science Foundation P. O. Box 12211 Washington D. C. 20550 Research Triangle Park North Carolina 27709		
19. KEY WORDS (Continue on reverse side if necessary and identify by block number) Viscoelastic Liquids, Quasilinear Parabolic Systems, Numerical Approximation on Infinite Intervals		
20. ABSTRACT (Continue on reverse side if necessary and identify by block number) This paper is concerned with a numerical study of the equation $\rho \ddot{u} = 3\eta \frac{\partial^2}{\partial x \partial t} \left(-\frac{1}{u_x} \right) + \frac{\partial}{\partial x} \int_{-\infty}^t a(t-s) \left(\frac{u_x(t)}{u_x(s)} - \frac{u_x(s)}{u_x(t)} \right) ds$ where $u(x,t)$ is real valued for $x \in [-1,1]$ and $t \in \mathbb{R}$ with the boundary condition		

20. ABSTRACT, con't.

$$3\eta \frac{\partial}{\partial t} \left(-\frac{1}{u_x} \right) + \int_{-\infty}^t a(t-s) \left(\frac{u_x(t)}{u_x^2(s)} - \frac{u_x(s)}{u_x^2(t)} \right) dt = f(t)$$

at $x = \pm 1$. This problem is a model equation for elongation of a thin filament of a polymeric liquid when the force f is applied at both ends. The initial condition is $u(x, -\infty) = \varphi(x)$. The unknown variable $u(x, t)$ denotes the position of a fluid particle (in a deformed state at time t), which is at position x in space in a certain reference configuration. In this reference state the filament is assumed to be cylindrical. $a(t)$ is a memory kernel, ρ denotes the density of the fluid and η the Newtonian contribution to the viscosity. We set up a difference scheme for this problem and show the convergence under certain assumptions on f and we report computations.