

000-462

LEVEL

D

AD A104059

PRESEARCH
INCORPORATED

DTIC
SELECTED
SEP 10 1981
S D
H

DTIC FILE COPY

DISTRIBUTION STATEMENT A
Approved for public release;
Distribution Unlimited

81 9 03 117

PRESEARCH INCORPORATED

12

DTIC
SELECTED
SEP 10 1990
H

PI TR-27-1

Technical Report No. 298

ANALYSIS AND EVALUATION OF POTENTIAL
COMPETITION OF INTEREST AMONG THE
MAJOR POWERS

Volume I. Summary of Conclusions and
Development of Study Concepts

by

J. S. Breemer and M. E. Miller

30 April 1976

Prepared for
Director, Special Regional Programs
Office of the Assistant Secretary
of Defense
(Program Analysis and Evaluation)
Under
Contract No. MDA 930-75-C-0225

2361 South Jefferson Davis Highway
Arlington, Virginia 22202

DISTRIBUTION STATEMENT A
Approved for public release;
Distribution Unlimited

UNCLASSIFIED

SECURITY CLASSIFICATION OF THIS PAGE (When Data Entered)

| REPORT DOCUMENTATION PAGE | | READ INSTRUCTIONS BEFORE COMPLETING FORM |
|--|--------------------------------------|--|
| 1. REPORT NUMBER | 2. GOVT ACCESSION NO. AD-A104 059 | 3. RECIPIENT'S CATALOG NUMBER |
| 4. TITLE (and Subtitle) Analysis and Evaluation of Potential Competition of Interest Among the Major Powers, Vol. I: Summary of Conclusions and Development of Study Concepts | | 5. TYPE OF REPORT & PERIOD COVERED Final Technical Report |
| 7. AUTHOR(s) J. S. Breemer and M. E. Miller | | 6. PERFORMING ORG. REPORT NUMBER 298 |
| 9. PERFORMING ORGANIZATION NAME AND ADDRESS Presearch Incorporated 2361 So. Jefferson Davis Highway Arlington, Virginia 22202 | | 8. CONTRACT OR GRANT NUMBER(s) MDA 930-75-C-0225 |
| 11. CONTROLLING OFFICE NAME AND ADDRESS Director, Special Regional Studies Assistant Secretary of Defense (Program Analysis and Evaluation), Rm 2D321, The Pentagon, Wash. D.C. | | 10. PROGRAM ELEMENT, PROJECT, TASK AREA & WORK UNIT NUMBERS |
| 14. MONITORING AGENCY NAME & ADDRESS (if different from Controlling Office) Same | | 12. REPORT DATE 30 April 1976 |
| | | 13. NUMBER OF PAGES 153 |
| | | 15. SECURITY CLASS. (of this report) UNCLASSIFIED |
| | | 15a. DECLASSIFICATION/DOWNGRADING SCHEDULE |
| 16. DISTRIBUTION STATEMENT (of this Report) This document has been approved for public release; its distribution is unlimited. | | |
| 17. DISTRIBUTION STATEMENT (of the abstract entered in Block 20, if different from Report) | | |
| 18. SUPPLEMENTARY NOTES This is Volume I of 4 volumes. | | |
| 19. KEY WORDS (Continue on reverse side if necessary and identify by block number) Factor analysis; International competition; Involvement; National interests. | | |
| 20. ABSTRACT (Continue on reverse side if necessary and identify by block number) Volume I summarizes the development of the concepts and technical approach used to operationalize and examine the potential for major power competition using quantitative indices of national interest. Overall study results are detailed. | | |

DD FORM 1 JAN 73 1473

EDITION OF 1 NOV 65 IS OBSOLETE

UNCLASSIFIED

SECURITY CLASSIFICATION OF THIS PAGE (When Data Entered)

EXECUTIVE SUMMARY

PRECIS

1. This report summarizes an analysis of competing international interests between major powers, performed for the Office of the Assistant Secretary of Defense (Program Analysis and Evaluation) under Contract MDA-930-75-C-0225. Activities of six major powers (U.S., West Germany, France, the United Kingdom, U.S.S.R., and Japan) with other nations were correlated by utilizing 20 different indices of involvement. These included imports and exports, direct private investments; tourist flow; military sales and assistance; diplomatic deployments, etc. A data bank and algorithms were prepared and are presently stored in the USAF Multics System.

2. The study has examined interactions between the major powers and over 100 other countries, with detailed inputs, assumptions and results shown in the text and supporting appendices. Study results allow for a number of important interpretive conclusions:

- a. Outside of Eastern Europe, the U.S.S.R. relies primarily on military and economic aid to further its interests, whereas Western presence is dominated by commerce (trade, investment and tourism). Soviet expansionist initiatives are most evident in countries lacking demonstrable Western interests, with external initiatives least likely in areas having a high Western economic profile. Hence strong economic ties may be a more effective means to dilute Soviet influence, than competing military or economic aid programs.

| | |
|--------------------|--------------------------|
| Accession For | <input type="checkbox"/> |
| NTIS | <input type="checkbox"/> |
| DTIC TAB | <input type="checkbox"/> |
| Unannounced | <input type="checkbox"/> |
| Justification | <input type="checkbox"/> |
| By | |
| Distribution | |
| Availability Codes | |
| Dist | |
| Avail and/or | |
| Special | |

A

- b. Western (and particularly U.S.) reaction to successful Soviet overseas aid initiatives has typically been to contract its own level of involvement. Increased Soviet involvement has resulted almost invariably. Maintaining a countervailing Western presence may be a more effective means of inhibiting Soviet expansion.
- c. A high level of commercial involvement may be an attractive, longer-term alternative to outright assistance (in the form of economic or military aid) for enlarging the Western profile in areas having a substantial Soviet presence, such as Eastern Europe, Syria, Egypt, Iraq, India, Afghanistan, Guinea, Algeria, Somali, the Congo and Bangladesh.

3. These interpretive conclusions are based on numerous study findings on Soviet vs. Western styles in influencing third countries. These findings are detailed below in "Summary of Major Findings."

SUMMARY OF MAJOR FINDINGS

GENERAL

1. These paragraphs summarize the final report on the research project entitled Analysis and Evaluation of Potential Competition of Interest Among the Major Powers. The work has been performed for the Office of the Assistant Secretary of Defense (Program Analysis and Evaluation), Director, Special Regional Programs, under Contract No. MDA-930-75-C-0225.

BACKGROUND

2. There is a need for explicit criteria to allocate material and planning resources among numerous competing requirements and potential contingencies. This study was responsive to a requirement by the Assistant Secretary of Defense (Program Analysis and Evaluation) to develop a systematic, empirically-based framework for identifying and examining geographic priorities in U.S. defense planning.

3. Earlier efforts in this direction have been hampered by (a) lack of agreement over the criteria to be used, or (b) insufficient specificity of the criteria. Consequently, although most policymakers can agree that planning ought to be based on the degree of U.S. interest in a particular country, or issue, there has been a consistent failure to translate the idea of interest into a useful operational construct that allows countries or areas to be compared and evaluated against each other on the basis of a set of explicit, recognizable criteria.

4. This study recognizes the crucial role of long-term national aspirations, grand-strategic considerations, moral inclinations, or decision maker idiosyncracies in the determination of a nation's interest in an area. There are at least 2 sound reasons, however, to begin to address the issue of interest in terms of observed patterns for external involvement:

PRESEARCH INCORPORATED

- First, it can be assumed with some confidence that the public and private activities that characterize a nation's involvement abroad, bear witness to its perception of what would constitute the desirable features of the international system
- Secondly, action-policy, i.e., observable external involvement, rather than abstract national goals, guides most policy planning and decisions.

5. Prudent defense planning takes account of the interests and concerns of other nations. Earlier research by the same study team had identified and examined the scope and character of U.S. interests abroad. The present study has expanded upon this work by addressing the external interests of 5 major foreign powers: France, Japan, the Soviet Union, the United Kingdom, and West Germany.

PURPOSE

6. Principal research objectives were:

- To identify and operationalize the economic, political, and military dimensions of the foreign interests of 5 major foreign powers with reference to observed patterns of external involvement
- To examine the interrelationships that characterize the different forms of major power external involvement
- To measure the importance of more than 100 countries in terms of major power involvement
- To assess the potential for major power competition as the result of multiple overlapping involvements
- To develop a comprehensive machine-stored data base that allows the systematic analysis of patterns and trends in major power involvement behavior.

PRESEARCH INCORPORATED

METHODS

7. Each of the 6 major powers studied was addressed in terms of a minimum of 20 measures (variables) of their respective external involvements. Variables were selected in a deliberate effort to, first, encompass an adequate representation of each of the major power's totality of involvement, and secondly, to allow comparison between powers. With some variations, the basic variables included: imports and exports, direct private investments, tourist flows, military sales and assistance, military deployments, diplomatic treaties in force, cultural exchanges, deployments of diplomatic personnel, development assistance, and deployments of civilian advisers. Data are presently stored and updated on the U.S. Air Force Multics system.

8. Once pertinent variables had been identified, the associated values were collected on an annual basis over a 5-year (1968-1972) time frame. Where more recent data were available, they were incorporated into the data base. The purpose of time series data was to examine potentially important trends in the relationship among the variables.

9. Previous research had demonstrated the usefulness of factor analysis as a means to integrate a host of seemingly unrelated variables into a reduced number of clusters of functionally related variables. Specifically, factor analysis draws together those variables that display a high degree of statistical intercorrelation, i.e., variables that tend to coincide systematically across a larger number of cases, may be interpreted as different aspects of the same phenomenon. In addition, a technique called orthogonal rotation was used to test the independence of the different clusters of variables, i.e., the study attempted to discover to what extent different groupings of external activities were, in fact, unrelated to each other. The purpose of this exercise was to clarify the degree to which the expansion or contraction of a particular set of external activities by a major power, say, military involvement, tended to coincide with an increase or decrease of functionally different engagements, e.g., commerce.

10. The next step in the study was to rank the more than 100 countries in the data base on the basis of the defined measures of major power involvement. The purpose was to establish a systematically and openly arrived at baseline for prioritizing the international system from the perspective of the 6 major foreign powers. In addition, the

PRESEARCH INCORPORATED

use of time series data permitted general conclusions and inferences concerning recent trends in the relative distribution of major power involvement. Estimates of the relative importance (in terms of involvement) of different countries to the major powers allowed the problem of international competition among the powers to be addressed systematically.

11. To demonstrate the application of the data base to important defense issues, 4-years of annual data on Soviet naval and merchant marine foreign port call activity were correlated against 8 "traditional" measures of Soviet external involvement in the Third World, e.g., trade, aid, educational exchanges, etc. The objective was to assess how Soviet naval presence related to friends, allies and third countries overseas.

12. The data base is considered rapidly adaptable to enlargement and updating, and provides a firm foundation for further research in other, related areas, including: (a) PRC worldwide involvement (and its interaction with that of the Soviet Union), (b) regional (as compared with global) analyses, (c) the relationship between national capabilities and involvement; (d) "ideal" vs. "real" interests (e.g., explicit consideration of geo-strategic criteria in the assessment of interest); and (e) the linkage between local threat environments and interests.

PRINCIPAL FINDINGS AND CONCLUSIONS

The Soviet Union

13. Six years of empirical data on Soviet political, military, and economic activities in 123 countries from 1968 through 1973 were examined to describe the scope and character of Soviet worldwide external involvement. In addition, Soviet naval and merchant maritime port call activity in the developing nations was studied in an effort to illuminate its relationship to Soviet foreign policy objectives. Main findings and conclusions are summarized next.

14. Unlike the U.S. (or the United Kingdom) Soviet military assistance and sales programs should be viewed as a single arms transfer activity. Countries that purchase Soviet military equipment also tend to benefit from Soviet military grant aid; in general, the larger the purchase of Soviet military hardware, the larger the grant portion of Soviet military aid shipments will be.

15. A moderately strong correlation was found to exist between the flows of Soviet military and non-military (economic) assistance. Countries that benefit from Soviet military assistance also tend to receive economic aid, although the obverse relationship was not found to prevail. Evidently, the recipient of Soviet military aid must meet requirements that are more stringent than those for strictly economic assistance. Alternatively, Soviet economic assistance may be viewed as a "stepping stone" to eventual military aid.

16. A strong positive association was found to have sprung up in recent years between the number of Soviet overseas technicians (obstensibly classified as non-military), and the volume of Soviet arms sales. The relationship may be spurious as it might simply reflect a second-order correlation due to the moderately strong linkage between arms sales and economic aid. On the other, it points to the difficulty in distinguishing with a high degree of confidence between Soviet military and non-military advisory contingents.

17. An increasingly cohesive relationship has developed between the flow of foreign students receiving their training in the U.S.S.R. and the magnitude of Soviet military and nonmilitary aid to the sending countries. Soviet overseas educational programs may be a significant precursor of a more expanded range of Soviet external activities.

18. Soviet trade dominance (in terms of relative import/export market shares) is evident exclusively in Eastern Europe, although to a diminishing degree. The important growth in Soviet trade with the Western nations over the time period studied has been accompanied by a relative reduction in the Soviet share of trade with the Eastern European countries.

19. The worldwide deployment of Soviet diplomatic personnel has become increasingly associated with areas of Soviet trading activity, i.e., the U.S. and Western Europe, while the Soviet diplomatic profile in the Third World aid-receiving countries has undergone a relative decline.

20. The value of Soviet military assistance is strongly related to the size of the recipient country's population, thereby suggesting that the recipient's "size" may be one factor in the Soviet allocation of overseas security resources.

PRESEARCH INCORPORATED

21. Soviet involvement with the developing portion of the world is based almost exclusively on military and economic aid and related programs, which lack the more "organic" substance of mutually beneficial economic ties, shared ethnic or cultural values, or alliances based on a common perception of the threat. Soviet interests in the Third World, in short, lack the "intrinsic solidity" that characterizes Western ties with the former colonies. As a result, it may be speculated that the Soviet presence outside Eastern Europe remains quite vulnerable to sudden upsets in the wake of indigenous or Western initiatives.

22. The full range of Soviet external activities that was examined may be usefully classified according to 6 main types of Soviet external involvement: Military Assistance, Military-Commercial Activity, Commercial Penetration, Political Activity, Political Visibility, and Diplomatic Activity. Table I lists the 10 top-scoring countries on each of the 6 classes of activity based on the global distribution of Soviet overseas resources.

23. Levels of aggregate Soviet external involvement appear to conform to 4 basic patterns:

- A highly stable pattern in countries along the Soviet Union's immediate periphery (e.g., Mongolia, Finland, Afghanistan, Eastern Europe)
- A steadily inclining pattern typified by such countries as Syria, Guinea, West Germany, and the U.S. Soviet success in expanding its presence in the first 2 countries may be partly attributable to the absence of sustained Western attempts to visibly demonstrate its own interest in those countries. Expanding Soviet activity in West Germany and the U.S. may have been by Western initiative, rather than default, i.e., in furtherance of the policies of detente and Ostpolitik
- A prominent pattern of declining Soviet involvement, as exemplified in Cuba, the Sudan, North Yemen, Iran, and Egypt. Different political events and developments may be identified as contributory to

PRESEARCH INCORPORATED

TABLE I
 HIERARCHY OF TOP 10 COUNTRIES ON SIX COMPONENTS
 OF MANIFEST SOVIET INTEREST ABROAD IN 1973

| Military Assistance | Military-Commercial Activity | Commercial Penetration | Political Activity | Political Visibility | Diplomatic Activity | Overall Involvement |
|---------------------|------------------------------|------------------------|--------------------|----------------------|---------------------|---------------------|
| Syria | E. Germany | Mongolia | Guinea | Cyprus | U.S.A. | Syria |
| Egypt | Poland | N. Vietnam | Algeria | Congo | India | E. Germany |
| Iraq | Bulgaria | E. Germany | Syria | Iceland | France | Egypt |
| Afghanistan | Hungary | Czechoslovakia | Egypt | Jordan | Finland | Poland |
| Somalia | Romania | Hungary | Bangladesh | S. Yemen | Switzerland | Mongolia |
| S. Yemen | Czechoslovakia | Bulgaria | India | Finland | U.K. | Bulgaria |
| India | W. Germany | Cuba | Iraq | Mauritania | Austria | Iraq |
| Iran | Finland | Poland | Turkey | Lebanon | Poland | India |
| Mali | Yugoslavia | Egypt | Afghanistan | C.A.R.* | W. Germany | Hungary |
| Cuba | Mongolia | N. Korea | Somalia | Syria | Romania | Romania |

* Central African Republic

the proportionate reduction in Soviet activity in these countries; however, one common denominator appears to have been a renewed U.S./Western willingness to seek improved, or to expand relations

- A cyclical pattern of activity as demonstrated by greatly fluctuating levels of Soviet involvement with Algeria, the Congo, Turkey, and Iraq. The apparent lack of success thus far by the Soviet Union to maintain a sustained level of involvement in these countries may be explained, in part, by the extensive Western economic and political ties that continue to exist, i.e., Algerian and Iraqi dependence on Western trade and technology; extensive Congolese financial and economic ties with its former colonial mother country, France, and important economic and security-related links between the U.S. and Turkey. A cyclical pattern of Soviet external involvement in certain countries may be evidence of the previously discussed difficulty of Soviet aid policy in displacing the more substantive Western economic and political ties.

24. On a worldwide basis, no appreciable relationship exists between the geographic patterns and frequencies of Soviet naval and merchant marine port calls. The evidence appears to confirm that Soviet naval forces are not deployed systematically to protect Soviet maritime traffic. Also, on a worldwide basis, no systematic relationship to speak of could be established between the pattern of Soviet naval visits, and the flow of Soviet economic and military assistance. The data does not sustain evidence of a worldwide Soviet naval presence role in support of friends and client states.

25. On a worldwide basis, a strong positive relationship exists between the volume of Soviet merchant marine port calls, and the flow of Soviet economic and military assistance. The evidence confirms the important role of the Soviet merchant marine in Soviet arms and economic aid policy. The pattern of Soviet port call activity along the Indian Ocean failed to show a significant relationship between naval port calls and the flow of Soviet military

aid and advisory personnel. Soviet-aligned nations are as likely to be visited by Soviet naval units as are neutrals, or Western allies. The evidence fails to support the thesis that Soviet naval activity in the Indian Ocean is designed to demonstrate the Soviet commitment to its allies.

26. Along the West African coast, a strong positive relationship exists between the geographic pattern of Soviet naval port visits, and the flow of military aid. The evidence supports the contention that Soviet naval forces in the area are utilized in a deliberate presence role in support of aligned states. In the Mediterranean Basin-Persian Gulf region, the frequency and geography of Soviet naval visits are closely associated with the geographic pattern of Soviet merchant marine port calls. This finding provides some preliminary evidence of a systematic attempt by the Soviet Union to establish local sea control in protection of Soviet merchant marine traffic.

27. In the same area, the distribution of Soviet naval port call activity is strongly related to the flow of Soviet military assistance. As was the case along the West African coast, the evidence confirms the role of the Soviet navy as an instrument of peacetime presence on behalf of Soviet-aligned nations. Soviet naval deployments, purposes, and intentions should probably be examined in regional frameworks, rather than from a global perspective.

The United Kingdom

28. One hundred and thirteen countries were examined across 26 discrete measures of British governmental and private involvement during the timespan 1970-1972. Principal findings and conclusions are summarized below.

29. Overseas deployments of British military forces are closely associated with areas of British arms sales, thereby confirming the important role that the United Kingdom military continues to play in the training of foreign military forces. Like the U.S., British external involvement displays a distinct commercial dimension composed of trade and overseas investment activities, formal treaty arrangements, tourist flows, and - in contrast with the U.S. (and the Soviet Union) - diplomatic activity.

30. Unlike the U.S. and the Soviet Union, the geographic deployment of British foreign service personnel is strongly related to areas of main British commercial interest, i.e., trade and investment. A relevant proposition is that, whereas U.S. and Soviet diplomatic staffs tend to be concerned primarily with international security affairs, British diplomatic personnel concentrate mainly on matters of economic importance. U.S. defense planners must be sensitive to this difference in values, and the different perceptions of events that may result.

31. The United Kingdom's formal (military and non-military) treaty relationships are concentrated primarily in areas of significant economic interest. The profile of U.S. involvement, by contrast, showed that U.S. treaties have tended to be concluded with significantly less attention being paid to the economic importance of the other signatory(ies). Again, the close interaction between economics and diplomacy that dominates British foreign policy appears to be confirmed.

32. A dominant British trade position is evident primarily in countries that rely heavily on British economic assistance, and technical advice, i.e., Subsaharan Africa. From 1970 to 1972, British commercial-diplomatic involvement with Western Europe showed an appreciable increase, paralleled with a commensurate decline in relative involvement with the U.S. This occurrence, in combination with the relative decrease in U.S. involvement in the United Kingdom that was uncovered in the earlier U.S. study, may be evidence that the "special relationship" between the 2 nations is on the decline.

33. The United Kingdom's primary commercial-diplomatic interests are located around the North Atlantic Ocean, i.e., the U.S., Canada, Ireland, and the Western European nations. Outside Europe and North America, principal British commercial-diplomatic assets are found in Australia, India, Japan, New Zealand, and South Africa. Outside its primary commercial-diplomatic involvement with the industrial world, Britain's overseas activities are concentrated almost exclusively in the Commonwealth nations. The level of British involvement in Central and South America is insignificant compared with the remainder of the international system.

34. Despite military withdrawal east of Suez, the United Kingdom retains a high degree of political and commercial visibility in Kuwait, the United Arab Emirates, Iran,

Malaysia, and Singapore. This implies that the United Kingdom remains highly sensitive to U.S. or Soviet initiatives in the Indian ocean basin in general, signifying, in turn, the importance of Western policy coordination in the area. The United Kingdom's commercial dominance in the smaller Subsaharan nations, and the area's dependence on British development aid and expertise suggest the existence of a significant degree of British policy leverage.

35. Commercial interests appear to be the prime motivating factor in British foreign policy behavior.

Japan

36. Four years of data on 23 distinct aspects of Japan's patten of foreign involvement were available for study with the following results.

37. Japan's formal diplomatic activity is closely linked with areas of important commercial interest, thereby questioning the reality of Japan's ostensible policy of separating trade from politics. Japanese development assistance is concentrated principally in countries that (a) are highly dependent on Japanese trade, or (b) are rich in mineral resources, or are producers of primary commodities: Indonesia, South Korea, Phillippines, Thailand, Brazil, India, and Iran.

38. Primary areas of Japanese commercial interests lie outside East and Southeast Asia, i.e., in the U.S., Western Europe, and Australia. Japanese external involvement is a worldwide phenomenon - in terms of commerce and aid-giving, Japan is a power of worldwide proportions. Countries that have witnessed the most rapid increases in Japanese involvement across all facets of activity are: Singapore, Indonesia, Brazil, South Korea, and Switzerland.

General Conclusions

39. From the preceding individual country studies a number of general observations concerning the overall characteristics of major power external involvement are derived. For example, the scope and distribution of a major power's external involvement does not appear to be visibly constrained by considerations of geographic distance.

PRESEARCH INCORPORATED

40. The strong interrelationships that exist among different types of activities, indicate that the full range of a major power's involvement may be usefully examined with reference to a limited number of "key" activities, or variables. For example, the flow of exports is a key indicator of a broad range of engagements, that together, combine to form the commercial dimension of a nation's involvement.

41. Traditional (i.e., pre-World War II) areas of major power economic or colonial dominance have remained relatively intact. Thus Japanese trade dominates East and Southeast Asia; British commerce extends through Subsaharan Africa; U.S. trade dominates the economies of Latin America; Soviet trade (and increasingly West German commerce) prevails in Eastern Europe, while West German market penetration is most visible in Western Europe.

42. High levels of major power involvement tend to be "preclusive," i.e., instances are rare where high levels of major power activity coincide in the same country. This is particularly so in countries on the immediate periphery of a major power. Evidently, a visibly high level of interest by one power tends to deter efforts by a second power to offset or replace the original power. This finding suggests that adversary initiatives are most likely to occur in countries that lack a demonstrable major power interest. Intersecting or overlapping major power involvements tend to occur on a regional rather than local level.

43. Except for military presence, the totality and variety of Western worldwide involvement is far greater than that of the Soviet Union. Western involvement is based on intrinsically enduring ties such as trade, shared ethnic and cultural values, and high levels of interpersonal interchange. Soviet involvement, by contrast, is dominated by economic and military aid programs.

TABLE OF CONTENTS

| | <u>Page</u> |
|--|-------------|
| EXECUTIVE SUMMARY | i |
| SUMMARY OF MAJOR FINDINGS | iii |
| I. INTRODUCTION | 1 |
| General; Background; Purpose; Contents. | |
| II. STUDY OVERVIEW AND PRINCIPAL CONCLUSIONS . . . | 3 |
| General; Background; Purpose; Conceptual Approach; Methodological Approach; Study Progress; Application of the Data Base; Major Findings; Identifying Areas of Competition of Interest; Findings on Soviet Maritime Behavior. | |
| III. CONCEPT OF NATIONAL INTEREST | 26 |
| General; National Interest as a Policy Construct; Recent Attempts at Classifying National Interests; National Interest as an Operational Problem; Routine Character of Most Foreign Policy; Political Relevance of Interest in Action; Applications. | |
| IV. CONCEPT OF INTERNATIONAL COMPETITION | 47 |
| General; International Relations as Competitive Behavior; Rousseau's Theory of International Conflicts; Decision-Maker's Perception of International Politics as Competitive Behavior; Why Great Powers Get Involved: | |

PRESEARCH INCORPORATED

Policy Relevance of Examining Multiple Power Involvement; International System Changes and the Potential for Competition; Relationship Among Different Types of Foreign Involvement; International Multipolarity and Intensified Competition; Risks of Involvement; Summary.

V. OPERATIONALIZATION OF CONCEPTS 76

General; External Involvement as a Measure of Interest; Variable Selection; Classification of Manifest Interests; Economic Interests; Direct Private Investment; International Movement of Nationals; Operationalization of Economic Interests; Political Interests; Treaties in Force; Diplomatic Presence; Development Assistance; Cultural and Educational Exchanges; Operationalization of Political Interests; Military Interests; Military Deployments; Military Treaties; Security Assistance; Arms Sales.

VI. METHODOLOGY 110

General; Correlation Analysis; Factor Analysis; Factor and Composite Scoring.

APPENDIX: SOURCE DATA DOCUMENTATION 122

LIST OF ILLUSTRATIONS

| | <u>Page</u> |
|---|-------------|
| <u>Figure</u> | |
| 6.1. Representation of Orthogonal Simple Structure Rotation of Eight Hypothetical Variables | 114 |
| <u>Tables</u> | |
| 2.1. 25 Top-Scoring Countries for 5 Major Powers in 1972 | 16 |
| 2.2. Regional Distribution of 5 Major Powers' 25 Principal Local Areas of External Interest in 1972 | 18 |
| 2.3. Interaction of Major Power Manifest Interests in Selected Countries in 1972 | 20 |
| 6.1. Final Rotated Factor Matrix of Manifest Soviet Interest Data in 1973 | 116 |

I. INTRODUCTION

GENERAL

1.1 This volume contains the summary of the results and technical approach to the four-volume final report on a study entitled Analysis and Evaluation of Potential Competition of Interest Among the Major Powers. The work was performed for the Office of the Assistant Secretary of Defense (Program Analysis and Evaluation), Director, Special Regional Programs, under Contract No. MDA 930-75-C-0225.

1.2 The study was performed in accordance with a requirement by the Office of the Assistant Secretary of Defense to develop a comprehensive empirical data base that will permit a systematic analysis of the scope and character of the foreign involvements and activities of five major international actors: France, Great Britain, Japan, the Soviet Union, and West Germany. The data base was designed to complement a similar file that had been established to account for U.S. external activities.

BACKGROUND

1.3 In recent years there has been a growing concern that the rational allocation of defense planning resources requires an explicit estimate of the demonstrable foreign interests and commitments of U.S. allies as well as adversaries. The

PRESEARCH INCORPORATED

study was undertaken to consider this problem and to try to provide the defense planner with an accessible, centralized comprehensive data base that permits quick and reliable access to the aggregate statistical information that is needed to examine important defense questions.

PURPOSE

1.4 The purpose of Volume I is to provide an overview of the study's principal research objectives, conceptual and methodological development, and main findings. The volume also considers the applicability of the data base to the study of important defense issues.

CONTENTS

1.5 Section II presents a general overview and the principal conclusions of the study. The conceptual and methodological approach of the study is described in Sections III, IV, and V. Section VI explains the procedures that were used to operationalize the concepts outlined in Section III. Finally, the Appendix provides an exhaustive data documentation.

II. STUDY OVERVIEW AND PRINCIPAL CONCLUSIONS

GENERAL

2.1 This section summarizes the study's basic rationale, objectives, conceptual milestones, and principal findings. The summary of findings includes a demonstration of the potential use of the data to better understand the phenomenon of international competition of interests.

BACKGROUND

2.2 The study was initiated in response to a requirement by the Office of the Assistant Secretary of Defense (Program Analysis and Evaluation). The study was undertaken to develop a systematic means for examining the foreign interests and involvement by five of the principal foreign international actors throughout the international system: France, Great Britain, Japan, the Soviet Union, and West Germany.

2.3 A principal study criterion was to base the implementation and conclusions on empirical data to the greatest possible extent. A foreign nation's interests abroad were examined by means of the observable and, hopefully, measurable patterns of involvement. This reliance on the observable patterns generated a very large data requirement, which, because of its size, had to be managed and manipulated on a computer.

PRESEARCH INCORPORATED

2.4 A significant amount of relevant experience had been gained by the study team as the result of an earlier study entitled Identification and Measurement of U.S. Interests Abroad. ^{1/} This study demonstrated the usefulness of aggregate data research techniques to arrive at a systematic and comprehensive description of the U.S. interest in local areas as it is manifested in the scope and character of private and public overseas involvements. The results of this study were sufficiently promising to apply similar research methods to an expanded number of major foreign international actors. This task was undertaken in the knowledge that the collection of reliable foreign data would be significantly more complex than the original U.S. study. The study team was reasonably confident that the data requirement could be met.

PURPOSE

2.5 The study had four major purposes. The first objective was to examine the functional interrelationships that exist among the multiple manifestations of each of the five major powers' foreign involvements. This examination would hopefully result in a more comprehensive, clearer description of the totality of each major power's external interests than could be attained by considering each of its discrete manifestations separately.

2.6 The second study objective was to evaluate, or measure, over 100 countries on the basis of the external interest model

^{1/} Westinghouse Electric Corp., Center for Advanced Studies and Analyses, Identification and Measurement of U.S. Interests Abroad, Falls Church, Va., Contract No. MDA-903-74-C-0223, November 1974.

PRESEARCH INCORPORATED

that was found to describe the multifaceted network of involvements of each of the five major foreign powers' studies. It was hoped that a set of explicitly arrived at and mutually consistent criteria could be established as a baseline for identifying the relative priority of countries to each of the five major foreign powers. In addition, time-series data were used to examine possible trends in relative geographic priorities.

2.7 The third study objective was to investigate the potential applicability of the data to a systematic demarcation of actual or potential geographic areas of major power competition. If international rivalry is implicit in the intersection of multiple powers' interests, then varying degrees of competition might be highlighted by comparing the relative priority of different countries to each of the major international actors.

2.8 The fourth and perhaps most important purpose of the study was to demonstrate the applicability of aggregate data and statistical research techniques to defense planning issues. A comprehensive data base would be created that would allow the policy planner to test various defense-related hypotheses (or to generate new ones), to examine planning assumptions, or perhaps simply to illuminate particular issues and problems.

CONCEPTUAL APPROACH

2.9 The study was based on the proposition that the scope and character of a nation's observable foreign involvements represent a reliable, although limited, measure of its external interests. In addition, since the bulk of such activities

PRESEARCH INCORPORATED

are observable (and are duly recorded by various private and public bureaucracies), a nation's interests (defined in terms of manifest involvement) in foreign countries should be measurable. For example, if the provision of economic assistance is one valid manifestation of the importance of a recipient nation to the donor country, then the relative importance of the aid-receiving country may be measured in terms of the dollar (or ruble, or pound sterling) amount of aid it receives in proportion to other aid-receiving nations.

2.10 By relying exclusively on the measurable components of a nation's interest abroad, the study avoided the consideration of more intangible (although, at times, decisive) aspects of national interest. Such abstract considerations include ideology and morality, decision-maker perceptions and biases, and strategic values. The study was concerned with the actuality, not the ideality, of a nation's foreign interests. The purpose of the study was to make explicit those local areas where a reassessment of the U.S. interest may be desirable.

2.11 A major international actor's interests abroad may be labeled as predominantly political, military, economic, or as some combination of the three. An effort was made to identify and collect empirical data that are generally recognized as characteristic of these three types of interest. The principal indicators of a political interest that were selected included formal treaty relationships, diplomatic representation, cultural and educational exchange programs, and economic assistance. Main military indicators included military assistance and arms sales, overseas troop deployments, and military treaty arrangements. Finally, trade

PRESEARCH INCORPORATED

flows, overseas investments, and tourist flows were selected as representative of a major actor's economic or commercial stake in a foreign nation.

2.12 Altogether 14 primary indicators were found to be consistently available for all five major actors studied. They were:

- Bilateral dollar flows of exports
- Bilateral dollar flows of imports
- Monetary value of direct private investments
- Number of tourists abroad
- Number of general bilateral and multi-lateral treaties in force
- Personnel strength of diplomatic representations
- Number of participants in cultural and educational exchanges
- Dollar value of development assistance
- Number of development advisers abroad
- Number of development volunteers abroad
- Dollar value of security assistance
- Dollar value of arms sales
- Number of military personnel abroad
- Number of military bilateral and multi-lateral treaties in force.

PRESEARCH INCORPORATED

2.13 A number of additional primary indicators were only available for selected countries. For example, it was found that, aside from the U.S., only Japan makes available annual statistics on the number of its nationals that reside abroad. Also, the planned use of long-term immigration data to examine the impact of cultural and ethnic ties had to be rejected due to the lack of relevant information for France, Great Britain, and the Soviet Union.

2.14 It must be stressed that the distinctions among political, military, and economic interests were used only as a guide in the collection of indicators and not as a priori classifications of a major actor's interest in a foreign country. One of the objectives of the study was to uncover the de facto character, or dimensional profile of a major actor's manifest interest abroad through the empirical interrelationships that exist among its various manifestations. In the original U.S. study it was discovered that, contrary to expectations, military and political indicators of the U.S. interests tended to co-occur. This suggested the existence of a combined military-political interest phenomenon, rather than two discrete military and political categories of interest.

2.15 An initial objective of the research was to acquire relevant data for the period 1968 through 1972. During the study, it was decided to make a maximum effort to update the foreign data collections to 1973 and, if possible, 1974. It was also decided to extend the existing U.S. data file by including the years 1973 and 1974. The study team was able to meet these goals for the U.S. and the Soviet Union. Data as recent as 1974 is currently available for examination.

PRESEARCH INCORPORATED

2.16 In the case of the four remaining foreign international actors (France, Great Britain, Japan, and West Germany) only partial 1973 and 1974 data could be acquired.

2.17 In addition to the collection of primary variables, a series of derived indicators was compiled to account for the impact that a country's size might have on the absolute value of a major actor's investment. It is unclear, for example, whether a country's importance as an aid recipient should be measured in terms of the absolute dollar value it receives, or if the value of the aid per capita of the population is the more appropriate criterion.

2.18 The use of a "criterion of proportion" (e.g., aid disbursements per capita) has an additional advantage. It provides the analyst with a rough measure of the proportional visibility of a U.S. or Soviet aid program in a particular foreign region or country. It is all too easy to overlook the disproportional impact of relatively minor programs on small countries. For example, the presence of 3,000 U.S. military forces in Iceland signifies that 1 out of every 65 residents is a U.S. soldier. If this same proportion was applied to West Germany, there would be 1,500,000 soldiers in Germany, instead of the 250,000 now there.

2.19 Population was used as the primary control for the effect of a country's size. An additional size indicator in the analysis was the proportional share of trade dominated by the individual five international actors in their respective bilateral commercial relationships.

METHODOLOGICAL APPROACH

2.20 R-factor analysis with simple structure orthogonal rotation was employed to condense the multitude of individual variables and their associated values for each of the more than 100 countries examined into a meaningful number of summary dimensions of interest. Each of the five national data collections was factor-analyzed on an annual basis to determine the manifest interest profile peculiar to each of the five foreign actors, to examine the stability or uniformity of each of the national profiles across time, and to create an economical means for measuring the relative "value" of the countries to each of the five principal international actors.

2.21 The use of factor analysis was chosen for its proven ability (as demonstrated in the original U.S. study) to reduce apparently unrelated information to a limited number of analytically manageable common factor patterns or variable dimensions. The technique was applied in this study to investigate to what extent the manifestations (both primary and derived) of the British, French, Japanese, West German, and Soviet interests abroad could be reduced into distinct dimensions of functionally interrelated indicators of interest. Statistically, factor analysis groups together those variables that display a high degree of intercorrelation. This permits the researcher to infer the existence of a set of common causes or influences. The variable groupings become new, composite variables.

2.22 After extensive experimentation, it was found that a constrained six-factor profile produced the optimum combination of data comprehensiveness and conciseness. A more extended

factor solution (for example, 10 factors) might capture a larger proportion of the information (variation) contained in the original source data but would dilute the objective of descriptive simplicity. Conversely, the elimination of additional factors might present more concise data, but it would result in a significant loss in the explanatory power of the original source data. It was discovered that approximately 75% of the total variance contained in the original data was retained in the six-factor solutions.

2.23 Factor-scoring was employed to measure and rank-order over 100 countries on each of the five major actor's six-factor interest models. For example, instead of testing the importance of a country to Japan in terms of (a) its receipt of Japanese development loans and grants, (b) the number of Japanese technical advisory personnel on its soil, and (c) the number of Japanese overseas development volunteers it hosts, a single Aid and Trade Penetration factor, or dimension, was used. As another example, Great Britain's manifest commercial stake in a country was measured on the basis of a single multivariate Commercial-Diplomatic dimension, which included such variables as imports, exports, direct private investments, tourist flows, diplomatic staffs, and treaties in force.

2.24 In addition to the individual dimensional scores, a series of cross-dimensional composite scores was created for each of the more than 100 countries in the data collection. This procedure (which will be discussed more fully later) was replicated for each of the five major international actors' studies and represents a comprehensive summation of the totality of the five actors' manifest interests in each of the target nations. It must be emphasized that the dimensional and the composite scores are unique to the individual

YONNG

PROJECT: AQ 2667-CTD

NO. CYS RECD: 2 ^{VOLS} I, II, III, IV

DATE RECD: 7-8-76

ROUTING: 1. MIS/KOEIHER

2. _____

3. _____

major actors; the values associated with the over 100 countries represent those countries' relative standings within the worldwide distribution of external interests that are peculiar to each of the five major actors. Statistically, a nation's dimensional score can be treated as the standard score of a case in a distribution. As a standard score is used to determine the position of a single case in a distribution to make it possible to compare the positions of cases in different distributions, so the dimensional/composite scores may be used to compare the relative importance of a country from one major actor to the next. For example, India's composite score of 0.40 on the Japanese interest distribution, compared with its score of 1.21 on the Soviet hierarchy of interests, indicates that India is substantially more important from the Soviet perspective than it is from the Japanese. The two scores, however, cannot be used to compare absolute levels of interest. Conceivably, the absolute value of Japan's involvement in India might be substantially higher than the Soviet Union's; however, in proportion to both nations' worldwide levels of involvement, the Soviet Union has allocated more resources to India than Japan has.

STUDY PROGRESS

2.25 As the study progressed, extensive exploitation of the Soviet data base became the first research priority. In addition, the existing U.S. data collection was expanded to include the years 1973 and 1974. These two requirements necessarily compromised progress on the remaining four national data collections, particularly France and West Germany. As a result, these two nations have been subjected to only a preliminary analysis and will not be reported on extensively in this report.

APPLICATION OF THE DATA BASE

2.26 To demonstrate the usefulness of the data base in examining important defense questions, 4 years (1970-1973) of Soviet external involvement data were related to the annual frequency of Soviet naval and merchant maritime foreign port visits. The objective of the exercise was to test the empirical evidence of the Soviet Union's use of naval strength in an external "presence" role. In addition, the data were used to examine the relationship between Soviet naval and merchant marine traffic.

MAJOR FINDINGS

2.27 The study has demonstrated the usefulness of aggregate data research techniques to sharpen the policy analyst's insight into the complex character of a major power's interactions in the international system. Relationships, whose existence had only been surmised or had not been considered at all, have been confirmed (or rejected) on the basis of explicit information. Some of the prominent findings include the discrete identities of Soviet military and economic assistance programs. It was found that, when related to other forms of Soviet external involvement, these two activities do not exhibit the kind of cohesiveness that they are generally thought to have. Instead, Soviet involvement abroad tends to be characterized by two independent dimensions of economic and security assistance.

2.28 In the case of Japan, it was found that the ostensible separation of trade from politics has little basis in fact. Japan's strongest diplomatic interests are concentrated in areas where Tokyo maintains its most important economic stakes.

PRESEARCH INCORPORATED

2.29 The Japanese and British external interest profiles were found to differ significantly from that of the U.S. International security concerns tend to dominate U.S. diplomatic activities, while commercial interests are generally the focus of Japan's and Great Britain's foreign policies.

2.30 Country-scoring revealed where the major powers have concentrated their principal interests and where those interests intersect. The study also determined where the potential for competition appears most likely; actual or potential major power rivalry tends to be regional, rather than local. The empirical basis for this conclusion follows.

IDENTIFYING AREAS OF COMPETITION OF INTERESTS

2.31 An important objective of the study was to assess the usefulness of the data and analytic procedures as potential means for identifying local areas of actual or potential competition of interest among both allies and adversaries. It was hoped that the use of composite-scoring to rank-order the local manifest interests of the individual major powers might serve as comprehensive indices of intersecting interests, which, in turn, could indicate areas of gradating international rivalry.

2.32 The following paragraphs outline the premises and procedures that were followed in the preliminary examination of the usefulness of the data in defining local areas of competition among the major powers. To keep the examination manageable, it focused on the top-ranking 25 countries for each of the 5 major powers.

Premises

2.33 Two major conceptual premises were used to circumscribe local areas of major power competition. The first is that international competition is characteristic of most international interaction and that competition is implicit in the intersection of multiple power involvements. The second premise is that one measure of the degree of actual or potential competition of interests may be derived by comparing the relative priority of a local area (or country) to two or more major powers. The latter approach does not focus on a comparison of absolute levels of interest. Instead, it measures the difference between the proportionate amounts of interest that two or more major powers have chosen to invest in one country relative to their worldwide interests. This approach is based on the proposition that the importance of Country X to Japan, for example, should be measured in relation to Japan's interests elsewhere, rather than in comparison to the U.S. interest in Country X.

2.34 Table 2.1 lists the top-scoring 25 nations for each of the 5 major international actors in 1972. The actual scores are shown and are indications of the countries' cardinal positions relative to each other as well as in reference to the five major powers. The scores represent an aggregate, weighted index of a major actor's foreign interests as measured across all the forms of external involvement that have been examined in the study. The fact that a small African nation may rank higher than a large industrialized power is probably due to its position as an important aid recipient, or because its trade is virtually dominated by a single major power.

TABLE 2.1
25 TOP-SCORING COUNTRIES FOR 5 MAJOR POWERS IN 1972

| Great Britain | | Japan | | Soviet Union | | U.S. | | W. Germany | |
|---------------|-------|---------------|-------|----------------|-------|---------------|-------|---------------|-------|
| Country | Score | Country | Score | Country | Score | Country | Score | Country | Score |
| W. Germany | 1.38 | U.S. | 2.78 | Syria | 2.07 | Canada | 3.09 | Turkey | 1.31 |
| Singapore | 1.01 | Singapore | 1.80 | E. Germany | 1.70 | W. Germany | 1.55 | Italy | 0.92 |
| U.S. | 0.89 | Brazil | 1.37 | Mongolia | 1.69 | S. Vietnam | 1.47 | Denmark | 0.89 |
| Zambia | 0.71 | Philippines | 1.13 | Egypt | 1.56 | Iceland | 0.93 | France | 0.89 |
| Swaziland | 0.65 | Indonesia | 1.06 | Poland | 0.99 | Japan | 0.73 | Netherlands | 0.88 |
| Cyprus | 0.61 | Switzerland | 1.03 | Iran | 0.89 | Israel | 0.69 | U.S. | 0.70 |
| Malta | 0.60 | S. Korea | 1.01 | Bulgaria | 0.75 | Great Britain | 0.65 | Greece | 0.70 |
| Ireland | 0.59 | Taiwan | 1.00 | Czechoslovakia | 0.75 | Italy | 0.52 | Austria | 0.61 |
| Australia | 0.57 | Malaysia | 0.92 | Iraq | 0.74 | Mexico | 0.50 | Brazil | 0.52 |
| Kenya | 0.57 | Laos | 0.90 | India | 0.73 | Brazil | 0.41 | Spain | 0.45 |
| India | 0.54 | Thailand | 0.78 | Algeria | 0.64 | Panama | 0.33 | Switzerland | 0.43 |
| UAE | 0.50 | Kuwait | 0.61 | Congo | 0.64 | France | 0.28 | Iran | 0.40 |
| Nigeria | 0.49 | Australia | 0.54 | Hungary | 0.63 | Philippines | 0.26 | India | 0.38 |
| France | 0.47 | Paraguay | 0.50 | Guinea | 0.62 | S. Korea | 0.25 | Togo | 0.38 |
| Botswana | 0.46 | Peru | 0.45 | Afghanistan | 0.62 | Colombia | 0.21 | Peru | 0.35 |
| Canada | 0.40 | India | 0.44 | Finland | 0.46 | Iran | 0.21 | Argentina | 0.32 |
| Netherlands | 0.38 | Great Britain | 0.43 | Rumania | 0.44 | Australia | 0.20 | Great Britain | 0.30 |
| Gambia | 0.37 | Denmark | 0.40 | Somalia | 0.41 | India | 0.18 | Tunisia | 0.30 |
| Malawi | 0.31 | Canada | 0.34 | S. Yemen | 0.29 | Thailand | 0.13 | Indonesia | 0.29 |
| Uganda | 0.30 | Burma | 0.33 | Cyprus | 0.22 | Greece | 0.11 | Chile | 0.26 |
| New Zealand | 0.29 | W. Germany | 0.32 | Cuba | 0.21 | Venezuela | 0.09 | Afghanistan | 0.25 |
| Mauritius | 0.26 | Italy | 0.25 | Japan | 0.17 | Spain | 0.09 | Nigeria | 0.17 |
| Guyana | 0.24 | Kenya | 0.22 | Yugoslavia | 0.16 | Taiwan | 0.08 | Yugoslavia | 0.17 |
| Belgium | 0.23 | S. Vietnam | 0.20 | Bangladesh | 0.15 | Indonesia | 0.08 | Tanzania | 0.16 |
| Italy | 0.21 | Iran | 0.20 | France | 0.15 | Turkey | 0.04 | Ivory Coast | 0.15 |

General Observations

2.35 Comparison of the country scores in Table 2.1 indicates that the British and West German interest distributions are closest to normality, i.e., their scores tend to be distributed evenly, with no single country assuming the characteristics of a statistical outlier. Japan, the Soviet Union, and in particular, the U.S., seem to have concentrated abnormally high levels of external involvement in relatively few countries. This is indicated by the outlying positions of the U.S. and Singapore for Japan; Syria, East Germany, Mongolia, and Egypt for the Soviet Union; and Canada for the U.S. The effect of this type of distribution is that the scores for the remaining countries tend to be suppressed. This is particularly true in the case of the U.S. involvement in Canada.

2.36 The regional distribution of the 25 most prominent countries according to each of the 5 major powers is shown in Table 2.2, which also shows the percentages of this distribution. The results displayed in Table 2.2 tend to match intuitive estimates of the five major powers' predominant areas of involvement. The results clearly reflect, for example, the tripolar balance of power in Asia among the U.S., the Soviet Union, and Japan. The results for Latin America indicate that the region is of approximately equal importance to Japan, West Germany, and the U.S. Europe, like Asia, shows an evenly divided balance of interests among Great Britain, the Soviet Union, the U.S., and West Germany. However, West Germany and the Soviet Union display the strongest interests in Europe in relation to their worldwide interests. The complete absence of Africa among the regions of foremost U.S. interest, as compared with the continent's important

TABLE 2.2
 REGIONAL DISTRIBUTION OF 5 MAJOR POWERS' 25 PRINCIPAL LOCAL
 AREAS OF EXTERNAL INTEREST IN 1972

| Region | Great Britain | | Japan | | Soviet Union | | U.S. | | W. Germany | |
|-----------------|---------------|-----|--------------|-----|--------------|-----|--------------|-----|--------------|-----|
| | Distribution | | Distribution | | Distribution | | Distribution | | Distribution | |
| | No. | % | No. | % | No. | % | No. | % | No. | % |
| Africa | 9 | 36 | 1 | 4 | 5 | 20 | -- | -- | 4 | 16 |
| Asia | 3 | 12 | 13 | 52 | 9 | 36 | 11 | 44 | 5 | 20 |
| Australia* | 2 | 8 | 1 | 4 | -- | -- | 1 | 4 | -- | -- |
| Europe | 8 | 32 | 5 | 20 | 10 | 40 | 7 | 28 | 11 | 44 |
| Latin America** | 1 | 4 | 3 | 12 | 1 | 4 | 5 | 20 | 4 | 16 |
| North America | 2 | 8 | 2 | 8 | -- | -- | 1 | 4 | 1 | 4 |
| Total | 25 | 100 | 25 | 100 | 25 | 100 | 25 | 100 | 25 | 100 |

* Includes New Zealand.

** Includes Central America and Mexico.

PRESEARCH INCORPORATED

ranking from the Soviet viewpoint, indicates that hopes in the early 1960s that U.S.-Soviet cold war competition in the newly independent Black African states might be avoided have come true, if only because the U.S. has chosen not to raise its investment to offset the growth of Soviet presence. Table 2.2 indicates that the principal balancing powers in Africa are Great Britain and West Germany (and probably, even more so, France, for which relevant data have not been included).

2.37 One indication of the amount of competition that is present among the five principal powers may be attained by considering each power's proportional level of interest in a particular country. Table 2.3 has listed the 79 countries that were among the 5 major powers' 25 highest ranking nations of interest. The scores of each of the 79 countries in relation to the 5 major actors have been indicated. The absence of a score for 1 or more major powers means that the country in question was not included among the 25 top-ranking nations for the particular power(s). A total of 150 independent nations and major dependencies were included in the data base; this signifies that the remaining balance of 71 countries did not figure prominently among the 5 major powers' worldwide interests. Therefore, the potential for multiple power rivalry is either minimal or nonexistent.

2.38 An examination of Table 2.3 shows only a few instances where approximately equal amounts of major power interests intersect. Specific cases include Australia, Canada, France, Great Britain, India, Iran, Italy, Singapore, West Germany, and Yugoslavia. Most of these involve the coincidence of Western interests, e.g., Japan and Great Britain or the U.S. and Japan. The rarity of U.S.-Soviet intersection is noteworthy. It suggests that geographic areas of superpower

PRESEARCH INCORPORATED

TABLE 2.3
 INTERACTION OF MAJOR POWER MANIFEST INTERESTS IN
 SELECTED COUNTRIES IN 1972

| Country | Major Power | | | | |
|----------------|---------------|-------|--------------|------|--------------|
| | Great Britain | Japan | Soviet Union | U.S. | West Germany |
| Afghanistan | -- | -- | 0.62 | -- | 0.25 |
| Algeria | -- | -- | 0.64 | -- | -- |
| Argentina | -- | -- | -- | -- | 0.32 |
| Australia | 0.57 | 0.54 | -- | 0.20 | -- |
| Austria | -- | -- | -- | -- | 0.61 |
| Bangladesh | -- | -- | 0.15 | -- | -- |
| Belgium | 0.23 | -- | -- | -- | -- |
| Botswana | 0.46 | -- | -- | -- | -- |
| Brazil | -- | 1.37 | -- | 0.41 | 0.52 |
| Bulgaria | -- | -- | 0.75 | -- | -- |
| Burma | -- | 0.33 | -- | -- | -- |
| Canada | 0.40 | 0.34 | -- | 3.09 | -- |
| Chile | -- | 0.18 | -- | -- | 0.26 |
| Colombia | -- | -- | -- | 0.21 | -- |
| Congo | -- | -- | 0.64 | -- | -- |
| Cuba | -- | -- | 0.21 | -- | -- |
| Cyprus | 0.61 | -- | 0.22 | -- | -- |
| Czechoslovakia | -- | -- | 0.74 | -- | -- |
| Denmark | -- | 0.40 | -- | -- | 0.89 |
| E. Germany | -- | -- | 1.70 | -- | -- |
| Egypt | -- | -- | 1.56 | -- | -- |
| Finland | -- | -- | 0.46 | -- | -- |
| France | 0.47 | -- | 0.15 | 0.28 | 0.89 |
| Gambia | 0.37 | -- | -- | -- | -- |
| Great Britain | -- | 0.43 | -- | 0.65 | 0.30 |
| Greece | -- | -- | -- | 0.11 | 0.70 |

PRESEARCH INCORPORATED

TABLE 2.3 (Cont)

| Country | Major Power | | | | |
|-------------|---------------|-------|--------------|------|--------------|
| | Great Britain | Japan | Soviet Union | U.S. | West Germany |
| Guinea | -- | -- | 0.62 | -- | -- |
| Guyana | 0.24 | -- | -- | -- | -- |
| Hungary | -- | -- | 0.63 | -- | -- |
| Iceland | -- | -- | -- | 0.83 | -- |
| India | 0.54 | 0.44 | 0.73 | 0.18 | 0.38 |
| Indonesia | -- | 1.06 | -- | 0.08 | 0.29 |
| Iran | -- | 0.20 | 0.89 | 0.21 | 0.40 |
| Iraq | -- | -- | 0.74 | -- | -- |
| Ireland | 0.59 | -- | -- | -- | -- |
| Israel | -- | -- | -- | 0.69 | -- |
| Italy | 0.21 | 0.25 | -- | 0.52 | 0.92 |
| Ivory Coast | -- | -- | -- | -- | 0.15 |
| Japan | -- | -- | 0.17 | 0.73 | -- |
| Kenya | 0.57 | 0.22 | -- | -- | -- |
| Kuwait | -- | 0.61 | --- | -- | -- |
| Laos | -- | 0.90 | -- | -- | -- |
| Malaysia | -- | 0.92 | -- | -- | -- |
| Malawi | 0.31 | -- | -- | -- | -- |
| Malta | 0.60 | -- | -- | -- | -- |
| Mauritius | 0.26 | -- | -- | -- | -- |
| Mexico | -- | -- | -- | 0.50 | -- |
| Mongolia | -- | -- | 1.69 | -- | -- |
| Netherlands | 0.38 | -- | -- | -- | 0.88 |
| New Zealand | 0.29 | -- | -- | -- | -- |
| Nigeria | 0.49 | -- | -- | -- | 0.17 |
| Panama | -- | -- | -- | 0.33 | -- |
| Paraguay | -- | 0.50 | -- | -- | -- |

PRESEARCH INCORPORATED

TABLE 2.3 (Cont)

| Country | Major Power | | | | |
|-------------|---------------|-------|--------------|------|--------------|
| | Great Britain | Japan | Soviet Union | U.S. | West Germany |
| Peru | -- | 0.45 | -- | -- | 0.35 |
| Philippines | -- | -- | 0.99 | 0.26 | -- |
| Poland | -- | 1.13 | -- | -- | -- |
| Romania | -- | -- | 0.44 | -- | -- |
| Singapore | 1.41 | 1.80 | -- | -- | -- |
| Somalia | -- | -- | 0.41 | -- | -- |
| S. Korea | -- | 1.01 | -- | 0.25 | -- |
| S. Vietnam | -- | 0.20 | -- | 1.47 | -- |
| S. Yemer | -- | -- | 0.29 | -- | -- |
| Spain | -- | -- | - | 0.09 | 0.45 |
| Swaziland | 0.65 | -- | -- | -- | -- |
| Switzerland | -- | 1.03 | -- | -- | 0.43 |
| Syria | -- | -- | 2.07 | -- | -- |
| Taiwan | -- | -- | -- | 0.08 | -- |
| Tanzania | -- | -- | -- | -- | 0.16 |
| Thailand | -- | 0.78 | -- | 0.13 | -- |
| Togo | -- | -- | -- | -- | 0.38 |
| Tunisia | -- | -- | -- | -- | 0.30 |
| Turkey | -- | -- | -- | 0.04 | 1.31 |
| Uganda | 0.30 | -- | -- | -- | -- |
| UAE | 0.50 | -- | -- | -- | -- |
| U.S. | 0.89 | 2.78 | -- | -- | 0.70 |
| Venezuela | -- | -- | -- | 0.09 | -- |
| W. Germany | 0.40 | 0.34 | -- | 1.55 | -- |
| Yugoslavia | -- | -- | 0.16 | -- | 0.17 |
| Zambia | 0.71 | -- | -- | -- | -- |

competition either involve proportionately minimal investments or that they are regional, rather than local. The virtual absence of co-occurring major power interests is noticeable in the countries that border one of the power's frontiers. In the case of the Soviet Union, for example, the exceptions to this phenomenon are Afghanistan, Iran, and Turkey; in all the other buffer-states, Soviet involvement not only predominates but is virtually exclusive. It is important to note that Iran and Turkey are two countries where the Soviet Union has made particularly strenuous efforts to at least diminish, if not replace, U.S. predominance. The U.S. interests in Canada and Mexico clearly outrank those of the other powers. This situation is even more prominent if Iceland is considered part of the eastern periphery of the U.S. Where two powers are in close proximity to each other, as Great Britain and West Germany are, a strong intersection of interests tends to take place in the nearby countries. Important British and West German interests meet in France and the Netherlands. Interestingly, Great Britain has the predominant interest in Belgium and, unlike West Germany, has no appreciable involvement in Denmark. This coincidence may reflect the long-standing historical relationships that exist between Great Britain and Belgium and West Germany and Denmark.

2.39 With the exception of France, the Soviet preoccupation with Europe is concentrated exclusively in its eastern half. Conversely, manifest Western interests in Eastern Europe are lacking, with the exception of a significant West German presence in Yugoslavia. Coincidentally, France and Yugoslavia were the first nations to break away from Western and Eastern bloc politics, respectively.

PRESEARCH INCORPORATED

2.40 The outstanding feature of the intersection of multiple power interests, as shown in Table 2.3, is that the coincidence of U.S. and Soviet interests appears to take place predominantly on a regional rather than subregional level. Thus, important U.S. and Soviet interests primarily confront each other not within one country but across the border of adjacent allied countries, such as West and East Germany, Israel and Egypt-Syria, Iran and Iraq, and Panama and Cuba. Local intersections of U.S. interests involve Western allies, including Japan in East Asia, Southeast Asia, Latin America, and West Germany and Great Britain in Western Europe.

2.41 The regional character of the intersection of U.S. and Soviet interests indicates that a superpower will generally avoid large-scale involvement in countries that have already been preempted by the interests of its opponent. One of the implications of this phenomenon for U.S. policy planning is that concern over future Soviet external engagements should probably focus on areas where the U.S. has little demonstrable interest. As indicated in Table 2.3, these areas involve Subsaharan Africa, and, to a lesser extent, the Indian Ocean and Latin America.

FINDINGS ON SOVIET MARITIME BEHAVIOR

2.42 The analysis of the role of Soviet naval and merchant marine port call activity within the framework of overall Soviet external involvement in the Third World showed quite distinct regional variations. Naval presence was found to be an important function of the Soviet fleet in the Middle East-North African region and along the West African coast. No such role was evident along the Indian Ocean periphery.

PRESEARCH INCORPORATED

In addition, it was discovered that the pattern of Soviet naval port visit activity in the Middle East-North Africa region is closely related to the flow of Soviet merchant marine traffic. This occurrence might be evidence of a heightened Soviet interest in some form of sea control in this particular area.

III. CONCEPT OF NATIONAL INTEREST

GENERAL

3.1 This section expands on one of the basic premises of this study, i.e., that the scope and character of a country's interests abroad may be examined most fruitfully by analyzing the observable and measurable characteristics of its day-to-day international involvements.

3.2 The most widely used explanation of national interest as a set of abstract national goals or aspirations that should guide foreign policy suffers from a degree of ambiguity and broadness that prevents it from being employed as a useful, analyzable policy construct. Instead, it is argued that for both theoretical and policy-operational reasons, the notion of a country's stake abroad should be addressed in terms of the empirically evident structure of its actual involvements--public or private, commercial or military.

NATIONAL INTEREST AS A POLICY CONSTRUCT

3.3 The term "national interest" is simultaneously one of the most omnifarious and least understood concepts in the field of international relations. To numerous analysts it is the self-evident motivation of all international behavior, requiring little, if any, analytic explanation or justification.

PRESEARCH INCORPORATED

Morgenthau, in his "realist" theory of international politics, a theory that has influenced the actions and beliefs of a generation of post-World War II students and American policy-makers, declared that national interest "is the perennial standard by which political action must be judged and directed" and that it is "the essence of politics and is unaffected by circumstances of time and place." ^{1/} Grant Hugo, a prominent British writer, agreed and, quoting Lord Strang, wrote: "Of all the considerations relevant to foreign policy the national interest is most likely to be taken for granted as part of that 'large area of common ground', which 'does not need to be explained or demonstrated.'" ^{2/}

RECENT ATTEMPTS AT CLASSIFYING NATIONAL INTERESTS

3.4 International developments in recent years, in conjunction with the desire by policy analysts to add scientific rigor to the discipline of international relations, have led to a growing awareness that the concept of national interest substantially lacks its supposed self-evident quality. James N. Rosenau has summarized some of the analytic limitations of the concept:

One is the ambiguous nature of the nation and the difficulty of specifying whose interests it encompasses. A second is the elusiveness of criteria

^{1/} Hans Morgenthau, Politics Among Nations: The Struggle for Power and Peace, 4th ed., New York, Alfred A. Knopf, 1967, pp. 8-9.

^{2/} Grant Hugo, Britain in Tomorrow's World: Principles of Foreign Policy, New York, Columbia University Press, 1969, p. 60.

for determining the existence of interests and for tracing their presence in substantive politics. Still another confounding factor is the absence of procedures for cumulating the interests once they have been identified. This is in turn complicated by uncertainty as to whether the national interest has been fully identified once all the specific interests have been cumulated or whether there are not other, more generalized, values which render the national interest greater than the sum of its parts. ^{3/}

3.5 The renewed national awareness of the distinction between the attainable and merely desirable ends of foreign policy has occasioned a flurry of scholarly writings that attempts to systematically break down the national interest concept into categories of relative priorities. Donald E. Nuechterlein, for instance, separated the U.S. national interest into "basic national interests" and "transitory interests." The former he spelled out as the "relatively unchanging national interests" in national defense, the "promotion of U.S. international trade and investment," and a "peaceful international environment." ^{4/}

3.6 According to one author, transitory interests are defined as follows:

^{3/} James N. Rosenau, The Scientific Study of Foreign Policy, New York, The Free Press, 1971, p. 243.

^{4/} Donald E. Neuchterlein, United States National Interests in a Changing World, Lexington, Kentucky, The University Press of Kentucky, 1973, pp. 7-9.

PRESEARCH INCORPORATED

...the degree of interest the United States feels in specific issues relating to its three basic national interests, and with the basis for determining which threats are so important to its defense, economic, or world-order interests that it would contemplate the use of armed force to protect them against encroachment by a foreign power. ^{5/} (Emphasis added.)

Put differently, Neuchterlein used the term transitory to emphasize the varying amounts of attention that certain issues generate at different times from decision-makers; it is used as a perceptual criterion.

3.7 Transitory interests of decreasing importance, Neuchterlein concluded, may be classified as "survival," "vital," "major," or "peripheral" interests, with each tier denoting the prevailing willingness of the government to use military force in its protection. ^{6/}

3.8 Ralph N. Clough spoke of the basic U.S. interests in survival, economic prosperity and "an international environment favorable to these interests." ^{7/} He observed that, while most people agree on the validity of these broad principles, dissension arises over their application, i.e., the circumstances that might justify the use of military force.

^{5/} Ibid., p. 10.

^{6/} Ibid., pp. 10-11.

^{7/} Ralph N. Clough, East Asia and U.S. Security, Washington, D.C., The Brookings Institution, 1975, p. 28.

The author argued for the existence of four "clusters of interest," each of which may be of "such great importance" that, if imperiled, the "use of U.S. forces to protect them must be seriously considered." ^{8/} He labeled the individual clusters general, intrinsic, derived, and created interests. General interests, he explained, relate to issues that impinge on U.S. military security directly. Examples are the U.S. economic stake in a country, traditional ties with foreign peoples, and the contribution of foreign bases to U.S. security.

3.9 Derived interests in particular countries, according to Clough, flow from either general or intrinsic interests in third countries. For example, the initial U.S. interest in Korea stemmed largely from the peninsula's perceived strategic importance to the safety of Japan.

3.10 Finally, Clough used the term created interests to define those policy actions (e.g., the conclusion of a treaty or the deployment of U.S. forces on foreign territory) that create an expectation of U.S. willingness to use force. He observed that though the original rationale for such actions may be forgotten in time, the actions themselves tend to frequently acquire a raison d'être. He wrote:

Once created, such interests are hard to extinguish. Furthermore, they tend to breed other interests. To protect existing interests, new commitments either implicit or express tend to be made in nearby areas. ^{9/}

^{8/} Ibid., p. 29.

^{9/} Ibid., p. 30.

NATIONAL INTEREST AS AN OPERATIONAL PROBLEM

3.11 Despite these and other writers' attempts to systematically distinguish among the various aspects and priorities of the idea of national interest, it is difficult to fit the complexities of day-to-day foreign policy into neat compartments of graduating interests and nearly impossible to systematically formulate and implement foreign policy according to such a set of rigorously defined priorities. Although it is conceptually feasible to separate out the national interest in matters of survival, the interdependence and origins of a host of less-than-survival concerns have frequently become so obscure as to virtually preclude their systematic ranking against some measure of their relative importance to the U.S. interest and, by extension, the U.S. willingness to use military force for their protection.

3.12 Granting the existence of an "objective" interest in national survival, clear demarcation of national interests is further complicated by the widely acknowledged subjective quality of the concept. It is extremely difficult to affirm its existence independent from the actions of national decision-makers. Instead, as Edgar Furniss and Richard Snyder stated 20 years ago: "The national interest is what the nation, i.e., the decision-maker, decides it is." ^{10/} (Emphasis added.)

3.13 The subjective attribute of the national interest is enhanced by the disputable meaning of the adjective "national."

^{10/} Edgar S. Furniss and Richard L. Snyder, An Introduction to American Foreign Policy, New York, Rinehard, 1955, p. 17.

PRESEARCH INCORPORATED

It has been argued quite persuasively that, since only a small minority of the population tends to have any regular opportunity or inclination to influence the policies of the national government, decisions ostensibly predicated on the national interest tend to consciously or unconsciously reflect the particular concerns of this small minority. Indeed, Ernst Haas and Allen White went so far as to assert that "the concept of the national interest means little more than the claims of other states which correspond to the specific aims of ruling groups." ^{11/} (Emphasis added.)

3.14 This is not to say that the resultant policies are necessarily at variance with the wishes or needs of the population at large. On the contrary, it can be argued, for instance, that the interest on the part of the governing elites in the industrialized countries in "international stability" to secure profitable trade and overseas investment conforms with the masses' interest in economic welfare and that, conversely, instability through conflict or nationalization of property would have the cumulative effect of lowering the general population's standard of living. ^{12/}

^{11/} Ernst B. Haas and Allen S. White, Dynamics of International Relations, New York, McGraw-Hill Book Co., Inc., 1956, p. 45.

^{12/} This argument, of course, invites the retort that it is incompatible with the national interest to rely on inherently precarious foreign assets in the first place; instead, the national interest demands long-term independence from the unpredictable actions of foreign states. The current call in the U.S. for "energy independence"--and hence the negation of "oil intervention"--is an example.

3.15 It seems reasonable to assert that what is generally disposed of as the national interest is, in fact, a complex arrangement of the sometimes conflicting, sometimes complementary demands and desires on the part of multiple, unequally represented domestic interest groups. Pierre Renouvin and Jean-Baptiste Duroseke reflected on the "clash of interests" that constitutes the domestic framework for foreign policy:

We see infinitely complex and diverse societies around us, divided not only into "classes" but also into "interest groups," and we constantly observe that the aspirations of these classes and groups conflict. What common denominator can be found between the demands of those Englishmen in 1846 who wanted the Corn Laws upheld, and those of consumers who were lured by Richard Cobden's propaganda in favor of cheap bread? Or between shareholders of a company that supported the conquest or retention of a colony, and the soldiers and their families, who were little disposed to risk death and bereavement for the sake of financial profit? Within one and the same state, contradictions among the interests of groups and individuals is such that one is hard put to admit that objectively a national interest exists. (Emphasis in the original.) ^{13/}

3.16 The often heard criticism that the U.S. (or any country, for that matter) seems to frequently pursue mutually exclusive international objectives, thereby demonstrating the lack of a coherent foreign policy framework, is partially

^{13/} Pierre Renouvin and Jean-Baptiste Duroseke, Introduction to the History of International Relations (trans. Mary Ilford), New York, Praeger, 1967, pp. 260-61.

PRESEARCH INCORPORATED

explained by this plurality of motives on the part of those who affect the country's overseas activities, rather than by the unity of national interests. It should also be noted that students of international affairs tend to ascribe to other countries purposes and priorities similar to those that are thought to underlie U.S. international behavior, thereby assuming implicitly that the conflux of, for instance, Soviet domestic interests is roughly equivalent to its U.S. counterpart.

3.17 The comparative foreign policy researcher who attempts to distill the notion of the national interest into an operationally useful and analyzable construct is confronted with these dilemmas:

- a. No readily available, operationally relevant outside measure exists for classifying and rank-ordering nonsurvival interests. The study of the national interest simply lacks the tools or insights needed to validate a priority list, however carefully compiled, of a country's national interests abroad.
- b. No agreement exists on the dividing line between the national interest and the interests of particular domestic elites or pressure groups. This means that the analyst who takes a "national" view of the national interest risks omitting particular

PRESEARCH INCORPORATED

concerns that, under certain circumstances, may constitute a critical driving force behind a nation's foreign policy.

- c. A widespread confusion prevails in use of the national interest as a general abstraction on the one hand and as a concrete, identifiable activity on the other. For example, the U.S. has an interest in its international investment position because its citizens own overseas property. The U.S. may also have an interest in a continuing rate of return on its overseas investments, because it is on this that the national prosperity may in part depend. The first kind of interest is concrete and empirically verifiable; the second provides a specific motive not necessarily inherent in the first (e.g., the overseas investor may only want to make a tax loss). Moreover, motivations frequently change over time and are therefore much more difficult to verify objectively. The first kind of interest may be termed a concrete stake, while the second may be labeled an abstract attitude.

3.18 These three major complications, which have bedeviled the development of an operationally pertinent national

interest concept, suggest that a most fruitful approach may be to limit analysis to the de facto evidence of a nation's overseas activities, rather than to a necessarily arbitrary a priori set of preferred national goals and objectives. In a negative sense, this approach has the advantage of avoiding the issues listed above, while at the same time it is supported by a number of practical considerations.

ROUTINE CHARACTER OF MOST FOREIGN POLICY

3.19 Although most governments presumably have a vision of what would constitute a desirable state of international affairs and spend varying amounts of attention in formulating national goals accordingly, most foreign policy appears to possess little relationship to a deliberate attempt at their implementation in a coherent and systematic fashion. One reason for the failure of a consistent, discernible link between national goals and national policy is the lack of specificity that characterizes most (usually broadly stated) national objectives. Michael J. Brower thus concluded the following on the operational guidance provided by announced national goals:

...what do [the goals used] tell us about guiding the nation's foreign policy? Unfortunately, nothing very specific. The goals are all too general, too vague, too subject to varied interpretations and definitions to serve as more than the most general of policy guides. Practically any conceivable policy from appeasement to invading a neighbor to building

PRESEARCH INCORPORATED

hydrogen bombs can be and has been carried on by various nations under the banner of one of these terms. ^{14/}

3.20 One foremost theorist of international relations, K. J. Holsti, went one step further when he all but denied the existence of systematic, goal-directed planning by national decision-makers:

...we should not assume that foreign ministers and diplomats spend all their time carefully formulating logical and coherent sets of collective or private goals to pursue systematically through the rational ordering of means to ends. [Rather, the] work of a foreign office frequently appears to develop in a completely random fashion, with no discernible relationship between decisions arrived at and policies conducive to the achievement of collective goals. ^{15/}

3.21 Most of the work of foreign ministries and other agencies concerned with the nation's international role is concentrated on routine matters, i.e., the day-to-day protection and furtherance of the country's ongoing participation in the international system. To the ministry of commerce, this year's trade statistics are the national interest; to the defense ministry, the retention of overseas bases are a routine concern; to the foreign ministry, the maintenance of

^{14/} Michael J. Brower, The U.S. National Interest--Assertions and Definitions, Cambridge, Massachusetts, MIT Press, 1959, p. 206.

^{15/} K. J. Holsti, International Politics--A Framework for Analysis, 2d ed., Englewood Cliffs, N.J., Prentice-Hall, Inc., 1972, pp. 131-32.

friendly diplomatic relations make up a large part of its activities. Accordingly, contemporary relations with foreign countries tend to be evaluated and acted on in terms of the prevailing state of interaction and not with reference to some set of broad, ideal, long-term goals. Only in times of rapid international change, crisis, or critical domestic developments will the issue of the national interest undergo critical debate, will premises and assumptions be scrutinized, and will a country's international role be reconsidered. It is under these exceptional circumstances that the actuality of national involvement will be measured against the "ideal" purpose of a country's role in the world, criteria and perceptions other than the routine configuration of international involvements will be brought to bear and what Rosenau has termed "convention-breaking" policy decisions will be made. ^{16/} In the meantime governments tend to respond to and act on their "real world" interests (i.e., the demands and pressures of their immediate involvements with other countries) rather than to act with reference to some long-range national strategy.

3.22 Evan Luard, a member of the British Parliament, has commented on this phenomenon. Because his statement is pertinent to the issue at hand, it has been cited at length:

The evidence suggests that very many decisions are made without any regard, certainly without conscious regard, to long-term objectives. Probably many governments will rarely formulate explicitly ultimate goals of this type; for this reason alone their influence on officials or statesmen is reduced.

^{16/} See James N. Rosenau, op. cit., pp. 292-97.

PRESEARCH INCORPORATED

Even when there are occasional attempts to formulate such goals, it is unlikely that they have any direct influence, though they may be strengthened as unconscious motives. The decision on how to respond to a particular diplomatic note, how to vote on a particular resolution, whether to ratify a particular convention, and still more the far larger number of smaller decisions that are arrived at within foreign offices every day will be influenced far more by other, and short term objectives.

These more immediate objectives might include the need to retain the friendship of a particular ally; the need to promote relations with a particular country or type of country; the desire not to exacerbate relations with another; the need to promote the interests or cohesion of a particular alliance and to frustrate the interests of another; the need to promote particular, rather than general interests, economic and political, of the nation and its nationals; the need not to offend a particular interest group or governing party at home. Perhaps the most important and common of all such aims is simply the need to respond to the existing situation, to find a way forward from, or a solution to the particular problem or state of affairs immediately faced. Though some of these goals may originally have been related, more or less closely, to the attainment of the long-term objectives, they may increasingly become ends in their own right, pursued without regard to their original instrumental purpose....

Other factors will influence national conduct. The tradition of policies undertaken in the past may continue to exert influence, even though consciously they are no longer regarded as goals.

PRESEARCH INCORPORATED

The political sympathies, and personal characteristics of governing groups and officials will exert an influence. Policies influence each other. Sometimes one objective will eliminate another....Sometimes goals that are contradictory, or at least conflicting will be pursued simultaneously. It is the sum total of the actions of a state that may be taken as evidence of its collective motives. ^{17/} (Emphasis added.)

POLITICAL RELEVANCE OF INTEREST IN ACTION

3.23 The second consideration that supports the use of a country's manifest international occupations as a useful numerator of its national interests is the proposition that national goals do not become politically significant until they have been translated into action. According to international relations theorist Joseph Frankel: "Values reach their full political significance only in action, when the statesman actively applies them to his image of the environment." ^{18/} Charles A. Beard's observation in his classic text, The Idea of National Interest, echoes this sentiment:

The question--What is the national interest?--can be answered, if at all, only by exploring the use of the formula by responsible statesmen and publicists and by discovering the things and patterns of conduct...

^{17/} Evan Luard, Conflict and Peace in the Modern International System, London, University of London Press, Ltd., 1970, pp. 33-34.

^{18/} Joseph Frankel, International Relations, 2d ed., New York, Oxford University Press, 1969, p. 39.

PRESEARCH INCORPORATED

embraced within the scope of the formula. 19/ (Emphasis added.)

3.24 The substance of diplomatic interaction affirms the political impact of values in action or through conduct, rather than by declaratory fiat. States rarely react to or confront each other over broad declarations of intent alone but, instead, tend to await the evidence of their actual implementation (hence the criticism of so-called "crisis diplomacy"). Indeed, a reverse process appears to prevail, where other countries' objectives and motivations become foremost matters of national concern and inquiry primarily in the wake of observed policy actions. Thus, the Soviet Union's self-proclaimed mission to spread "socialist equality" becomes an active U.S. policy concern to the extent that Moscow's manifest behavior, e.g., in the form of military assistance or economic aid, is perceived as evidence of this goal. Indeed, the perceived underlying purpose behind aid extension may be less important than the fact of its provision per se.

3.25 Nation-states, then, tend to define their own and others' situations with reference to the hard evidence of their respective preoccupations and involvements.

APPLICATIONS

3.26 A major operational advantage of studying national interest on the basis of empirically evident information on

19/ Charles A. Beard, The Idea of the National Interest, New York, Macmillan, Inc., 1939, p. 20.

national involvements, rather than on a set of arbitrarily defined national goals, is that most nations tend to operate in the international system with a set of roughly qualitatively similar activities. Thus, all nation's engage in international trade, exchange diplomatic representations, conclude treaties, participate in international tourism, etc. Moreover, the more powerful countries that concern this study have a number of additional types of international involvement in common. These include economic and military assistance, overseas private investment, the extension of military protection to weaker states, sale of armaments, and large cultural exchange programs. 20/

3.27 Not only are most of the above phenomena measurable, but, more importantly, their international scope allows the analyst to begin comparing nations on the basis of a consistent and explicit series of criteria of international interests. The potential application of this kind of comparative data is varied.

3.28 From the perspective of the study of comparative foreign policies, data of this type should allow the researcher to

20/ Kenneth N. Waltz has commented on an "imitative" process that seems to take place among the major countries: "Competition produces a tendency toward the sameness of the competitors, with those who are unable to keep up simply falling by the wayside....Contending states imitate the military innovations contrived by the country of greatest capability and ingenuity....The effects of competition are not confined narrowly to the military realm. Something that might be called socialization to the international system also occurs." Steven L. Spiegel and Kenneth N. Waltz, editors, Conflict in World Politics, Cambridge, Mass., Winthrop Publishers, Inc., 1971, pp. 472-73.

investigate a variety of propositions or generate new hypotheses about the national "styles" in which the great powers apportion their interest stakes outside their national boundaries. For instance, the analyst may wish to focus on the particular mix of international stakes that might typify different countries. In this manner, he may be able to shed light on national differences in the degree of cohesiveness among political, military, and economic tools of foreign policy. Patrick J. McGowan's study on Soviet interaction with the African nations in the early 1960s, for instance, found a close correlation between Soviet economic and military assistance disbursements and concluded that "economic and military foreign aid from communist states to African states is a coordinated, politically motivated instrument of foreign policy."^{21/} A legitimate research question is whether the coherence between Soviet (African) aid programs is unique or if, in fact, other major aid disbursers display similar patterns. Moreover, it may be questioned whether the integration of Soviet aid policy is consistent throughout the underdeveloped world or if perhaps McGowan's findings for the early 1960s have been outdated by more recent developments in Soviet involvement "style." Furthermore, a highly relevant and practical issue in this regard is the extent to which expanding Soviet worldwide commercial activities tend to be accompanied by political inroads. Until recent years, the consensus was that Soviet trade patterns were primarily politically motivated and that Moscow used the extension of favorable trade arrangements mainly to establish political

^{21/} Patrick J. McGowan, "Africa and Non-Alignment: A Comparative Study of Foreign Policy," International Studies Quarterly, Vol. 12, No. 3, September 1968, p. 282.

beachheads, which were further expanded by the provision of extremely low-interest, long-term credit terms. Today, on the other hand, it is repeatedly asserted that the Soviet Union is becoming increasingly "commercialized," and perceives its international trade position more and more on its individual merits, i.e., to gain foreign currency reserves, to acquire Western technology, or to simply import commodities that are produced more cheaply elsewhere.

3.29 Additional comparative foreign policy questions that are suggested include, for instance, the issue of Japan's alleged separation of trade from politics. It is envisaged that the aggregate empirical data used in the study will help clarify and define conceivable modifications in this policy since the "Nixon shokku" of 1970 and, even more so, following the Arab petroleum embargo of 1973-1974.

3.30 On a wider level, international developments over the last 10 years or so emphasize the appropriateness of taking a systematic inventory of what appears to be a qualitative rearrangement of the largely bipolar structure of international involvements that characterized the first two decades after World War II. The distinction between "Western" and "Communist Bloc" interests has lost a great deal of relevance today. Instead, numerous thoughtful observers have commented on the acute sense of nationalism that seems to dominate contemporary interstate relations. "Allied" diplomacy has been replaced by unilateral French, West German, or Japanese foreign policy initiatives, which, in conjunction with the shift in the relative distribution of international power, are having a significant effect on the integrity of areas of the world that were hitherto viewed as the "privileged preserves" of a single dominant power.

3.31 Just a cursory examination of international affairs during the last decade provides ready examples of the diffusion of traditional areas of single-power or bloc authority and influence. Thus, recent years have witnessed high West German private investments in Brazil, French arms sales to Peru, Japanese economic assistance personnel in the former French colony of Mauritania, U.S. arms sales to Kuwait, and Soviet military advisers in Iraq. Indeed, it is conceivable that a systematic analysis of the extent and rate of Japan's and Western Europe's widening circles of nonmilitary involvements will seriously question the validity of George W. Ball's assertion of less than 3 years ago that "Western Europe... plays only a marginal role outside Europe and Africa with a residual interest in the Middle East and nostalgic tags of empire in the Far East and Pacific." ^{22/}

3.32 Time-extended analysis of discrete involvement data may provide an extremely useful tool for identifying possible geographic and functional trends in the structure of multiplying, international, great power interests. Alleged U.S. "disengagement" may be tested against other countries' activities in an effort to clarify perhaps the "power vacuum" theory of international politics.

3.33 A systematic analysis of comparative great power interests, explicitly based on discernible indicators of manifest involvement, ought to contribute significantly to operational policy requirements. Given the earlier proposition that most ongoing foreign policy activities are both determined and

^{22/} George W. Ball, "The Superpowers in Asia," Adelphi Papers, London, No. 91, November 1972, p. 1.

constrained by the prevailing framework of a nation's foreign involvements, an explicit description of the international hierarchy from the individual egocentric perspectives of the great powers ought to identify the current policy priorities of the great powers. This should help define those countries and areas in the world where local upheavals, regime changes, or military conflicts are most likely to stimulate great power concern and possible political or military initiatives. Conversely, the availability of comprehensive empirical data should provide the critic of current national policy with the factual tools needed to argue more effectively the alleged misallocation of national interests and policy planning resources.

3.34 A systematic analysis of the structure of relative cross-national rankings ought to sharpen the policymaker's perception of the concerns of other nations; it should serve to improve his understanding of the limitations, opportunities, and risks that are imposed on or are available to him as the natural result of other great powers' interests abroad. In the end, a national strategy might be fashioned more intelligently.

IV. CONCEPT OF INTERNATIONAL COMPETITION

GENERAL

4.1 This section expands upon the second basic premise of this study, which holds that: relations among states are characterized largely by competition; competition and conflict, military or political, are closely linked together; and the potential for competition is implicit in the intersecting foreign activities, public and private, of sovereign countries.

4.2 It is proposed, in this section, that certain changes in the international system during the past 10 or 15 years have given rise to a growing number of opportunities for international rivalry among both allies and adversaries. Some of these alterations include: (a) the shift from "bloc" politics to multipolarity; (b) the diminished credibility of the threat to use nuclear weapons; (c) the questioned utility or acceptability of military force in situations of nonmilitary confrontation; and (d) the resurgence of the importance of "traditional" means of statecraft and international "compellence," such as commodity embargoes.

INTERNATIONAL RELATIONS AS COMPETITIVE BEHAVIOR

4.3 The dominant explanation of most international politics is the prevalence of competition among nation-states. Indeed,

most students of international relations maintain that the very existence of a world geography divided into autonomous nation-state units originates with, and is the logical product of, the competitive interaction among organized groups of people. Thus, according to one of the foremost authorities of the discipline:

International politics...owes its existence to the division of mankind into groups that feel themselves different from one another and that obey no common power. It, therefore, operates under the permanent threat of violence....In international relations, there is an essence of political behavior, what philosophers have called the "state of war," a competition without any restraints other than those that this state itself ceaselessly creates and destroys. ^{1/}

4.4 The object of international competition has been variously defined as--just to name a few--power, influence, security, access to raw strategic materials, export markets, souls, and, in its simultaneously most embracing, as well as least explicit, form--national interests.

4.5 The dictum that the search for security by one nation implies the future insecurity of others evidences the prevailing belief that nation-states can acquire and retain "international assets" only at the expense of others. Media such as power, political allegiance, investment opportunities, etc., are perceived in short supply so that countries--consciously or unconsciously--must be constantly involved in a never-ending competition to maintain and expand their share of scarce international resources.

^{1/} Stanley Hoffman, The State of War, Frederick J. Praeger, Inc., New York, 1962, p. 27.

ROUSSEAU'S THEORY OF INTERNATIONAL CONFLICT

4.6 One of the most powerful explanations of the continued predominance or rivalry for scarce international assets, despite the frequently professed benefits of cooperative action, and the elimination of international warfare that is expected to logically result therefrom, was advanced by Jean Jacques Rousseau almost 200 years ago. Armed conflict, he claimed, originates in the interdependence and contacts among nation-states and will remain inevitable simply because of the lack of authoritative mechanisms or institutions to prevent its occurrence. The intersection of one nation's activities with another's and the subsequent creation of mutual dependence, he argued, will create and magnify incompatibilities and suspicions, which, if not tempered by what Rousseau terms the "apparent" interest in mutual restraints, will eventually resolve into armed hostilities.

4.7 The distinctive mark of Rousseau's interpretation of international relations is his definition of war as arising from "links between things rather than between men."^{2/} In this, he rejects the Hobbesian thesis that the persistence of international conflict logically results from the failure to extend the binding authority which, as Hobbes asserted, served to eliminate the domestic "war of all against all" that prevailed in the original "state of nature." No, Rousseau claims, the "state of nature" remained a peaceful condition as long as human beings lived in relatively small groups isolated from each other. The state mechanism he viewed as a necessary evil, which became mandatory only when

^{2/} Ibid, p. 63.

groups increased in size and expanded their intergroup interdependence and activities, which then, in the absence of regulatory mechanisms, too frequently resulted in conflict. Similarly, according to Rousseau, it is not an inherent lust for power or aggrandizement that drives nations to war (as the Hobbesians would have it), but rather the expanding web of multinational involvements and activities. Just as Rousseau proposed to do away with the necessity of state "tyranny" in domestic affairs by redistributing a nation's population into small, self-sufficient communities, so he urged that internecine warfare could only be eliminated if nation-states lived in self-imposed insulation from one another. Although he did not refer to the Rousseauian argument explicitly, Ronald Steel drew the deductively correct conclusion that a division of the world into a set of mutually recognized spheres of influence that "would grant to the great powers certain rights in areas they deem essential to their own security," would be inherently more stable. ^{3/}

4.8 The competitive nature of international relations, therefore, is integral to the nation-state structure of the international system, and it follows, according to J. David Singer, that "there seems to be only the barest correlation between how a nation pursues its interests and the nature of its leadership or its socio-political institutions...." ^{4/}

^{3/} "A Spheres of Influence Policy," Foreign Policy, No. 5, Winter 1971-1972, p. 111.

^{4/} J. David Singer, "Inter-Nation Influence: A Formal Model," James N. Rosenau, ed., International Politics and Foreign Policy, rev. ed., New York, The Free Press, 1969, p. 383.

DECISION-MAKER'S PERCEPTION OF INTERNATIONAL POLITICS AS COMPETITIVE BEHAVIOR

4.9 Abundant evidence exists that both policy analysts and national decision-makers do indeed perceive international politics as a competitive, zero-sum, "game." One author thus asserted matter-of-factly, that the "disappearance of the Russians from the Sudan (in the early 1970s) was a net gain for Washington...." ^{5/} (Emphasis added). Cottrell and Burrell spoke in a similar vein in their recent study of the Indian Ocean: "...it must be restated that the mere entry of any Soviet influence (in this case in the form of naval activity) into an area that was previously an exclusively Western domain constitutes a loss to the West...." ^{6/} (Emphasis added.) Finally, U.S. decision-makers' adherence to the competitive explanation of international politics is implicit in former President Nixon's warning to the Soviet Union that the U.S. had a "strong interest in preserving and developing our ties with the Arab world," and that, "attempts at exclusion of predominance are an invitation to conflict, either local or global." ^{7/}

^{5/} J. Bowyer Bell, The Horn of Africa: Strategic Magnet in the Seventies, New York, Crone, Russak and Co., Inc., 1973, pp. 40-41.

^{6/} Alvin J. Cottrell and R. M. Burrell in introduction to Part V "Major Power Interests and Policy"; Cottrell and Burrell, eds., The Indian Ocean: Its Political, Economic, and Military Importance, New York, Frederick J. Praeger, Inc., 1972, p. 334.

^{7/} "U.S. Foreign Policy for the 1970's--Shaping a Durable Peace," Report to the Congress, May 5, 1973, Washington, D.C., GPO, 1975, p. 138.

WHY GREAT POWERS GET INVOLVED

4.10 The desire or drive to "be involved" is characteristic of the great powers. Historical experience reveals that nation-states tend to expand or contract their network of international activities concomitant with their respective increase or decrease in national capabilities. Concerned observers have become aware that the process of economic, political, or military expansion beyond the nation's boundaries seems to have a dynamic momentum of its own, rather than being the deliberate result of a calculated series of cost-benefit decisions. The notion that Britain acquired an empire in a "fit of absent-mindedness," and the claim that international responsibility was "thrust" upon, rather than sought by, the United States illustrate the perceived "necessary" quality of expanding great power involvement. ^{8/}

4.11 Three basic explanations have been advanced for the apparent absence of rational deliberation in great power expansionist activities. These theories are described in the following paragraphs.

"Excess Energy" Theory of Expanding Involvement

4.12 The first theory rests on an analogy between "surplus" national capabilities and excess energy and explains outward

^{8/} Zbigniew Brzezinski explained a few years ago: "Our global involvement and our preponderance of power is such that our disinvolvement would create international chaos of enormous proportions. Our involvement is an historic fact--there is no way of ending it." "The Implications of Change for United States Foreign Policy," Department of State Bulletin, July 3, 1967, p. 4.

expansion as a self-generating pressure to break beyond the confinement of the nation's boundaries. According to Choucri and North:

Nation-states and empires with high lateral pressures...tend to extend their influence in search of raw materials, markets, or other needed sources...high levels of energy and surplus capital often seek outside investment opportunity even when resources are relatively plentiful...societies with high specialized capabilities, and high levels of human and mechanical energy frequently have their capabilities put to expansive use--even if it means exploring the moon. ^{9/}

4.13 J. D. B. Miller speaks in a similar vein in his observation that there "is a drive about a great power which develops as it grows in strength and confidence, and as wider areas of operations become apparent to its leaders." ^{10/}
(Emphasis in the original.)

"Incrementalist" Theory of Expanding Involvement

4.14 The second explanation of the cumulative character of a great power's worldwide involvement is based on the "incrementalist" theory of foreign policy and has been put forward, among others, by Ernst B. Haas:

^{9/} Nazli Choucri and Robert C. North, "Dynamics of International Conflict," Raymond Tanter and Richard H. Ullman, eds., Theory and Policy in International Relations, Princeton, N.J., Princeton University Press, 1972, pp. 93-94.

^{10/} J. D. B. Miller, "Unlimited Competition or Spheres of Responsibility," Adelphi Papers, No. 66: "Soviet American Relations and World Order: The Two and the Many," London, The Institute for Strategic Studies, March 1970, p. 40.

The formulation of the national interest is not a matter of continuous assessment, each phase of which can be dated. The salience of its various elements constantly changes but reformulation takes place only sporadically, when a major decision has to be made. With time, the formulation inevitably dates and, although it may remain in force in its original form for a long time, it is likely to be increasingly deviated from until the discrepancy becomes flagrant or a new assessment is called for by some sudden change. Only then is the national interest reformulated. ^{11/}

"Attraction" Theory of Expanding Involvement

4.15 Finally, some students of international relations have postulated the "attractive" quality of international power centers. Using insights derived from studies of the psychological evolution of the parent-child relationship from dependence through rebellion to interdependence, they have proposed that weaker states will automatically gravitate to those who have a surplus of capabilities. According to Marshall R. Singer:

...power, like a magnet, tends to attract. As the power of one state increases (relative to the power of other states) it tends to attract to itself those weaker states that were formerly "drawn" to other powers. ^{12/}

^{11/} Ernst B. Haas, Tangle of Hopes--American Commitments and World Order, Englewood Cliffs, New Jersey, Prentice-Hall, Inc., 1969, pp. 91-92.

^{12/} Marshall R. Singer, Weak States in a World of Powers: The Dynamics of International Relations, New York, The Free Press, 1972, p. 57. A recent study of the relationship between the efficacy of foreign aid programs and recipient perceptions of donor countries provides

Singer adds that, although economic needs may be the sole incentive for a weak country to gravitate to a great power, there

...is ample statistical evidence, however, that with regard to the relations among states, dependence in one area tends to correlate highly with dependence in other areas..., [that if] a country is highly dependent economically upon another country, the likelihood is that it will also have a high perceptual, communications, military, and political dependence as well. ^{13/}

4.16 Singer's analogy between adolescent rebellion against parental authority and the rejection (verbal or physical) by small states of great power domination points to the compound risks of international involvement. A first danger that a great power incurs while expanding its activities abroad is eventual intersection with a second great power's foreign involvements and the resultant threat of great power conflicts. The potential for conflict is compounded, in turn, by the interaction of great power involvement with local authority structures, independent of the activities of additional great powers. Concern with over-involvement can, in large

some support for the "attractiveness" theory of great power expansion in its finding that "the more powerful (militarily, scientifically, or economically) a donor (or potential donor) is perceived to be, the more desirable is that nation's aid and the more potent its economic effects are judged to be," despite recipients' mistrust of great power motivations per se. Kenneth and Mary Gergen, "Understanding Foreign Assistance Through Public Opinion," The London Institute of World Affairs, The Year Book of World Affairs 1974, New York, Frederick J. Praeger, Inc., 1974, p. 133.

^{13/} Ibid., pp. 48-49. The author holds that the opposite tends to hold true as well.

part, be attributed to the belief that the greater an overseas presence, the more likely it will be a target for local frustrations, however unrelated these frustrations may be to this presence itself. Current emphasis on the desirability of a "low profile" or "reduced visibility" in U.S. foreign policy underscores this understanding.

POLICY RELEVANCE OF EXAMINING MULTIPLE POWER INVOLVEMENT

4.17 The postulated conflict-producing attribute of intersecting international involvements suggests its high degree of relevance not only as a field for theoretical inquiry, but even more so with regard to its implications for U.S. foreign policy. The policy relevance of studying patterns of multiple power involvement is suggested by such current international interests as the emphasis on East-West "bridge-building," the search for functional areas of international cooperation and diplomatic agreement, and the replacement of strict bipolarity by an increasing number of discrete centers of international power and authority. Although these three phenomena are closely interrelated, it may be useful initially to treat them separately to get a better understanding of their pertinence to a systematic approach to the study of international involvement patterns.

Multiple Power Involvement and Bridge-Building

4.18 First, with regard to the contemporary emphasis on East-West bridge-building and the professed desirability of intensified cultural, economic, and political contacts between the Communist and non-Communist countries of the world, few, if any, systematic endeavors have been made to confirm the

empirical reality of the supposed conflict-attenuating role of such linkages. Instead, it appears to be grounded on the à priori premise that increased person-to-person and institutional contacts will lead to "better understanding," which, in turn, will ipso facto lead to peaceful relationships. On first sight, this assumption seems to seriously contradict both historical experience and the more recent record of overlapping U.S. and Soviet involvements in various regions in the world. On the face of it, it appears to be directly at odds with the argument that one of the primary motivations for the extension of a great power presence abroad is to offset or preempt similar activities by "opponents," i.e., its competitive characteristic. Accordingly, U.S. military assistance programs to the developing countries have frequently been justified on the grounds that failure to respond to requests would open the door to the Soviet Union. ^{14/}

4.19 Soviet overseas activities that intersect with an established Western presence have been perceived in a similar rivalrous light--not as contributory to the building of bridges. This understanding of Soviet behavior has been well expressed by Joshua and Gilbert in their study of Moscow's arms export policies in the developing countries:

A crucial element in Soviet arms diplomacy in Africa continues to be the objective of eliminating Western and especially American influence....But the existence of a U.S. arms aid program [is] not a necessary condition

^{14/} The growing competitiveness in recent years between the U.S. and the Western allies is emphasized by the current argument that a U.S. failure to sell arms will be taken advantage of by the French or British.

for the Soviet Union to act....As a rule, Soviet military aid policies [are] formulated with broader goals in mind than offsetting a nearby U.S. arms aid presence. They were designed to erode in general the Western position in Africa. ^{15/}

Issues Relevant to Multiple Power Involvement Behavior

4.20 In view of these two contradictory claims concerning the implications of overlapping great power activities in a third area, a systematic analysis of international involvement should examine and, hopefully, clarify the conditions under which mutual involvement will lead either away from or toward tensions and conflict. Some of the questions that might be resolved follow.

4.21 Which types of mutual involvement are most or least tension-producing? A related but perhaps somewhat different issue is whether "characteristically" different types of presence on the part of two or more great powers (e.g., commerce versus military support) is most conducive to lessening tension. Talcott Parson's notion of "cross-cutting solidarities," whereby domestic political polarization is mitigated by the overlapping group memberships of otherwise opposite political partisans, may provide a useful conceptual beacon in this regard.

4.22 To what extent is competitiveness perceived to be related to the power status of the interacting countries? Is the degree of great power rivalry in a third country related

^{15/} Wynfield Joshua and Stephen P. Gilbert, Arms for the Third World--Soviet Military Aid Diplomacy, The Johns Hopkins Press, Baltimore, 1969, p. 50.

to the relative size of their mutual involvements, i.e., will competition and tension be more pronounced the more "equal" the respective investments, and, by implication, is detente more likely when one of the powers clearly "outweighs" the others?

4.23 What, if any, is the effect of the passage of time on the competitive edge of mutual great power involvement? One author has observed:

With the passage of time and the accumulation of experience, [the superpowers] may become less responsive than before to one another's maneuvers, and less inclined to be alarmed at situations that would seem on the surface to provide preemptive openings, footholds, and opportunities for their rivals. ^{16/}

An opposite thesis holds that the longer the record of great power mutual involvement, the more intense will be their respective vested interests in a particular area, and the more watchful they will be that they are not infringed on by others.

4.24 If additional light can be shed on the above issues, an important step will have been made toward a better appreciation of the opportunities for functional areas of international cooperation and diplomatic consensus. By understanding

^{16/} Malcolm H. Kerr, "Persistence of Regional Quarrels," J. C. Hurewitz, ed., Soviet-American Rivalry in the Middle East, New York, Frederick J. Praeger, 1969, p. 241.

the nature of the relationship between different dimensions of multiple power involvements (i.e., trade versus political alignments versus development assistance) on the one hand, and the intensity of international competition on the other, areas of complementary presence, rather than competitive involvement, may be identified. Moreover, if the analysis were to suggest certain trends that imply areas of potentially intense multiple power rivalry, cooperative steps might be taken to defuse their occurrence.

INTERNATIONAL SYSTEM CHANGES AND THE POTENTIAL FOR COMPETITION

4.25 It is widely acknowledged that the main structural characteristics of the international system have evolved from East-West bipolarity to multipolarity. A number of developments over the past 15 years or so have been identified as contributory to this transformation. They include the following developments.

Reduced Credibility of the Use of Strategic Nuclear Forces

4.26 The questionable use of strategic nuclear weapons by the two superpowers in all but situations of national survival has had two corollary implications for the relative freedom of action on the part of the nonsuperpowers. First of all, it has put into doubt the worthiness of the existing superpower nuclear guarantees, thereby questioning the need and desirability of continued reliance on an (unequal) alliance relationship. France's withdrawal from the military structure of NATO and, to a lesser extent, Rumania's de facto absence from the Warsaw Pact are symptomatic of this reassessment. Also, the fading credibility of the use of nuclear force as

an extension of foreign policy has weakened some of the inhibitions on the part of the smaller powers to pursue international objectives quite at variance with the interest of the super-powers. Consequently, smaller countries may feel less compelled to accommodate to the wishes of their respective super-power guarantor or menace. The diplomatic confrontation between the U.S. and the European NATO allies over the former's 1973 Middle East resupply effort exemplifies this trend. Difficulties in U.S. attempts to formally establish a "linkage" between European security and economic issues further illustrate the allies' confidence in opposing U.S. wishes, despite implicit threats of a departure of the U.S. military umbrella.

Growing Capabilities, Relative to the U.S., of the Soviet Union, the Major Western European Countries, Japan, and China

4.27 Increased national capabilities signify a growing national confidence in the unilateral pursuit of national objectives, which, as observed previously, will tend to be translated into an expansion of the nation's activities abroad. The widening circle of international involvements on the part of a growing number of nations will necessarily result in a greater frequency of international intersections, thereby raising the possibility for international friction. This outcome is reinforced, of course, by the conditions of nuclear "noncredibility" outlined above. The growth of foreign countries' international involvements relative to those of the U.S. is most evident in trade, foreign technical and economic assistance, and, in the case of the Soviet Union, military presence in the form of advisers and base infrastructures.

Questioned Utility of Military Force in Nonsurvival Situations

4.28 It has not been too long ago since it was taken virtually for granted that commercial expansion would be almost surely followed by the extension of political and military interests (hence the notion that "the flag follows the trade"). Presently, there exists a widespread belief that military instruments of national authority have become increasingly irrelevant to the successful pursuit and security of a nation's stakes abroad, thereby possibly enhancing the usefulness of nonmilitary means and, by implication, the autonomy and flexibility of the middle-sized powers.

4.29 The industrialized countries' inability to prevent the Arab petroleum embargo or to compel the producing nations to compromise the oil-pricing policies that are creating havoc to the Western world's economies has reinforced the belief among students of the international scene that traditional means of "compellence," where the implicit threat is the use of military force, may have outlived its usefulness. Instead, more subtle international activities, such as currency and commodity agreements, international trade flows, credits, and economic assistance--tools that are available not just to the military superpowers--have been stressed as the relevant tools of diplomacy. Alastair Buchan elaborated on this development as follows:

....We have reached a period when strategic considerations are not, for the moment, dominant. Consequently, other forms of power, influence and interaction, trade, investment, political dynamism and stability, the location

of raw materials, the mediatory or revolutionary influence of deployed conventional military power, forms of influence of which the old powers by no means possess a monopoly, have acquired relatively greater significance. ^{17/}

4.30 The questioned utility of military force as a foreign policy tool may simply be a contemporary phenomenon, and, indeed, may be a peculiarly American reaction to a costly and frequently frustrating 30-year endeavor to secure a stable international system. However passing this sentiment may be, the militarily weak nations will have a strong interest in formalizing the "unconventionality" of the use of military force to resolve what they will deem to be "nonmilitary" issues. Moreover, all things being equal, a U.S. presumption against the use of military force is likely to raise the number of instances where other nations will confidently pursue policies and objectives antagonistic to the U.S. In short, a diffused international system where the participants are uncertain about the circumstances in which the U.S. (or the Soviet Union) might apply what the former Chief of Naval Operations, Admiral Zumwalt, termed "increments of American power," might be characterized by a great deal of instability.

RELATIONSHIP AMONG DIFFERENT TYPES OF FOREIGN INVOLVEMENT

4.31 An important question, particularly relevant to the future roles of the Soviet Union, Japan, and a politically

^{17/} Alastair Buchan, "The End of Bipolarity," in "East Asia and the World System, Part I: The Super-Powers and the Context," Adelphi Papers, No. 91, London, November 1972, p. 23.

integrated Western Europe, is whether and to what extent commercial and economic aid involvement tends to evolve into political and/or military links, and, conversely, whether a contraction of political-military responsibilities tends to be accompanied by a reduction in commercial stakes. In other words, is there a positive association among the several dimensions of a great power's involvement in foreign areas of the world? In the case of the U.S., both supporters and critics of the U.S. worldwide security system have argued the respective economic benefits or spoils that are thought to flow from the extension of the country's military protection abroad. Similarly, Soviet foreign commercial, cultural, political, and military activities abroad are generally held to be fully integrated in a single-minded pursuit of the extension of Moscow's power and influence.

4.32 Grant Hugo, an authority on British foreign politics, shares the belief that prosperous and expanding foreign commercial activities hinge upon a concomitant projection of the nation's political and military authority abroad: "Protection draws allegiance and allegiance draws protection," he observed, and he noted that the "loyalty to Britain of the English-speaking countries of the Commonwealth has been directly proportional to their reliance on British protection. As this declines, so has the proportionate importance of British trade and investment in these countries and so, sentiment notwithstanding, has their readiness to afford political or military assistance."^{18/} The author's argument is

^{18/} Grant Hugo, Britain in Tomorrow's World: Principles of Foreign Policy, New York, Columbia University Press, 1969, p. 82.

directly at odds with the claim by those who criticize overseas military expenditures on the grounds that there is no necessary interconnection between military and nonmilitary foreign involvement: "There is no credible argument," noted David Owen, a member of the British parliament, "to sustain the belief that a military presence can actually protect a nation's overseas trading position." ^{19/}

4.33 The lack of understanding about the precise nature of the relationship between the military and nonmilitary aspects of international involvement is demonstrated in particular by the ongoing debate over the U.S. commitment to NATO Europe. Supporters of a continued deployment of U.S. combat forces point to the importance of safeguarding U.S. commercial activities, investments, and the tens of thousands of U.S. citizens that reside on the Continent in furtherance of those interests. Opponents readily acknowledge the critical importance of these considerations but employ them to justify the redundancy of a U.S. military presence. Simon Serfaty claims:

...one may question whether it remains necessary for the U.S. to station troops in Europe in order to assure Europe of its commitment. Even if hostages continue to be required, can they not be found in the tens of thousands of tourists and other American citizens who are in Europe at any time of the year, or in the billions of dollars Americans have invested in Western Europe over the past twenty years? ^{20/}

^{19/} David Owen, The Politics of Defense, New York, Taplinger Co., 1972, p. 108.

^{20/} Andrew J. Pierre, "America and Europe in the 1970's: Integration or Disintegration," Orbis, Vol. 17, No. 1, Spring 1973, p. 100.

4.34 Evidently, the precise cost-benefit relationship between the projection of military and nonmilitary components of national involvement abroad remains an unresolved issue. Indeed the question of whether or not the extension of international security guarantees (through an alliance, military assistance, or overseas basing) does, in fact, have a significant payoff for the nation's overall international economic standing and, by inference, for its internal prosperity, is less important to the current research than the existence of the relationship between security guarantees and payoffs per se.

4.35 Japan is frequently given as the outstanding example of a nation that has been able to develop a superpower economy and pursue worldwide commercial involvement, without assuming the political and military trappings that are traditionally associated with such roles. To be sure, there is a continuing debate both within and without Japan as to when (not if) the country will assume wider political "responsibilities" commensurate with the country's economic importance. Most thoughtful observers of East Asian politics seem to agree that Japan cannot escape defining a political context for its rapidly expanding economic influence in the region. Disagreement centers on whether such a framework will be paralleled by military expansion, possibly including the deployment of nuclear weapons. As one writer of East Asian great power politics observed recently:

... the nagging question remains: In the long run is it possible for a nation as powerful economically as Japan to remain lightly armed, dependent on its [U.S.] ally for defense against powerful neighbors? Can Japan's interests in the nuclear age be protected by its modern

samurai, armed only with the briefcases of the businessman and the diplomat? 21/

The author asserted that Japanese-Chinese economic and political rivalry, rather than close cooperation, will be the more likely state-of-affairs in the near future. He cited the Chinese belief, expressed by Chou En-lai in an interview with James Reston a few years ago, that an economy as highly developed as that of Japan "was bound to demand outward expansion," and that "economic expansion is bound to bring about military expansion." 22/ Pronunciations by Japanese government leaders themselves may have contributed to Prime Minister Chou's prediction. Nakasone, the director-general of the Defense Agency under Prime Minister Sato and Minister of Trade and Industry in the Tanaka cabinet, said:

There will also be established such economic relations between these nations [of East Asia] that they will find it impossible to maintain themselves if they are alienated from our country. If this is so, Japan will have to formulate a larger-scale political plan, with the peace, development, and prosperity of various Pacific nations in mind. 23/

Japanese accommodation to the Arab position during the recent Middle East petroleum embargo in the face of strong U.S. criticism indicates Japan's new willingness to unilaterally pursue its interests if those cannot be secured by, or are incompatible with, those of its military guarantor. Presumably, as long

21/ Ralph N. Clough, East Asia and U.S. Security, Washington, D.C., The Brookings Institution, 1975, pp. 55-56.

22/ The New York Times, August 10, 1971. Cited in Ralph N. Clough, op. cit., p. 68.

23/ Nakasone, "Organization of the Democratic Party," Jiyu Shimo, February 17, 1970. Cited in Ralph N. Clough, op. cit., p. 68.

as the security of Japan's overseas economic markets and neighboring states can be protected by the U.S., and as long as such U.S. protection is not limited to American commercial advantage at the expense of Tokyo, Japan is not likely to perceive a demonstrable need to raise its own military umbrella.

INTERNATIONAL MULTIPOLARITY AND INTENSIFIED COMPETITION

4.36 The multiplication of centers of international power will, by definition, result in the multiple intersection of their respective foreign interests and activities. The potential for cross-cutting rivalries and conflicting interaction is intrinsic to overlapping multiple power stakes. Furthermore, the U.S. will find it difficult to view the former "objects" of its foreign policy as new centers and more or less equal "subjects."^{24/} The resistance by a great power to revising its estimation of a newly arrived focus of international authority is only partially the result of ingrained habits of egocentrism. Again, the very competitive structure of the international system implies that accommodation of other nations as "subjects" rather than "objects" signifies a decrease in one's own power and an attendant reduction of control over one's own security and well-being. George Liska has commented on this:

^{24/} On the distinction between countries as objects versus subjects of foreign policy, see, for instance, Baldev Raj Nayar, "Treat India Seriously," in Foreign Policy, No. 18., Spring 1975.

The American attitude to potential regional imperialists had to be dogmatically negative. Middlepower self-assertion beyond a readily discernible definite point threatened to inhibit or bar outright U.S. access to still lesser states in a region. 25/

4.37 A clearly perceptible outcome of the demise of strict bipolarity is the transformation of an essentially two-party, intense, interbloc competition in the shadow of the all-out nuclear option to one of muted and complex multiparty rivalry. The new opportunities for diplomatic confrontation among friends and allies were demonstrated clearly during the 1973 Middle East war. The cross-cutting commercial and political interests of the U.S. and its Western European security allies in the region were simply too dense and important. One country unilaterally acting in its own interests was bound to affect the others and bring to the fore otherwise submerged incompatibilities. While the principal American concern was with the security implications of Israel's military defeat and the Soviet strategic gain that would follow in the region, the Europeans were motivated by the domestic implications of losing Arab petroleum supplies.

4.38 The U.S. argument that its strategic responsibilities and power outweighed those of the allies and, therefore, justified its military initiatives during the October 1973 war, demonstrates the need to appreciate the magnitude of other countries' overseas interests from their perspective,

25/ Robert E. Osgood, et. al., "The Third World: Regional Systems and Global Order," Retreat From Empire? Baltimore, Maryland, The Johns Hopkins Press, 1973, p. 335.

i.e., relative to the sum total of their individual interests worldwide. Recalling the earlier proposition, that interests tend to expand commensurate with growing national capabilities, a large power is easily tempted to overlook what may be a comparatively minor, small country stake in absolute terms, but which may, in fact, be crucially important to the latter. In other words, a criterion of proportion needs to be applied for a thorough understanding of the foreign priorities of different sized powers. 26/

4.39 There is a second aspect to the criterion-of-proportion issue; namely, is the extent of a major power's interest in a foreign country more accurately measured in terms of the absolute value of its "investment," (i.e., compared with the absolute values invested elsewhere), or, by contrast, with reference to some sort of denominator of the country's relative size? To give a specific example: Which measure of the U.S. economic aid program to India is the better reflection of the importance Washington attaches to the country --the fact that in the aggregate India became the largest recipient of U.S. aid among the new nations, or instead, the per capita disbursement of assistance, which, parenthetically, is only half of that provided to Pakistan? Resource allocation criteria used by donor countries are probably too varied

26/ The importance of viewing the "relative value" of a country from the perspective of the power involved has been stressed by Herbert Goldhamer in his study of foreign involvement in Latin America. He noted that, "in order to judge the importance of Latin America to [the] overall foreign investment activity [of the nonhemispheric countries plus the U.S.], we need to know how much of each country's total foreign investment goes to Latin America. On this basis, it is clear that Latin America is far more important to West Germany, Japan, and Italy than it is to the other countries or to the U.S." The Foreign Powers in Latin America, Princeton, New Jersey, Princeton University Press, 1972, pp. 43-44.

and complex to arrive at a single definitive answer. It seems advisable, therefore, to use both aggregate and per capita measures to arrive at a prudent estimate of the relative priority of a target country.

RISKS OF INVOLVEMENT

4.40 Involvement is a two-way phenomenon. While students of great power/small power relationships have traditionally focused on the former's impact on the affairs of the "penetrated" smaller country, there is presently a growing awareness of the reciprocal influence relationships that, in fact, arise. ^{27/} Accordingly, however unequal the relationship between the penetrating and penetrated countries may be, the fact of the great power's presence requires it to act on behalf of this presence on a more or less continuous basis. The demand to safeguard established interests necessarily implies certain constraints on great power policy flexibility, which otherwise might be available. Indeed, it has become increasingly apparent that great powers find it extremely difficult to divest themselves of "sunk costs," however desirable this might be on the merits of the situation at hand. The fear of the unknown "ripple effect" of reducing one's involvement in an area has been demonstrated again by the recent U.S. quandry over whether to meet the Ethiopian military junta's request for ammunition resupplies to fight the

^{27/} A "penetrated political system" has been defined as one in which "nonmembers of a national society participate directly and authoritatively, through actions jointly with the society's members, in either the allocation of its values or the mobilization of support on behalf of its goals." James N. Rosenau, The Scientific Study of Foreign Policy, New York, The Free Press, 1971, pp. 127-128.

Eritrean rebellion. On the one hand, it has been widely understood that implicit in the provision of U.S. military assistance abroad was the threat of its cessation. Consequently, arms aid programs would give the U.S. a certain amount of discretionary leverage over the recipients. On that basis, the Ethiopian request provided the U.S. with a clear-cut opportunity to demonstrate its displeasure with the country's internal course of events following the Emperor's forced abdication. Instead, Administration officials justified the eventual decision of resupply on the grounds that a failure to respond would harm the confidence of other countries that relied on U.S. arms supplies. In short, the U.S. had become a captive of its own long-standing involvement in Ethiopia.

4.41 The most serious constraint that flows from a great power presence is the risk of being drawn into active support of one of the belligerents in a local conflict. In this regard, it is somewhat paradoxical that the major countries in the world rarely perceive their maintenance of local intervention capabilities as the necessary consequence of policy-constraining national involvement abroad. Instead, military amphibious or airlift capabilities are generally understood to enhance flexibility of overall national policy.

Involvement-Commitment Link

4.42 Embroilment in local conflict situations may occur in at least four scenarios:

- a. A great power may deem it necessary to intervene militarily to protect certain

discrete interests, including such actions as the evacuation of citizens, the protection of property, or, as has been intimated recently, to safeguard uninterrupted access to critically needed mineral or energy supplies.

- b. A smaller power may use the vulnerability of a great power's stake within its national boundaries to "blackmail" the latter into supporting its position in a local conflict.
- c. Long-standing great power involvement may create "commitments," i.e., both sides (and possibly third parties) expect the larger power to provide military assistance to a threatened country.
- d. The linkage between involvement and commitment is likely to come into play particularly when the other party in a local conflict is receiving the support of an adversary great power. Naturally, this scenario may, itself, have come about from any of the three previously listed conditions, while its occurrence is likely to be a function, among others, of the degree of local, regional, or global competition perceived between the two respective great powers.

4.43 Recent history contains numerous instances that support the reality of these four scenarios. It also suggests that

the road from mutual great power involvement (through local conflict via mutual great power commitments and, finally, to great power confrontation) is the most dangerous implication of the intersection of interests and activities on the part of expanding great powers.

SUMMARY

4.44 Unlike assertions to the contrary, there is little historical evidence that supports the notion that mutual great power involvement may provide stability and controllability to otherwise volatile local conflict situations. Furthermore, little or no systematic research has been done so far to possibly spell out the conditions where such an effect might indeed be attainable. Instead, Robert E. Hunter's observation on the role of the respective U.S. and Soviet Middle East involvements in the 1967 Arab-Israeli war draws quite the opposite conclusion:

...for the superpowers, the Six-Day War called into question a basic premise about the possible development of the Arab-Israeli conflict. Previously, it was assumed that the presence of the superpowers in the area would enable them to impose some restraint upon the states of the Middle East closely dependent upon them for military or economic aid. In the event the crisis and war progressed too rapidly for the efforts of the great powers...either to prevent war or to stop it....Indeed, the presence of the great powers in the area may actually have made war there more likely. 28/
(Emphasis added.)

28/ Robert E. Hunter, "The Soviet Dilemma in the Middle East, Part I: Problems of Commitment," Adelphi Papers, No. 59, London, September 1969, p. 23.

PRESEARCH INCORPORATED

It is hoped that this study will elucidate some of the criteria and conditions conducive to a "stabilizing" role of mutual great power involvement in a third area of the world. In the absence of such insights, the expanding involvement --irrespective of its character--of one country into an area hitherto viewed as the traditional economic or political preserve of another single dominant power will tend to be perceived as a competitive thrust, precursory to larger scale penetration and eventual displacement of the originally dominant power.

V. OPERATIONALIZATION OF CONCEPTS

GENERAL

5.1 This section discusses the translation of the concept of manifest interest into a set of discrete operational elements that can be subjected to precise measurement.

EXTERNAL INVOLVEMENT AS A MEASURE OF INTEREST

5.2 It has been observed earlier that the governments and private citizens of the world's major countries engage in similar activities while expanding and protecting their nations' respective shares of international assets. History shows that even so-called "revolutionary powers" that initially reject legitimate modes of international interaction are eventually compelled to accommodate themselves, if they are to survive in the prevailing system of international relations. ^{1/} Russia's new Bolshevik regime realized very quickly the elusiveness of the announced goal of its first Commissar for Foreign Relations, Leon Trotsky, that "all there is to do is to publish the secret treaties [concluded between the Allied Powers in World War I]. Then I will close

^{1/} Henry Kissinger used the term "revolutionary power" for a state that "considers the international order or the manner of legitimizing it oppressive." Henry A. Kissinger, A World Restored, New York, Grosset and Dunlap, 1964, p. 2.

shop." ^{2/} Similarly, formal and traditional great power diplomacy and concerns, instead of unrestrained calls for worldwide revolutions, increasingly characterize the international conduct of the People's Republic of China.

5.3 While individual manifestations of international involvement are quite similar among the major powers, their relative emphasis or importance to the individual countries may be expected to vary. Commercial concerns thus seem to dominate the world role of such resource-poor powers as Japan and Great Britain. French policymakers, on the other hand, have emphasized strongly the pursuit of international "prestige" as a valuable asset for its own sake. The spread of French culture and language--the "mission civilatrice"-- is viewed as a foreign policy activity of the utmost importance. One student of French foreign policy has remarked:

Any attempt to understand French foreign policy must take into account the strong proselytising compulsion that demands from the educated Frenchman that he acquaint the barbarians with the achievements of his country's thought and culture. ^{3/}

The U.S., in turn, has frequently been criticized for what some claim to be a predominance of military considerations in

^{2/} Cited in Adam B. Ulam, Expansion and Coexistence--The History of Soviet Foreign Policy 1917-1967, New York, Praeger, 1968, p. 54.

^{3/} Herbert Tint, French Foreign Policy Since the Second World War, New York, St. Martin's Press, 1972, p. 165.

foreign policy at the expense of the more subtle means of international diplomacy.

5.4 Soviet foreign policy, by contrast, has often been characterized by its supposed highly developed political content. It is thought to systematically pursue international objectives through a well-integrated, mutually supportive combination of diplomatic, military, and economic tools of statecraft.

5.5 An exploration of empirical data on the great powers' manifest activities and interests abroad ought to clarify the degree of their similarity, as well as possible national differences in relative emphasis, or "style." The discovery of individual great power interest "profiles" ought to refine the analyst's understanding not only of the major countries' international concerns, but also of the particular mix of foreign policy instruments that the individual powers apparently deem most useful. Moreover, derivation of specific interest profiles should be indicative of the kinds of international leverages, or influence techniques, that may be available to the great powers in their relationships with different countries.

VARIABLE SELECTION

5.6 The present selection of discrete manifestations of multiple power worldwide interests has been guided principally by the experience gained in an earlier study, entitled

Identification and Measurement of U.S. Interests Abroad. ^{4/}

As the predecessor to the current research effort, this study demonstrated the usefulness of applying quantitative data and research techniques to a systematic exploration of the character and extent of U.S. interests worldwide. In particular, the research involved the collection of more than 10 years of data values across 30 indicators believed to be a representative cross-section of U.S. private and public, commercial, political, military, and sociocultural interests in over 100 countries.

5.7 The usefulness of the data collected in the preceding study and the desirability of reliable comparative analysis indicate that a maximum effort should be made to assure the consistency of the indicators across the 6 major countries studied. This decision was made in full understanding of the uncertainties likely to be involved in tracking down and acquiring foreign source data material. The difficulties and frustrations involved in the collation of large data collections are familiar to anyone who has ever been involved in aggregate data analyses. Problems are compounded as soon as the investigator finds that necessary data are not available in the U.S., but have to be pursued through the cooperating foreign government agencies. Some of the difficulties that may be expected--and were indeed encountered--include the following: variations in the quality and reliability of national statistical reporting procedures; national differences in terminologies, concepts, and reporting criteria

^{4/} Jan S. Breemer and Peter H. Finn, Identification and Measurement of U.S. Interests Abroad, Falls Church, Va., Westinghouse Electric Corp., Contract MDA-903-74-C-0223, 1974.

PRESEARCH INCORPORATED

employed; and differences in national classification schemes, i.e., some countries classify certain types of information that others do not. One dominating issue, of course, is the varying degree of responsiveness on the part of different foreign government agencies to requests for information regarding their international activities.

5.8 An important data-related issue is that some of the categories of national involvement abroad that were used in the study mentioned above were not necessarily shared by the five powers presently under study. An obvious case is the absence of overseas direct private investment in Soviet international involvement behavior. Also, the Soviet Union does not have an identifiable counterpart to the sociocultural stake that, it is argued, has sprung up in the U.S. with the influx of large numbers of immigrants over the years. In cases like these, where a country simply does not participate in certain international activities, the study team was compelled to exclude the pertinent variables, so that any comparative policy conclusions must take careful account of such deviations.

5.9 Finally, despite the resolve that the data collected should be compatible across the major powers analyzed, the need was realized for occasionally using substitute variables.

CLASSIFICATION OF MANIFEST INTERESTS

5.10 Most foreign policy analysts discuss and analyze international politics in terms of its respective political, military, economic, and, to a lesser extent, sociocultural

PRESEARCH INCORPORATED

manifestations. ^{5/} Although arbitrary, this compartmentalization was deemed useful in guiding the collection of the various interest data. Analysis of the data itself was expected to determine their de facto discreteness.

5.11 It must be stressed that the selection of variables to be presented next does not constitute a random sample of a possible universe of great power interests; instead, the variables were chosen in the belief that they were reasonably representative of the total distribution of great power values throughout the international system.

ECONOMIC INTERESTS

5.12 The notion that countries have identifiable foreign economic interests is probably the least controversial of the four types of interests postulated. To many countries, e.g., Japan and Great Britain, ever-expanding foreign exports are crucial to national growth and domestic prosperity. Even in the U.S. and Soviet Union, countries that benefit from enormous domestic markets, promotion of international trade takes up a large share of the national policymaker's attention and effort.

5.13 Foreign imports also constitute a highly significant component of a nation's international economic stake. Despite the adverse effect of imports on the national balance of

^{5/} For instance, a study of the Arab-Israeli conflict that appeared a few years ago analyzed U.S.-Soviet involvement with respect to their respective military, political, economic, and cultural policies. J. C. Hurewitz, ed., Soviet-American Rivalry in the Middle East, New York, Praeger, 1969.

PRESEARCH INCORPORATED

payments, nations share an economic stake in the countries from which their imports originate for at least two reasons. First, the particular commodities received may fall into that rather obscure category labeled "critical strategic materials." Secondly, it must be assumed that nations (in most cases, their private business communities) derive their imports at the lowest cost possible. ^{6/} Consequently, the loss of imports from a particular country can only be regained by imports from an alternative source at a higher price.

5.14 Sheer volume of trade is not the sole criterion for a bilateral trade relationship. Nations, like commercial enterprises, constantly evaluate commercial performance (like their political and military performance) in relation to other countries. National world trade statistics are thus normally expressed in dollars (francs, deutsche marks, etc.) as well as proportional market shares. Relative market shares are important indicators not only of the extent of a country's commercial penetration and, by implication, its commercial and, possibly, political leverage, but also of the competitiveness of its international trade. Since, with few exceptions, large volumes of trade do not appear to be accompanied by high degrees of commercial penetration, it is important that a great power's international commercial stake be described and analyzed on both levels.

DIRECT PRIVATE INVESTMENT

5.15 Overseas private investment is a third identifiable aspect of a nation's economic stake abroad. Despite contemporary

^{6/} It is conceivable that, for political reasons, importing nations are willing to pay higher than market price for imported goods from certain countries.

PRESEARCH INCORPORATED

concern with the "extranational" character and power of the large multinational corporations and the questioned ability of both home and host country to maintain effective authority over the corporations' actions, it is generally held that overseas investments constitute an important national asset, whose security may, at times, demand the protection by national power and diplomacy.

5.16 Private investments in a foreign country's economy are perceived to be important on at least two grounds. First, at least part of the income stream associated with an overseas economic activity is returned to the home country and is added to the national balance of payments. Secondly, private investment in certain types of foreign industry (principally extractive) may secure privileged national access to critical foreign resources. A case in point is the "buffer effect" that the oil companies had in helping to immunize the importing countries from the full effect of OPEC's petroleum embargo in early 1974. Thus, despite the Arab boycott, the Anglo-Dutch Shell Company's control over the international distribution process through its tanker fleet helped secure adequate petroleum imports for the Netherlands.

INTERNATIONAL MOVEMENT OF NATIONALS

5.17 Associated with international trade and overseas investments are normally large numbers of private citizens engaged in the daily conduct and advancement of their home country's commercial interests. Overseas business communities constitute only a fraction of the nationals that may be found outside the national boundaries at any one time. Tourists, students, and, particularly in the Western European countries,

PRESEARCH INCORPORATED

unskilled foreign laborers (the so-called "guestworkers") add up to an important interest for the governments of the respective home countries. Indeed, as demonstrated during the "Mayaguez" incident, few uses of national power carry as great a consensus as the protection of the lives of citizens abroad.

5.18 To recapitulate, the following activities are considered important manifestations of a nation's economic or, perhaps more precisely, commercial stake abroad:

- Imports
- Exports
- Private investments
- Tourist flows
- Export market shares
- Import market shares
- Overseas residents.

OPERATIONALIZATION OF ECONOMIC INTERESTS

5.19 The following measures were used to operationalize the selected manifestations of a major international actor's economic interest in foreign countries:

- Imports: the annual bilateral dollar value of a major actor's commodity imports
- Exports: the annual bilateral dollar value of a major actor's commodity exports

PRESEARCH INCORPORATED

- Private Investments: the annual monetary book value of a major actor's direct private investments abroad
- Tourist Flows: the annual number of a major actor's nationals traveling abroad
- Export Market Shares: the annual bilateral value of a major actor's commodity exports, divided by the recipient country's worldwide imports
- Import Market Shares: the annual bilateral value of a major actor's commodity imports divided by the sending country's worldwide exports.

POLITICAL INTERESTS

5.20 The notion that great powers have discrete political stakes in foreign countries is more ambiguous than it may appear. As has been observed earlier, many analysts of international politics find it convenient to discuss and evaluate international events in terms of their respective economic, political, and military relevance. At the same time, most observers would find it extremely difficult to identify and discuss a strictly political interest without linking it-- implicitly or explicitly--to overriding, or least related, economic, strategic, or security concerns.

5.21 The difficulty of separating political from nonpolitical interests lies in the lack of specificity of the term "international politics." Most theorists of international relations agree that international politics defines the processes whereby

nation-states (or, more precisely, their respective governing elites) attempt to influence each other's behavior. Thus, Hans Morgenthau states: "International politics, like all politics, is a struggle for power," the possession of which "gives control over certain actions...through the influence which [the power holder exerts over others' minds.]" ^{7/}

5.22 Agreeing with Morgenthau, James N. Rosenau writes:

...international politics is similar to local or national politics through the fact that, in each case, the actors seek to modify behavior in their remote environments. Whether the actors are engaged in local, national, or international politics, their task is to mobilize support--to engage in control relationships--which will facilitate the preservation of those aspects of the environment that are desirable and ^{8/} the alteration of those that are not.

5.23 The critical concept in the term "international politics" is, therefore, the ability to influence or control the international environment, i.e., other states' behavior, to the benefit of one's own national society. It is from this definition, however, that the difficulty of distinguishing between political and nonpolitical interests emerges. Namely, the relevant environment to be controlled through political action presumably

^{7/} Hans J. Morgenthau, Politics Among Nations: The Struggle for Power and Peace, 4th ed., New York, Alfred A. Knopf, 1967, pp. 25,27.

^{8/} James N. Rosenau, The Scientific Study of Foreign Policy, New York, The Free Press, 1971, pp. 210-11.

pertains to the constant competitive need to expand and safeguard one's share of international valuables. This signifies that, unless nation-states engage in politics for its own sake (which, in fact, the "power theorists" tend to imply) international politics is a necessary "by-product" of the existence of nonpolitical stakes, i.e., economic or security stakes.

5.24 Professor Holsti thus logically observed that "the greater the involvement, dependence, or interdependence, the greater the necessity to wield influence over other nations." ^{9/} (Emphasis added.) A case could be made that unlike international commercial interaction, for example, the activity called international politics cannot exist independently. Marshall R. Singer's citation of Professor Alex Weilemann is highly relevant:

...there are very few things that are political in and of themselves. If the act of voting is essentially political, it is because the entire situation surrounding it makes it so; but the act of dropping a piece of paper into a box or of pulling a lever in and by itself is not. If we want to define "political" in the same way in which we define "economic" or "educational"... or "military," etc., we are likely to limit ourselves too much. As a Belgian theorist...said, the political system cannot (successfully) stand on its own, but spills over into all kinds

^{9/} K. J. Holsti, International Politics--A Framework for Analysis, 2nd ed., Englewood Cliffs, New Jersey, Prentice-Hall, Inc., 1972, p. 157.

of other systems, and in reverse, there is not an individual or group or activity that is not potentially a member of the political system. ^{10/}

5.25 Professor Weilemann's argument logically suggests that it may be more useful to consider a great power's political stake abroad as the consequence of other stakes (e.g., commercial) rather than as a separate category. It also intimates that an explicit accounting of a nation's foreign commercial, security, and other nonpolitical interests should necessarily disclose its political stakes, or what its political stakes ought to be.

5.26 Logic aside, however, great powers may, and frequently do, act on behalf of interests that are essentially political and that have no discernible relationship to other interests, which are often labeled "true" interests. Prestige or credibility are the terms frequently used to explain, justify, or criticize policy moves with no readily apparent relationship to other, identifiable interests. The debate over the U.S. interest in South Vietnam clearly illustrates the dilemma. Those who argued that the U.S. had no interests in South Vietnam were basing their assessment on the absence of non-political stakes, e.g., investments, important raw materials, and U.S. security. Supporters of U.S. policy generally agreed but pointed out the overriding importance of the U.S. political stake, i.e., the involvement of national credibility and prestige.

^{10/} Cited in Marshall R. Singer, Weak States in a World of Powers: The Dynamics of International Relationships, New York, The Free Press, 1972, p. 310.

5.27 The de facto relevance of discrete political stakes has been elucidated by Charles Wolf, Jr.:

Clearly, individual countries can acquire a symbolic political value which exceeds their actual economic and military importance. There is, in fact, probably no better indicator of the symbolic political importance that countries acquire than the extent of a prior United States commitment, whether formal or tacit, to assure the country's viability and independence from communist control. United States commitments may be signified by formal guarantee... [or] more informally by large military aid programs or by substantial amounts of nonmilitary aid...In such cases, a country's importance...will exceed that which can be measured simply by looking at the economic and military components of value. ^{11/}

5.28 Observation of actual nation-state behavior confirms the desirability of taking explicit account of the great powers' international political assets. Subsequent analysis ought to clarify the extent to which these are linked to nonpolitical interests.

5.29 Great powers engage in a number of international activities that are considered primarily political in nature. They include the conclusion of formal treaties, the exchange of diplomatic representatives, the provision of economic assistance, and the maintenance of cultural exchange programs.

^{11/} Charles Wolf, Jr., United States Policy and the Third World--Problems and Analysis, Boston, Little, Brown and Co., 1967, p. 19.

PRESEARCH INCORPORATED

TREATIES IN FORCE

5.30 The conclusion of bilateral or multilateral treaties has been the traditional political means among sovereign nation-states to institutionalize international relationships. Frequently, treaties merely serve to codify already existing informal interaction patterns that have reached such importance that mutual obligations and expectations need to be explicitly delineated. The raison d'être for formal treaties is, therefore, the mutually beneficial protection of the signatories' interests. In other words, a treaty systematizes an informal mutual influence (political) relationship that is the necessary result of expanding interaction among nation-states.

5.31 Originally a "means," a treaty relationship (a military alliance in particular) may become an "end" in itself. Circumstances may change drastically, but policy momentum, bureaucratic interests, or simply habit may make the preservation of a formal commitment itself a policy objective. As a result, it may, at times, be difficult to determine whether the political importance of a treaty relationship should be sought in some broader value than that which presumably gave rise to the treaty in the first place or in the existence of the treaty itself. In other words, is a treaty in force merely a political indicator of some other, nonpolitical interest, or is it to be viewed as a political stake itself?

DIPLOMATIC PRESENCE

5.32 The exchange of diplomatic representatives constitutes a second political means by which nation-states attempt to influence each other's policies and actions and thereby to

secure and advance their interests vis-a-vis the respective host countries. The functions and size of a country's diplomatic representation will vary, depending on the dominant character and the magnitude of its interests in a particular host country. Thus, the protection of nationals residing or traveling abroad may be the embassy's principal task in some countries, while among the developing foreign aid recipients, a symbolic presence may be the representation's critical role. Obtaining information, providing advise to national decision-makers at home, or simply maintaining a communication channel between national capitals is likely to be the primary task of diplomatic representatives assigned to "unfriendly" nations.

5.33 In general, the larger and the more diversified a country's interests abroad, the larger its diplomatic staff will be. Marshall R. Singer has noted that the size of the host country will further inflate the number of diplomatic representatives abroad: "...the size (both physical and in terms of population) of the country, and the political saliency of that country at a given time would be major factors in determining the number of diplomats sent [by the major powers]." ^{12/} Singer's observation suggests that measures of the size of diplomatic representations may need to be adjusted against the size of the host countries, so that a more accurate estimate of a country's "political saliency" alone may be derived.

5.34 Like formal treaties, diplomatic representations exist principally to further prior interests; nation-states simply

^{12/} Marshall R. Singer, op.cit., pp. 335-36.

PRESEARCH INCORPORATED

do not establish embassies in countries with whom they have little or no interaction. Unlike treaties, however, the presence of diplomats overseas represents a clear, distinct stake to the sending country. As with all nationals traveling abroad, a country has the clear obligation to protect its foreign representatives from injury. This obligation is magnified by the very function of diplomats as de facto extensions of their home countries. It is also for that reason that diplomatic personnel tend to be more exposed to risks than are private citizens. A deliberate failure by a host country to assure the safety of foreign diplomats is, in effect, a hostile act to the sending country involved and, as such, may precipitate a diplomatic and, possibly, a military crisis.

DEVELOPMENT ASSISTANCE

5.35 The provision of foreign economic and technical assistance is widely recognized as predominantly a politically motivated activity. Promotion of foreign trade probably occupies a close second place, whereas purely humanitarian reasons tend to be the exception rather than the rule.

5.36 Although the political payoff to a donor country of economic aid is less than clear, most major suppliers are hesitant to eliminate or substantially reduce their programs for fear of uncertain repercussions or that such action might put their competitors at an advantage. Thus, even where a donor country does not reap any evident political or economic rewards, the provision of assistance itself tends to assume, more often than not, a uniquely political importance. Moreover, it should be noted that the political impact of economic

aid extends beyond the mere infusion of dollars, francs, or rubles or the natural desire on the part of the donor country to see its aid program succeed. Marshall R. Singer has summed up some of the concomitants of foreign aid that reinforce its political essence:

When economic aid is extended to a country, there is likely to be an influx of foreign technicians to administer the aid and to offer development assistance. The more of these foreign nationals there are in a country, and the longer they are there, presumably the more they will be able to inculcate their value system in the host country....The more sophisticated American government adviser and his Russian, British, and French equivalents are only too aware that it is not just development they are trying to encourage, but development along the lines proven successful in their own countries. ^{13/}

5.37 Because of the political strings that most recipients and donors expect to be attached to large-scale economic aid, most recipients attempt to rely on multiple sources of aid or on multilateral agencies. Although there has been a trend on the part of donor countries to distribute a larger share of their aid through multilateral agencies, most prefer to deal bilaterally. For example, in 1972 only 13.49% of all Organization for Economic Co-operation and Development (OECD) assistance was disbursed through the multilateral International Development Administration, the U.N., and the European Development Fund. ^{14/}

^{13/} Marshall R. Singer, op. cit., pp. 335-36.

^{14/} Organization for Economic Co-operation and Development, Development Co-operation, 1973 Review, Paris, 1973.

5.38 No country has expressed its political incentive for bilateral assistance more insistently than France. According to Prime Minister Pompidou in 1964:

It remains true that multilateral aid, in the way it is handled in the big international organisations, ends up by reinforcing the English language. And I repeat, we, as Frenchmen, feel a kind of need to maintain the French language. This a fundamental reason for maintaining bilateral aid. 15/

5.39 Economic assistance, therefore, must be considered a discrete political stake for at least two reasons. First, a donor country provides aid to certain countries because it believes it to be an important means for influencing the recipient governments on behalf of its (the donor's) local stakes. Secondly, recipient countries tend to become identified with their respective donors as the result of long-term aid programs; recipients expect to receive aid, while the donor tends to develop a prestige stake in the success of its aid program.

CULTURAL AND EDUCATIONAL EXCHANGES

5.40 Government-sponsored cultural and educational exchange programs are viewed as a relatively inexpensive but important means of political communication. Their political motivation is evident in the fact that most major countries' exchange programs are funded and administered by the foreign ministries.

15/ Address before the National Assembly on June 10, 1964. Cited in Herbert Tint, French Foreign Policy Since the Second World War, New York, St. Martin's Press, 1972, p. 185.

PRESEARCH INCORPORATED

5.41 Foreign cultural and educational programs encompass a variety of activities. They include sending performing artists; exchanging nuclear scientists, educational personnel, and trade union delegations; establishing libraries; and exchanging university students.

5.42 Some foreign cultural activities reflect peculiarly national pastimes. Thus, the Soviet Union exports ballet troupes, the U.S. Jazz musicians, China ping pong teams, and Japan flower arrangers.

5.43 While all of the above activities presumably contribute to the international image of the sponsoring countries, there is little question that educational programs are by far the most important component in most nations' cultural efforts. Many observers agree with Marshall R. Singer's statement that "it seems quite clear that the vast majority of students who study abroad come away more positively inclined toward the country than they were before they went." ^{16/} Theodore Caplow and Kurt Finsterbusch went even further in their observation on "the massive transfusion of the host country's ideas and values into the sending country when the students return home." ^{17/}

5.44 While all six of the major countries studied engage in foreign educational efforts, the size of their respective programs varies as does, apparently, the relative priority

^{16/} Marshall R. Singer, op. cit., p. 151.

^{17/} Theodore Caplow and Kurt Finsterbusch, "France and Other Countries: A Study of International Interaction," Journal of Conflict Resolution, Vol. 12, No. 1, March 1968, p. 4.

placed on them. Japan, for instance, has a relatively small educational training program, in part because of language difficulties. To a lesser extent, the Soviet Union is faced with a similar problem when it attempts to attract students from the former colonies who frequently speak French or English and are therefore inclined to pursue their studies in France or Britain.

5.45 In general, the geographic distribution of the major powers' cultural proselytizing efforts reflects either former colonial links or, in the case of the U.S. and the Soviet Union, a product of their post-World War II ideological competition. French and British educational programs are clearly concentrated in Africa, U.S. primarily in Latin America, Japanese in East Asia, Soviet in the Middle East and North Africa, while West Germany has tended to diversify its efforts without an evident geographic preference.

5.46 As pointed out earlier, of all the major powers studied, France has probably engaged in the most intensive cultural expansion effort. Guided by a general assumption of the excellence of its language and culture, France has made a consistent effort to create "la Francophonie"--a community of nations tied together by a shared (French) language and cultural and educational values. The general popularity within France of this policy has been due, according to Dorothy Pickles, "more to the general belief that it contributed to France's prestige in the world than to any specific political or economic advantages that she might derive from it." ^{18/}

^{18/} Dorothy Pickles, The Government and Politics of France, Vol. 2, Politics, London, Methuen and Co., 1973, p. 311.

5.47 Although the pursuit of international prestige for its own sake plays a unique role in the decisions of French policy-makers, cultural policy, and foreign education in particular, is believed to generate important political and other benefits for France. ^{19/} Thus, while acknowledging the possibility of reciprocal cultural enrichment, the important "Jeanneney Report" ^{20/} of 1963 on French cultural efforts abroad also saw solid value in the outlook for diplomatic and military support from grateful recipients of French largesse. From the viewpoint of national defense, the report envisioned strengthened positions for France both within the Western alliance and vis-a-vis potential enemies, through French control of intercontinental tracking stations and communication and transport facilities.

5.48 The general view that the French education of students from former Black African colonies has important political benefits has been explained by Keith Irvine:

Regardless of their personal experience in France...or their political inclinations as students, most returnees assume a moderate political hue when they get home. They are

^{19/} According to Herbert Tint: "the teaching of the French language abroad...is an obvious first step to other forms of penetration." Herbert Tint, op. cit., p. 167.

^{20/} Rapport de la Commission d'Etude de la Politique de Coopération Avec les Pays en Voie de Développement (Jeanneney Report), Paris, La Documentation Française. Cited in Keith Irvine, "Francozone Africa," Current History, Vol. 56: 333, May 1969.

PRESEARCH INCORPORATED

usually immediately absorbed into the national establishment, where the prestige of their residence in France automatically ensures their position. They then have a built-in bias to support the status quo. Tens of thousands of such former residents in France over the past decade constitute a solid bloc of influential individuals whose personal stake in French prestige is an asset for France in practically every context. 21/

5.49 The other great powers have basically similar expectations with regard to the political rewards of overseas educational programs. The U.S., for instance, promotes its international exchange programs on the grounds that foreigners will return home with a better appreciation of "American ideals" and "democratic institutions"--values, it is hoped, that will eventually germinate in their native countries. The underlying assumption is, of course, that a world of democratic nations will necessarily be more stable and peaceful and, hence, contribute to the welfare and security of the U.S.

5.50 Soviet leaders have made it similarly clear that they expect their foreign educational programs to have important future political payoffs. Addressing the first graduating class of the Patrice Lumumba Friendship University in 1965, Premier Kosygin declared:

We are confident that the University graduates as well as the two thousand foreign specialists graduating this year from other Soviet educational establishments will show themselves

21/ Ibid., p. 3.

PRESEARCH INCORPORATED

and their countries to be not only excellent engineers, doctors, teachers, economists, but also frontrankers in the struggle for the national revival of their countries, for the social progress of their peoples....We would like the University graduates to remain our friends, to become the bearers of an inviolable friendship between their peoples and the peoples of the first country of socialism. 22/

5.51 Evidently, national cultural, technical, and educational exchange programs tend to be valued as singularly politically motivated activities. It is to be expected, therefore, that the geographic locus of a program is a pertinent indicator of the importance of the political or other stake that the sponsoring great power perceives in the target country or region.

5.52 To recapitulate, the following activities were selected as valid indicators of a major international actor's political interest abroad:

- Treaty relationships
- Diplomatic representations
- Overseas development programs
- Cultural and educational exchange programs.

22/ U.S. Department of State, Research Memorandum, RSB-10, Washington, D.C., 1967, pp. 34-35.

OPERATIONALIZATION OF POLITICAL INTERESTS

5.53 The following operational measures were employed to systematically investigate the strength of a major actor's manifest political interest abroad:

- Treaty Relationships: the aggregate number of bilateral and multilateral diplomatic treaties concluded since August 1945 and in force in the year of interest.
- Diplomatic Representation: the total number of diplomatic personnel under the jurisdiction of the local ambassador.
- Overseas Development Programs: the annual dollar value of development loans and grants; the annual number of development advisory personnel (e.g., AID) in the country; the annual number of development volunteers (e.g., Peace Corps) in the country.
- Cultural and Educational Exchange Programs: the annual number of foreign academic students and technical trainees funded and sponsored by the major international actors.

MILITARY INTERESTS

5.54 Great powers display their military or security interests in foreign areas in a number of ways, including the conclusion of mutual defense alliances, the deployment of military forces,

and the provision of military assistance. The notion of a distinct military stake shares some of the same conceptual difficulties as the idea of a discrete political interest. The military component of a major power's international activities is generally a means to secure those international assets it deems valuable, whether they are security or economic gain. Therefore, overseas military involvement has no role in and of itself. ^{23/}

5.55 At the same time, it has been widely recognized that such acts as the overseas stationing of military forces or the extension of a security guarantee tend to be transformed from a means to an object of foreign policy. Military involvement frequently becomes an independent national stake abroad. Ralph N. Clough spoke of this process when he defined "created interests" as "those that the United States (or, presumably, any other country) itself creates in a given country by taking actions (especially by making defense commitments or by actually deploying its armed forces) that create an expectation that the United States would use armed force there in order to protect other types of interests." "Once created," the author added, "such interests are hard to extinguish. Furthermore, they tend to breed other interests." ^{24/}

MILITARY DEPLOYMENTS

5.56 The presence of military forces on foreign soil represents more than a tangible manifestation of the deploying

^{23/} An exception would be a "militaristic" nation that engages in military expansion and display for their own sake.

^{24/} Ralph N. Clough, East Asia and U.S. Security, Washington, D.C., The Brookings Institution, 1975, p. 30.

PRESEARCH INCORPORATED

power's interest in the security of the host country on at least two counts. First, it circumscribes a specific, definable national stake itself. Secondly, many observers believe that the overseas deployment of national military forces tends to yield certain benefits, which, although difficult to pinpoint, are nevertheless real.

5.57 More so than private nationals or even members of the diplomatic corps, military personnel represent a de facto extension of the national integrity of the deploying power. The "trip wire" idea vividly symbolizes the expectation that an attack against foreign military forces will be treated as an attack on the territory of the deploying power.

5.58 Foreign military presence, overseas basing, staging areas, etc., initially conceived in support of a specific national objective, tend to frequently assume a rationale of their own once established. Roles and missions may change, but the facilities tend to remain and to become important foreign policy issues in their own right. Although overseas defense positions may outlive their original purpose, their retention is frequently urged on the basis of the uncertain, but the most likely damaging, effect their elimination is feared to have on other interests. Some opponents of a U.S. troop reduction in Europe have warned, for instance, of a resurgent military West Germany or have implied certain economic benefits that the U.S. has gained from its security guarantee. In a broad sense, therefore, many observers share the largely intuitive belief that a positive relationship somehow exists between the overseas projection of military strength and national advantage.

5.59 The idea that the projection of "external authority" should be "treated as an intrinsic component of the national interest and not merely...as a derivative of national security or of the national interest in freedom of trade and navigation," ^{25/} has been advanced most clearly by Grant Hugo in the following passage. He has been cited at length since he enumerates a number of propositions that are extremely important to the debate over the future U.S. role in the world:

...on what rational grounds does Britain require to exercise authority beyond her territorial limits and to what extent?...Historically there seem to have been three main incentives to its exercise...(to provide revenue), to facilitate the conduct of military operations; and to protect the private interests of British subjects....The political motive (for the third incentive) is expressed in the ancient legal maxim: protection draws allegiance and allegiance draws protection....Nowadays a transfer of allegiance by an overseas community can seldom threaten the security of the nation-state in Britain itself, but it can still entail the loss of important political and commercial advantages. As long as British expatriates retain their allegiance, they usually employ their local influence to the benefit of Britain....But no sentiment is politically so efficacious as patriotism and this seldom survives a transfer of allegiance....This link between allegiance and protection applies to communities as well as to individuals. The loyalty to Britain of the English-speaking countries of the Commonwealth has been directly proportional to their reliance on British protection. As this

^{25/} Grant Hugo, Britain in Tomorrow's World: Principles of Foreign Policy, New York, Columbia University Press, 1969.

has declined, so has the proportionate importance of British trade and investment in these countries and so, sentiment notwithstanding, has their readiness to afford political or military assistance Weighing the cost of external authority against its advantages has never been easy, because both sides of the equation are affected by multipliers of a somewhat indeterminate character.... Any attempt to assess the cost-effectiveness of maintaining a particular element of Britain's external authority must take account of the wider repercussions that any decision will entail. To hold a base may involve the conquest of its hinterland; to abandon it may invite a threat to another. This is why external authority has been treated as an intrinsic component of the national interest and not merely... as a derivative of national security or of the national interest in freedom of trade and navigation. These considerations may have prompted the acquisition of external authority and justified its maintenance. They can legitimately be invoked in considering its practical application or modification. But nine centuries have not merely encrusted the idea of external authority with sentiment and tradition: they have transformed it from a mere expedient to an objective in its own right.... [External] authority, as a component of the national interest, is more comprehensive, and historically, perhaps more potent and enduring, than those considerations arising from the balance of payments with which it is so closely associated. ^{26/} (Emphasis added.)

^{26/} Ibid., pp. 82-87

MILITARY TREATIES

5.60 Robert E. Osgood has defined a military alliance as "a formal agreement binding states to cooperate in using their military resources against a specific state or states and usually entailing an obligation on the part of one or more of the signatories to use force, or to consider...the use of force, in specified circumstances." ^{27/}

5.61 In theory, the signatories to a treaty of alliance carry equal political weight and are equally responsible for each others's security. In practice, however, most contemporary military alliances embody a de facto, one-sided security guarantee on the part of the strongest to the weaker members of the alliance.

5.62 The extension of a formal security commitment is generally considered the most explicit demonstration of a great power's interest in the well-being and integrity of the protected state or states. The guaranteeing power effectively announces that the security and territorial integrity of its allies are virtually integral to its own and that, therefore, it has a strong incentive to treat a threat against them as if it were directed against the great power itself.

5.63 Formal military alliances are only one type of military treaty that can bind a country to the protection of another. Because of the generally vague phraseology that is used in

^{27/} Robert E. Osgood, "The Nature of Alliances," Johns Hopkins University, School for Advanced International Studies, Washington Center of Foreign Policy Research, The Future Role of Military Alliances, Washington, D.C., 1966, pp. 1-3.

PRESEARCH INCORPORATED

most treaties of alliance, additional military treaties are usually concluded to further specify, clarify, or expand on the original language. Typically, additional agreements pertain to base or overflight rights, status of forces, sharing of defense technology, etc. In fact, the more specific language of supplemental agreements may at times imply a greater commitment than was intended in the original treaty of alliance.

5.64 Because of the expressed willingness to use military means on behalf of another nation (and, by implication, to be exposed to military hostilities on behalf of the other nation) a military alliance and its corollary agreements are probably the most important formal international agreements made. Moreover, a military alliance is "exclusive," i.e., unlike commercial or cultural agreements, the recipient of a formal security guarantee cannot engage in an alliance with the party against whom the first obligation is directed. The guarantor nation has an exclusive security stake in the protected country.

SECURITY ASSISTANCE

5.65 Military alliances usually engender security assistance from the primary protecting power to the other, protected, member nations. The existence of an alliance is not a necessary prerequisite, however, for the provision of equipment, training or logistical support. A donor or recipient nation may prefer to avoid the dramatic international impact that the conclusion of a military alliance tends to have or the restriction of political flexibility that may result. Moreover, once entered into, a formal military pact frequently becomes a long-term, self-sustaining interest that, despite changing conditions, tends to generate a strong presumption against its abrogation.

PRESEARCH INCORPORATED

5.66 In theory at least, arms aid alone is a more expedient mechanism. It involves a more restricted contract, and it allows the supplier to insulate himself from conflicts where an alliance relationship might not. Security assistance per se may serve purposes other than enhancing the recipient's and, theoretically by extension, the donor nation's security. For instance, based on the belief that arms aid procures political influence, a great power may initiate an assistance program simply to preempt its provision by alternative, rival sources.

5.67 The extent to which the different great powers perceive their security assistance programs as political rather than uniquely security-oriented activities should be demonstrated by the degree of empirical linkage that exists between security assistance and other indicators of political stakes abroad. For data organization, it has been assumed that the provision of military aid is one aspect of a great power's military stake abroad.

ARMS SALES

5.68 It has been only very recently that the commercial sale of military equipment and services has begun to be treated as a major power activity with an identity of its own. Previously, military assistance and military sales tended to be viewed as a single reflection of the donor nation's interest in the recipient's security.

5.69 It has become increasingly difficult, however, to distinguish between security and commercial motivations in the foreign cash or credit sales of military hardware. Many

PRESEARCH INCORPORATED

critics of the contemporary boom in arms sales contend that the supplier countries are primarily concerned with improving their balance of payment or maintaining domestic employment levels.

5.70 The apparently multidimensional character of the commercial arms sales phenomenon is further complicated by the political importance that is attached to it. The sale of weapons to a particular country is frequently justified on the grounds of the political influence that is presumed to accrue. The French Government, for instance, justified its Mirage sale to Libya partly on the grounds that, since nothing prevented the Libyans from acquiring their arms elsewhere, it was preferable to establish French rather than Soviet influence. ^{28/} Similarly, U.S. Government spokesmen have repeatedly argued that the provision of U.S. equipment will provide the political leverage to inhibit potential military conflicts. Secretary of Defense Schlesinger testified in the summer of 1973:

Our ability to influence and constrain (other countries') activities, to preclude their going to hostilities or to temper their tendency to go toward hostilities, is enhanced if they have decided to buy military hardware from the U.S. and if there is a close association between U.S. military leaders and the officers of the countries concerned, as opposed to a condition in which there is a close association between, say, Soviet military officers and the leadership of the country concerned. ^{29/}

^{28/} See Dorothy Pickles, op. cit., pp. 324-25.

^{29/} U.S. Senate, Committee on Appropriations, Hearings, Foreign Assistance and Related Programs Appropriations, FY 1974, 93rd Congress, 1st Session, Washington, D.C., Government Printing Office, 1973, p. 1295.

PRESEARCH INCORPORATED

5.71 Summarizing, the following indicators of military involvement were selected to operationalize the idea of a major actor's overseas manifest interest:

- Military deployments
- Military treaty relationships
- Security assistance
- Military sales programs.

5.72 Operationalization of these four measures proceeded as follows:

- Military Deployments: the annual total number of uniformed personnel stationed abroad, either in an advisory-training role or performing a direct combat-related mission.
- Military Treaty Relationships: the aggregate number of bilateral and multilateral military treaties concluded since August 1945 and in force in the year of interest.
- Security Assistance: the annual delivered dollar value of military equipment and services provided as grant aid.
- Arms Sales: the annual delivered dollar value of military equipment and service provided on cash or credit terms.

VI. METHODOLOGY

6.1 This section describes the three principal methodological steps that were followed in the analysis. The first step was to examine the empirical interrelationships that exist among the various selected indicators of the major actors' external interests. Secondly, the dimensional compositions of the five major powers' manifest external interests were explored. The last step was to measure the relative importance of over 100 countries on each of the five major actors' external interest profiles.

CORRELATION ANALYSIS

6.2 Pearson product-moment correlation was used to investigate the degree of bivariate association among all the variables selected. Coefficients of correlation (r) were computed for each pair of variables, across all country cases in the source data matrix. The correlation coefficient is a numerical expression of the strength and direction (positive or negative) between two or more phenomena; in general, the higher the coefficient (which may range from -1.0 to +1.0) is, the stronger the relationship. ^{1/}

^{1/} The size of the sample (i.e., the number of cases) tested is critically important to the significance of the correlation coefficient; the larger the number of cases, the greater the probability that the association will not be due to chance.

6.3 Correlation coefficients have another important attribute: the square of the coefficient, or the coefficient of determination, gives the proportion of the total variance that can be predicted by knowledge of the relationship. A hypothetical coefficient of 0.80 between phenomena X and Y means that 64% $[(0.80)^2 \times 100]$ of the value of X for a particular case can be "predicted" from its value on Y. The product-moment correlation coefficient is therefore a measure of both the strength of relationship and of prediction.

6.4 The computation of bivariate correlation coefficients is only the intermediate step between the original source data and the construction of the final rotated factor matrices. At the same time, a correlation matrix contains much useful knowledge that may lead the analyst to test various hypotheses and theories on the relationship between pairs of variables. In particular, the coefficients may have highly bivariate associations between two discrete aspects of a major actor's external involvement that are evident from the multivariate relationships that are contained in the final rotated matrices. Since it is the property of factor analysis to seek out those clusters or groups of variables that display the greatest amount of intercorrelation, weaker, but possibly still significant, binary relationships between variables tend to be suppressed. In particular, the terminal factor solution may fail to depict time-series trends between pairs of variables, which, although weak statistically, may suggest future developments that deserve the attention of the policy planner.

FACTOR ANALYSIS

6.5 The computation of multivariate factor matrices was the second step toward the study's goal of systematically

defining the empirical composition of a major actor's manifest external interest profile. The principal characteristic of factor, or component, analysis is its ability to reduce a host of seemingly unrelated information to a limited number of common factor patterns, which are therefore analytically more manageable. These patterns are frequently called factors, dimensions, or components. In this study, the objective was to investigate to what extent the multiple manifestations of a major international actor's interest abroad could be concentrated into a limited number of dimensions of manifest interest.

6.6 Statistically, factor analysis groups together those variables that display a high degree of intercorrelation. This permits the researcher to infer the existence of a set of common underlying causes or influences. The resulting variable groupings, or common factors, become new, composite variables.

6.7 The initial output of factor analysis is the unrotated factor matrix, which consists of a series of columns containing variable loadings. Each of the columns defines a factor, and each factor is separate (uncorrelated) from the others. The variables that load high on a particular factor (usually $|0.50|$) define that factor's character. The number of factors in a factor matrix is the number of substantively meaningful independent patterns of relationships among the variables. For instance, a four-factor solution may be interpreted as evidence of few different kinds of influence or causes underlying the data. This solution may be used to classify data or to illuminate four empirically different concepts for describing the original information.

6.8 Each unrotated factor can be thought of as an axis projected through a cluster of variable vectors. The smaller the distance between the variable and the imaginary axis, the greater its loading (contribution) on the factor. Similarly, the closer the angle between two variable vectors, the stronger their relationship (product-moment correlation) is; conversely, variables that are unrelated to one another will be at right angles to each other. ^{2/}

6.9 In the unrotated matrix, the first factor axis is projected through the configuration of variable vectors to account for the greatest regularity in the data, i.e., the axis seeks the best possible fit with the maximum number of data points. Each successive axis is then fitted to best define the remaining regularity. As a result, the unrotated matrix usually compromises data distinctness for data comprehensiveness. By rotating the imaginary axes as a fixed structure, the investigator seeks to realign the axes with distinct clusters of variables.

6.10 Figures 6.1a and 6.1b have plotted the rotation of two factor axes (F_1 and F_2) against a set of eight hypothetical variables (depicted as vector points) across an undefined number of cases. The projection of each vector point on the factor axes is the loading of the respective variable.

6.11 Figure 6.1a demonstrates how, in the unrotated axis structure, the first factor (F_1) tends to seek out the most general pattern of interrelationships among the variables,

^{2/} The cosine of the angle between two vectors is equal to the product-moment correlation between the two variables represented by the vectors.

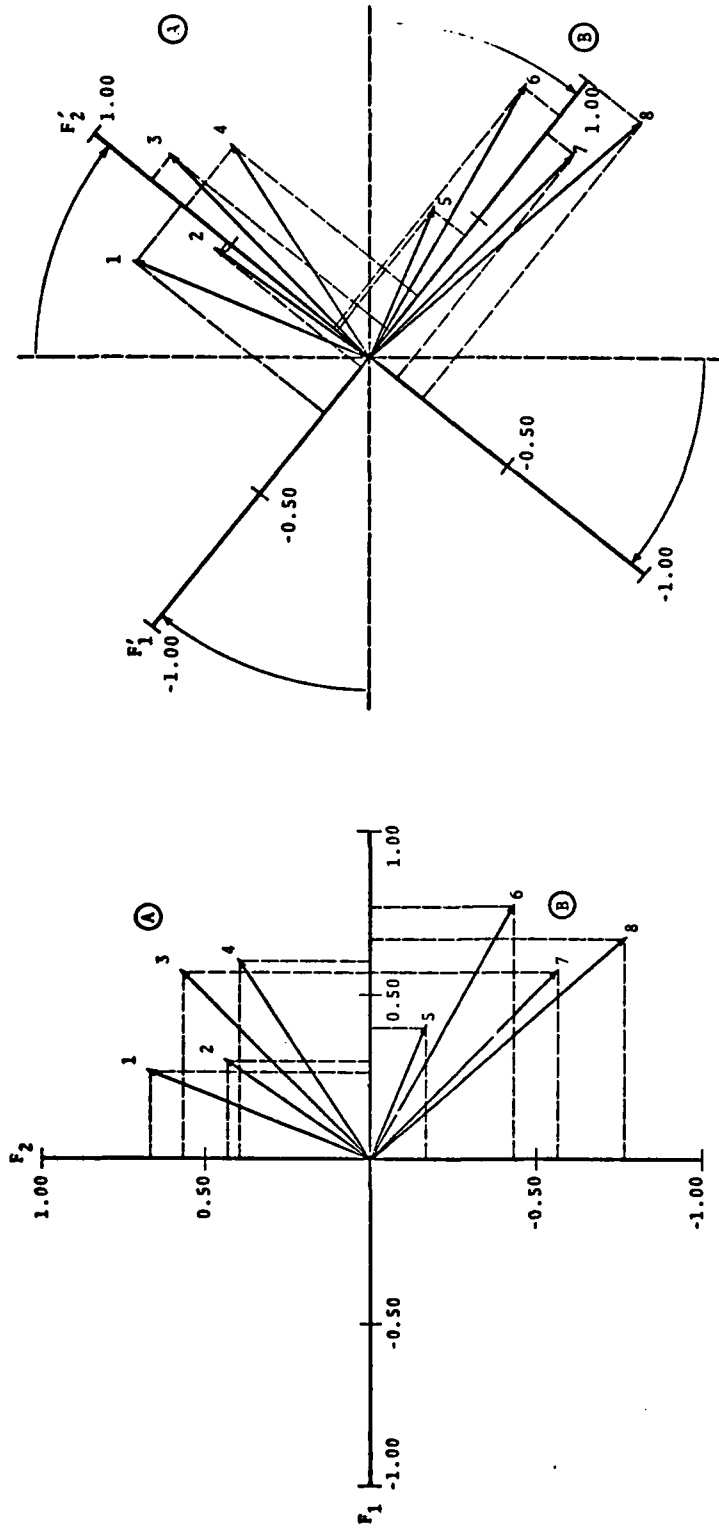

a. Factors F_1 and F_2

b. Factors F_1' and F_2'

FIGURE 6.1

REPRESENTATION OF ORTHOGONAL SIMPLE STRUCTURE ROTATION OF
EIGHT HYPOTHETICAL VARIABLES

(with arrows indicating direction and degree of rotation of factors)

with the remaining interdependencies defined by F_2 . Figure 6.1a also clarifies how data comprehensiveness fails to point out the separateness between the two clusters (A and B) of vector points. Variable loadings of clusters A and B on F_1 (dotted lines) would be roughly similar and would prevent the analyst from confirming their de facto distinctness.

6.12 In Figure 6.1b the F_1' - F_2' axis structure has been rotated clockwise until it has defined clusters involving a minimum number of highly intercorrelated variables. Instead of emphasizing general patterns involving the largest number of interdependent variables, the rotated solution has shifted the focus to patterns involving separate groups of variables, i.e., F_1' and F_2' .

6.13 The movement of the factor axes as a rigid structure, with each factor fixed to the origin at a right (orthogonal) angle, is called orthogonal rotation. When aligned with distinct clusters of variables, the orthogonal axis structure defines uncorrelated patterns of relationships.

6.14 Table 6.1 displays the final six-factor solution that was obtained by using factor analysis to determine the 1973 values for 23 primary and derived indicators of Soviet external involvement. Each of the six factors, or components, represents a discrete cluster of functionally related manifestations of Soviet activity abroad. Each of the factors, in turn, is orthogonal, or independent from the others. The high variable loadings (i.e., $\geq |0.50|$) denote the character of a particular factor, i.e., they may be interpreted as dimensional descriptors. They allow the investigator to assign generic labels to each of the factors.

TABLE 6.1
FINAL ROTATED FACTOR MATRIX OF MANIFEST SOVIET INTEREST DATA IN 1973

| Variable | Component | | | | | | Communi- nality |
|---|-----------|--------|--------|--------|--------|--------|--------------------|
| | 1 | 2 | 3 | 4 | 5 | 6 | |
| Foreign students in U.S.S.R. | 0.043 | -0.097 | -0.070 | 0.608* | 0.355 | 0.018 | 0.672 |
| Soviet arms sales (delivered) (U.S. \$M) | 0.922* | 0.015 | 0.005 | -0.259 | -0.048 | 0.112 | 0.932 |
| Soviet bilateral/multilateral military treaties in force | 0.023 | 0.852* | 0.057 | -0.032 | -0.049 | -0.084 | 0.739 |
| Soviet bilateral/multilateral treaties in force | 0.055 | 0.670* | 0.038 | -0.065 | -0.141 | 0.534* | 0.762 |
| Soviet economic assistance (delivered) (U.S. \$M) | 0.202 | -0.028 | -0.001 | 0.857* | -0.156 | 0.164 | 0.827 |
| Soviet economic technicians abroad | 0.428 | -0.026 | -0.023 | 0.760* | 0.064 | 0.208 | 0.809 |
| Soviet military personnel abroad | -0.063 | 0.657* | 0.382 | 0.053 | 0.099 | -0.174 | 0.625 |
| Soviet personnel under juris- diction of embassy | 0.005 | 0.147 | -0.002 | 0.156 | 0.024 | 0.867* | 0.799 |
| Soviet security assistance (delivered) (U.S. \$M) | 0.793* | 0.022 | 0.017 | 0.270 | -0.109 | 0.077 | 0.720 |
| Soviet tourists abroad | 0.000 | 0.907* | -0.052 | -0.036 | -0.030 | -0.077 | 0.833 |
| Value of Soviet imports | -0.009 | 0.831* | 0.068 | -0.025 | -0.060 | 0.389 | 0.851 |
| Value of Soviet exports | 0.012 | 0.874* | 0.101 | -0.011 | -0.061 | 0.252 | 0.842 |

TABLE 6.1 (Cont)

| Variable | Component | | | | | | Commu- nality |
|---|-----------|--------|--------|--------|--------|--------|------------------|
| | 1 | 2 | 3 | 4 | 5 | 6 | |
| Soviet military personnel abroad per country's population | -0.050 | 0.515* | 0.743* | 0.030 | 0.097 | -0.122 | 0.845 |
| Soviet personnel under jurisdiction of embassy per country's population | -0.007 | -0.060 | 0.101 | -0.183 | 0.613* | 0.366 | 0.556 |
| Soviet tourists abroad per country's population | 0.008 | 0.836* | -0.034 | -0.042 | -0.017 | -0.127 | 0.718 |
| Value of Soviet imports per country's total exports | 0.028 | 0.007 | 0.666* | -0.039 | -0.089 | 0.051 | 0.456 |
| Value of Soviet exports per country's total imports | 0.005 | -0.001 | 0.863* | -0.029 | 0.012 | 0.045 | 0.748 |
| Soviet economic assistance (delivered) per country's population | 0.156 | -0.012 | -0.007 | 0.717* | 0.010 | -0.111 | 0.551 |
| Soviet security assistance (delivered) per country's self-financed defense expenditures | 0.750* | -0.010 | -0.010 | 0.206 | 0.208 | -0.039 | 0.650 |
| Soviet security assistance (delivered) per country's population | 0.969* | 0.007 | -0.007 | 0.143 | 0.017 | -0.027 | 0.961 |
| Soviet arms sales (delivered) per country's population | 0.926* | 0.001 | -0.002 | 0.086 | 0.093 | -0.059 | 0.877 |

TABLE 6.1 (Cont)

| Variable | Component | | | | | | Communi- nality |
|---|-----------|--------|--------|--------|--------|--------|--------------------|
| | 1 | 2 | 3 | 4 | 5 | 6 | |
| Foreign students in U.S.S.R. per country's population | 0.082 | -0.069 | -0.093 | 0.128 | 0.811* | -0.169 | 0.723 |
| Soviet economic technicians abroad per country's popula- tion | 0.465 | -0.027 | -0.052 | 0.503* | 0.458 | -0.166 | 0.710 |

Note: The components are as follows:

1. Military assistance
2. Military commercial activity
3. Commercial penetration
4. Political activity
5. Political visibility
6. Diplomatic activity.

* Variable loadings equal to or greater than 0.500.

6.15 The last column shows the communalities of the variables. These figures present the amount of variation each of the variables has in common with all the others, i.e., they are an indication of the "relative uniqueness" of one variable in relation to the other variables. For example, the communality figure of 0.672 for "Foreign Students in USSR" means that 67% $[0.672 \times 100]$ of the Soviet intake of overseas academic students and technical trainees, measured for 123 nations, can be predicted from a knowledge of a country's values on the six factors and that 33% of this intake is unrelated to the other 22 measures of Soviet involvement.

6.16 Table 6.1 shows that the communalities for most variables are quite high, which indicates that they are closely related. This finding strengthens the investigator's confidence that the six factors are substantially meaningful.

FACTOR AND COMPOSITE SCORING

6.17 The third and final step in the factor analytic procedure was to score each of the countries in the data base on the individual major actors' manifest interest profiles, as they were defined by orthogonal factor rotation.

6.18 Individual dimensional scores were obtained using the formula $Y = XG$, where Y is the factor score matrix, X the standardized values of the cases (countries) on each variable, and G the transformation matrix. The matrices are defined as follows:

PRESEARCH INCORPORATED

- F is a matrix of eigenvectors, where each eigenvector is normalized to its eigenvalue, i.e., $FF' = \lambda$, where λ is a diagonal matrix of eigenvalues.
- The matrix $G = F\lambda^{-1}$, where the column vectors of G are obtained by dividing each column of F by its corresponding eigenvalue. 3/

6.19 Calculation of composite scores for all countries was accomplished by multiplying each country's individual dimensional scores by the pertinent final eigenvalues and then dividing the summed products of this computation by the sum of final eigenvalues.

6.20 The conceptual rationale for developing cross-national composite scores was based on the proposition that the total amount of variance accounted for by each of the six dimensions of the Soviet interest was a reasonable approximation of the "real world" composition of the Soviet interest.

6.21 Note that both the dimensional and composite country scores portray a relative rank-ordering of nations that is unique to the particular major actor examined. For example, a nation's score on Great Britain's manifest interest profile reflects the nation's position relative to other nations of British interest. This position can then be compared to the nation's relative location on the Japanese interest profile. The British and Japanese scores do not measure comparative

3/ See John P. Vande Geer, Introduction to Multivariate Analysis for the Social Sciences, San Francisco, W. H. Freeman and Co., 1971, pp. 128-155.

PRESEARCH INCORPORATED

absolute levels of manifest interest in the selected nation; they merely compare the amount of resources each country has invested, in relation to its worldwide interests, in the target country.

PRESEARCH INCORPORATED

APPENDIX
SOURCE DATA DOCUMENTATION

PRESEARCH INCORPORATED

| Variable | Year Available | Source | Point of Contact |
|---|--------------------|--|---|
| France | | | |
| <u>Political</u> No. of bilateral and multilateral treaties in force | 1968-1973 | P. Rohn, <u>World Treaty Index and Keesings Contemporary Archives</u> | U.S. Army Library The Pentagon Washington, D.C. |
| Value of development assistance (delivered) | 1968-1973 | Bettencourt, M., <u>Cooperation, Tome III</u> Ambassade de France, Service de Presse et d'Information, press releases | Andre Amand Directeur, Service de Presse et d'Information 972 Fifth Avenue New York, N.Y. 10021 |
| No. of technical assistance personnel abroad | 1971-1973 | Same as above | Same as above |
| No. of development volunteers abroad | 1969 and 1971-1973 | Same as above | Same as above |
| No. of cultural exchanges | 1970-1973 | <u>Boursiers Francais a l'Etranger (mimeo), (annual)</u> | Ministere des Affaires Etrangeres Direction Generale des Relations Culturelles Scientifiques et Techniques Services de la Diffusion et des Echanges Culturels 37 Quai d'Orsay 75700 Paris, France |

PRESEARCH INCORPORATED

| Variable | Year Available | Source | Point of Contact |
|---|----------------|---|---|
| France | | | |
| <u>Military</u> No. of military bilateral and multilateral treaties in force | 1968-1973 | P. Rohn, World Treaty Index and <u>Keesings Contemporary Archives</u> | U.S. Army Library The Pentagon Washington, D.C. |
| Value of arms sales (delivered) | 1968-1973 | DIA, Foreign Military Assistance (FOMA) (U), (annual) <u>SECRET/NOFORN</u> | Mrs. Mary Johnson DIA Library Arlington, Virginia Telephone OX-2-6156 |
| Value of security aid (delivered) | 1968-1973 | Same as above | Same as above |
| Military deployments abroad | 1968-1974 | Same as above | Same as above |
| <u>Economics</u> No. of tourists abroad | 1968-1973 | International Union of Official Travel Organizations, <u>International Travel Statistics</u> (annual) | International Union of Official Travel Organizations P.O.B. 7 1211 Geneva 20, Switzerland |
| Book value of direct private investments abroad | 1972 | U.N. <u>Statistical Yearbook</u> , (annual) | U.S. Army Library The Pentagon Washington, D.C. |
| | | U.S. Department of State, <u>Country Fact Sheets</u> | Mr. Mike Mercurio Department of State Information Systems Room 19A16C Washington, D.C. Telephone: 632-7981 |

PRESEARCH INCORPORATED

| Variable | Year Available | Source | Point of Contact |
|--|----------------|---|--|
| | | France | |
| Book value of direct private investments abroad (cont) | | Organization for Economic Co-operation and Development, Review of Development Co-operations, (annual) | Philip D. Berlin Head, Private Investment Section Organization for Economic Co-operation and Development 2 Rue Andre-Pascal 75775 Paris, France |
| | | <u>Evolution des Investissements Francais a l'Etranger</u> | Mme. Annie Julien-Durand Directeur-Adjoint, Departement des Etudes Economiques et de l'Information Banque de Francais du Commerce, Exterieur 21 Boulevard Haussman Paris 9c, France |
| Value of imports | 1968-1973 | International Monetary Fund (IMF), <u>Direction of Trade</u> , | Multics |
| | | Great Britain | |
| <u>Political</u> | | | |
| No. of bilateral and multilateral treaties in force | 1968-1973 | P. Rohn, World Treaty Index and <u>Keesings Contemporary Archives</u> | U.S. Army Library The Pentagon Washington, D.C. |
| No. of embassy personnel abroad | 1968-1973 | House of Commons, <u>Civil Estimates</u> (annual) | Her Majesty's Stationary Office Pendragon House 200 University Avenue Palo Alto, California 94301 |

PRESEARCH INCORPORATED

| Variable | Year Available | Source | Point of Contact |
|--|----------------|---|---|
| Value of development assistance (loans and grants) | 1945-1973 | <p style="text-align: center;">Great Britain</p> <p>Central Statistical Office, <u>Annual Abstract of Statistics</u></p> <p>Ministry of Overseas Development, <u>United Kingdom Aid Memorandum Statistical Annexe, Part Two: Finance (annual)</u></p> <p>Foreign and Commonwealth Office, <u>Overseas Development Administration, British Aid Statistics (tri-annual)</u></p> | <p>Same as above</p> <p>Mr. S. G. R. Thomas Statistics Division Ministry of Overseas Development Eland House Stag Place London SW1, Great Britain</p> <p>Overseas Development Administration Overseas Manpower Division Eland House Stag Place London SW1, Great Britain</p> |
| No. of technical assistance personnel abroad | 1968-1973 | <p>Ministry of Overseas Development, <u>United Kingdom Aid Memorandum Statistical Annexe, Part Two: Finance (annual)</u></p> <p>Foreign and Commonwealth Office, <u>Overseas Development Administration, British Aid Statistics (tri-annual)</u></p> | <p>Mr. S. G. R. Thomas Statistics Division Ministry of Overseas Development Eland House Stag Place London SW1, Great Britain</p> <p>Overseas Development Administration Overseas Manpower Division Eland House Stag Place London SW1, Great Britain</p> |

PRESEARCH INCORPORATED

| Variable | Year Available | Source | Point of Contact |
|--|----------------|---|--|
| Great Britain | | | |
| No. of students sponsored from abroad | 1968-1973 | Same as above | Same as above |
| No. of development volunteers abroad | 1968-1973 | Same as above | Same as above |
| No. of cultural exchanges | 1968-1973 | <u>The British Council</u> , annual report | R. P. H. Davies Director, Information Department The British Council 10 Spring Gardens London SW1, Great Britain |
| <u>Military</u> No. of military bilateral and multi-lateral treaties in force | 1968-1973 | P. Rohn, <u>World Treaty Index and Keesings Contemporary Archives</u> | U.S. Army Library The Pentagon Washington, D.C. |
| Value of arms sales (delivered) | 1968-1973 | DIA, <u>Foreign Military Assistance (FOMA) (U)</u> , (annual), <u>SECRET/NOFORN</u> | Mrs. Mary Johnson DIA Library Arlington, Virginia Telephone OX-2-6156 |
| Value of security assistance (delivered) | 1968-1972 | Same as above | Same as above |
| | | <u>House of Commons, Civil Estimates (annual)</u> | Her Majesty's Stationary Office Pendragon House 220 University Avenue Palo Alto, California 94301 |

PRESEARCH INCORPORATED

| Variable | Year Available | Source | Point of Contact |
|--|----------------|---|--|
| Great Britain | | | |
| <u>Economics</u> No. of tourists abroad | 1968-1973 | International Union of Official Travel Organizations, <u>International Travel Statistics (annual)</u> U.N. Statistical Yearbook <u>Annual Report on Immigration Statistics</u> | International Union of Official Travel Organizations P.O.B. 7 1211 Geneva 20, Switzerland U.S. Army Library The Pentagon Washington, D.C. Her Majesty's Stationary Office Pendragon House 220 University Avenue Palo Alto, California 94301 |
| Book value of direct private investment abroad | 1962-1972 | <u>OECD, Annual Review of Development Co-operation</u> Bank of England, Britain's <u>International Investment Position</u> | Philip D. Berlin Head, Private Investment Section OECD 2 Rue Andre-Pascal 75775 Paris, France A. M. Porter Intelligence Department Bank of England Threadneedle Street London SW1, Great Britain |
| Value of imports and exports | 1968-1973 | <u>International Monetary Fund, Direction of Trade</u> | Multics |

PRESEARCH INCORPORATED

| Variable | Year Available | Source | Point of Contact |
|---|------------------------|---|---|
| Japan | | | |
| <u>Political</u> No. of bilateral and multilateral treaties in force | 1968-1973 | P. Rohn, World Treaty Index and <u>Keesings Contemporary Archives</u> | U.S. Army Library The Pentagon Washington, D.C. |
| No. of embassy personnel abroad | 1968-1969 1971-1974 | Ministry of Foreign Affairs, Department of Immigration, Census of Overseas Japanese Nationals (in Japanese), (annual) | Mr. Niichi Nakaichi Head, Registration Division Immigration Bureau Ministry of Justice 1-1-1 Kasumigaseki Chiyoda-ku, Tokyo, Japan |
| Value of development assistance (loans and grants) | 1961-1968 1971 | Ministry of Foreign Affairs, Categories of Japanese Economic Aid | Mr. Yuji Ooka Consul of Japan Consulate General of Japan Suite 1501 400 Colony Square Atlanta, Georgia 30361 |
| No. of technical assistance personnel abroad | 1969-1973 | Computer tabulations Same as above | Mr. Bevan B. Stein Head, Reporting Systems Div. OECD 2 Rue Andre-Pascal 75775 Paris, France Same as above |

PRESEARCH INCORPORATED

| Variable | Year Available | Source | Point of Contact |
|---|------------------------|--|---|
| Japan | | | |
| No. of residents abroad | 1968-1969 1971-1974 | Ministry of Foreign Affairs, Department of Immigration, <u>Census of Overseas Japanese Nationals (in Japanese), (annual)</u> | Mr. Niichi Nakaichi Head, Registration Division Immigration Bureau Ministry of Justice 1-1-1 Kasumigaseki Chiyoda-ku, Tokyo, Japan |
| No. of cultural exchanges | | International Society for Education Information, <u>International Culture</u> | Miss Michiko Kaya Executive Director, International Society for Education Information No. 7-8, 2 Chome Shintomi, Chuo-ku Tokyo, Japan |
| <u>Military</u> No. of military bi-lateral and multi-lateral treaties in force | 1968-1971 | P. Rohn, <u>World Treaty Index and Keesings Contemporary Archives</u> | U.S. Army Library The Pentagon Washington, D.C. |
| Value of arms sales (delivered) | 1968-1973 | Defense Intelligence Agency, <u>Foreign Military Assistance (FOMA) (U), (annual), SECRET/NOFORN</u> | Mrs. Mary Johnson, DIA Library, Washington, D.C. Telephone OX-2-6156 |
| Value of security aid (delivered) | 1968-1973 | Same as above | Same as above |

PRESEARCH INCORPORATED

| Variable | Year Available | Source | Point of Contact |
|--|----------------|---|---|
| Japan | | | |
| <u>Economic</u> No. of tourists abroad | 1968-1973 | International Union of Official Travel Organi- zations, <u>International Travel Statistics</u> | International Union of Official Travel Organi- zations P.O.B. 7 1211 Geneva 20, Switzerland |
| Book value of direct private investment abroad | 1961-1972 | <u>U.N. Statistical Yearbook</u> Export-Import Bank of Japan, <u>Japanese Direct Private In- vestment Abroad (annual)</u> | U.S. Army Library The Pentagon Washington, D.C. Mr. I. Hatakeyama Administration Department The Export-Import Bank of Japan 1-5-5 Otemachi, Chiyoda-ku Tokyo 100, Japan |
| No. of government sponsored and funded technical exchanges | 1969-1970 | OECD, <u>Annual Review of De- velopment Co-operation</u> OECD, <u>Technical Co-operation, Statistical Series C</u> | Mr. Philip D. Berlin Head, Private Investment Section OECD 2 Rue Andre-Pascal 75775 Paris, France Same as above |

PRESEARCH INCORPORATED

| Variable | Year Available | Source | Point of Contact |
|--|--------------------|--|--|
| Japan | | | |
| Value of imports and exports | 1968-1973 | International Monetary Fund, (IMF), Direction of Trade | Multics |
| Union of Soviet Socialist Republics | | | |
| <u>Political</u> | | | |
| No. of bilateral and multilateral treaties in force | 1968-1973 | P. Rohn, <u>World Treaty Index and Keatings Contemporary Archives</u> | U.S. Army Library The Pentagon Washington, D.C. |
| No. of embassy personnel abroad | 1968-1973 | CIA, Directorate of Plans, <u>Soviet Checklist</u> , (U), SECRET/NOFORN | CIA Document Services Branch |
| Value of development assistance (grants, credit and discounts) | 1968-1973 | U.S. Intelligence Board, Economic Intelligence Committee, Aid and Trade Activities of <u>Communist Countries in Less Developed Areas of the Free World</u> (U), (annual), <u>Statistical Supplement to EICR 14-S27</u> , SECRET/NOFORN | Same as above |
| No. of technical assistance personnel abroad | 1968 and 1970-1973 | DIA, <u>Foreign Military Assistance (FOMA)</u> (U), (annual), SECRET/NOFORN | Mrs. Mary Johnson, DIA Library Arlington, Va. Telephone OX-2-6156 |
| No. of students from abroad | 1970-1973 | U.S. Intelligence Board, Economic Intelligence Committee, Aid and Trade Activities of <u>Communist Countries in Less Developed Areas of the Free World</u> (U), (annual), SECRET/NOFORN | CIA Document Services Branch |

PRESEARCH INCORPORATED

| Variable | Year Available | Source | Point of Contact |
|---|----------------|---|--|
| Union of Soviet Socialist Republics | | | |
| <u>Military</u> No. of military bilateral and multilateral treaties in force | 1968-1973 | P. Rohn, World Treaty Index and <u>Keesings Contemporary Archives</u> | U.S. Army Library The Pentagon Washington, D.C. |
| Value of arms sales (delivered) | 1968-1973 | U.S. Intelligence Board, Economic Intelligence Committee, Aid and Trade Activities of Communist Countries in Less Developed Areas of the Free World (U), (annual), Statistical Supplement to EICR 14-S27, SECRET/NOFORN | CIA Document Services Branch |
| Value of security aid (delivered) | 1968-1973 | DIA, Foreign Military Assistance (FOMA) (U), (annual), SECRET/NOFORN | Mrs. Mary Johnson, DIA Library Arlington, Va. Telephone OX-2-6156 |
| Military deployments abroad | 1968-1974 | Same as above | Same as above |
| <u>Economic</u> No. of tourists abroad | 1968-1973 | DIA, Military Intelligence Summary (U), SECRET/NOFORN | Same as above |
| | | International Union of Official Travel Organizations, International Travel Statistics (annual) | International Union of Official Travel Organizations, P.O.B. 7 1211 Geneva 20, Switzerland |

PRESEARCH INCORPORATED

| Variable | Year Available | Source | Point of Contact |
|---|----------------|--|---|
| West Germany | | | |
| <u>Economic</u> No. of tourists abroad | 1968-1973 | International Union of Official Travel Organizations, <u>International Travel Statistics (annual)</u> U.N. Statistical Yearbook | International Union of Official Travel Organizations P.O.B. 7 1211 Geneva 20, Switzerland U.S. Army Library The Pentagon Washington, D. C. |
| Book value of direct private investments abroad | 1966-1973 | Statistisches Bundesamt/ Wiesbaden, Statistisches Jahrbuch fuer die <u>Bundesrepublik Deutschland (annual)</u> Deutsche Bundesbank, Runderlass Ausseiwirtschaft betreffend iv 1: <u>Vermögensanlagen Gebietsansaessiger in Fremden Wirtschaftsgebieten (issued annually in April) and Statistische Beihefte Reihe Zahlungs- bilanzstatistik (annual)</u> | Same as above Deutsche Bundesbank 6 Frankfurt am Main 1 Wilhelm-Epstein Strasse 14 West Germany |
| Value of imports and exports | 1968-1973 | <u>International Monetary Fund (IMF), Direction of Trade</u> | Multics |

PRESEARCH INCORPORATED

| Variable | Year Available | Source | Point of Contact |
|---|----------------|--|---|
| West Germany | | | |
| No. of development assistance volunteers | 1972-1973 | Same as above | Same as above |
| | | Computer Tabulations | Bevan B. Stein Head, Reporting Systems Division OECD 25 Rue Andre-Pascal 75775 Paris, France |
| No. of students from abroad | 1972-1973 | Sekretariat der Kulturministerkonferenz, Der Schulbesuch <u>Auslaendischer Schueler in der Bundesrepublik Deutschland</u> (annual) | Herrn. Schumacher Sekretariat Der Staendigen Konferenz 53 Bonn, Nassestrasse 8, West Germany |
| <u>Military</u> No. of military bilateral and multilateral treaties in force | 1968-1973 | Bundesminister der Justiz, Fundstellennachweis <u>B--Voelkerrechtliche Vereinbarungen und Vertraege mit der DDR</u> (annual) P. Rohn, <u>World Treaty Index</u> | Auswaertiges Amt Attn. Dr. Goeckel 53 Bonn 1 West Germany |
| Value of arms sales (delivered) | 1968-1970 | DIA, <u>Foreign Military Assistance FOIA (U)</u> , (annual), <u>SECRET/NOFORN</u> | U.S. Army Library The Pentagon Washington, D.C. Mrs. Mary Johnson, DIA Library Arlington, Va. Telephone OX-2-6156 |

PRESEARCH INCORPORATED

| Variable | Year Available | Source | Point of Contact |
|---|-----------------------------------|--|---|
| Union of Soviet Socialist Republics | | | |
| | | <u>U.N. Statistical Yearbook</u> | U.S. Army Library The Pentagon Washington, D.C. |
| Value of imports and exports | 1968-1973 | International Monetary Fund, (IMF) <u>Direction of Trade</u> | Multics |
| West Germany | | | |
| <u>Political</u> No. of bilateral and multilateral treaties in force | 1968-1973 | Bundesminister der Justiz, Fundstellennachweis B--Voel- <u>kerrechtliche Vereinbarungen</u> <u>und Vertraege mit der DDR</u> (annual) | Dr. Treviranus Auswaertiges Amt 53 Bonn Adenauer Allee, 99-103 West Germany |
| Value of development assistance (loans and grants) | 1950-70 (cumulative) 1971-1973 | Bundesministerium fuer Wirtschaftliche Zusammenarbeit, Bilaterale Oeffentliche En- <u>twicklungshilfe (Zuwendungen</u> <u>und Netto-Kredite) der BRD</u> <u>an Entwicklungslaender</u> 1950-1973 | Herrn. Matthias Weiter Planning Group Bundesministerium fuer Wirtschaftliche Zusammenarbeit 53 Bonn Friedrich Ebert Allee 114-116 West Germany |
| No. of technical assistance personnel abroad | 1972-1973 | OECD, <u>OECD Questionnaire</u> (annual) | Same as above |
| No. of students from abroad | 1972-1973 | Same as above | Same as above |

