

AD-A104 313

TECHNICAL LIBRARY

AD A104 313

TECHNICAL REPORT ARLCB-TR-81035

ACTIVATION OF SUPERALLOYS AND STAINLESS STEELS FOR CHROMIUM PLATING

W. Baldauf
E. S. Chen

August 1981

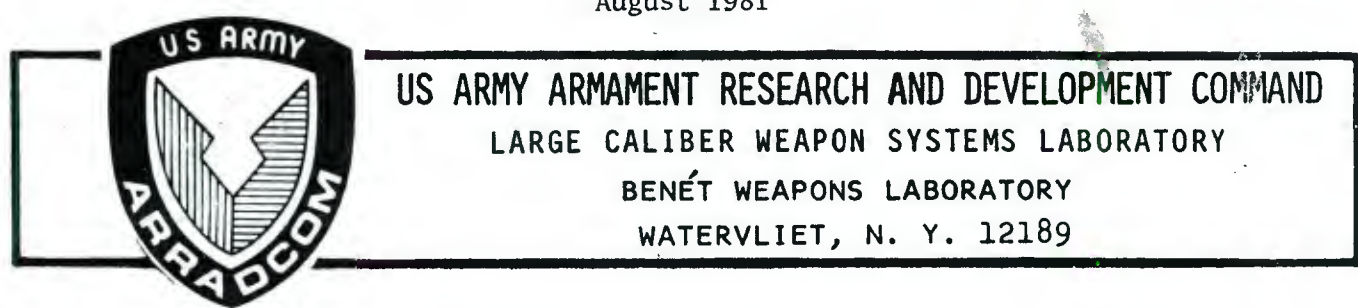

AMCMS No. 611102T1600011

DA Project No. 1L161102AH60

PRON No. 1A0215601A1A

APPROVED FOR PUBLIC RELEASE; DISTRIBUTION UNLIMITED

DISCLAIMER

The findings in this report are not to be construed as an official Department of the Army position unless so designated by other authorized documents.

The use of trade name(s) and/or manufacture(s) does not constitute an official indorsement or approval.

DISPOSITION

Destroy this report when it is no longer needed. Do not return it to the originator.

REPORT DOCUMENTATION PAGE		READ INSTRUCTIONS BEFORE COMPLETING FORM
1. REPORT NUMBER ARLCB-TR-81035	2. GOVT ACCESSION NO.	3. RECIPIENT'S CATALOG NUMBER
4. TITLE (and Subtitle) ACTIVATION OF SUPERALLOYS AND STAINLESS STEELS FOR CHROMIUM PLATING		5. TYPE OF REPORT & PERIOD COVERED FINAL
		6. PERFORMING ORG. REPORT NUMBER
7. AUTHOR(s) W. Baldauf E. S. Chen		8. CONTRACT OR GRANT NUMBER(s)
9. PERFORMING ORGANIZATION NAME AND ADDRESS US Army Armament Research & Development Command Benet Weapons Laboratory, DRDAR-LCB-TL Watervliet, NY 12189		10. PROGRAM ELEMENT, PROJECT, TASK AREA & WORK UNIT NUMBERS AMCMS No. 611102T1600011 DA Project No. 1L161102AH60 PRON No. 1A0215601A1A
11. CONTROLLING OFFICE NAME AND ADDRESS US Army Armament Research & Development Command Large Caliber Weapon Systems Laboratory Dover, NJ 07801		12. REPORT DATE August 1981
		13. NUMBER OF PAGES 13
14. MONITORING AGENCY NAME & ADDRESS (if different from Controlling Office)		15. SECURITY CLASS. (of this report) UNCLASSIFIED
		15a. DECLASSIFICATION/DOWNGRADING SCHEDULE
16. DISTRIBUTION STATEMENT (of this Report) Approved for public release; distribution unlimited.		
17. DISTRIBUTION STATEMENT (of the abstract entered in Block 20, if different from Report)		
18. SUPPLEMENTARY NOTES Presented at Symposium on Plating on Difficult to Plate Metals, New Orleans, LA, 30-31 October 1980. Published in proceedings of the symposium.		
19. KEY WORDS (Continue on reverse side if necessary and identify by block number) Activation Electrodeposition Adhesion Stainless Steel Chromium Plating Superalloys		
20. ABSTRACT (Continue on reverse side if necessary and identify by block number) The adhesion of electrodeposited chromium on cobalt, nickel and iron-nickel based superalloys such as CG-27, Haynes alloy 25, and Udimet 700, as well as stainless steels was investigated. A number of pretreatments were used to activate these alloys. The results show that a hydrofluoric-sulfuric acid pretreatment used anodically produces excellent adhesion. A qualitative adhesion test, named the "Groove Test" was developed to evaluate the adhesion of thick deposits of chromium on metallic substrates. The development of this test is described.		

SECURITY CLASSIFICATION OF THIS PAGE(When Data Entered)

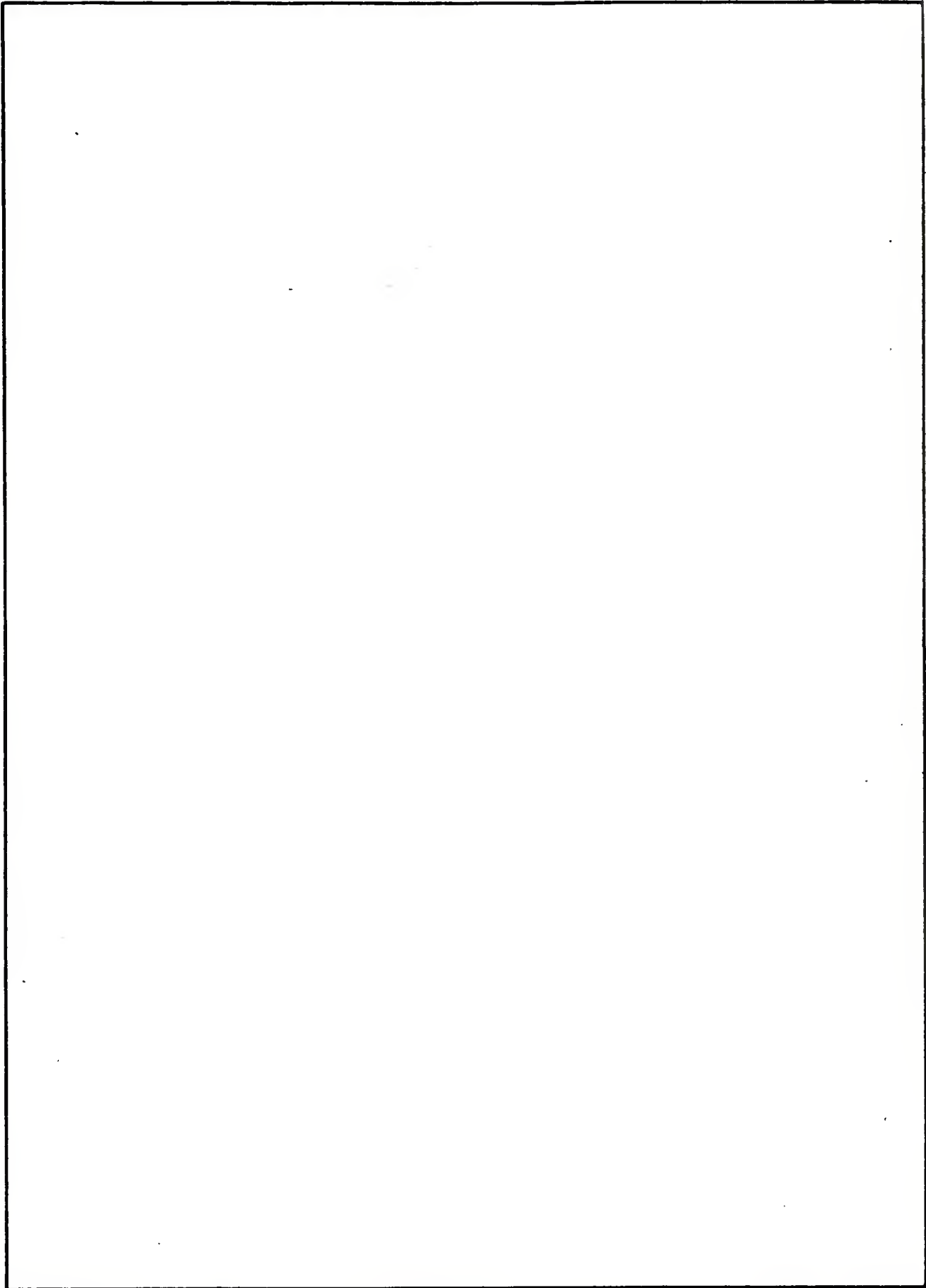

SECURITY CLASSIFICATION OF THIS PAGE(When Data Entered)

TABLE OF CONTENTS

	<u>Page</u>
INTRODUCTION	1
EXPERIMENTAL	2
Plating Procedure	2
Adhesion Testing	2
RESULTS AND DISCUSSIONS	3
CONCLUSIONS	6
REFERENCES	7

TABLES

I. PRIMARY COMPOSITION OF SELECTED SUPERALLOYS AND STAINLESS STEELS ¹⁵	8
II. ADHESION OF HC CHROMIUM ON SUPERALLOYS	9
III. ADHESION OF HC CHROMIUM ON U-700 AS A FUNCTION OF ETCHING TIME AND HYDROFLUORIC ACID	10

LIST OF ILLUSTRATIONS

1. Determining adhesion using the Shaper Groove Test. Surface grinding a superalloy specimen for chromium plating.	11
1a. Adhesion testing by cutting grooves across a chromium plated specimen.	12
2. Shaper Groove Test of LC chromium (A) and (B) and HC Chromium (C) and (D) on Modified 4340 Steel Substrates.	13

INTRODUCTION

The usefulness of superalloys in certain defense oriented applications can be improved greatly by electroplating a coating of chromium to change the surface properties. Unfortunately, superalloys pose special problems for electroplating; these alloys, like stainless steels, are readily passivated by the formation of surface oxide films. The oxide films can reduce deposit adhesion^{1,2} and special processing is necessary to remove the films prior to plating.

A number of processes are available for activating stainless steels for plating.³⁻⁹ This information is generalized in ASTM Designation B254-53³ and includes (a) cathodic or anodic treatments, (b) immersion treatments and (c) simultaneous activation using a strike intermediate layer. While superalloys are similar to stainless steels, it is not known whether the same activating procedures are applicable. The limited number of references on superalloys^{4,9,10} suggests the need for an intermediate strike layer in a viable activating process. The success of treating active-metal substrates with strike plating is well documented.¹² However, if the alloy is intended for use in a high temperature environment, the presence of an intermediate layer may be a detriment.

The present project was undertaken with two objectives in mind: the first is to develop an activation process for treating iron, nickel and cobalt-base superalloys for chromium plating without the need for a strike layer and the second is to develop a simple qualitative test for evaluating the adhesion of thick chromium deposits.

References are listed at the end of this report.

EXPERIMENTAL

Plating Procedure

All chemicals were of reagent grade and used without further purification. The chromium solution was prepared by dissolving 250 g/l of chromic acid and 2.5 g/l of sulfuric acid in distilled water. Cylindrical samples measuring three-fourths of an inch in diameter and one inch long were machined from CG-27, HS-25 and U-700 bar stock. The circumferential area of the samples is masked with heat shrinkable polypropylene tubing exposing only the flat end face for plating. No precleaning procedure was used prior to surface activating because the sample was used immediately following surface grinding. The samples are activated using acid solutions and techniques summarized in Table II. The plating experiments were conducted in a two liter beaker using a platinum anode, cathode rotation and no external mechanical agitation. High contraction (HC) chromium was plated at a current density of 31 A/dm² and a solution temperature of 55 ± 1°C while low contraction (LC) chromium was plated at 150 A/dm² and 85 ± 1°C.

Adhesion Testing

A new qualitative test was used to evaluate the adhesion of HC and LC chromium on superalloy substrates. The shaper groove test was designed specifically for use with thick brittle coatings such as chromium but was found to be also applicable to ductile coatings. The test procedure is illustrated in Figure 1. A cylindrical sample is secured in a parallel bar holder for surface grinding. The use of a parallel bar holder insures that the sample can be removed and repositioned without changing surface alignment. After grinding, the sample is masked and activated for chrome plating. Chromium is

deposited to a thickness of 75 μ after which the sample is returned to the parallel bar holder and secured. A small metal shaper equipped with a carbide tool is used to cut parallel grooves across the plated surface to a depth just below the interface. The degree of adhesion is evaluated with the aid of a low power optical microscope. The conditions best suited for this test were determined by studying chromium deposits of varying thicknesses (25 to 150 μ), grooves of different depths (0.125 to 1 mm from the interface), distance of groove separation (0.75 to 2.5 mm) and different speeds of the cutting tool. The best results were obtained with the use of a 75 μ thick deposit with the parallel grooves cut at a depth of 175 μ from the interface at a separation of 1 mm using a traversing tool speed of about 7.5 cm/sec.

RESULTS AND DISCUSSIONS

The performance of the shaper groove test was characterized by examining chromium coatings on modified 4340 steel substrates to determine test procedures (see Adhesion Testing, Experimental Section) and to establish a data classification system. Typical results of the shaper groove test are illustrated in Figures 2A and 2B for LC chromium deposits and Figures 2C and 2D for HC chromium deposits. Although qualitative, this test is sufficiently sensitive to differentiate among the following four classes of adhesion:

(1) Excellent - fracture occurs only within the chromium layer or the coating on the land remains undamaged. (2) Good - fracture occurs predominantly in the chromium layer. (3) Poor - fracture occurs predominantly at the interface. (4) No adhesion - coating detaches completely at the interface or spalls during plating. Using this classification, the adhesion depicted in

photographs 2A and 2C would be judged excellent because the coating remained undamaged after grooving. Photograph 2B also shows excellent adhesion on the basis that failure is completely interchromium. Photograph 2D shows a case of poor adhesion where failure is predominantly at the interface. This system of classification was applied to evaluate the adhesion of chromium or superalloys and stainless steels after various activation treatments.

The composition of the superalloys used in this study is given in Table I. The composition of several stainless steels is also included for comparison. These alloys contain large amounts of nickel, cobalt, chromium and molybdenum. It follows that treatments which are suitable for activating these elements for plating may also apply to superalloys. Potential treatments were selected on this basis, i.e., sulfuric acid for activating nickel substrates, chromic acid plating solution for chromium substrates and hydrofluoric acid for the less common metals.

The results of the adhesion testing are shown in Table II. Run #1 establishes the adhesion obtained for superalloy substrates exposed only to surface grinding. The fact that a freshly machined surface produces some adhesion is encouraging and suggests that activation without an intermediate strike layer is a distinct possibility. However, a search of the literature revealed only one process which does not employ strike plating in the activation step.⁴ This treatment, run #2, consists of a one minute dip in a 20 percent hydrochloric acid solution, water rinse, 1/2 minute immersion in a 67 percent nitric acid solution, water rinse, 1/2 minute immersion in chromic acid plating solution and plate in the same chrome solution. For U-700 and HS-25, the resulting adhesion is no better than that obtained with a freshly ground sur-

face; however, the adhesion is excellent on CG-27. Anodic and cathodic treatments in a chromic acid plating solution, run #3 and 4, produced good adhesion in CG-27 and no adhesion on U-700 and HS-25. The good adhesion obtained with CG-27 is attributable to the high iron content in this alloy; chromic acid plating solution is known to be effective for activating iron alloys. Anodic treatments using 30 percent, 60 percent and concentrated sulfuric acid solutions did not promote adhesion. A slight increase in adhesion was obtained in treating CG-27 with 60 percent sulfuric acid solution by extending the etching time from one to two minutes. Other processes investigated include a cathodic treatment with a mixture of 30 percent sulfuric acid and 5 percent hydrofluoric acid recommended for stainless steels¹³ and the same formulation used anodically which is reportedly excellent for the simultaneous activation of landing gear steel and nickel plated surfaces.¹⁴ The results with both procedures were disappointing.

An activation solution that has not been reported and presumably untried is 65 percent sulfuric acid and 5 percent hydrofluoric acid. This solution produced excellent adhesion on all three superalloys using a one minute anodic etch at 21°C and 31 A/dm². An intermediate water rinse before chromium plating is undesirable; rinsing was found to decrease adhesion on all three superalloys.

The effects of etching time and hydrofluoric acid concentration on the adhesion of chromium on U-700 are shown in Table III. The hydrofluoric acid concentration was varied from 1.25 to 7 percent while etching time was changed from 15 to 120 seconds. Sulfuric acid content was maintained at 65 percent since a lower concentration, i.e. 30 percent, was proven ineffective while a

higher concentration will increase solution viscosity and reduce conductivity. Except for the inconsistent adhesion results obtained with the 15 second etch, all of the remaining combinations produces excellent adhesion. From our view, a 30 second anodic etch at 31 A/dm^2 in a solution containing 65 percent sulfuric acid and 5 percent hydrofluoric acid is favored. The procedure was also tested on a selected group of stainless steels. The resulting adhesion of chromium on 304, 316, and 410 stainless steels was found to be excellent.

CONCLUSIONS

(1) Chromic acid plating solutions operated anodically or cathodically were not effective for activating superalloys for chromium plating.

(2) Solutions of sulfuric acid, 30 percent, 60 percent and concentrated, were also not suitable for treating superalloys for chromium plating.

(3) Excellent adhesion was obtained using solutions containing sulfuric acid at 65 vol percent and hydrofluoric acid between 1.25 to 7 vol percent. Activation is conducted at a current density of 31 A/dm^2 for a period of 30 to 120 seconds.

REFERENCES

1. L. Serota, *Metal Finishing*, 58 (9), 69 (1960).
2. H. B. Linford and D. O. Feder, *Plating*, 41, 279 (1954).
3. ASTM Designation B254-53, "Preparation of and Plating Stainless Steels," September (1964).
4. *Electroplating Engineering Handbook*, 3rd Edition, A. K. Graham, Ed., Van Nostrand Reinhold Co., 203 (1971).
5. I. Friedman, *Plating*, 54, 1035 (1967).
6. U.S. Patent 3,654,099 (1972).
7. U.S. Patent 3,645,861 (1972).
8. U.S. Patent 3,694,326 (1972).
9. U.S. Patent 3,642,586 (1972).
10. U.S. Patent 3,338,803 (1967).
11. U.S. Patent 3,726,773 (1973).
12. J. B. Berkowitz and N. H. Emerson, *Plating Methods*, NASA SP-5114 (1972).
13. *Metal Finishing Handbook*, 77 (13), January (1979).
14. G. T. Sink, *Plating and Surface Finishing*, 63 (8), 20 (1976).
15. *Metal Progress Databook*, 116 (1) (1979).

TABLE I. PRIMARY COMPOSITION OF SELECTED SUPERALLOYS AND STAINLESS STEELS¹⁵

	Ni	Co	Fe	Cr	Mo	Mn	Ti	Al	W	C	Si	P	S
U-700	Bal.	18.5	0.5	15	5.0	-	3.5	4.4	-	0.07	-	-	-
HS-25	10	Bal.	3.0	20	-	1.5	-	-	15	0.10	0.5	-	-
CG-27	38	-	Bal.	13	5.5	0.1	2.5	1.5	-	0.05	0.1	-	-
304	8-10.5	-	-	18-20	-	2.0	-	-	-	0.08	1.0	0.045	0.030
316	10-14	-	-	16-18	2-3	2.0	-	-	-	0.08	1.0	0.045	0.030
410	-	-	Bal.	12	-	-	-	-	-	0.02	0.8	0.006	0.025

TABLE II. ADHESION OF HC CHROMIUM ON SUPERALLOYS

Etching Solution	Pretreatment Condition	CG-27	Adhesion U-700	HS-25
None	Freshly Ground Surface	Poor	Poor	Poor
20% HCl, 67% HNO ₃ , 250/ 2.5 g/l; CrO ₃ /H ₂ SO ₄	Immersion, water rinse 1 min., 1/2 min., 1/2 min.	Poor	Poor	Poor
250/2.5 g/l; CrO ₃ /H ₂ SO ₄	Cathodic, 2.4 v, 15 min.	Good	No ad	-
250/2.5 g/l; CrO ₃ /H ₂ SO ₄	Anodic, 31 A/dm ² , 2 min.	Good	No ad	No ad
30% H ₂ SO ₄	Anodic, 31 A/dm ² , 1 min.	No ad	Poor	No ad
65% H ₂ SO ₄	Anodic, 31 A/dm ² , 1 min.	Poor	Poor	Poor
65% H ₂ SO ₄	Anodic, 31 A/dm ² , 2 min.	Good	Poor	Poor
Conc. H ₂ SO ₄	Anodic, 31 A/dm ² , 1 min.	No ad	Poor	Poor
Conc. H ₂ SO ₄	Cathodic, 31 A/dm ² , 1 min.	No ad	Poor	No ad
30% H ₂ SO ₄ + 5% HF	Anodic, 31 A/dm ² , 2 min.	Ex	Poor	Poor
30% H ₂ SO ₄ + 5% HF	Cathodic, 31 A/dm ² , 2 min.	No ad	No ad	No ad
65% H ₂ SO ₄ + 5% HF	Anodic, 31 A/dm ² , 1 min.	Ex	Ex	Ex

TABLE III. ADHESION OF HC CHROMIUM ON U-700 AS A FUNCTION OF
ETCHING TIME AND HYDROFLUORIC ACID CONCENTRATION*

HF (%)	Time (sec)	15	30	60	120
7		Good	Ex	Ex	-
5		Poor	Ex	Ex	Ex
2.5		Ex	Ex	Ex	-
1.25		Poor	Ex	Ex	-

*All solutions contain 65% sulfuric acid. Etching was conducted anodically at a current density of 31 A/dm².

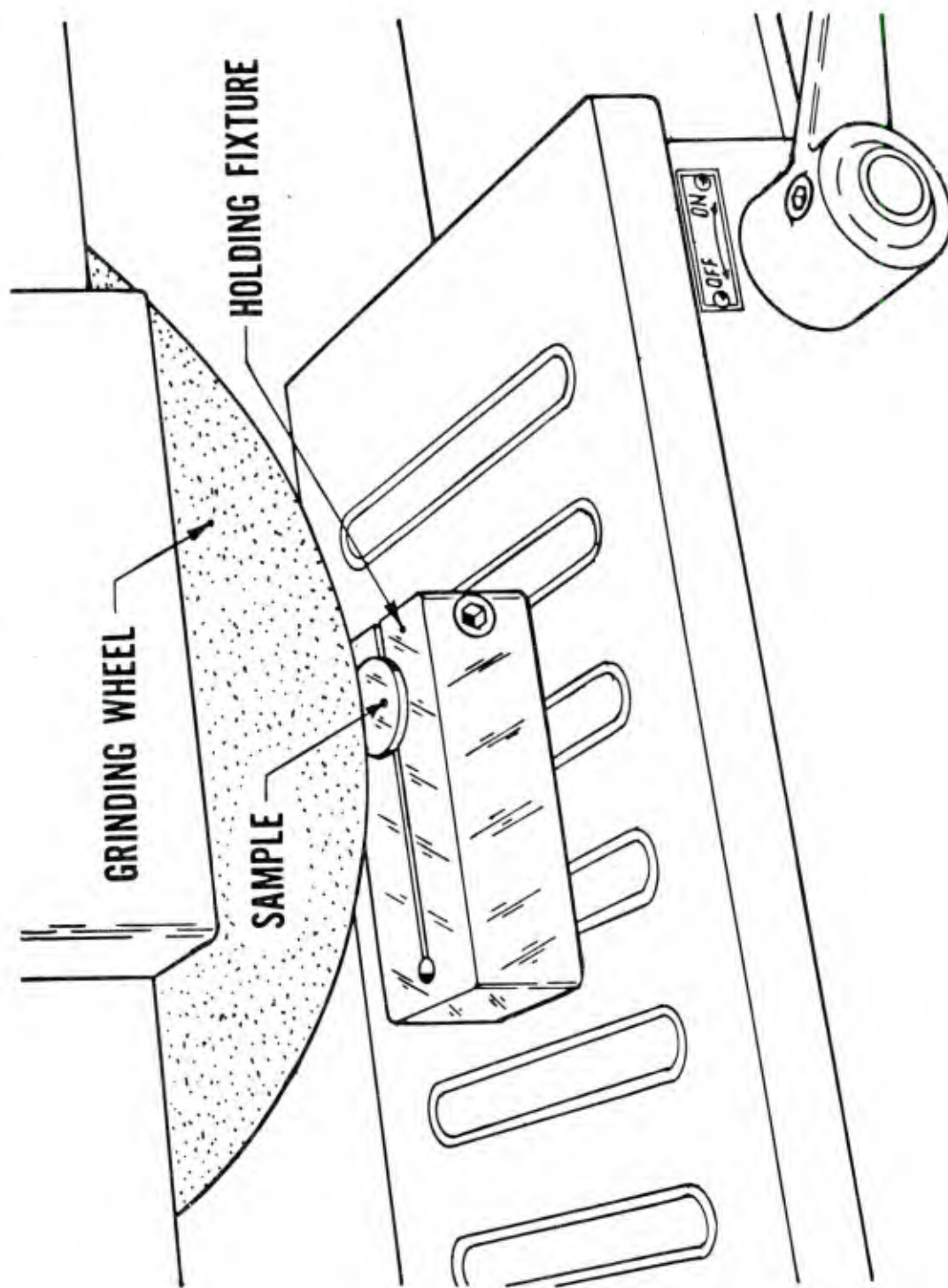

Figure 1. Determining adhesion using the Shaper Groove Test. Surface grinding a superalloy specimen for Chromium plating.

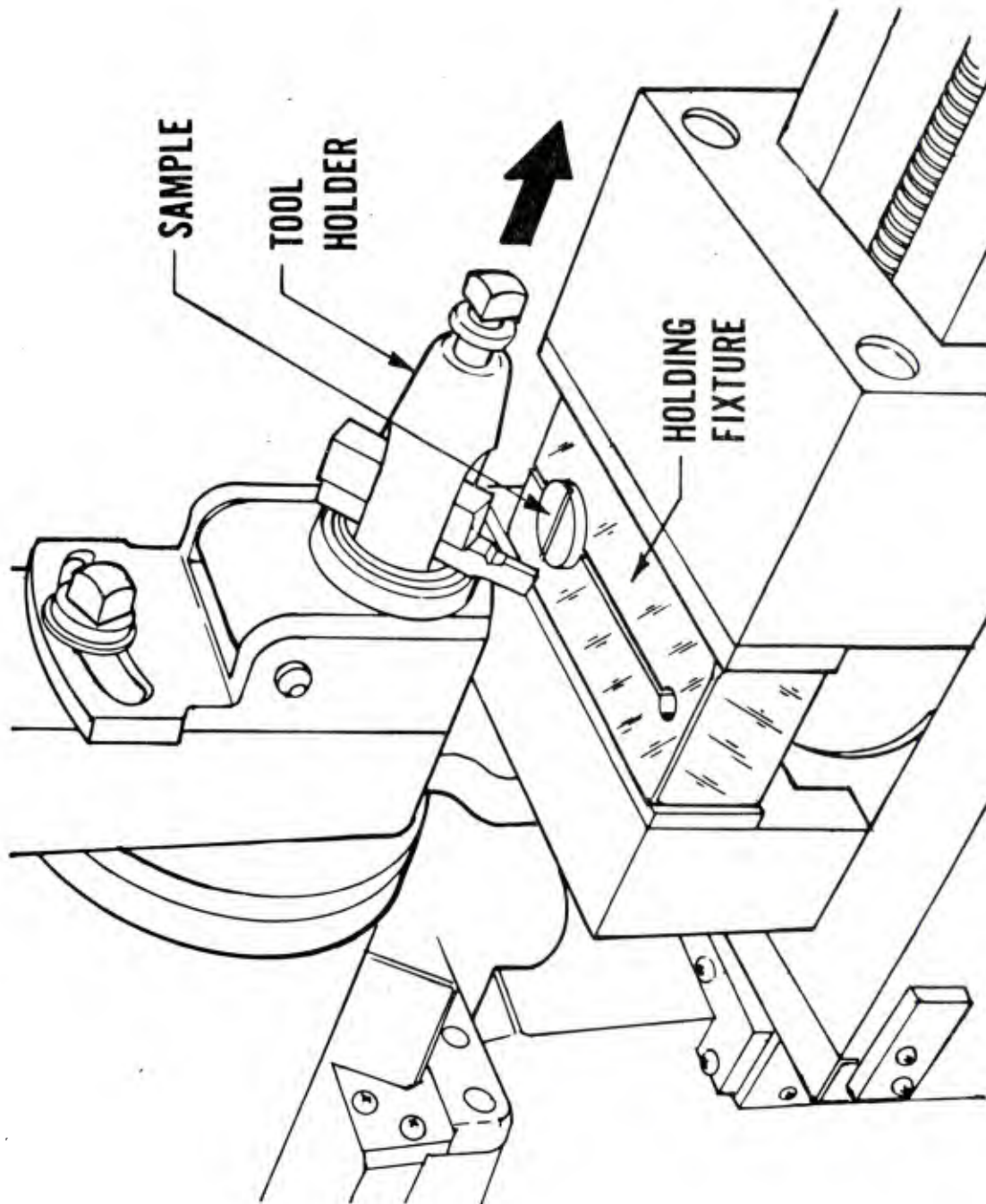
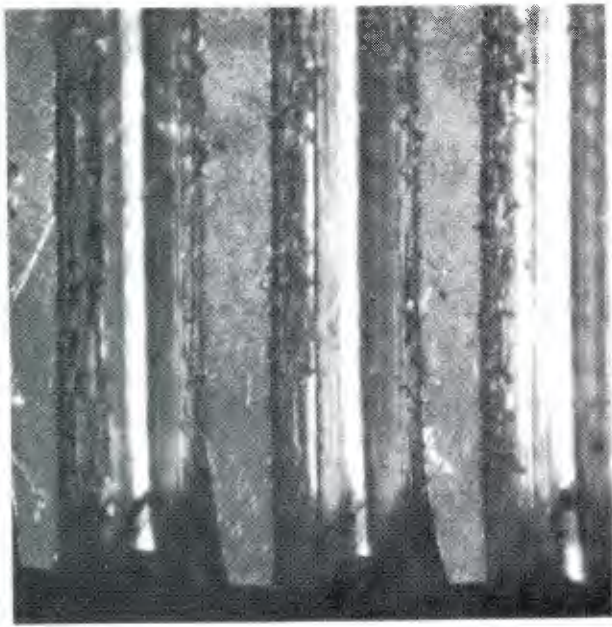
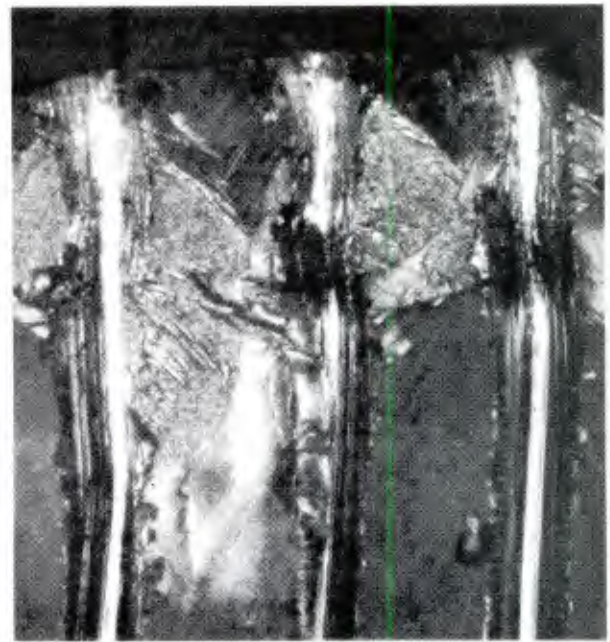

Figure 1a. Adhesion Testing by cutting grooves across a chromium plated specimen.



A



B

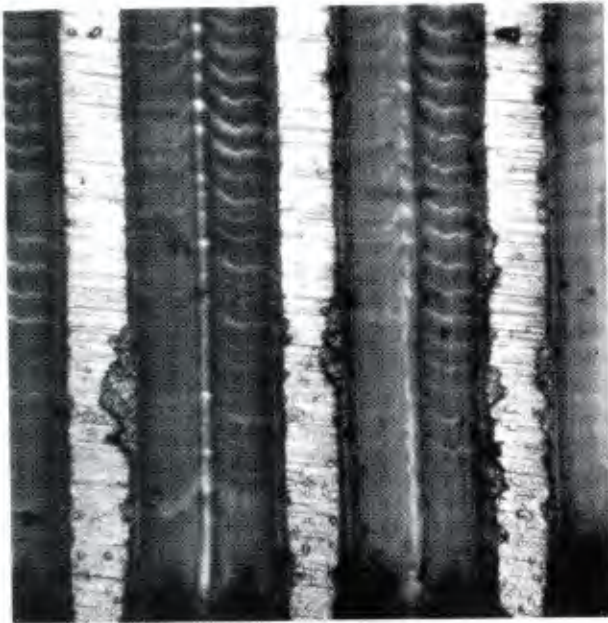

C

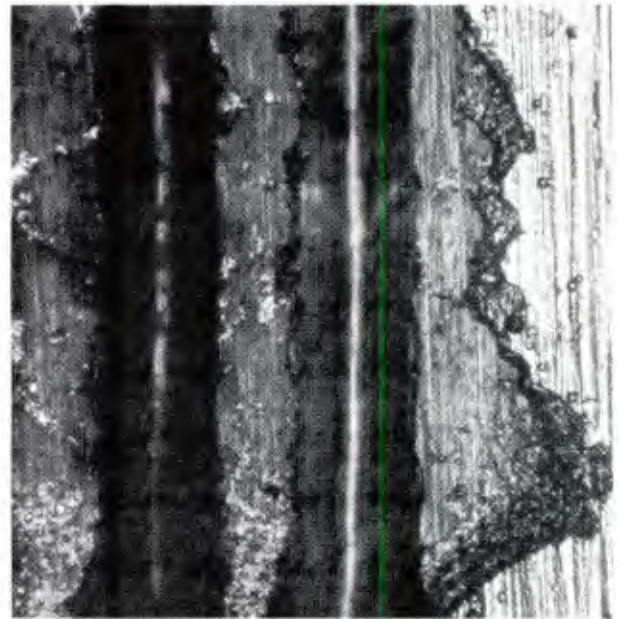

D

Figure 2 Shaper Groove Test of LC Chromium on Gun Steel (A) and (B) and HC Chromium on Gun Steel (C) and (D).

TECHNICAL REPORT INTERNAL DISTRIBUTION LIST

	<u>NO. OF COPIES</u>
COMMANDER	1
CHIEF, DEVELOPMENT ENGINEERING BRANCH	1
ATTN: DRDAR-LCB-DA	1
-DM	1
-DP	1
-DR	1
-DS	1
-DC	1
CHIEF, ENGINEERING SUPPORT BRANCH	1
ATTN: DRDAR-LCB-SE	1
-SA	1
CHIEF, RESEARCH BRANCH	2
ATTN: DRDAR-LCB-RA	1
-RC	1
-RM	1
-RP	1
CHIEF, LWC MORTAR SYS. OFC.	1
ATTN: DRDAR-LCM	1
CHIEF, IMP. 81MM MORTAR OFC.	1
ATTN: DRDAR-LCB-I	1
TECHNICAL LIBRARY	5
ATTN: DRDAR-LCB-TL	
TECHNICAL PUBLICATIONS & EDITING UNIT	2
ATTN: DRDAR-LCB-TL	
DIRECTOR, OPERATIONS DIRECTORATE	1
DIRECTOR, PROCUREMENT DIRECTORATE	1
DIRECTOR, PRODUCE ASSURANCE DIRECTORATE	1

NOTE: PLEASE NOTIFY ASSOC. DIRECTOR, BENET WEAPONS LABORATORY, ATTN:
DRDAR-LCB-TL, OF ANY REQUIRED CHANGES.

TECHNICAL REPORT EXTERNAL DISTRIBUTION LIST

	<u>NO. OF COPIES</u>		<u>NO. OF COPIES</u>
ASST SEC OF THE ARMY RESEARCH & DEVELOPMENT ATTN: DEP FOR SCI & TECH THE PENTAGON WASHINGTON, D.C. 20315	1	COMMANDER US ARMY TANK-AUTMV R&D COMD ATTN: TECH LIB - DRDTA-UL MAT LAB - DRDTA-RK WARREN MICHIGAN 48090	1 1
COMMANDER US ARMY MAT DEV & READ. COMD ATTN: DRCDE 5001 EISENHOWER AVE ALEXANDRIA, VA 22333	1	COMMANDER US MILITARY ACADEMY ATTN: CHMN, MECH ENGR DEPT WEST POINT, NY 10996	1
COMMANDER US ARMY ARRADCOM ATTN: DRDAR-LC -LCA (PLASTICS TECH EVAL CEN) -LCE -LCM -LCS -LCW -TSS(STINFO) DOVER, NJ 07801	1 1 1 1 1 1 2	COMMANDER REDSTONE ARSENAL ATTN: DRSMI-RB -RRS -RSM ALABAMA 35809 COMMANDER ROCK ISLAND ARSENAL ATTN: SARRI-ENM (MAT SCI DIV) ROCK ISLAND, IL 61202	2 1 1 1 1
COMMANDER US ARMY ARRCOM ATTN: DRSAR-LEP-L ROCK ISLAND ARSENAL ROCK ISLAND, IL 61299	1	COMMANDER HQ, US ARMY AVN SCH ATTN: OFC OF THE LIBRARIAN FT RUCKER, ALABAMA 36362	1
DIRECTOR US Army Ballistic Research Laboratory ATTN: DRDAR-TSB-S (STINFO) ABERDEEN PROVING GROUND, MD 21005	1	COMMANDER US ARMY FGN SCIENCE & TECH CEN ATTN: DRXST-SD 220 7TH STREET, N.E. CHARLOTTESVILLE, VA 22901	1
COMMANDER US ARMY ELECTRONICS COMD ATTN: TECH LIB FT MONMOUTH, NJ 07703	1	COMMANDER US ARMY MATERIALS & MECHANICS RESEARCH CENTER ATTN: TECH LIB - DRXMR-PL WATERTOWN, MASS 02172	2
COMMANDER US ARMY MOBILITY EQUIP R&D COMD ATTN: TECH LIB FT BELVOIR, VA 22060			

NOTE: PLEASE NOTIFY COMMANDER, ARRADCOM, ATTN: BENET WEAPONS LABORATORY, DRDAR-LCB-TL, WATERVLIET ARSENAL, WATERVLIET, N.Y. 12189, OF ANY REQUIRED CHANGES.

TECHNICAL REPORT EXTERNAL DISTRIBUTION LIST (CONT)

	<u>NO. OF COPIES</u>		<u>NO. OF COPIES</u>
COMMANDER US ARMY RESEARCH OFFICE P.O. BOX 12211 RESEARCH TRIANGLE PARK, NC 27709	1	COMMANDER DEFENSE TECHNICAL INFO CENTER ATTN: DTIA-TCA CAMERON STATION ALEXANDRIA, VA 22314	12
COMMANDER US ARMY HARRY DIAMOND LAB ATTN: TECH LIB 2800 POWDER MILL ROAD ADELPHIA, MD 20783	1	METALS & CERAMICS INFO CEN BATTELLE COLUMBUS LAB 505 KING AVE COLUMBUS, OHIO 43201	1
DIRECTOR US ARMY INDUSTRIAL BASE ENG ACT ATTN: DRXPE-MT ROCK ISLAND, IL 61201	1	MECHANICAL PROPERTIES DATA CTR BATTELLE COLUMBUS LAB 505 KING AVE COLUMBUS, OHIO 43201	1
CHIEF, MATERIALS BRANCH US ARMY R&S GROUP, EUR BOX 65, FPO N.Y. 09510	1	MATERIEL SYSTEMS ANALYSIS ACTV ATTN: DRXSY-MP ABERDEEN PROVING GROUND MARYLAND 21005	1
COMMANDER NAVAL SURFACE WEAPONS CEN ATTN: CHIEF, MAT SCIENCE DIV DAHLGREN, VA 22448	1		
DIRECTOR US NAVAL RESEARCH LAB ATTN: DIR, MECH DIV CODE 26-27 (DOC LIB) WASHINGTON, D. C. 20375	1 1		
NASA SCIENTIFIC & TECH INFO FAC P. O. BOX 8757, ATTN: ACQ BR BALTIMORE/WASHINGTON INTL AIRPORT MARYLAND 21240	1		

NOTE: PLEASE NOTIFY COMMANDER, ARRADCOM, ATTN: BENET WEAPONS LABORATORY, DRDAR-LCB-TL, WATERVLIET ARSENAL, WATERVLIET, N.Y. 12189, OF ANY REQUIRED CHANGES.