

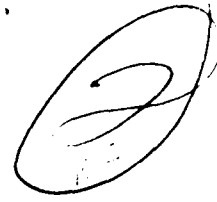

LEVEL



RESEARCH AND DEVELOPMENT TECHNICAL REPORT

DELCS-TR-81-2

AD A104429

A SMALL ELECTRONIC SCAN ANGLE ANTENNA FOR MILLIMETER WAVES

JOHN BOROWICK  
RICHARD A. STERN  
RICHARD W. BABBITT  
COMBAT SURVEILLANCE & TARGET ACQUISITION LABORATORY

SEPTEMBER 1981

DISTRIBUTION STATEMENT  
Approved for public release;  
distribution unlimited.

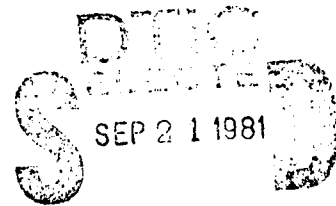

A

ERADCOM

US ARMY ELECTRONICS RESEARCH & DEVELOPMENT COMMAND  
FORT MONMOUTH, NEW JERSEY 07703

81 0 21 03

DTIC FILE COPY

## NOTICES

### **Disclaimers**

The citation of trade names and names of manufacturers in this report is not to be construed as official Government indorsement or approval of commercial products or services referenced herein.

### **Disposition**

Destroy this report when it is no longer needed. Do not return it to the originator.

UNCLASSIFIED

SECURITY CLASSIFICATION OF THIS PAGE (When Data Entered)

REPORT DOCUMENTATION PAGE		READ INSTRUCTIONS BEFORE COMPLETING FORM	
1. REPORT NUMBER 14 DELCS-TR-81-2	2. GOVT ACCESSION NO. AD-A104 429	3. RECIPIENT CATALOG NUMBER	
4. TITLE (and Subtitle) A Small Electronic Scan Angle Antenna For Millimeter Waves		5. TYPE OF REPORT & PERIOD COVERED Technical Report	
		6. PERFORMING ORG. REPORT NUMBER	
7. AUTHOR(s) JOHN BOROWICK; RICHARD A. STERN AND RICHARD W. BABBITT		8. CONTRACT OR GRANT NUMBER(s)	
9. PERFORMING ORGANIZATION NAME AND ADDRESS HQ, US Army Combat Surveillance & Target Acquisition Laboratory ATTN: DELCS-R-T, Fort Monmouth, NJ 07703		10. PROGRAM ELEMENT, PROJECT, TASK AREA & WORK UNIT NUMBERS AMCMS 6.11.01.A Project No. 1L161101A91A	
11. CONTROLLING OFFICE NAME AND ADDRESS HQ, US Army Combat Surveillance & Target Acquisition Laboratory ATTN: DELCS-R-T, Fort Monmouth, NJ 07703		12. REPORT DATE 11 September 1981	
14. MONITORING AGENCY NAME & ADDRESS (if different from Controlling Office)		13. NUMBER OF PAGES	
		15. SECURITY CLASS. (of this report) Unclassified	
		15a. DECLASSIFICATION/DOWNGRADING SCHEDULE	
16. DISTRIBUTION STATEMENT (of this Report) Approved for public release; distribution unlimited.			
17. DISTRIBUTION STATEMENT (of the abstract entered in Block 20, if different from Report)			
18. SUPPLEMENTARY NOTES			
19. KEY WORDS (Continue on reverse side if necessary and identify by block number) Antennas Millimeter Waves Phase Shifters			
20. ABSTRACT (Continue on reverse side if necessary and identify by block number) A millimeter wave feasibility line source array has been designed and constructed as part of an effort to investigate techniques for low cost phase scan at millimeter frequencies. The array is composed of 15 edge slots on a specially constructed waveguide housing assembly containing discrete ferrite toroids. The entire array employs the series ferrite scan technique for simple, low cost scan. A description of the array design and configuration is given. Antenna patterns and the resultant scan characteristics are also presented.			

TABLE OF CONTENTS

	Page
INTRODUCTION	1
ANTENNA CONCEPT	1
DESIGN CONSIDERATIONS	2
PHASE SHIFTER FABRICATION	3
MEASURED DATA	3
CONCLUSIONS	4

LIST OF ILLUSTRATIONS

Figure

1. Series Ferrite Scan Concept	5
2. Phase Shifter Hysteresis Loop	6
3. Arc-Plasma Spray Process	7
4. SFS Toroid - Cross Section	8
5. SFS Toroid - Side View	8
6. Measured Pattern-Empty Housing 34 GHz	9
7. Measured Pattern-Empty Housing 35 GHz	10
8. Measured Pattern-Empty Housing 36 GHz	11
9. Insertion Loss vs. Frequency - SFS Array	12
10. Measured Pattern - SFS Array 31.5 GHz	13
11. Measured Pattern - SFS Array 32.0	14
12. Measured Pattern - SFS Array 32.5	15
13. SFS Characteristics	16
14. Photograph - Completed SFS Array	16

Accession For	
DTIC GRA&I	<input checked="" type="checkbox"/>
DTIC TAB	<input type="checkbox"/>
Unannounced	<input type="checkbox"/>
Justification	

Distribution/	
Availability Codes	
Avail and/or	
Special	

A

## A SMALL ELECTRONIC SCAN ANGLE ANTENNA FOR MILLIMETER WAVES

### INTRODUCTION

A millimeter wave line source feasibility antenna for small electronic scan is described. The line source consists of 15 edge slots located on a specially constructed Ka-band waveguide housing. Arc plasma sprayed ferrite toroids are located internal to the waveguide and centered between each of the slots. Each of the toroids, with its matching transformers, comprises an individual unit cell. A single wire, which serves as the magnetization loop for the entire array, is threaded through all of the ferrite cells. By adjusting either the amplitude or the width of a driver voltage pulse, a differential phase shift is obtained between each of the series-fed slots and electronic scan is accomplished. The amount of angular scan depends on the amount of differential phase shift in the ferrite material. In order to steer a series-fed array, the ferrite must have not only that differential phase for interelement phase shift, but enough to overcome the frequency dispersion of the waveguide, depending on the bandwidth required.

### ANTENNA CONCEPT

The series ferrite scan (SFS) concept is shown in Figure 1. The antenna is a traveling wave edge-slotted array with discrete ferrite phase shifting elements located internal to the waveguide. The array was built in a specially constructed waveguide having inside dimensions identical to that of an RG-96 waveguide. The narrow wall has in it the radiating shunt slots. The discrete phasers are arrayed along the longitudinal axis of the waveguide. Each of the ferrite toroids, with its matching transformers, comprises a unit cell. A single switching wire, which serves as the magnetizing loop for the entire array, is threaded through all the ferrite cells. This single switching wire is used to drive the ferrite material into its various phase states. The line source is, thus, an integral non-reciprocal phase shifter radiator antenna.

The operation of the SFS antenna may be explained by first briefly describing some well known facts about ferrite magnetization. The differential phase shift switching characteristics of a ferrite phase shifter can be seen by referring to Figure 2. The ferrite toroid is magnetized circumferentially by passing a current pulse through the switching wire. A positive saturating current pulse will magnetize the ferrite toroid to the  $+4\pi M_{\max}$  (point a) position of the hysteresis loop of Figure 2. When this current is removed, the ferrite magnetization will fall back along the curve to the position  $+4\pi M_r$  (point b). This point is called the remanent point, or ferrite remanence. Since this ferrite toroid configuration has a nearly square hysteresis loop, it retains a larger part of the magnetization when the current pulse is removed and the ferrite is said to be "latched" at point b. Thus, no further holding current is needed to retain the magnetization at this phase state. By applying a negative saturating current pulse the magnetization can be reversed and thereby the ferrite will be driven into the  $-4\pi M_{\max}$  state at point c. At the end of this negative saturating pulse, the magnetization will follow along the hysteresis curve to the point d. The difference in phase shift between

points b and d determines the amount of useful differential phase shift available from the particular ferrite material. Intermediate magnetization states can be obtained by utilizing appropriate lesser values of current pulses to obtain intermediate values of phase shift. The intermediate values of current pulses will drive the magnetization into minor hysteresis loops within the major hysteresis loop. Since the ferrite toroids are in series, an RF signal propagating through each of the toroids will be changed in phase, and when this RF is coupled through each slot associated with a particular ferrite, the main beam will be radiated in a direction determined by the relative phase shift between those slots.

This ferrite toroid switching action can then be related to the main beam antenna pointing by referring back to Figure 1. Since the line source has its radiating slots in series with the RF signal, the beam will also scan with frequency. For example, Figure 1 shows, in a qualitative way, how, at a fixed ferrite magnetization state, say  $\phi$  min corresponding to  $-4\pi M_r$ , the beam will frequency scan in the angular region  $F_L, \phi$  min to  $F_H, \phi$  min.

If the ferrite is now switched to  $\phi$  max corresponding to  $+4\pi M_r$ , the beam will frequency scan in the region  $F_L, \phi$  max to  $F_H, \phi$  max. The electronic phase scan region is therefore in the hatched region denoted as field of view, the amount of angular scan being determined by the amount of differential phase shift available from the ferrite material.

#### DESIGN CONSIDERATIONS

The SFS antenna was first built in an unloaded RG-96 aluminum waveguide housing with a removable 0.005" thick removable brass shim stock edge wall. The inner waveguide dimensions are those of a standard RG-96 waveguide. This size waveguide was used so as to operate in the region where the phase dispersion is less, i.e., far away from cutoff, and yet retain the use of standard mating flanges for connection of the housing to both the signal source and RF load. With a frequency scan antenna, phase sensitivity might be desirable and operation near cutoff advantageous, but with the SFS antenna, it is required to minimize this frequency sensitivity. The reason for this is that as the differential phase shift between slots changes with frequency, this phase shift must be compensated for with the differential phase shift of the ferrite, and this is detrimental as there must be additional phase shift available for beam scan.

The removable edge wall was both convenient and necessary for the SFS array. It was convenient in that different slot parameters could easily be implemented, and necessary in that it permits insertion of the ferrite toroids and matching transformers. The edge wall slot radiates by nature of its interrupting the surface currents on the internal wall of the waveguide. The angle of the slot determines the amount of coupling, and so one can design an array of slots for a specified amplitude distribution and, therefore a desired antenna sidelobe level. For this design, all slots were cut at the same angle; therefore, each slot has the same conductance and the resulting amplitude taper across the array is exponential. The exponential taper gives rise to an antenna pattern approximating that of a uniform amplitude distribution.

The phasers in the SFS antenna are each latching, non-reciprocal ferrite toroids, and each toroid is loaded with a high permittivity dielectric core. Loading is used to bring the RF field within the region of the ferrite toroid and permits more differential phase per unit length than if it were unloaded. Dielectric transformers are located on either side of each ferrite toroid to serve as impedance matching devices between the unloaded and loaded waveguide sections.

#### PHASE SHIFTER FABRICATION

The ferrite toroids are fabricated by means of the arc plasma spray (APS) process. The APS process is seen to be the means through which future ferrite phase shifters will be fabricated for millimeter wave applications. The APS deposition of ferrite around a dielectric slab results in a simple and economical process for the production of phasers. This process yields a bonded ferrite/dielectric interface which is necessary for optimum performance. In operation, the arc plasma spray gun melts the ferrite powder and projects it onto the target (i.e., the dielectric core) as shown in the schematic of Figure 3. In commercial phaser fabrication, the dielectric core is inserted into the ferrite toroid, and unavoidable air gaps often result in inadequate device performance. The APS process produces a phaser from the inside out in less than two minutes. The technique for forming the hole to accommodate the switching wire in the toroid was to epoxy bond a strip of carbon or boron nitride to the edge of the dielectric loading material. This combination of materials remains intact during the APS procedure but the carbon or boron nitride sublimates out during the high temperature ferrite anneal cycle, thereby leaving a hole for the switching wire. The resultant ferrite magnetic properties are thus achieved by the proper combination of the initial ferrite material composition, the arc plasma spray parameters, and the subsequent ferrite anneal cycle.

The basic phase shifter cross section is shown in Figure 4. The ferrite material used was Trans-Tech pre-calcined lithium ferrite powder (TT-4100) which was subsequently arc plasma sprayed onto the core ( $\epsilon=26$ ). A side view of a single phase shifter cell is shown in Figure 5. Trans-Tech D-4 dielectric material ( $\epsilon=4.3$ ) was used in the design and fabrication of the matching transformers.

#### MEASURED DATA

The line source antenna was first made in the unloaded waveguide housing with 16 alternating edge slots, each having a 17.5 degree tilt angle and spaced 0.211" apart. The nature of the waveguide housing assembly required that the slots be entirely within the removable edge wall. This design was found to be satisfactory as determined from the antenna patterns and gain measurements. Figures 6, 7 and 8 show the measured antenna patterns for the empty waveguide housing (without ferrites) at 34, 35 and 36 GHz, respectively. Gain at these frequencies was measured to be 16 dB, which is as expected.

A toroid and matching transformer unit cell was then measured in waveguide housing but without the radiating slots in the edge wall. The insertion loss was found to be 0.4 dB, which includes the effects due to

imperfections at the interface between the housing and a standard RG-96 flange to the signal source. Each additional phase shifter cell contributes 0.2 dB of loss due to both insertion and reflection loss. When the toroids were cemented into place within the housing, having the slots at 0.211" spacing, the antenna patterns were unsatisfactory in the 35 GHz region. The problems were determined to be due to the proximity of the dielectric matching transformer and the radiating slots. There was a partial blockage by the slot of the internal dielectric, thus, presenting an inhomogeneous environment to the slot. When another edge wall was made with slot separation increased to 0.240", thereby allowing a larger ferrite cell separation, and the number of slots reduced to 15, reasonable antenna patterns were obtained in the 31.5 - 32.5 GHz region. Just outside this frequency band there were occurrences of large insertion loss of several dB as shown in Figure 9. A significant factor in the fabrication of phase shifters at millimeter wave frequencies is the occurrence of these insertion loss regions at unpredictable frequencies. It is anticipated that by using reduced height waveguide, these random insertion loss spikes due to higher order waveguide moding would be better controlled.

Measured SFS antenna patterns for 31.5, 32 and 32.5 GHz are shown in Figures 10, 11 and 12, respectively. Each pattern plot shows the two extreme beam pointing positions, or high and low phase states. The pattern at 32.5 GHz shows the appearance of two high lobes on the opposite side of broadside from the desired main beam. The two closer lobes at each phase state appear to be due to reflections from the load being re-radiated at an angle opposite that of the main beam. The farther out lobe is a grating lobe which is to be expected at this frequency and slot spacing.

Figure 13 shows the summary SFS antenna scan angle characteristics. Each of the two lines indicated by high phase state and low phase state represents the position of the main beam peak with respect to the broadside direction of the array as a function of frequency, as is representative of a frequency scan antenna. At any single frequency, one can phase scan over a 10 degree angle. Over a 500 MHz bandwidth, one can phase scan over a 5 degree sector such as that in the hatched region indicated as field of view. One could also scan over a 20 degree angle with the combination of frequency and phase scan. Discrete beam positions between these low and high phase states can be realized by the control of the amplitude or the phase of the driver current pulse. A photograph of the completed SFS antenna is shown on Figure 14.

#### CONCLUSIONS

This SFS technique is best suited for arrays requiring a small amount of electronic scan. The limitations on RF losses can be offset by sub-arraying small lengths such as that described in this report. The technique is seen to provide a significant savings in cost, weight and size in fulfilling the need for simple functional antennas for small angle electronic scan radars. A fundamental limitation on the amount of phase scan angle possible is the remanent magnetization of the ferrite material.

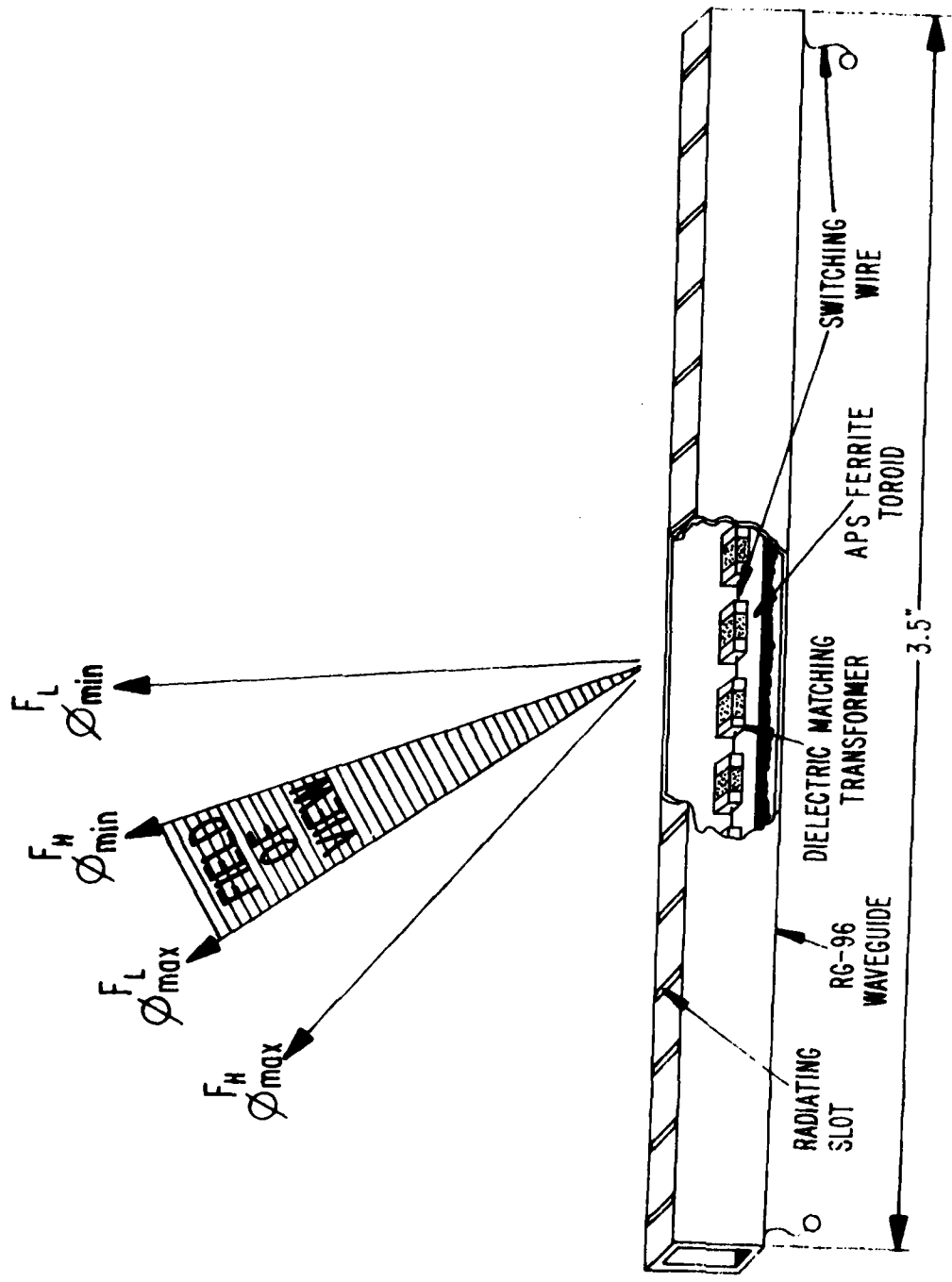

Figure 1. Series Ferrite Scan Concept

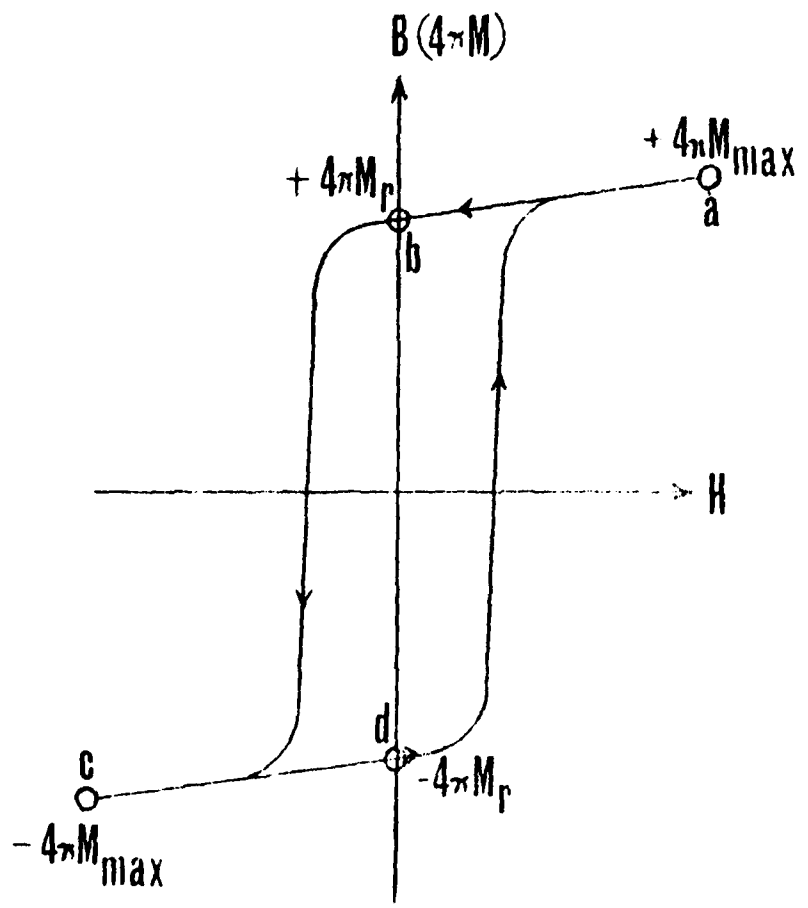

Figure 2. Phase Shifter Hysteresis Loop

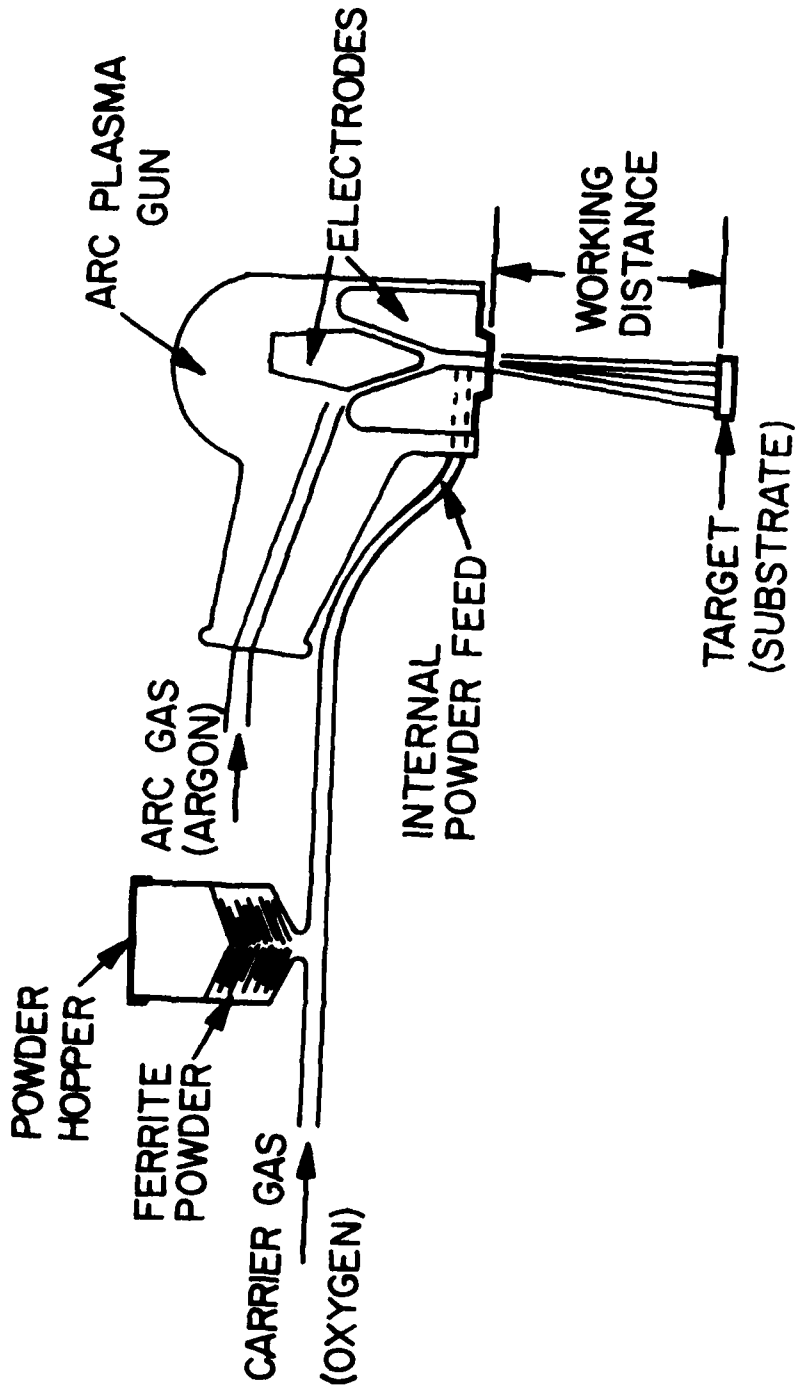

Figure 3. Arc-Plasma Spray Process

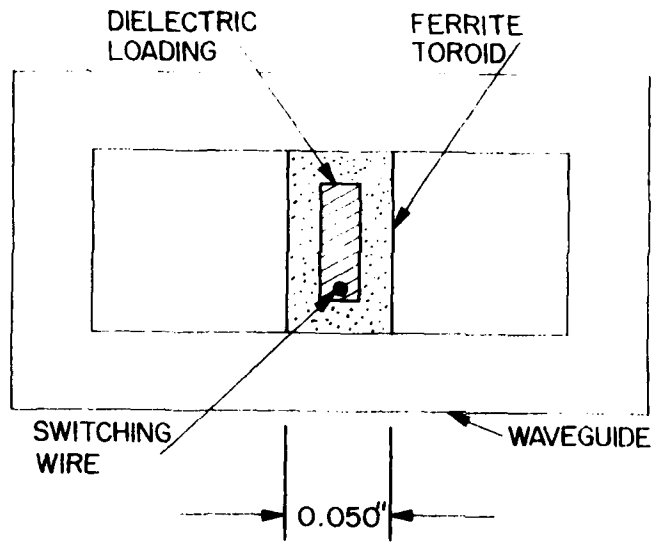

Figure 4. SFS Toroid - Cross Section

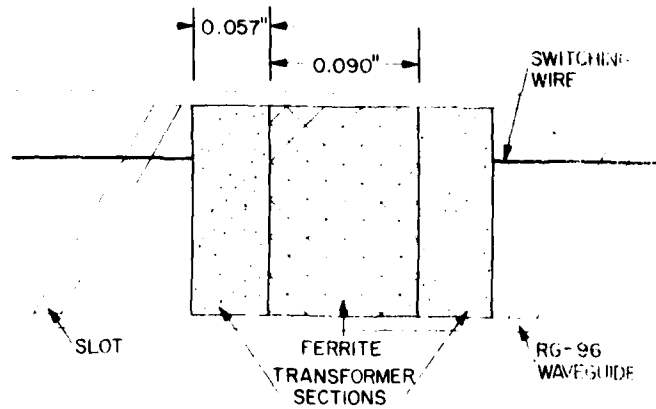

Figure 5. SFS Toroid - Side View

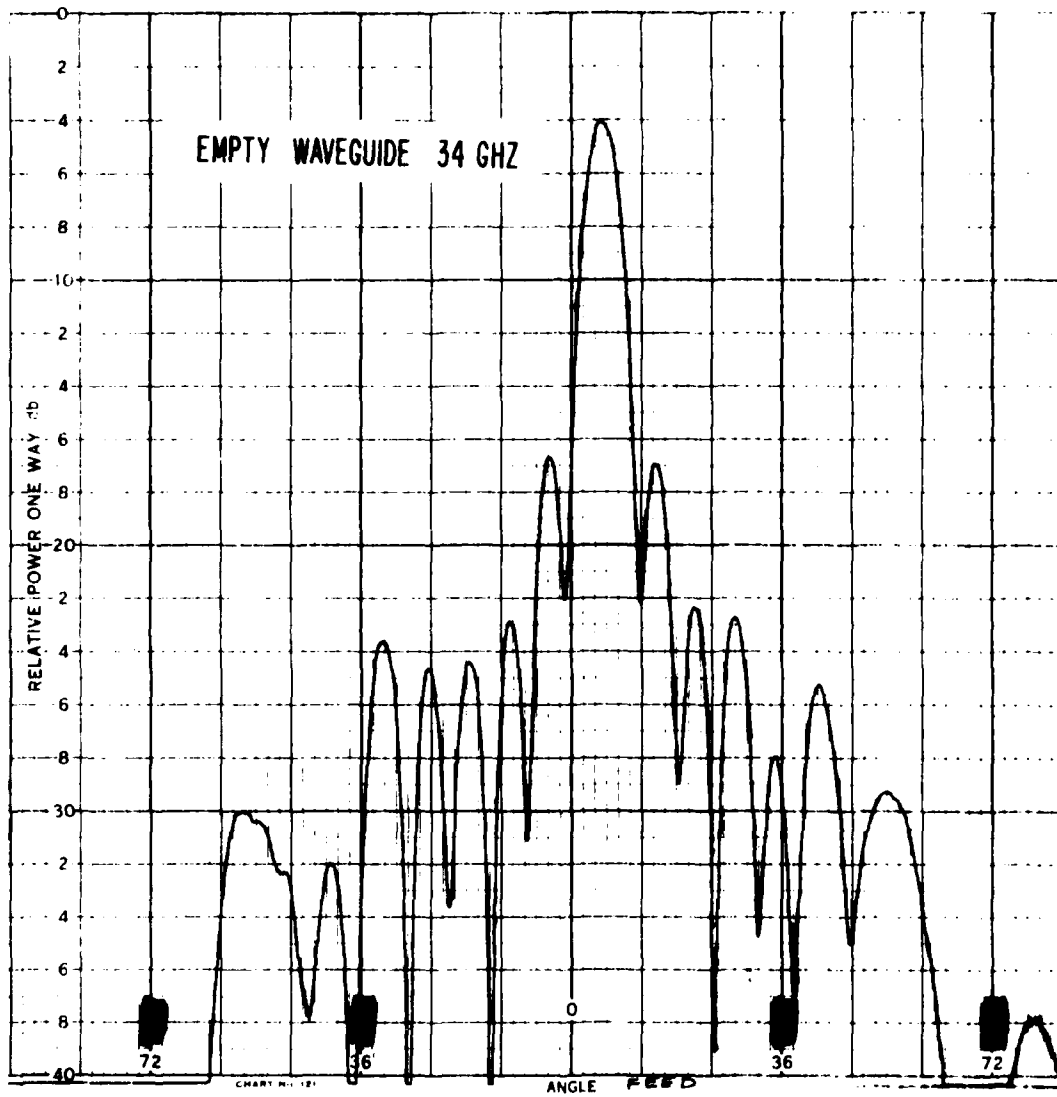

Figure 6. Measured Pattern-Empty Housing 34 GHz

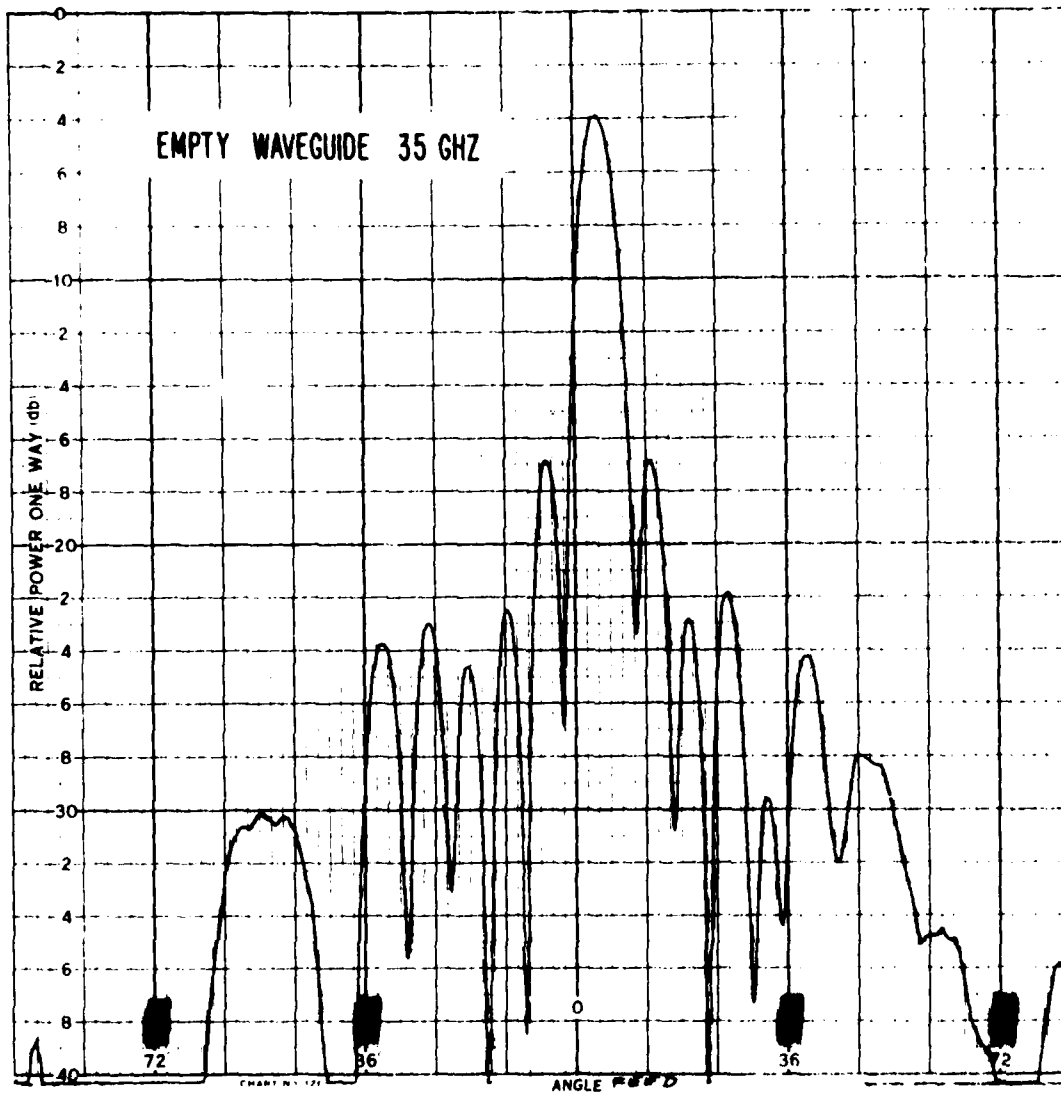

Figure 7. Measured Pattern-Empty Housing 35 GHz

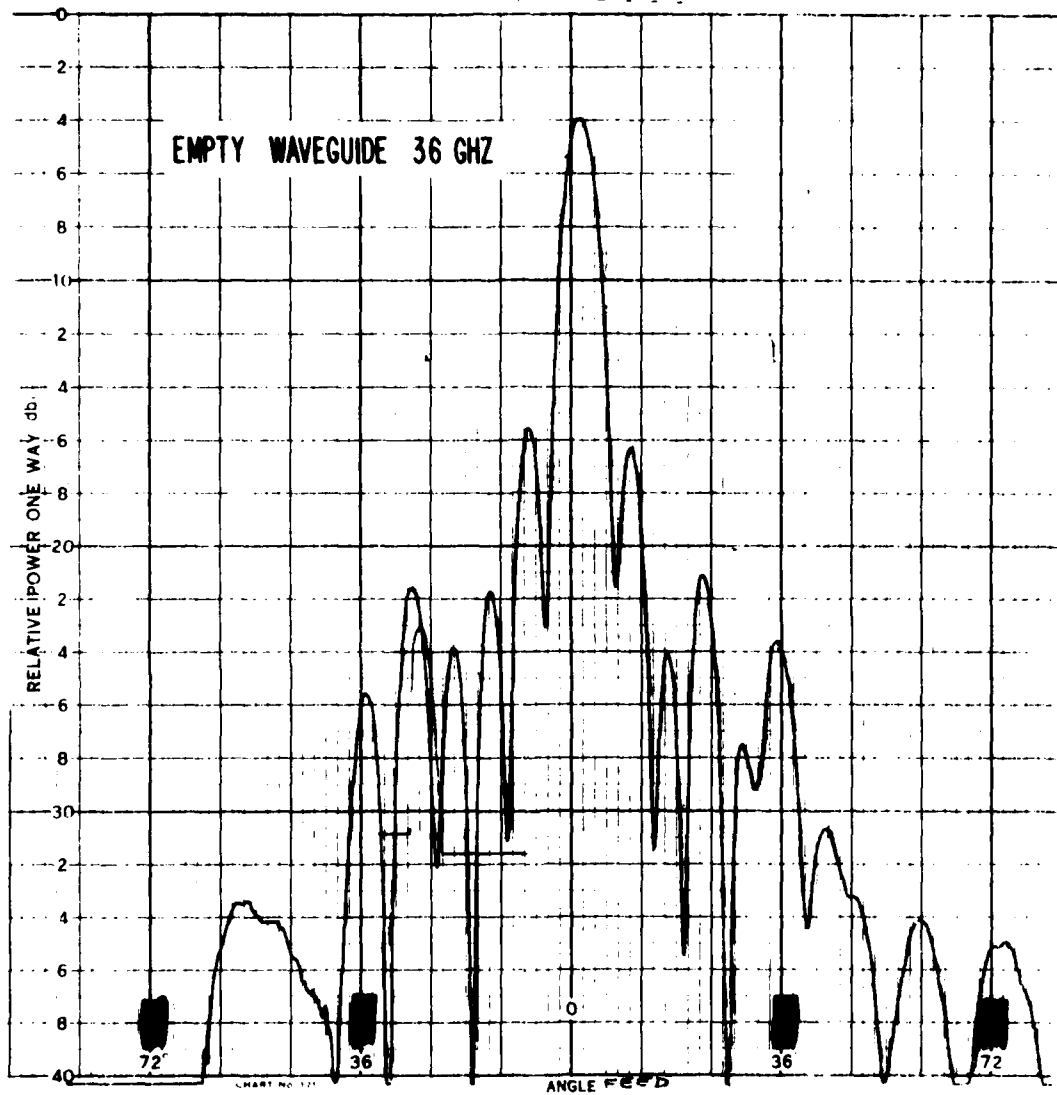

Figure 8. Measured Pattern-Empty Housing 36 GHz

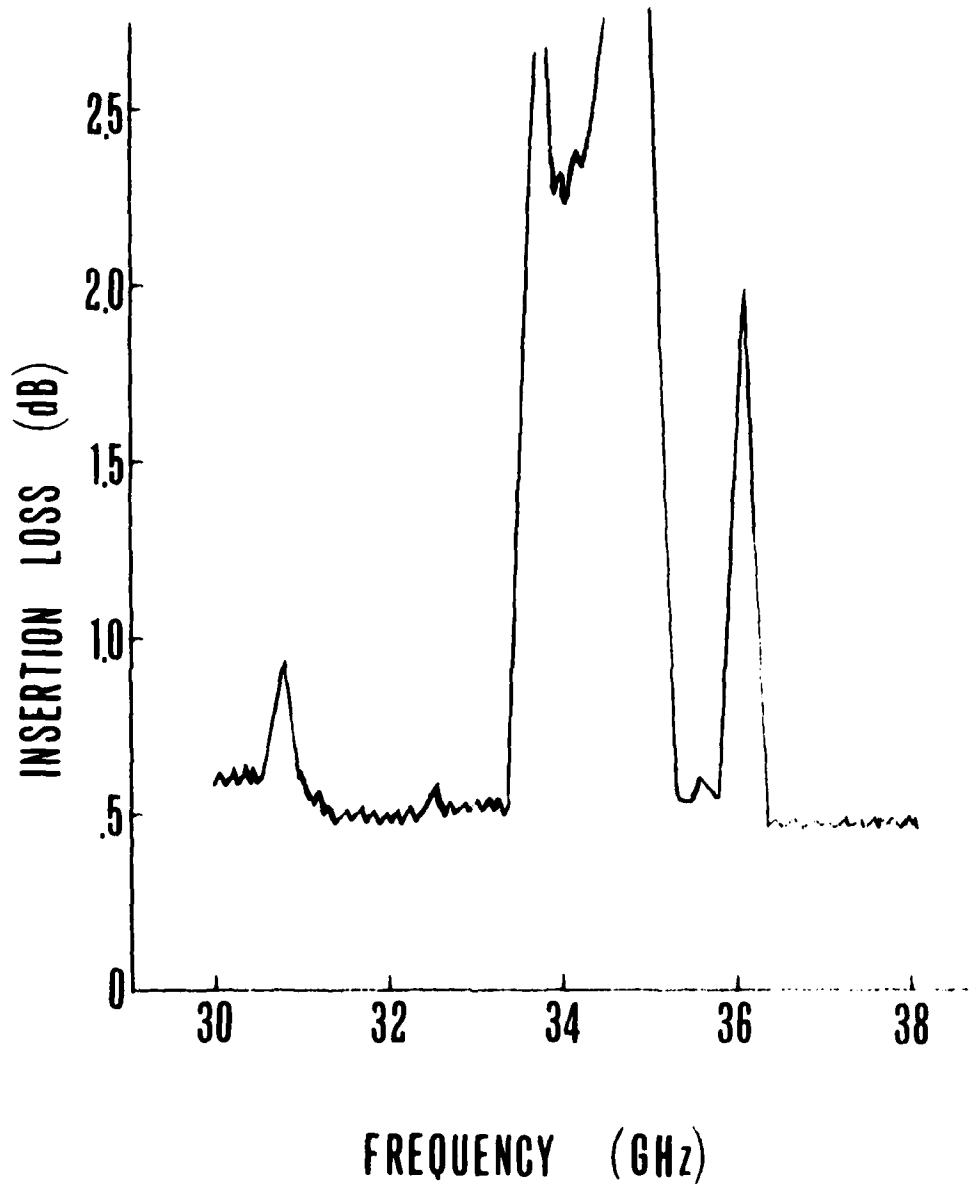

Figure 9. Insertion Loss vs. Frequency - GFS Array

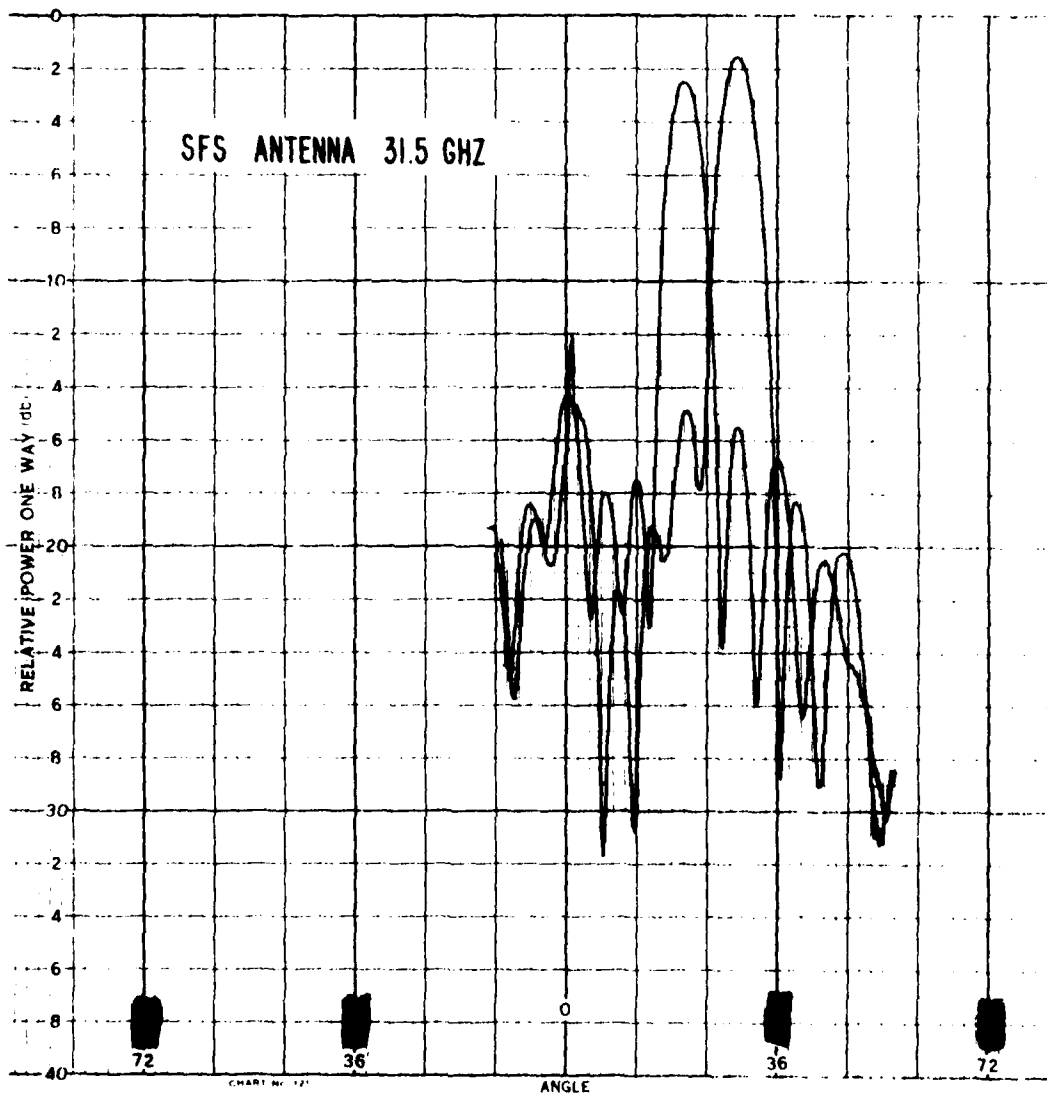

Figure 10. Measured Pattern - SFS Array 31.5 GHz

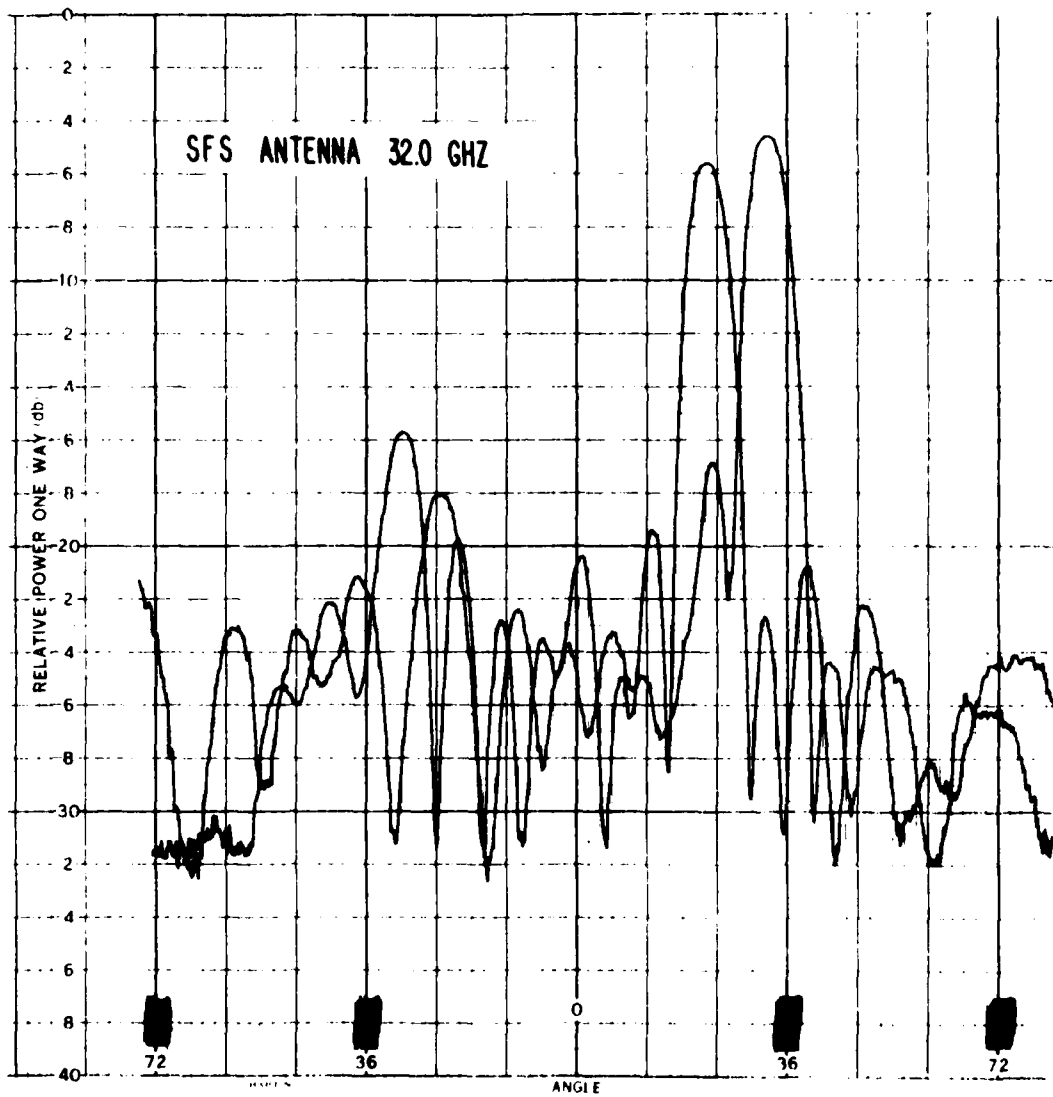

Figure 11. Measured Pattern - SFS Array 32.0 GHz

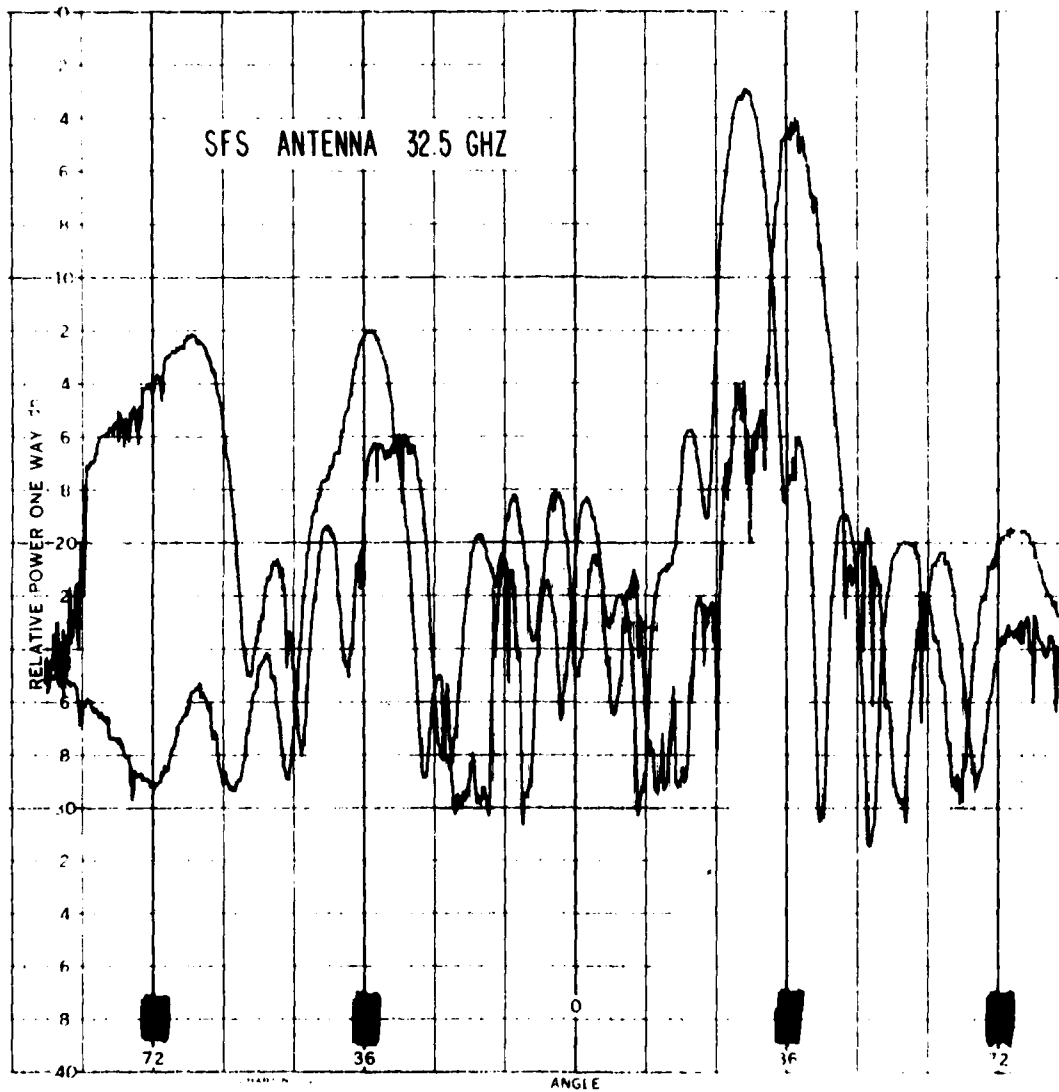

Figure 12. Measured Pattern - SFS Array 32.5 GHz

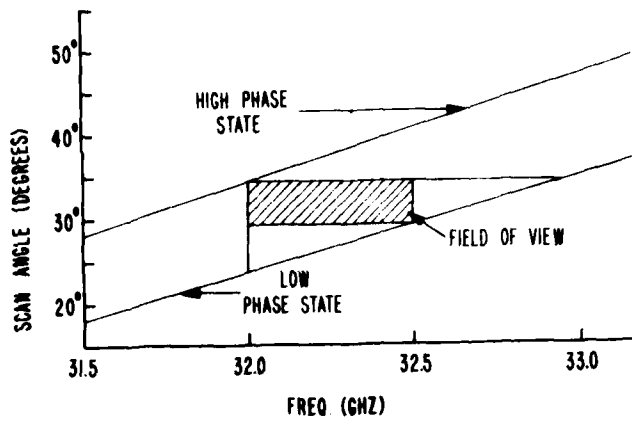

Figure 13. SFS Characteristics

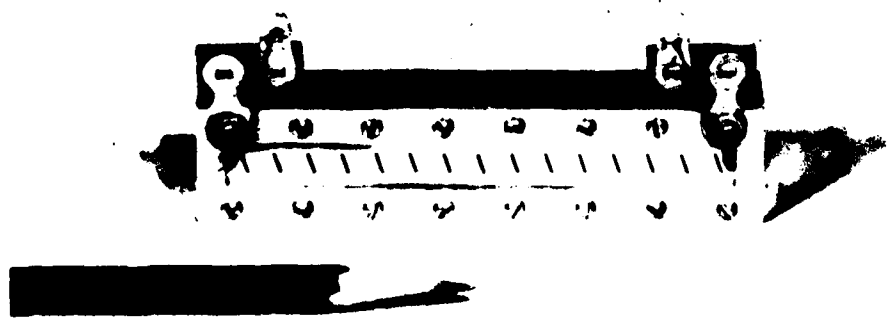

Figure 14. Photograph - Completed SFS Array