

AD-A104 536

NAVAL OCEAN SYSTEMS CENTER SAN DIEGO CA

F/G 17/2

EFFECTS OF POSTDETECTION ON SNR IN OPTICAL COMMUNICATIONS. HOW --ETC(U)

JUN 81 R R JAMES

UNCLASSIFIED

NOSC/TR-699

NL

1 of 1
AS 2
10 25 81

NOSC

END
DATE
FILMED
10-81
DTIC

12

NOSC

NOSC TR 699

NOSC TR 699

Technical Report 699

EFFECTS OF POSTDETECTION ON SNR IN OPTICAL COMMUNICATIONS

How various types of postdetection affect the
performance of the direct-detection
optical receiver

RR James

11 June 1981

Interim Report for FY81

Prepared for
Defense Advanced Research Projects Agency
Arlington VA 22209

Approved for public release; distribution unlimited

NAVAL OCEAN SYSTEMS CENTER
SAN DIEGO, CALIFORNIA 92152

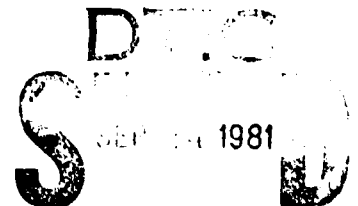

AD A104536

DTIC FILE COPY

81 9 24 004

D



NAVAL OCEAN SYSTEMS CENTER, SAN DIEGO, CA 92152

A N A C T I V I T Y O F T H E N A V A L M A T E R I A L C O M M A N D

SL GUILLE, CAPT, USN

Commander

HL BLOOD

Technical Director

ADMINISTRATIVE INFORMATION

Work was performed under RDDA, DARPA (NOSC 813-CM06) by a member of the Rf and Acoustic Communications Technology Branch (Code 8112) for the Defense Advanced Research Projects Agency. This report covers work for FY81 and was approved for publication 11 June 1981.

Released by
MS Kvigne, Head
Communications Research and
Technology Division

Under authority of
HD Smith, Head
Communications Systems and
Technology Department

UNCLASSIFIED

SECURITY CLASSIFICATION OF THIS PAGE (When Data Entered)

REPORT DOCUMENTATION PAGE		READ INSTRUCTIONS BEFORE COMPLETING FORM
1. REPORT NUMBER NOSC Technical Report 699 (TR 699) ✓	2. GOVT ACCESSION NO. AD-A104 536	3. RECIPIENT'S CATALOG NUMBER
4. TITLE (and Subtitle) EFFECTS OF POSTDETECTION ON SNR IN OPTICAL COMMUNICATIONS How various types of postdetection affect the performance of the direct-detection optical receiver	5. TYPE OF REPORT & PERIOD COVERED Interim FY81	
	6. PERFORMING ORG. REPORT NUMBER	
7. AUTHOR(s) RR James	8. CONTRACT OR GRANT NUMBER(s)	
9. PERFORMING ORGANIZATION NAME AND ADDRESS Naval Ocean Systems Center San Diego, CA 92152	10. PROGRAM ELEMENT, PROJECT, TASK AREA & WORK UNIT NUMBERS RDDA, DARPA (NOSC 813-CM06)	
11. CONTROLLING OFFICE NAME AND ADDRESS Defense Advanced Research Projects Agency Arlington, VA 22209	12. REPORT DATE 11 June 1981	
	13. NUMBER OF PAGES 22	
14. MONITORING AGENCY NAME & ADDRESS (if different from Controlling Office)	15. SECURITY CLASS. (of this report) Unclassified	
	15a. DECLASSIFICATION/DOWNGRADING SCHEDULE	
16. DISTRIBUTION STATEMENT (of this Report) Approved for public release; distribution unlimited		
17. DISTRIBUTION STATEMENT (of the abstract entered in Block 20, if different from Report)		
18. SUPPLEMENTARY NOTES		
19. KEY WORDS (Continue on reverse side if necessary and identify by block number) Optical communications Postdetection filters Laser communications Postdetection processing Optical detection Direct-detection optical receivers Optical receivers Noncoherent optical receivers Satellite-to-underwater communications		
20. ABSTRACT (Continue on reverse side if necessary and identify by block number) ✓ The received SNR of the direct-detection optical receiver is derived. Various types of postdetection are examined and their effects on the received SNR are determined.		

DD FORM 1 JAN 73 1473

EDITION OF 1 NOV 65 IS OBSOLETE
S/N 0102-LF-014-6601

UNCLASSIFIED

SECURITY CLASSIFICATION OF THIS PAGE (When Data Entered)

11/11/81

OBJECTIVE

Derive the received SNR for an optical communication system. Study the effects of postdetection filtering on the received SNR. Evaluate three types of postdetection filters – integrator, matched filter, and low-pass filter – by examining the postdetection effect, which characterizes the SNR degradation due to postdetection processing.

RESULTS

$$1. \text{SNR} = \left(\frac{D}{q} \right) \left(\frac{E_R^2}{P_B} \right) \left(\frac{P_D}{t_m} \right),$$

where

- D = responsivity
- q = electron charge
- E_R = received signal energy
- P_B = background noise power
- t_m = time for pulse to peak
- P_D = postdetection effect

$$= \frac{t_m [s(t) * h(t)]^2}{\int |H(j\omega)|^2 \frac{d\omega}{2\pi}}$$

2. Assuming perfect knowledge of both the pulse arrival time and the received pulse shape, the minimum amount of loss in the received SNR due to the postdetection filters for background-limited noise conditions is 6.58 dB for the optimum integrator, 6 dB for the matched filter, and 7.8 dB for the low-pass filter.

Accession For	
NTIS GRA&I	<input checked="" type="checkbox"/>
DTIC TAB	<input type="checkbox"/>
Unannounced	<input type="checkbox"/>
Justification	
By _____	
Distribution/	
Availability Codes	
Dist	Avail and/or Special
A	

DTIC
SELECTED
 SEP 1981
D

1911

CONTENTS

INTRODUCTION . . .	page 5
System configuration . . .	5
Optical receiver . . .	5
RECEIVED SNR DERIVATION . . .	7
POSTDETECTION EFFECTS . . .	11
Integrator . . .	11
Matched filter . . .	14
RC low-pass filter . . .	15
SUMMARY . . .	21
BIBLIOGRAPHY . . .	21

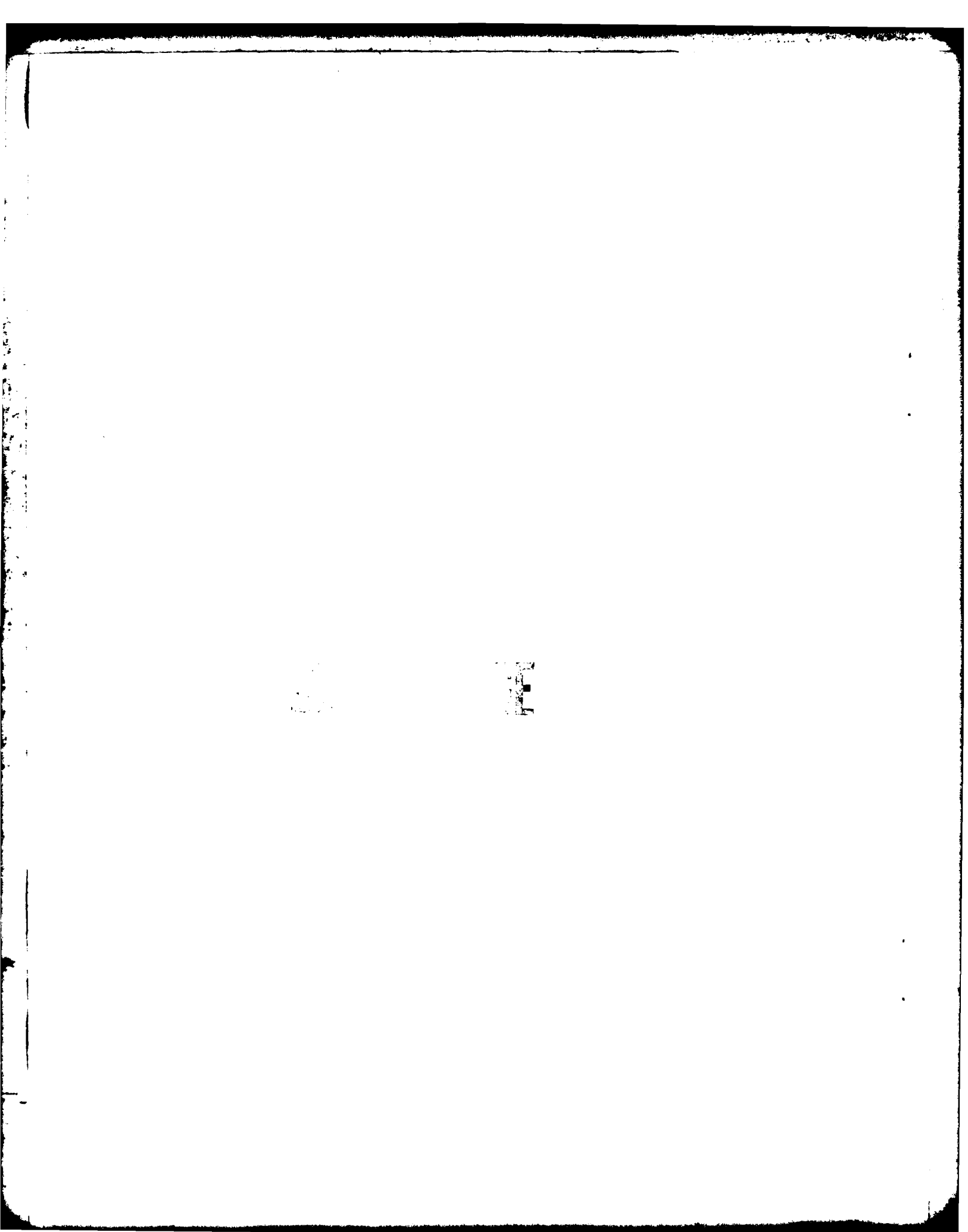

INTRODUCTION

In analyzing a communication system, one is often interested in analytically measuring the performance of the system. One usual measure of performance is the received signal-to-noise ratio (SNR). This paper is concerned with deriving the received SNR for an optical communication system. Particular attention is given to the effects of postdetection filtering on the received SNR. Three types of postdetection filters—integrator, matched filter, and low-pass filter—are evaluated by examining the postdetection effect (P_D), which characterizes the SNR degradation due to postdetection processing. The first step in deriving the optical communication SNR is to define the system configuration and the particular optical receiver to be used.

SYSTEM CONFIGURATION

The optical system of interest is shown in figure 1.

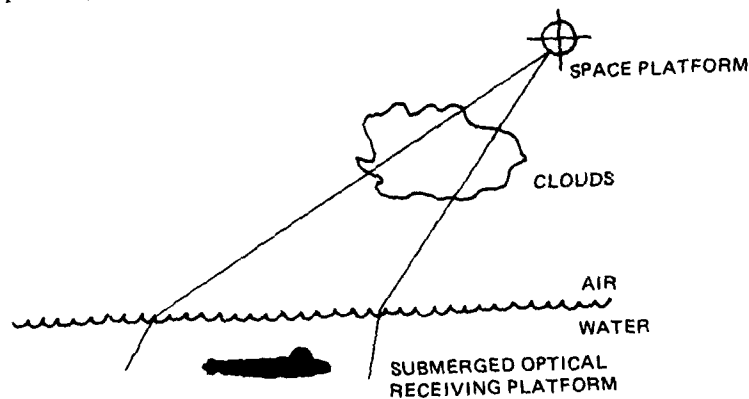

Figure 1. Configuration of the optical communication system.

A spaceborne optical source sends pulses of blue-green light, which travel through clouds and water to a submerged optical receiving platform.

OPTICAL RECEIVER

The optical receiver collects the light from the space platform after it traverses the optical channel and processes it so as to recover the transmitted information. The typical optical receiver is represented by figure 2.

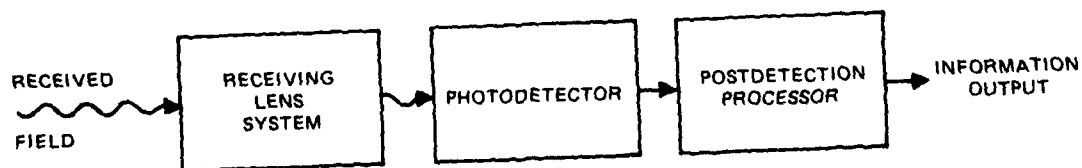

Figure 2. The optical receiver.

A received field is applied to the receiving lens system, where the system lens filters and focuses the received field onto a photodetector. The photodetector converts the optical signal into an electronic signal, and the postdetection processor amplifies and filters this signal for recovery of the desired information.

There are two types of optical receivers: the heterodyne-detection receiver and the direct-detection receiver. These receivers differ in their lens system configurations.

The heterodyne-detection receiver (fig 3) generates a local optical field, which is electromagnetically mixed with the received field through a front-end mirror. The mixed wave is then detected at the photodetector. This receiver is used for amplitude-modulated (AM), frequency-modulated (FM), and phase-modulated (PM) systems. It can be called a spatially coherent receiver since it requires close tolerances on the spatial coherence of the two optical fields.

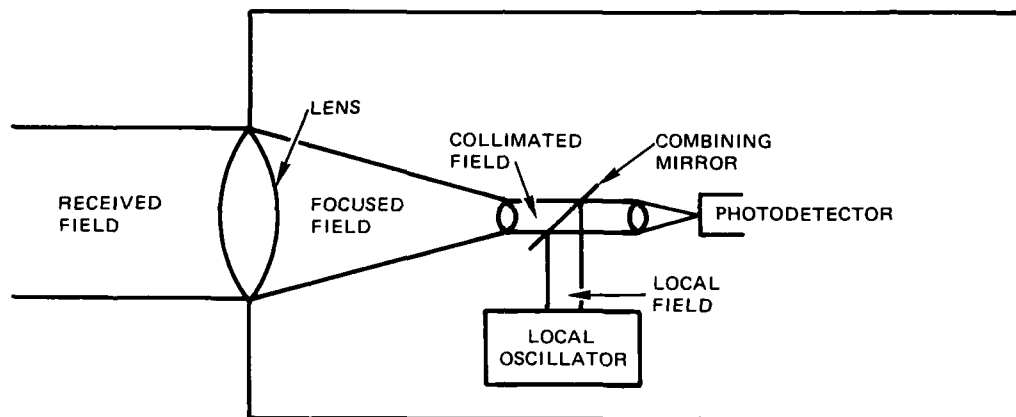

Figure 3. Heterodyne-detection receiver.

The heterodyne-detection receiver is not feasible for the system configuration shown in figure 1 because (1) the spatial coherence of the wave transmitted from the space platform is lost during transit through the propagation medium (clouds and water) and (2) the optical heterodyne receiver antenna theorem (ref 1)

$$A_R \Omega_R \leq \lambda^2, \quad (1)$$

where

A_R = receiver area

Ω_R = receiver solid angle

λ = transmitted wavelength,

cannot be reasonably met.

The direct-detection receiver or noncoherent receiver (fig 4) is a power-detecting device. After travelling through the optical lens, the received field is focused onto the photodetector, which detects the instantaneous power in the collected field. Filtering added ahead of the photodetector permits spatial and frequency discrimination to be used against undesired background radiation. Spatial discrimination can be provided by a polarization filter; frequency discrimination, by an optical bandpass filter.

1. The Antenna Properties of Orbital Heterodyne Receivers, by AE Siegman; App Opt, vol 5, p 1588-1594, 1966.

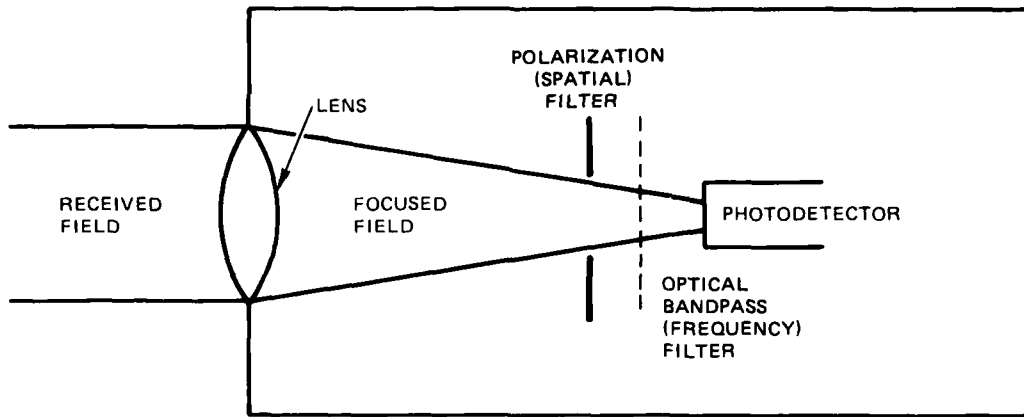

Figure 4. Direct-detection receiver.

RECEIVED SNR DERIVATION

The direct-detection receiver can be expanded into an electrical signal model (fig 5A), with a generalized optical receiver for comparison (fig 5B). The output current of the photodetector is proportional to the instantaneous received power, which (for this system configuration) is of the form

$$i_p \propto p(t) = te^{-t/t_m} \quad (2)$$

The instantaneous received power as seen at the photodetector is as follows:

$$\begin{aligned} P_R(t) &= \frac{E_R p(t)}{\int p(t) dt} \\ &= E_R s(t) \end{aligned} \quad (3)$$

where

$$\begin{aligned} E_R &= \text{total received signal energy} \\ p(t) &= te^{-t/t_m} u(t) \\ u(t) &= \begin{cases} 0 & t < 0 \\ 1 & t \geq 0 \end{cases} \\ \int p(t) dt &= t_m^2 \\ s(t) &= p(t) / \int p(t) dt \\ t_m &= \text{time at which the peak value of the pulse occurs.} \end{aligned}$$

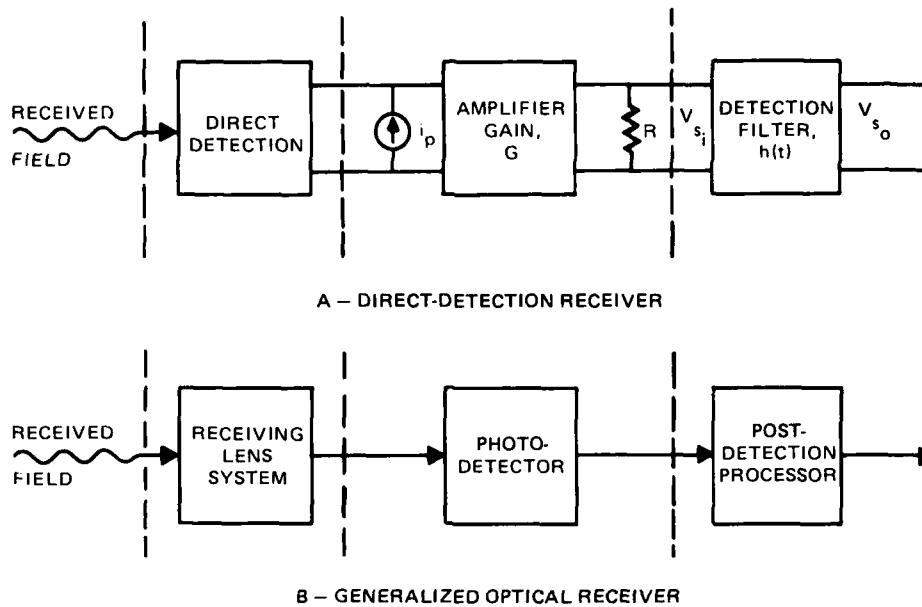

Figure 5. Electrical signal model of the direct-detection receiver.

The photodetector current is related to the instantaneous received power by the equation

$$i_p = D P_R(t) , \quad (4)$$

where

$$D = \frac{\xi \lambda}{hc} q \quad (5)$$

and

D = receiver responsivity (A/W)

ξ = photodetector efficiency

λ = optical wavelength (m)

q = electron charge (A·s)

h = Planck's constant ($W \cdot s^2$)

c = speed of light (m/s)

By means of the electric signal model in figure 5 and equation (4), the optical receiver performance parameter (the postdetection filter output SNR) can now be determined. The input and output signal voltages appearing at the detector filter are as follows:

$$\begin{aligned} V_{s_i} &= G I_{s_i} R \\ &= G D P_R(t) R \end{aligned} \quad (6)$$

$$V_{s_o} = G D R P_R(t) * h(t) , \text{ where } * \text{ denotes convolution.} \quad (7)$$

The available signal power at the output of the detector filter, $h(t)$, becomes

$$S = \frac{V_{s_0}^2}{4R}$$

$$= (GDE_R)^2 \frac{R}{4} [s(t)*h(t)]^2 . \quad (8)$$

The photodetector output current contains several sources of noise, including thermal noise, dark-current noise, background noise, and signal shot noise. These noise sources can be modelled by assuming that each noise source acts as a voltage in series with a resistor (fig 6). The available noise power is given by the relationship

$$N = \frac{\overline{v^2}}{4R} , \quad (9)$$

where

$$\overline{v^2} = G_V(j\omega) \int |H(j\omega)|^2 \frac{d\omega}{2\pi} . \quad (10)$$

except for signal shot noise (ref 2), where

$$\overline{v^2} = G_V(t)*h^2(t)$$

$$= \int \frac{G_V(j\omega)}{2\pi} [H(j\omega)*H(j\omega)] e^{j\omega t} \frac{d\omega}{2\pi} . \quad (10a)$$

and $G_V(j\omega)$ is the noise power spectral density in voltage units. Table 1 lists the spectral density for each noise source.

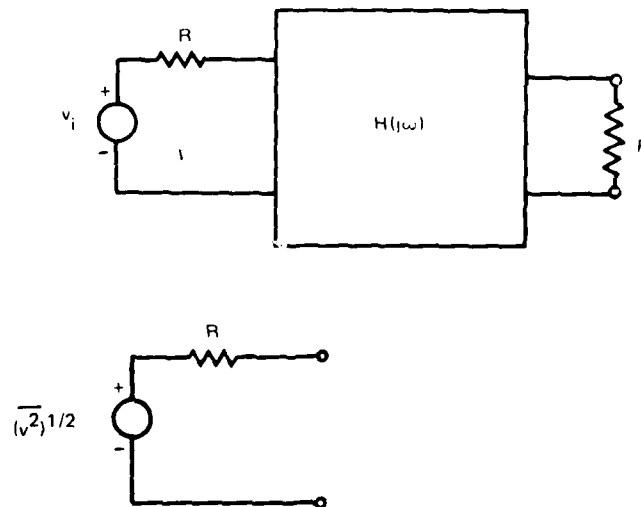

Figure 6. Noise model representation.

- Receiver Design for Digital Fiber Optic Communication Systems, I, by SD Personick, Bell System Technical Journal, vol 52, p 843, 1973.

Noise Source	$G_v(j\omega)$
Thermal	$2KTR$
Dark current	$G^2 q I_D R^2$
Background	$G^2 q I_B R^2$
Signal shot	$G^2 q I_S(j\omega) R^2$

Table 1. Noise source units.

On substituting the values in table 1 into equations (9) and (10), the resulting noise powers become

$$N_{\text{thermal}} = \frac{KT}{2} \int |H(j\omega)|^2 \frac{d\omega}{2\pi} \quad (11)$$

$$N_{\text{dark current}} = \frac{G^2 q I_D R}{4} \int |H(j\omega)|^2 \frac{d\omega}{2\pi} \quad (12)$$

$$N_{\text{background}} = \frac{G^2 q D P_B R}{4} \int |H(j\omega)|^2 \frac{d\omega}{2\pi} \quad (13)$$

$$N_{\text{signal shot}} = \frac{G^2 q D R}{4} \int \frac{P_S(j\omega)}{2\pi} [H(j\omega) * H(j\omega)] e^{j\omega t} \frac{d\omega}{2\pi}, \quad (14)$$

where

K = Boltzmann's constant ($W \cdot s/K$)

T = resistor temperature (K)

G = photodetector current gain

q = electron charge ($A \cdot s$)

D = receiver responsivity (A/W)

I_D = dark current (A)

P_B = background power (W)

P_S = signal shot noise (W).

The total noise power at the output of the detection filter is the summation

$$N = N_{\text{thermal}} + N_{\text{dark current}} + N_{\text{background}} + N_{\text{signal shot}} \quad (15)$$

For this system the dominant noise source is background noise. Consequently the received noise power is approximated by the relationship

$$N = N_{\text{background}} \quad (16)$$

Thus the resulting received SNR is as follows:

$$\frac{S}{N} = \frac{(GDE_R)^2 \frac{R}{4} [s(t) * h(t)]^2}{G^2 q D P_B \frac{R}{4} \int |H(j\omega)|^2 \frac{d\omega}{2\pi}} \quad (17)$$

Equation (17) then reduces to the following:

$$\frac{S}{N} = \frac{D}{q} \frac{E_R^2}{P_B} \frac{[s(t)*h(t)]^2}{\int |H(j\omega)|^2 \frac{d\omega}{2\pi}} \quad (18)$$

or

$$\frac{S}{N} = \frac{D}{q} \frac{E_R^2}{P_B} \frac{P_D}{t_m} \quad (19)$$

where

$$\frac{P_D}{t_m} = \frac{[s(t)*h(t)]^2}{\int |H(j\omega)|^2 \frac{d\omega}{2\pi}} \quad (20)$$

and P_D represents the postdetection effect.

POSTDETECTION EFFECTS

Since the received signal, $s(t)$, is known and various postdetection methods can be represented by the filter, $h(t)$, one can determine the postdetection effects of equation (20). Three types of postdetection are examined: the integrator, the matched filter, and a low-pass filter.

INTEGRATOR

The integrator is modelled by the process

$$\begin{aligned} y_s(t) &= s(t)*h(t) \\ &= \int_{t-T}^t s(\lambda) d\lambda \end{aligned} \quad (21)$$

where $y_s(t)$ represents the output of the postdetection filter at time t and T is the integration time $t_2 - t_1$. At $t = t_2$, the output of the postdetection filter is as follows:

$$y_s(t_2) = \int_{t_1}^{t_2} s(\lambda) d\lambda \quad (22)$$

With reference to equation (21), the postdetection filter is as follows:

$$h(t) = u(t) - u(t - T) \quad (23)$$

$$\text{Since } \int h^2(t) dt = \int |H(j\omega)|^2 \frac{d\omega}{2\pi} ,$$

$$\begin{aligned} \int |H(j\omega)|^2 \frac{d\omega}{2\pi} &= \int [u(t) - u(t - T)]^2 dt \\ &= T \end{aligned} \quad (24)$$

Since $s(t) = \frac{te^{-t/t_m}}{t_m^2}$, equation (21) becomes

$$\begin{aligned}
 y_s(t) &= s(t) * h(t) \\
 &= \int_{t-T}^t s(\lambda) d\lambda \\
 &= \int_{t-T}^t \frac{e^{-\lambda/t_m}}{t_m^2} d\lambda \\
 &= e^{-t/t_m} \left[e^{T/t_m} \left(\frac{t}{t_m} - \frac{T}{t_m} + 1 \right) - \left(\frac{t}{t_m} + 1 \right) \right].
 \end{aligned} \tag{25}$$

If equations (25) and (24) are substituted into equation (20), the postdetection effect for the integrator becomes

$$\begin{aligned}
 P_D &= t_m \frac{\left[y_s^2(t) \Big|_{t=t_2} \right]}{\int |H(j\omega)|^2 \frac{d\omega}{2\pi}} \\
 &= \frac{e^{-2t_1/t_m}}{T/t_m} \left[\frac{t_1}{t_m} + 1 - e^{-T/t_m} \left(\frac{T}{t_m} + \frac{t_1}{t_m} + 1 \right) \right]^2.
 \end{aligned} \tag{26}$$

To maximize the SNR of equation (19), P_D must be maximized. P_D is maximized by determining the integration start time, t_1 , over a fixed integration period, T . This implies that

$$\frac{\partial}{\partial t_1} (P_D) = 0. \tag{27}$$

To satisfy equation (27) requires that

$$\frac{t_1}{t_m} = \frac{T/t_m}{e^{T/t_m} - 1}. \tag{28}$$

The optimum integrator implies that for a given integration period, T , the start time of the integration, t_1 , must be related to equation (28). Table 2 shows some representative integration start times (t_1), integration periods (T), and the resulting P_D .

Figure 7 is a plot of equations (26) and (28) showing the optimum integrator post-detection (P_D) loss for various integration periods. Notice that when the integration period $T = 3t_m$, the postdetection effect is minimized.

Integration Period, T/t_m	Integration Start Time, t_1/t_m	Post- detection Effect, P_D
1	0.501976707	0.124327446
0.1	0.548856735	0.124938245
0.2	0.512150113	0.144638606
0.3	0.417019677	0.153696779
0.4	0.453275145	0.162146921
0.5	0.430825705	0.169978932
0.6	0.404752562	0.177188210
0.7	0.370077648	0.183753224
0.8	0.350460523	0.189745637
0.9	0.334160265	0.195188879
2	0.312035708	0.198878686
0.1	0.293017565	0.204072139
0.2	0.274143241	0.207709189
0.3	0.256239075	0.210812384
0.4	0.239445052	0.213406017
0.5	0.223503725	0.215516211
0.6	0.208605155	0.217170002
0.7	0.194528256	0.218395196
0.8	0.181292589	0.219219957
0.9	0.168858475	0.219672408
3	0.157167089	0.219780740
0.1	0.146240547	0.219572210
0.2	0.135981378	0.219073645
0.3	0.126375584	0.218310975
0.4	0.117386696	0.217309091
0.5	0.108981807	0.216091788
0.6	0.101128611	0.214681664
0.7	0.093796016	0.213100067
0.8	0.086954165	0.211367071
0.9	0.080574435	0.209501455
4	0.074629441	0.207520710
0.1	0.069093025	0.205441059
0.2	0.063940243	0.203277406
0.3	0.059147348	0.201043772
0.4	0.054691765	0.198752543
0.5	0.050552067	0.196415325
0.6	0.046707945	0.194042594
0.7	0.043140174	0.191640836
0.8	0.039830581	0.189227615
0.9	0.036762002	0.186801613
5	0.033918275	0.184372712

Table 2. Optimum integrator postdetection effect.

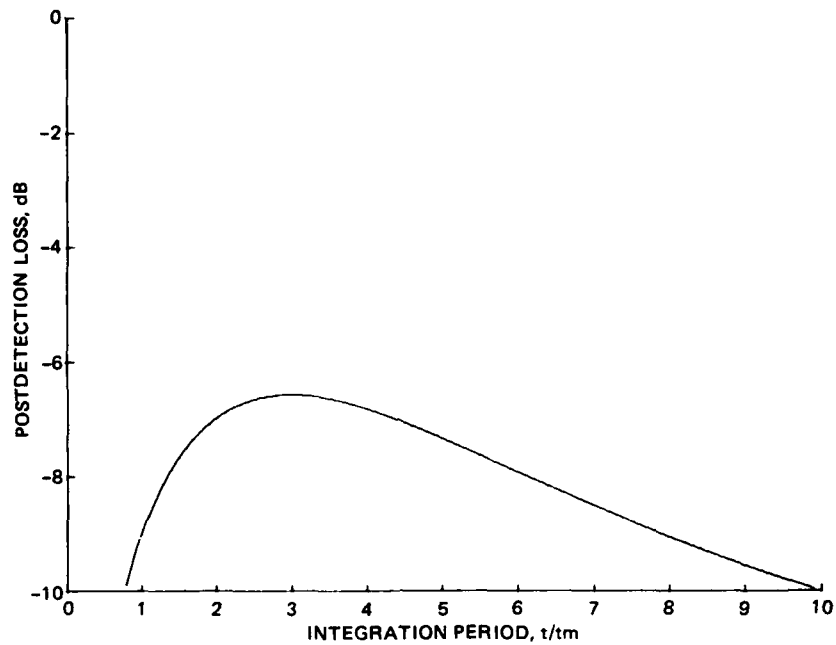

Figure 7. Optimum integrator postdetection effect.

MATCHED FILTER

The matched filter process is represented by a filter response

$$h(t) = s(\Delta - t) [u(t) - u(t - \Delta)] , \quad (29)$$

where Δ is the observation time length of the filter. The output of the postdetection filter for signal only is

$$y_s(t) = s(t) * h(t) . \quad (30)$$

Hence if equation (29) is substituted into equation (30) and the result is evaluated at $t = \Delta$,

$$y_s(t) \Big|_{t = \Delta} = \int s(t - \tau) h(\tau) d\tau \Big|_{t = \Delta}$$

$$\begin{aligned}
&= \int_0^{\Delta} s(t-\tau) s(\Delta-\tau) d\tau \Big|_{t=\Delta} \\
&= \int_0^{\Delta} s^2(\tau) d\tau .
\end{aligned} \tag{31}$$

Since $s(t) = \frac{te^{-t/t_m}}{t_m^2}$, equation (31) becomes

$$\begin{aligned}
y_s(t) \Big|_{t=\Delta} &= \int_0^{\Delta} \frac{\tau^2 e^{-2\tau/t_m}}{t_m^4} d\tau \\
&= \frac{1}{4t_m} \left\{ 1 - e^{-\frac{2\Delta}{t_m}} \left[2\left(\frac{\Delta}{t_m}\right)^2 + 2\left(\frac{\Delta}{t_m}\right) + 1 \right] \right\} .
\end{aligned} \tag{32}$$

Since $\int |H(j\omega)|^2 \frac{d\omega}{2\pi} = \int h^2(t) dt$,

$$\begin{aligned}
\int |H(j\omega)|^2 \frac{d\omega}{2\pi} &= \int_0^{\Delta} s^2(\Delta-t) dt \\
&= \int_0^{\Delta} s^2(t) dt .
\end{aligned} \tag{33}$$

If equations (32) and (33) are substituted into equation (20), the postdetection effect for the matched filter becomes

$$\begin{aligned}
P_D &= t_m \frac{\left[y_s^2(t) \Big|_{t=\Delta} \right]}{\int |H(j\omega)|^2 \frac{d\omega}{2\pi}} \\
&= \frac{1}{4} \left\{ 1 - e^{-\frac{2\Delta}{t_m}} \left[2\left(\frac{\Delta}{t_m}\right)^2 + 2\left(\frac{\Delta}{t_m}\right) + 1 \right] \right\} .
\end{aligned} \tag{34}$$

The postdetection effect for the matched filter is listed in table 3. Figure 8 shows the relationship between the observation time of the postdetection filter and the postdetection SNR effect.

RC LOW-PASS FILTER

The postdetection filter response for the RC low-pass filter is as follows:

$$h(t) = \frac{1}{RC} e^{-t/RC} u(t) . \tag{35}$$

Filter Observation Time, Δ/t_m	Post- detection Effect, P_D
1	0.080880896
1.1	0.094321563
1.2	0.107572813
1.3	0.120392606
1.4	0.132636579
1.5	0.144292480
1.6	0.155024065
1.7	0.165065028
1.8	0.174313289
1.9	0.182775891
2	0.190474174
2.1	0.197440503
2.2	0.203714429
2.3	0.209340324
2.4	0.214365195
2.5	0.218836995
2.6	0.222803337
2.7	0.226310533
2.8	0.229402899
2.9	0.233122289
3	0.234567799
3.1	0.236595611
3.2	0.238418946
3.3	0.240008097
3.4	0.241390518
3.5	0.242590959
3.6	0.243631623
3.7	0.244532344
3.8	0.24531077
3.9	0.245982549
4	0.246561508
4.1	0.247059834
4.2	0.247488232
4.3	0.247856088
4.4	0.248171608
4.5	0.248441951
4.6	0.248673353
4.7	0.248871230
4.8	0.249040284
4.9	0.249184584
5	0.249307651

Table 3. Matched filter postdetection effect.

The postdetection filter for signal only has the following output response:

$$\begin{aligned}
 y_s(t) &= s(t) * h(t) \\
 &= \int s(\tau) h(t-\tau) d\tau \\
 &= \int_0^t \frac{\tau e^{-\tau/t_m}}{t_m^2} \frac{1}{RC} e^{-(t-\tau)/RC} d\tau \\
 &= \frac{1}{t_m^2 RC} \frac{1}{\left(\frac{1}{RC} - \frac{1}{t_m}\right)^2} \left\{ e^{-t/RC} - e^{-t/t_m} \left[1 - \left(\frac{1}{RC} - \frac{1}{t_m}\right) t \right] \right\}. \quad (36)
 \end{aligned}$$

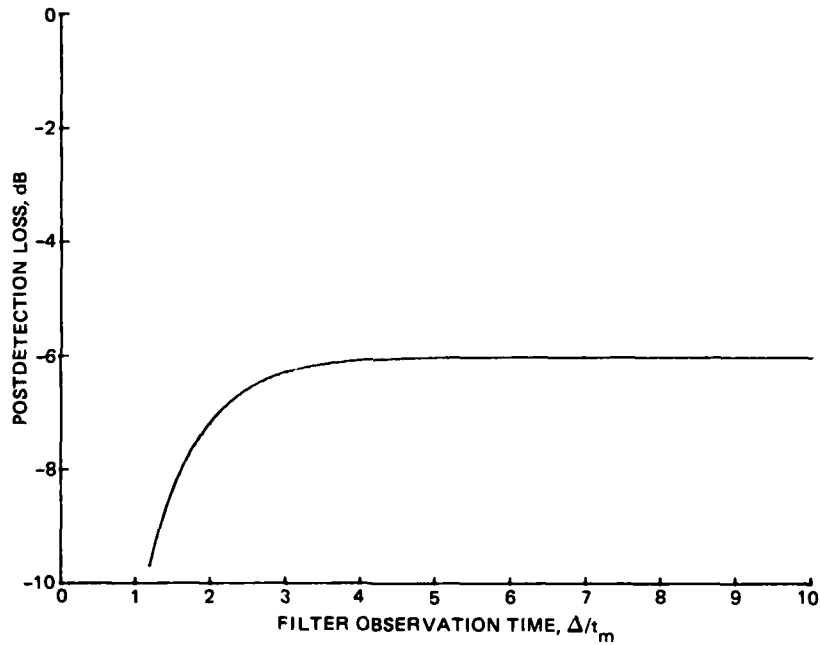

Figure 8. Matched filter postdetection effect.

The response

$$\begin{aligned}
 \int |H(j\omega)|^2 \frac{d\omega}{2\pi} &= \int_0^\infty \left(\frac{1}{RC}\right)^2 e^{-2t/RC} dt \\
 &= \left(\frac{1}{2}\right) \left(\frac{1}{RC}\right). \quad (37)
 \end{aligned}$$

If equations (36) and (37) are substituted into equation (20), the postdetection effect for the low-pass filter becomes

$$P_D = \frac{t_m \left[y_s^2(t) \right]_{t=t}}{\int |H(j\omega)|^2 \frac{d\omega}{2\pi}}$$

$$= \begin{cases} \frac{2t_m/RC}{\left(\frac{t_m}{RC} - 1\right)^4} \left\{ e^{-\frac{t_m}{RC} \frac{t}{t_m}} - e^{-t/t_m} \left[1 - \left(\frac{t_m}{RC} - 1\right) \frac{t}{t_m} \right] \right\}^2, \\ \text{where } RC/t_m \neq 1, \text{ and} \\ \frac{1}{2} \frac{t_m}{RC} \left(\frac{t}{t_m}\right)^4 e^{-2\frac{t_m}{RC} \frac{t}{t_m}}, \text{ where } RC/t_m = 1. \end{cases} \quad (38)$$

The postdetection filter effect is listed in table 4 for $RC/t_m = 2$. Figure 9 shows the RC low-pass filter postdetection effect vs filter output times for various values of the parameter RC/t_m .

Filter Output Time, t/t_m	Post-detection Effect, P_D
1	0.97807560
1.1	0.963535279
1.2	0.947611680
1.3	0.930734776
1.4	0.913729082
1.5	0.896732337
1.6	0.87982133
1.7	0.863022021
1.8	0.846495346
1.9	0.830250045
2	0.814293645
2.1	0.79865915
2.2	0.783390766
2.3	0.768475479
2.4	0.753988804
2.5	0.739955287
2.6	0.726494582
2.7	0.713521072
2.8	0.701095822
2.9	0.689243772
3	0.67798589
3.1	0.66732484
3.2	0.657294344
3.3	0.647838554
3.4	0.638914149
3.5	0.630571423
3.6	0.62285631
3.7	0.615728732
3.8	0.609147500
3.9	0.603059601
4	0.597496632
4.1	0.592414423
4.2	0.587843395
4.3	0.5837008345
4.4	0.5799831858
4.5	0.5766923721
4.6	0.5738012336
4.7	0.571292127
4.8	0.5691392127
4.9	0.5672974524
5	0.565763335
5.1	0.5644760089

Table 4. Low-pass filter postdetection effect for $RC/t_m = 2$.

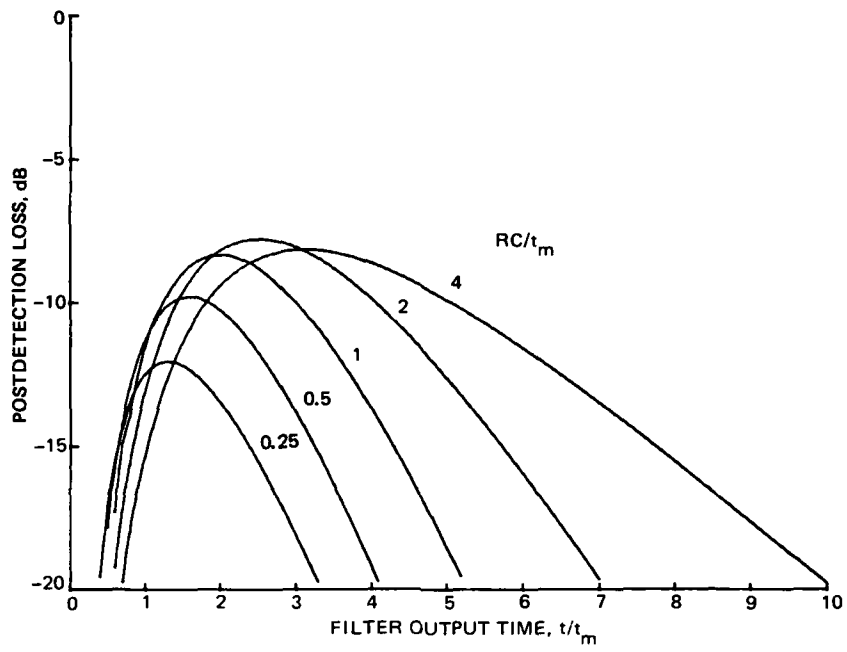

Figure 9. Low-pass filter postdetection effect for various values of the parameter RC/t_m .

SUMMARY

When communicating optically from a spaceborne transmitter to a submerged receiving platform, noncoherent detection must be used because there is a spatial coherence loss due to the channel (clouds and water). For a noncoherent optical receiver operating in background-limited noise conditions, the received SNR is derived as follows:

$$\text{SNR} = \left(\frac{D}{q} \right) \left(\frac{E_R^2}{P_B} \right) \left(\frac{P_D}{t_m} \right),$$

where

D = responsivity
q = electron charge
E_R = received signal energy
P_B = background noise power
t_m = time for pulse to peak
P_D = postdetection effect
$$= t_m \frac{[s(t)*h(t)]^2}{\int |H(j\omega)| \frac{d\omega}{2\pi}}$$

P_D is the parameter used to characterize the effect of postdetection on the received SNR. Assuming perfect knowledge of both the pulse arrival time and the received pulse shape, the minimum amount of loss in the received SNR due to the postdetection filters for background-limited noise conditions is 6.58 dB for the optimum integrator, 6 dB for the matched filter, and 7.8 dB for the low-pass filter.

This report is a preliminary discussion of the effects of postdetection on the received SNR. It assumes perfect knowledge of both pulse arrival time and received pulse shape. A final report will contain analyses showing the degradation caused by timing uncertainties associated with pulse arrival time and by the uncertainty in the received pulse shape.

BIBLIOGRAPHY

1. M Gagliardi and S Karp, Optical Communications; JW Wiley and Sons, New York, 1976.
2. WK Pratt, Laser Communication Systems; JW Wiley and Sons, New York, 1969.
3. G Cooper and C McGillen, Methods of Signal and System Analysis; Holt, Rinehart and Winston, New York et al, 1967.

DA
FILM
O —