

AD-A104 613

CONSOER TOWNSEND AND ASSOCIATES LTD ST LOUIS MO  
NATIONAL DAM SAFETY PROGRAM. BROOKFIELD CITY DAM (MO 10181); GR--ETC(U)  
DEC 79 W G SHIFRIN DACW43-79-C-0075

F/G 13/13

UNCLASSIFIED

NL

1 of 2  
55  
1008-3

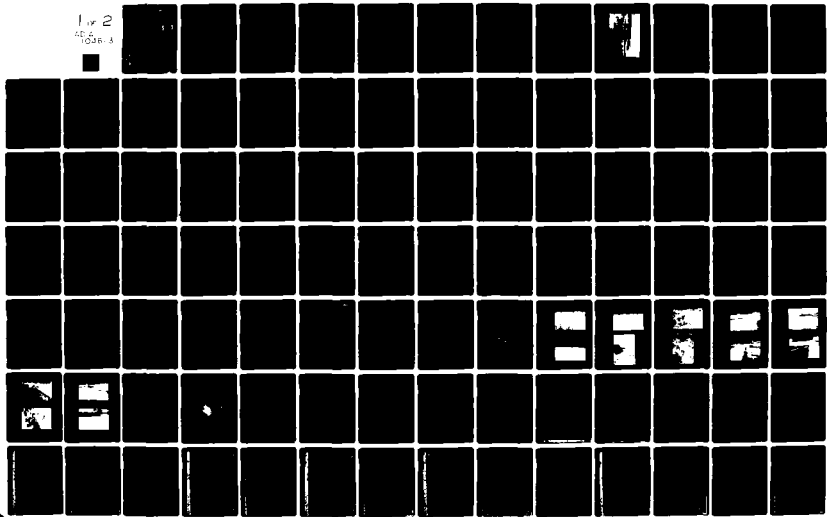

**LEVEL II**

①  
RS

**GRAND-CHARITON RIVER BASIN**

AD A104613

BROOKFIELD CITY DAM  
LINN COUNTY, MISSOURI  
MO. 10181

**ADTIC**  
**ELECTE**  
SEP 28 1981  
**S D**  
**E**

**PHASE I INSPECTION REPORT**  
**NATIONAL DAM SAFETY PROGRAM**



**United States Army**  
**Corps of Engineers**

*... Serving the Army*  
*... Serving the Nation*

**St. Louis District**

THIS DOCUMENT IS BEST QUALITY PRACTICABLE.  
THE COPY FURNISHED TO DDC CONTAINED A  
SIGNIFICANT NUMBER OF PAGES WHICH DO NOT  
REPRODUCE LEGIBLY.

PREPARED BY: U. S. ARMY ENGINEER DISTRICT, ST. LOUIS

FOR: STATE OF MISSOURI

This document has been approved  
for public release and sale; its  
distribution is unlimited.

DECEMBER 1979

81 9 28 130

DTIC FILE COPY

135

## **DISCLAIMER NOTICE**

**THIS DOCUMENT IS BEST QUALITY  
PRACTICABLE. THE COPY FURNISHED  
TO DTIC CONTAINED A SIGNIFICANT  
NUMBER OF PAGES WHICH DO NOT  
REPRODUCE LEGIBLY.**

UNCLASSIFIED

SECURITY CLASSIFICATION OF THIS PAGE (When Data Entered)

REPORT DOCUMENTATION PAGE		READ INSTRUCTIONS BEFORE COMPLETING FORM
1. REPORT NUMBER	2. GOVT ACCESSION NO. A 104613	3. RECIPIENT'S CATALOG NUMBER
4. TITLE (and Subtitle) Phase I Dam Inspection Report National Dam Safety Program Brookfield City Dam (MO 10181) Linn County, Missouri		5. TYPE OF REPORT & PERIOD COVERED Final Report
7. AUTHOR(s) Consoer, Townsend and Associates, Ltd.		6. PERFORMING ORG. REPORT NUMBER
9. PERFORMING ORGANIZATION NAME AND ADDRESS U.S. Army Engineer District, St. Louis Dam Inventory and Inspection Section, LMSED-PD 210 Tucker Blvd., North, St. Louis, Mo. 63101		8. CONTRACT OR GRANT NUMBER(s) DACW43-79-C-0075
11. CONTROLLING OFFICE NAME AND ADDRESS U.S. Army Engineer District, St. Louis Dam Inventory and Inspection Section, LMSED-PD 210 Tucker Blvd., North, St. Louis, Mo. 63101		10. PROGRAM ELEMENT, PROJECT, TASK AREA & WORK UNIT NUMBERS
14. MONITORING AGENCY NAME & ADDRESS (if different from Controlling Office) National Dam Safety Program. Brookfield City Dam (MO 10181), Grand - Chariton River Basin, Linn County, Missouri. Phase I Inspection Report.		12. REPORT DATE December 1979
16. DISTRIBUTION STATEMENT (of this Report) Approved for release; distribution unlimited.		13. NUMBER OF PAGES Approximately 70
17. DISTRIBUTION STATEMENT (of the abstract entered in Block 20, if different from Report)		15. SECURITY CLASS. (of this report) UNCLASSIFIED
18. SUPPLEMENTARY NOTES		15a. DECLASSIFICATION/DOWNGRADING SCHEDULE
19. KEY WORDS (Continue on reverse side if necessary and identify by block number) Dam Safety, Lake, Dam Inspection, Private Dams		
20. ABSTRACT (Continue on reverse side if necessary and identify by block number) This report was prepared under the National Program of Inspection of Non-Federal Dams. This report assesses the general condition of the dam with respect to safety, based on available data and on visual inspection, to determine if the dam poses hazards to human life or property.		

DD FORM 1473

EDITION OF 1 NOV 65 IS OBSOLETE

UNCLASSIFIED

SECURITY CLASSIFICATION OF THIS PAGE (When Data Entered)



DEPARTMENT OF THE ARMY  
 ST. LOUIS DISTRICT, CORPS OF ENGINEERS  
 210 NORTH 12TH STREET  
 ST. LOUIS, MISSOURI 63101

IN REPLY REFER TO

SUBJECT: Brookfield City Dam (Mo. 10181) Phase I Inspection Report

This report presents the results of field inspection and evaluation of the Brookfield City Dam (Mo. 10181).

It was prepared under the National Program of Inspection of Non-Federal Dams.

SUBMITTED BY: **SIGNED** 1 MAR 1980  
 Chief, Engineering Division

**31 MAR 1980**  
 Date

APPROVED BY: **SIGNED**  
 Colonel, CE, District Engineer

**31 MAR 1980**  
 Date

<b>Accession For</b>	
NTIS GRA&I	<input checked="" type="checkbox"/>
DTIC TAB	<input type="checkbox"/>
Unannounced	<input type="checkbox"/>
Justification	
By _____	
Distribution/ _____	
Availability Codes	
Dist	Avail and/or Special
<b>A</b>	<b>23</b> <b>CP</b>

BROOKFIELD CITY DAM  
LINN COUNTY, MISSOURI

MISSOURI INVENTORY NO. 10181

PHASE I INSPECTION REPORT  
NATIONAL DAM SAFETY PROGRAM

PREPARED BY  
CONSOER, TOWNSEND AND ASSOCIATES, LTD.  
ST. LOUIS, MISSOURI  
AND  
ENGINEERING CONSULTANTS, INC.  
ENGLEWOOD, COLORADO  
A JOINT VENTURE

UNDER DIRECTION OF  
ST. LOUIS DISTRICT, CORPS OF ENGINEERS  
FOR  
GOVERNOR OF MISSOURI

DECEMBER 1979

PHASE I INSPECTION REPORT  
NATIONAL DAM SAFETY PROGRAM

Name of Dam: Brookfield City Dam, Missouri Inv. No. 10181  
State Located: Missouri  
County Located: Linn  
Stream: An unnamed tributary of the West Yellow Creek  
Date of Inspection: August 22, 1979

Assessment of General Condition

Brookfield City Dam was inspected by the engineering firms of Consoer, Townsend and Associates, Ltd., and Engineering Consultants, Inc. (A Joint Venture) of St. Louis, Missouri according to the "Recommended Guidelines for Safety Inspection of Dams". These guidelines were developed by the Chief of Engineers, U.S. Army, Washington, D.C., with the help of Federal and State agencies, professional engineering organizations, and private engineers. The resulting guidelines are considered to represent a consensus of the engineering profession.

Based on the criteria in the guidelines, the dam is in the high hazard potential classification, which means that loss of life and appreciable property loss could occur in the event of failure of the dam. Within the estimated damage zone of two miles downstream of the dam are five dwellings, the Brookfield Country Club Lake and Dam, State Highway 11 and a railroad bridge which may be subjected to flooding, with possible damage and/or destruction,

and possible loss of life. Brookfield City Dam is in the intermediate size classification since it is more than 40 feet high and impounds more than 1,000 acre-feet but less than 50,000 acre-feet of water.

Our inspection and evaluation indicates that the spillway of Brookfield City Dam does not meet the criteria set forth in the guidelines for a dam having the above size and hazard potential. Brookfield City Dam, being an intermediate size dam with a high hazard potential, is required by the guidelines to pass the Probable Maximum Flood without overtopping. It was determined that the reservoir/spillway system can accommodate 89 percent of the Probable Maximum Flood without overtopping the dam. Our evaluation indicates that the reservoir/spillway system will accommodate the 100-year flood without overtopping.

The Probable Maximum Flood is defined as the flood discharge that may be expected from the most severe combination of critical meteorological and hydrologic conditions that are reasonably possible in the region. The 100-year flood is defined as a flood having a one percent chance of being equalled or exceeded during any given year.

Other deficiencies noted by the inspection team were: the sloughing of the upstream slope from 296 to 500 feet to the left from the left edge of the spillway; minor wave erosion on the upstream slope; the tree stumps on the upstream slope; the seepage observed at the toe of the dam; an unstable right retaining wall of the spillway; the vegetation upstream of the central section of the spillway and in the downstream channel; rodent activity on the embankment; a need for periodic inspection by a qualified engineer and a lack of maintenance schedule. The lack of stability and seepage analyses on record is also a deficiency that should be corrected.

It is recommended that the owner take action to correct  
or control the deficiencies described above.



Walter G. Shifrin, P.E.





Overview of Brookfield City Dam

PHASE I INSPECTION REPORT  
NATIONAL DAM SAFETY PROGRAM

BROOKFIELD CITY DAM, I.D. No. 10181

TABLE OF CONTENTS

<u>Sect. No.</u>	<u>Title</u>	<u>Page</u>
SECTION 1	PROJECT INFORMATION . . . . .	1
	1.1 General . . . . .	1
	1.2 Description of Project . . . . .	3
	1.3 Pertinent Data . . . . .	7
SECTION 2	ENGINEERING DATA . . . . .	9
	2.1 Design . . . . .	9
	2.2 Construction . . . . .	9
	2.3 Operation . . . . .	9
	2.4 Evaluation . . . . .	9
SECTION 3	VISUAL INSPECTION . . . . .	11
	3.1 Findings . . . . .	11
	3.2 Evaluation . . . . .	16

TABLE OF CONTENTS

(Continued)

<u>Sect. No.</u>	<u>Title</u>	<u>Page</u>
SECTION 4	OPERATION PROCEDURES . . . . .	17
	4.1 Procedures . . . . .	17
	4.2 Maintenance of Dam . . . . .	17
	4.3 Maintenance of Operating Facilities . . . . .	17
	4.4 Description of Any Warning System in Effect . . . . .	18
	4.5 Evaluation . . . . .	18
SECTION 5	HYDRAULIC/HYDROLOGIC . . . . .	19
	5.1 Evaluation of Features . . . . .	19
SECTION 6	STRUCTURAL STABILITY. . . . .	23
	6.1 Evaluation of Structural Stability. . . . .	23
SECTION 7	ASSESSMENT/REMEDIAL MEASURES. . . . .	26
	7.1 Dam Assessment . . . . .	26
	7.2 Remedial Measures. . . . .	28

TABLE OF CONTENTS

(Continued)

LIST OF PLATES

	<u>Plate No.</u>
LOCATION MAP . . . . .	1
PLAN, ELEVATION AND SECTION OF DAM . . . . .	2
DESIGN DRAWINGS . . . . .	3-9
GEOLOGIC MAP . . . . .	10
SEISMIC ZONE MAP . . . . .	11

APPENDICES

APPENDIX A	-	PHOTOGRAPHS
APPENDIX B	-	HYDROLOGIC COMPUTATIONS

PHASE I INSPECTION REPORT  
NATIONAL DAM SAFETY PROGRAM

BROOKFIELD CITY DAM, Missouri Inv. No. 10181

SECTION 1: PROJECT INFORMATION

1.1 General

a. Authority

The Dam Inspection Act, Public Law 92-367 of August, 1972, authorizes the Secretary of the Army, through the Corps of Engineers, to initiate a national program of dam inspections. Inspection for Brookfield City Dam was carried out under Contract DACW 43-79-C-0075 between the Department of the Army, St. Louis District, Corps of Engineers, and the engineering firms of Consoer, Townsend & Associates, Ltd., and Engineering Consultants, Inc. (A Joint Venture), of St. Louis, Missouri.

b. Purpose of Inspection

The visual inspection of Brookfield City Dam was made on August 22, 1979. The purpose of the inspection was to make a general assessment as to the structural integrity and operational adequacy of the dam embankment and its appurtenant structures.

c. Scope of Report

This report summarizes available pertinent data relating to the project; presents a summary of visual observations made during the field inspection; presents an assessment of hydrologic and hydraulic conditions at the site; presents an assessment as to the structural adequacy of the various project features; and assesses the general condition of the dam with respect to safety.

Subsurface investigations, laboratory testing, and detailed analyses were not within the scope of this study. No warranty as to the absolute safety of the project features is implied by the conclusions presented in this report.

It should be noted that reference in this report to left or right abutments is as viewed looking downstream. Where left abutment or left side of the dam is used in this report, this also refers to the east abutment or side, and right to the west abutment or side.

d. Evaluation Criteria

Criteria used to evaluate the dam were furnished by the Department of the Army, Office of the Chief of Engineers, in the publication "Recommended Guidelines for Safety Inspection of Dams", Appendix D. These guidelines were developed with the help of several Federal agencies and many State agencies, professional engineering organizations, and private engineers.

1.2 Description of the Project

a. Description of Dam and Appurtenances

The following description is based on observations and measurements made during the visual inspection, and available drawings.

The dam is a homogeneous structure between earth abutments. The crest is 18 feet wide and 1350 feet long. The crest elevation is 805 feet above MSL, and the maximum height of the embankment is 44 feet. According to the available drawings, the upstream and downstream slope are 1V to 3H and 1V to 3.5H, respectively. Riprap was provided for slope protection on the upstream slope.

According to the available drawings, a cutoff trench was provided upstream of the centerline of the dam. The trench is 4 feet deep with a bottom width of 12 feet and side slopes of 0.5V to 1H.

The spillway for Brookfield City Dam is located adjacent to the right abutment. The spillway is a rectangular, concrete-lined, uncontrolled open chute channel. The control section has a bottom width of 100 feet with vertical side walls 5.5 feet high. The spillway chute channel is 390 feet in length. According to the plans, the spillway is provided with 5 slab drains, but only 3 are known to exist. Energy dissipators were constructed at the downstream end of the channel.

A regulated outlet works used in the Brookfield domestic water supply system was provided for the dam. The water supply system associated with the dam consists of two centrifugal pumps located in a pumphouse which is located immediately downstream of the dam. The pumphouse is located approximately 450 feet to the right of the left abutment. Each pump is controlled by a 12-inch butterfly valve. The capacity of each pump is 750 to 1000 gpm. The intake of the system consists of two 10-inch steel pipes, 50 feet in length, connected to a manifold which can swivel to allow the ends of the pipes to be lowered and raised. A wood piling tower was provided in the reservoir with a hand operated winch used to raise and lower the intake. A strainer was provided on the end of each pipe. From the manifold, a 14-inch C.I.P. encased in concrete passes under the embankment to the pumphouse where the pipe branches into two 12-inch cast iron pipes. The two pipes pass through the pumping system in the pumphouse and converge into a 12-inch C.I.P. which goes to some storage lagoons. A pump is located at the storage lagoons which can pump water back into the Brookfield City reservoir through the same system. On one of the 12-inch lines into the pumphouse, a 12-inch drain pipe was provided which is controlled by a gate valve.

b. Location

The Brookfield City Dam is located on an unnamed tributary of the West Yellow Creek in Linn County, Missouri. The nearest community is Brookfield, which is about 2 miles to the west of the damsite. The dam and lake are located in Sections 33 and 34, Township 58 North, Range 19 West on the Brookfield Quadrangle Sheet (15 minute series).

c. Size Classification

According to the "Recommended Guidelines for Safety Inspection of Dams", by the U.S. Department of the Army, Office of the Chief Engineer, the dam is classified in the dam size category as being "Intermediate" since its storage is greater than 1,000 acre-feet and less than 50,000 acre-feet. The dam is also classified as "Intermediate" in dam size category because its height is less than 100 feet and greater than 40 feet. The overall size classification is, accordingly, "Intermediate" in size.

d. Hazard Classification

The dam has been classified as having "High" hazard potential in the National Inventory of Dams, on the basis that in the event of failure of the dam or its appurtenances, excessive damage could occur to downstream property, together with the possibility of the loss of life. Our findings concur with the classification. Within the estimated damage zone, which extends approximately 2 miles downstream from the dam, are five dwellings, the Brookfield Country Club Lake and Dam, State Highway 11 and a railroad bridge.

e. Ownership

The Brookfield City Dam is owned by the City of Brookfield. The mailing address is Brookfield City Hall, c/o Ray Epperly, Water Superintendent, Brookfield, Missouri, 64628.

f. Purpose of Dam

The main purpose of the dam is to impound water for domestic water supply and recreational use.

g. Design and Construction History

Brookfield City Dam was designed in 1959 by E. T. Archer Engineering of Kansas City, Missouri. According to the Brookfield Water Superintendent, Mr. Ray Epperly, the dam was constructed by Gibson and Bowles Construction of Lees Summit, Missouri.

h. Normal Operational Procedures

There are no specific operational procedures for the dam or the appurtenant structures. The only facilities at the site which require operation are the two pumps located in the pumphouse at the toe of the dam. The operational procedures of the pumps varies depending upon the demand for water. The pumps are used mostly during the winter months. The reservoir is allowed to remain as full as possible with the water level being controlled by rainfall, runoff, evaporation, the elevation of the spillway crest and the demand for water.

According to Tom Sturguess of the Brookfield Water Department, the pumping system associated with water supply lines allow them to pump water either to or from the city holding ponds located about a mile southwest from the reservoir. Mr. Sturguess also noted that it is possible to pump water from Yellow Creek into the reservoir to increase the quantity in storage.

1.3 Pertinent Data

a.	Drainage Area (square miles):	1.1
b.	Discharge at Damsite	
	Estimated experienced maximum flood (cfs):	NA
	Estimated ungated spillway capacity with reservoir at top of dam elevation (cfs):	3446
c.	Elevation (Feet above MSL)	
	Top of dam:	805.0
	Spillway crest:	800.0 (assumed)
	Normal Pool:	800.0
	Maximum Pool (PMF):	805.30
d.	Reservoir	
	Length of pool with water surface at top of dam elevation (feet):	5200
e.	Storage (Acre-Feet)	
	Top of dam:	2539
	Spillway crest:	1892
	Normal Pool:	1892
	Maximum Pool (PMF):	2591
f.	Reservoir Surface (Acres)	
	Top of dam:	141
	Spillway crest:	118
	Normal Pool:	118
	Maximum Pool (PMF):	143
g.	Dam	
	Type:	Earthfill
	Length:	1350 feet
	Structural Height:	44 feet

Hydraulic Height: 44 feet  
Top width: 18 feet  
Side slopes:  
    Downstream 1V to 3.5H  
    Upstream 1V to 3H  
Zoning: Homogeneous  
Impervious core: NA  
Cutoff: Cutoff trench, 12 foot wide, 4 foot deep with side slopes of 0.5V to 1H.  
Grout curtain: Unknown

h. Diversion and Regulating Tunnel None

i. Spillway

Type: Rectangular open chute channel, uncontrolled  
Length of crest: 100 feet  
Crest Elevation (feet above MSL): 800 (assumed)

j. Regulating Outlets

Type: 14-inch steel water supply pipe  
Length: 430 feet (According to plans)  
Closure: Two 12-inch butterfly valves  
Maximum Capacity: 1500 to 2000 gpm

## SECTION 2 : ENGINEERING DATA

### 2.1 Design

A full set of original design drawings are available from the Department of Natural Resources, Macon, Missouri. A partial set of the drawings are included as part of this report. The design engineering firm of E.T. Archer of Kansas City, Missouri was unable to provide any design calculations or specifications. The dam and appurtenant structures were part of the Sections III and IV Waterworks Improvements for Brookfield, Missouri project.

### 2.2 Construction

No construction records or as-built drawings were available for the Brookfield City Dam. The dam was constructed by Gibson and Bowles Construction Company of Lees Summit, Missouri.

### 2.3 Operation

No operation records are available for the Brookfield City Dam.

### 2.4 Evaluation

#### a. Availability

The availability of engineering data is poor and consists only of the design drawings mentioned in Section 2.1, State Geological Maps and U.S.G.S. Quadrangle Sheets. Information on subsurface soils underneath the dam is available

(see Plate 5). The subsurface soils consist of clayey soils, shale and sand and clay drift. No information on design hydrology, or hydraulic design was available, nor were seepage and stability analyses comparable to the requirements of the "Recommended Guidelines for Safety Inspection of Dams", which is considered a deficiency.

b. Adequacy

The conclusions presented in this report are based on field measurements, the available engineering data, past performance and present condition of the dam. The data available is inadequate to evaluate the hydraulic and hydrologic capabilities of the dam.

Seepage and stability analyses comparable to the requirements of the "Recommended Guidelines for Safety Inspection for Dams" were not available, which is considered a deficiency. These seepage and stability analyses should be performed for appropriate loading conditions (including earthquake loads) and made a matter of record.

c. Validity

Only a set of design drawings was available for review. From field measurements, the dam appears to have been constructed according to the available drawings, except for the discrepancies described in Section 1.2a.

SECTION 3: VISUAL INSPECTION

3.1 Findings

a. General

A visual inspection of the Brookfield City Dam was made on August 22, 1979. The following persons were present during the inspection:

<u>Name</u>	<u>Affiliation</u>	<u>Disciplines</u>
Dr. M.A. Samad	Engineering Consultants, Inc.	Project Engineer, Hydraulics and Hydrology
Mark R. Haynes	Engineering Consultants, Inc.	Civil, Structural and Mechanical
Dawn L. Jacoby	Engineering Consultants, Inc.	Soils
Peter L. Strauss	Engineering Consultants, Inc.	Geology
Kevin Blume	Consoer, Townsend & Assoc., Ltd.	Civil and Structural
Nancy Olinger	City of Brookfield	City Manager
Lavon Burris	City of Brookfield	Mayor

Tom Sturguess

City of Brookfield

Water Department

Norman Wood

Rhodes-Sayre & Associates,  
Consulting Engineers for the  
City of Brookfield

Professional  
Engineer

Specific observations are discussed below.

b. Dam

The dam is generally in good condition. The dam crest is protected from surface erosion by a well maintained cover of grass. No significant deviations in horizontal or vertical alignment were apparent. No bulges or depressions were observed. Non-continuous cracks measuring approximately 1-inch wide were observed on the crest, downstream slope, and the contact with the left abutment. The nature and cause of these cracks were not readily apparent, however; they do not appear to be related to slope movement. Tension cracks along the upstream side were observed in an area located 296 feet to 500 feet from the spillway. The crest was wider in this area. According to Mr. Tom Sturguess the dam has never been overtopped and there was no evidence indicating the contrary.

The upstream slope is generally protected from wave action by an adequate cover of sandstone riprap. Some minor erosion has occurred above the riprap due to wave action. The upper section of the slope is protected by a grass cover. Several bushes and large tree stumps were observed on the slope. The section of the embankment located from 296 feet to 500 feet to the left of the spillway has been badly undercut. The sandstone riprap has been replaced with concrete rubble.

The slope is sloughing as indicated by the tension cracks on the crest in this section.

The downstream slope is protected by a well maintained grass cover. No bulges or depressions were observed. There was some evidence of rodent activity on the slope. The embankment slope, from 206 feet to 318 feet, from the east edge of the spillway exhibited signs of seepage. Standing water was observed in the cattails located on the slope immediately above the toe. No signs of instability were observed.

The abutments were at approximately the same elevation as the crest of the dam. No instability of the abutment was observed. No seepage along the abutment and embankment contact was observed. Both abutments were protected from surface runoff by an adequate grass cover. The right abutment supports a gravel road.

c. Project Soils and Geology

According to the "Missouri General Soil Map and Soil Association Description" published by the Soil Conservation Service, the materials in the general area of the dam belong to the soil series of Pershing-Armstrong-Gara in the Deep Loess and Drift forest. The soils are basically formed from loess and glacial till. The permeability of these soils range from slow to moderately slow. The subsurface soils underneath the dam consist of clayey soils, shale and sand and clay drift (see Plate 5).

The damsite is physiographically located in the Dissected Till Plains Section of the Central Lowlands Physiographic Province, according to Nevin Fenneman's "Physiography of the Eastern United States." This section is distinguished from the Young Drift section on the north and from the Till Plains on the east by the stage it has reached in the post-glacial erosion cycle. Broadly generalized, this section is a nearly flat till plain submature to mature in its erosion cycle.

No faults have been identified in the vicinity of the dam.

Some minor folding has been identified in Linn County. The closest trace of any fold to the dam would be the northwest end of the College Mound-Bucklin anticline, 12 miles to the east, which had its last movement in late or post-Pennsylvanian. This minor structure has no effect on the dam.

The site bedrock geology, beneath the drift, as shown on the Geologic Map of Missouri, (1979), is interbedded Pennsylvanian age shales, limestones, sandstones. These strata generally strike north-south and dip gently to the west.

No bedrock was seen at or in the vicinity of the damsite. The entire area is mantled by glacial drift.

d. Appurtenant Structures

(1) Spillway

The overall condition of the spillway channel appeared to be good. Minor temperature cracks in the concrete were observed in the slab and left retaining wall of the spillway channel. No spalling of the concrete was observed. The entire right retaining wall of the channel, however, appeared to be unstable. In several locations along the wall, displacements from 1 to 3 inches were observed along the top at contraction and construction joints and portions of the wall appeared to be leaning forward. The last 130 feet of the wall was tilted forward approximately 20 degrees. The top of the wall was displaced 16 inches. The separation appears to have occurred at a construction joint. No reinforcement was exposed. No other instability was observed. The retaining walls were provided with weep holes at 20 foot centers and placed 6 inches above the spillway slab. A 2-foot high chain link trashrack was provided for the spillway. Some tall vegetation was growing upstream of the trashrack, however, the trashrack was unobstructed. The energy dissipators show no signs of deterioration.

(2) Outlet Works

According to Mr. Tom Sturguess of the Water Department of the City of Brookfield, the water supply system is operable. All valves are operable and the pumps are used regularly. The intake was inaccessible. The tower, which regulates the elevation of the intake, collapsed in 1976, therefore, the intake is lying at the bottom of the reservoir. Plans are being made to raise the structure.

e. Reservoir Area

The water surface elevation was at 798.7 feet above MSL on the day of the inspection.

The slopes along the reservoir rim are gently sloped with a good grass cover. In the past, the reservoir rim has experienced erosion which has been corrected by regrading and reseeding the slopes. No evidence of instability or erosion of the slopes was observed.

f. Downstream Channel

The downstream channel is obstructed by a heavy growth of vegetation and trees. The channel is about 15 feet wide and 5 feet deep. The channel meanders from the downstream end of the spillway channel to a culvert, 7 feet high by 14 feet wide, which passes under State Highway 11. Beyond the highway box culvert, the channel flows into the Brookfield Country Club Lake.

3.2 Evaluation

The visual inspection did not reveal any items which are sufficiently significant to indicate a need for immediate remedial action, however, the remedial measures in Section 7.2 should be undertaken within a reasonable period of time.

## SECTION 4: OPERATIONAL PROCEDURES

### 4.1 Procedures

Brookfield City Dam was built for domestic water supply for the City of Brookfield and the surrounding community. It is also used for recreational purposes.

No formal operational procedures are in effect for this dam. The pumps of the water supply system are operated depending upon the demand for water.

### 4.2 Maintenance of Dam

The dam is maintained by the City of Brookfield under the direction of Mr. Ray Epperly, the city Water Superintendent. The dam itself appears to be well maintained. The slopes and crest are mowed periodically and no trees have been allowed to grow on the embankment. Nevertheless, several items as mentioned in Section 7.2 should be attended to within a reasonable period of time.

### 4.3 Maintenance of Operating Facilities

The pumps are kept in operable condition. On the day of the inspection, the pumps were not operating.

4.4 Description of Any Warning System in Effect

The inspection team is not aware of any warning system in effect for this dam.

4.5 Evaluation

The operation and maintenance for Brookfield City Dam seems to be adequate. Nevertheless, the remedial measures as described in Section 7 should be undertaken as recommended.

## SECTION 5: HYDRAULIC/HYDROLOGIC

### 5.1 Evaluation of Features

#### a. Design

The watershed area of the Brookfield City Dam upstream from the dam axis consists of approximately 702 acres. The watershed area is mostly pasture and range land. Land gradients in the higher regions of the watershed average roughly 4 percent, and in the lower areas surrounding the reservoir average about 8 percent. The Brookfield City Dam Reservoir is located on an unnamed tributary of the West Yellow Creek. The reservoir is about 1.6 miles upstream from the confluence of the unnamed tributary and West Yellow Creek. At its longest arm the watershed is approximately 1/2 mile long. A drainage map showing the watershed is presented as Plate 1 in Appendix B.

Evaluation of the hydraulic and hydrologic features of Brookfield City Dam was based on criteria set forth in the Corps of Engineers' "Recommended Guidelines for Safety Inspection of Dams", and additional guidance provided by the St. Louis District of the Corps of Engineers. The Probable Maximum Flood (PMF) was calculated from the Probable Maximum Precipitation (PMP) using the methods outlined in the U.S. Weather Bureau Publication, Hydrometeorological Report No. 33. The probable maximum storm duration was set at 24 hours, and storm rainfall distribution was based on criteria given in the Corps of Engineers' EM 1110-2-1411 (Standard Project Storm). The Soil Conservation Service (SCS) method was used for

deriving the unit hydrograph, utilizing the Corps of Engineers' computer program HEC-1 (Dam Safety Version). The unit hydrograph parameters are presented in Appendix B. The SCS method was also used for determining the loss rate. The hydrologic soil group of the watershed was determined by use of published soil maps. The hydrologic soil group of the watershed and the SCS curve number are presented in Appendix B. The curve number, the unit hydrograph parameters, the PMP index rainfall and the percentages for various durations were directly input to the HEC-1 (Dam Safety Version) computer program to obtain the PMF hydrograph. The computed peak discharges of the PMF and one-half of the PMF are 13,909 cfs and 6,954 cfs, respectively.

Both the PMF and one-half of the PMF inflow hydrographs were routed through the reservoir by the Modified Puls Method also utilizing the HEC-1 (Dam Safety Version) computer program. The reservoir was assumed at the spillway crest level at the start of the routing computation. The peak outflow discharges for the PMF and one-half of the PMF are 4,548 and 1,723 cfs, respectively. Only the PMF when routed through the reservoir resulted in overtopping of the dam.

The size of physical features utilized to develop the stage-outflow relation for the spillway and overtopping of the dam were determined from field notes and sketches, prepared during the field inspection. The reservoir stage-capacity data were based on the U.S.G.S. Brookfield, Missouri Quadrangle topographic map (7.5 minute series). The spillway and dam overtop rating curve and the reservoir capacity curve are presented in Plates 2 & 3 respectively in Appendix B.

From the standpoint of dam safety, the hydrologic design of a dam must aim at avoiding overtopping. Overtopping is especially dangerous for an earth dam because of its erosive characteristics. The safe hydrologic design of an embankment dam requires a spillway discharge capability, in combination with an embankment crest height that can handle a very large and exceedingly rare flood without dam overtopping.

The Corps of Engineers design dams to safely pass the Probable Maximum Flood that is estimated could be generated from the dam's watershed. This is the generally accepted criterion for major dams throughout the world, and is the standard for dam safety where overtopping would pose any threat to human life. Accordingly, the hydrologic requirement for safety for this dam is the capability to pass the Probable Maximum Flood without overtopping.

b. Experience Data

It is believed that records of reservoir stage or spillway discharge are not maintained for this site.

c. Visual Observations

Observations made of the spillway during the visual inspection are discussed in Section 3.1.c(1) and evaluated in Section 3.2.

d. Overtopping Potential

As indicated in Section 5.1.a, only the Probable Maximum Flood when routed through the reservoir, resulted in overtopping of the dam. The peak outflow discharges for the PMF and one-half of the PMF are 4,548 and 1,723 cfs, respec-

tively. The maximum capacity of the spillway just before overtopping the dam is 3446 cfs. The PMF overtopped the dam crest by 0.30 feet. The total duration of embankment overflow is 0.75 hour. The spillway/reservoir system of Brookfield City Dam is capable of accommodating a flood equal to approximately 89 percent of the PMF before overtopping the dam. The spillway/reservoir system of Brookfield City Dam will accommodate the 100-year flood without overtopping.

The failure of the dam could cause extensive damage to the property downstream of the dam and possible loss of life. The estimated damage zone extends approximately two miles downstream of the dam. Within the damage zone are five dwellings, the Brookfield Country Club Lake and Dam, State Highway 11 and a railroad bridge.

## SECTION 6: STRUCTURAL STABILITY

### 6.1 Evaluation of Structural Stability

#### a. Visual Observations

The upstream slope is protected by riprap and vegetation. The dam crest and the downstream slope are protected by vegetation. The dam shows no signs of instability except for the area on the upstream slope to the left of the spillway which was repaired. The area that was severely undercut and is now sloughing should be monitored and repairs made as required to ensure the safety of the dam. The seepage observed at the toe does not appear to affect the structural stability of the dam in its present condition. No flowing seeps were observed. Nevertheless, the seepage area should be monitored and any changes in quantity, or color should be investigated. In the absence of seepage and stability analyses, no quantitative evaluation of the structural stability can be made.

The structural stability of the right retaining wall of the spillway channel appears to be in jeopardy. This condition, however, does not affect the structural integrity of the dam. If the wall was to collapse, the hydraulic capacity of the spillway would not be affected. No other instabilities were observed in the spillway or outlet works.

b. Design and Construction Data

No design computations were uncovered during the report preparation phase. Seepage and stability analyses comparable to the requirements of the "Recommended Guidelines for Safety Inspection of Dams" were not available. No embankment or foundation soil parameters are available for carrying out a conventional stability analysis on the embankment. No construction data or specifications relating to the degree of embankment compaction are available for use in a stability analysis.

c. Operating Records

No operating records are available relating to the stability of the dam or appurtenant structures. The water level on the day of the inspection was 1 foot 4 inches below the crest of the spillway, and it is assumed that the reservoir remains close to full at all times. The operation of the pumps depends on the demand for water.

d. Post Construction Changes

Stated in a letter addressed to the Director of Public Works of Brookfield, from Rhodes-Sayre & Associates, the consulting engineers for the city of Brookfield, a large slide occurred on the upstream slope several years prior to 1978. The slide was repaired by dumping concrete rubble on the area of the slide and then covering the area with soil. Consequently, the crest of the dam was widened. The upstream slope is steep in this area. This area appears to be the same area mentioned in Section 3.1b.

e. Seismic Stability

The dam is located in Seismic Zone 1, as defined in "Recommended Guidelines For Safety Inspection of Dams" as prepared by the Corps of Engineers. An earthquake of the magnitude expected in Seismic Zone 1 should not cause significant distress to a well designed and constructed earth dam.

## SECTION 7: ASSESSMENT/REMEDIAL MEASURES

### 7.1 Dam Assessment

The assessment of the general condition of the dam is based upon available data and visual inspections. Detailed investigations, testing, and detailed computational evaluations are beyond the scope of a Phase I investigation, however, the investigation is intended to identify any need for such studies.

It should be realized that the reported condition of the dam is based on observations of field conditions at the time of inspection along with data available to the inspection team.

It is also important to note that the condition of a dam depends on numerous and constantly changing internal and external conditions, and is evolutionary in nature. It would be incorrect to assume that the present condition of the dam will continue to represent the condition of the dam at some point in the future. Only through continued care and inspection can there be assurance that an unsafe condition could be detected.

#### a. Safety

The spillway capacity of Brookfield City Dam was found to be "Inadequate". The spillway/reservoir system will accommodate 89 percent of the PMF without overtopping the dam. The surface soils on the dam are quite silty. The dam is overtopped by about 4 inches during the PMF and the duration of embankment overflow is about one hour. If the material in the dam is silty soil, the dam would be susceptible to erosion and failure during overtopping.

No quantitative evaluation of the safety of the embankment can be made in view of the absence of seepage and stability analyses. The present embankment and appurtenant structures, however, appeared to have performed adequately since its construction without failure. The dam reportedly has never been overtopped and no evidence was uncovered indicating the contrary.

The erosion due to wave action, the unstable area to the left of the spillway on the upstream slope and the seepage observed on the toe do not affect the safety of the dam in their present conditions. Nevertheless, the conditions should be monitored and repairs made as required.

The vegetative growth upstream of the control section of the spillway and in the downstream channel does not pose a danger to the safety of the dam. These obstructions should, however, be removed in order to maintain the hydraulic efficiency of the spillway and the downstream channel.

The activity of burrowing animals observed on the embankment could jeopardize the safety of the dam. The holes created by the animals make avenues for possible piping. The extent of damage to the embankment done by the burrowing animals should be determined and corrective measures undertaken as required.

The tree stumps observed on the upstream slope pose a potential danger to the safety of the dam. Depending upon the extent of the existing root system, the roots as they rot present possible paths for piping through the embankment. Therefore, the stumps and their root systems should be removed from the embankment under the guidance of an engineer experienced in the design and construction of earthen dams.

b. Adequacy of Information

The conclusions presented in this report are based on field measurement, past performance and present condition of the dam. Information on the design hydrology, hydraulic design, and the operation and maintenance of the dam were not available. Seepage and stability analyses comparable to the requirements of the "Recommended Guidelines for Safety Inspection of Dams" were also not available, which is considered a deficiency.

c. Urgency

The remedial measures recommended in Paragraph 7.2 should be accomplished within a reasonable period of time.

d. Necessity for Phase II Inspection

Based on results of the Phase I inspection, and if the remedial measures recommended in Paragraph 7.2 are undertaken, a Phase II inspection is not felt to be necessary.

7.2 Remedial Measures

a. Alternatives

Spillway capacity and/or height of dam should be increased to accommodate the PMF without overtopping the dam.

b. O & M Procedures

1. Repair the unstable right retaining wall in the spillway channel.
2. Remove the tree stumps and their root systems observed on the upstream slope. Removal of the stumps and their root systems should be under the guidance of an engineer experienced in the design and construction of earthen dams.
3. Remove the vegetation from upstream of the control section of the spillway and in the downstream channel.
4. Determine the extent of damage done to the embankment by burrowing animals, if any, and make corrective repairs as required.
5. Seepage and stability analyses should be performed by a professional engineer experienced in the design and construction of earth dams.
6. Monitor the sloughing occurring on the upstream slope to the left of the spillway and the minor erosion due to wave action and make repairs as necessary.
7. Monitor the seepage observed on the downstream slope and any changes in quantity or color should be investigated.

8. The owner should initiate the following programs:

(a) Periodic inspection of the dam by a professional engineer experienced in the design and construction of earthen dams.

(b) Set up a maintenance schedule and log all visits to the dam for operation, repairs and maintenance.

PLATES

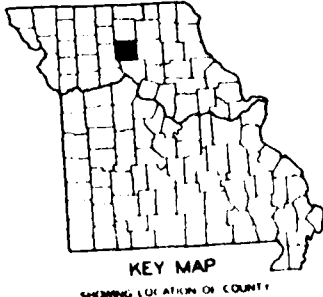
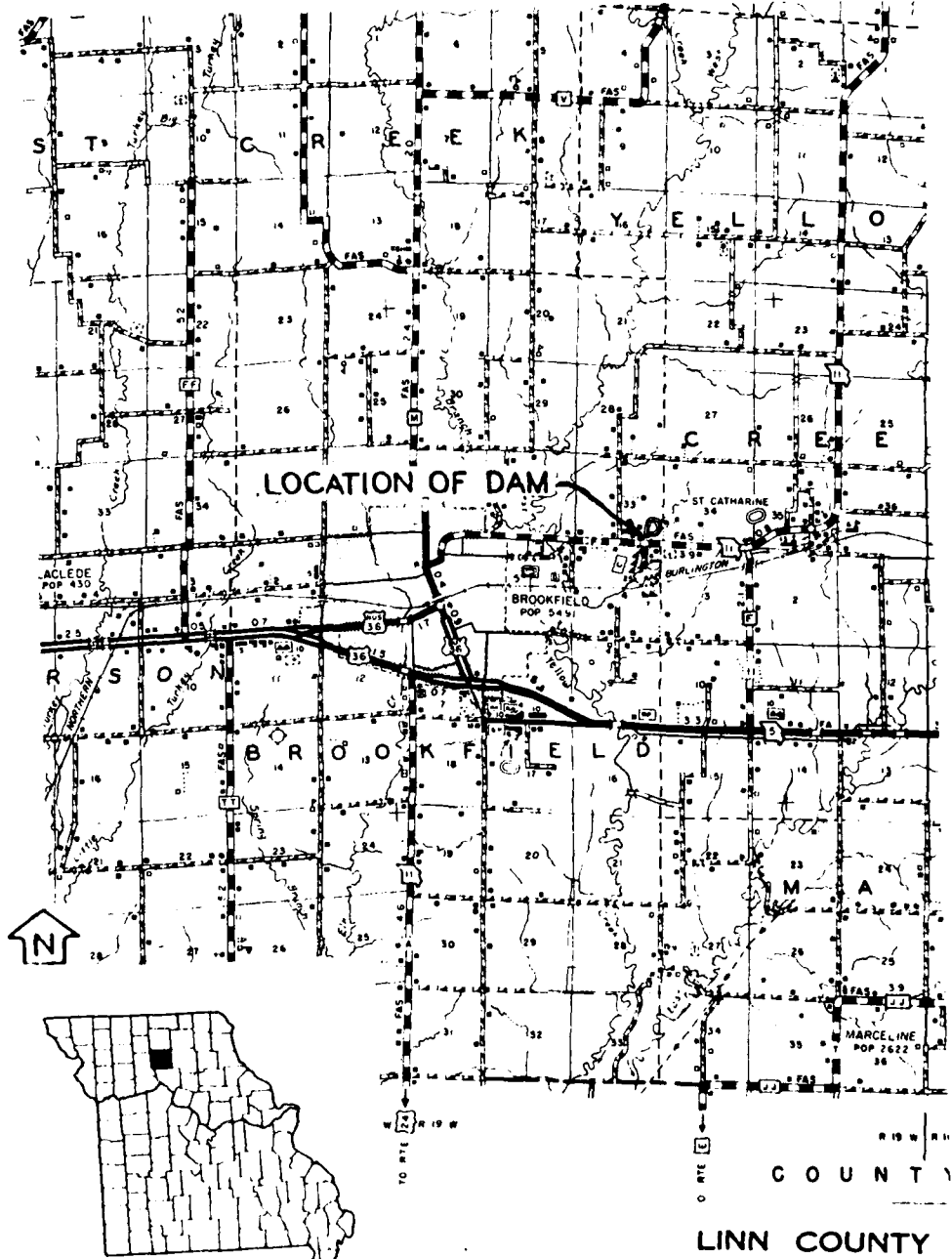

KEY MAP  
SHOWING LOCATION OF COUNTY

SCALE

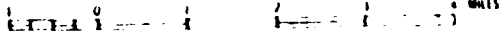

LOCATION MAP - BROOKFIELD CITY DAM

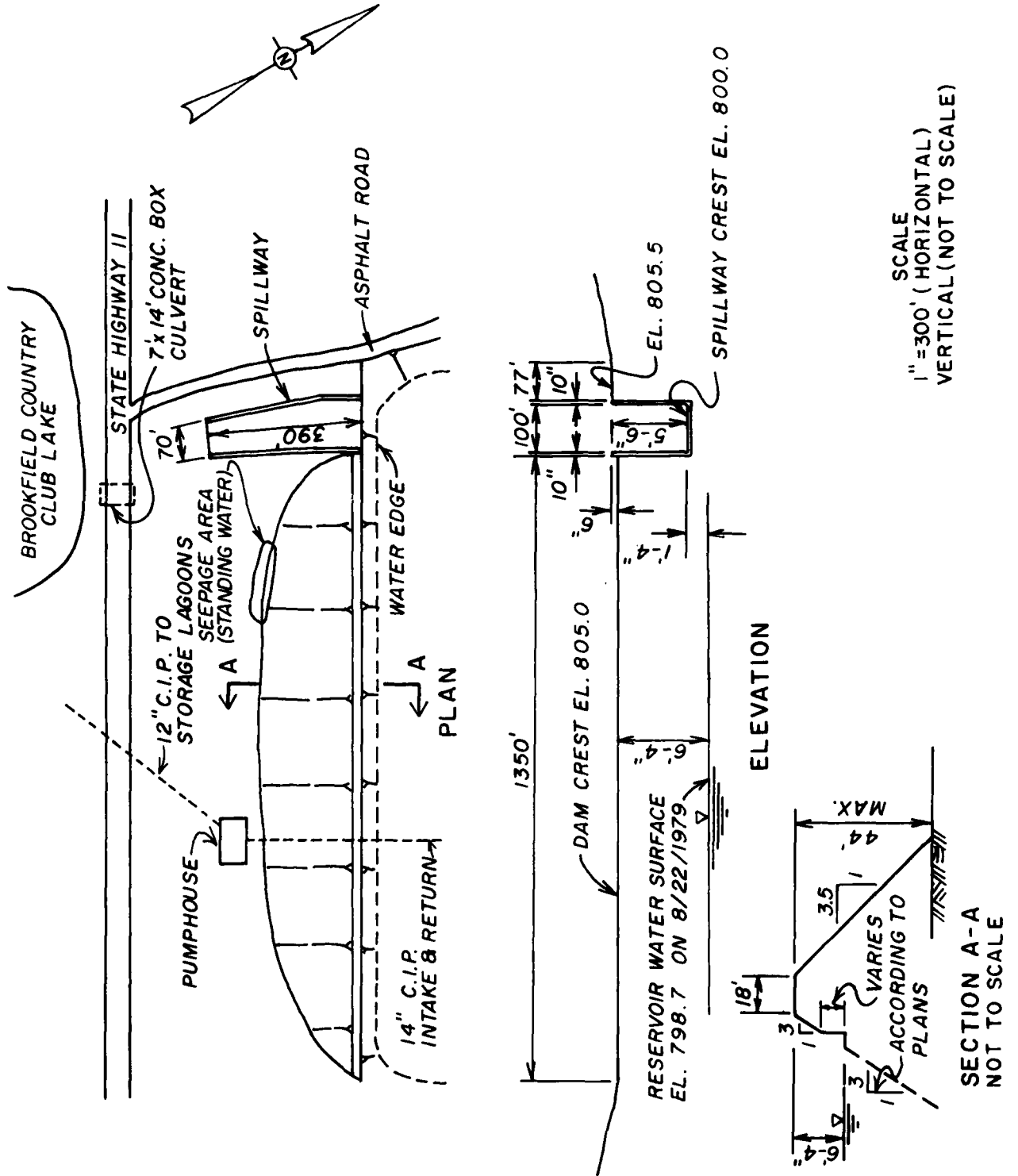

BROOKFIELD CITY DAM (MO.10181)  
 PLAN, ELEVATION & SECTION

SECTIONS  
WATERWORKS IMP

— FOR —

**BROOKFIELD**

E.T. ARCHER & CO  
CONSULTING ENGINEERS  
KANSAS CITY,

# STATIONS III & IV WORKS IMPROVEMENTS

FOR

## BROOKFIELD, MO.

ARCHER & COMPANY  
CONSULTING ENGINEERS  
KANSAS CITY, MO.

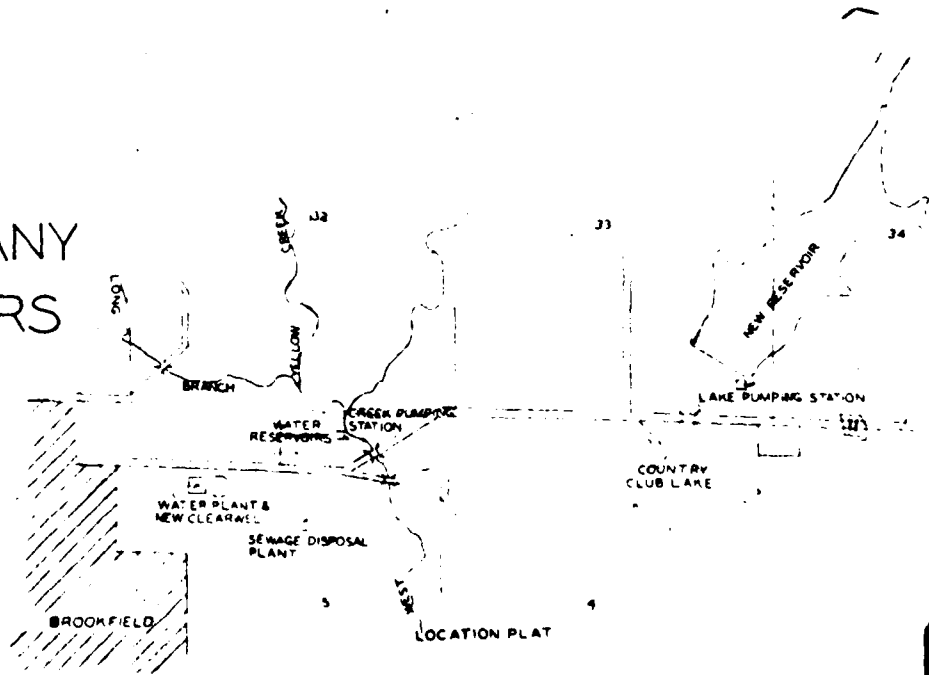

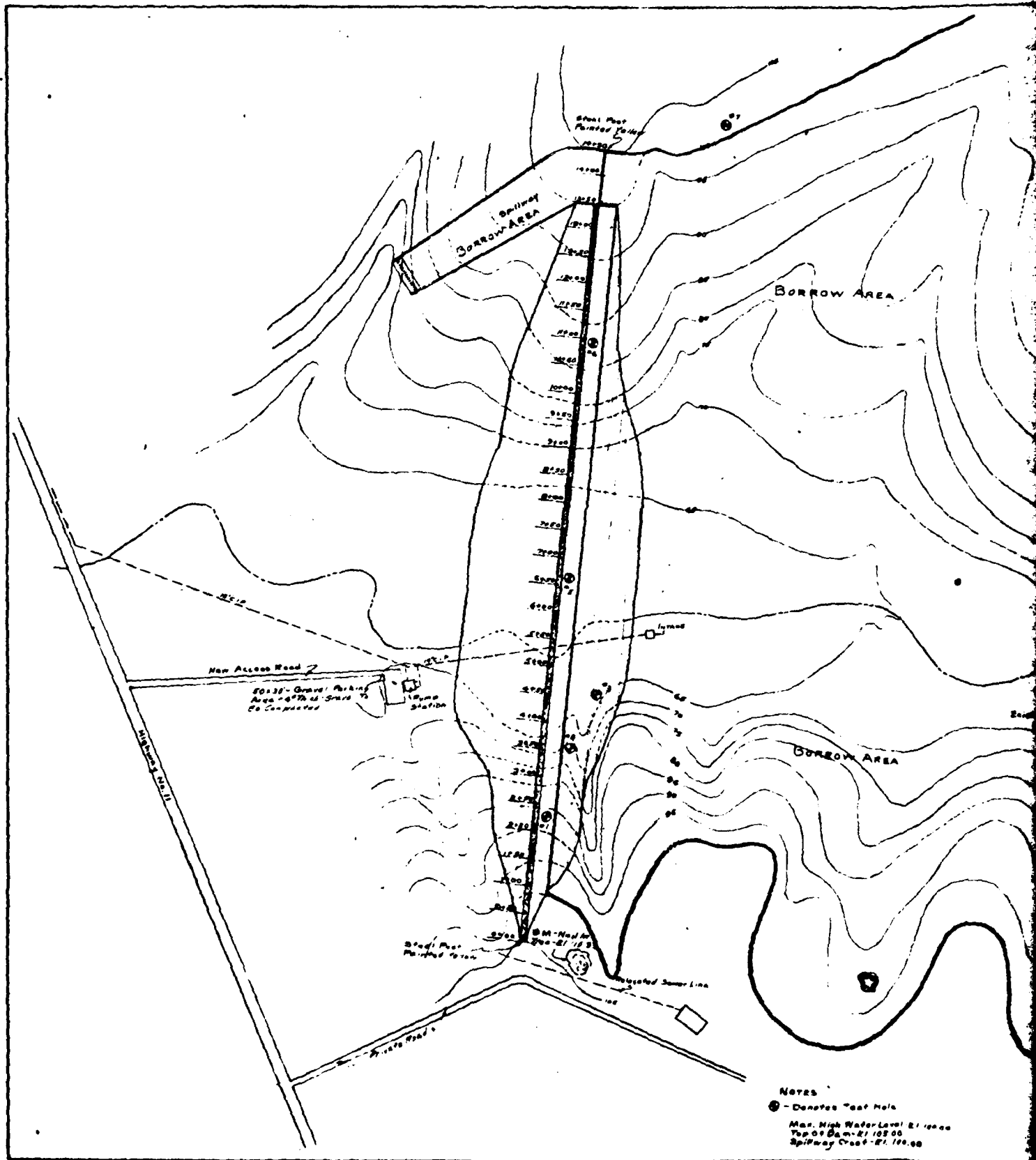

BORROW AREA

BORROW AREA

Existing Well To Be Plugged  
⑤

NOTE

Existing Wells To Be Plugged  
with Hardened Clay From The  
Borrower To The Existing  
Ground

NOTES

- - Denotes Test Hole
- Max. High Water Level 21.0000
- Top of Dam 21.12500
- Spillway Crest 21.10000

E. T. ARCHER & COMPANY	
CONSULTING ENGINEERS	
KANSAS CITY	MISSOURI
SECTION III	
RESERVOIR AREA PLAN	
WATERWORKS IMPROVEMENTS	
BROOKFIELD, MO.	
SHEET NO. 2	PLANNING NO. C-217

FINAL SURVEY PROFILE  
 DATE 1912  
 DRAWN BY J. H. [illegible]

ORIGINAL SURVEY PROFILE  
 DATE 1912  
 DRAWN BY J. H. [illegible]

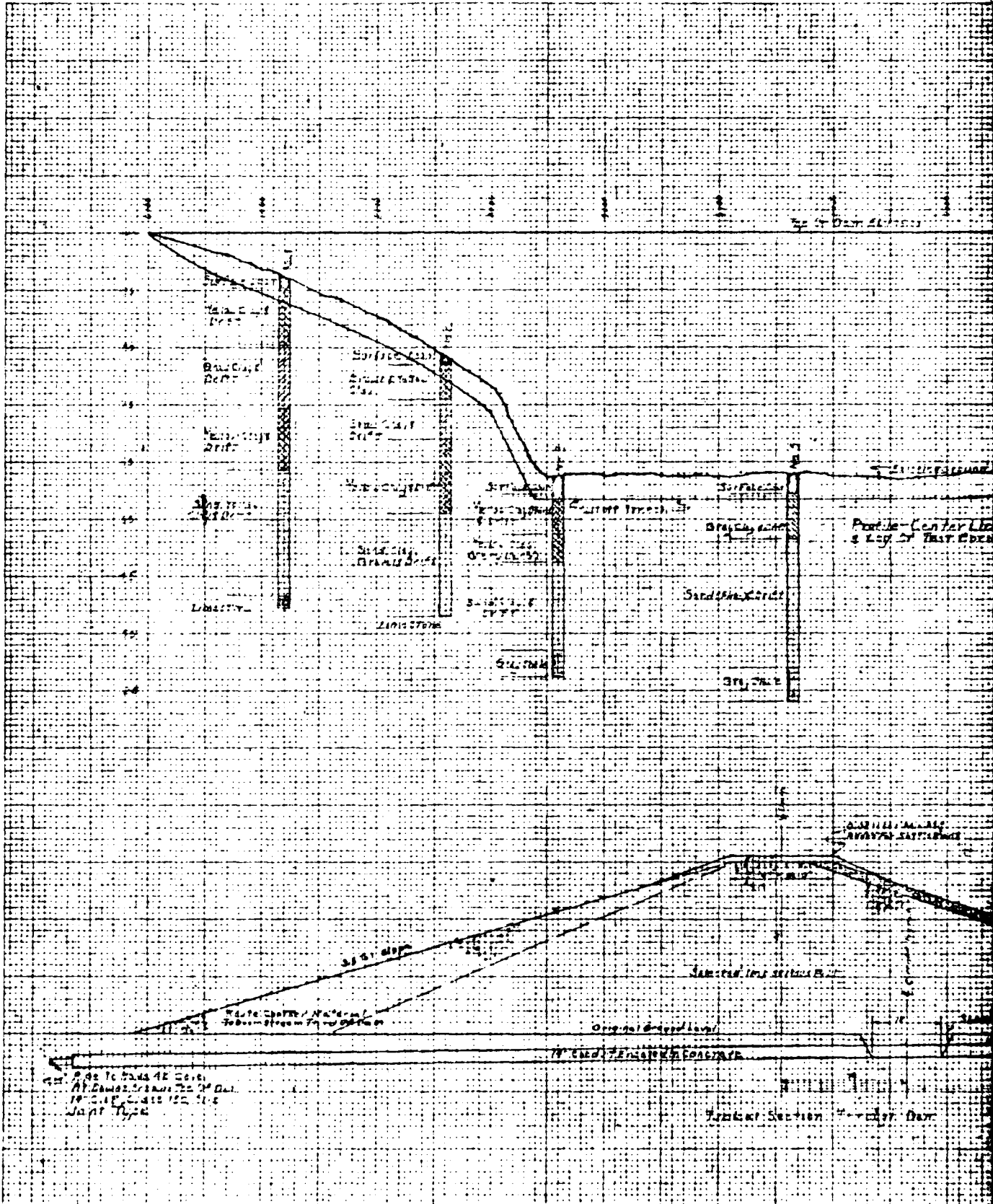

Profile - Center Line & Key of Test Cuts

Traverse Section



PLAN	DATE	BY	CHECKED
DESIGNED			
DRAWN			
CHECKED			
APPROVED			
BY			

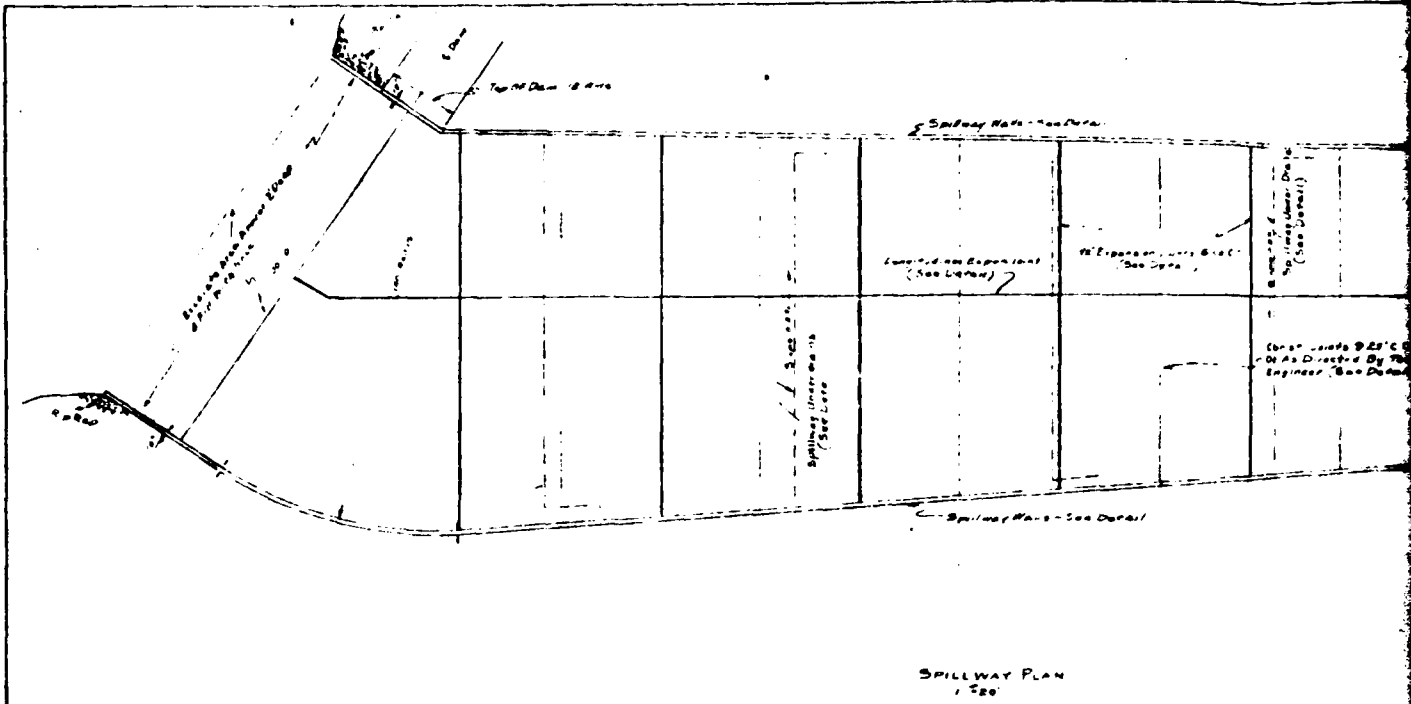

DATE	BY	CHECKED

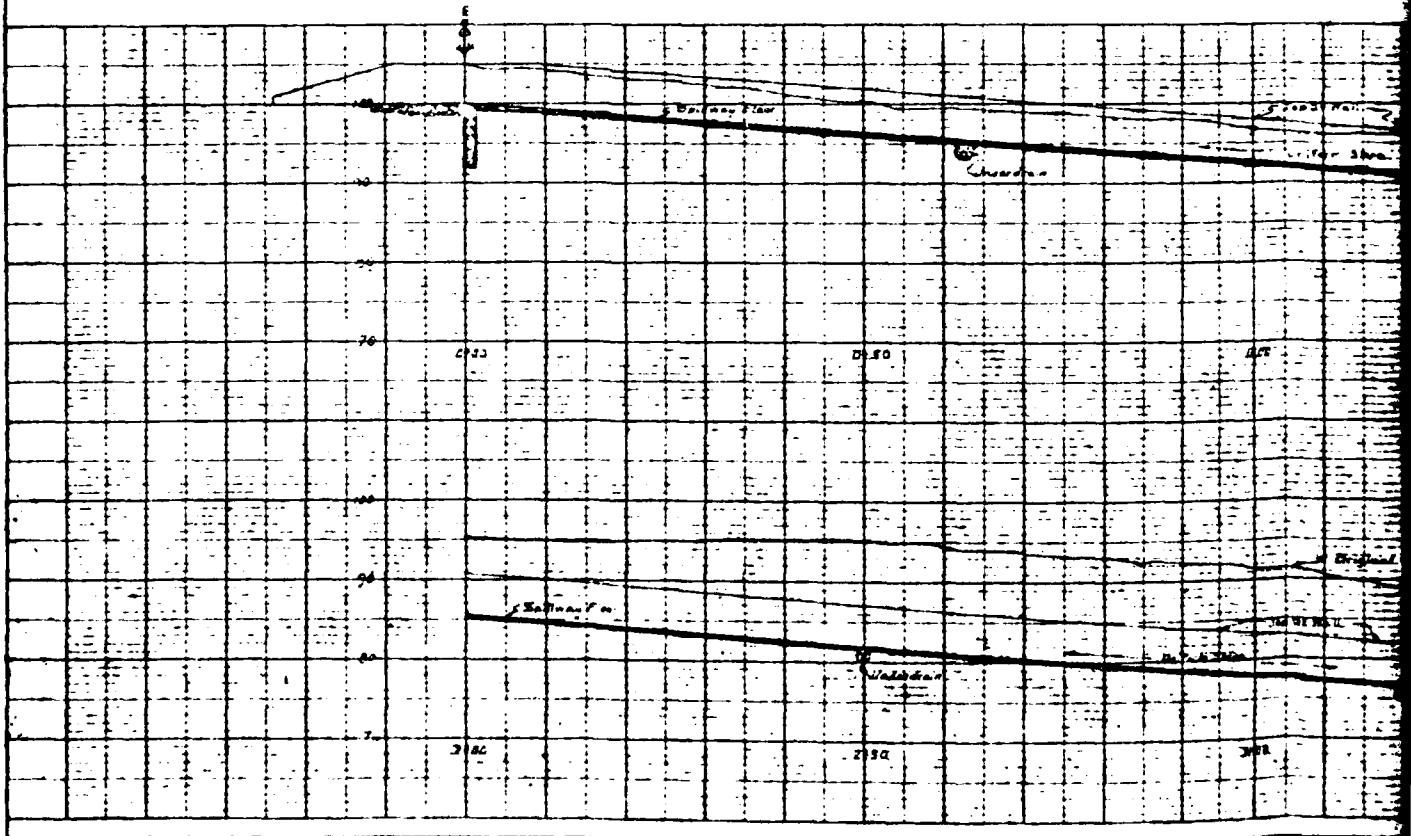

DATE FROM PEOPLE & ...  
 AND THE ...

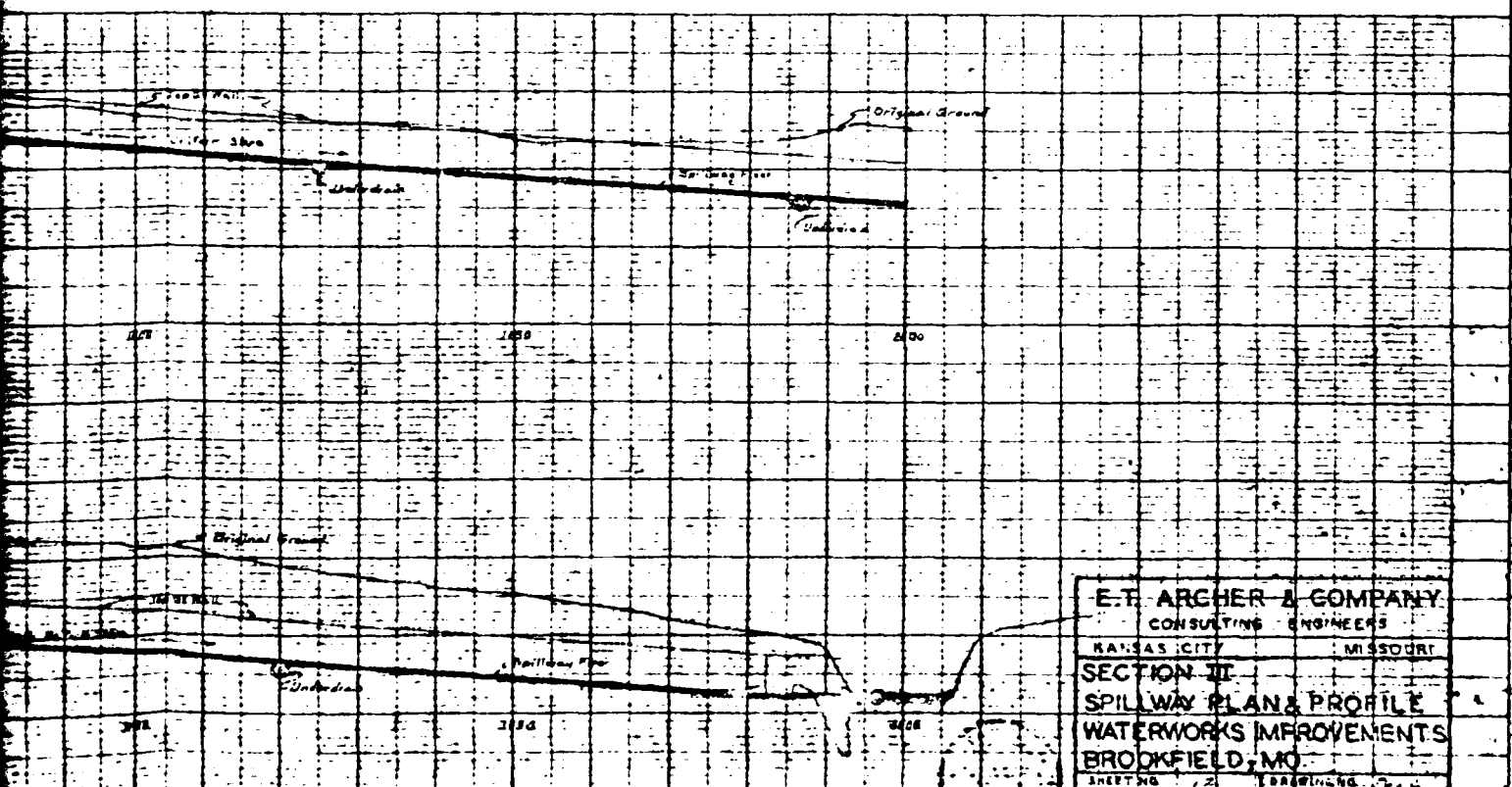
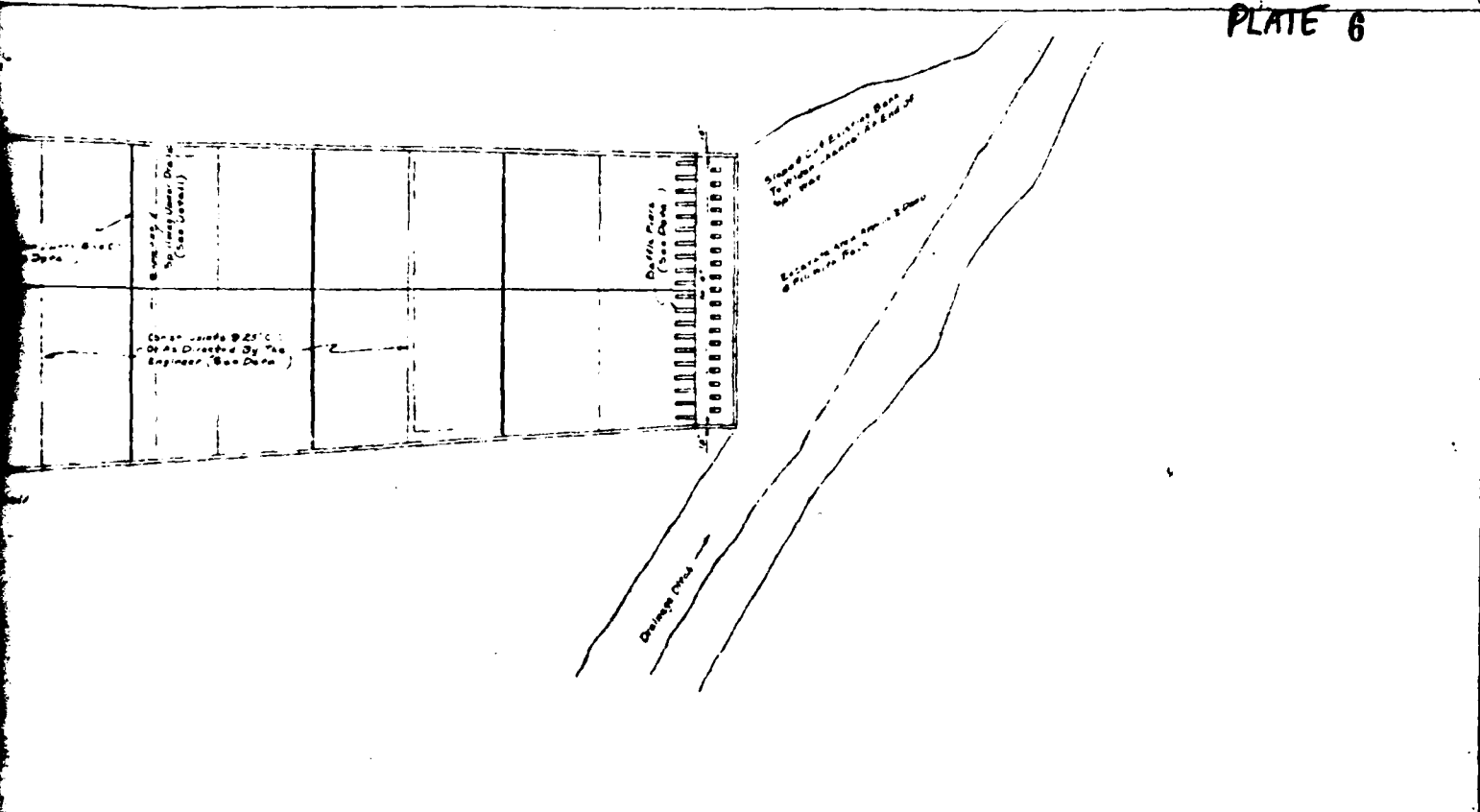

E. F. ARGHER & COMPANY  
 CONSULTING ENGINEERS  
 KANSAS CITY MISSOURI  
 SECTION III  
 SPILLWAY PLAN & PROFILE  
 WATERWORKS IMPROVEMENTS  
 BROOKFIELD, MO.  
 SHEET NO. 2

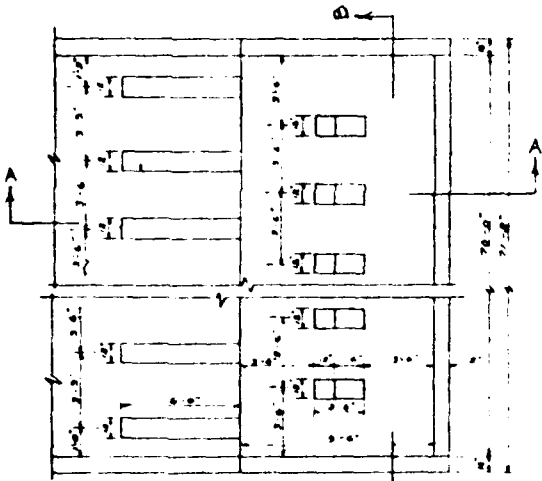

SPILLWAY TAILFACE - PLAN  
16'-11 1/2"

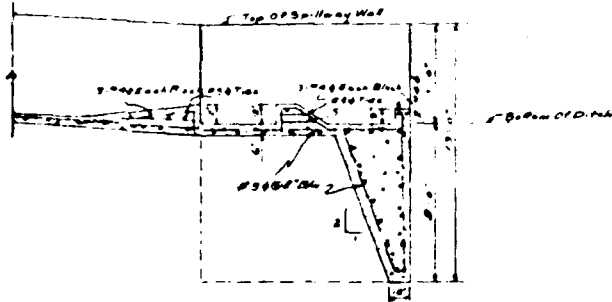

A-A  
16'-11 1/2"

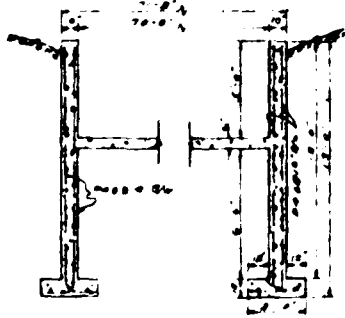

B-B  
16'-11 1/2"

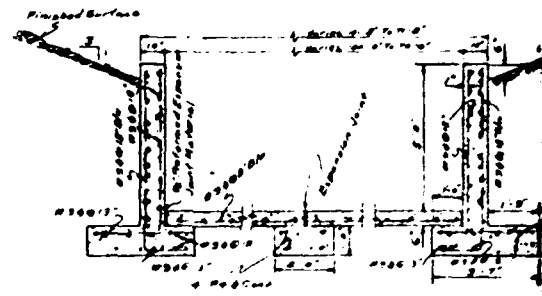

TYPICAL SPILLWAY CROSS SECTION ON  
32'-10 1/2"

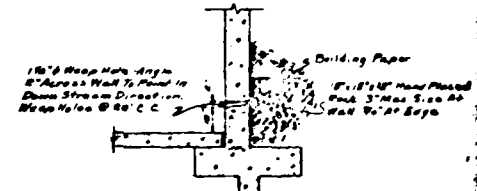

WEEP HOLE DETAIL  
16'-11 1/2"

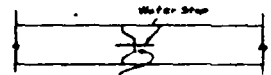

CONSTRUCTION JOINT DETAIL - WALLS & FLOOR SLAB  
16'-11 1/2"

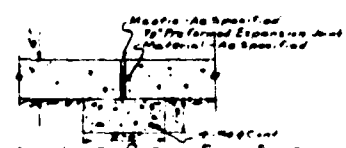

EXPANSION JOINTS DETAIL - FLOOR SLAB  
16'-11 1/2"

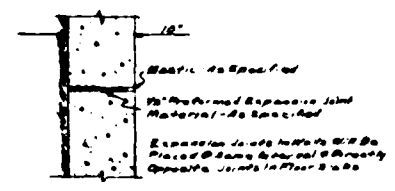

EXPANSION JOINTS DETAIL - WALLS  
16'-11 1/2"

PLATE 7

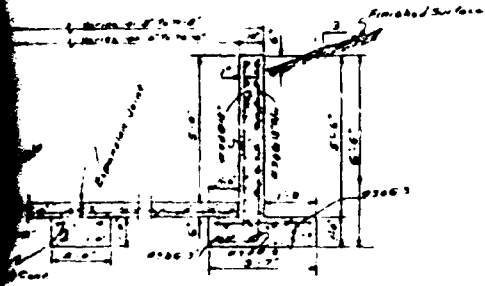

SPILLWAY CROSS SECTION  
No. 10'

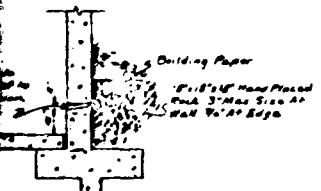

WEDGE HOLE DETAIL  
No. 11'

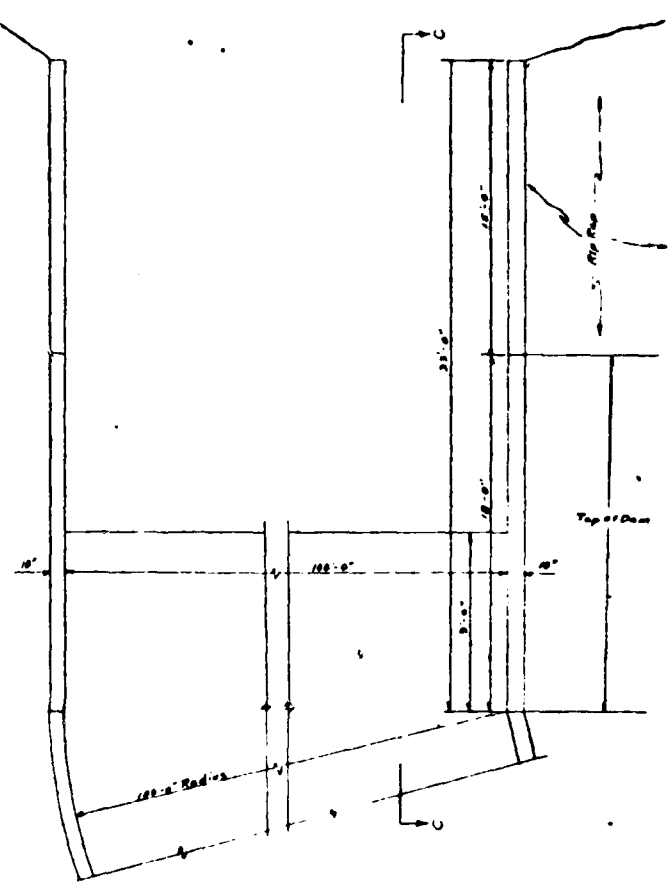

PLAN SPILLWAY CREST  
No. 12'

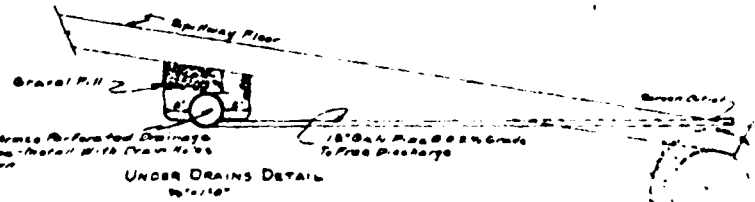
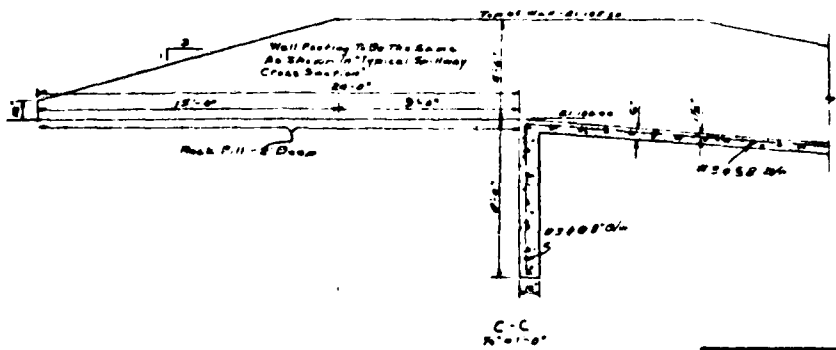

UNDER DRAINS DETAIL  
No. 13'

Material - As Specified  
 Expansion Joints in Walls Will Be Placed @ Same General @ Groutly  
 Expansion Joints in Floor Slabs  
 WALLS

<b>E. T. ARCHER &amp; COMPANY</b> CONSULTING ENGINEERS KANSAS CITY MISSOURI	
<b>SECTION III</b> SPILLWAY DETAILS WATERWORKS IMPROVEMENTS BROOKFIELD, MO.	
SHEET NO.	DRAWING NO. 527

2

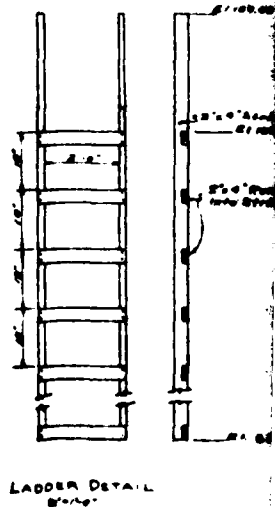
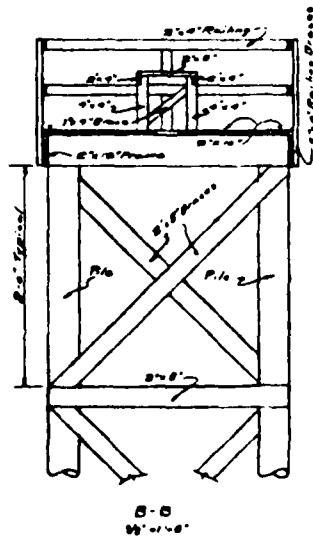
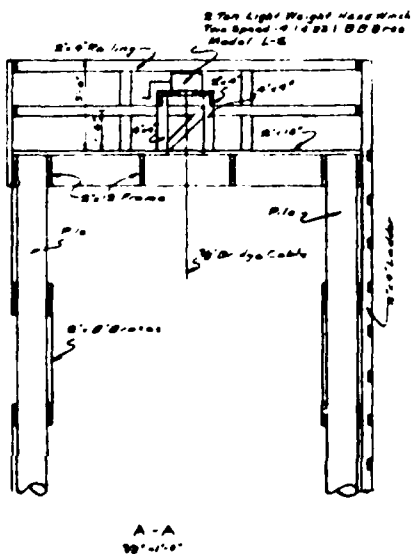
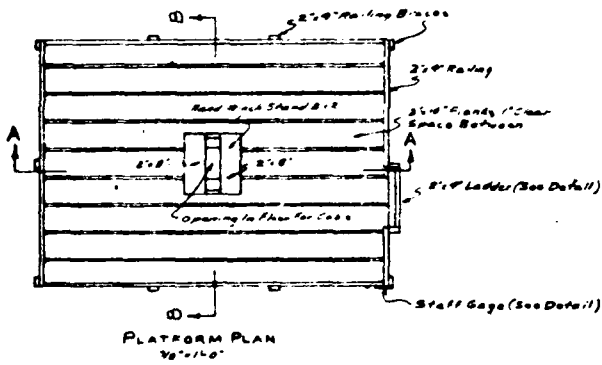
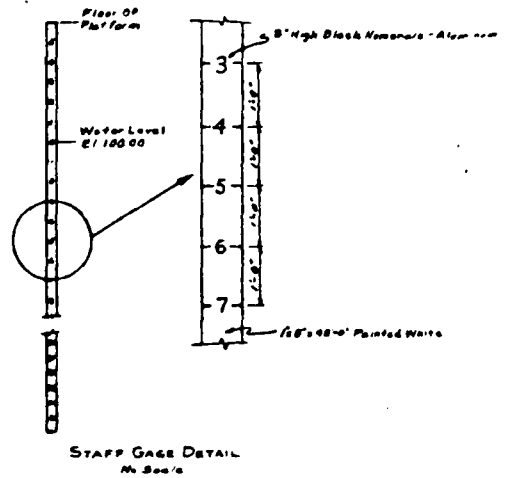
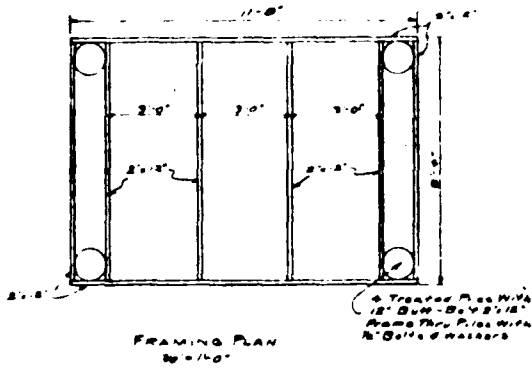

5" High Black Nipples - Alum. ...

4" x 4" x 1/2" Painted White

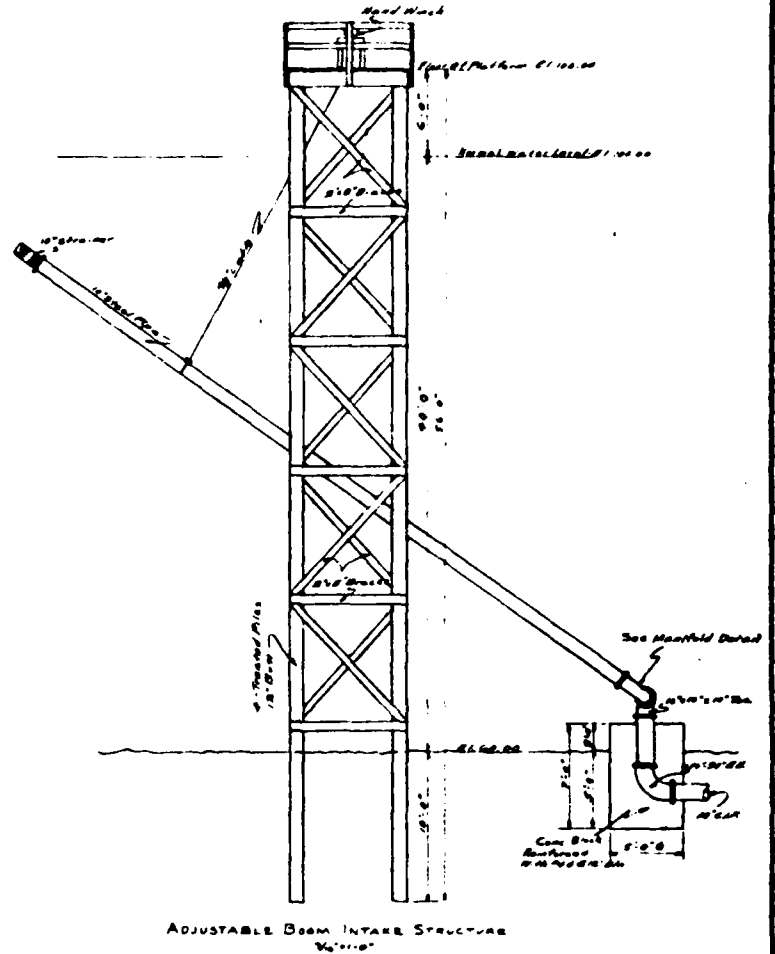

ADJUSTABLE BOOM INTAKE STRUCTURE  
No. 1110

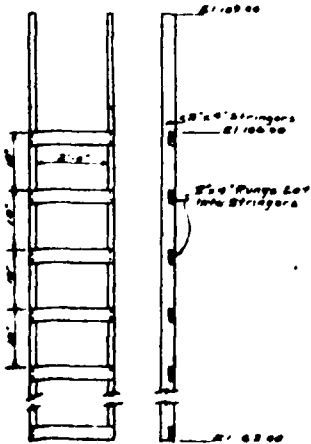

LADDER DETAIL  
No. 1110

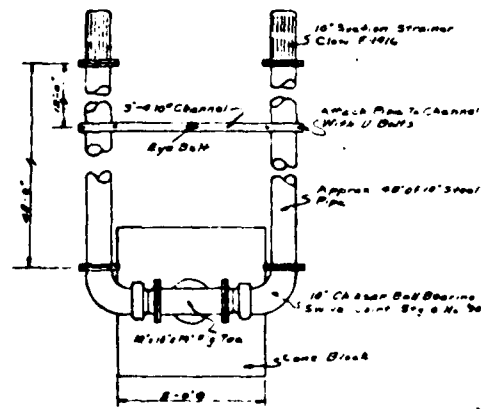

INTAKE MANIFOLD DETAIL  
No. 1110

<b>E. T. ARCHER &amp; COMPANY</b>	
CONSULTING ENGINEERS	
KANSAS CITY	MISSOURI
<b>SECTION IV</b>	
<b>ADJUSTABLE INTAKE DETAILS</b>	
<b>WATERWORKS IMPROVEMENTS</b>	
<b>BROOKFIELD, MO.</b>	
SHEET NO. 25	DRAWING NO. 5334

2

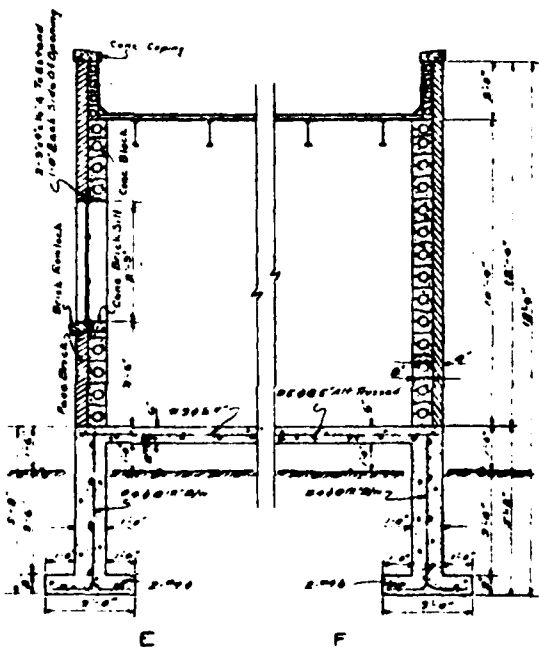
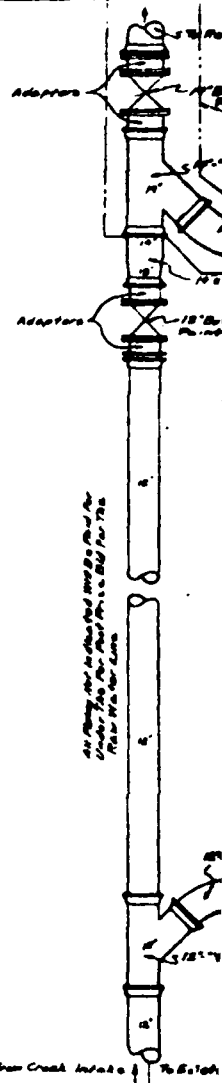
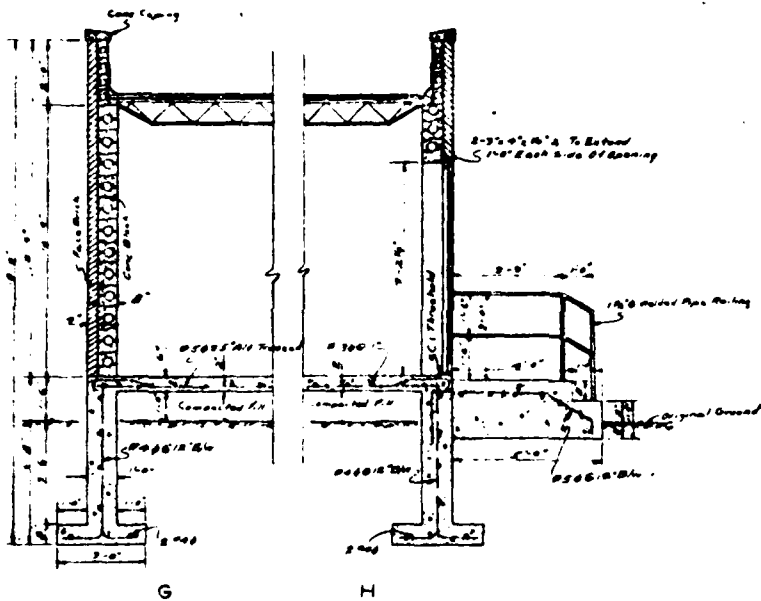

TYPICAL WALL SECTIONS  
16" WALL

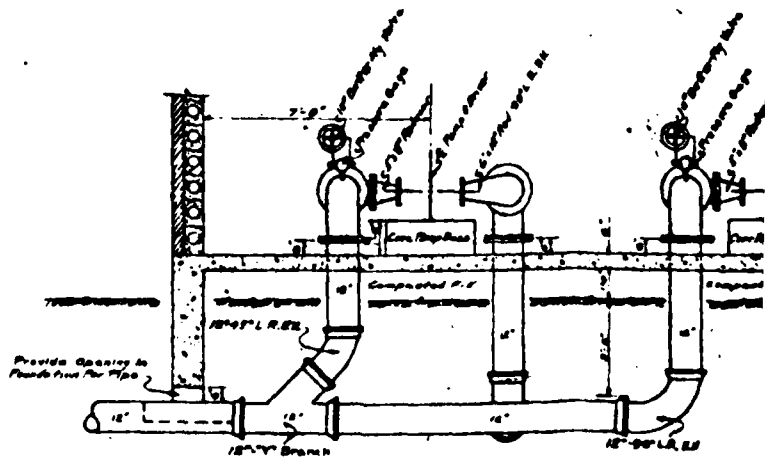

I-I  
16" WALL

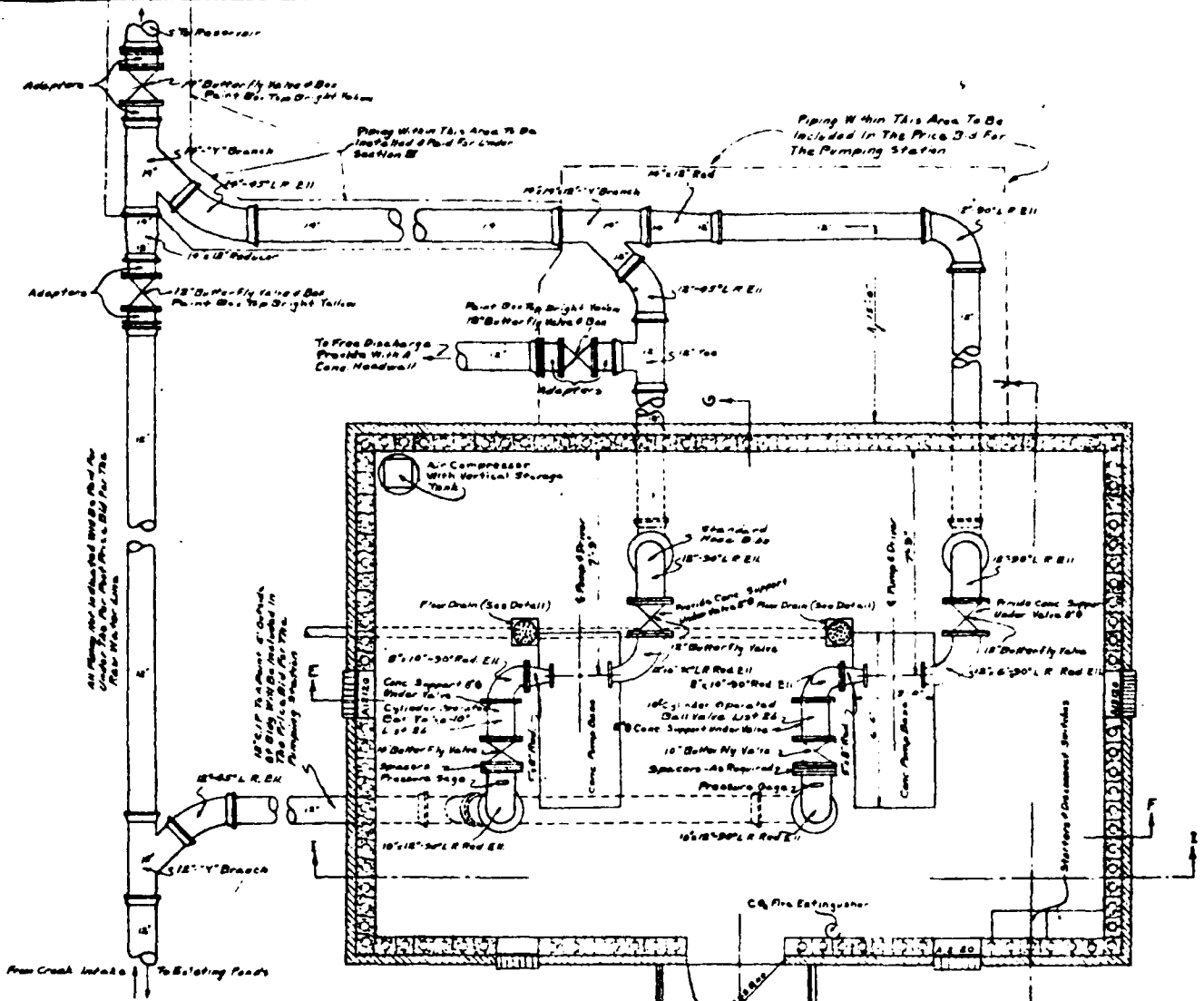

EQUIPMENT PLAN

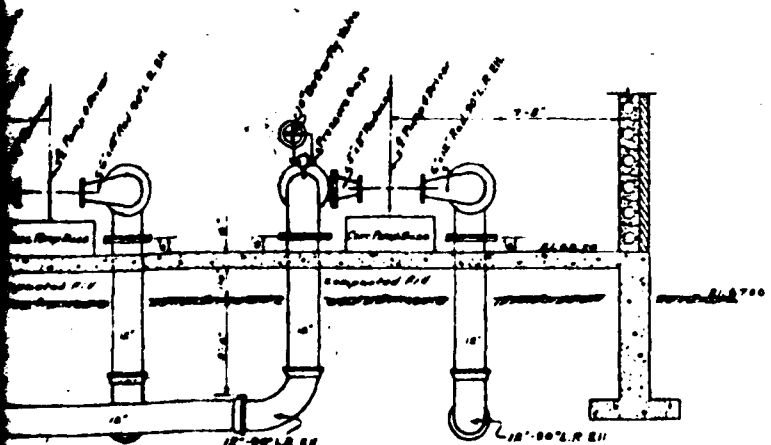

I-I

E. T. ARCHER & COMPANY	
CONSULTING ENGINEERS	
KANSAS CITY	MISSOURI
SECTION IV	
LAKE PUMPING STATION	
WATERWORKS IMPROVEMENTS	
BROOKFIELD, MO.	
DWG. NO. 26	DRAWING NO. 5995

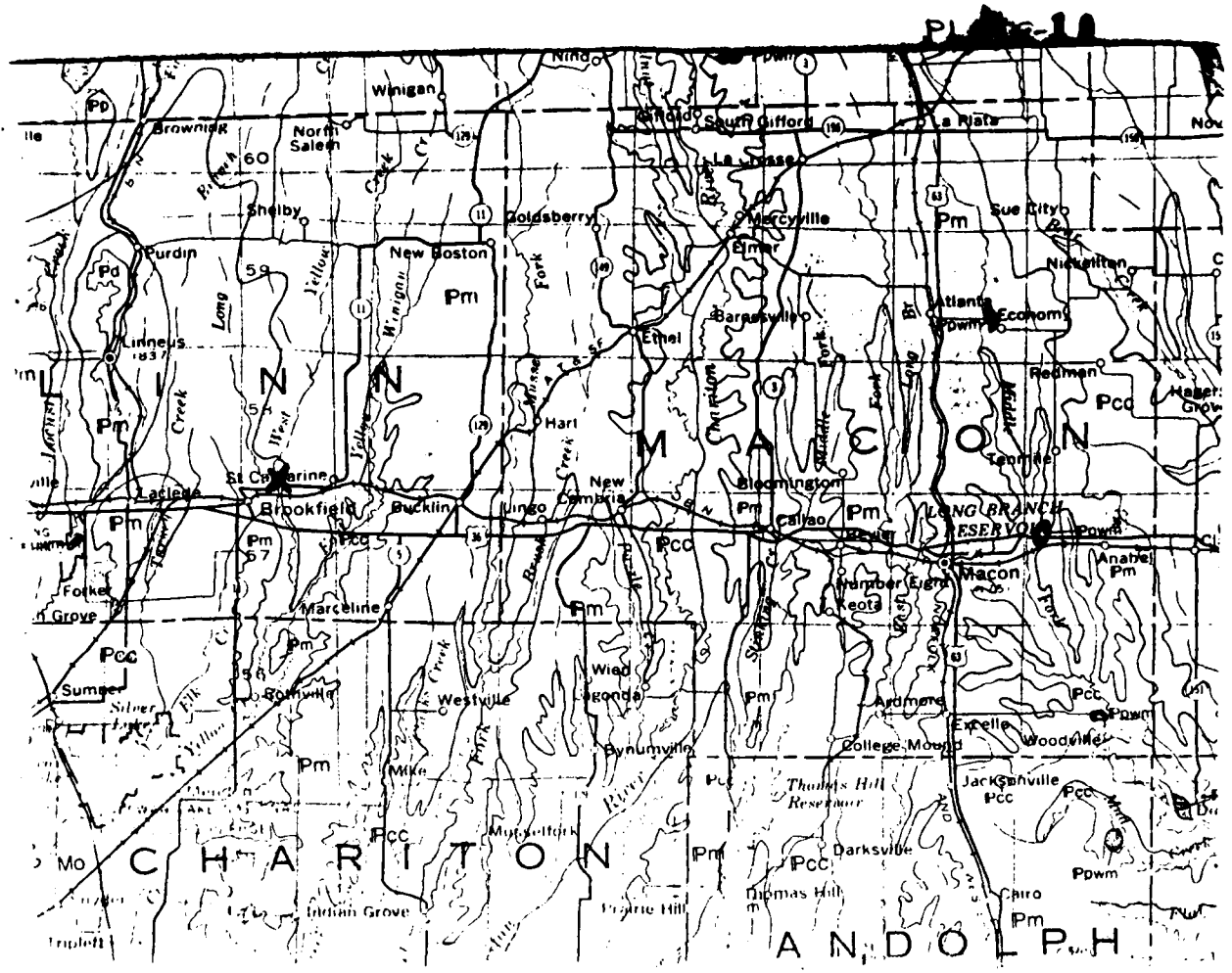

PENNSYLVANIAN { IPm - MARMATON GROUP  
 IPcc - CHEROKEE GROUP,  
 CABANISS SUBGROUP

X - LOCATION OF DAM, MO. 10181

REFERENCE:  
 GEOLOGIC MAP OF MISSOURI  
 MISSOURI GEOLOGIC SURVEY  
 1979

GEOLOGIC MAP  
 OF  
 LINN COUNTY  
 AND  
 ADJACENT AREA

From TM 5-809-10 NAVFAC P-355 AFM 88-3, Chapter 13, April 1973

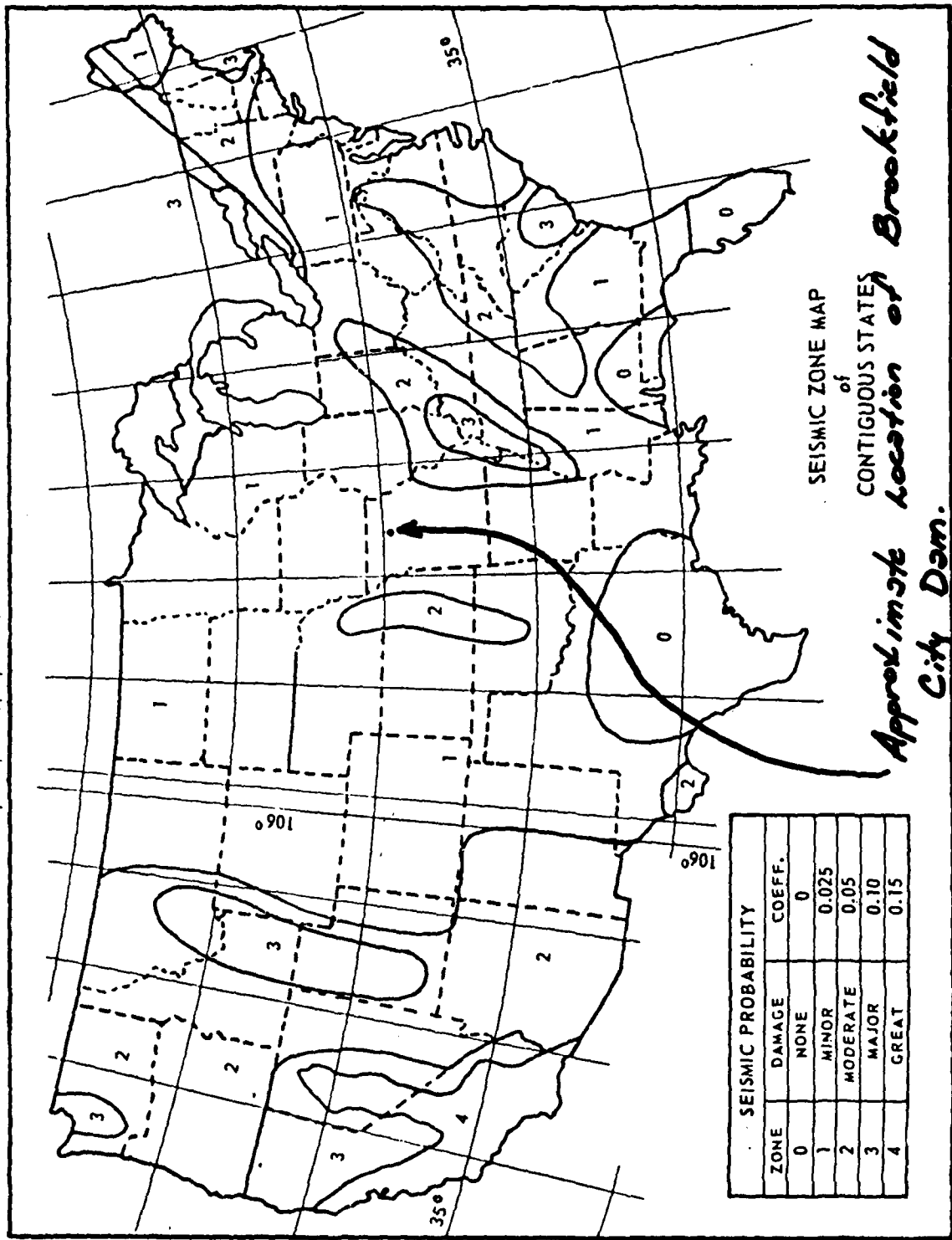

APPENDIX A

PHOTOGRAPHS TAKEN DURING INSPECTION

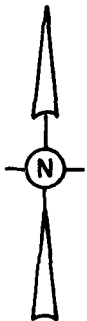
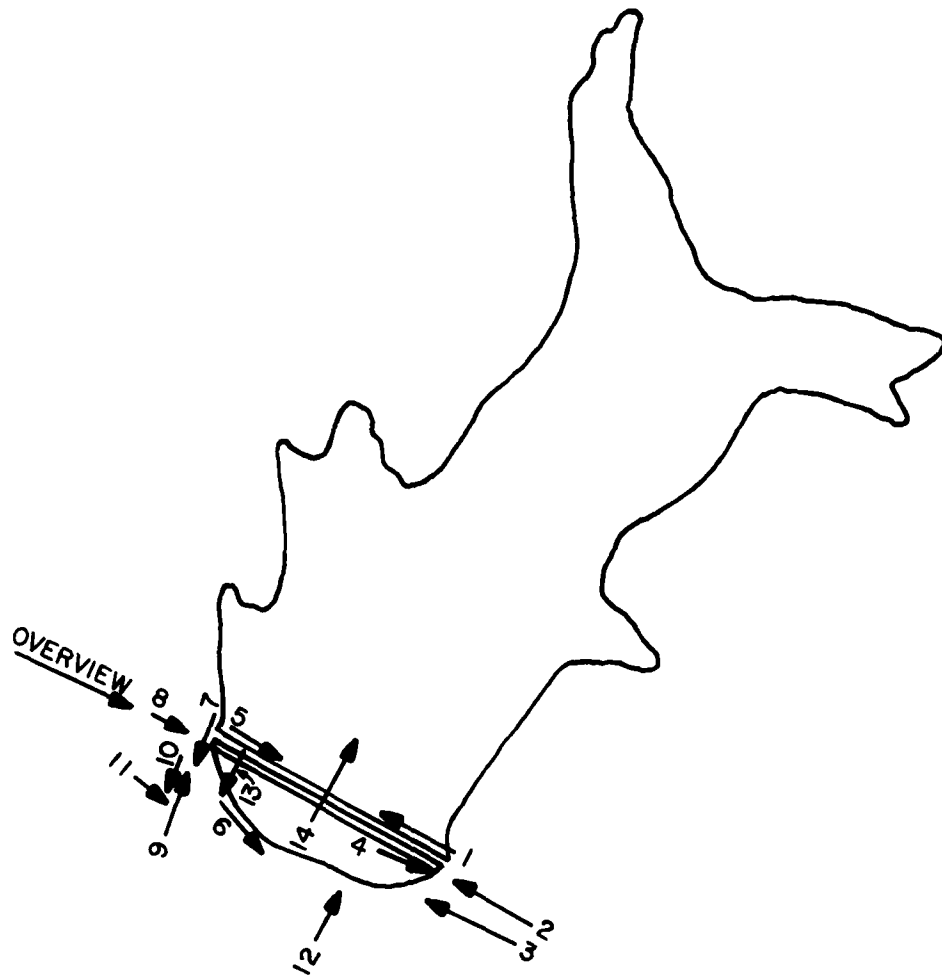

PHOTO INDEX  
FOR  
BROOKFIELD CITY DAM

Brookfield City Dam



Photo 1

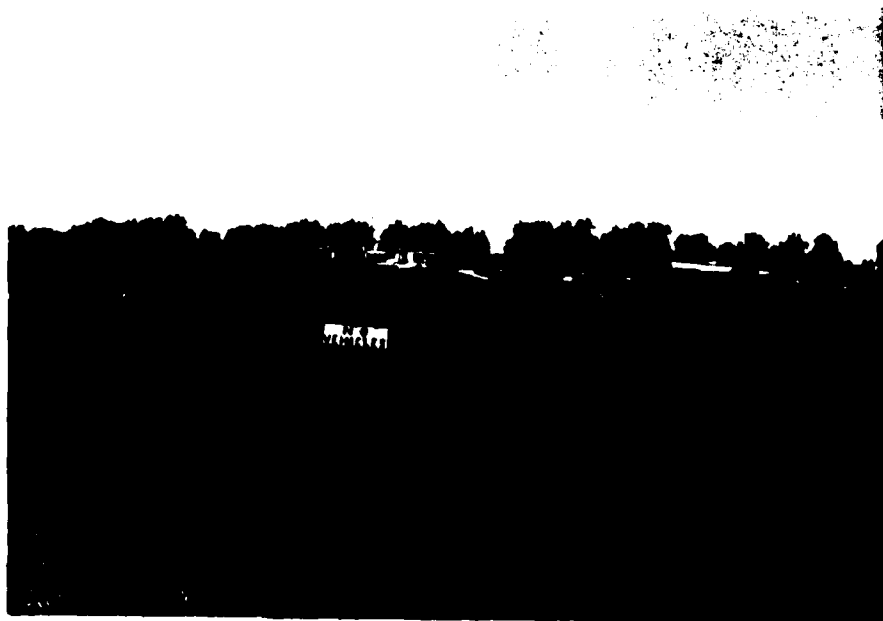

Photo 2

Brockfield City Dam



Photo 3



Photo 4

Brookfield City Dam



Photo 5



Photo 6

Brookfield City Dam



Photo 7



Photo 8

Brookfield City Dam



Photo 9



Photo 10

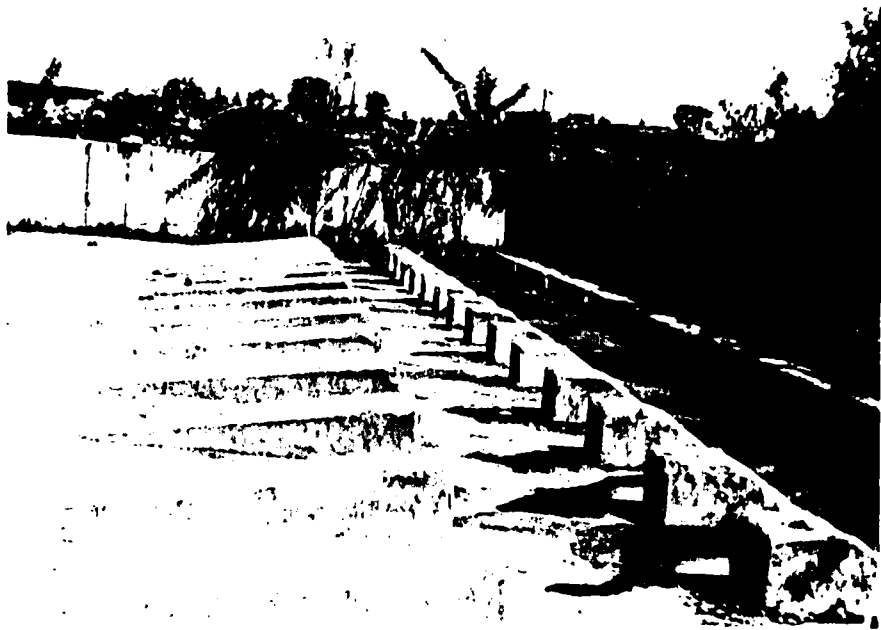

Photo 11

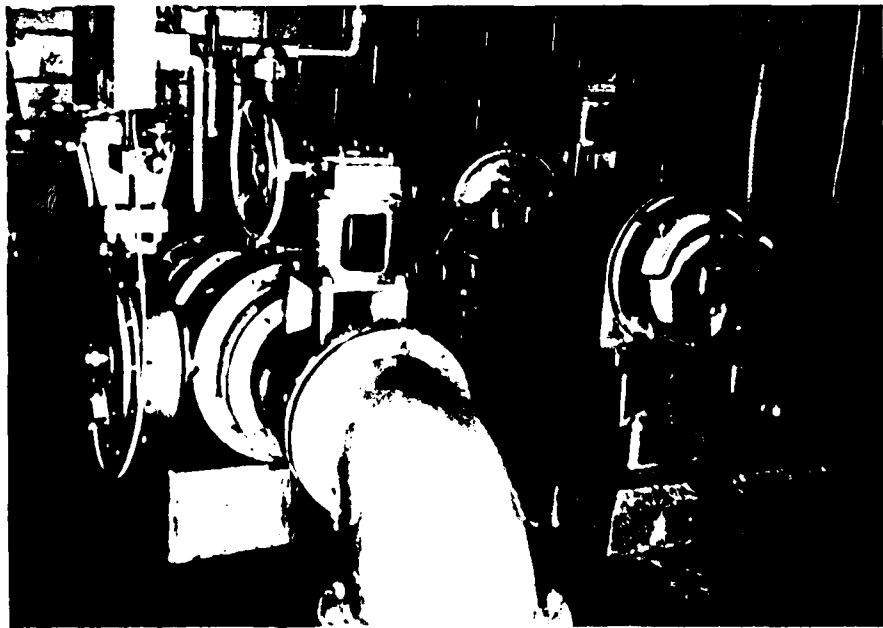

Photo 12



Photo 13



Photo 14

APPENDIX B  
HYDROLOGIC COMPUTATIONS

B-1

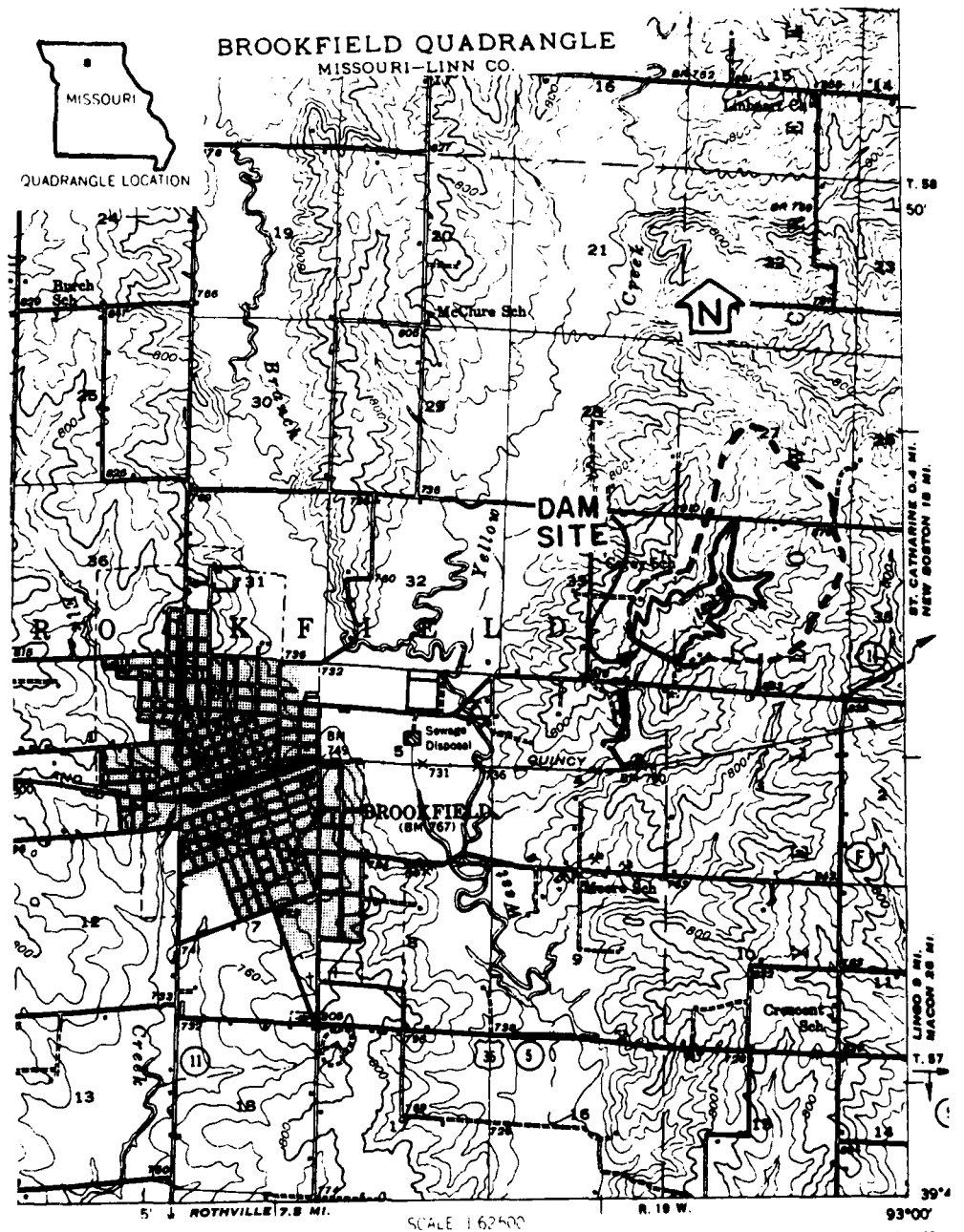

DRAINAGE BOUNDARY - - - - -

BROOKFIELD CITY DAM (MO 10181)  
DRAINAGE BASIN

PRC ENGINEERING CONSULTANTS, INC.

LEAK SAFETY INSPECTION

SHEET NO. 1 OF

PROPOSED CITY DAM (# 10181)

JOB NO. 1240

SPILLWAY AND OVERTOPPING RATING CURVE

BY PAW DATE 7-5

KTB

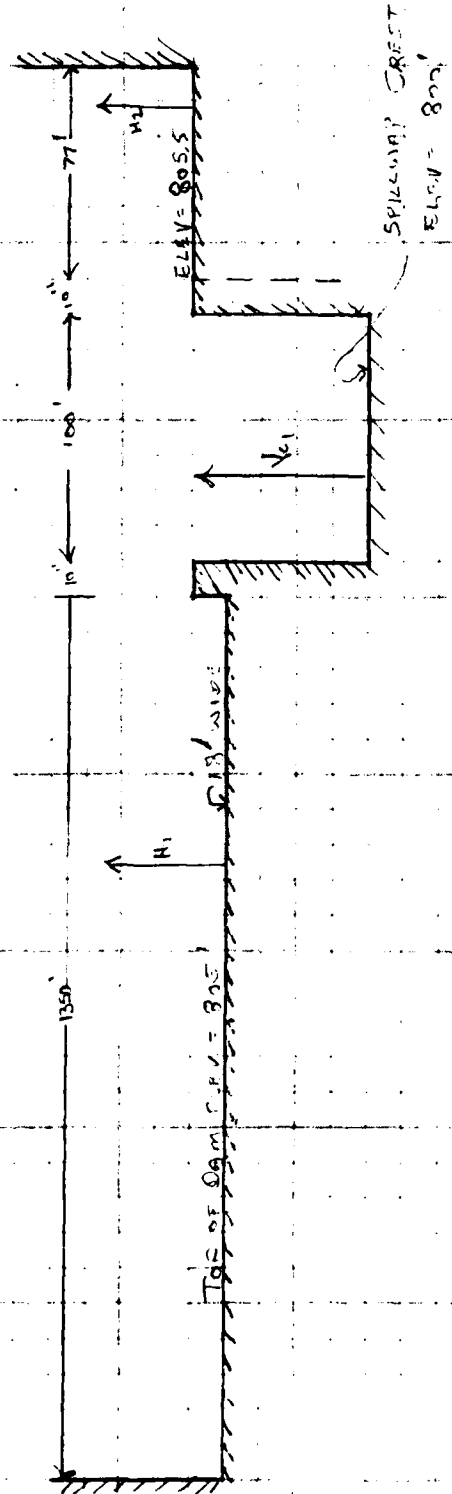

U.S. ELEV.	$P_1$	$V_1 = \frac{Q_1}{A_1}$	$\frac{Q_1^2}{g A_1^3}$	$\frac{Q_1^2}{A_1^3}$	$H_1$	$C_1$	$L_1$	$Q_1^2 = \frac{Q_1^2}{g C_1 H_1^3}$	$H_2$	$C_2$	$L_2$	$Q_2 = \frac{Q_2^2}{g C_2 H_2^3}$	$Q_2 = Q_1 \frac{H_1}{H_2}$
800		0											0
801	67	0.67	484	311									311
802	133	1.33	659	870									870
804	267	2.67	1927	2475									2475
805	333	3.33	1035	3446	0								3446
805.5	367	3.67	1097	3787	5	2.70	1350	1289	0		7867	0	5278
806	400	4.0	1185	4540	1.0	2.63		3551	0.5	3.70		75	8166
807	467	4.67	1726	5725	2.0	2.63		10042	1.5	2.63		380	16147

D-3

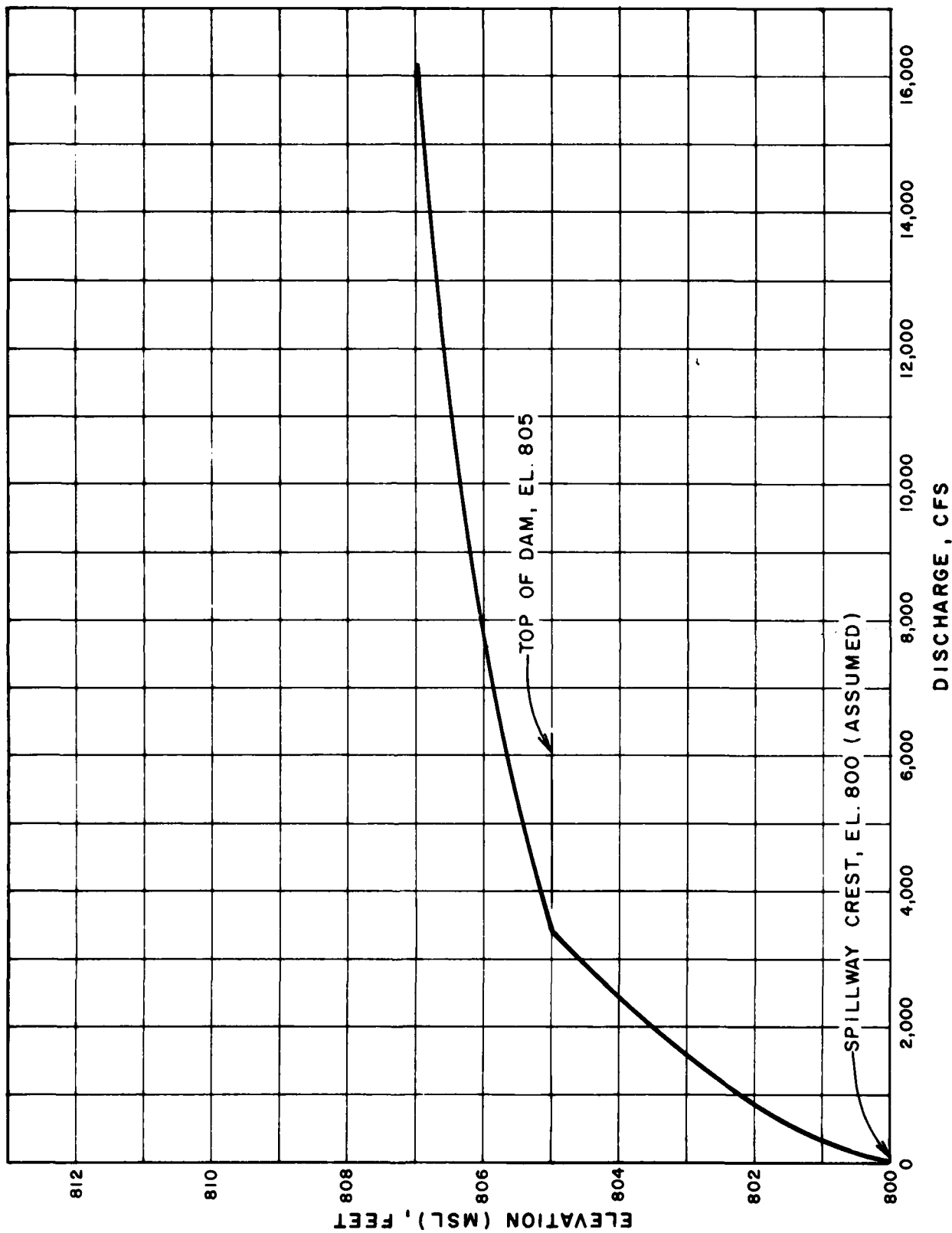

BROOKFIELD CITY DAM (MO. 10181)  
SPILLWAY AND OVERTOP RATING CURVE  
B-4

DAIRY SAFETY INSPECTION SHEET NO. 1 OF  
 BROOKFIELD CITY DAM (# 10181) JOB NO. 1240  
 RESERVOIR AREA CAPACITY BY Paul KLB DATE 10

BROOKFIELD CITY DAM  
 RESERVOIR AREA CAPACITY

ELEVATION MSL (ft)	RESERVOIR SURFACE AREA (ACRES)	INCREMENTAL VOLUME (ACFT)	TOTAL VOLUME (ACFT)	REMARKS
765	0	0	0	ESTIMATED STREAMBED ELEVATION AT DAM
780	49	245	245	
785	66	286	531	
800	118	1361	1892	SPILLWAY CREST
805	141	647	2539	TOP OF DAM
820	209	2608	5147	

$$\Delta V_1 = \frac{15}{3}(49) = 245$$

$$\Delta V_2 = \frac{5}{3}(66+49 + \sqrt{66 \times 49}) = 286$$

$$\Delta V_3 = \frac{13}{3}(118+66 + \sqrt{118 \times 66}) = 1361$$

$$\Delta V_4 = \frac{5}{3}(141+118 + \sqrt{141 \times 118}) = 647$$

$$\Delta V_5 = \frac{15}{3}(209+141 + \sqrt{209 \times 141}) = 2608$$

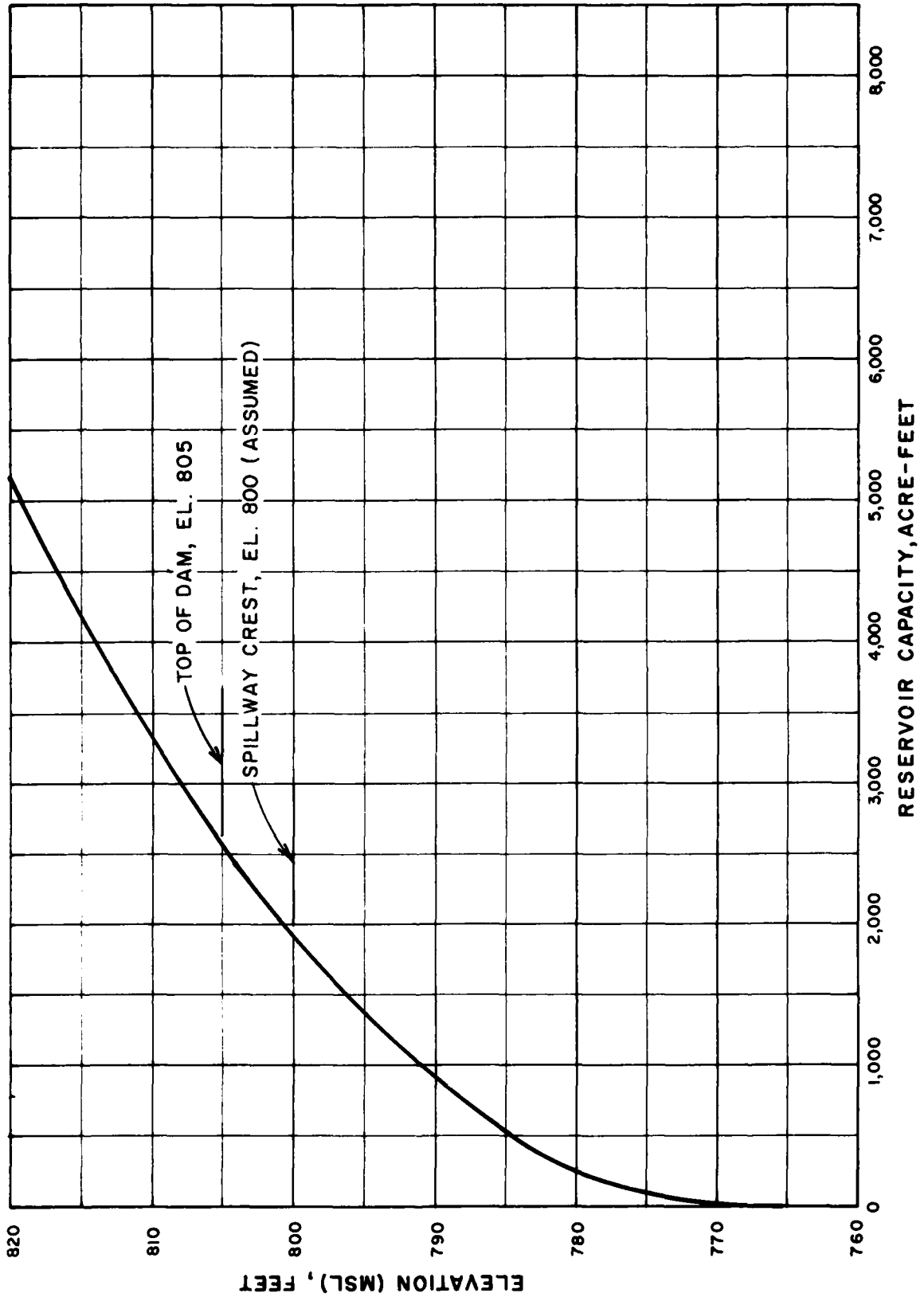

B-6

BROOKFIELD CITY DAM (MO.10181)  
RESERVOIR CAPACITY CURVE

Dam Safety Inspection

SHEET NO. 1 OF

MISSOURI Dam (MO. 10181)

JOB NO. 1240-001

PROBABLE MAXIMUM PRECIPITATION

BY TRW / KLB DATE 8-17-77

DAM # MO 10181

DETERMINATION OF PMP

1.) DETERMINE DRAINAGE AREA OF BASIN

D.A. - 807 AC

2.) DETERMINE PMP INDEX RAINFALL  
(200 SQ.MI., 24 HR. DURATION)

LOCATION OF CENTROID OF BASIN

LONG 93° 00' 53"

LAT 39° 48' 11"

⇒ PMP = 24.25

3.) DETERMINE BASIN RAINFALL IN TERMS OF

PERCENTAGE OF PMP INDEX RAINFALL

FOR VARIOUS DURATIONS:

LOCATION LONG 93° 00' 53"

LAT 39° 48' 11"

⇒ ZONE 7

DURATION (HR)	PERCENT OF INDEX RAINFALL	TOTAL RAINFALL (IN)	RAINFALL INCREMENTS	DURATION OF INCREMENTS
6	100	24.25	24.25	6
12	120	29.1	4.85	6
24	130	31.52	2.42	12

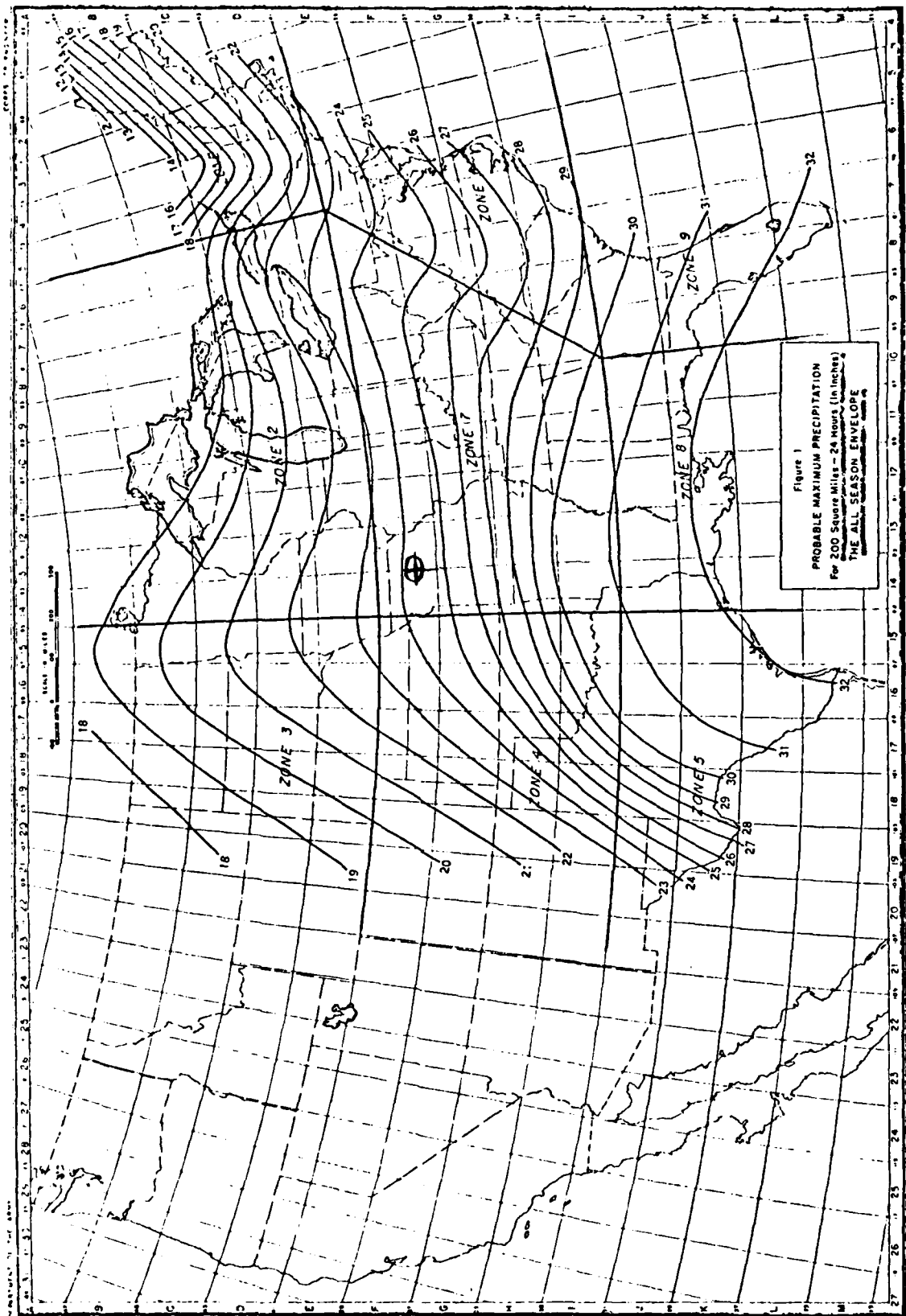

MISSOURI DAM (MO. 10181)

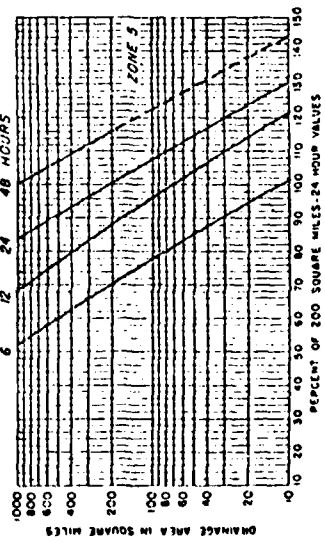
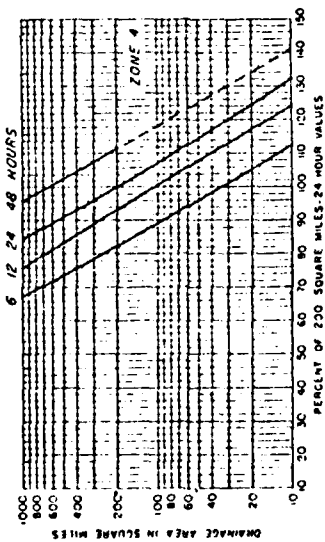
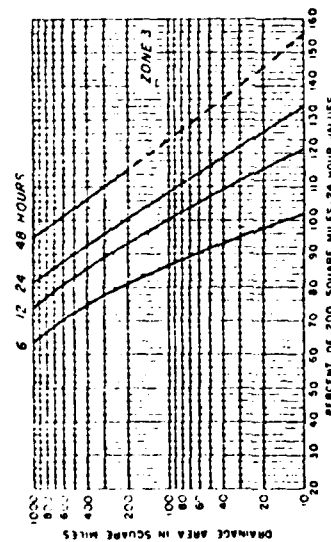
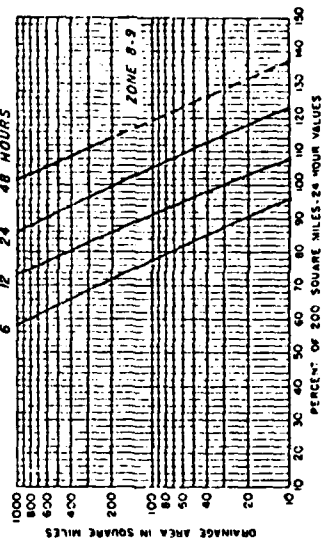
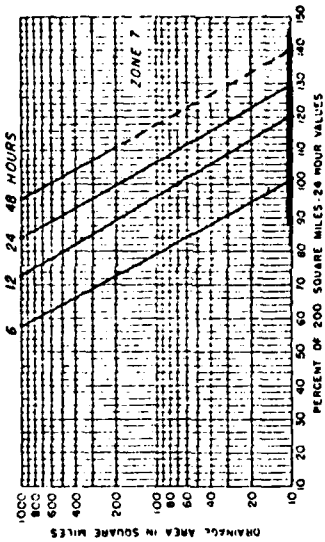
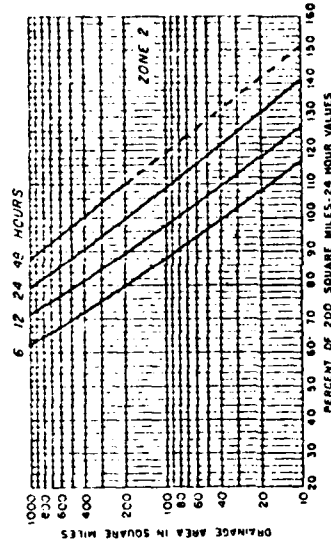
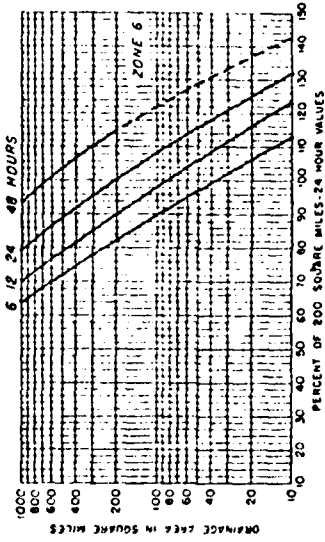
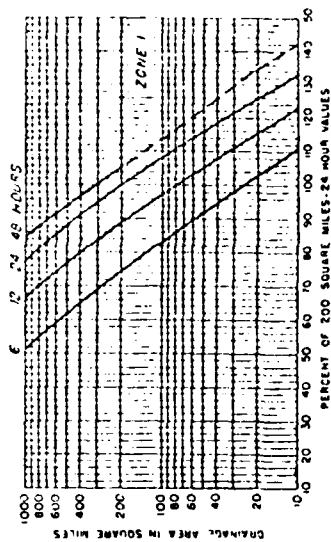

FIGURE 2  
SEASONAL VARIATION  
DEPTH-AREA-DURATION RELATIONSHIPS  
Percentage to be applied to 200 square miles  
24 hour probable maximum precipitation values  
for: THE-ALL SEASON ENVELOPE

DAM SAFETY INSPECTION - MISSOURI

SHEET NO. 1 OF

BROOKFIELD CITY DAM (#10181)

JOB NO. 1240-001-1

UNIT HYDROGRAPH PARAMETERS

BY KLB  
(PAW) DATE 8-20

1. DRAINAGE AREA,  $A = 702 \text{ ACRES} = 1.1 \text{ SQ. MI.}$
2. LENGTH OF STREAM  $= 0.98" \times \frac{62500}{12} = 2500 \text{ FT} = 0.47 \text{ MI.}$
3. ELEVATION AT DRAINAGE DIVIDE ALONG THE LONGEST STREAM  $H_1 = 870 \text{ FT}$
4. RESERVOIR ELEVATION AT THE SPILLWAY CREST,  $H_2 = 800 \text{ FT}$   
(ASSUMED)
5. DIFFERENCE IN ELEVATION,  $\Delta H = H_1 - H_2 = 870 - 800 = 70 \text{ FT}$
6. AVERAGE SLOPE OF STREAM  $= \frac{\Delta H}{L} = \frac{70}{2500} = 2.8\%$
7. TIME OF CONCENTRATION
  - a) BY KIRPICH FORMULA:
 
$$T_c = \left( \frac{11.9 \times L^3}{\Delta H} \right)^{0.385} = \left( \frac{11.9 \times 0.47^3}{70} \right)^{0.385}$$

$$T_c = 0.21 \text{ HR.}$$
  - b) BY VELOCITY ESTIMATE:
 
$$\text{AVERAGE SLOPE} = 2.8\% \Rightarrow V = 3 \text{ FPS}$$

$$T_c = \frac{L}{V} = \frac{2500}{3 \times 3600} = 0.23 \text{ HR.}$$

$$\text{USE } T_c = 0.21 \text{ HR}$$
8. LAG TIME  $= 0.6 \times T_c = 0.6 \times 0.21 = 0.13 \text{ HR}$
9. UNIT DURATION  $= D \leq \frac{L}{3} = \frac{0.13}{3} = 0.0433$   

$$\text{USE } D = 0.033 \text{ HR} = 5 \text{ MIN}$$
10. TIME TO PEAK,  $T_p = \frac{D}{2} + L_t = 0.17 \text{ HR}$
11. PEAK DISCHARGE,  $q_p = \frac{484 \cdot A}{T_p} = \frac{484 \times (1.10)}{0.17}$   

$$q_p = 3132 \text{ CFS}$$

BROOKFIELD CITY DAM (#10181)HYDROLOGIC SOIL GROUP AND CURVE NUMBER

1. WATERSHED SOILS IN THE BASIN CONSIST OF GROUP C, AND D SOILS, WITH GROUP C BEING PREDOMINANT. ASSUME GROUP C SOILS FOR HYDROLOGIC PURPOSES OVER THE ENTIRE WATERSHED.
2. THIS WATERSHED IS PRIMARILY AGRICULTURAL WITH PASTURE AND RANGE LAND COVERING MOST OF THE BASIN. ASSUME THE HYDROLOGIC CONDITION OF THIS WATERSHED IS "FAIR".

THUS  $CN = 79$  (PASTURE AND RANGE)

WITH  $AMC II$

$\Rightarrow$   $CN = 91$  WITH  $AMC III$

HEC1DB INPUT DATA

.....  
 PLUG HYDROGRAPH PACKAGE (HEC-1)  
 DAM SAFETY VERSION JULY 1978  
 LAST MODIFICATION 26 FEB 79  
 .....

0.0M SAFETY INSPECTION - MISSOURI  
 BROOKFIELD CITY DAM (66-101-1)  
 PNF AND 50 PERCENT PNF

1	A1	0	0	0	0	0	0	0	0
2	A2	0	0	0	0	0	0	0	0
3	A3	300	0	5	0	0	0	0	0
4	B	31	0	1	0	0	0	0	0
5	C	1	2	1	0	0	0	0	0
6	D	1	0	1	0	0	0	0	0
7	E	0	12.01	0	0	0	0	0	0
8	F	1	2	1.1	1.1	1.1	1.1	1.1	1.1
9	G	1	100	120	130	130	130	130	130
10	H	1	0.1	0.1	0.1	0.1	0.1	0.1	0.1
11	I	1	1	1	1	1	1	1	1
12	J	1	1	1	1	1	1	1	1
13	K	1	1	1	1	1	1	1	1
14	L	1	1	1	1	1	1	1	1
15	M	1	1	1	1	1	1	1	1
16	N	1	1	1	1	1	1	1	1
17	O	1	1	1	1	1	1	1	1
18	P	1	1	1	1	1	1	1	1
19	Q	1	1	1	1	1	1	1	1
20	R	1	1	1	1	1	1	1	1
21	S	1	1	1	1	1	1	1	1
22	T	1	1	1	1	1	1	1	1
23	U	1	1	1	1	1	1	1	1
24	V	1	1	1	1	1	1	1	1
25	W	1	1	1	1	1	1	1	1

51 ROUTE HYDROGRAPH THROUGH BROOKFIELD CITY DAM

1	V1	0.0	0.0	0.0	0.0	0.0	0.0	0.0	0.0
2	V2	0.0	0.0	0.0	0.0	0.0	0.0	0.0	0.0
3	V3	0.0	0.0	0.0	0.0	0.0	0.0	0.0	0.0
4	V4	0.0	0.0	0.0	0.0	0.0	0.0	0.0	0.0
5	V5	0.0	0.0	0.0	0.0	0.0	0.0	0.0	0.0
6	V6	0.0	0.0	0.0	0.0	0.0	0.0	0.0	0.0
7	V7	0.0	0.0	0.0	0.0	0.0	0.0	0.0	0.0
8	V8	0.0	0.0	0.0	0.0	0.0	0.0	0.0	0.0
9	V9	0.0	0.0	0.0	0.0	0.0	0.0	0.0	0.0
10	V10	0.0	0.0	0.0	0.0	0.0	0.0	0.0	0.0
11	V11	0.0	0.0	0.0	0.0	0.0	0.0	0.0	0.0
12	V12	0.0	0.0	0.0	0.0	0.0	0.0	0.0	0.0
13	V13	0.0	0.0	0.0	0.0	0.0	0.0	0.0	0.0
14	V14	0.0	0.0	0.0	0.0	0.0	0.0	0.0	0.0
15	V15	0.0	0.0	0.0	0.0	0.0	0.0	0.0	0.0
16	V16	0.0	0.0	0.0	0.0	0.0	0.0	0.0	0.0
17	V17	0.0	0.0	0.0	0.0	0.0	0.0	0.0	0.0
18	V18	0.0	0.0	0.0	0.0	0.0	0.0	0.0	0.0
19	V19	0.0	0.0	0.0	0.0	0.0	0.0	0.0	0.0
20	V20	0.0	0.0	0.0	0.0	0.0	0.0	0.0	0.0
21	V21	0.0	0.0	0.0	0.0	0.0	0.0	0.0	0.0
22	V22	0.0	0.0	0.0	0.0	0.0	0.0	0.0	0.0
23	V23	0.0	0.0	0.0	0.0	0.0	0.0	0.0	0.0
24	V24	0.0	0.0	0.0	0.0	0.0	0.0	0.0	0.0
25	V25	0.0	0.0	0.0	0.0	0.0	0.0	0.0	0.0

PREVIEW OF SEQUENCE OF STREAM NETWORK CALCULATIONS

RUNOFF HYDROGRAPH AT 101-1

ROUTE HYDROGRAPH TO

END OF NETWORK

INFLOW PMF AND ONE-HALF PMF HYDROGRAPHS

B-15

.....  
 FLOOD HYDROGRAPH PACKAGE (HEC-1)  
 DAN SAFETY VERSION - JULY 1978  
 LAST MODIFICATION 26 FEB 79.  
 .....

RUN DATE: 7/20/79  
 TIME: 07:08:12

DAN SAFETY INSECTION - MISSOURI  
 PROOFFIELD CITY DAM (NO.101R1)  
 PWF AND 50 PERCENT PMF

UNIT NO: 001    DAM NO: 101R1    JOP SPECIFICATION  
 UNIT NO: 001    DAM NO: 101R1    INR    IMPD    METNC    IPTL    IPRT    MSTAN  
 001    001    0    0    0    0    0    0

MULTI-PHASE ANALYSIS TO BE PERFORMED  
 NPLANE 1 NPTIDE 2 LPTIDE 1

RTI05= 1.00    RTI06= 1.00

..... SURFACE RUNOFF COMPUTATION .....

INPUT PRECIPITATION VALUES, RATIOS AND UNIT HYDROGRAPH PARAMETERS

IST05 10000    TEC05    ITAPE    JPLT    JPAT    INAME    IOSTAGE    IAUTO  
 101R1    0    0    0    0    0    0    0

HYDROGRAPH DATA  
 INVOG 1    TAREA 1.10    SAMP 0.00    TRSEC 1.00    RATIO 0.000    ISNOI 0    ISOME LOCAL  
 2    1.10    0.00    1.10    1.00    0.000    0    0

PRECIP DATA  
 SPEE 0.00    P25 24.25    R5 100.00    S12 120.00    R24 130.00    R40 0.00    R72 0.00    R96 0.00

LOSS DATA  
 LROPT 1    STAK3 0.00    OLTRK 0.00    RTI01 0.00    CRAIN 0.00    STRK3 1.00    STRTL 0.00    CNSTL 0.00    ALSMX 0.00  
 1    0.00    0.00    1.00    0.00    0.00    1.00    -1.00    -0.100    0.00    0.00

CURVE NO = -91.00    WETNESS = -1.00    EFFECT CN = 91.00

UNIT HYDROGRAPH DATA  
 TC= 0.00    LAG= 0.15

STR05= 0.00    RECCSN5= 0.00    RTICR5= 1.00

TYPE INCREMENT TOO LARGE--(INHE IS GT LAG?)

UNIT HYDROGRAPH 10 END OF PERIOD ORDINATES, TC= 0.00 HOURS LAG= 0.15 VOLE 1.00

0-16

000000000000  
 55555555555555  
 000000000000

NO. DA	HP, MIN	PERIOD	RAIN	FACE	LOSS	NO. OF PERIO	FLOW	NO. DA	HP, MIN	PERIOD	RAIN	EXCS	LOSS	COMP O
1.01	2.05	1	.01	1.01	.01	48	1.01	201	17.35	151	.20	.00	16821	
1.01	2.10	2	.01	0.01	.01	48	1.01	201	17.40	152	.20	.00	16891	
1.01	2.15	3	.01	0.00	.01	48	1.01	201	17.45	153	.20	.00	16961	
1.01	2.20	4	.01	0.00	.01	48	1.01	201	17.50	154	.20	.00	17031	
1.01	2.25	5	.01	0.00	.01	48	1.01	201	17.55	155	.20	.00	17101	
1.01	2.30	6	.01	0.00	.01	48	1.01	201	17.58	156	.20	.00	17171	
1.01	2.35	7	.01	0.00	.01	48	1.01	201	18.00	157	.20	.00	17241	
1.01	2.40	8	.01	0.00	.01	48	1.01	201	18.05	158	.20	.00	17311	
1.01	2.45	9	.01	0.00	.01	48	1.01	201	18.10	159	.20	.00	17381	
1.01	2.50	10	.01	0.00	.01	48	1.01	201	18.15	160	.20	.00	17451	
1.01	2.55	11	.01	0.00	.01	48	1.01	201	18.20	161	.20	.00	17521	
1.01	2.60	12	.01	0.00	.01	48	1.01	201	18.25	162	.20	.00	17591	
1.01	2.65	13	.01	0.00	.01	48	1.01	201	18.30	163	.20	.00	17661	
1.01	2.70	14	.01	0.00	.01	48	1.01	201	18.35	164	.20	.00	17731	
1.01	2.75	15	.01	0.00	.01	48	1.01	201	18.40	165	.20	.00	17801	
1.01	2.80	16	.01	0.00	.01	48	1.01	201	18.45	166	.20	.00	17871	
1.01	2.85	17	.01	0.00	.01	48	1.01	201	18.50	167	.20	.00	17941	
1.01	2.90	18	.01	0.00	.01	48	1.01	201	18.55	168	.20	.00	18011	
1.01	2.95	19	.01	0.00	.01	48	1.01	201	19.00	169	.20	.00	18081	
1.01	3.00	20	.01	0.00	.01	48	1.01	201	19.05	170	.20	.00	18151	
1.01	3.05	21	.01	0.00	.01	48	1.01	201	19.10	171	.20	.00	18221	
1.01	3.10	22	.01	0.00	.01	48	1.01	201	19.15	172	.20	.00	18291	
1.01	3.15	23	.01	0.00	.01	48	1.01	201	19.20	173	.20	.00	18361	
1.01	3.20	24	.01	0.00	.01	48	1.01	201	19.25	174	.20	.00	18431	
1.01	3.25	25	.01	0.00	.01	48	1.01	201	19.30	175	.20	.00	18501	
1.01	3.30	26	.01	0.00	.01	48	1.01	201	19.35	176	.20	.00	18571	
1.01	3.35	27	.01	0.00	.01	48	1.01	201	19.40	177	.20	.00	18641	
1.01	3.40	28	.01	0.00	.01	48	1.01	201	19.45	178	.20	.00	18711	
1.01	3.45	29	.01	0.00	.01	48	1.01	201	19.50	179	.20	.00	18781	
1.01	3.50	30	.01	0.00	.01	48	1.01	201	19.55	180	.20	.00	18851	
1.01	3.55	31	.01	0.00	.01	48	1.01	201	20.00	181	.20	.00	18921	
1.01	3.60	32	.01	0.00	.01	48	1.01	201	20.05	182	.20	.00	18991	
1.01	3.65	33	.01	0.00	.01	48	1.01	201	20.10	183	.20	.00	19061	
1.01	3.70	34	.01	0.00	.01	48	1.01	201	20.15	184	.20	.00	19131	
1.01	3.75	35	.01	0.00	.01	48	1.01	201	20.20	185	.20	.00	19201	
1.01	3.80	36	.01	0.00	.01	48	1.01	201	20.25	186	.20	.00	19271	
1.01	3.85	37	.01	0.00	.01	48	1.01	201	20.30	187	.20	.00	19341	
1.01	3.90	38	.01	0.00	.01	48	1.01	201	20.35	188	.20	.00	19411	
1.01	3.95	39	.01	0.00	.01	48	1.01	201	20.40	189	.20	.00	19481	
1.01	4.00	40	.01	0.00	.01	48	1.01	201	20.45	190	.20	.00	19551	
1.01	4.05	41	.01	0.00	.01	48	1.01	201	20.50	191	.20	.00	19621	
1.01	4.10	42	.01	0.00	.01	48	1.01	201	20.55	192	.20	.00	19691	
1.01	4.15	43	.01	0.00	.01	48	1.01	201	21.00	193	.20	.00	19761	
1.01	4.20	44	.01	0.00	.01	48	1.01	201	21.05	194	.20	.00	19831	
1.01	4.25	45	.01	0.00	.01	48	1.01	201	21.10	195	.20	.00	19901	
1.01	4.30	46	.01	0.00	.01	48	1.01	201	21.15	196	.20	.00	19971	
1.01	4.35	47	.01	0.00	.01	48	1.01	201	21.20	197	.20	.00	20041	
1.01	4.40	48	.01	0.00	.01	48	1.01	201	21.25	198	.20	.00	20111	
1.01	4.45	49	.01	0.00	.01	48	1.01	201	21.30	199	.20	.00	20181	
1.01	4.50	50	.01	0.00	.01	48	1.01	201	21.35	200	.20	.00	20251	
1.01	4.55	51	.01	0.00	.01	48	1.01	201	21.40	201	.20	.00	20321	
1.01	4.60	52	.01	0.00	.01	48	1.01	201	21.45	202	.20	.00	20391	
1.01	4.65	53	.01	0.00	.01	48	1.01	201	21.50	203	.20	.00	20461	
1.01	4.70	54	.01	0.00	.01	48	1.01	201	21.55	204	.20	.00	20531	
1.01	4.75	55	.01	0.00	.01	48	1.01	201	22.00	205	.20	.00	20601	

B-17

1.01	4.42	56	.01	.01	661	1.01	17.10	207	.02	.02	2153
1.01	4.45	57	.01	.01	671	1.01	17.15	207	.02	.02	1997
1.01	4.50	58	.01	.01	681	1.01	17.20	209	.02	.02	1939
1.01	4.55	59	.01	.01	691	1.01	17.25	209	.02	.02	1912
1.01	5.00	60	.01	.01	701	1.01	17.30	210	.02	.02	1900
1.01	5.05	61	.01	.01	711	1.01	17.35	211	.02	.02	1894
1.01	5.10	62	.01	.01	721	1.01	17.40	212	.02	.02	1892
1.01	5.15	63	.01	.01	731	1.01	17.45	213	.02	.02	1891
1.01	5.20	64	.01	.01	741	1.01	17.50	214	.02	.02	1891
1.01	5.25	65	.01	.01	751	1.01	17.55	215	.02	.02	1891
1.01	5.30	66	.01	.01	761	1.01	17.60	215	.02	.02	1891
1.01	5.35	67	.01	.01	771	1.01	17.65	215	.02	.02	1891
1.01	5.40	68	.01	.01	781	1.01	17.70	217	.02	.02	1891
1.01	5.45	69	.01	.01	791	1.01	17.75	218	.02	.02	1891
1.01	5.50	70	.01	.01	801	1.01	17.80	218	.02	.02	1891
1.01	5.55	71	.01	.01	811	1.01	17.85	220	.02	.02	1891
1.01	5.60	72	.01	.01	821	1.01	17.90	221	.02	.02	1891
1.01	5.65	73	.01	.01	831	1.01	17.95	222	.02	.02	1891
1.01	5.70	74	.01	.01	841	1.01	18.00	222	.02	.02	1891
1.01	5.75	75	.01	.01	851	1.01	18.05	224	.02	.02	1891
1.01	5.80	76	.01	.01	861	1.01	18.10	224	.02	.02	1891
1.01	5.85	77	.01	.01	871	1.01	18.15	225	.02	.02	1891
1.01	5.90	78	.01	.01	881	1.01	18.20	225	.02	.02	1891
1.01	5.95	79	.01	.01	891	1.01	18.25	227	.02	.02	1891
1.01	6.00	80	.01	.01	901	1.01	18.30	228	.02	.02	1891
1.01	6.05	81	.01	.01	911	1.01	18.35	229	.02	.02	1891
1.01	6.10	82	.01	.01	921	1.01	18.40	230	.02	.02	1891
1.01	6.15	83	.01	.01	931	1.01	18.45	231	.02	.02	1891
1.01	6.20	84	.01	.01	941	1.01	18.50	231	.02	.02	1891
1.01	6.25	85	.01	.01	951	1.01	18.55	232	.02	.02	1891
1.01	6.30	86	.01	.01	961	1.01	18.60	232	.02	.02	1891
1.01	6.35	87	.01	.01	971	1.01	18.65	233	.02	.02	1891
1.01	6.40	88	.01	.01	981	1.01	18.70	233	.02	.02	1891
1.01	6.45	89	.01	.01	991	1.01	18.75	233	.02	.02	1891
1.01	6.50	90	.01	.01	1001	1.01	18.80	234	.02	.02	1891
1.01	6.55	91	.01	.01	1011	1.01	18.85	234	.02	.02	1891
1.01	6.60	92	.01	.01	1021	1.01	18.90	235	.02	.02	1891
1.01	6.65	93	.01	.01	1031	1.01	18.95	235	.02	.02	1891
1.01	6.70	94	.01	.01	1041	1.01	19.00	237	.02	.02	1891
1.01	6.75	95	.01	.01	1051	1.01	19.05	237	.02	.02	1891
1.01	6.80	96	.01	.01	1061	1.01	19.10	237	.02	.02	1891
1.01	6.85	97	.01	.01	1071	1.01	19.15	242	.02	.02	1891
1.01	6.90	98	.01	.01	1081	1.01	19.20	243	.02	.02	1891
1.01	6.95	99	.01	.01	1091	1.01	19.25	243	.02	.02	1891
1.01	7.00	100	.01	.01	1101	1.01	19.30	243	.02	.02	1891
1.01	7.05	101	.01	.01	1111	1.01	19.35	245	.02	.02	1891
1.01	7.10	102	.01	.01	1121	1.01	19.40	245	.02	.02	1891
1.01	7.15	103	.01	.01	1131	1.01	19.45	245	.02	.02	1891
1.01	7.20	104	.01	.01	1141	1.01	19.50	247	.02	.02	1891
1.01	7.25	105	.01	.01	1151	1.01	19.55	247	.02	.02	1891
1.01	7.30	106	.01	.01	1161	1.01	19.60	247	.02	.02	1891
1.01	7.35	107	.01	.01	1171	1.01	19.65	248	.02	.02	1891
1.01	7.40	108	.01	.01	1181	1.01	19.70	248	.02	.02	1891
1.01	7.45	109	.01	.01	1191	1.01	19.75	248	.02	.02	1891
1.01	7.50	110	.01	.01	1201	1.01	19.80	248	.02	.02	1891
1.01	7.55	111	.01	.01	1211	1.01	19.85	248	.02	.02	1891
1.01	7.60	112	.01	.01	1221	1.01	19.90	248	.02	.02	1891
1.01	7.65	113	.01	.01	1231	1.01	19.95	248	.02	.02	1891
1.01	7.70	114	.01	.01	1241	1.01	20.00	248	.02	.02	1891
1.01	7.75	115	.01	.01	1251	1.01	20.05	248	.02	.02	1891
1.01	7.80	116	.01	.01	1261	1.01	20.10	248	.02	.02	1891
1.01	7.85	117	.01	.01	1271	1.01	20.15	248	.02	.02	1891
1.01	7.90	118	.01	.01	1281	1.01	20.20	248	.02	.02	1891
1.01	7.95	119	.01	.01	1291	1.01	20.25	248	.02	.02	1891
1.01	8.00	120	.01	.01	1301	1.01	20.30	248	.02	.02	1891
1.01	8.05	121	.01	.01	1311	1.01	20.35	248	.02	.02	1891
1.01	8.10	122	.01	.01	1321	1.01	20.40	248	.02	.02	1891
1.01	8.15	123	.01	.01	1331	1.01	20.45	248	.02	.02	1891
1.01	8.20	124	.01	.01	1341	1.01	20.50	248	.02	.02	1891
1.01	8.25	125	.01	.01	1351	1.01	20.55	248	.02	.02	1891
1.01	8.30	126	.01	.01	1361	1.01	20.60	248	.02	.02	1891
1.01	8.35	127	.01	.01	1371	1.01	20.65	248	.02	.02	1891
1.01	8.40	128	.01	.01	1381	1.01	20.70	248	.02	.02	1891
1.01	8.45	129	.01	.01	1391	1.01	20.75	248	.02	.02	1891
1.01	8.50	130	.01	.01	1401	1.01	20.80	248	.02	.02	1891
1.01	8.55	131	.01	.01	1411	1.01	20.85	248	.02	.02	1891
1.01	8.60	132	.01	.01	1421	1.01	20.90	248	.02	.02	1891
1.01	8.65	133	.01	.01	1431	1.01	20.95	248	.02	.02	1891
1.01	8.70	134	.01	.01	1441	1.01	21.00	248	.02	.02	1891
1.01	8.75	135	.01	.01	1451	1.01	21.05	248	.02	.02	1891
1.01	8.80	136	.01	.01	1461	1.01	21.10	248	.02	.02	1891
1.01	8.85	137	.01	.01	1471	1.01	21.15	248	.02	.02	1891
1.01	8.90	138	.01	.01	1481	1.01	21.20	248	.02	.02	1891
1.01	8.95	139	.01	.01	1491	1.01	21.25	248	.02	.02	1891
1.01	9.00	140	.01	.01	1501	1.01	21.30	248	.02	.02	1891
1.01	9.05	141	.01	.01	1511	1.01	21.35	248	.02	.02	1891
1.01	9.10	142	.01	.01	1521	1.01	21.40	248	.02	.02	1891
1.01	9.15	143	.01	.01	1531	1.01	21.45	248	.02	.02	1891
1.01	9.20	144	.01	.01	1541	1.01	21.50	248	.02	.02	1891
1.01	9.25	145	.01	.01	1551	1.01	21.55	248	.02	.02	1891
1.01	9.30	146	.01	.01	1561	1.01	21.60	248	.02	.02	1891
1.01	9.35	147	.01	.01	1571	1.01	21.65	248	.02	.02	1891
1.01	9.40	148	.01	.01	1581	1.01	21.70	248	.02	.02	1891
1.01	9.45	149	.01	.01	1591	1.01	21.75	248	.02	.02	1891
1.01	9.50	150	.01	.01	1601	1.01	21.80	248	.02	.02	1891

B-18







SUMMARY OF PMF AND ONE-HALF PMF FLOOD ROUTING

B-22

PEAK FLOW AND STORAGE (END OF PERIOD) SUMMARY FOR MULTIPLE FLOW-RATIO ECONOMIC COMPUTATIONS  
 FLOWS IN CUBIC FEET PER SECOND (CUBIC METERS PER SECOND)  
 AREA IN SQUARE FEET (SQ. METERS)

RATIOS APPLIED TO FLOWS

DESCRIPTION	STATION	AREA	PLAN	RATIO 1	RATIO 2
				1.00	.50
HYDROGRAPH AT	11101	1410	1	1.0000	0.5000
		( 0.85)		( 0.9160)	( 0.4580)
ROUTED TO	1110	1410	1	0.5000	0.2500
	( 0.85)			( 0.1250)	( 0.1250)

SUMMARY OF DAM SAFETY ANALYSIS

SECTION	ELEVATION OF STORAGE	INITIAL VALUE	SPILLWAY CREST	TOP OF DAM	MAXIMUM DEPTH OVER DAM	MAXIMUM STORAGE	MAXIMUM OUTFLOW CFS	DURATION OVER TOP	TIME OF MAX OUTFLOW	TIME OF FAILURE
NO.	FEET	FEET	FEET	FEET	FEET	AC-FT	CFS	HOURS	HOURS	HOURS
1000	075.00	000.00	400.00	405.00	0.00	2501.	458.	0.75	16.00	0.00
050	075.00	140.00	400.00	405.00	0.00	2248.	1723.	0.00	16.00	0.00

PERCENT OF PMF FLOOD ROUTING  
EQUAL TO SPILLWAY CAPACITY

B-25

PROVIDES OF SEQUENCE OF STREAM NETWORK CALCULATIONS

RUN-OFF HYDROGRAPH AT  
ROUTE (HYDROGRAPH T)  
OF NETWORK

B-26

AD-A104 613

CONSOER TOWNSEND AND ASSOCIATES LTD ST LOUIS MO  
NATIONAL DAM SAFETY PROGRAM, BROOKFIELD CITY DAM (NO 10181); GR-ETC(U)  
DEC 79 W G SHIFRIN DACW43-79-C-0075  
NL

UNCLASSIFIED

2 of 2  
404  
102013



END  
DATE  
FILMED  
10-81  
DTIC

.....  
 FLOOD HYDROGRAPH PACKAGE (HEC-1)  
 DAM SAFETY VERSION JULY 1979  
 LAST MODIFICATION 26 FEB 79  
 .....

RUN DATE: 79/09/28  
 TIME: 07:31:00

DAM SAFETY INSPECTION - MISSOURI  
 BROOKFIELD CITY DAM (NO.10111)  
 PERCENT DEF

NO	UNIT	DATE	TIME	PERCENT DEF	REMARKS
1	0	0	0	0	.....
2	0	0	0	0	.....
3	0	0	0	0	.....
4	0	0	0	0	.....
5	0	0	0	0	.....
6	0	0	0	0	.....
7	0	0	0	0	.....
8	0	0	0	0	.....
9	0	0	0	0	.....
10	0	0	0	0	.....
11	0	0	0	0	.....
12	0	0	0	0	.....
13	0	0	0	0	.....
14	0	0	0	0	.....
15	0	0	0	0	.....
16	0	0	0	0	.....
17	0	0	0	0	.....
18	0	0	0	0	.....
19	0	0	0	0	.....
20	0	0	0	0	.....
21	0	0	0	0	.....
22	0	0	0	0	.....
23	0	0	0	0	.....
24	0	0	0	0	.....
25	0	0	0	0	.....
26	0	0	0	0	.....
27	0	0	0	0	.....
28	0	0	0	0	.....
29	0	0	0	0	.....
30	0	0	0	0	.....

MULTI-PLAN ANALYSIS TO BE PERFORMED  
 RELEASE 1 PARTIAL RELEASE 1

.....  
 SUB-BASE RUNOFF COMPUTATION  
 .....

INPUT PRECIPITATION VALUES, RATIOS AND UNIT HYDROGRAPH PARAMETERS

ISTAT	ICOMP	IECON	ITAPE	JPLY	JUPT	ISAKE	ISTAGE	IAUTJ
1	0	0	0	0	0	0	0	0
2	0	0	0	0	0	0	0	0

HYDROGRAPH DATA

IMYD	ITIME	Q	TSODA	TSOFC	RATIO	ISNOV	ISAKE	LOCAL
1	0	0	0	0	0	0	0	0
2	0	0	0	0	0	0	0	0

PRECIP. DATA

SPFE	PVS	R1	R2	R3	R4	R5	R6	R7	R8	R9
0.00	20.25	10.00	120.00	130.00	0.00	0.00	0.00	0.00	0.00	0.00

LOSS DATA

LMOFT	STARR	RTIOL	EMAIN	STPKS	RTIOM	SEPTL	CVSIL	ALSMY	RTI9F
0	0.00	1.00	0.00	0.00	1.00	-1.00	-0.00	0.00	0.00

CURVE NO = 01.00 METNESS = -1.00 EFFECT CN = 11.00

UNIT HYDROGRAPH DATA

TC	LAG	LAG
0.00	0.00	0.13

RECESSION DATA

RTI9E	ARCSE	RTI9E
0.00	0.00	1.00

END-OF-PERIOD FLOW

MO,DA	HR,MIN	PERIOD	RAIN	FACS	LOSS	COND
0	0	0	0	0	0	0



PEAK FLOW AND STORAGE (END OF PL-100) SUMMARY FOR MULTIPLE PLAIN-PLATE LAMINAR COMPUTATIONS  
 FLOWS IN CUBIC FEET PER SECOND (CUBIC METERS PER SECOND)  
 AREA IN SQUARE FEET (SQUARE KILOMETERS)

OPERATION	STATION	AREA	PLAN	RATIOS APPLIED TO FLOWS					
				RATIO 1	RATIO 2	RATIO 3	RATIO 4	RATIO 5	
HYDROGRAPH AT	12101	1.10	1	31220	31231	32101	32240	32579	32518
	( 2485)	( )	( )	( 33277)	( 33272)	( 32253)	( 34659)	( 35253)	( 35249)
ROUTED TO	( )	( 1.17	1	32811	32811	32731	32741	34241	35071
	( )	( 2.85)	( )	( 9124)	( 9312)	( 9479)	( 9567)	( 9794)	( 9924)

SUMMARY OF DAM SAFETY ANALYSIS

RATIO OF P.F.	MAXIMUM DEPTH OVER DAM	MAXIMUM STORAGE AC-FT	MAXIMUM OUTFLOW CFS	DURATION OVER TGP HOURS	TIME OF MAX OUTFLOW HOURS	TIME OF FAILURE HOURS	INITIAL VALUE	
							SPILLWAY CREST	TOP OF DAM
0.65	0.00	2512.	3243.	0.00	16.08	0.00	905.00	805.00
0.66	0.00	2518.	3286.	0.00	16.08	0.00	1892.	2539.
0.67	0.00	2524.	3333.	0.00	16.08	0.00	0.	3446.
0.68	0.00	2530.	3379.	0.00	16.08	0.00		
0.69	0.00	2536.	3424.	0.00	16.08	0.00		
0.70	0.00	2542.	3509.	0.17	16.08	0.00		

B-30