

AD-A104 691

HORNER AND SHIFRIN INC ST LOUIS MO  
NATIONAL DAM SAFETY PROGRAM. SUGAR HOLLOW LAKE DAM (MO 30522), --ETC(U)  
SEP 80

DACW43-80-C-0063

F/G 13/13

NL

UNCLASSIFIED

1 OF 1  
40-A  
10499.

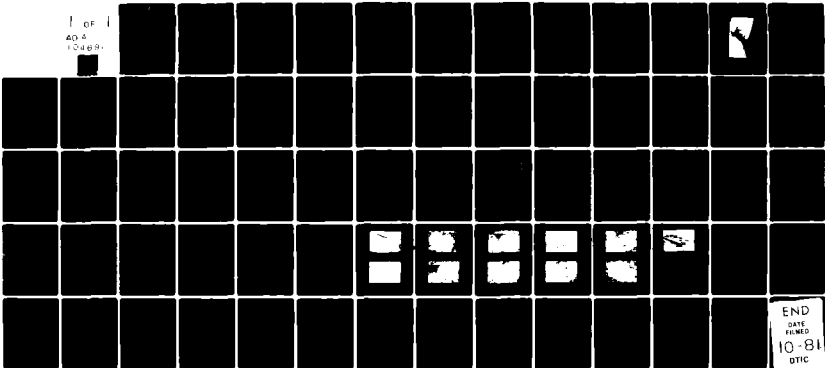

END  
DATE  
FILMED  
10-81  
DTIC

**LEVEL**

Q

3 MISSOURI - KANSAS CITY BASIN

2 SUGAR HOLLOW LAKE DAM,  
4 WARREN COUNTY, MISSOURI  
MO 30522

DTIC  
SELECTED  
SEP 28 1981  
H

AT 104601

# PHASE 1 INSPECTION REPORT NATIONAL DAM SAFETY PROGRAM.



**United States Army  
Corps of Engineers**

*... Serving the Army  
... Serving the Nation*

## St. Louis District

"Original contains color plates: All DTIC reproductions will be in black and white"

DISTRIBUTION STATEMENT A

Approved for public release;  
Distribution Unlimited

PREPARED BY: U.S. ARMY ENGINEER DISTRICT, ST. LOUIS  
FOR THE STATE OF MISSOURI

81 9 28 075

SEPTEMBER 1980

DTIC FILE COPY

F

UNCLASSIFIED

SECURITY CLASSIFICATION OF THIS PAGE (When Data Entered)

REPORT DOCUMENTATION PAGE		READ INSTRUCTIONS BEFORE COMPLETING FORM
1. REPORT NUMBER	2. GOVT ACCESSION NO. <b>AD-A104691</b>	3. RECIPIENT'S CATALOG NUMBER
4. TITLE (and Subtitle) Phase I Dam Inspection Report National Dam Safety Program Sugar Hollow Lake Dam (MO 30522) Warren County, Missouri		5. TYPE OF REPORT & PERIOD COVERED <b>Final Report</b>
7. AUTHOR(s) Horner & Shifrin, Inc.		6. PERFORMING ORG. REPORT NUMBER
9. PERFORMING ORGANIZATION NAME AND ADDRESS U.S. Army Engineer District, St. Louis Dam Inventory and Inspection Section, LMSED-PD 210 Tucker Blvd., North, St. Louis, Mo. 63101		8. CONTRACT OR GRANT NUMBER(s)  DACW43-80-C-0063
11. CONTROLLING OFFICE NAME AND ADDRESS U.S. Army Engineer District, St. Louis Dam Inventory and Inspection Section, LMSED-PD 210 Tucker Blvd., North, St. Louis, Mo. 63101		10. PROGRAM ELEMENT, PROJECT, TASK AREA & WORK UNIT NUMBERS  1-16-1
14. MONITORING AGENCY NAME & ADDRESS (if different from Controlling Office)  National Dam Safety Program. Sugar Hollow Lake Dam (MO 30522), Missouri - Kansas City Basin, Warren County, Missouri. Phase I Inspection Report.		12. REPORT DATE <b>September 1980</b>
16. DISTRIB  Approved for release; distribution unlimited.		13. NUMBER OF PAGES <b>Approximately 40</b>
17. DISTRIBUTION STATEMENT (of the abstract entered in Block 20, if different from Report)		15. SECURITY CLASS. (of this report)  <b>UNCLASSIFIED</b>
18. SUPPLEMENTARY NOTES		15a. DECLASSIFICATION/DOWNGRADING SCHEDULE
19. KEY WORDS (Continue on reverse side if necessary and identify by block number)  Dam Safety, Lake, Dam Inspection, Private Dams		
20. ABSTRACT (Continue on reverse side if necessary and identify by block number)  This report was prepared under the National Program of Inspection of Non-Federal Dams. This report assesses the general condition of the dam with respect to safety, based on available data and on visual inspection, to determine if the dam poses hazards to human life or property.		

417555

7

5012

SECURITY CLASSIFICATION OF THIS PAGE(When Data Entered)



SECURITY CLASSIFICATION OF THIS PAGE(When Data Entered)

**MISSOURI - KANSAS CITY BASIN**

**SUGAR HOLLOW LAKE DAM  
WARREN COUNTY, MISSOURI  
MO 30522**

**PHASE 1 INSPECTION REPORT  
NATIONAL DAM SAFETY PROGRAM**



**United States Army  
Corps of Engineers**

*... Serving the Army  
... Serving the Nation*

**St. Louis District**

**PREPARED BY: U.S. ARMY ENGINEER DISTRICT, ST. LOUIS  
FOR: STATE OF MISSOURI**

**SEPTEMBER 1980**



REPLY TO  
ATTENTION OF

**DEPARTMENT OF THE ARMY**  
ST. LOUIS DISTRICT CORPS OF ENGINEERS  
210 TUCKER BOULEVARD, NORTH  
ST. LOUIS, MISSOURI 63101

LMSD-P

SUBJECT: Sugar Hollow Lake Dam, MO 30522, Phase I Inspection Report

This report presents the results of field inspection and evaluation of the Sugar Hollow Lake Dam, MO 30522:

It was prepared under the National Program of Inspection of Non-Federal Dams.

This dam has been classified as unsafe, non-emergency by the St. Louis District as a result of the application of the following criteria:

- 1) Spillway will not pass 50 percent of the Probable Maximum Flood without overtopping the dam.
- 2) Overtopping of the dam could result in failure of the dam.
- 3) Dam failure significantly increases the hazard to loss of life downstream.

**SIGNED**

**24 SEP 1980**

SUBMITTED BY:

Chief, Engineering Division

Date

**SIGNED**

**25 SEP 1980**

APPROVED BY:

Colonel, CE, District Engineer

Date

Accession For		<input checked="" type="checkbox"/>
NTIS GRA&I		
DTIC TAB		
Unannounced Justification		
By _____		
Distribution/		
Availability codes		
Dist	Availability of	Special
<b>A</b>		

SUGAR HOLLOW LAKE DAM

MISSOURI INVENTORY NO. 30522

WARREN COUNTY, MISSOURI

PHASE I INSPECTION REPORT  
NATIONAL DAM SAFETY PROGRAM

PREPARED BY:

HORNER & SHIFRIN, INC.  
5200 OAKLAND AVENUE  
ST. LOUIS, MISSOURI 63110

FOR:

U.S. ARMY ENGINEER DISTRICT, ST. LOUIS  
CORPS OF ENGINEERS

SEPTEMBER 1980

HS-8011

PHASE I REPORT

NATIONAL DAM SAFETY PROGRAM

Name of Dam:	Sugar Hollow Lake Dam
State Located:	Missouri
County Located:	Warren
Stream:	Tributary of Wolf Creek
Date of Inspection:	20 May 1980

The Sugar Hollow Lake Dam was visually inspected by engineering personnel of Horner & Shifrin, Inc., Consulting Engineers, St. Louis, Missouri. The purpose of this inspection was to assess the general condition of the dam with respect to safety and, based upon this inspection and available data, determine if the dam poses a hazard to human life or property.

Sugar Hollow Lake is one of five lakes located within the development known as Lake Sherwood Estates. The main and largest lake within the development is Lake Sherwood. Lake Sherwood has a surface area of approximately 141 acres. The other four lakes of which Sugar Hollow is the largest with a surface area of about 17 acres, are tributary to Lake Sherwood. A Phase I Inspection Report of the Lake Sherwood Dam, Mo. 10202, was prepared by Kenneth Balk & Associates, Inc., in conjunction with Shannon & Wilson, Inc., for the U.S. Army Engineer District, St. Louis, in January 1979. A plan of the Lake Sherwood Estates Subdivision development, showing the relative location of Sugar Hollow Lake and Lake Sherwood as well as the other three lakes within the development, is presented on Plate 2 of this report.

The following summarizes the findings of the visual inspection and the results of certain hydrologic/hydraulic investigations performed under the direction of the inspection team. Based on the visual inspection and the results of these hydrologic/hydraulic investigations, the present general condition of the Sugar Hollow Lake Dam is considered to be less than satisfactory. The following deficiencies were noticed during the inspection and are considered to have an adverse effect on the overall safety and future operation of the dam:

1. A dense growth of brush and trees up to about 3 inches in diameter covered most of the downstream face of the dam. The upstream face of the dam in the vicinity of the left abutment was similarly affected. Tree roots can provide passageways for lake seepage that could develop into a piping condition (progressive internal erosion) and possible failure of the dam. Brush can conceal animal burrows that could also lead to a piping condition.
2. Minor seepage as evidenced by wet, soft ground, and standing water was observed near the downstream toe at the abutments and close to the center of the dam. Seepage can develop into a piping condition that could result in failure of the dam.
3. At and near the normal waterlines and except for an apparent wave berm along the upstream face of the dam, the upstream and downstream faces of the dam are either unprotected or have only a sparse cover of grass to prevent erosion of the embankment by wave action or by fluctuations of the lake levels. Lake Sherwood abuts the downstream face of the dam and erosion, which according to Mr. Emerson Sanders, the Owner's representative, is due to backwash from the Sugar Hollow Lake spillway pipe discharge, has created a near vertical bank approximately 2 feet high at the downstream toe of the dam in the vicinity of the drop inlet spillway outlet pipe near the center of the dam. A grass covered slope is not considered adequate protection to prevent erosion of the embankment by wave action or by fluctuations in the lake surface level. A wave berm is

considered effective if located at the normal pool level but only if the level of the lake remains fairly constant and wave action is negligible. In any event the slope above the berm should be protected by vegetation.

4. Erosion that appeared to be due to stormwater runoff has created a gulley approximately 4 feet deep at the junction of the downstream face of the dam and the left abutment. Loss of embankment by erosion can be detrimental to the stability of the dam.
5. At a point approximately 6 feet below the top of the drop inlet, the corrugated metal riser section of the inlet was corroded in two locations with some minor leakage entering the inlet through the unsound areas. Since most of the outlet is submerged it was not feasible to examine the entire drop inlet or the outlet pipe at the time of the inspection. It is recommended that the entire spillway, riser section and outlet pipe, be examined for defects since an opening in the riser or outlet pipe could allow infiltration of embankment material resulting in settlement of the dam.
6. Debris, consisting of a sheet of plywood, several large boards, and logs were found along the upstream face of the dam. Numerous boats were also stored in and about a boat rack located on the upstream face of the dam. The possibility exists that debris as well as unsecured boats could, during high water, clog or partially clog the opening of the drop inlet spillway and negate its effectiveness.

According to the criteria set forth in the recommended guidelines, the magnitude of the spillway design flood for the Sugar Hollow Lake Dam, which is classified as intermediate in size and of high hazard potential, is specified to be the Probable Maximum Flood (PMF). The Probable Maximum Flood (PMF) is the flood that may be expected from the most severe combination of critical meteorologic and hydrologic conditions that are

reasonably possible in the region. The PMF is ordinarily accepted as the inflow design flood for dams where failure of the structure would increase the danger to human life.

Results of a hydrologic/hydraulic analysis indicated that the spillways, principal plus auxiliary, are inadequate to pass lake outflow resulting from a storm of PMF magnitude or the outflow resulting from the one percent chance (100-year frequency) flood. The spillways are capable, however, of passing lake outflow resulting from the ten percent chance (10-year frequency) flood and the outflow corresponding to about 8 percent of the PMF. According to the St. Louis District, Corps of Engineers, the length of the downstream damage zone, should failure of the dam occur, is estimated to be six miles. The Lake Sherwood Dam including numerous dwellings adjacent to the affected areas of the lake as well as several dwellings downstream of the Lake Sherwood Dam are within the damage zone.

A review of available data did not disclose that seepage or stability analyses of this dam were performed. This is considered a deficiency and should be rectified.

It is recommended that the Owner take the necessary action without undue delay to correct or control the deficiencies and safety defects reported herein.

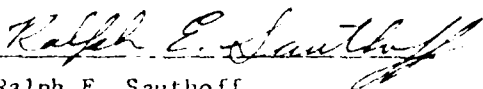

Ralph E. Sauthoff

P. E. Missouri E-19090

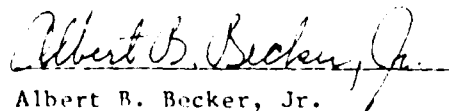

Albert B. Becker, Jr.

P. E. Missouri E-9168



PHASE 1 INSPECTION REPORT  
NATIONAL DAM SAFETY PROGRAM

SUGAR HOLLOW LAKE DAM - MO. 30522

TABLE OF CONTENTS

<u>Paragraph No.</u>	<u>Title</u>	<u>Page No.</u>
SECTION 1 - PROJECT INFORMATION		
1.1	General	1-1
1.2	Description of Project	1-1
1.3	Pertinent Data	1-4
SECTION 2 - ENGINEERING DATA		
2.1	Design	2-1
2.2	Construction	2-1
2.3	Operation	2-1
2.4	Evaluation	2-2
SECTION 3 - VISUAL INSPECTION		
3.1	Findings	3-1
3.2	Evaluation	3-4
SECTION 4 - OPERATIONAL PROCEDURES		
4.1	Procedures	4-1
4.2	Maintenance of Dam	4-1
4.3	Maintenance of Operating Facilities	4-1
4.4	Description of Any Warning System in Effect	4-1
4.5	Evaluation	4-1

<u>Paragraph No.</u>	<u>Title</u>	<u>Page No.</u>
	SECTION 5 - HYDRAULIC/HYDROLOGIC	
5.1	Evaluation of Features	5-1
	SECTION 6 - STRUCTURAL STABILITY	
6.1	Evaluation of Structural Stability	6-1
	SECTION 7 - ASSESSMENT/REMEDIAL MEASURES	
7.1	Dam Assessment	7-1
7.2	Remedial Measures	7-2

LIST OF PLATES

<u>Plate No.</u>	<u>Title</u>
1	Regional Vicinity Map
2	Subdivision Plat
3	Lake Watershed Map
4	Dam Plan & Profile
5	Dam Cross-Section & Spillway Profiles

APPENDIX A - INSPECTION PHOTOGRAPHS

<u>Page No.</u>	<u>Title</u>
A-1 through A-6	Inspection Photographs

APPENDIX B - HYDROLOGIC AND HYDRAULIC ANALYSES

<u>Page No.</u>	<u>Title</u>
B-1 thru B-3	Hydrologic & Hydraulic Computations
B-4 thru B-8	Computer Input Data
B-9 thru B-12	Computer Output Data
B-13	Lake Surface Area, Capacity and Elevations: Summary of Dam Safety Analysis
B-14	Summary of Dam Safety Analysis, Cont.

PHASE I INSEPCION REPORT  
NATIONAL DAM SAFETY PROGRAM

SUGAR HOLLOW LAKE DAM - MO. 30522

SECTION 1 - PROJECT INFORMATION

1.1 GENERAL

a. Authority. The National Dam Inspection Act, Public Law 92-367, dated 8 August 1972, authorized the Secretary of the Army, through the Corps of Engineers, to initiate a program of safety inspection of dams throughout the United States. Pursuant to the above, the St. Louis District, Corps of Engineers, directed that a safety inspection of the Sugar Hollow Lake Dam be made.

b. Purpose of Inspection. The purpose of this visual inspection was to make an assessment of the general condition of the dam with respect to safety and, based upon available data and this inspection, determine if the dam poses a hazard to human life or property.

c. Evaluation Criteria. This evaluation was performed in accordance with the "Phase I" investigation procedures as prescribed in "Recommended Guidelines for Safety Inspection of Dams," Appendix D to "Report to the Chief of Engineers on the National Program of Inspection of Non-Federal Dams," dated May 1975.

1.2 DESCRIPTION OF PROJECT

a. Description of Dam and Appurtenances. The Sugar Hollow Lake Dam is an earthfill type embankment rising approximately 43 feet above the original streambed. The embankment has an upstream slope (above the waterline) of approximately 1v on 2.2h, a crest width of about 26 feet, and a downstream slope on the order of 1v on 2.0h. A 20-foot wide roadway surfaced with

asphalt traverses the dam crest. The length of the dam is approximately 420 feet. Lake Sherwood abuts the downstream face of the dam near the toe of slope. At normal pool level Sugar Hollow Lake occupies approximately 17 acres and Lake Sherwood about 141 acres. A plan and profile of the Sugar Hollow Lake Dam are shown on Plate 4 and a cross-section of the dam is shown on Plate 5.

The dam has both a principal and an auxiliary spillway. The principal spillway which is located near the center of the dam consists of a 42-inch diameter drop inlet with a 42-inch diameter (according to Mr. Emerson Sanders, a representative of the Owner) outlet pipe that passes beneath the dam discharging into Lake Sherwood. The outlet end of the pipe is submerged by the downstream lake. A circular, rod type trash rack prevents debris from entering the inlet and a vertical, steel plate placed across the inlet opening is provided to prevent vortexing of incoming flow.

The auxiliary spillway, another 42-inch diameter pipe, is located at the right abutment. The spillway pipe also passes through the dam but at an elevation only slightly lower, approximately 1.3 feet, than the low point of the dam crest. The outlet channel for the auxiliary spillway, a dish-shaped section approximately 15 feet wide, follows the right abutment joining Lake Sherwood at a point about 250 feet downstream of the dam. A profile of the principal, drop inlet type, spillway as well as a profile of the auxiliary spillway is shown on Plate 5.

b. Location. The dam is located on an unnamed tributary of Wolf Creek, within the Lake Sherwood Estates Subdivision development. The entrance to Lake Sherwood Estates is located just west of State Route D approximately 5 miles south of the town of New Melle in Warren County, Missouri, as shown on the Regional Vicinty Map, Plate 1. The dam is located in the northwest quadrant of Section 12, Township 45 North Range 1 West.

c. Size Classification. The size classification based on the height of the dam and storage capacity, is categorized as intermediate. (Per Table 1, Recommended Guidelines for Safety Inspection of Dams.)

d. Hazard Classification. Sugar Hollow Lake Dam, according to the St. Louis District, Corps of Engineers, has a high hazard potential, meaning that if the dam should fail, there may be loss of life, serious damage to homes, or extensive damage to agricultural, industrial and commercial facilities, important public utilities, main highways, or railroads. The estimated flood damage zone, should failure of the dam occur, as determined by the St. Louis District, extends six miles downstream of the dam. The Lake Sherwood Dam, including numerous dwellings adjacent to the affected areas of the lake, as well as several dwellings downstream of the Lake Sherwood Dam are within the damage zone. Those features lying within the downstream damage zone reported by the Corps of Engineers, St. Louis District, were verified by the inspection team.

e. Ownership. The lake and dam are owned by the Lake Sherwood Estates Association, Post Office Box 85, Lake Sherwood, Missouri 63357. Mr. Emerson Sanders is the Executive Director of the Association.

f. Purpose of Dam. The dam impounds water for recreational use.

g. Design and Construction History. According to Mr. Emerson Sanders, Executive Director, Lake Sherwood Estates Association, the dam was constructed during the period from 1966 to 1968 and the builder of the dam was the Mertens Construction Company of Fulton, Missouri. Efforts to contact the builder were unsuccessful. Mr. Sanders reported that no records of the original dam design or construction exist in the Owner's possession.

An investigation to determine the spillway capacities of the various lake dams within the Lake Sherwood Estates development including the Sugar Hollow Lake Dam, was made by Horner & Shifrin, Inc., Consulting Engineers, and a report dated March 13, 1978, was prepared. A plan and profile drawing of the dam by County Engineering & Surveying, formerly Lewis and Associates, Warrenton, Missouri, that, according to Mr. Larry Bade of County Engineering, was prepared for spillway studies by engineering consultants, was made available. The information shown on this drawing which is dated March 3, 1978, was used by Horner & Shifrin during the aforementioned spillway investigations.

A Phase I Inspection Report of the Lake Sherwood Dam was prepared in January of 1979 by Kenneth Balk & Associates, Inc., in conjunction with Shannon & Wilson, Inc., for the St. Louis District Corps of Engineers. Although the principal subject of this report is the Lake Sherwood Dam, the investigations include a hydrologic/hydraulic analysis of the Sugar Hollow Lake Dam spillway.

h. Normal Operational Procedure. The lake level is unregulated. Lake outflow is governed by the capacity of a drop inlet type spillway.

### 1.3 PERTINENT DATA

a. Drainage Area. With the exception of some meadowland in the upper regions of the drainage area, the lake watershed is primarily in a native state covered with timber. The watershed above the dam amounts to approximately 974 acres. The watershed area is outlined on Plate 3.

b. Discharge at Damsite.

- (1) Estimated known maximum flood at damsite...95 cfs\* (W.S. Elev. 654.6)
- (2) Spillway capacity (principal + auxiliary)...148 cfs (W.S. Elev. 657.6)

c. Elevation (Ft. above MSL). The following elevations were determined by survey and are based on the elevation of the top of the drop inlet spillway, elevation 650.30, as shown on a drawing of the dam as prepared for the Owner by County Engineering & Surveying (formerly Lewis & Associates) of Warrenton, Missouri.

- (1) Observed pool ... 650.1
- (2) Normal pool ... 650.3
- (3) Spillway crest
  - a. Principal ... 650.3
  - b. Auxiliary ... 656.3
- (4) Maximum experienced pool ... 654.6\*
- (5) Top of dam ... 657.6 (min.)

\* Based on an estimate of lake level as observed by Mr. E. Sanders.

- (6) Streambed at centerline of dam ... 616<sub>+</sub> (est.)
- (7) Maximum tailwater ... 627.6<sub>+</sub>\*
- (8) Observed tailwater ... 620.3 (Lake Sherwood)

d. Reservoir.

- (1) Length at normal pool (Elev. 650.3) ... 2,500 ft.
- (2) Length at maximum pool (Elev. 657.6) ... 2,700 ft.

e. Storage.

- (1) Normal pool ... 178 ac. ft.
- (2) Top of dam (incremental) ... 135 ac. ft.

f. Reservoir Surface.

- (1) Normal pool ... 16 acres
- (2) Top of dam (incremental) ... 4 acre

g. Dam. The height of the dam is defined to be the overall vertical distance from the lowest point of foundation surface at the downstream toe of the barrier to the top of the dam.

- (1) Type ... Earth fill
- (2) Length ... 420 ft.
- (3) Height ... 43 ft. (est.)
- (4) Top width ... 26 ft.
- (5) Side slopes
  - a. Upstream ... 1v on 2.2h (above waterline)
  - b. Downstream ... 1v on 2.0h
- (6) Cutoff ... Unknown
- (7) Slope protection
  - a. Upstream ... Grass, wave berm
  - b. Downstream ... Grass

\* Per Phase I Inspection Report, Lake Sherwood Dam, January 1979.

h. Principal Spillway.

- (1) Type ... Uncontrolled, drop inlet with anti-vortex plate and trash rack.
- (2) Location ... Near center of dam
- (3) Crest elevation ... 650.3
- (4) Approach channel ... Lake
- (5) Outlet pipe ... 42-Inch corrugated metal pipe\*
- (6) Outlet channel ... Lake Sherwood

i. Auxiliary Spillway.

- (1) Type ... Uncontrolled, 42-inch corrugated metal pipe
- (2) Location ... Right abutment
- (3) Invert elevation
  - (a) Upstream ... 656.3
  - (b) Downstream ... 655.0
- (4) Outlet channel ... Dish-shaped section, 15 feet wide

j. Lake Drawdown Facility ... None

\* Per Mr. E. Sanders, Executive Director, Lake Sherwood Estates Association.

## SECTION 2 - ENGINEERING DATA

### 2.1 DESIGN

No data regarding the design of the dam were available. According to Mr. Emerson Sanders, Executive Director, Lake Sherwood Estates Association, the dam was designed and constructed by the Mertens Construction Company of Fulton, Missouri. Efforts to contact the Mertens Company were unsuccessful.

An investigation to determine the spillway capacity of the dam as well as the other four dams within the Lake Sherwood Estates Subdivision, was made for the Owner by Horner & Shifrin, Inc., in 1978. In the Horner & Shifrin report, dated March 13, 1978, the consultants concluded that the spillway for the Sugar Hollow Lake Dam, with an allowance of 1 foot of freeboard, had a capacity of about 115 cfs, which, as stated in the report, corresponded to the lake outflow produced by a storm with a 1-year occurrence frequency.

In the Phase I Inspection Report for the Lake Sherwood Dam, No. 10002, prepared by Kenneth Balk & Associates, et al. in January, 1979, the consultants concluded that the spillway for the Sugar Hollow Lake Dam had a capacity without freeboard of approximately 155 cfs, which according to the report corresponded to less than 5 percent of the probable maximum flood.

### 2.2 CONSTRUCTION

No data regarding construction of the dam were available. According to Mr. Sanders the dam was constructed during the period 1966 to 1968 and was the first dam constructed in the development.

### 2.3 OPERATION

The lake level is uncontrolled and governed by the crest elevation of the principal spillway, a drop inlet type structure, located near the center of the dam. The auxiliary spillway, a 42-inch diameter pipe, with a crest elevation approximately 6.0 feet higher than the crest of the principal spillway and about 1.3 feet lower than the top of the dam at its lowest point,

is located at the right abutment. No indication was found that the dam has been overtopped. Mr. Sanders, reported that the dam has never been overtopped and that the highest lake surface observed occurred during March of 1977 when the lake level was within about 3 feet of the dam crest, approximately 4.3 feet above the crest of the drop inlet spillway. Mr. Sanders reported that this high water elevation was in part a result of blockage of the spillway opening by an unmoored canoe. In April of 1979 Mr. Sanders stated that the lake reached a level that was estimated to be approximately 5 feet below the crest of the dam.

#### 2.4 EVALUATION

a. Availability. With the exception of the spillway study by Horner & Shifrin in 1978 and by Kenneth Balk & Associates in 1979, no engineering data for assessing the design of the dam were available.

b. Adequacy. No structural design data available. Seepage and stability analyses comparable to the requirements of the "Recommended Guidelines for Safety" were not available, which is considered a deficiency. These seepage and stability analyses should be performed for appropriate loading conditions (including earthquake loads) and made a matter of record.

Both the Horner & Shifrin spillway study and the investigation of spillway capacity by Kenneth Balk & Associates indicated the spillway for the Sugar Hollow Lake Dam to be seriously inadequate.

## SECTION 3 -- VISUAL INSPECTION

### 3.1 FINDINGS

a. General. A visual inspection of the Sugar Hollow Lake Dam was made by Horner & Shifrin engineering personnel, R. E. Sauthoff, Civil Engineer, and A. B. Becker, Jr., Civil and Soils Engineer, on 20 May 1980. An examination of the dam area was also made by an engineering geologist, Jerry D. Higgins, Ph. D., a consultant retained by Horner & Shifrin for the purpose of assessing the site geology. Also examined at the time of the inspection, were the areas and features below the dam within the potential flood damage zone. Photographs of the dam taken at the time of the inspection are included on Pages A-1 through A-6 of Appendix A. The locations of the photographs taken during the inspection are indicated on Plate 4.

b. Site Geology. The dam area is located near the northern edge of the Ozark Plateaus Physiographic Province, close to the border with the Dissected Till Plains Section of the Central Lowlands Physiographic Province. The topography is moderately rugged with steep valley walls, and there is approximately 160 feet of relief between the reservoir and the surrounding drainage divides. The bedrock formations consist of gently northward-dipping Ordovician-age sedimentary strata of the Plattin and Kimmswick formations. The Mississippian-age Chouteau formation is reported to cap the surrounding ridgetops. The rock strata is predominantly limestone. Scattered Pennsylvanian-age sink deposits of sandstone and shale rubble were observed in the Kimmswick limestone near ridgetops. The dam and reservoir are located entirely on the Plattin limestone with the Kimmswick limestone exposed in the valley walls above the dam.

The Plattin formation is composed of evenly-bedded, gray, finely-crystalline to micritic limestone. Although the Plattin formation exhibits solution weathering features in some areas of eastern Missouri, no karst features were evident in the area of the dam embankment, and bedrock in the abutments did not appear to be highly solution-weathered. Plattin limestone is exposed in both abutments and along the shoreline. The Kimmswick formation

is a light gray, coarsely crystalline, medium-bedded to massive limestone. Weathered exposures characteristically appear pitted. The Kimmswick is highly solution-weathered, forming an irregular bedrock surface. Pennsylvanian-age sediments of mainly sandstone and shale rubble fill many of the solution features in the Kimmswick. The Kimmswick outcrops in the road cut above the left abutment of the dam, as well as near the ridgetops around the reservoir. The formation occurs well above the dam and reservoir and does not affect their performance.

The unconsolidated surficial materials are composed primarily of thin, stony, residual soils of the Gasconade series. This series consists of shallow, somewhat excessively drained soils derived from weathering of limestone and thinly interbedded shale. They consist of dark grayish-brown, stony, (limestone fragments), silty clays near the surface and rapidly grade into dark brown silty clay with depth. The area exhibits an intricate pattern of shallow soils and exposed bedrock. According to the Unified Soil Classification System the soils range in classification from CL to GC, are moderately permeable, but generally suited for embankments and water impoundments, if soil thickness is adequate. Seepage through the thin soils into bedrock is common.

There appear to be no other significant geology-related problems at the Sugar Hollow site. No adverse geologic conditions were observed that would be considered conducive to severe leakage or embankment instability.

c. Dam. The visible portions of the upstream and downstream faces of the dam (see Photos 1 and 2) as well as the dam crest were inspected and appeared, except where damaged by erosion, to be structurally sound. No undue settlement, cracking of the surface or horizontal misalignment of the dam crest was noticed. The upstream face of the dam, although unprotected, showed little evidence of erosion at the waterline. However, near the downstream toe of the dam at a location in line with and in the vicinity of the spillway outlet pipe, erosion of the embankment had created a near vertical bank (see Photo 7) approximately 2 feet high. The junction of the downstream face of the dam and the left abutment was cluttered with large fallen trees and overgrown with small trees, vines and brush (see Photo 9) such that a thorough

examination of the area was not possible. However, erosion, apparently by overland drainage (see Photo 10), had removed embankment material up to a depth of about 4 feet at the intersection of the dam and the abutment at a location near the mid-height of the dam. Trees up to 3 inches in diameter and several areas of dense brush (see Photo 1) were found on the downstream face of the dam. A similar condition was noted on the upstream face of the dam (see Photo 1) in the vicinity of the left abutment. Debris, consisting of a sheet of plywood, boards, and logs (see Photo 11), that could clog the spillway opening were also found along the upstream face of the dam. A boat rack with many small boats in storage was also observed at the upstream face of the dam. It could not be determined if all the boats that were stored in the rack as well as in the immediate vicinity of the rack were adequately secured in order to prevent clogging of the spillway during high water.

Seepage of a minimal amount was noticed near the downstream toe of slope at both abutments as well as near the center (see Photo 8) of the dam. Due to the fact that Lake Sherwood abuts the toe of the dam, it could not be determined if seepage beneath the dam was occurring.

An examination of a soil sample obtained from the downstream face of the dam indicated the material to be a reddish-brown lean clay (CL) of low-to-medium plasticity.

The visible portions of the drop inlet principal spillway (see Photo 3) was inspected and except for a light coating of rust on the rod type trash screen and anti-vortex plate, was found to be in reasonably good condition. However, at a depth approximately 6 feet below the top of the inlet two small openings that appeared to be a result of corrosion of the corrugated metal riser section were observed. Minor leakage into the inlet as well as the earth fill about the exterior of the riser section could be seen at the openings. The downstream end of the spillway outlet pipe was submerged approximately 2 feet by Lake Sherwood and could not be inspected.

The upstream and downstream ends of the 42-inch diameter auxiliary spillway (see Photos 4 and 5) were examined and both appeared to be in good condition, although a small mound of earth on the order of 10 inches high partially blocked the pipe opening at the upstream end. The outlet channel for the auxiliary spillway (see Photo 6), with the exception of several small trees that were noticed near the downstream end of the channel, was also found to be in good condition.

1. Downstream Channel. Lake Sherwood abuts the toe of the dam. The dam for Lake Sherwood is located approximately 1 mile downstream of the Sugar Hollow Lake Dam. The channel, Wolf Creek, downstream of the Lake Sherwood Dam is unimproved. Wolf Creek joins Tuque Creek, which is also unimproved, approximately 2 miles downstream of the Lake Sherwood Dam. Tuque Creek meets the Missouri River flood plain about 3 miles downstream of the Wolf Creek juncture.

2. Reservoir. The area about the lake is densely covered with trees and for the most part in a natural state. No erosion of the lake banks was evident. The amount of sediment within the lake could not be determined at the time of the inspection; however, judging by the natural and undisturbed condition of the area in the vicinity of the lake, the quantity is believed to be negligible.

### 3.2 EVALUATION

The deficiencies observed during this inspection and noted herein, are not considered of significant importance to warrant immediate remedial action.

Comparison of top of dam elevations obtained at the time of the inspection with dam profile data shown on the drawing prepared by Lewis and Associates in 1978, indicated no discernable settlement had occurred in the interim.

## SECTION 4 - OPERATIONAL PROCEDURES

### 4.1 PROCEDURES

The spillways are uncontrolled. The lake surface level is governed by precipitation runoff, evaporation, seepage, and the capacity of the uncontrolled principal and emergency spillways.

### 4.2 MAINTENANCE OF DAM

According to Mr. Emerson Sanders, Executive Director, Lake Sherwood Estates Association, routine maintenance, such as grass mowing and clearing of the drop inlet spillway intake is done periodically. However, judging by the growth of trees and brush on the upstream and downstream faces as well as the eroded areas at the downstream toe and left abutment of the dam, the inspection team is of the opinion that maintenance of the dam proper has been somewhat neglected.

### 4.3 MAINTENANCE OF OPERATING FACILITIES

No outlet facilities requiring operation exist at this dam, and there is no reservoir regulation plan.

### 4.4 DESCRIPTION OF ANY WARNING SYSTEM IN EFFECT

The inspection did not reveal the existence of a dam failure warning system.

### 4.5 EVALUATION

Lack of adequate maintenance is considered detrimental to the safety of the dam. It is recommended that maintenance of the dam proper be undertaken on a regular basis and that records be kept of all major items of maintenance work performed. It is also recommended that a detailed inspection of the dam be instituted on a regular basis by an engineer experienced in the design and construction of dams and that records be kept of all inspections made and remedial measures taken.

## SECTION 5 - HYDRAULIC/HYDROLOGIC

### 5.1 EVALUATION OF FEATURES

a. Design Data. Design data were not available.

b. Experience Data. The drainage area and lake surface area were developed from the 1972 USGS New Melle, Missouri, Quadrangle Map. The proportions and dimensions of the spillways and dam were developed from surveys made during the inspection. Records of rainfall, streamflow, or flood data for the watershed were not available.

According to the St. Louis District, Corps of Engineers, the estimated flood damage zone, should failure of the dam occur, extends six miles downstream of the dam. Lake Sherwood with a surface area of approximately 141 acres lies immediately downstream of the dam.

c. Visual Observations.

(1) The principal spillway, located near the center of the dam, consists of a 42-inch diameter corrugated metal pipe drop inlet, with a 42-inch diameter corrugated metal pipe outlet under the dam discharging into Lake Sherwood. The outlet end of the pipe is submerged by the lower lake. A rod type trash guard and a steel anti-vortex plate are installed at the entrance to the drop inlet.

(2) The auxiliary spillway, also a 42-inch diameter corrugated metal pipe, is located at the right abutment, and extends through the dam with the invert elevation about 1.3 feet lower than the low point of the dam crest. The auxiliary spillway outlet channel, a dish-shaped section approximately 15 feet wide, follows the right abutment and joins Lake Sherwood about 250 feet a downstream of the dam.

(3) No lake drawdown facilities are provided.

d. Overtopping Potential. The spillways (principal and auxiliary) are inadequate to pass the probable maximum flood, 1/2 the probable maximum flood, or the 1 percent chance (100-year frequency) flood without overtopping the dam. The results of the dam overtopping analyses are as follows:

(Note: The data appearing in the following table has been extracted from the computer output data appearing in Appendix B. Decimal values have been rounded to the nearest one-tenth in order to prevent assumption of unwarranted accuracy.)

<u>Ratio of PMF</u>	<u>Q-Peak Outflow (cfs)</u>	<u>Max Lake W.S. Elev.</u>	<u>Max. Depth (Ft.) of Flow over Dam (Elev. 657.6)</u>	<u>Duration of Overtopping of of Dam (Hrs.)</u>
0.50	6,070	662.9	5.3	11.3
1.00	12,617	665.3	7.7	13.9
1% Chance Flood	297	658.5	0.9	5.0

Elevation 657.6 was found to be the lowest point in the dam crest. The flow safely passing the spillway (principal + auxiliary) just prior to overtopping amounts to approximately 148 cfs, which is the routed outflow corresponding to about 8 percent of the probable maximum flood inflow. During peak flow of the probable maximum flood, the greatest depth of flow over the dam is projected to be 7.7 feet and overtopping will extend across the entire length of the dam.

e. Evaluation of Overtopping Effect. Experience with embankments constructed of similar material (a redish brown lean clay of low-to-medium plasticity) to that used to construct this dam have shown evidence that the material under certain conditions, such as high velocity flow, can be very erodible. An example of such erosion is apparent at the junction of the downstream face of the dam and left abutment. Such a condition exists during the PMF when large lake outflow, accompanied by high flow velocities, occurs. For the PMF condition where the depth of flow over the dam crest and the duration of flow over the dam, 7.7 feet (maximum) and 13.9 hours, respectively, are substantial, damage by erosion to the downstream face of the dam is expected. The extent of this damage is not predictable; however, there is a possibility that it could result in failure by erosion of the dam.

f. References. Procedures and data for determining the probable maximum flood, the 100-year frequency flood and the 10-year frequency flood, and the discharge rating curves for flow passing the spillways and dam crest are presented on Pages B-1 through B-3 of Appendix B. Listings of the HEC-1 (Dam Safety Version) input data for the probable maximum flood, the 100-year frequency flood, and the 10-year frequency flood are shown on pages B-4 through B-8. Computer output data, including unit hydrograph ordinates, tabulation of PMF rainfall, loss and inflow data are shown on pages B-9 through B-12; tabulation of lake surface area, elevation and storage volume is shown on page B-13; and tabulation titled "Summary of Dam Safety Analysis" for the PMF is also shown on page B-13. Tabulations titled "Summary of Dam Safety Analysis" for the 1 percent chance (100-year frequency) flood and for the 10 percent chance (10-year frequency) flood are shown on page B-14.

## SECTION 6 - STRUCTURAL STABILITY

### 6.1 EVALUATION OF STRUCTURAL STABILITY

a. Visual Observations. Visual observations of conditions which adversely affect the structural stability of the dam are discussed in Section 3, paragraph 3.1c.

b. Design and Construction Data. No design or construction data relating to the structural stability of the dam are known to exist. Seepage and stability analyses comparable to the requirements of the "Recommended Guidelines for Safety Inspection of Dams" were not available, which is considered a deficiency. These seepage and stability analyses should be performed for appropriate loading conditions (including earthquake loads) and made a matter of record.

c. Operating Records. No appurtenant structures or facilities requiring operation exist at this dam. According to Mr. Emerson Sanders, Executive Director for the Lake Sherwood Estates Association, no records are kept of the lake level, spillway discharge, dam settlement, or seepage.

d. Post Construction Changes. Mr. Sanders also reported that to his knowledge no post construction changes have been made or have occurred which would affect the structural stability of the dam.

e. Seismic Stability. The dam is located in an area close to the boundary separating the Zone I and Zone II seismic probability areas. An earthquake of the magnitude that might occur in this area would not be expected to cause structural damage to a well constructed earth dam of this size provided that static stability conditions are satisfactory and conventional safety margins exist. However, it is recommended that the prescribed seismic loading be applied in any stability analyses performed for this dam.

## SECTION 7 - ASSESSMENT/REMEDIAL MEASURES

### 7.1 DAM ASSESSMENT

a. Safety. A hydraulic analysis indicated that the spillways (principal plus auxiliary) are capable of passing lake outflow of about 148 cfs without the level of the lake exceeding the low point in the top of the dam. A hydrologic analysis of the lake watershed area, as discussed in Section 5, paragraph 5.1d, indicates that for storm runoff of probable maximum flood magnitude, the lake outflow would be about 12,617 cfs, and that for the 1 percent chance (100-year frequency) flood, the lake outflow would be about 297 cfs. A similar analysis indicated that for the 10 percent (10-year frequency) flood, the lake outflow would be approximately 98 cfs.

Seepage and stability analyses of the dam were not available for review and therefore no judgment could be made with respect to the structural stability of the dam.

Several items were noticed during the inspection that could adversely affect the safety of the dam. These items include trees and brush on the dam slopes, erosion of the embankment, seepage, and the lack of adequate erosion protection along the upstream and downstream faces of the dam.

b. Adequacy of Information. Due to lack of design and construction data, the assessments reported herein were based on external conditions as determined during the visual inspection. The assessment of the hydrology of the watershed and capacities of the spillways were based on a hydrologic/hydraulic study as indicated in Section 5. Seepage and stability analyses comparable to the requirements of "Recommended Guidelines for Safety Inspection of Dams" were not available, which is considered a deficiency.

c. Urgency. The remedial measures recommended in paragraph 7.2 for the items concerning the safety of the dam as noted in paragraph 7.1a, should be accomplished without undue delay. It is recommended, that priority be given to increasing the capacity of the spillway outlets which are considered to be seriously inadequate.

d. Necessity for Phase II. Based on the results of the Phase I inspection, a Phase II investigation is not recommended.

e. Seismic Stability. The dam is located in an area close to the boundary separating the Zone I and Zone II seismic probability areas. An earthquake of the magnitude that might occur in this area would not be expected to cause structural damage to a well constructed earth dam of this size provided that static stability conditions are satisfactory and conventional safety margins exist. However, it is recommended that the prescribed seismic loading be applied in any stability analyses performed for this dam.

## 7.2 REMEDIAL MEASURES

a. Recommendations. The following actions are recommended:

(1) Based upon criteria set forth in the recommended guidelines, spillway size and/or height of dam should be increased to pass lake outflow resulting from a storm of probable maximum flood magnitude.

(2) Obtain the necessary soil data and perform dam seepage and stability analyses in order to determine the structural stability of the dam for all operational conditions. Seepage and stability analyses should be performed by a qualified professional engineer experienced in the design and construction of earthen dams.

b. Operations and Maintenance (O & M) Procedures. The following O & M Procedures are recommended:

(1) Remove the trees and undergrowth that may conceal animal burrows from the upstream and downstream faces of the dam. Tree roots and animal burrows can provide passageways for lake seepage that could lead to a piping condition and failure of the dam.

(2) Provide some means of controlling seepage evident in the areas just above the downstream toe of the dam. Uncontrolled seepage can lead to a piping condition which could result in failure of the dam.

(3) Provide some form of protection other than grass for the upstream face of the dam at and above the normal waterline in order to prevent erosion. A similar type of protection should be provided at the downstream toe of the dam through the limits of level of Lake Sherwood.

(4) Provide some form of protection to prevent erosion of the embankment by overland drainage at the junction of the downstream face of the dam and the left abutment. Loss of embankment by erosion can result in instability of the dam.

(5) Assess the condition of the drop inlet spillway including the outlet pipe that passes beneath the dam in order to determine if additional openings and/or unsound areas (the corrugated metal pipe riser section was noticeably corroded at a location about 6 feet below the top of the inlet) exist. An opening in the inlet or outlet pipe could allow infiltration of embankment material resulting in settlement of the dam.

(6) Remove the large items of debris (plywood, boards, logs) from the upstream face of the dam. Floating objects including boats can clog or partially clog the drop inlet spillway opening and negate its effectiveness. It is recommended that the Owner take whatever measures necessary to insure that all boats are secured to their moorings to eliminate the possibility of floating free while unattended during high water.

(7) Provide maintenance of all areas of the dam and spillways on a regularly scheduled basis in order to insure features of being in satisfactory operational condition.

(8) A detailed inspection of the dam should be instituted on a regular basis by an engineer experienced in the design and construction of dams. It is also recommended, for future reference, that records be kept of all inspections made and remedial measures taken.

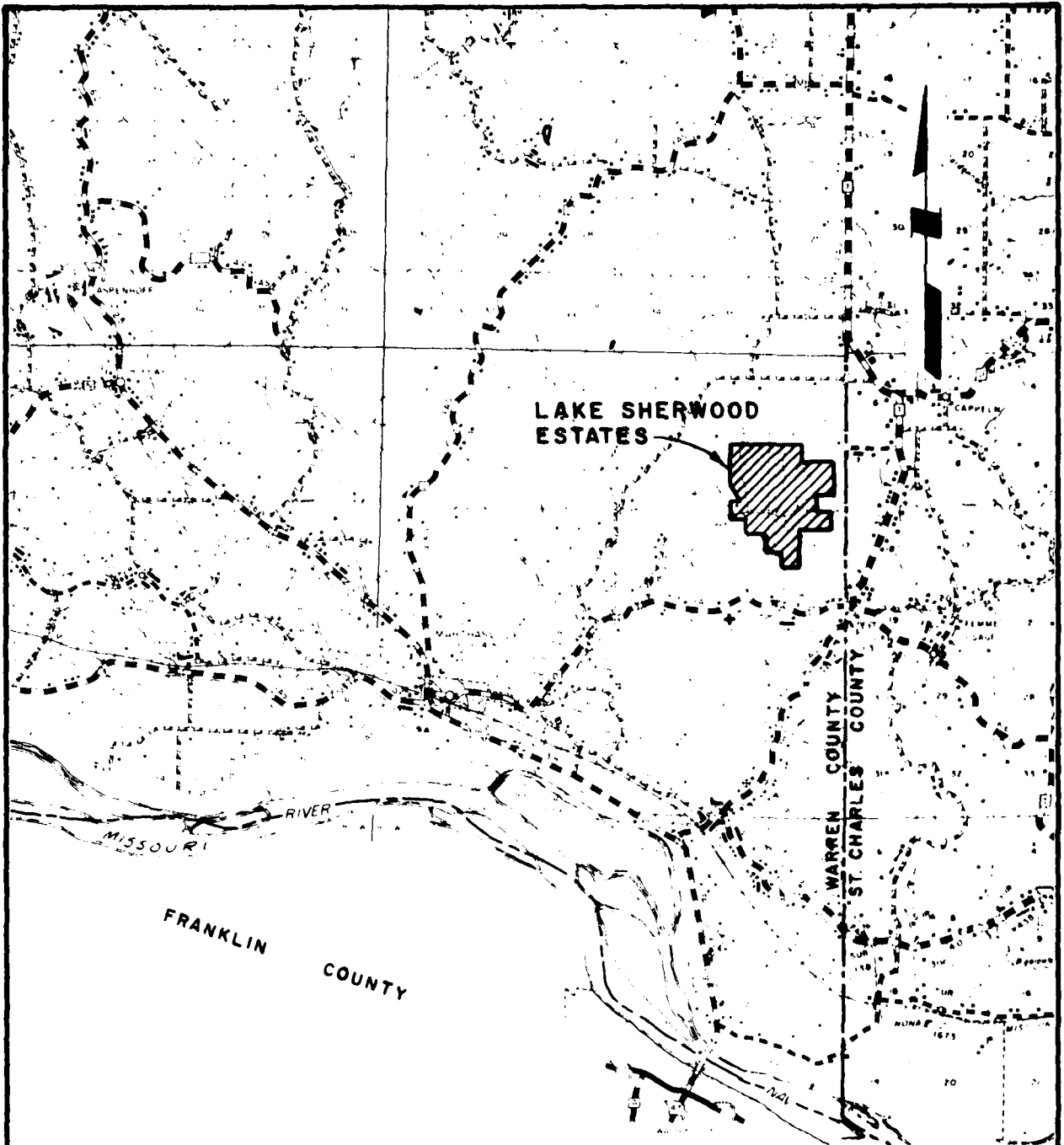

**LAKE SHERWOOD  
ESTATES**

**FRANKLIN  
COUNTY**

**WARREN COUNTY  
ST. CHARLES COUNTY**

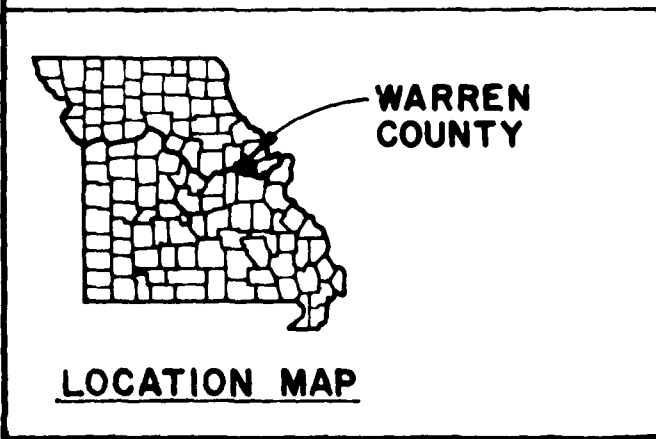

**LOCATION MAP**

**LAKE SHERWOOD ESTATES**



**SCALE (MILES)**

**REGIONAL VICINITY MAP**

LA

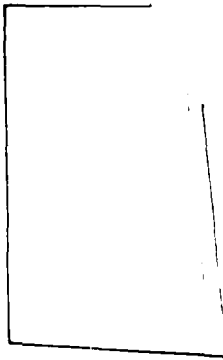

Lake Sherwood

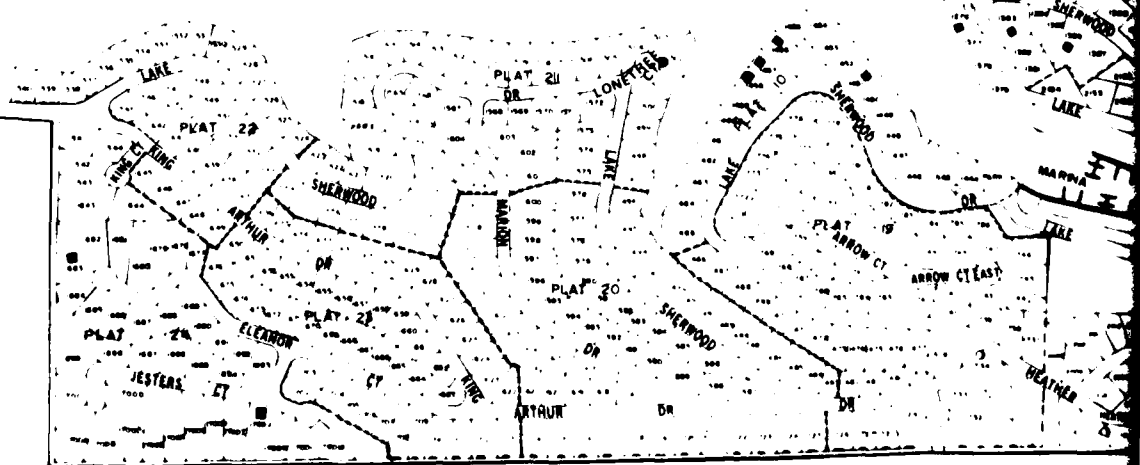

MATCH

L

# LAKE SHERWOOD

## ESTATES

*Warren County Missouri*

MATCH

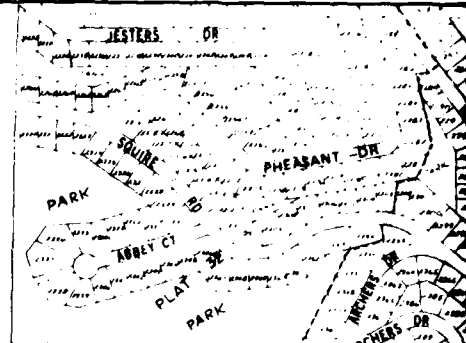

■ Indicates home complete or under construction

*Revised and reproduced by  
John and Birdie  
and Roy Se...*

LEWIS & ASSOC

WARRENTON, MO

Scale 1"=660 Feet

LAKE SHERWOOD  
SUBDIVISION

LINE

2

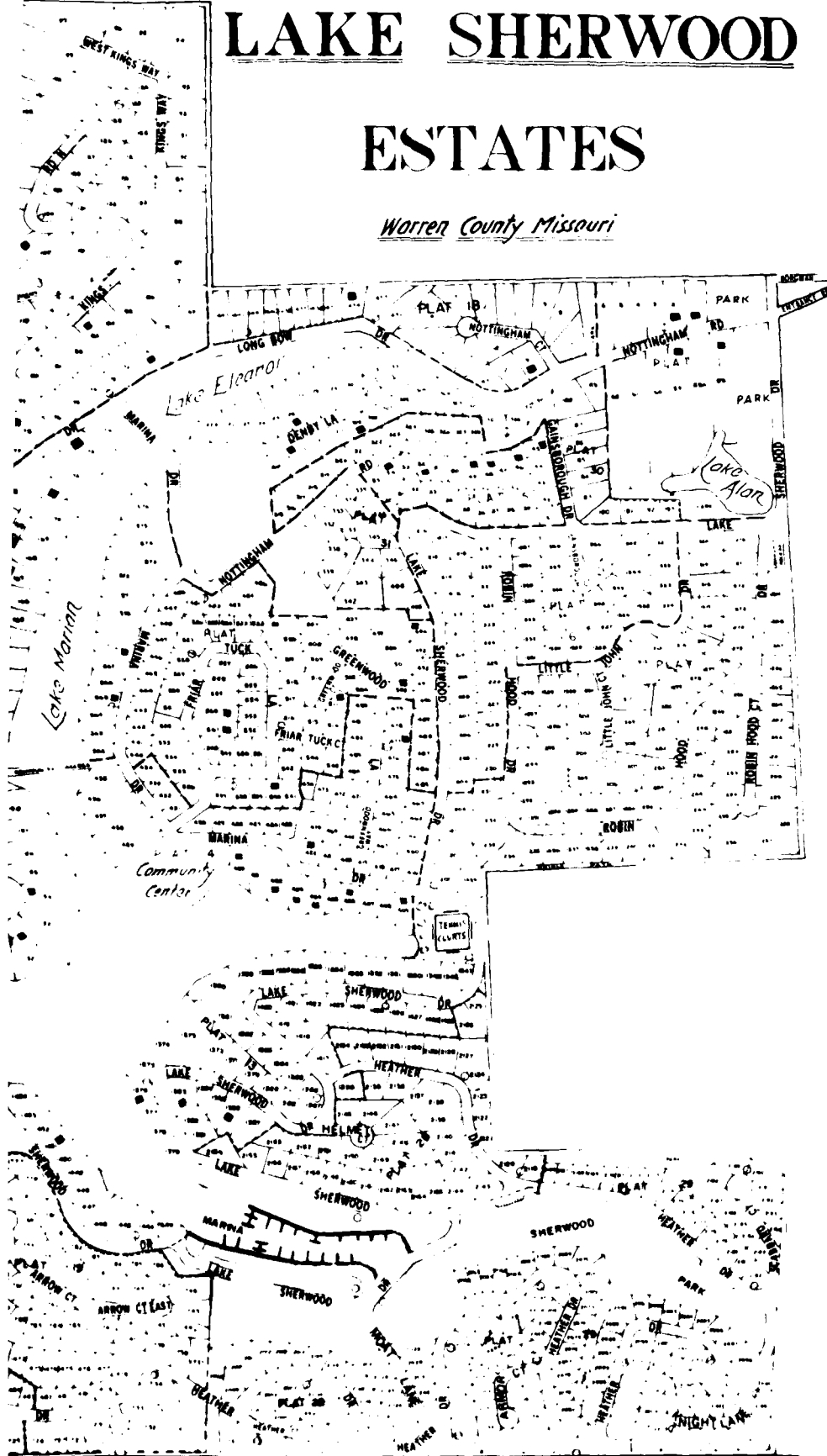

MATCH LINE

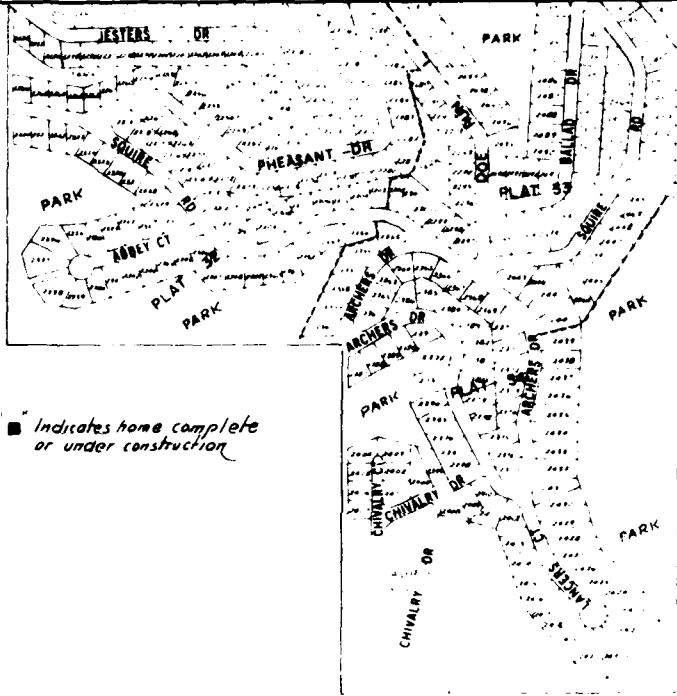

■ Indicates home complete or under construction



*Revised and reproduced by  
John and Birdie Wunnenberg  
and Roy Schmitt*

LEWIS & ASSOCIATES	
WARRENTON, MO	

Scale: 1"=660 feet

LAKE SHERWOOD ESTATES  
SUBDIVISION PLAT

13

PLATE 2

A=APPROXIMATE EXTENT OF FLOOD DAMAGE ZONE

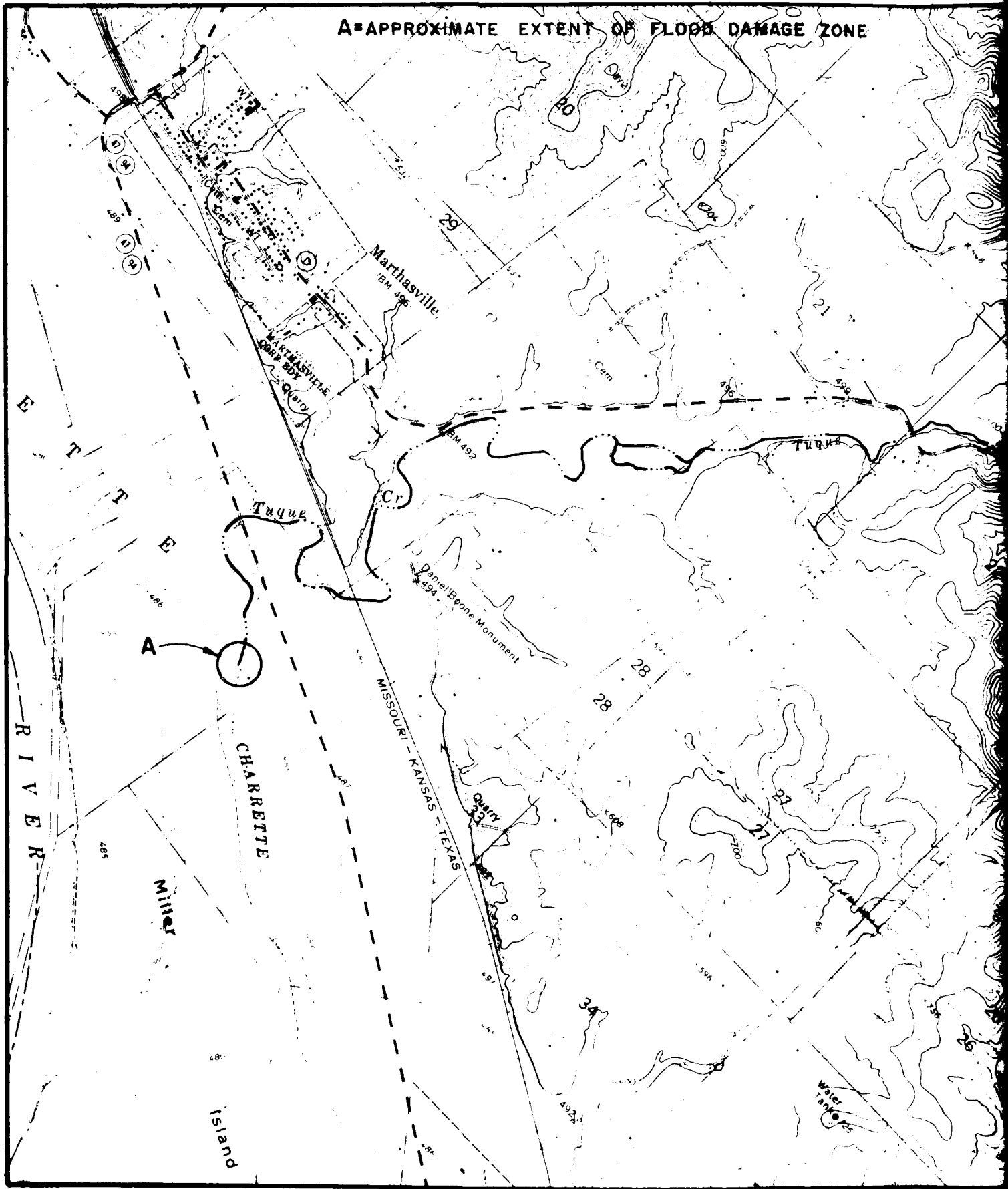

ZONE

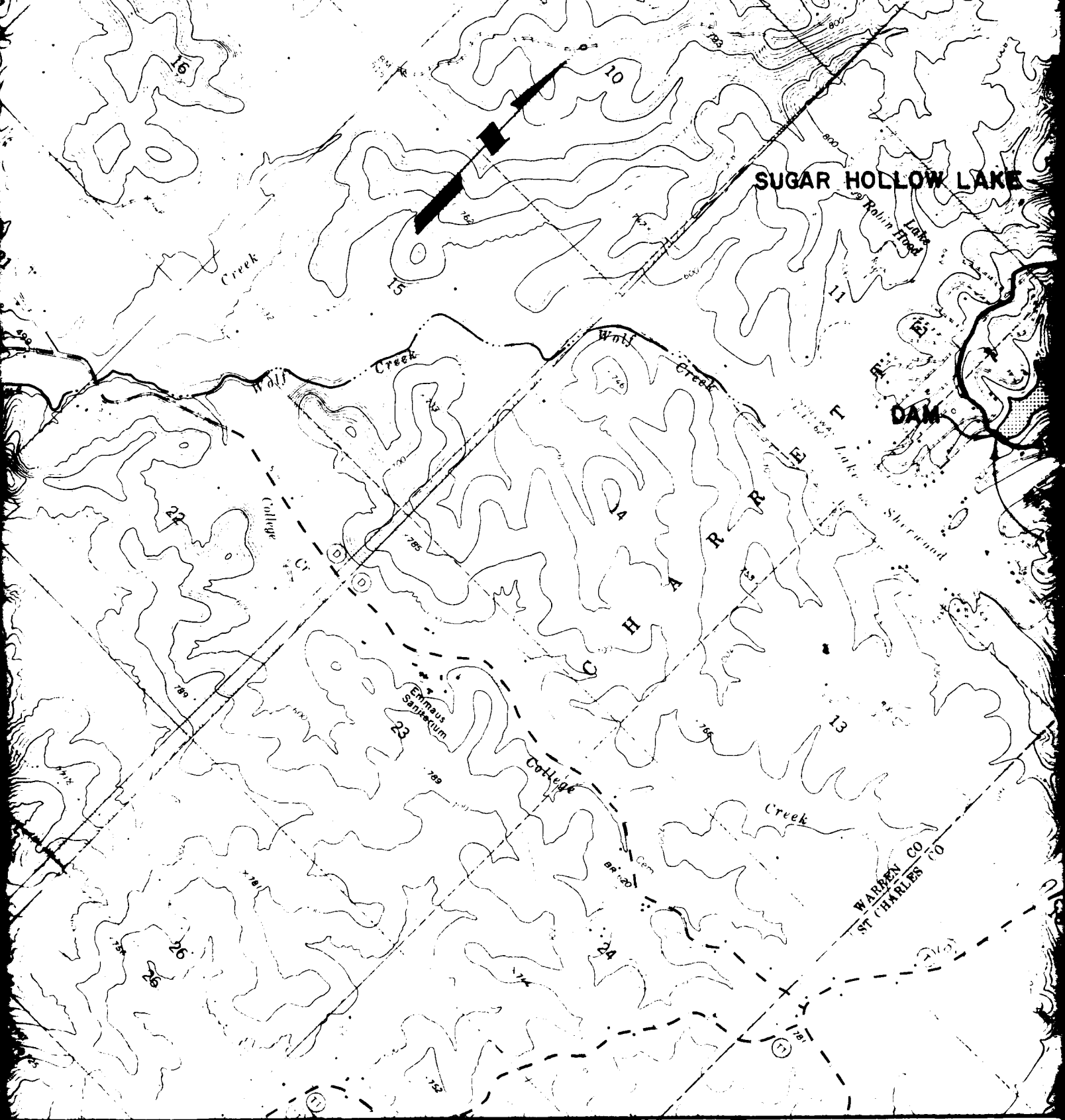

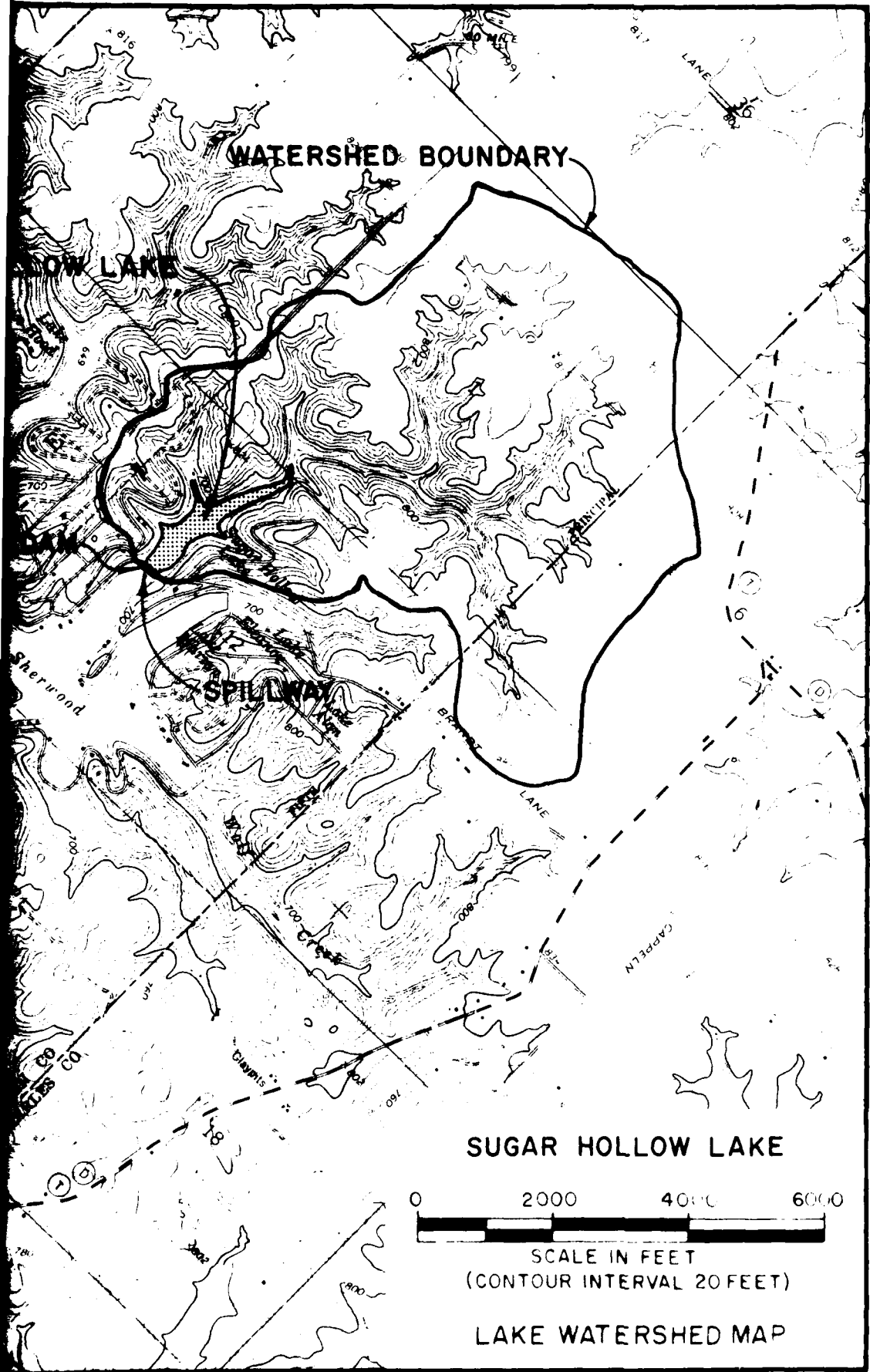

**SUGAR HOLLOW LAKE**



SCALE IN FEET  
(CONTOUR INTERVAL 20 FEET)

LAKE WATERSHED MAP

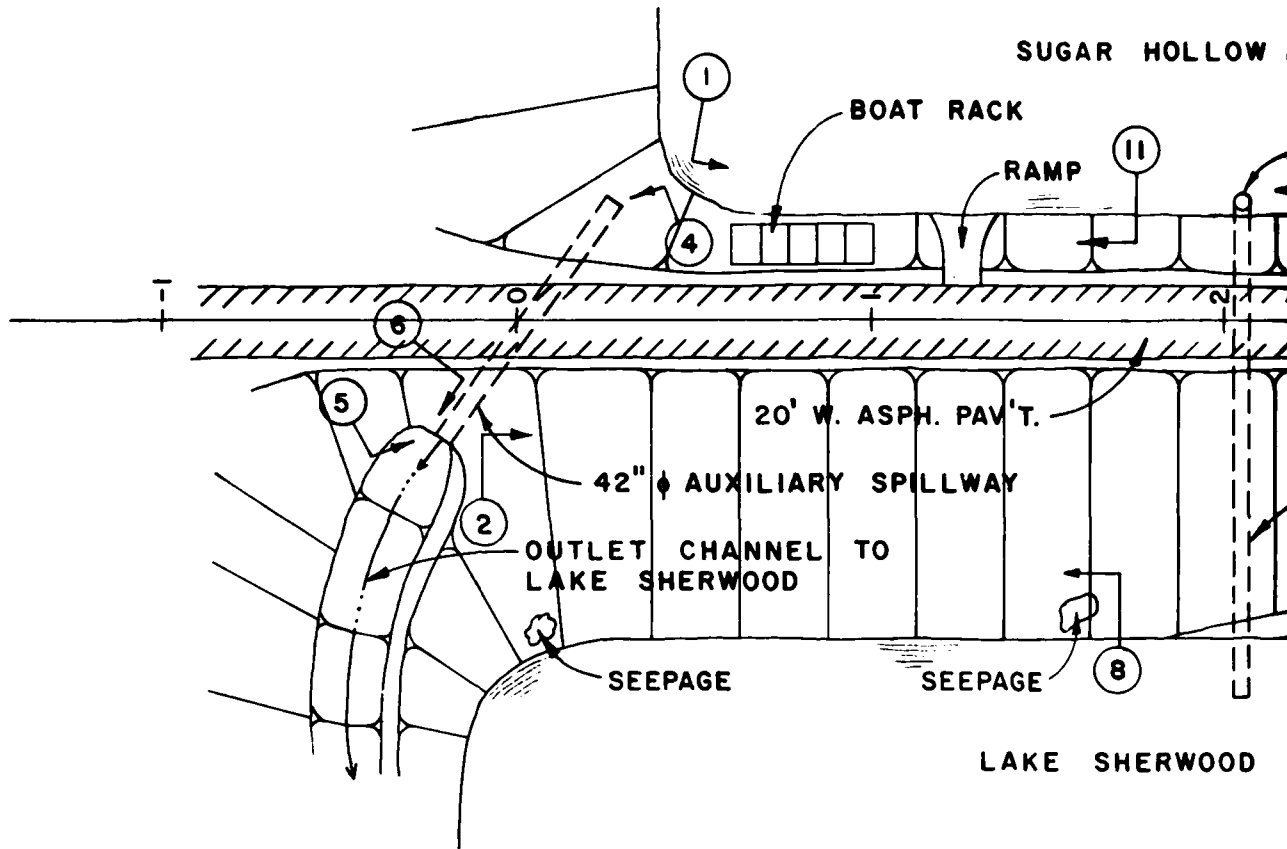

**GENERAL PLAN**  
SCALE: 1" = 20'

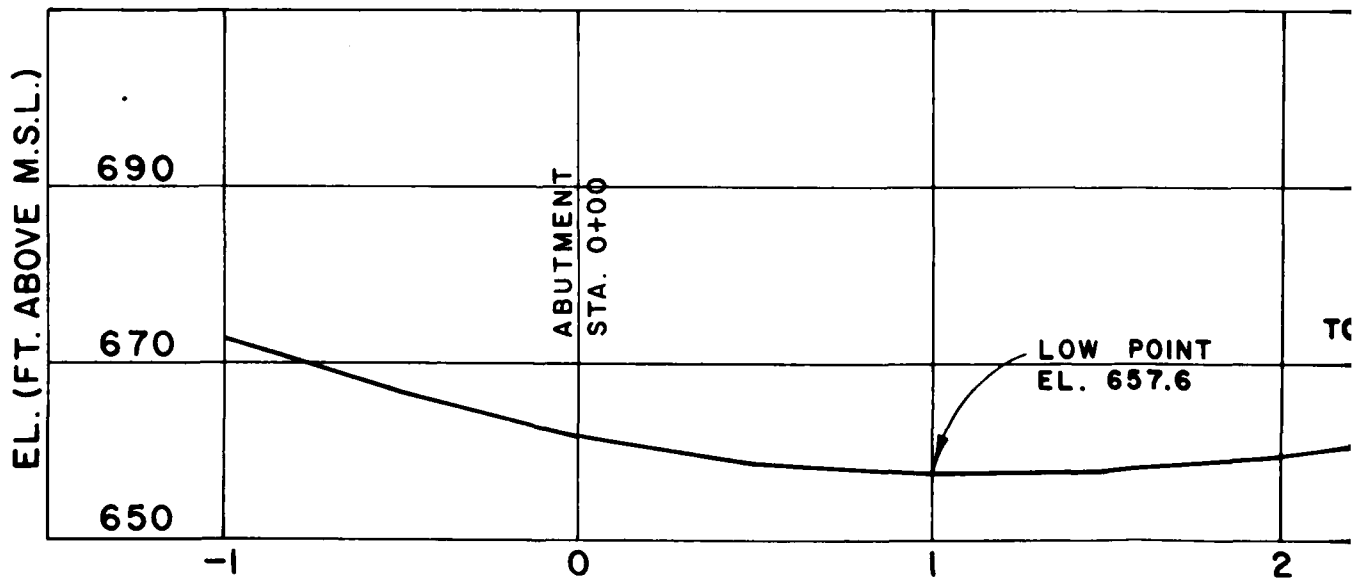

**PROFILE DAM**  
SCALE: 1" = 20' V., 1" = 20' H.

  
 PHOTO LOCATION & KEY  
 (SEE APPENDIX A)

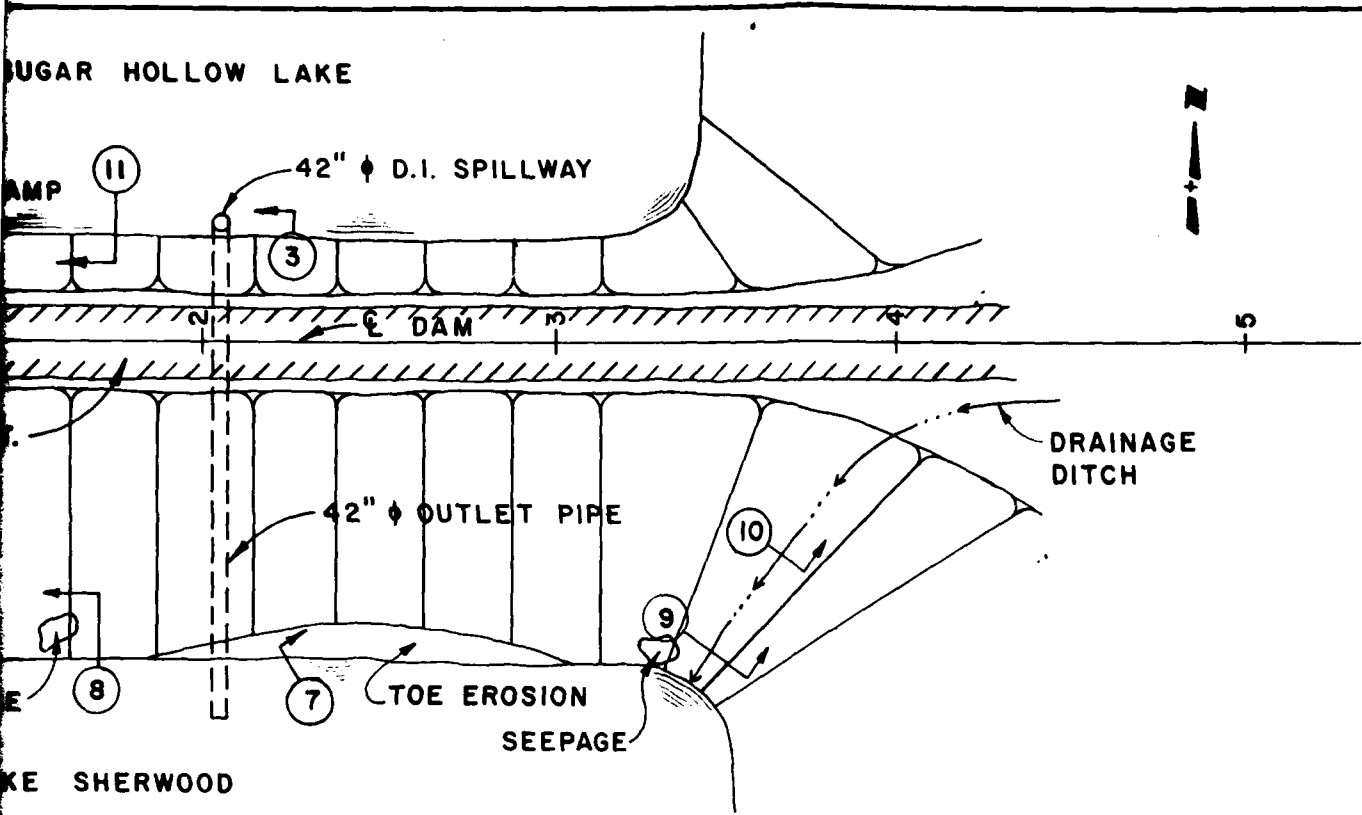

**GENERAL PLAN OF DAM**  
SCALE: 1"=50'

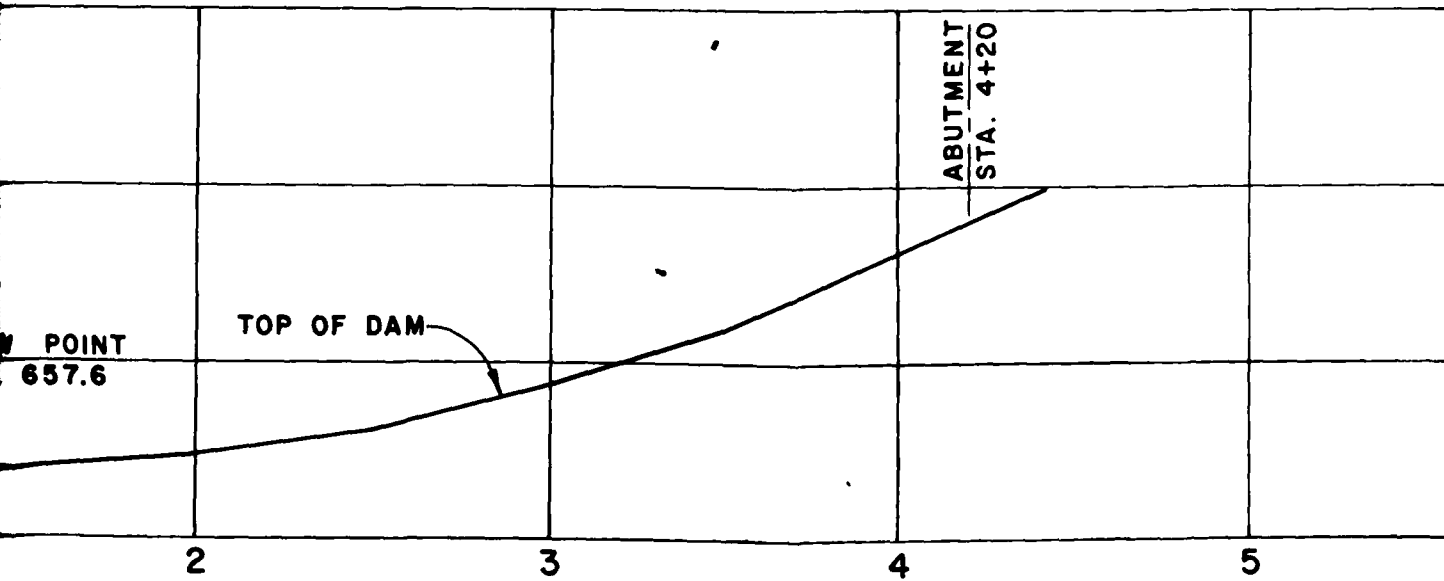

**PROFILE DAM CREST**  
SCALE: 1"=20' V., 1"=50' H.

SUGAR HOLLOW LAKE  
DAM PLAN & PROFILE

Horner & Shifrin, Inc. July 1980

17

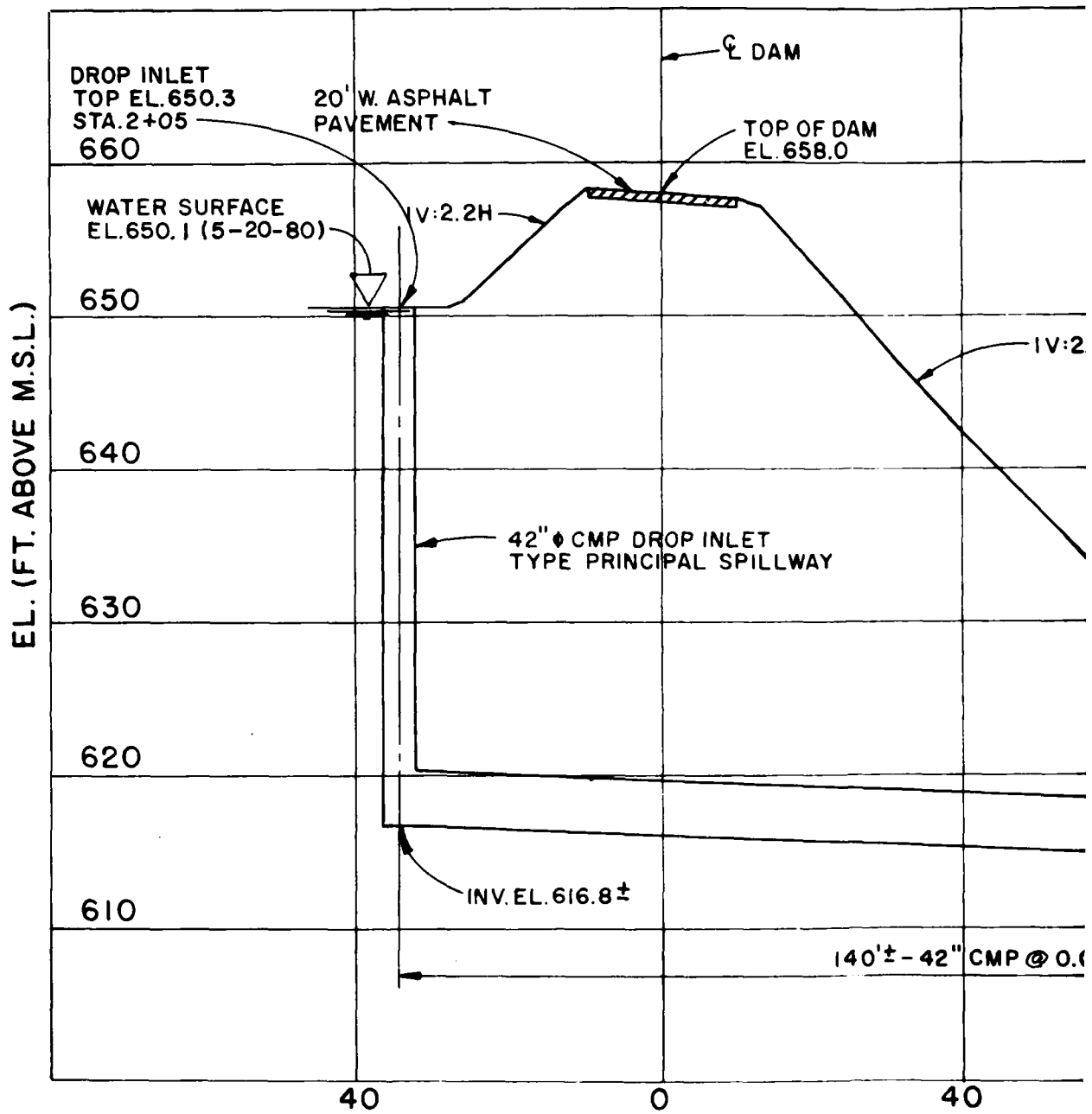

**DAM CROSS-SECTION S-S**  
 SCALE: 1" = 10' V., 1" = 20'

- NOTES:**
1. NORMAL POOL LAKE SHERWOOD = EL. 622.8
  2. SPILLWAY PROFILE SUPERIMPOSED ON DAM SECTION, ACTUAL LOCATION OF OUTLET AS NOTED.

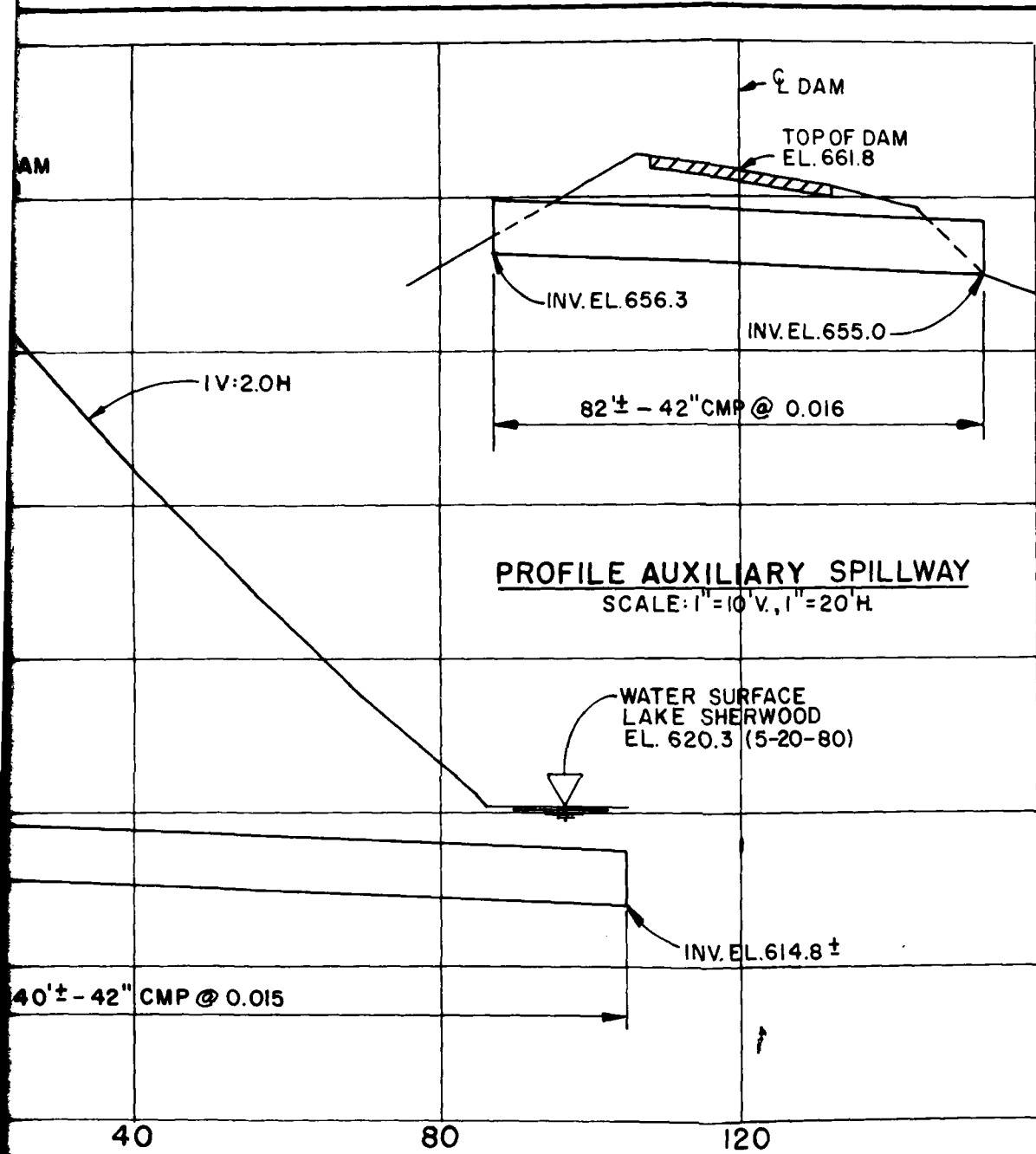

**CROSS-SECTION STA. 1+50**  
SCALE: 1" = 10' V., 1" = 20' H.

SUGAR HOLLOW LAKE  
DAM CROSS-SECTION &  
SPILLWAY PROFILES  
Horner & Shifrin, Inc.      July 1980

2

APPENDIX A  
INSECTION PHOTOGRAPHS

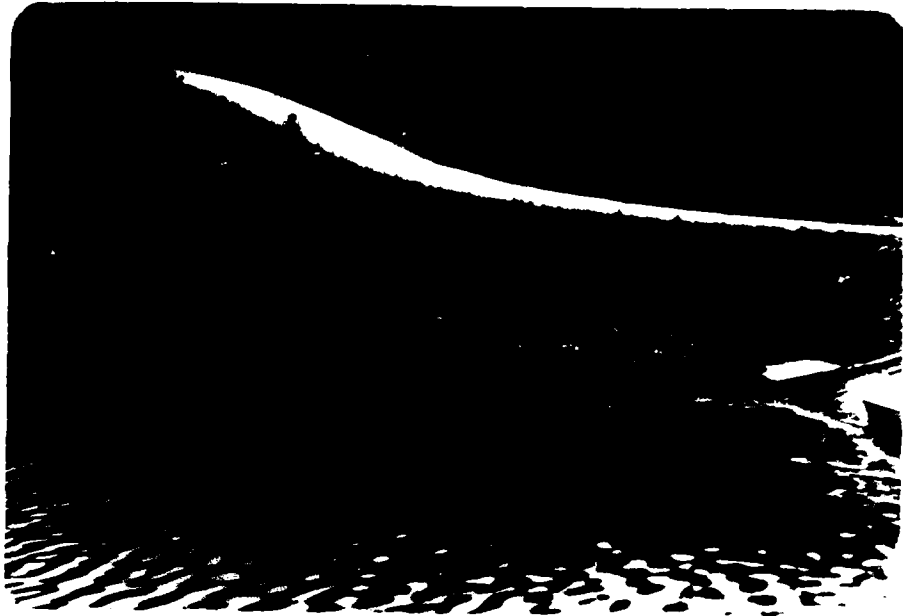

NO. 1: UPSTREAM FACE OF DAM

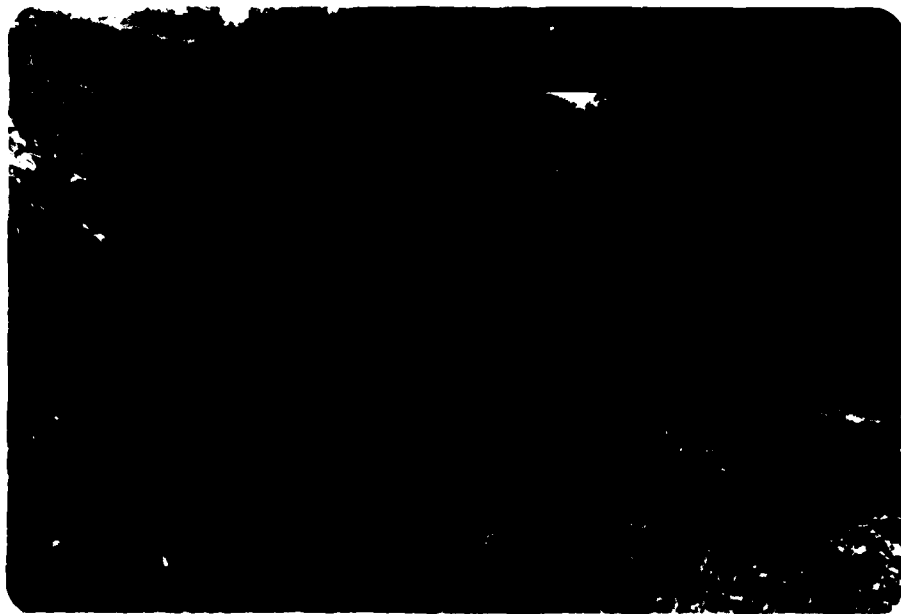

NO. 2: DOWNSTREAM FACE OF DAM



NO. 3: DROP INLET SPILLWAY



NO. 4: UPSTREAM END OF AUXILIARY SPILLWAY LINE



NO. 5: DOWNSTREAM END OF AUXILIARY SPILLWAY PIPE



NO. 6: AUXILIARY SPILLWAY OUTLET CHANNEL



NO. 7: EMBANKMENT EROSION AT DOWNSTREAM TOE

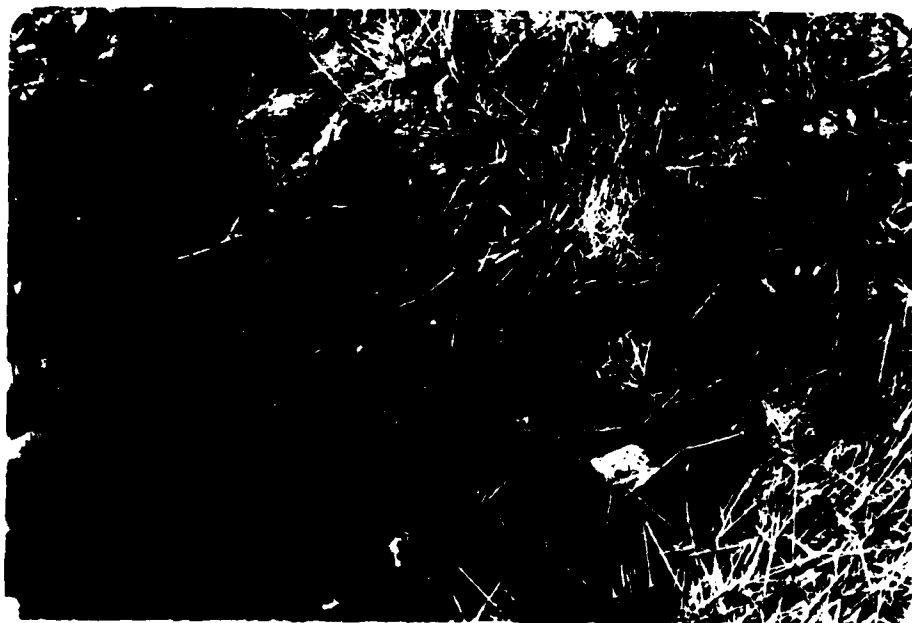

NO. 8: SEEPAGE AT TOE OF SLOPE NEAR CENTER OF DAM



NO. 9: JUNCTION OF DOWNSTREAM FACE OF DAM & EMBANKMENT



NO. 10: EMBANKMENT PORTION AT DAM



NO. 11: DEBRIS AND BOATS AT UPSTREAM FACE OF DAM

APPENDIX B

HYDROLOGIC AND HYDRAULIC ANALYSES

## HYDROLOGIC AND HYDRAULIC COMPUTATIONS

1. The HEC-1 Dam Safety Version (July 1978, Modified 26 February 1979) program was used to develop inflow and outflow hydrographs and dam overtopping analyses, with hydrologic inputs as follows:

- a. Probable maximum precipitation (200 sq. mile, 24-hour value equals 25.1 inches) from Hydrometeorological Report No. 33. The precipitation data used in the analyses of the 1 percent chance (100-year frequency) flood and the 10 percent chance (10-year frequency) flood was provided by the St. Louis District, Corps of Engineers. Due to the fact that the watershed for this reservoir is small, the lake level was assumed to be at normal pool as a result of antecedent storms prior to occurrence of the PMF and the probabilistic storms.
- b. Drainage area = 1.52 square miles = 974 acres.
- c. SCS parameters:

$$\text{Time of Concentration } (T_c) = \frac{11.9L^3}{H}^{0.385} = 0.541 \text{ hours}$$

Where:  $T_c$  = Travel time of water from hydraulically most distant point to point of interest, hours

L = Length of longest watercourse = 1.44 miles

H = Elevation difference = 175 feet

$$\text{Lag Time} = 0.325 \text{ hours } (0.60 T_c)$$

The time of concentration ( $T_c$ ) was obtained using Method C as described in Figure 30, "Design of Small Dams", by the United States Department of the Interior, Bureau of Reclamation, and was verified using average channel velocity estimates and watercourse lengths.

Hydrologic soil group = 30%B, 36%C and 34%D, per SCS County Soil Reports

Soil type CN = 66 (AMC II, 100-yr flood condition)  
= 82 (AMC III, PMF condition)

2. Spillway releases for the drop inlet spillway were computed utilizing equations and nomographs presented in "Design of Small Dams" by the U. S. Department of the Interior (USDI) for drop inlet type spillways. The rise of the nappe above the elevation of the crest lip was considered negligible. The following equation was used for crest control:

$$Q = C_o (2\pi R_s) H_o^{3/2}$$

Where "C<sub>o</sub>" is a coefficient obtained from Figure 283 of the above reference, expressed in terms of H<sub>o</sub>/R<sub>s</sub>, "R<sub>s</sub>" is the radius of the spillway crest (1.75 feet), "H<sub>o</sub>" is the depth of flow over the crest.

When the ratio H<sub>o</sub>/R<sub>s</sub> reached a value of 1.00, inflow was determined by assuming flow was over a sharp edged submerged orifice. The following equation was used:  $Q = Ca (2gh)^{0.5}$ , where "C" is a coefficient assumed to be 0.60, "a" is the area of the orifice 9.62 sf, "h" is the height of flow above the orifice, and "g" is acceleration due to gravity. Reference, "Handbook of Hydraulics", Fifth Edition, by King and Brater, page 4-3.

Flow through the 42-inch diameter corrugated metal pipe outlet was determined using Bernoulli's equation for pressure flow in pipes. Losses, including throat, entrance, pipe and exit losses totaled 3.95 velocity heads. Reference, "Handbook of Hydraulics", Fifth Edition, by King and Brater, pages 8-5 and 8-6.

Discharge quantities, determined by the methods described herein were plotted versus corresponding lake water surface elevations to determine the discharge rating curve for the drop inlet spillway.

3. The auxiliary spillway consists of a 42-inch diameter corrugated metal pipe extending through the dam at the right abutment. Spillway release rates were determined as follows:

For low flows, inflow was determined by assuming flow was through a sharp edged orifice, as indicated in paragraph 2, above.

For higher flows, inflow was governed by Bernoulli's equation for pressure flow in pipes. Losses, including entrance, pipe and exit losses, totaled 2.73 velocity heads.

Discharge quantities, as computed above, were plotted versus corresponding lake water surface elevations to determine the discharge rating curve for the auxiliary spillway.

4. The discharge for the principal and auxiliary spillways for equal elevations were summed for entry on the Y4 and Y5 cards.

5. The profile of the dam crest is irregular and flow over the dam cannot be determined by application of conventional weir formulas. Crest length and elevation data for the dam crest proper were entered into the HEC-1 Program on the SL and the SV cards. The program assumes that flow over the dam crest section occurs at critical depth and computes internally the flow over the dam crest and adds this flow to the flow passing the spillways as entered on the Y4 and Y5 cards.

ANALYSIS OF DAM OVERTOPPING USING RATIOS OF PMF  
 HYDROLOGIC-HYDRAULIC ANALYSIS OF SAFETY OF SUGAR HOLLOW LAKE DAM  
 RATIOS OF PMF ROUTED THROUGH RESERVOIR

	0	5	0	0	0	0	0	0	0
A1	288	0	5	0	0	0	0	0	0
A2	5								
A3	1	4	1						
B	0.08	0.09	0.50	1.00					
B1	0	INFLOW		1					
J	1	INFLOW HYDROGRAPH							
J1	2	1.522		1.0					
K	0								
K1	1	25.1	102	120	130				
M	0								
P	0	0.325							
T		-1.0	-0.10	2.0					
W2		DAM							
X	1	RESERVOIR ROUTING BY MODIFIED PULS							
K	1								
K1									
Y									
Y1	1								
Y4	650.3	651.3	653.0	654.4	655.3	656.3	658.0	660.0	661.8
Y4	664.0	665.0	666.0	667.0	668.0	669.0	670.0	670.0	663.0
Y5	0	35.2	70.0	93.5	103.6	114.0	159.0	209.0	246.4
Y5	278.7	291.8	305.1	316.8	329.0	340.2	351.2		264.8
\$A	0	16.5	22.0	28.5	35.8				
\$E	618.0	650.3	660	670	680				
\$S	650.3								
\$D	657.6								
\$L	0	68	123	163	243	255	342	357	442
\$V	657.6	658.0	658.7	659.5	661.8	662.2	666.6	667.4	673.0
K	99								





1A1 ANALYSIS OF DAM OVERTOPPING USING 10-YR FLOOD  
 A2 HYDROLOGIC-HYDRAULIC ANALYSIS OF SAFETY OF SUGAR HOLLOW LAKE DAM  
 A3 10-YR FLOOD ROUTED THROUGH RESERVOIR

	240	5	1	1	4
B	0	6			
B1	5				
J	1	1			
J1	1.00				
K	0	INFLOW			
K1	0	INFLOW HYDROGRAPH			
M	0	2	1.522	1.0	1
D	240	5.040			
G1	.066	.006	.006	.006	.006
G1	.006	.006	.006	.006	.006
G1	.006	.006	.006	.006	.006
G1	.006	.006	.006	.006	.006
G1	.006	.006	.006	.006	.006
G1	.006	.006	.006	.006	.006
G1	.012	.012	.012	.012	.012
G1	.012	.012	.012	.012	.012
G1	.012	.012	.012	.012	.012
G1	.018	.018	.018	.018	.018
G1	.018	.018	.018	.018	.018
G1	.057	.057	.057	.057	.057
G1	.190	.190	.190	.190	.190
G1	.637	.637	.637	.637	.637
G1	.018	.018	.018	.018	.018
G1	.012	.012	.012	.012	.012
G1	.012	.012	.012	.012	.012
G1	.012	.012	.012	.012	.012
G1	.006	.006	.006	.006	.006
G1	.006	.006	.006	.006	.006
G1	.006	.006	.006	.006	.006
G1	.006	.006	.006	.006	.006



ANALYSIS OF DAM OVERTOPPING USING RATIOS OF PMF  
 HYDROLOGIC-HYDRAULIC ANALYSIS OF SAFETY OF SUGAR HOLLOW LAKE DAM  
 RATIOS OF PMF ROUTED THROUGH RESERVOIR

JOB SPECIFICATION

NO	NHR	NMIN	IDAY	IHR	IMIN	METRC	IPLT	IFRT	NSTAN
288	0	5	0	0	0	0	0	0	0
			JOPER	HWT	LROPT	TRACE			
			5	0	0	0			

MULTI-PLAN ANALYSES TO BE PERFORMED  
 NPLAN= 1 NRTIO= 4 LRTIO= 1  
 RTIOS= .08 .09 .50 1.00

\*\*\*\*\*

SUB-AREA RUNOFF COMPUTATION

INFLOW HYDROGRAPH

ISTAR	ICOMP	IECON	ITAFE	JPLT	JFRT	INAME	ISTAGE	IAUTO
INFLOW	0	0	0	0	0	1	0	0

HYDROGRAPH DATA

IHYD	IUNG	TAREA	SNAP	TRSDA	TRSPC	RATIO	ISNOW	ISAME	LOCAL
1	2	1.52	0.00	1.52	1.00	0.000	0	1	0

PRECIP DATA

SFFE	PMS	R6	R12	R24	R48	R72	R96
0.00	25.10	102.00	120.00	130.00	0.00	0.00	0.00

LOSS DATA

LROPT	STRKR	DLTKR	RTIOL	ERAIN	STRKS	RTIOK	STRTL	CNSTL	ALSMX	RTIMP
0	0.00	0.00	1.00	0.00	0.00	1.00	-1.00	-82.00	0.00	0.00

CURVE NO = -82.00 WETNESS = -1.00 EFFECT CN = 82.00

UNIT HYDROGRAPH DATA

TC= 0.00 LAG= .33

RECESSION DATA

STRTO= -1.00 GRCSN= -.10 RTIOR= 2.00

UNIT HYDROGRAPH 21 END OF PERIOD ORDINATES, TC= 0.00 HOURS, LAG= .33 VOL= 1.00

249.	796.	1584.	1985.	1939.	1620.	1143.	759.	526.	371.
254.	176.	120.	83.	57.	40.	27.	20.	14.	9.
5.									

0							END-OF-PERIOD FLOW						
MO. DA	HR. MN	PERIOD	RAIN	EXCS	LOSS	COMP Q	MO. DA	HR. MN	PERIOD	RAIN	EXCS	LOSS	COMP Q
1.01	.05	1	.01	0.00	.01	1.	1.01	12.05	145	.21	.19	.02	701.
1.01	.10	2	.01	0.00	.01	1.	1.01	12.10	146	.21	.20	.02	812.
1.01	.15	3	.01	0.00	.01	1.	1.01	12.15	147	.21	.20	.02	1032.
1.01	.20	4	.01	0.00	.01	1.	1.01	12.20	148	.21	.20	.02	1306.
1.01	.25	5	.01	0.00	.01	1.	1.01	12.25	149	.21	.20	.02	1580.
1.01	.30	6	.01	0.00	.01	1.	1.01	12.30	150	.21	.20	.01	1809.
1.01	.35	7	.01	0.00	.01	1.	1.01	12.35	151	.21	.20	.01	1974.
1.01	.40	8	.01	0.00	.01	1.	1.01	12.40	152	.21	.20	.01	2086.
1.01	.45	9	.01	0.00	.01	1.	1.01	12.45	153	.21	.20	.01	2167.
1.01	.50	10	.01	0.00	.01	1.	1.01	12.50	154	.21	.20	.01	2227.
1.01	.55	11	.01	0.00	.01	1.	1.01	12.55	155	.21	.20	.01	2269.
1.01	1.00	12	.01	0.00	.01	1.	1.01	13.00	156	.21	.20	.01	2301.
1.01	1.05	13	.01	0.00	.01	1.	1.01	13.05	157	.26	.24	.01	2335.
1.01	1.10	14	.01	0.00	.01	1.	1.01	13.10	158	.26	.24	.01	2386.
1.01	1.15	15	.01	0.00	.01	1.	1.01	13.15	159	.26	.24	.01	2435.
1.01	1.20	16	.01	0.00	.01	1.	1.01	13.20	160	.26	.25	.01	2558.
1.01	1.25	17	.01	0.00	.01	0.	1.01	13.25	161	.26	.25	.01	2647.
1.01	1.30	18	.01	0.00	.01	0.	1.01	13.30	162	.26	.25	.01	2722.
1.01	1.35	19	.01	0.00	.01	0.	1.01	13.35	163	.26	.25	.01	2777.
1.01	1.4	20	.01	0.00	.01	0.	1.01	13.40	164	.26	.25	.01	2815.
1.01	1.45	21	.01	0.00	.01	0.	1.01	13.45	165	.26	.25	.01	2843.
1.01	1.50	22	.01	0.00	.01	0.	1.01	13.50	166	.26	.25	.01	2883.
1.01	1.55	23	.01	0.00	.01	0.	1.01	13.55	167	.26	.25	.01	2923.
1.01	2.00	24	.01	0.00	.01	0.	1.01	14.00	168	.26	.25	.01	2991.
1.01	2.05	25	.01	0.00	.01	0.	1.01	14.05	169	.32	.31	.01	2918.
1.01	2.10	26	.01	0.00	.01	0.	1.01	14.10	170	.32	.31	.01	2973.
1.01	2.15	27	.01	0.00	.01	0.	1.01	14.15	171	.32	.31	.01	3029.
1.01	2.20	28	.01	0.00	.01	0.	1.01	14.20	172	.32	.31	.01	3086.
1.01	2.25	29	.01	0.00	.01	0.	1.01	14.25	173	.32	.31	.01	3034.
1.01	2.30	30	.01	0.00	.01	0.	1.01	14.30	174	.32	.31	.01	3450.
1.01	2.35	31	.01	0.00	.01	0.	1.01	14.35	175	.32	.31	.01	2516.
1.01	2.40	32	.01	.00	.01	0.	1.01	14.40	176	.32	.31	.01	3568.
1.01	2.45	33	.01	.00	.01	0.	1.01	14.45	177	.32	.31	.01	3605.
1.01	2.50	34	.01	.00	.01	0.	1.01	14.50	178	.32	.31	.01	3632.
1.01	2.55	35	.01	.00	.01	1.	1.01	14.55	179	.32	.31	.01	3652.
1.01	3.00	36	.01	.00	.01	2.	1.01	15.00	180	.32	.31	.01	3666.
1.01	3.05	37	.01	.00	.01	3.	1.01	15.05	181	.19	.16	.05	3646.
1.01	3.10	38	.01	.00	.01	4.	1.01	15.10	182	.32	.32	.01	3604.
1.01	3.15	39	.01	.00	.01	6.	1.01	15.15	183	.32	.32	.01	3567.
1.01	3.20	40	.01	.00	.01	7.	1.01	15.20	184	.58	.58	.01	3629.
1.01	3.25	41	.01	.00	.01	9.	1.01	15.25	185	.68	.67	.01	4000.
1.01	3.30	42	.01	.00	.01	11.	1.01	15.30	186	1.65	1.63	.02	4795.
1.01	3.35	43	.01	.00	.01	13.	1.01	15.35	187	2.72	2.70	.03	6532.
1.01	3.40	44	.01	.00	.01	14.	1.01	15.40	188	1.07	1.06	.01	9134.
1.01	3.45	45	.01	.00	.01	16.	1.01	15.45	189	.68	.67	.01	11960.
1.01	3.50	46	.01	.00	.01	18.	1.01	15.50	190	.58	.58	.00	13445.

END-OF-PERIOD FLOW (Con't.)

1.01	3.55	47	.01	.00	.01	20.	1.01	15.55	191	.38	.39	.00	12330.
1.01	4.00	48	.01	.00	.01	21.	1.01	16.00	192	.39	.39	.00	12152.
1.01	4.05	49	.01	.00	.01	23.	1.01	16.05	193	.39	.39	.00	10332.
1.01	4.10	50	.01	.00	.01	25.	1.01	16.10	194	.39	.39	.00	8609.
1.01	4.15	51	.01	.00	.01	26.	1.01	16.15	195	.39	.39	.00	7239.
1.01	4.20	52	.01	.00	.01	28.	1.01	16.20	196	.39	.39	.00	5168.
1.01	4.25	53	.01	.00	.01	29.	1.01	16.25	197	.39	.39	.00	5302.
1.01	4.30	54	.01	.00	.01	31.	1.01	16.30	198	.39	.39	.00	4785.
1.01	4.35	55	.01	.00	.01	32.	1.01	16.35	199	.39	.39	.00	4382.
1.01	4.40	56	.01	.00	.01	34.	1.01	16.40	200	.39	.39	.00	4107.
1.01	4.45	57	.01	.00	.01	35.	1.01	16.45	201	.39	.39	.00	3920.
1.01	4.50	58	.01	.00	.01	37.	1.01	16.50	202	.39	.39	.00	3790.
1.01	4.55	59	.01	.00	.01	38.	1.01	16.55	203	.39	.39	.00	3700.
1.01	5.00	60	.01	.00	.01	40.	1.01	17.00	204	.39	.39	.00	3640.
1.01	5.05	61	.01	.00	.01	41.	1.01	17.05	205	.23	.23	.00	3580.
1.01	5.10	62	.01	.00	.01	42.	1.01	17.10	206	.23	.23	.00	3495.
1.01	5.15	63	.01	.00	.01	44.	1.01	17.15	207	.23	.23	.00	3367.
1.01	5.20	64	.01	.00	.01	45.	1.01	17.20	208	.23	.23	.00	3221.
1.01	5.25	65	.01	.00	.01	46.	1.01	17.25	209	.23	.23	.00	3090.
1.01	5.30	66	.01	.00	.01	47.	1.01	17.30	210	.23	.23	.00	2933.
1.01	5.35	67	.01	.00	.01	49.	1.01	17.35	211	.23	.23	.00	2908.
1.01	5.40	68	.01	.00	.01	50.	1.01	17.40	212	.23	.23	.00	2859.
1.01	5.45	69	.01	.00	.01	51.	1.01	17.45	213	.23	.23	.00	2826.
1.01	5.50	70	.01	.00	.01	52.	1.01	17.50	214	.23	.23	.00	2802.
1.01	5.55	71	.01	.00	.01	53.	1.01	17.55	215	.23	.23	.00	2788.
1.01	6.00	72	.01	.01	.01	55.	1.01	18.00	216	.23	.23	.00	2775.
1.01	6.05	73	.06	.02	.04	60.	1.01	18.05	217	.02	.02	.00	2715.
1.01	6.10	74	.06	.03	.04	77.	1.01	18.10	218	.02	.02	.00	2540.
1.01	6.15	75	.06	.03	.04	109.	1.01	18.15	219	.02	.02	.00	2360.
1.01	6.20	76	.06	.03	.03	152.	1.01	18.20	220	.02	.02	.00	1775.
1.01	6.25	77	.06	.03	.03	196.	1.01	18.25	221	.02	.02	.00	1381.
1.01	6.30	78	.06	.03	.03	237.	1.01	18.30	222	.02	.02	.00	1259.
1.01	6.35	79	.06	.03	.03	271.	1.01	18.35	223	.02	.02	.00	1174.
1.01	6.40	80	.06	.03	.03	299.	1.01	18.40	224	.02	.02	.00	1096.
1.01	6.45	81	.06	.03	.03	323.	1.01	18.45	225	.02	.02	.00	1022.
1.01	6.50	82	.06	.04	.03	344.	1.01	18.50	226	.02	.02	.00	954.
1.01	6.55	83	.06	.04	.03	363.	1.01	18.55	227	.02	.02	.00	890.
1.01	7.00	84	.06	.04	.02	380.	1.01	19.00	228	.02	.02	.00	830.
1.01	7.05	85	.06	.04	.02	395.	1.01	19.05	229	.02	.02	.00	775.
1.01	7.10	86	.06	.04	.02	409.	1.01	19.10	230	.02	.02	.00	723.
1.01	7.15	87	.06	.04	.02	422.	1.01	19.15	231	.02	.02	.00	675.
1.01	7.20	88	.06	.04	.02	434.	1.01	19.20	232	.02	.02	.00	629.
1.01	7.25	89	.06	.04	.02	445.	1.01	19.25	233	.02	.02	.00	587.
1.01	7.30	90	.06	.04	.02	456.	1.01	19.30	234	.02	.02	.00	548.
1.01	7.35	91	.06	.04	.02	466.	1.01	19.35	235	.02	.02	.00	511.
1.01	7.40	92	.06	.04	.02	475.	1.01	19.40	236	.02	.02	.00	477.
1.01	7.45	93	.06	.04	.02	484.	1.01	19.45	237	.02	.02	.00	445.
1.01	7.50	94	.06	.04	.02	493.	1.01	19.50	238	.02	.02	.00	415.
1.01	7.55	95	.06	.05	.02	501.	1.01	19.55	239	.02	.02	.00	387.
1.01	8.00	96	.06	.05	.02	508.	1.01	20.00	240	.02	.02	.00	361.
1.01	8.05	97	.06	.05	.02	515.	1.01	20.05	241	.02	.02	.00	337.
1.01	8.10	98	.06	.05	.02	522.	1.01	20.10	242	.02	.02	.00	315.
1.01	8.15	99	.06	.05	.02	529.	1.01	20.15	243	.02	.02	.00	294.
1.01	8.20	100	.06	.05	.02	535.	1.01	20.20	244	.02	.02	.00	274.

END-OF-PERIOD FLOW (Con't.)

1.01	8.25	101	.06	.05	.01	541.	1.01	20.25	245	.02	.02	.00	256.
1.01	8.30	102	.06	.05	.01	547.	1.01	20.30	246	.02	.02	.00	245.
1.01	8.35	103	.06	.05	.01	552.	1.01	20.35	247	.02	.02	.00	245.
1.01	8.40	104	.06	.05	.01	558.	1.01	20.40	248	.02	.02	.00	245.
1.01	8.45	105	.06	.05	.01	563.	1.01	20.45	249	.02	.02	.00	245.
1.01	8.50	106	.06	.05	.01	568.	1.01	20.50	250	.02	.02	.00	245.
1.01	8.55	107	.06	.05	.01	572.	1.01	20.55	251	.02	.02	.00	245.
1.01	9.00	108	.06	.05	.01	577.	1.01	21.00	252	.02	.02	.00	245.
1.01	9.05	109	.06	.05	.01	581.	1.01	21.05	253	.02	.02	.00	245.
1.01	9.10	110	.06	.05	.01	585.	1.01	21.10	254	.02	.02	.00	245.
1.01	9.15	111	.06	.05	.01	589.	1.01	21.15	255	.02	.02	.00	245.
1.01	9.20	112	.06	.05	.01	593.	1.01	21.20	256	.02	.02	.00	245.
1.01	9.25	113	.06	.05	.01	597.	1.01	21.25	257	.02	.02	.00	245.
1.01	9.30	114	.06	.05	.01	600.	1.01	21.30	258	.02	.02	.00	245.
1.01	9.35	115	.06	.05	.01	603.	1.01	21.35	259	.02	.02	.00	245.
1.01	9.40	116	.06	.05	.01	607.	1.01	21.40	260	.02	.02	.00	245.
1.01	9.45	117	.06	.05	.01	610.	1.01	21.45	261	.02	.02	.00	245.
1.01	9.50	118	.06	.05	.01	613.	1.01	21.50	262	.02	.02	.00	245.
1.01	9.55	119	.06	.05	.01	616.	1.01	21.55	263	.02	.02	.00	245.
1.01	10.00	120	.06	.05	.01	619.	1.01	22.00	264	.02	.02	.00	245.
1.01	10.05	121	.06	.05	.01	621.	1.01	22.05	265	.02	.02	.00	245.
1.01	10.10	122	.06	.05	.01	624.	1.01	22.10	266	.02	.02	.00	245.
1.01	10.15	123	.06	.05	.01	627.	1.01	22.15	267	.02	.02	.00	245.
1.01	10.20	124	.06	.05	.01	629.	1.01	22.20	268	.02	.02	.00	245.
1.01	10.25	125	.06	.05	.01	632.	1.01	22.25	269	.02	.02	.00	245.
1.01	10.30	126	.06	.05	.01	634.	1.01	22.30	270	.02	.02	.00	245.
1.01	10.35	127	.06	.05	.01	636.	1.01	22.35	271	.02	.02	.00	245.
1.01	10.40	128	.06	.05	.01	638.	1.01	22.40	272	.02	.02	.00	245.
1.01	10.45	129	.06	.06	.01	640.	1.01	22.45	273	.02	.02	.00	245.
1.01	10.50	130	.06	.06	.01	642.	1.01	22.50	274	.02	.02	.00	245.
1.01	10.55	131	.06	.06	.01	644.	1.01	22.55	275	.02	.02	.00	245.
1.01	11.00	132	.06	.06	.01	646.	1.01	23.00	276	.02	.02	.00	245.
1.01	11.05	133	.06	.06	.01	648.	1.01	23.05	277	.02	.02	.00	245.
1.01	11.10	134	.06	.06	.01	650.	1.01	23.10	278	.02	.02	.00	245.
1.01	11.15	135	.06	.06	.01	652.	1.01	23.15	279	.02	.02	.00	245.
1.01	11.20	136	.06	.06	.01	653.	1.01	23.20	280	.02	.02	.00	245.
1.01	11.25	137	.06	.06	.01	655.	1.01	23.25	281	.02	.02	.00	245.
1.01	11.30	138	.06	.06	.01	657.	1.01	23.30	282	.02	.02	.00	245.
1.01	11.35	139	.06	.06	.01	658.	1.01	23.35	283	.02	.02	.00	245.
1.01	11.40	140	.06	.06	.01	660.	1.01	23.40	284	.02	.02	.00	245.
1.01	11.45	141	.06	.06	.01	661.	1.01	23.45	285	.02	.02	.00	245.
1.01	11.50	142	.06	.06	.01	663.	1.01	23.50	286	.02	.02	.00	245.
1.01	11.55	143	.06	.06	.01	664.	1.01	23.55	287	.02	.02	.00	245.
1.01	12.00	144	.06	.06	.01	665.	1.02	0.00	288	.02	.02	.00	245.

SUM 32.63 30.14 2.49 360790.  
( 829.)( 765.)( 63.)(10216.15)

	PEAK	6-HOUR	24-HOUR	72-HOUR	TOTAL VOLUME
CFS	13445.	4041.	1252.	1252.	360676.
CMS	381.	114.	35.	35.	10213.
INCHES		24.70	30.62	30.62	30.62
MM		627.40	777.67	777.67	777.67
AC-FT		2004.	2484.	2484.	2484.
THOUS CU N		2472.	3064.	3064.	3064.

SURFACE AREA= 0. 17. 22. 29. 36.  
 CAPACITY= 0. 178. 364. 616. 936.  
 ELEVATION= 618. 650. 660. 670. 680.

SUMMARY OF DAM SAFETY ANALYSIS

PMF

INITIAL VALUE SPILLWAY CREST -- TOP OF DAM  
 ELEVATION 650.30 657.60  
 STORAGE 178. 318.  
 OUTFLOW 0. 148.

RATIO OF PMF	MAXIMUM RESERVOIR W.S.ELEV	MAXIMUM DEPTH OVER DAM	MAXIMUM STORAGE AC-FT	MAXIMUM OUTFLOW CFS	DURATION OVER TOP HOURS	TIME OF MAX OUTFLOW HOURS	TIME OF FAILURE HOURS
.08	657.43	0.00	309.	144.	0.00	18.33	0.00
.09	658.13	.53	324.	203.	2.92	18.25	0.00
.50	662.88	5.28	430.	6070.	11.83	16.00	0.00
1.00	665.27	7.67	488.	12617.	13.92	16.00	0.00

SUMMARY OF DAM SAFETY ANALYSIS  
100-YR. FLOOD

ELEVATION	INITIAL VALUE	SPILLWAY CREST	TOP OF DAM		
STORAGE	650.30	650.30	657.60		
OUTFLOW	178.	178.	313.		
	0.	0.	148.		
RATIO OF PMF	MAXIMUM DEPTH OVER DAM	MAXIMUM STORAGE AC-FT.	MAXIMUM OUTFLOW CFS	DURATION OVER TOP HOURS	TIME OF FAILURE HOURS
1.00	658.46	331.	297.	5.90	13.70
					0.00

SUMMARY OF DAM SAFETY ANALYSIS  
10-YR. FLOOD

ELEVATION	INITIAL VALUE	SPILLWAY CREST	TOP OF DAM		
STORAGE	650.30	650.30	657.60		
OUTFLOW	178.	178.	313.		
	0.	0.	148.		
RATIO OF PMF	MAXIMUM DEPTH OVER DAM	MAXIMUM STORAGE AC-FT.	MAXIMUM OUTFLOW CFS	DURATION OVER TOP HOURS	TIME OF FAILURE HOURS
1.00	654.34	258.	98.	0.00	15.30
					0.00