

AD-A104 711

HORNER AND SHIFRIN INC ST LOUIS MO
NATIONAL DAM SAFETY PROGRAM. DEERWOOD LAKE NUMBER 3 DAM (MO 304--ETC(U)
APR 81
DACW43-81-C-0002

F/G 13/13

DACW43-81-C-0002

NL

UNCLASSIFIED

1 of 1
AD A
104711

END
DATE
FORMED
10-81
DTIC

AD A104711

Handwritten marks and stamps at the top of the page.

UPPER MISSISSIPPI - KASKASKIA - ST. LOUIS BASIN

DEERWOOD LAKE NO. 3 DAM
JEFFERSON COUNTY, MISSOURI
MO 30460

PHASE 1 INSPECTION REPORT
NATIONAL DAM SAFETY PROGRAM



United States Army
Corps of Engineers
... Serving the Army
... Serving the Nation

St. Louis District

Handwritten notes and stamps on the right side of the page.

PREPARED BY: U.S. ARMY ENGINEER DISTRICT, ST. LOUIS
FOR: STATE OF MISSOURI

DISTRIBUTION STATEMENT A
Approved for public release;
Distribution Unlimited

APRIL 1981

81 9 28 201

OTC FILE COPY

Handwritten mark at the bottom left corner.

UNCLASSIFIED

SECURITY CLASSIFICATION OF THIS PAGE (When Data Entered)

REPORT DOCUMENTATION PAGE		READ INSTRUCTIONS BEFORE COMPLETING FORM
1. REPORT NUMBER	2. GOVT ACCESSION NO. AD-A104	3. RECIPIENT'S CATALOG NUMBER 711
4. TITLE (and Subtitle) Phase I Dam Inspection Report National Dam Safety Program Deerwood Lake No. 3 Dam (MO 30460) Jefferson County, Missouri		5. TYPE OF REPORT & PERIOD COVERED Final Report.
7. AUTHOR(s) Horner & Shifrin, Inc.		6. PERFORMING ORG. REPORT NUMBER
9. PERFORMING ORGANIZATION NAME AND ADDRESS U.S. Army Engineer District, St. Louis Dam Inventory and Inspection Section, LMSED-PD 210 Tucker Blvd., North, St. Louis, Mo. 63101		8. CONTRACT OR GRANT NUMBER(s) DACW43-81-C-0002 ^{new}
11. CONTROLLING OFFICE NAME AND ADDRESS U.S. Army Engineer District, St. Louis Dam Inventory and Inspection Section, LMSED-PD 210 Tucker Blvd., North, St. Louis, Mo. 63101		10. PROGRAM ELEMENT, PROJECT, TASK AREA & WORK UNIT NUMBERS 12/64
14. MONITORING AGENCY NAME & ADDRESS (if different from Controlling Office) 6 National Dam Safety Program, Deerwood Lake Number 3 Dam (MO 30460), Upper Mississippi - Kaskaskia - St. Louis Basin, Jefferson County, Missouri. Phase I		12. REPORT DATE April 1981
16. DISTRIBUTION STATEMENT Inspection Report. Approved for release; distribution unlimited.		13. NUMBER OF PAGES Approximately 55
17. DISTRIBUTION STATEMENT (of the abstract entered in Block 20, if different from Report)		15. SECURITY CLASS. (of this report) UNCLASSIFIED
18. SUPPLEMENTARY NOTES		15a. DECLASSIFICATION/DOWNGRADING SCHEDULE
19. KEY WORDS (Continue on reverse side if necessary and identify by block number) Dam Safety, Lake, Dam Inspection, Private Dams		
20. ABSTRACT (Continue on reverse side if necessary and identify by block number) This report was prepared under the National Program of Inspection of Non-Federal Dams. This report assesses the general condition of the dam with respect to safety, based on available data and on visual inspection, to determine if the dam poses hazards to human life or property.		

DD FORM 1 JAN 73 1473

EDITION OF 1 NOV 65 IS OBSOLETE

11/2 55

UNCLASSIFIED

SECURITY CLASSIFICATION OF THIS PAGE (When Data Entered)

SECURITY CLASSIFICATION OF THIS PAGE(When Data Entered)

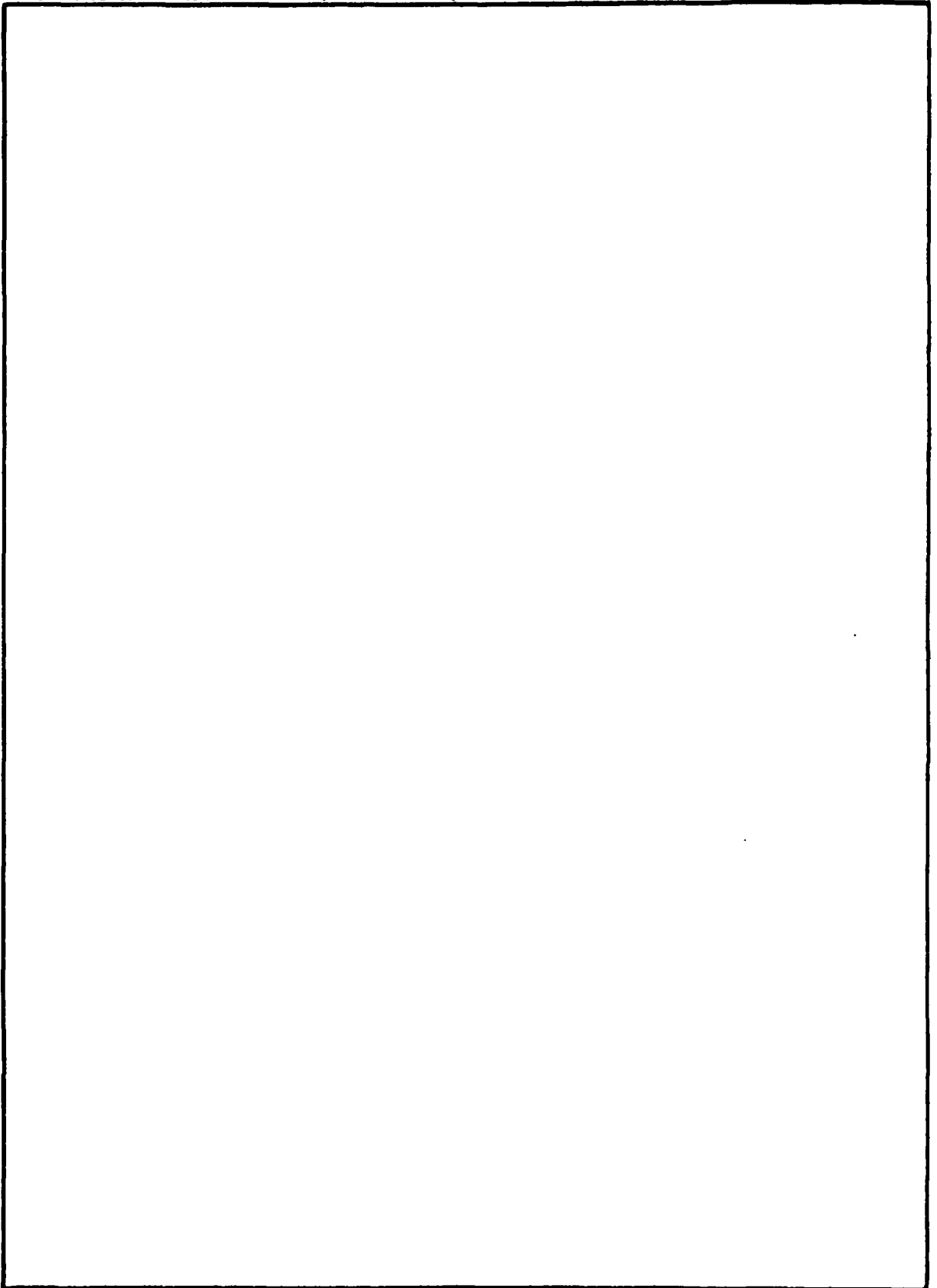

SECURITY CLASSIFICATION OF THIS PAGE(When Data Entered)

INSTRUCTIONS FOR PREPARATION OF REPORT DOCUMENTATION PAGE

RESPONSIBILITY. The controlling DoD office will be responsible for completion of the Report Documentation Page, DD Form 1473, in all technical reports prepared by or for DoD organizations.

CLASSIFICATION. Since this Report Documentation Page, DD Form 1473, is used in preparing announcements, bibliographies, and data banks, it should be unclassified if possible. If a classification is required, identify the classified items on the page by the appropriate symbol.

COMPLETION GUIDE

General. Make Blocks 1, 4, 5, 6, 7, 11, 13, 15, and 16 agree with the corresponding information on the report cover. Leave Blocks 2 and 3 blank.

Block 1. Report Number. Enter the unique alphanumeric report number shown on the cover.

Block 2. Government Accession No. Leave Blank. This space is for use by the Defense Documentation Center.

Block 3. Recipient's Catalog Number. Leave blank. This space is for the use of the report recipient to assist in future retrieval of the document.

Block 4. Title and Subtitle. Enter the title in all capital letters exactly as it appears on the publication. Titles should be unclassified whenever possible. Write out the English equivalent for Greek letters and mathematical symbols in the title (see "Abstracting Scientific and Technical Reports of Defense-sponsored RDT/E," AD-667 000). If the report has a subtitle, this subtitle should follow the main title, be separated by a comma or semicolon if appropriate, and be initially capitalized. If a publication has a title in a foreign language, translate the title into English and follow the English translation with the title in the original language. Make every effort to simplify the title before publication.

Block 5. Type of Report and Period Covered. Indicate here whether report is interim, final, etc., and, if applicable, inclusive dates of period covered, such as the life of a contract covered in a final contractor report.

Block 6. Performing Organization Report Number. Only numbers other than the official report number shown in Block 1, such as series numbers for in-house reports or a contractor/grantee number assigned by him, will be placed in this space. If no such numbers are used, leave this space blank.

Block 7. Author(s). Include corresponding information from the report cover. Give the name(s) of the author(s) in conventional order (for example, John R. Doe or, if author prefers, J. Robert Doe). In addition, list the affiliation of an author if it differs from that of the performing organization.

Block 8. Contract or Grant Number(s). For a contractor or grantee report, enter the complete contract or grant number(s) under which the work reported was accomplished. Leave blank in in-house reports.

Block 9. Performing Organization Name and Address. For in-house reports enter the name and address, including office symbol, of the performing activity. For contractor or grantee reports enter the name and address of the contractor or grantee who prepared the report and identify the appropriate corporate division, school, laboratory, etc., of the author. List city, state, and ZIP Code.

Block 10. Program Element, Project, Task Area, and Work Unit Numbers. Enter here the number code from the applicable Department of Defense form, such as the DD Form 1498, "Research and Technology Work Unit Summary" or the DD Form 1634, "Research and Development Planning Summary," which identifies the program element, project, task area, and work unit or equivalent under which the work was authorized.

Block 11. Controlling Office Name and Address. Enter the full, official name and address, including office symbol, of the controlling office. (Equates to funding/sponsoring agency. For definition see DoD Directive 5200.20, "Distribution Statements on Technical Documents.")

Block 12. Report Date. Enter here the day, month, and year or month and year as shown on the cover.

Block 13. Number of Pages. Enter the total number of pages.

Block 14. Monitoring Agency Name and Address (if different from Controlling Office). For use when the controlling or funding office does not directly administer a project, contract, or grant, but delegates the administrative responsibility to another organization.

Blocks 15 & 15a. Security Classification of the Report: Declassification/Downgrading Schedule of the Report. Enter in 15 the highest classification of the report. If appropriate, enter in 15a the declassification/downgrading schedule of the report, using the abbreviations for declassification/downgrading schedules listed in paragraph 4-207 of DoD 5200.1-R.

Block 16. Distribution Statement of the Report. Insert here the applicable distribution statement of the report from DoD Directive 5200.20, "Distribution Statements on Technical Documents."

Block 17. Distribution Statement (of the abstract entered in Block 20, if different from the distribution statement of the report). Insert here the applicable distribution statement of the abstract from DoD Directive 5200.20, "Distribution Statements on Technical Documents."

Block 18. Supplementary Notes. Enter information not included elsewhere but useful, such as: Prepared in cooperation with . . . Translation of (or by) . . . Presented at conference of . . . To be published in . . .

Block 19. Key Words. Select terms or short phrases that identify the principal subjects covered in the report, and are sufficiently specific and precise to be used as index entries for cataloging, conforming to standard terminology. The DoD "Thesaurus of Engineering and Scientific Terms" (TEST), AD-672 000, can be helpful.

Block 20. Abstract. The abstract should be a brief (not to exceed 200 words) factual summary of the most significant information contained in the report. If possible, the abstract of a classified report should be unclassified and the abstract to an unclassified report should consist of publicly-releasable information. If the report contains a significant bibliography or literature survey, mention it here. For information on preparing abstracts see "Abstracting Scientific and Technical Reports of Defense-Sponsored RDT&E," AD-667 000.

UPPER MISSISSIPPI - KASKASKIA - ST. LOUIS BASIN

DEERWOOD LAKE NO. 3 DAM

JEFFERSON COUNTY, MISSOURI

MO 30460

**PHASE 1 INSPECTION REPORT
NATIONAL DAM SAFETY PROGRAM**



**United States Army
Corps of Engineers**

*... Serving the Army
... Serving the Nation*

St. Louis District

PREPARED BY: U.S. ARMY ENGINEER DISTRICT, ST. LOUIS

FOR: STATE OF MISSOURI

APRIL 1981

DEERWOOD LAKE NO. 3 DAM
MISSOURI INVENTORY NO. 30460
JEFFERSON COUNTY, MISSOURI

PHASE I INSPECTION REPORT
NATIONAL DAM SAFETY PROGRAM

PREPARED BY:

HORNER & SHIFRIN, INC.
5200 OAKLAND AVENUE
ST. LOUIS, MISSOURI 63110

FOR:

U. S. ARMY ENGINEER DISTRICT, ST. LOUIS
CORPS OF ENGINEERS

APRIL 1981

HS-8088

PHASE I REPORT

NATIONAL DAM SAFETY PROGRAM

Name of Dam: Deerwood Lake No. 3 Dam
State Located: Missouri
County Located: Jefferson
Stream: Tributary of Isum Creek
Date of Inspection: 7 November 1980

The Deerwood Lake No. 3 Dam, which according to the St. Louis District, Corps of Engineers, is of significant hazard potential, was visually inspected by engineering personnel of Horner & Shifrin, Inc., Consulting Engineers, St. Louis, Missouri. The purpose of this inspection was to assess the general condition of the dam with respect to safety and, based upon this inspection and available data, determine if the dam poses an appreciable danger to human life or property. Evaluation of this dam was performed in accordance with the "Phase I" investigation procedures prescribed in "Recommended Guidelines for Safety Inspection of Dams", dated May 1975.

The following summarizes the findings of the visual inspection and the results of certain hydrologic/hydraulic investigations performed under the direction of the inspection team. Based on the visual inspection, the present general condition of the dam is considered to be somewhat less than satisfactory. Several items were noticed during the inspection which are considered to have an adverse effect on the overall safety and future operation of the dam. These items include trees and areas of dense brush on the downstream face of the embankment, erosion of the grass covered upstream face of the dam, seepage, tree stumps with sprouts on the upstream face of the dam, eroded areas believed to be the remnants of animal burrows at the upstream face of the dam, dense undergrowth within the spillway approach area, and a fence across the width of the spillway.

According to the criteria set forth in the recommended guidelines, the magnitude of the spillway design flood for the Deerwood Lake No. 3 Dam, which according to Table 1 of the guidelines, is classified as small in size, is specified, according to Table 3 of the guidelines for a dam of significant hazard potential and of small size, to be a minimum of the 100-year frequency flood and can be, depending upon the degree of risk involved, as much as one-half the Probable Maximum Flood (PMF). The 1 percent chance flood is the flood magnitude expected to be exceeded, on the average, of once in 100 years. It may also be expressed as an exceedence frequency with a 1 percent chance of being exceeded in any given year. The Probable Maximum Flood (PMF) is the flood that may be expected from the most severe combination of critical meteorologic and hydrologic conditions that are reasonably possible in the region. Considering the fact that a relatively small volume of water is impounded by the dam, that the flood plain downstream of the dam is fairly broad, that there are but four dwellings within the potential flood damage zone, and that the dwellings are located well above the streambed, it is recommended that the spillway for this dam be designed for the 100-year frequency flood.

Results of a hydrologic/hydraulic analysis indicated that the spillway is adequate to pass lake outflow resulting from the 100-year frequency flood and the lake outflow corresponding to about 30 percent of the PMF lake inflow without overtopping the dam. According to the St. Louis District, Corps of Engineers, the length of the downstream flood damage zone, should failure of the dam occur, is estimated to be two miles. Accordingly, within the possible damage zone are four dwellings, Dam No. 30431, and two farm buildings. According to the Corps of Engineers, Dam No. 30431 has a significant hazard classification.

A review of available data did not disclose that seepage or stability analyses of the dam were performed. This is considered a deficiency and should be rectified.

It is recommended that the Owner take the necessary action promptly to correct or control the deficiencies and safety defects reported herein.

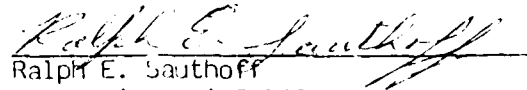
Ralph E. Sauthoff
P. E. Missouri E-19090

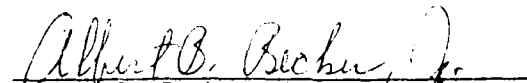
Albert B. Becker, Jr.
P. E. Missouri E-9168



OVERVIEW GEORGE WASHINGTON DAM

PHASE 1 INSPECTION REPORT

NATIONAL DAM SAFETY PROGRAM

DEERWOOD LAKE NO. 3 DAM - MO 30460

TABLE OF CONTENTS

<u>Paragraph No.</u>	<u>Title</u>	<u>Page No.</u>
SECTION 1 - PROJECT INFORMATION		
1.1	General	1-1
1.2	Description of Project	1-1
1.3	Pertinent Data	1-3
SECTION 2 - ENGINEERING DATA		
2.1	Design	2-1
2.2	Construction	2-1
2.3	Operation	2-1
2.4	Evaluation	2-1
SECTION 3 - VISUAL INSPECTION		
3.1	Findings	3-1
3.2	Evaluation	3-4
SECTION 4 - OPERATIONAL PROCEDURES		
4.1	Procedures	4-1
4.2	Maintenance of Dam	4-1
4.3	Maintenance of Outlet Operating Facilities	4-1
4.4	Description of Any Warning System in Effect	4-1
4.5	Evaluation	4-1

<u>Paragraph No.</u>	<u>Title</u>	<u>Page No.</u>
	SECTION 5 - HYDRAULIC/HYDROLOGIC	
5.1	Evaluation of Features	5-1
	SECTION 6 - STRUCTURAL STABILITY	
6.1	Evaluation of Structural Stability	6-1
	SECTION 7 - ASSESSMENT/REMEDIAL MEASURES	
7.1	Dam Assessment	7-1
7.2	Remedial Measures	7-2

LIST OF PLATES

<u>Plate No.</u>	<u>Title</u>
1	Regional Vicinity Map
2	Subdivision Plat
3	Lake Watershed Map
4	Dam Plan and Profile
5	Dam Cross-Section
6	Spillway Profile & Sections

APPENDIX A - INSPECTION PHOTOGRAPHS

<u>Page No.</u>	<u>Title</u>
A-1 thru A-3	Inspection Photographs

APPENDIX B - HYDROLOGIC AND HYDRAULIC ANALYSES

<u>Page No.</u>	<u>Title</u>
B-1 thru B-3	Hydrologic & Hydraulic Computations
B-4 thru B-6	Computer Input Data
B-7 thru B-10	Computer Output Data
B-11	Lake Surface Area, Elevation and Storage Volume; Summary of Dam Safety Analysis

PHASE I INSPECTION REPORT
NATIONAL DAM SAFETY PROGRAM
DEERWOOD LAKE NO. 3 DAM - MO 30460

SECTION 1 - PROJECT INFORMATION

1.1 GENERAL

a. Authority. The National Dam Inspection Act, Public Law 92-367, dated 8 August 1972, authorized the Secretary of the Army, through the Corps of Engineers, to initiate a program of safety inspection of dams throughout the United States. Pursuant to the above, the St. Louis District, Corps of Engineers, directed that a safety inspection of the Deerwood Lake No. 3 Dam be made.

b. Purpose of Inspection. The purpose of this visual inspection was to make an assessment of the general condition of the dam with respect to safety and, based upon available data and this inspection, determine if the dam poses an appreciable danger to human life or property.

c. Evaluation Criteria. This evaluation was performed in accordance with the "Phase I" investigation procedures as prescribed in "Recommended Guidelines for Safety Inspection of Dams", Appendix D to "Report to the Chief of Engineers on the National Program of Inspection of Non-Federal Dams", dated May 1975.

1.2 DESCRIPTION OF PROJECT

a. Description of Dam and Appurtenances. The Deerwood Lake No. 3 Dam is an earthfill type embankment rising approximately 25 feet above the natural streambed at the downstream toe of the barrier. The embankment has an upstream slope of approximately 1v on 2.2h near the crest which flattens to about 1v on 4.3h beginning at a point about 2 feet below the crest and extending to the waterline. (This somewhat flatter slope may be a result of erosion since this area of the dam is normally submerged being below the

spillway crest elevation.) The dam crest, a crowned section, is about 19 feet wide. The downstream face has an irregular slope which, at the location of the original stream channel, varies considerably but appears to be no steeper than 1v on 1.8h. The length of the dam is approximately 514 feet. A plan and profile of the dam are shown on Plate 4, a cross section of the dam is presented on Plate 5, and an overview photograph of the dam is shown following the preface at the front of the report. At normal pool elevation, the reservoir impounded by the dam occupies approximately 4.1 acres. A 2-1/2-inch diameter pipe with a valve located at the downstream end of the pipe serves as a lake drawdown facility. This outlet is located near the center of the dam, at the toe of the embankment.

The spillway, a paved concrete, rectangular section with concrete retaining walls on either side, is located at the right, or north, abutment. A 0.9-foot high wire screen fence with 1-inch by 2-inch openings is supported by a steel pipe frame which extends across the spillway crest. The spillway exit section, a rectangular section with a paved concrete invert and concrete block retaining walls, extends about 18 feet beyond the spillway crest. The spillway outlet channel, an irregular excavated earth V-section, joins the original stream channel approximately 80 feet downstream of the toe of the dam. A profile of the spillway and cross-sections of the spillway at selected locations are shown on Plate 6.

b. Location. The dam is located on an unnamed tributary of Isum Creek within the Lakes of Deerwood Subdivision. The subdivision lies about 0.4 mile west of the intersection of Dulin Creek Road and Hillsboro Road, and approximately 2 miles southeast of Cedar Hill, Missouri, as shown on the Regional Vicinity Map, Plate 1. The dam is located in the southwest one-quarter of Section 29, Township 42 North, Range 4 West, within Jefferson County. A plat of the Lakes of Deerwood Subdivision showing the various lakes and other improvements within the development, is presented on Plate 2.

c. Size Classification. The size classification based on the height of the dam and storage capacity, is categorized as small (per Table 1, Recommended Guidelines for Safety Inspection of Dams).

d. Hazard Classification. The Deerwood Lake No. 3 Dam, according to the St. Louis District, Corps of Engineers, has a significant hazard potential, meaning that if the dam should fail, there may be loss of life, damage to isolated homes, secondary highways or minor railroads, or cause interruption of use or service of relatively important public utilities. The estimated flood damage zone, should failure of the dam occur, as determined by the St. Louis District, extends two miles downstream of the dam. Within the possible flood damage zone are four dwellings which are located well above the streambed, Dam No. 30431, and two farm buildings. Dam No. 30431 is also located within the Lakes of Deerwood Subdivision, and according to the Corps of Engineers, has a significant hazard classification. Those features lying within the downstream damage zone reported by the Corps of Engineers, St. Louis District, were verified by the inspection team.

e. Ownership. The lake and dam are owned by Dewey Cook, Jr. Mr. Cook's address is Route 1, Box 572, Cedar Hill, Missouri 63016.

f. Purpose of Dam. The dam impounds water for recreational use.

g. Design and Construction History. According to the Owner, the dam was constructed in about 1960 by the Ficken Excavating and Material Company of Cedar Hill, Missouri. However, Mr. Walter Ficken, owner of the company at the time the dam was constructed, did not recall constructing the dam. Records of the design and construction of the dam were not available.

h. Normal Operational Procedure. The lake level is unregulated. Lake outflow is governed by the capacity of a paved concrete, excavated earth type spillway.

1.3 PERTINENT DATA

a. Drainage Area. Essentially, the area tributary to the lake is a residential subdivision development consisting of approximately 25 percent impervious area. The watershed above the dam amounts to approximately 16 acres. The watershed area is outlined on Plate 3.

b. Discharge at Damsite.

- (1) Estimated known maximum flood at damsite ... 2 cfs* (W.S.Elev. 620.2)
- (2) Spillway capacity ... 39 cfs. (W.S.Elev. 621.2)

c. Elevation (Ft. above MSL). Unless otherwise indicated, the following elevations were determined by survey and are based on topographic data shown on the 1954 Belew Creek, Missouri, Quadrangle Map, 7.5 Minute Series (photo-revised 1968 and 1974).

- (1) Observed pool ... 617.1
- (2) Normal pool ... 620.0
- (3) Spillway crest ... 620.0
- (4) Maximum experienced pool ... 620.2*
- (5) Top of dam ... 621.2 (min.)
- (6) Streambed at centerline of dam ... 597₊ (est.)
- (7) Maximum tailwater ... Unknown
- (8) Observed tailwater ... None

d. Reservoir.

- (1) Length at normal pool (Elev. 620.0) ... 600 ft.
- (2) Length at maximum pool (Elev. 621.2) ... 625 ft.

e. Storage.

- (1) Normal pool ... 30 ac. ft.
- (2) Top of dam (incremental) ... 5 ac. ft.

f. Reservoir Surface.

- (1) Normal pool ... 4.1 acres
- (2) Top of dam (incremental) ... 0.3 acre

*Based on an estimate of depth of flow at spillway as observed by the Owner.

g. Dam. The height of the dam is defined to be the overall vertical distance from the lowest point of foundation surface at the downstream toe of the barrier, to the top of the dam.

- (1) Type ... Earthfill, homogeneous*
- (2) Length ... 514 ft.
- (3) Height ... 25 ft.
- (4) Top width ... 19 ft.
- (5) Side slopes
 - a. Upstream ... Varies, 1v on 2.2h to 1v on 4.3h (above waterline)
 - b. Downstream ... Irregular 1v on 1.8h (max.)
- (6) Cutoff ... Core trench*
- (7) Slope protection
 - a. Upstream ... Grass
 - b. Downstream ... Grass

h. Spillway.

- (1) Type ... Uncontrolled, paved concrete, excavated earth rectangular section
- (2) Location ... Right abutment
- (3) Crest ... Elevation 620.0
- (4) Width ... 15 ft.
- (5) Side slopes ... Vertical
- (6) Approach channel ... Lake
- (7) Outlet channel ... Excavated earth, V-section

i. Emergency Spillway ... None

j. Lake Drawdown Facility.

- (1) Type ... Steel pipe, 2.5-inch diameter
- (2) Control ... Valve at downstream end of pipe
- (3) Outlet ... Toe of dam, elevation 596.7

*Per Owner.

SECTION 2 - ENGINEERING DATA

2.1 DESIGN

Data relating to the design of the dam were unavailable.

2.2 CONSTRUCTION

As previously stated, the Owner indicated that the dam was constructed about 1960 by the Ficken Excavating and Material Company. According to the Owner, a core trench for seepage cutoff about 8-to-10 feet wide was excavated to non-porous rock along the centerline of the dam. The Owner reported that the trench was backfilled with clay selected from the site and that some of the clay backfill was mixed with Volclay (bentonite). The Owner also recalled that the material used to construct the dam was clay obtained from the area to be occupied by the lake, and that the material was compacted using a sheepsfoot roller. No records of the construction of the dam were available.

2.3 OPERATION

The lake level is uncontrolled and governed by the elevation of the crest of the paved concrete spillway structure. No indication was found that the dam has been overtopped. The Owner reported that the dam has never been overtopped and that the highest lake level experienced to date produced a depth of flow at the spillway estimated to be about 2 inches.

2.4 EVALUATION

a. Availability. Engineering data for assessing the design of the dam and spillway were unavailable.

b. Adequacy. No data available. Seepage and stability analyses comparable to the requirements of the "Recommended Guidelines for Safety Inspection of Dams" were not available, which is considered a deficiency. These seepage and stability analyses should be performed for appropriate loading conditions (including earthquake loads) and made a matter of record.

SECTION 3 - VISUAL INSPECTION

3.1 FINDINGS

a. General. A visual inspection of the Deerwood Lake No. 3 Dam was made by Horner & Shifrin engineering personnel, R. E. Sauthoff, Civil Engineer, H. B. Lockett, Hydrologist, and A. B. Becker, Jr., Civil and Soils Engineer, on 7 November 1980. An examination of the dam area was also made by an engineering geologist, Jerry D. Higgins, Ph.D., a consultant retained by Horner & Shifrin for the purpose of assessing the site geology. Also examined at the time of the inspection, were the areas and features below the dam within the potential flood damage zone. Photographs of the dam taken at the time of the inspection are included on pages A-1 through A-3 of Appendix A. The locations of the photographs taken during the inspection are indicated on Plate 4.

b. Site Geology. Deerwood Lake No. 3 Dam is located on an unnamed tributary to Isum Creek, which flows into the Big River approximately two miles to the west. The topography in this area is moderately to gently rolling, and there is about 75 feet of relief between the reservoir and the surrounding drainage divide. The topography becomes more rugged toward the Big River Valley, so that regionally, there is about 350 feet of relief. The area is included within the northeastern part of the Ozark Plateaus Physiographic Province, and regionally, the bedrock structure dips northeastward into the Illinois Basin.

There are no rock outcrops in the immediate vicinity of the site; however, the reservoir and surrounding uplands are underlain by the Ordovician-age Jefferson City-Cotter formation. This is a light brown to gray, finely crystalline, argillaceous dolomite. It is generally thin- to medium-bedded and contains both nodular and bedded chert as well as some thin sandstone layers. Solution enlargement of joints and bedding planes is common, and the contact between bedrock and the overlying soils is generally very irregular as a result of the solution weathering. These solution features are commonly the cause of reservoir leakage when the soil cover is thin.

The soils derived from the Jefferson City formation are reddish-brown to buff-colored, moderately plastic clays, usually mixed with silt on the upland areas (ML-CL, Unified Soil Classification System). In the vicinity of the reservoir, the soils include a noticeable sand component that has probably been derived from the original overlying St. Peter Sandstone formation, that now has been totally removed from the area by erosion. Weathering of thin sandstone lenses within the formation also may have added sand to the clay soils.

No geologic conditions were noted at the site that would be considered to be detrimental to the performance of the reservoir or embankment stability.

c. Dam. The visible portions of the upstream and downstream faces of the dam (see Photos 1, 2 and 3) as well as the dam crest were inspected and except for some minor erosion of the upstream face at the normal waterline, appeared to be in sound condition. No undue settlement of the crest, sliding or sloughing of the slopes, or misalignment of the dam were noted. However, the entire downstream face of the dam could not be thoroughly examined due to the presence of dense brush and numerous trees up to about 10 inches in diameter on the slope. Except for a grass cover, the upstream face of the dam was unprotected, and erosion (see Photo 7), apparently by wave action or by fluctuations of the lake level, had created a near vertical bank up to about 12 inches high at the normal waterline. Several localized areas of erosion of the upstream face which appeared to be the remnants of abandoned animal burrows, were observed. Two tree stumps with numerous willow sprouts were also present on the upstream face of the dam. The crest of the dam was covered with 4-inch high grass (fescue) and lespedesa. Examination of a soil sample obtained from the downstream face of the dam at about the center of the structure indicated the material to be a brown, silty-lean clay (CL) of low-to-medium plasticity.

Seepage (see Photo 8) as evidenced by cattails, wet ground, and standing and flowing water (see Photo 9), was observed along the original stream channel near the toe of the dam in an area approximately 20 feet wide and 40 feet long. The flow of water from the area, believed to be lake seepage, was estimated to be about one gallon per minute. The lake drawdown valve (see

Photo 6) was not operated at the time of inspection, but appeared to be in satisfactory condition with no signs of seepage about the pipe.

The concrete spillway structure (see Photo 4) was also inspected and, except as noted herein, appeared to be in reasonably good condition. Several minor cracks were noted in the concrete invert pavement of the crest section, and a 0.9 foot high wire mesh fence with 1-inch by 2-inch openings supported by a steel pipe frame was observed across the spillway at the crest location. The concrete block type retaining walls of the exit section (see Photo 5) were slightly displaced and somewhat misaligned, and the concrete invert pavement of the exit section was cracked at numerous locations. The spillway exit section, the area adjacent to the exit section, and the outlet channel just downstream of the section, were overgrown with dense brush and small trees.

d. Appurtenant Structures. No appurtenant structures were observed at this dam site.

e. Downstream Channel. Except for a 12-inch pipe culvert at Hillandale Drive, a road within the Lakes of Deerwood Subdivision, the downstream channel within the designated flood damage zone is unimproved. However, at a point approximately 230 feet downstream of the dam, the channel joins Deerwood Lake No. 1. The Dam for Deerwood Lake No. 1, which has a surface area of about 7 acres, lies approximately 1,000 feet downstream of the Deerwood Lake No. 3 Dam.

f. Reservoir. At the time of inspection, the reservoir was approximately 2.9 feet below normal level and the lake water was clear. No significant erosion of the lake banks was evident. The area about the lake is a residential development and well maintained with established lawns. However, the reservoir area just upstream of the spillway was noticeably overgrown with weeds and brush. The amount of sediment within the lake could not be determined during the inspection; however, due to the turf cover on the area surrounding the lake, it is not expected to be significant.

3.2 EVALUATION

The deficiencies observed during the inspection and noted herein, are not considered of significant importance to warrant immediate remedial action, but should be rectified without undue delay.

SECTION 4 - OPERATIONAL PROCEDURES

4.1 PROCEDURES

The spillway is uncontrolled. The lake surface level is governed by precipitation runoff, evaporation, seepage, and the capacity of the uncontrolled spillway.

4.2 MAINTENANCE OF DAM

According to the Owner, the dam receives periodic routine maintenance such as mowing of the grass on the dam crest and yearly removal by trapping of muskrats.

4.3 MAINTENANCE OF OUTLET OPERATING FACILITIES

With the exception of the lake drawdown pipe, no outlet facilities requiring operation exist at this dam, and there is no reservoir regulation plan.

4.4 DESCRIPTION OF ANY WARNING SYSTEMS IN EFFECT

The Owner who resides adjacent to the lake reported that telephone numbers of the local police and fire departments were readily available in the case of an emergency, such as the imminent failure of the dam. The inspection did not reveal the existence of any other type of dam failure warning system.

4.5 EVALUATION

It is recommended that maintenance of the dam also include removal of trees and periodic cutting of grass on the slopes as well as the removal of undergrowth from the area just upstream of the spillway outlet. Measures should also be taken to prevent further erosion of the upstream face of the dam at the normal waterline. It is also recommended that a detailed inspection of the dam be instituted on a regular basis by an engineer experienced in the design and construction of dams and that records be kept of all inspections made and remedial measures taken.

SECTION 5 - HYDRAULIC/HYDROLOGIC

5.1 EVALUATION OF FEATURES

a. Design Data. Design data were not available.

b. Experience Data. The drainage area and lake surface area were determined from topographic data shown on the 1954 USGS Belew Creek, Missouri, Quadrangle Map (photorevised 1968 and 1974). The proportions and dimensions of the spillway and dam were developed from surveys made during the inspection. Records of rainfall, streamflow, or flood data for the watershed were not available.

Due to the fact that the watershed for this reservoir is small and since there is no history of excessive reservoir leakage that would adversely affect the normal operating level of the lake, the lake level was assumed to be at normal pool as a result of antecedent storms prior to occurrence of the PMF and the probabilistic storm.

According to the St. Louis District, Corps of Engineers, the estimated flood damage zone, should failure of the dam occur, extends two miles downstream of the dam.

c. Visual Observations.

(1) The spillway, a concrete paved rectangular section with concrete retaining walls on both sides, is located at the right, or north, abutment. A 0.9-foot high welded wire fence with 1-inch by 2-inch mesh, is supported by a steel pipe frame extending across the width of the spillway at the crest section. The spillway exit channel section, extending from the spillway crest section to the intersection with the toe of the embankment, about 18 feet downstream of the crest, is a rectangular section with a concrete paved invert and concrete block side walls, one course high.

(2) The spillway outlet channel, an irregular excavated earth V-section, joins the original stream channel some 80 feet downstream of the toe of the dam.

(3) Spillway releases within the capacity of the spillway section should not endanger the dam.

(4) A 2.5-inch steel pipe with the valve located at the outlet end is provided for lake drawdown. The valve is located at the downstream toe of the dam near the center of the structure.

d. Overtopping Potential. The spillway is inadequate to pass the probable maximum flood, or 1/2 of the probable maximum flood, without overtopping the dam. The spillway is adequate, however, to pass the 1 percent probability (100-year frequency) flood without overtopping the dam. The results of the dam overtopping analyses are as follows:

(Note: The data appearing in the following table were extracted from the computer output data appearing in Appendix B. Decimal values have been rounded to the nearest one-tenth in order to prevent assumption of unwarranted accuracy.)

<u>Ratio of PMF</u>	<u>Q-Peak Outflow (cfs)</u>	<u>Max. Lake W.S. Elev.</u>	<u>Max. Depth (Ft.) of Flow over Dam (Elev. 621.2)</u>	<u>Duration of Overtopping of Dam (Hours)</u>
0.50	162	621.5	0.3	0.9
1.00	376	621.6	0.4	5.0
1% Prob. Flood	20	620.9	0.0	0.0

The lowest point in the dam crest was found to be elevation 621.2. The flow safely passing the spillway just prior to overtopping was determined to be approximately 39 cfs, which is the routed outflow corresponding to about 30 percent of the probable maximum flood inflow. During peak flow of the probable maximum flood, the greatest depth of flow over the dam is projected to be 0.4 foot and overtopping is estimated to extend across the central 490 feet of the dam.

e. Evaluation. The results of the overtopping analyses indicate the existing spillway is adequate to pass the 1 percent chance (100-year frequency) flood, which is the recommended spillway design flood for this dam, without overtopping the dam. This does not mean that floods greater than the recommended spillway design flood will not occur, or that overtopping of the dam as a result of these floods will not take place. With regard to floods greater than the recommended spillway design, the following evaluation of dam overtopping by the PMF and the one-half PMF events is offered:

Experience with embankments constructed of similar material (a silty lean clay of low-to-medium plasticity) to that used to construct this dam has shown evidence that under certain conditions, such as high velocity flow, i.e., a flow velocity greater than 5 feet per second, the material can be very erodible. Although, for the PMF condition, the depth of flow over the dam crest, a maximum of 0.4 foot, is relatively small, the duration of flow over the dam, 5.0 hours, is substantial, and due to the erosive nature of this soil, damage to the crest and downstream face of the dam is expected during overtopping. The extent of these damages is not predictable within the scope of these investigations; however, there is a possibility that they could result in failure by erosion of the dam. For the one-half PMF condition and due primarily to the fact that the duration of overtopping is projected to be only 0.9 of an hour, no serious damage, such as failure of the dam, is expected as a result of overtopping.

f. References. Procedures and data for determining the probable maximum flood, the 1 percent probability (100-year frequency) flood and the discharge rating curve for flow passing the spillway are presented on pages B-1 through B-3 of the Appendix. Listings of the HEC-1 (Dam Safety Version) input data for both the probable maximum flood and the 1 percent probability (100-year frequency) flood are shown on pages B-4 through B-6. Computer output data, including unit hydrograph ordinates, tabulation of PMF rainfall, loss and inflow data are shown on pages B-7 through B-10; tabulation of lake surface area, elevation and storage volume is shown on page B-11 and tabulations titled "Summary of Dam Safety Analysis" for the PMF and 1 percent probability (100-year frequency) flood are also shown on page B-11.

SECTION 6 - STRUCTURAL STABILITY

6.1 EVALUATION OF STRUCTURAL STABILITY

a. Visual Observations. Visual observations of conditions which adversely affect the structural stability of the dam are discussed in Section 3, paragraph 3.1c.

b. Design and Construction Data. No design or construction data relating to the structural stability of the dam are known to exist. Seepage and stability analyses comparable to the requirements of the "Recommended Guidelines for Safety Inspection of Dams" were not available, which is considered a deficiency. These seepage and stability analyses should be performed for appropriate loading conditions (including earthquake loads) and made a matter of record.

c. Operating Records. With the exception of the valve on the lake drawdown pipe, no appurtenant structures or facilities requiring operation exist at this dam. According to the Owner, no records are kept of the lake level, spillway discharge, dam settlement, or seepage.

d. Post Construction Changes. According to the Owner, no post construction changes have been made or have occurred which would affect the structural stability of the dam.

e. Seismic Stability. The dam is located within a Zone II seismic probability area. An earthquake of the magnitude that might occur in this area would not be expected to cause structural damage to a well constructed earth dam of this size provided that static stability conditions are satisfactory and conventional safety margins exist. However, it is recommended that the prescribed seismic loading for this zone be applied in any stability analyses performed for this dam.

SECTION 7 - ASSESSMENT/REMEDIAL MEASURES

7.1 DAM ASSESSMENT

a. Safety. A hydraulic analysis indicated that the spillway is capable of passing lake outflow of about 29 cfs without the level of the lake exceeding the low point in the top of the dam. A hydrologic analysis of the lake watershed area, as discussed in Section 5, paragraph 5.1d, indicates that for storm runoff resulting from the 1 percent chance (100-year frequency) flood (the recommended spillway design flood for this dam), the lake outflow would be about 20 cfs. Since the capacity of the existing spillway exceeds the recommended spillway design flood, the proportions of the spillway are considered adequate and no revisions are believed necessary. However, this does not imply that floods greater than the recommended spillway design flood will not occur, or that overtopping of the dam as a result of these floods will not take place.

Seepage and stability analyses of the dam were not available for review, and therefore, no judgment could be made with respect to the structural stability of the dam.

Several items were noticed during the inspection that could adversely affect the safety of the dam. These items include trees and brush on the downstream slope of the embankment, the lack of adequate slope protection to prevent erosion of the upstream face of the dam, seepage, tree stumps with sprouts on the upstream face of the dam, eroded areas believed to be the remnants of animal burrows at the upstream face of the dam, dense undergrowth just upstream of the spillway, and a fence across the width of the spillway.

b. Adequacy of Information. Due to lack of design and construction data, the dam assessments reported herein were based on external conditions as determined during the visual inspection. The assessments of the hydrology of the watershed and capacity of the spillway were based on a hydrologic/hydraulic study as indicated in Section 5. Seepage and stability analyses comparable to the requirements of "Recommended Guidelines for Safety Inspection of Dams" were not available, which is considered a deficiency.

c. Urgency. The remedial measures recommended in paragraph 7.2 for the items concerning the safety of the dam noted in paragraph 7.1a should be accomplished promptly.

d. Necessity for Phase II. Based on the results of the Phase I inspection, a Phase II investigation is not recommended.

e. Seismic Stability. The dam is located within a Zone II seismic probability area. An earthquake of the magnitude that might occur in this area would not be expected to cause structural damage to a well constructed earth dam of this size provided that static stability conditions are satisfactory and conventional safety margins exist. However, it is recommended that the prescribed seismic loading for this zone be applied in any stability analyses performed for this dam.

7.2 REMEDIAL MEASURES

a. Recommendations. The following action is recommended.

(1) Obtain the necessary soil data and perform dam seepage and stability analyses in order to determine the structural stability of the dam for all operational conditions. Seepage and stability analyses should be performed by a qualified professional engineer experienced in the design and construction of earthen dams.

b. Operations and Maintenance (O & M) Procedures. The following O & M Procedures are recommended:

(1) Remove the trees and brush that may conceal animal burrows from the dam. Larger trees should be removed under the guidance of an engineer experienced in the design and construction of earthen dams, since indiscriminate clearing could jeopardize the safety of the dam. All holes should be filled with compacted impervious material (clay) and the existing turf cover should be restored if destroyed or missing. Maintain the turf cover at a height that will not hinder inspection of the embankment or provide cover for burrowing animals. Holes from tree roots and voids created by

burrowing animals can provide pathways for lake seepage that could lead to a piping condition (progressive internal erosion) and potential failure of the dam.

(2) Restore the areas of the upstream face of the dam that have been damaged by burrowing animals and/or erosion. Provide some form of protection other than grass for the upstream face of the dam at and above the normal waterline in order to prevent erosion. A grass covered slope is not considered adequate protection to prevent erosion by wave action or by a fluctuating lake level.

(3) Provide some means of controlling seepage evident in the area near the downstream toe of the dam. Uncontrolled seepage can lead to a piping condition which could result in failure of the dam. Drainage of the area affected by seepage should be one of the objectives of the seepage control measures since saturation of the soil weakens the foundation which could impair the stability of the dam.

(4) Remove the fence across the spillway opening and the dense undergrowth from the reservoir area just upstream of the spillway. Lake carried debris can lodge upon the fence resulting in a reduction of spillway capacity and the possibility of overtopping by lake surcharge. The undergrowth in the area just upstream of the spillway can impede flow to the outlet which could also result in overtopping.

(5) Provide maintenance of all areas of the dam and spillway on a regularly scheduled basis in order to insure features are in satisfactory operational condition.

(6) A detailed inspection of the dam should be instituted on a regular basis by an engineer experienced in the design and construction of dams. It is also recommended, for future reference, that records be kept of all inspections made and remedial measures taken.

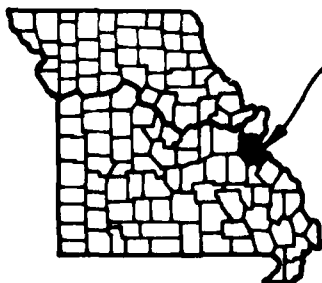
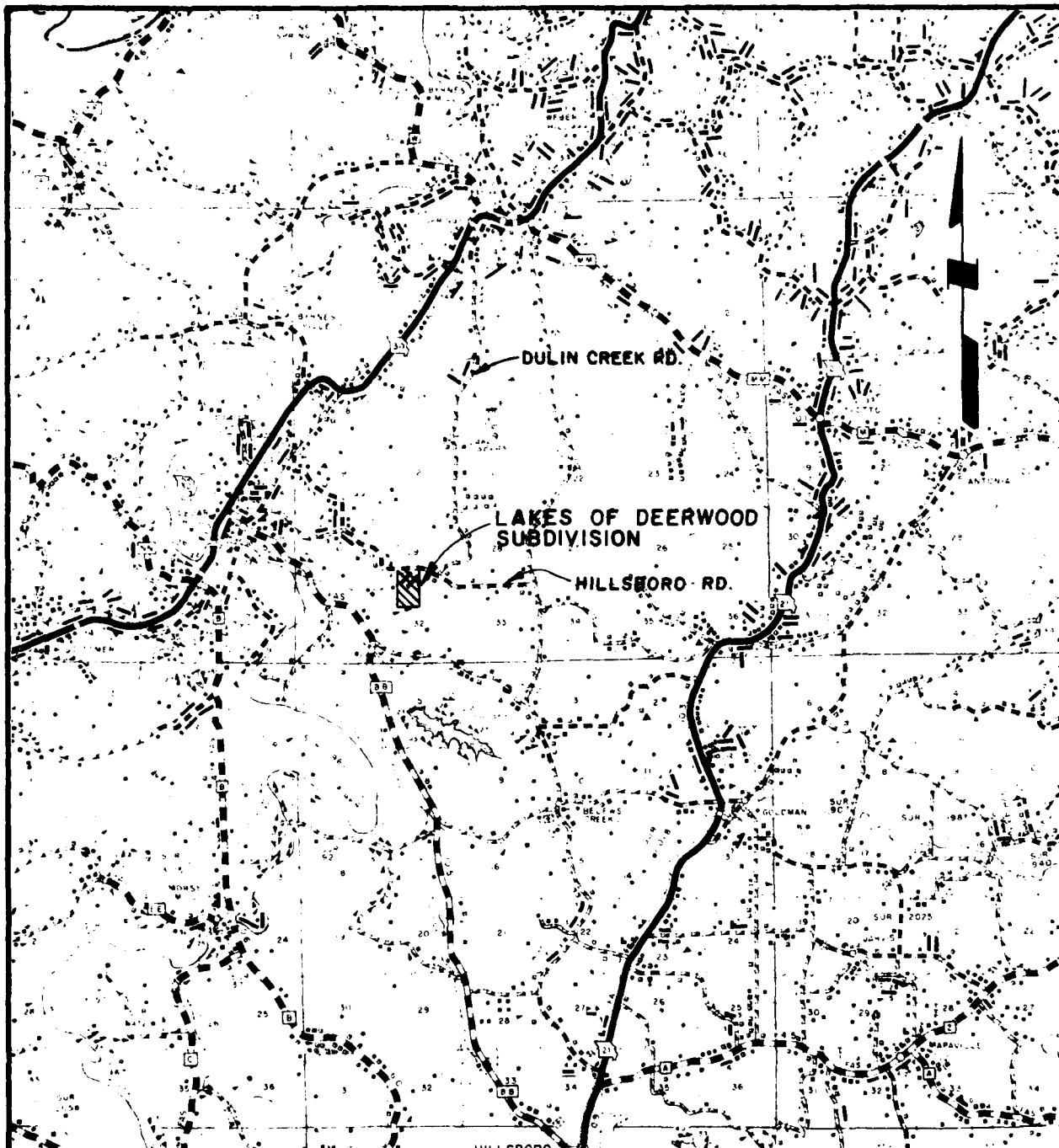

JEFFERSON COUNTY

LOCATION MAP

LAKEs OF DEERWOOD SUBDIVISION



SCALE (MILES)

REGIONAL VICINITY MAP

SECOND REVISED PLAT LAKES OF DEERWOOD

IN SECTIONS 29 & 32 - TWP. 42 N.-R. 4 E. - JEFFERSON COUNTY, MISSOURI

SCALE IN FEET
0 20 40

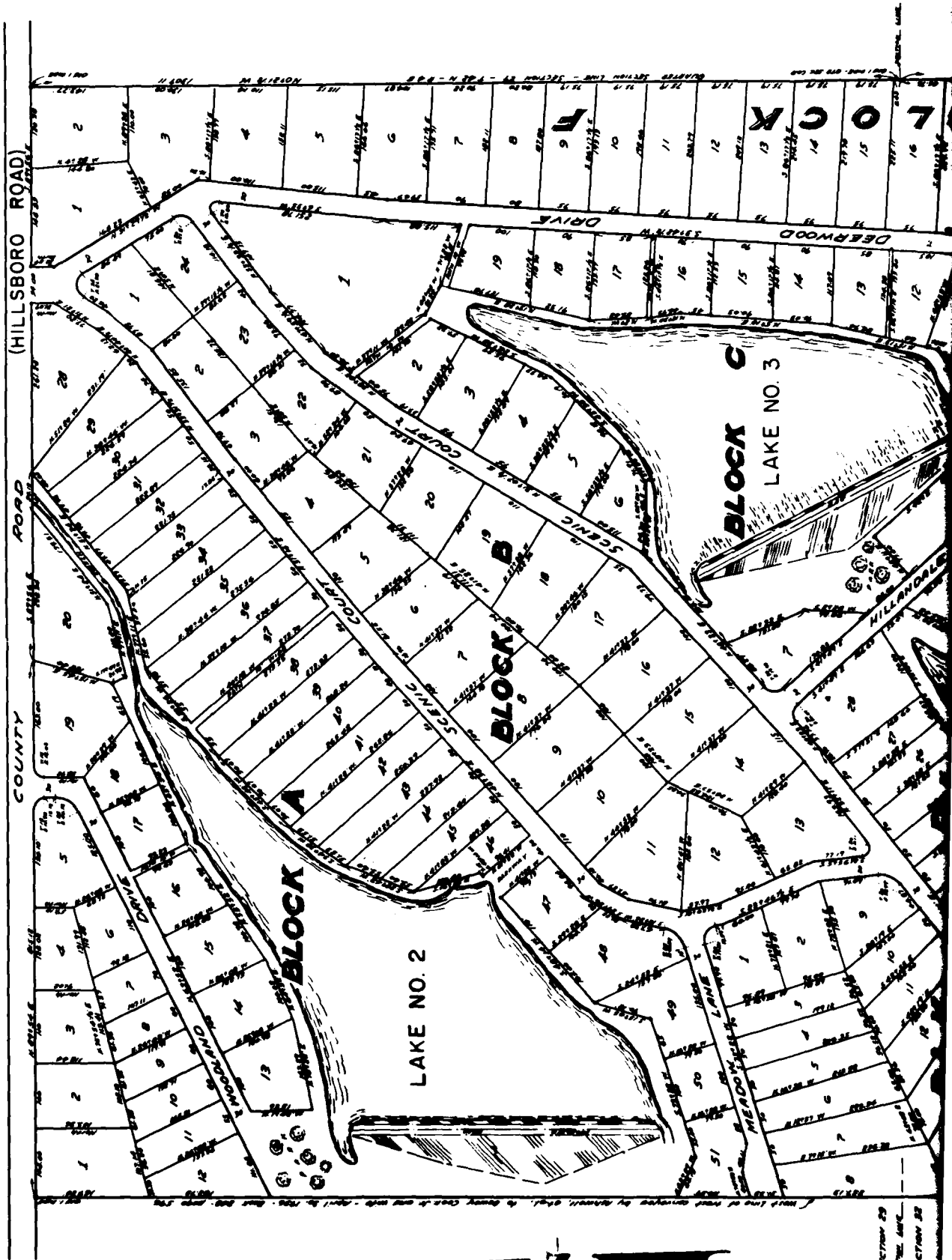

SECTION 29
SECTION 32

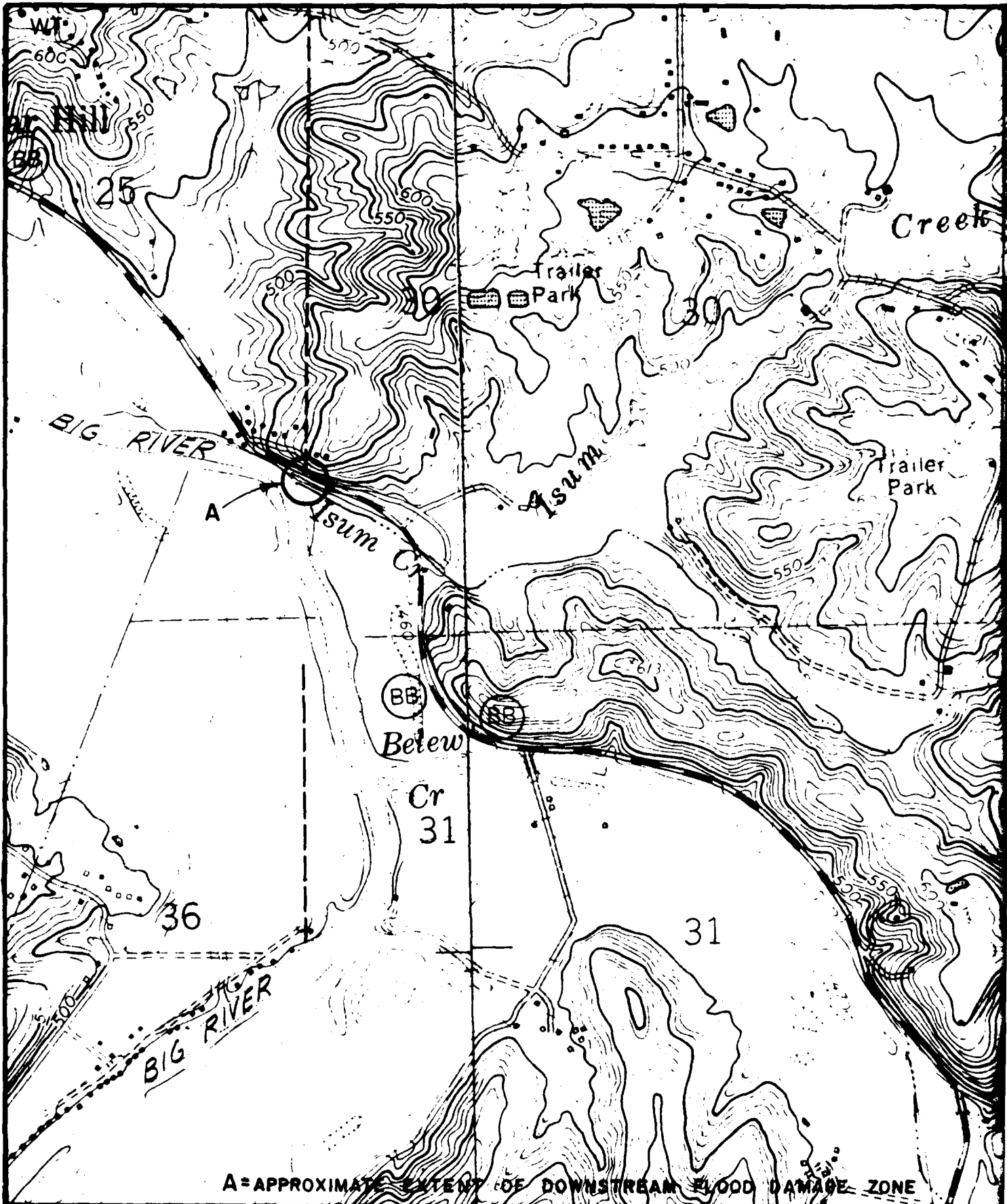

A=APPROXIMATE EXTENT OF DOWNSTREAM FLOOD DAMAGE ZONE

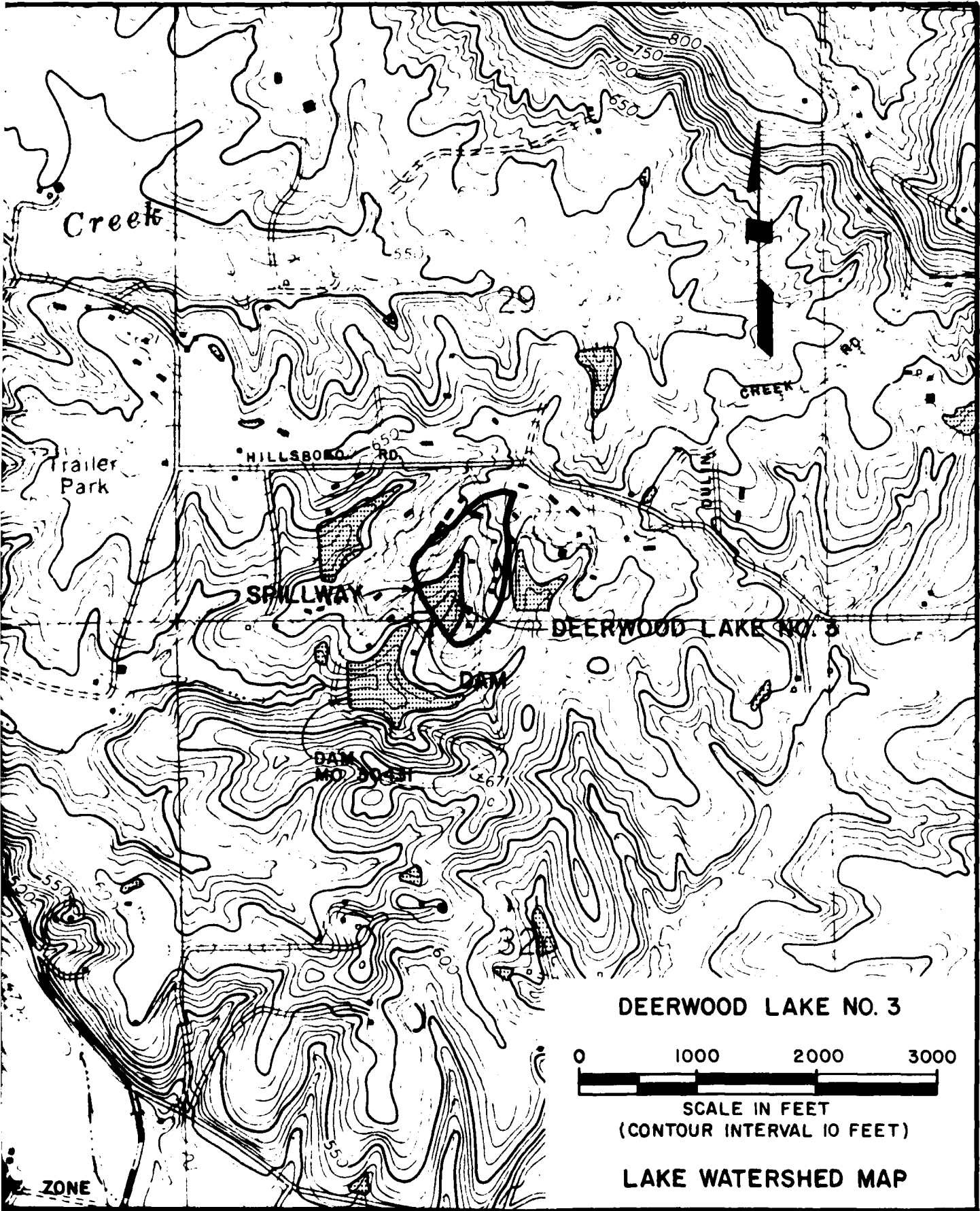

DEERWOOD LAKE NO. 3

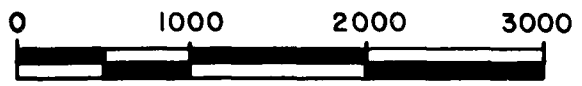

SCALE IN FEET
(CONTOUR INTERVAL 10 FEET)

LAKE WATERSHED MAP

ZONE

12

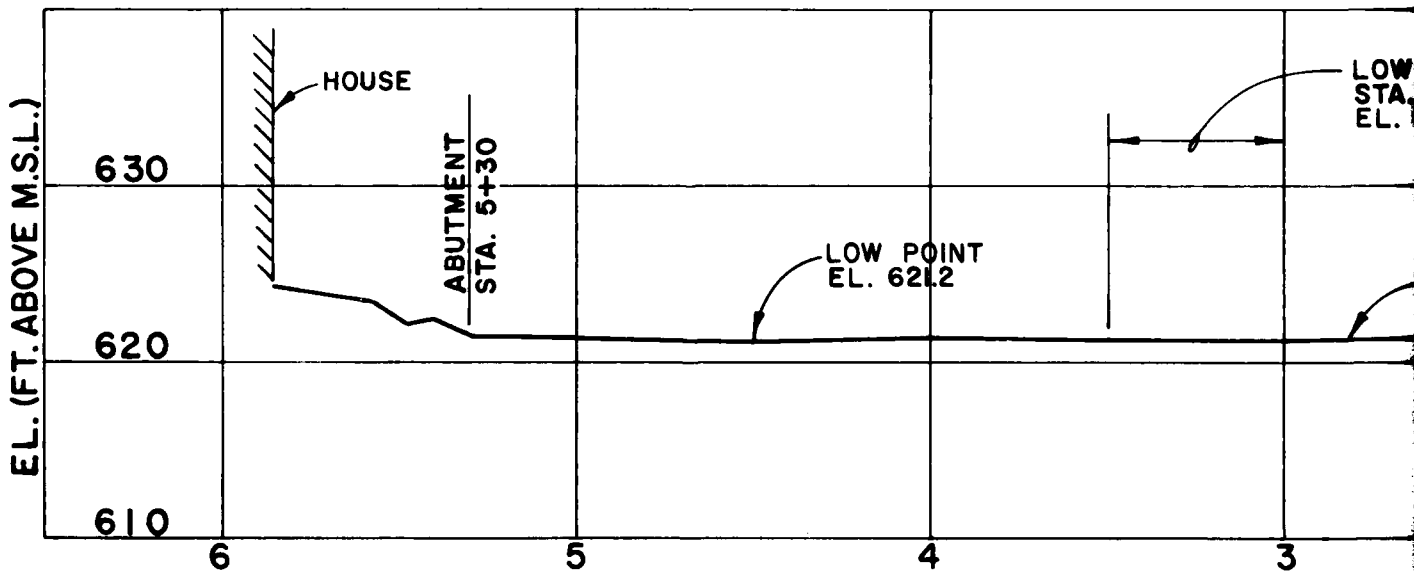
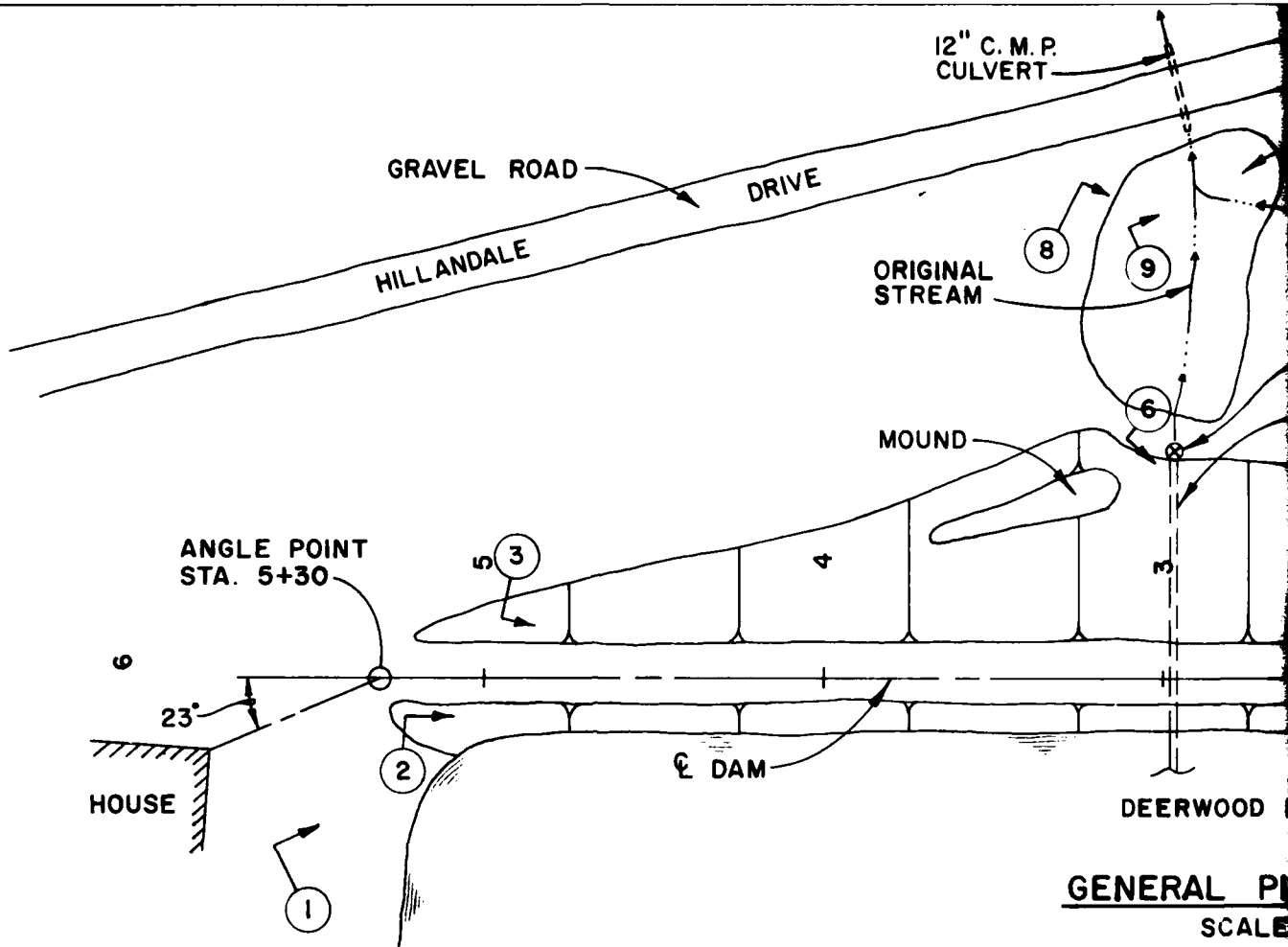

6

PHOTO LOCATION & KEY
(SEE APPENDIX A)

PROFILE
SCALE: 1" = 10'

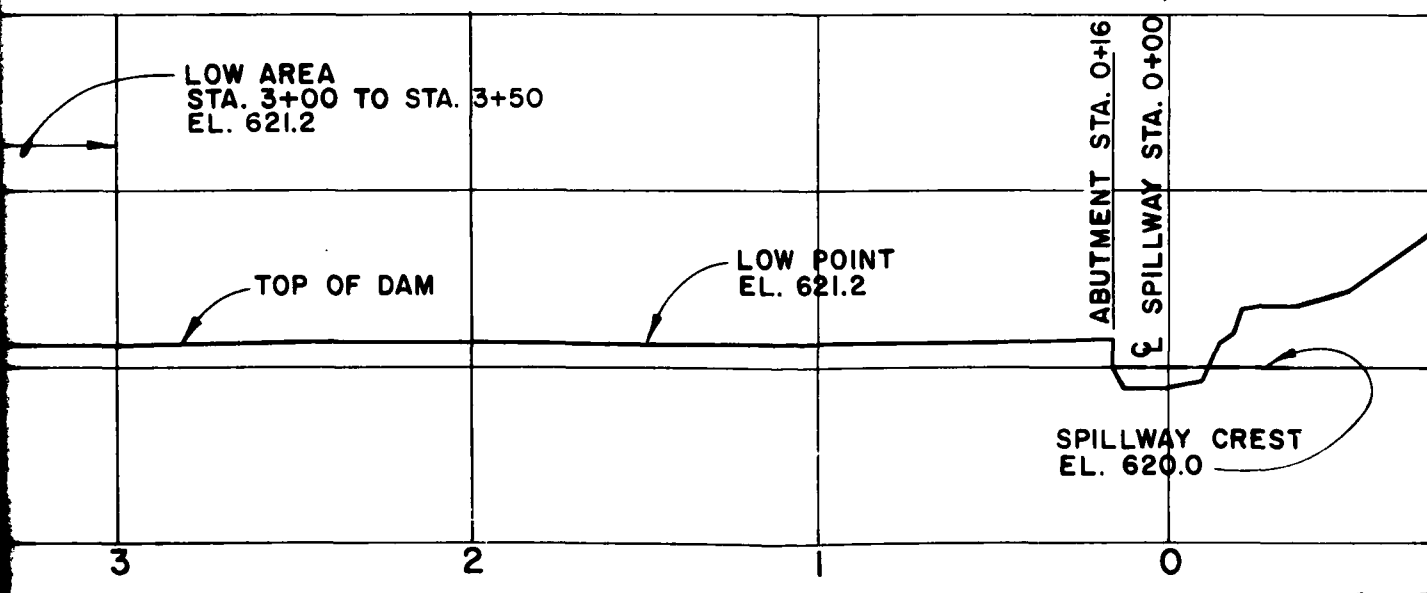
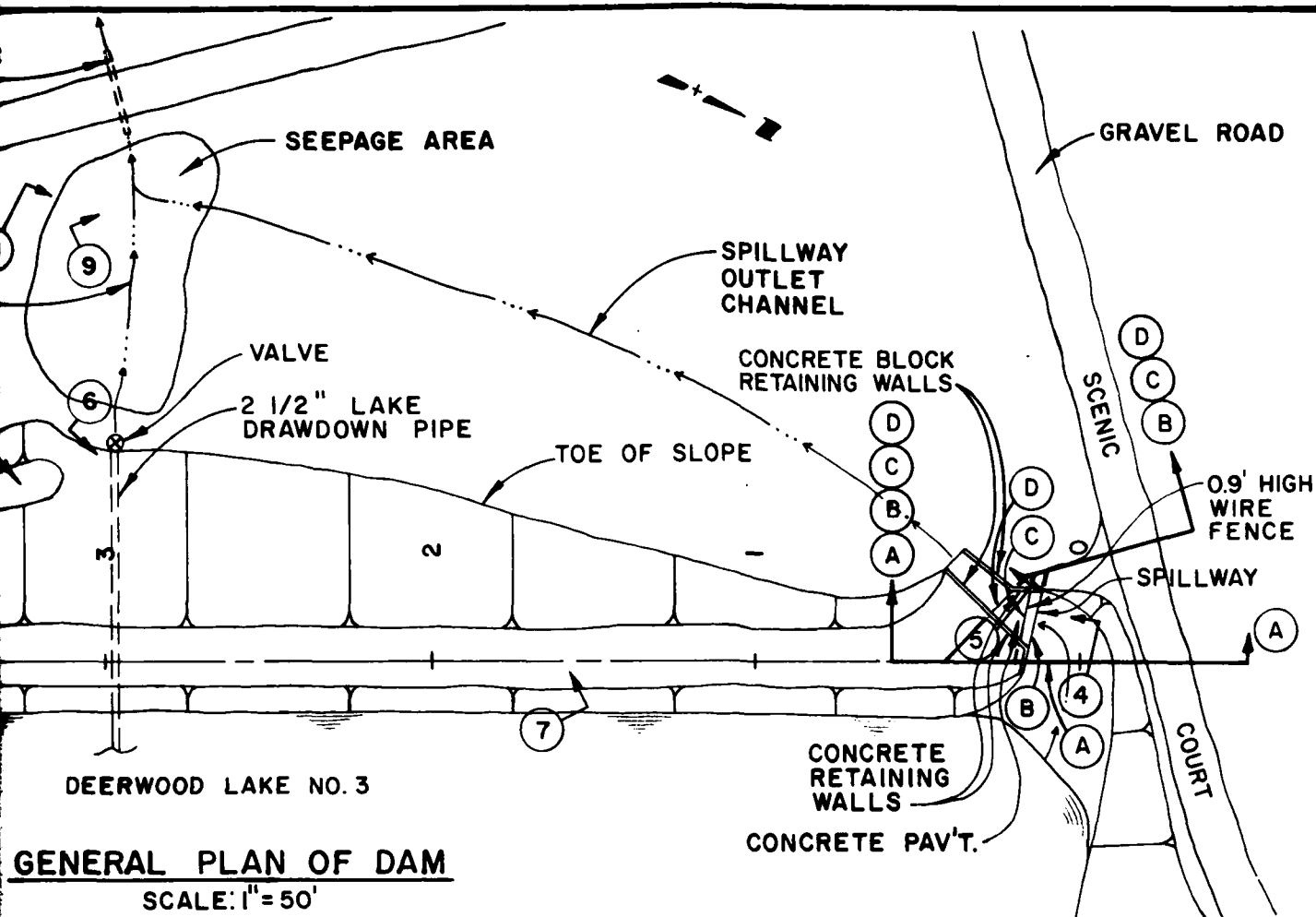

**DEERWOOD LAKE NO. 3
DAM PLAN & PROFILE**

Horner & Shifrin, Inc. Dec. 1980

2

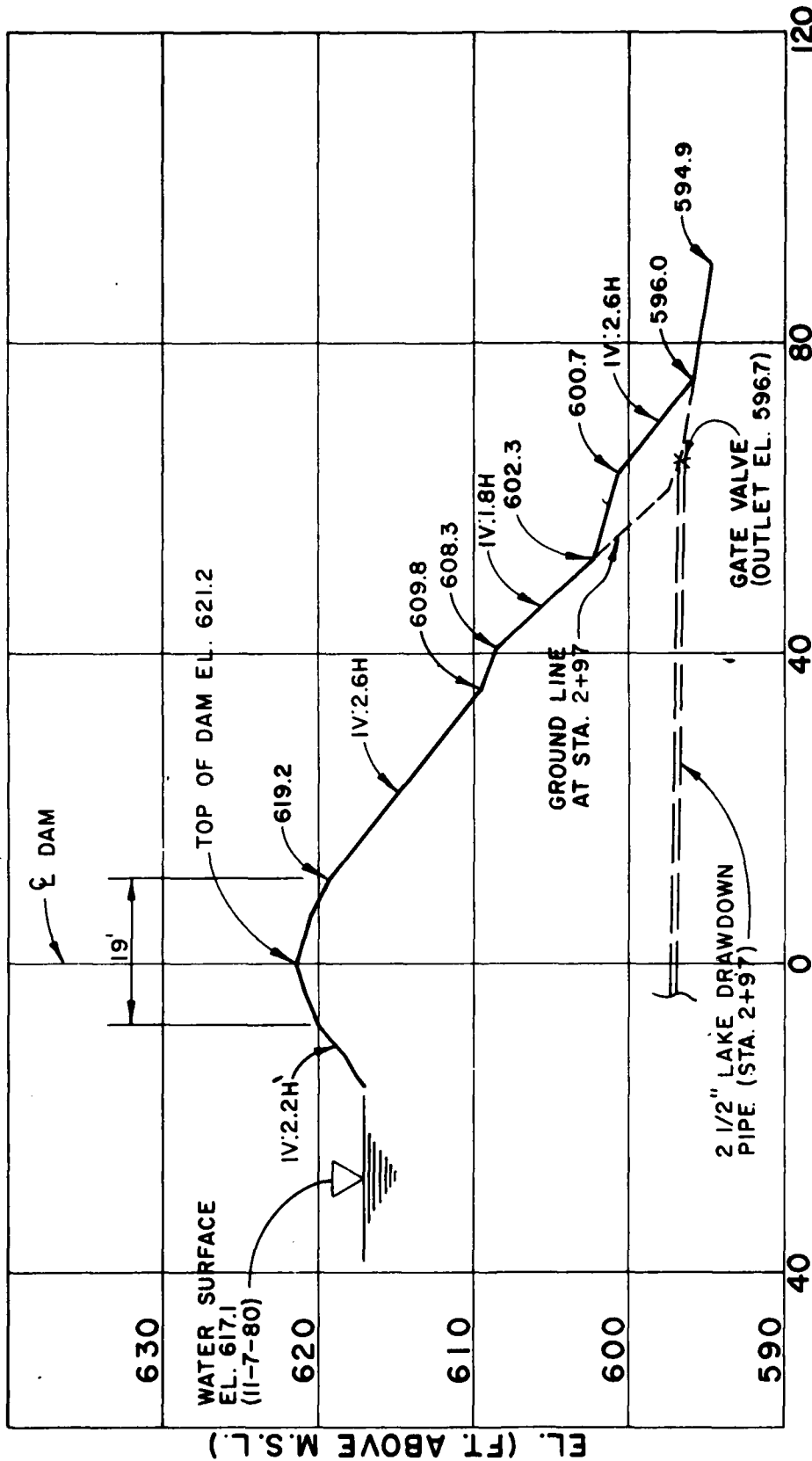

DAM CROSS-SECTION STA. 3+20

SCALE: 1" = 10' V., 1" = 20' H.

DEERWOOD LAKE NO. 3
DAM CROSS-SECTION

Horner & Shifrin, Inc.

Dec. 1980

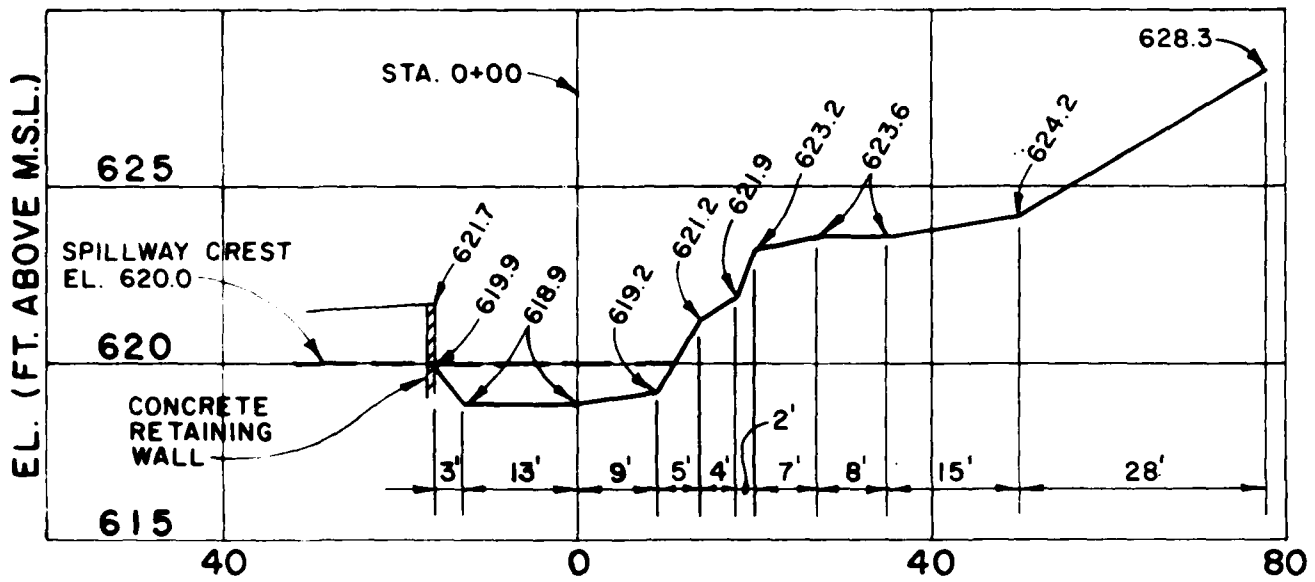

SECTION (A) - SPILLWAY CROSS-SECTION - CL DAM

SCALE: 1" = 5' V., 1" = 20' H.

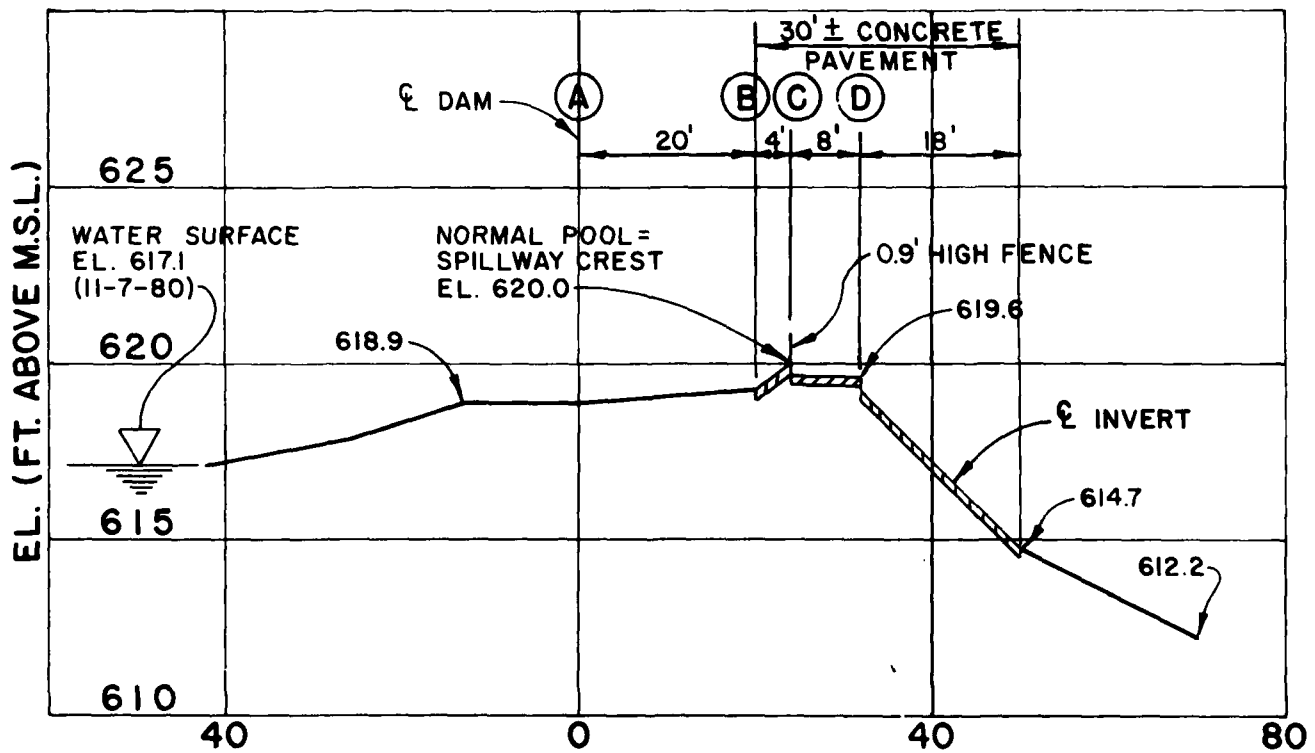

SPILLWAY PROFILE

SCALE: 1" = 5' V., 1" = 20' H.



80

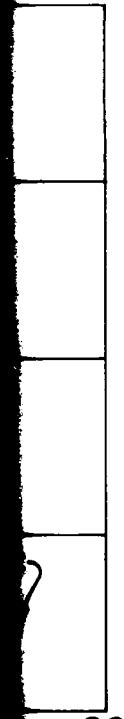

80

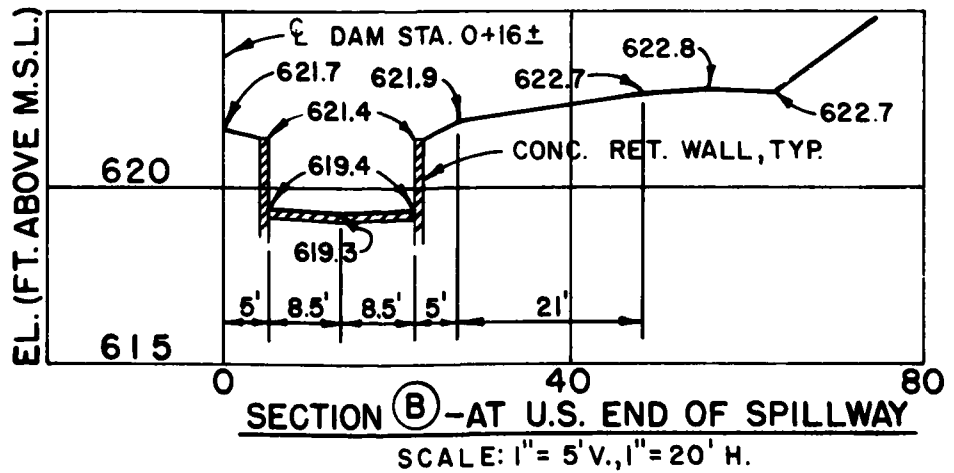
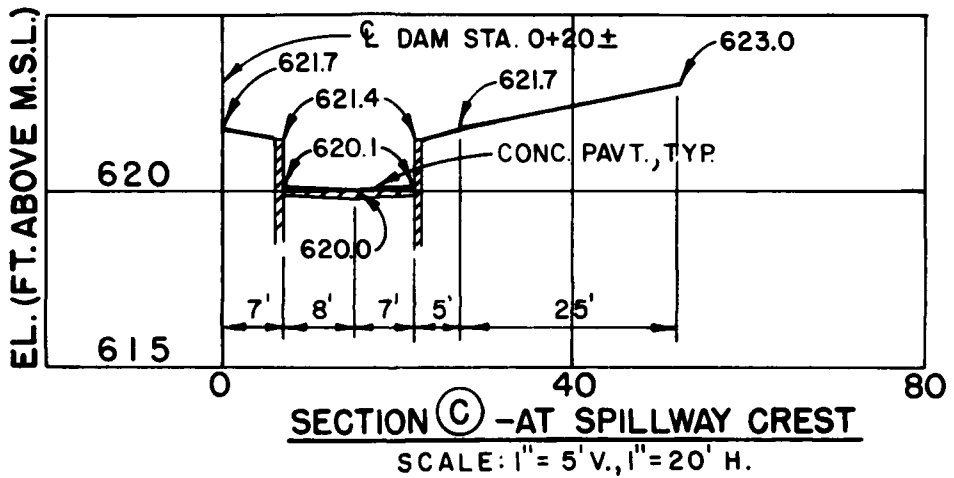
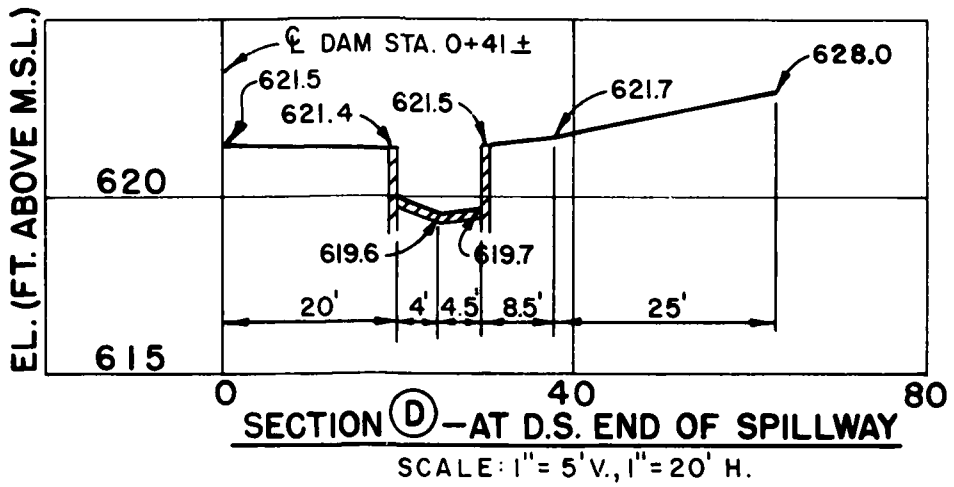

**DEERWOOD LAKE NO. 3
SPILLWAY PROFILE & SECTIONS**

Horner & Shifrin, Inc.

Dec. 1980

12

APPENDIX A

INSPECTION PHOTOGRAPHS



1	2
3	X

PHOTO KEY

DESCRIPTION

NO.

1 Dam Overview

2 Upstream Face of Dam

3 Downstream Face of Dam

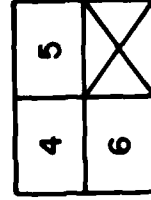

PHOTO KEY

DESCRIPTION

NO.

- 4 Spillway Structure
- 5 Spillway Exit Section
- 6 2½-Inch Lake Drawdown Valve

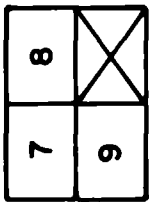
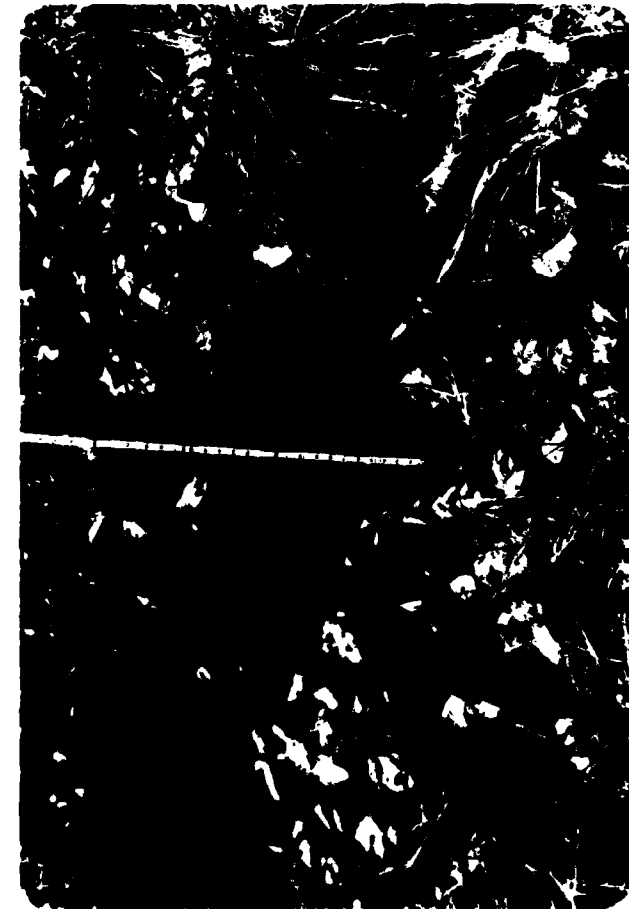

PHOTO KEY

<u>NO.</u>	<u>DESCRIPTION</u>
7	Erosion of Upstream Face
8	Seepage Area Near Downstream Toe
9	Seepage at Original Stream Channel

APPENDIX B

HYDROLOGIC AND HYDRAULIC ANALYSES

HYDROLOGIC AND HYDRAULIC COMPUTATIONS

1. The HEC-1 Dam Safety Version (July 1978, Modified 26 February 1979) program was used to develop inflow and outflow hydrographs and dam overtopping analyses, with hydrologic inputs as follows:

- a. Probable maximum precipitation (200 sq. mile, 24-hour value equals 25.5 inches) from Hydrometeorological Report No. 33. The precipitation data used in the analysis of the 1 percent chance (100-year frequency) flood was provided by the St. Louis District, Corps of Engineers.
- b. Drainage area = 0.025 square miles = 16 acres.
- c. SCS parameters:

$$\text{Time of Concentration } (T_c) = \left(\frac{11.9L}{H} \right)^{0.385} = 0.055 \text{ hours}$$

Where: T_c = Travel time of water from hydraulically most distant point to point of interest, hours
L = Length of longest watercourse = 0.133 miles
H = Elevation difference = 52 feet

The time of concentration (T_c) was obtained using Method C as described in Figure 30, "Design of Small Dams", by the United States Department of the Interior, Bureau of Reclamation, and was verified using average ditch velocity estimates and watercourse lengths.

Lag time = 0.033 hours (0.60 T_c)

Hydrologic Soil Group = 100% D (Gasconade Series per Missouri General Soil Map and field investigation; 25% impervious)

Soil type CN = 80 (AMC II, 1 percent probability flood condition)
 = 91 (AMC III, PMF condition)

2. The concrete spillway section is characterized by two control sections (C and D, Plates 4 and 6) and is of such complex nature that it is not possible to assess by inspection which section controls for various flow conditions. Therefore, the Corps of Engineers HEC-2 (Water Surface Profiles) Computer Program was utilized to develop the water surface profiles for several flow conditions, with the following results:

<u>Q</u> (cfs)	<u>Lake Level</u> <u>Elevation</u>	<u>Control</u> <u>Section</u>
0	620.0	-
4	620.4	C
10	620.7	C
30	621.1	C
50	621.4	C
100	622.1	D
150	622.6	D
200	622.9	D

These elevations and the corresponding discharges were entered into the HEC-1 Dam Safety Program on the Y4 and Y5 cards.

Mannings "n" values assumed in the HEC-2 analysis were:

<u>Reach</u>	<u>"n"</u>	<u>Section</u>
A-B-C	.015	Concrete
C-D	.030	Earth

3. The profile of the dam crest is irregular and flow over the dam cannot be determined by application of conventional weir formulas. Crest length and elevation data for the dam crest proper were entered into the HEC-1 Program on the \$L and \$V cards. The program assumes that flow over the dam

crest section occurs at critical depth and computes internally the flow over the dam crest and adds this flow to the flow over the spillway as entered on the Y4 and Y5 cards.

ANALYSIS OF DAM OVERTOPPING USING RATIOS OF PMF
 HYDROLOGIC-HYDRAULIC ANALYSIS OF SAFETY OF DEERWOOD LAKE NO. 3 DAM
 RATIOS OF PMF ROOTED THROUGH RESERVOIR

JOB SPECIFICATION

NO	NHR	NMIN	IDAP	IHR	IMIN	META	ICLI	IPRT	ISIAN
208	0	5	0	0	0	0	0	0	0
			JOPER	NWT	CRAT	TAREA			
			5	0	0	0			

MULTI-PLAN ANALYSES TO BE PERFORMED

NPLAN= 1 NRATIO= 4 LRTIO= 1

RTIOS= .30 .31 .50 1.00

SUB-AREA RUNOFF COMPUTATION

INFLOW HYDROGRAPH

ISTAQ	ICOMF	IECON	ITAPE	JPLT	JPRT	INAME	IETAB	IAUTO
INFLOW	0	0	0	0	0	1	0	0

HYDROGRAPH DATA

IHYD	ILAG	TAREA	SNAP	TRESA	TRSPC	RATIO	ISNOW	IEAME	LOCAL
1	2	.03	0.00	.03	1.00	0.000	0	1	0

PRECIP DATA

SPFE	FMS	R6	R12	R14	R48	572	FR6
0.00	25.50	102.00	120.00	130.00	0.00	0.00	0.00

LOSS DATA

LRGFT	STPKR	DCTKR	RTIOL	ERAIN	STRKS	RTIOL	STRTL	CNSTL	ALOMA	RTIMP
0	0.00	0.00	1.00	0.00	0.00	1.00	-1.00	-91.00	0.00	0.00

CURVE NO = -91.00 WETNESS = -1.00 EFFECT CN = 91.00

UNIT HYDROGRAPH DATA

TC= 0.00 LAG= .03

RECESSION DATA

STRIO= -1.00 GRCSN= -.10 RTIOR= 2.00

TIME INCREMENT TOO LARGE--(NHD IS GT LAG/2)

UNIT HYDROGRAPH 5 END OF PERIOD ORDINATES. TC= 0.00 HOURS. LAG= .03 VOL= 1.00
 144. 40. 8. 2. 0.

0							END-OF-PERIOD FLOW						
NO. DA	HR. MN	PERIOD	RAIN	EXCS	LOSS	COMP Q	NO. DA	HR. MN	PERIOD	RAIN	EXCS	LOSS	COMP Q
1.01	.05	1	.01	0.00	.01	0.	1.01	12.05	145	.22	.21	.01	34.
1.01	.10	2	.01	0.00	.01	0.	1.01	12.10	146	.22	.21	.00	40.
1.01	.15	3	.01	0.00	.01	0.	1.01	12.15	147	.22	.21	.00	41.
1.01	.20	4	.01	0.00	.01	0.	1.01	12.20	148	.22	.21	.00	41.
1.01	.25	5	.01	0.00	.01	0.	1.01	12.25	149	.22	.21	.00	41.
1.01	.30	6	.01	0.00	.01	0.	1.01	12.30	150	.22	.21	.00	41.
1.01	.35	7	.01	0.00	.01	0.	1.01	12.35	151	.22	.21	.00	41.
1.01	.40	8	.01	0.00	.01	0.	1.01	12.40	152	.22	.21	.00	41.
1.01	.45	9	.01	0.00	.01	0.	1.01	12.45	153	.22	.21	.00	41.
1.01	.50	10	.01	0.00	.01	0.	1.01	12.50	154	.22	.21	.00	41.
1.01	.55	11	.01	0.00	.01	0.	1.01	12.55	155	.22	.21	.00	41.
1.01	1.00	12	.01	0.00	.01	0.	1.01	13.00	156	.22	.21	.00	41.
1.01	1.05	13	.01	0.00	.01	0.	1.01	13.05	157	.26	.26	.00	48.
1.01	1.10	14	.01	.00	.01	0.	1.01	13.10	158	.26	.26	.00	49.
1.01	1.15	15	.01	.00	.01	0.	1.01	13.15	159	.26	.26	.00	50.
1.01	1.20	16	.01	.00	.01	0.	1.01	13.20	160	.26	.26	.00	50.
1.01	1.25	17	.01	.00	.01	0.	1.01	13.25	161	.26	.26	.00	50.
1.01	1.30	18	.01	.00	.01	0.	1.01	13.30	162	.26	.26	.00	50.
1.01	1.35	19	.01	.00	.01	0.	1.01	13.35	163	.26	.26	.00	50.
1.01	1.40	20	.01	.00	.01	0.	1.01	13.40	164	.26	.26	.00	50.
1.01	1.45	21	.01	.00	.01	0.	1.01	13.45	165	.26	.26	.00	50.
1.01	1.50	22	.01	.00	.01	0.	1.01	13.50	166	.26	.26	.00	50.
1.01	1.55	23	.01	.00	.01	1.	1.01	13.55	167	.26	.26	.00	50.
1.01	2.00	24	.01	.00	.01	1.	1.01	14.00	168	.26	.26	.00	50.
1.01	2.05	25	.01	.00	.01	1.	1.01	14.05	169	.33	.32	.00	59.
1.01	2.10	26	.01	.00	.01	1.	1.01	14.10	170	.33	.32	.00	62.
1.01	2.15	27	.01	.00	.01	1.	1.01	14.15	171	.33	.32	.00	62.
1.01	2.20	28	.01	.00	.01	1.	1.01	14.20	172	.33	.32	.00	63.
1.01	2.25	29	.01	.00	.01	1.	1.01	14.25	173	.33	.32	.00	63.
1.01	2.30	30	.01	.00	.01	1.	1.01	14.30	174	.33	.32	.00	63.
1.01	2.35	31	.01	.00	.01	1.	1.01	14.35	175	.33	.32	.00	63.
1.01	2.40	32	.01	.01	.01	1.	1.01	14.40	176	.33	.32	.00	63.
1.01	2.45	33	.01	.01	.01	1.	1.01	14.45	177	.33	.32	.00	63.
1.01	2.50	34	.01	.01	.01	1.	1.01	14.50	178	.33	.32	.00	63.
1.01	2.55	35	.01	.01	.01	1.	1.01	14.55	179	.33	.32	.00	63.
1.01	3.00	36	.01	.01	.01	1.	1.01	15.00	180	.33	.32	.00	63.
1.01	3.05	37	.01	.01	.01	1.	1.01	15.05	181	.20	.20	.00	44.
1.01	3.10	38	.01	.01	.01	1.	1.01	15.10	182	.40	.39	.00	68.
1.01	3.15	39	.01	.01	.01	1.	1.01	15.15	183	.40	.39	.00	75.
1.01	3.20	40	.01	.01	.01	1.	1.01	15.20	184	.59	.59	.00	104.
1.01	3.25	41	.01	.01	.01	1.	1.01	15.25	185	.69	.69	.00	127.
1.01	3.30	42	.01	.01	.01	1.	1.01	15.30	186	1.68	1.68	.00	274.
1.01	3.35	43	.01	.01	.01	1.	1.01	15.35	187	2.77	2.76	.01	471.
1.01	3.40	44	.01	.01	.01	1.	1.01	15.40	188	1.09	1.09	.00	282.
1.01	3.45	45	.01	.01	.01	1.	1.01	15.45	189	.69	.69	.00	167.
1.01	3.50	46	.01	.01	.01	1.	1.01	15.50	190	.59	.59	.00	126.
1.01	3.55	47	.01	.01	.01	1.	1.01	15.55	191	.40	.39	.00	88.
1.01	4.00	48	.01	.01	.01	1.	1.01	16.00	192	.40	.39	.00	78.
1.01	4.05	49	.01	.01	.01	2.	1.01	16.05	193	.30	.30	.00	64.
1.01	4.10	50	.01	.01	.01	2.	1.01	16.10	194	.30	.30	.00	60.
1.01	4.15	51	.01	.01	.01	2.	1.01	16.15	195	.30	.30	.00	59.

END-OF-PERIOD FLOW (Cont'd)

1.01	4.20	52	.01	.01	.01	2.	1.01	16.20	196	.30	.30	.00	59.
1.01	4.25	53	.01	.01	.01	2.	1.01	16.25	197	.30	.30	.00	59.
1.01	4.30	54	.01	.01	.01	2.	1.01	16.30	198	.30	.30	.00	59.
1.01	4.35	55	.01	.01	.01	2.	1.01	16.35	199	.30	.30	.00	59.
1.01	4.40	56	.01	.01	.01	2.	1.01	16.40	200	.30	.30	.00	59.
1.01	4.45	57	.01	.01	.01	2.	1.01	16.45	201	.30	.30	.00	59.
1.01	4.50	58	.01	.01	.01	2.	1.01	16.50	202	.30	.30	.00	59.
1.01	4.55	59	.01	.01	.01	2.	1.01	16.55	203	.30	.30	.00	59.
1.01	5.00	60	.01	.01	.01	2.	1.01	17.00	204	.30	.30	.00	59.
1.01	5.05	61	.01	.01	.01	2.	1.01	17.05	205	.24	.24	.00	49.
1.01	5.10	62	.01	.01	.01	2.	1.01	17.10	206	.24	.24	.00	47.
1.01	5.15	63	.01	.01	.00	2.	1.01	17.15	207	.24	.24	.00	46.
1.01	5.20	64	.01	.01	.00	2.	1.01	17.20	208	.24	.24	.00	46.
1.01	5.25	65	.01	.01	.00	2.	1.01	17.25	209	.24	.24	.00	46.
1.01	5.30	66	.01	.01	.00	2.	1.01	17.30	210	.24	.24	.00	46.
1.01	5.35	67	.01	.01	.00	2.	1.01	17.35	211	.24	.24	.00	46.
1.01	5.40	68	.01	.01	.00	2.	1.01	17.40	212	.24	.24	.00	46.
1.01	5.45	69	.01	.01	.00	2.	1.01	17.45	213	.24	.24	.00	46.
1.01	5.50	70	.01	.01	.00	2.	1.01	17.50	214	.24	.24	.00	46.
1.01	5.55	71	.01	.01	.00	2.	1.01	17.55	215	.24	.24	.00	46.
1.01	6.00	72	.01	.01	.00	2.	1.01	18.00	216	.24	.24	.00	46.
1.01	6.05	73	.06	.05	.02	7.	1.01	18.05	217	.02	.02	.00	43.
1.01	6.10	74	.06	.05	.02	9.	1.01	18.10	218	.02	.02	.00	40.
1.01	6.15	75	.06	.05	.02	9.	1.01	18.15	219	.02	.02	.00	37.
1.01	6.20	76	.06	.05	.02	9.	1.01	18.20	220	.02	.02	.00	35.
1.01	6.25	77	.06	.05	.01	10.	1.01	18.25	221	.02	.02	.00	33.
1.01	6.30	78	.06	.05	.01	10.	1.01	18.30	222	.02	.02	.00	30.
1.01	6.35	79	.06	.05	.01	10.	1.01	18.35	223	.02	.02	.00	28.
1.01	6.40	80	.06	.05	.01	10.	1.01	18.40	224	.02	.02	.00	26.
1.01	6.45	81	.06	.05	.01	10.	1.01	18.45	225	.02	.02	.00	25.
1.01	6.50	82	.06	.05	.01	10.	1.01	18.50	226	.02	.02	.00	23.
1.01	6.55	83	.06	.05	.01	10.	1.01	18.55	227	.02	.02	.00	22.
1.01	7.00	84	.06	.05	.01	10.	1.01	19.00	228	.02	.02	.00	20.
1.01	7.05	85	.06	.05	.01	11.	1.01	19.05	229	.02	.02	.00	19.
1.01	7.10	86	.06	.06	.01	11.	1.01	19.10	230	.02	.02	.00	17.
1.01	7.15	87	.06	.06	.01	11.	1.01	19.15	231	.02	.02	.00	16.
1.01	7.20	88	.06	.06	.01	11.	1.01	19.20	232	.02	.02	.00	15.
1.01	7.25	89	.06	.06	.01	11.	1.01	19.25	233	.02	.02	.00	14.
1.01	7.30	90	.06	.06	.01	11.	1.01	19.30	234	.02	.02	.00	13.
1.01	7.35	91	.06	.06	.01	11.	1.01	19.35	235	.02	.02	.00	12.
1.01	7.40	92	.06	.06	.01	11.	1.01	19.40	236	.02	.02	.00	12.
1.01	7.45	93	.06	.05	.01	11.	1.01	19.45	237	.02	.02	.00	11.
1.01	7.50	94	.06	.06	.01	11.	1.01	19.50	238	.02	.02	.00	10.
1.01	7.55	95	.06	.06	.01	11.	1.01	19.55	239	.02	.02	.00	9.
1.01	8.00	96	.06	.06	.01	11.	1.01	20.00	240	.02	.02	.00	9.
1.01	8.05	97	.06	.06	.01	11.	1.01	20.05	241	.02	.02	.00	8.
1.01	8.10	98	.06	.06	.01	11.	1.01	20.10	242	.02	.02	.00	8.
1.01	8.15	99	.06	.06	.01	11.	1.01	20.15	243	.02	.02	.00	7.
1.01	8.20	100	.06	.06	.00	11.	1.01	20.20	244	.02	.02	.00	7.
1.01	8.25	101	.06	.06	.00	11.	1.01	20.25	245	.02	.02	.00	6.
1.01	8.30	102	.06	.06	.00	11.	1.01	20.30	246	.02	.02	.00	6.
1.01	8.35	103	.06	.06	.00	11.	1.01	20.35	247	.02	.02	.00	5.

END-OF-PERIOD FLOW (Cont'd)

1.01	8.40	104	.06	.06	.00	11.	1.01	20.40	248	.02	.02	.00	5.
1.01	8.45	105	.06	.06	.00	12.	1.01	20.45	249	.02	.02	.00	5.
1.01	8.50	106	.06	.06	.00	12.	1.01	20.50	250	.02	.02	.00	4.
1.01	8.55	107	.06	.06	.00	12.	1.01	20.55	251	.02	.02	.00	4.
1.01	9.00	108	.06	.06	.00	12.	1.01	21.00	252	.02	.02	.00	4.
1.01	9.05	109	.06	.06	.00	12.	1.01	21.05	253	.02	.02	.00	4.
1.01	9.10	110	.06	.06	.00	12.	1.01	21.10	254	.02	.02	.00	4.
1.01	9.15	111	.06	.06	.00	12.	1.01	21.15	255	.02	.02	.00	4.
1.01	9.20	112	.06	.06	.00	12.	1.01	21.20	256	.02	.02	.00	4.
1.01	9.25	113	.06	.06	.00	12.	1.01	21.25	257	.02	.02	.00	4.
1.01	9.30	114	.06	.06	.00	12.	1.01	21.30	258	.02	.02	.00	4.
1.01	9.35	115	.06	.06	.00	12.	1.01	21.35	259	.02	.02	.00	4.
1.01	9.40	116	.06	.06	.00	12.	1.01	21.40	260	.02	.02	.00	4.
1.01	9.45	117	.06	.06	.00	12.	1.01	21.45	261	.02	.02	.00	4.
1.01	9.50	118	.06	.06	.00	12.	1.01	21.50	262	.02	.02	.00	4.
1.01	9.55	119	.06	.06	.00	12.	1.01	21.55	263	.02	.02	.00	4.
1.01	10.00	120	.06	.06	.00	12.	1.01	22.00	264	.02	.02	.00	4.
1.01	10.05	121	.06	.06	.00	12.	1.01	22.05	265	.02	.02	.00	4.
1.01	10.10	122	.06	.06	.00	12.	1.01	22.10	266	.02	.02	.00	4.
1.01	10.15	123	.06	.06	.00	12.	1.01	22.15	267	.02	.02	.00	4.
1.01	10.20	124	.06	.06	.00	12.	1.01	22.20	268	.02	.02	.00	4.
1.01	10.25	125	.06	.06	.00	12.	1.01	22.25	269	.02	.02	.00	4.
1.01	10.30	126	.06	.06	.00	12.	1.01	22.30	270	.02	.02	.00	4.
1.01	10.35	127	.06	.06	.00	12.	1.01	22.35	271	.02	.02	.00	4.
1.01	10.40	128	.06	.06	.00	12.	1.01	22.40	272	.02	.02	.00	4.
1.01	10.45	129	.06	.06	.00	12.	1.01	22.45	273	.02	.02	.00	4.
1.01	10.50	130	.06	.06	.00	12.	1.01	22.50	274	.02	.02	.00	4.
1.01	10.55	131	.06	.06	.00	12.	1.01	22.55	275	.02	.02	.00	4.
1.01	11.00	132	.06	.06	.00	12.	1.01	23.00	276	.02	.02	.00	4.
1.01	11.05	133	.06	.06	.00	12.	1.01	23.05	277	.02	.02	.00	4.
1.01	11.10	134	.06	.06	.00	12.	1.01	23.10	278	.02	.02	.00	4.
1.01	11.15	135	.06	.06	.00	12.	1.01	23.15	279	.02	.02	.00	4.
1.01	11.20	136	.06	.06	.00	12.	1.01	23.20	280	.02	.02	.00	4.
1.01	11.25	137	.06	.06	.00	12.	1.01	23.25	281	.02	.02	.00	4.
1.01	11.30	138	.06	.06	.00	12.	1.01	23.30	282	.02	.02	.00	4.
1.01	11.35	139	.06	.06	.00	12.	1.01	23.35	283	.02	.02	.00	4.
1.01	11.40	140	.06	.06	.00	12.	1.01	23.40	284	.02	.02	.00	4.
1.01	11.45	141	.06	.06	.00	12.	1.01	23.45	285	.02	.02	.00	4.
1.01	11.50	142	.06	.06	.00	12.	1.01	23.50	286	.02	.02	.00	4.
1.01	11.55	143	.06	.06	.00	12.	1.01	23.55	287	.02	.02	.00	4.
1.01	12.00	144	.06	.06	.00	12.	1.02	0.00	288	.02	.02	.00	4.

SUM 33.15 31.99 1.16 6625.
(842.7) (813.) (29.7) (187.80)

	PEAK	6-HOUR	24-HOUR	72-HOUR	TOTAL VOLUME
CFS	471.	70.	23.	23.	6616.
CMS	13.	2.	1.	1.	187.
INCHES		25.83	34.19	34.19	34.19
MM		657.41	868.45	868.45	868.45
AC-FT		34.	46.	46.	46.
THOUS CU M		43.	56.	56.	56.

SURFACE AREA=	0.	3.	4.	7.	10.
CAPACITY=	0.	19.	30.	85.	170.
ELEVATION=	600.	617.	620.	630.	640.

SUMMARY OF DAM SAFETY ANALYSIS
PMF

.....	INITIAL VALUE	SPILLWAY CREST	TOP OF DAM
	620.00	620.00	621.20
ELEVATION STORAGE	30.	30.	35.
OUTFLOW	0.	0.	39.

RATIO OF PMF	MAXIMUM RESERVOIR W.S. ELEV	MAXIMUM DEPTH OVER DAM	MAXIMUM STORAGE AC-FT	MAXIMUM OUTFLOW CFS	DURATION OVER TOP HOURS	TIME OF MAX OUTFLOW HOURS	TIME OF FAILURE HOURS
.30	621.19	0.00	35.	38.	0.00	15.83	0.00
.31	621.21	.01	35.	40.	.25	15.83	0.00
.50	621.46	.26	36.	162.	.92	15.67	0.00
1.00	621.64	.44	37.	376.	5.00	15.67	0.00

SUMMARY OF DAM SAFETY ANALYSIS
1% CHANCE FLOOD

.....	INITIAL VALUE	SPILLWAY CREST	TOP OF DAM
	620.00	620.00	621.20
ELEVATION STORAGE	30.	30.	35.
OUTFLOW	0.	0.	39.

RATIO OF PMF	MAXIMUM RESERVOIR W.S. ELEV	MAXIMUM DEPTH OVER DAM	MAXIMUM STORAGE AC-FT	MAXIMUM OUTFLOW CFS	DURATION OVER TOP HOURS	TIME OF MAX OUTFLOW HOURS	TIME OF FAILURE HOURS
1.00	620.86	0.00	34.	20.	0.00	12.50	0.00

**DAT
ILMI**