

LEVEL 1

12

TN 9-81



DEFENSE COMMUNICATIONS ENGINEERING CENTER

TECHNICAL NOTE NO. 9-81

FIBER OPTICS (OPTICAL WAVEGUIDES)
TECHNOLOGY - POTENTIAL APPLICATION
IN THE DCS

FEBRUARY 1981

SEP 30 1981

AD A104740

DTIC FILE COPY

APPROVED FOR PUBLIC RELEASE; DISTRIBUTION UNLIMITED

81 0 30 420

UNCLASSIFIED February 1981

SECURITY CLASSIFICATION OF THIS PAGE (When Data Entered)

REPORT DOCUMENTATION PAGE		READ INSTRUCTIONS BEFORE COMPLETING FORM
1. REPORT NUMBER DCEG-TN-9-81	2. GOVT ACCESSION NO. D-1104740	3. RECIPIENT'S CATALOG NUMBER
4. TITLE (and Subtitle) Fiber Optics (Optical Waveguides) Technology - Potential Application in the DCS		5. TYPE OF REPORT & PERIOD COVERED Technical Note
7. AUTHOR(s) Harris A. Stover		6. PERFORMING ORG. REPORT NUMBER
9. PERFORMING ORGANIZATION NAME AND ADDRESS Defense Communications Engineering Center Transmission Engineering Division, R200 1860 Wiehle Avenue, Reston, VA 22090		8. CONTRACT OR GRANT NUMBER(s) 15151
11. CONTROLLING OFFICE NAME AND ADDRESS Same as 9		10. PROGRAM ELEMENT, PROJECT, TASK AREA & WORK UNIT NUMBERS
14. MONITORING AGENCY NAME & ADDRESS (if different from Controlling Office)		12. REPORT DATE February 1981
		13. NUMBER OF PAGES 48
		15. SECURITY CLASS. (of this report) Unclassified
		15a. DECLASSIFICATION/DOWNGRADING SCHEDULE N/A
16. DISTRIBUTION STATEMENT (of this Report) Approved for public release; distribution unlimited.		
17. DISTRIBUTION STATEMENT (of the abstract entered in Block 20, if different from Report)		
18. SUPPLEMENTARY NOTES Review relevance 5 years from submission date.		
19. KEY WORDS (Continue on reverse side if necessary and identify by block number) Fiber Optics Applications Survivability Cable Communications Reconstitution Optical Waveguides Fiber Optic Technology		
20. ABSTRACT (Continue on reverse side if necessary and identify by block number) Fiber optics communications has developed very rapidly to the stage where it has economic advantages over other alternatives for many installations. The technology is well in hand and most problems have been solved. Fiber optics cables are small, lightweight, have broadbandwidths, freedom from interference and many other advantages. As telephone companies worldwide rush to install them, it is time to consider application to the DCS. In addition to potential economic advantages, survivability might be significantly enhanced.		

4/0101/

JSD

TECHNICAL NOTE NO. 9-81

FIBER OPTICS (OPTICAL WAVEGUIDES) TECHNOLOGY --
POTENTIAL APPLICATION IN THE DCS

FEBRUARY 1981

Prepared By Harris A. Stover

- Harris A. Stover

Approved for Publication:

FREDERICK L. MAYBAUM
Chief, Systems Engineering Division

FOREWORD

The Defense Communications Engineering Center (DCEC) Technical Notes (TN's) are published to inform interested members of the defense community regarding technical activities of the Center, completed and in progress. They are intended to stimulate thinking and encourage information exchange; but they do not represent an approved position or policy of DCEC, and should not be used as authoritative guidance for related planning and/or further action.

Comments or technical inquiries concerning this document are welcome, and should be directed to:

Director
Defense Communications Engineering Center
1860 Wiehle Avenue
Reston, Virginia 22090

EXECUTIVE SUMMARY

Fiber optics is an attractive medium for transmitting wideband communications, and this is particularly true for the type of digital signals which are expected to dominate the DCS in the future. This report is intended to introduce the reader to this new technology in sufficient detail to permit meaningful and reasonable consideration of potential applications in the DCS.

The fiber optics transmission medium has many properties which make the technology attractive for military applications. It provides an effective bandwidth that can be orders of magnitude greater than that of coaxial cables. It has transmission characteristics that are affected much less by environment, except for a strong ionizing radiation environment from which it can be shielded by burying the cable. It requires fewer repeaters than any other type of cable because its low losses permit the repeaters to be placed much farther apart. It provides electrical isolation, even between high voltage areas, because the transmission medium is an electrical insulator. It provides immunity to degradation from electromagnetic pulses (EMP). It eliminates ground loops which can be a serious problem with metallic cables. It provides immunity from short circuits. It is immune to sudden ionospheric disturbances which result from solar activity and can cause serious performance degradation in long lengths of other types of cable. It overcomes problems of power surges and lightning induced currents. It is immune to electromagnetic interference. There is no signal radiation, and there are no noise emission problems. There is no crosstalk. There are fewer storage problems than with coaxial cable because it is much smaller. It provides ease and economy of transport because of its light weight and small size. It can be hidden with complete freedom from detection with metal detectors. Under certain conditions it is physically more rugged than coaxial cable, e.g., during tests it has continued to be useful during and following being repeatedly run over by cars and trucks over a long period of time. It provides freedom from sparking and therefore cannot cause explosions. It does not attract lightning. The bandwidth of installed systems usually can easily be upgraded by replacing electronics used with the same cable. There are no terrain clearance problems as encountered with microwave radio. It has none of the frequency allocation problems associated with any type of radio transmission. It is one of the most rapidly developing technologies, with rapid improvements in quality, production costs, reliability, connector methods, methods of deployment, etc., which have already made it cost competitive with many other types of cable and some radio systems for a wide range of applications.

Whenever the DCS must expand or extend cable service, or replace existing cable, the special characteristics and rapidly declining costs of fiber optics cable, along with its rapidly increasing reliability, indicate that its use should be carefully considered. In addition to consideration for replacing other types of cables, fiber optics, because of special properties, should be investigated for use in applications where other types of cable were not considered because they were obviously unsatisfactory. (See Survivability Section.)

The question of whether any type of cable, including fiber optics cable, is a viable alternative to other media (such as microwave radio, tropospheric scatter, or satellite communications) for any particular application depends upon a large number of parameters, and it is very controversial. It is a question that is much too complex and controversial to consider in this summary, but discussion is provided in the body of the report.

As telephone companies throughout the world rush to install fiber optics, it is the conclusion of the author that there are applications for fiber optics cable in the DCS; but in order to make the most effective use of this technology, studies should be undertaken to answer a number of questions of the type given in the Conclusions and Recommendations section of this report. Furthermore, because of the differences between military and civilian applications, it is very likely that development programs are needed to develop the best means of deploying or installing fiber optics communications to satisfy military requirements.

TABLE OF CONTENTS

	<u>Page</u>
EXECUTIVE SUMMARY	iii
I. INTRODUCTION	1
II. BACKGROUND	2
III. FIBER OPTICS TECHNOLOGY	4
1. Refraction and Reflection	4
2. Losses	7
3. Light Sources	9
4. Light Detectors	12
5. Splices and Connectors	14
6. State-of-the-Art	15
IV. FIBER OPTICS APPLICATIONS	17
1. Commercial Uses	17
2. Advantages for Military Communications	22
3. Current Military Fiber Optics Systems Applicable to the DCS	27
4. Other Applications of Optics	29
V. SURVIVABILITY IN MILITARY APPLICATIONS	31
VI. CONCLUSIONS AND RECOMMENDATIONS	35
ADDENDUM	40
ACKNOWLEDGEMENT	42
DISTRIBUTION	43

LIST OF ILLUSTRATIONS

<u>Figure</u>	<u>Title</u>	<u>Page</u>
1	Refraction of Light	4
2	Step Index Optical Fiber	5
3	Surface Emitter	11
4	Edge Emitter	11

I. INTRODUCTION

Fiber optics (optical waveguides) is an attractive medium for transmitting wideband communications. This is particularly true for digital signals which are expected to dominate DCS communications in the future. In fiber optics technology, light beams modulated by the information to be communicated are guided from the transmitting location to the receiving location by thin fibers of a transparent dielectric medium (glass or plastic). These fibers began attracting the attention of communications engineers in the 1960's when their losses were approximately 1000 dB/km. At the present time, losses as low as 0.2 dB/km are being reported in the research literature. As a result of these developments, and those in the related technology (splicing, connectors, optical transmitters and optical receivers), optical fibers are beginning to shoulder the burden of telephone, television and data traffic in the telephone networks, and also for various closed circuit applications. Their influence in wideband communications is expected to grow enormously in years to come, and it is anticipated that they will open up services not previously practical to provide, and perhaps they will provide services that haven't even reached the dream stage. As telephone companies throughout the world rush to install fiber optics communications, primarily for economic reasons, but sometimes because of other characteristics such as freedom from interference or immunity from lightning, it is time to consider application of this rapidly growing technology to the DCS.

This report is intended to introduce the reader to this new technology in sufficient detail to permit meaningful and reasonable consideration of potential applications in the DCS. Historical background is provided along with a brief discussion of the fundamental physics involved. A summary of the state-of-the-art in fiber optics cables is provided, which when considered along with related discussions of cable losses, light sources, light detectors, splices, connectors, and commercial applications of fiber optics should give the reader a good understanding of the present state of the fiber optics technology. A section is given on the properties of fiber optics that make them attractive for military communications. It will provide insight into functional and technical advantages of applying the technology in the DCS in addition to economic advantages of some applications. A brief section discusses current military fiber optics systems applicable to the DCS.

The survivability of fiber optics communications for long haul DCS applications is somewhat controversial; there are some divergent opinions as to the survivability of any type of cable in long haul communications applications. The section on survivability of fiber optics communications introduces and discusses survivability of fiber optics communications, and indicates many possibilities where fiber optics might significantly enhance the survivability of the DCS.

II. BACKGROUND

Although glassmakers were probably aware of it earlier, a little more than a century ago the phenomenon of light-guiding in a dielectric medium was demonstrated after it was found that light was transmitted by total internal reflection in a stream of water flowing through a hole in a container. This was demonstrated to the British Royal Society by John Tyndall in 1854. In the mid-1960's, serious consideration was given to the use of dielectric fibers to carry communications signals. In this application, at least for long distances, low loss is essential. In the late 1960's, typical fiber losses were more than 1000 dB/km, but it was believed that much lower losses could be achieved with purer materials. A breakthrough occurred in 1970 when Corning Glass Works announced achievement of fiber losses under 20 dB/km. Since then development of low loss fibers has been very rapid. Various commercially available fibers now have losses of 3 to 6 dB/km; i.e., after traveling one kilometer one-fourth to one-half of the light entering the fiber/core is still present. Fibers in the laboratories have losses of only 0.2 dB/km and 3000 MHz-km bandwidths, and further improvements are expected. (At 0.2 dB/km, after 50 km or 31 miles, there will be 10 percent of the transmitted signal remaining.)

To make effective use of optical fibers in a communications system, light sources and light detectors are also required. If light is to be efficiently launched into a fiber, the source must be small. Typical commercially available fibers have cores of 50 micrometers diameter and cladding of 125 micrometers diameter. Because of material dispersion within the fiber (different wavelengths travel at different velocities) the light must have a narrow spectral width. The primary light sources used are the light emitting diode (LED) and the injection laser diode (ILD). These are semiconductor devices whose light output is controlled by the amount of current driving them. The beam of the ILD is far more directional than the LED, making it easier to couple into the fiber, and its coherent output is spectrally much narrower than that of the LED. One of the early problems of the ILD was its short lifetime in 1970 of about 2 hours; efforts to extend its lifetime have resulted in extrapolated lifetimes of more than 1 million hours for those available now. The ILD has a temperature sensitivity not shared by the LED. Receivers commonly use photodiodes, either positive-intrinsic-negative (PIN) photodiodes or avalanche photodiodes (APD). These devices, the LED, ILD, APD, and PIN photodiodes, resulted, in part, from the research in semiconductors that developed transistors and integrated circuits.

As a result of extensive research and development activities in recent years, developments of all areas of the technology including materials, fabrication methods, splicing methods, connectors, transmitters, and receivers, have progressed rapidly in a well coordinated pattern. Unlike the development of the transistor where manufacturers of vacuum tubes were not a motivating force in its development, traditional cable suppliers and cable connector suppliers are strongly participating in fiber optics development. Other organizations with special knowledge of the needed technologies also

participate. The important theories have developed well, and the technology for fabricating each of the different devices is showing excellent progress. Costs have decreased rapidly. Costs of the fibers are now so low that they are dominated by the cost of cabling them. Even as applications grow very rapidly at the somewhat less desirable higher frequencies of systems now being fielded, relatively new knowledge about optimum frequencies for low loss and low dispersion has stimulated activity to exploit the preferred lower frequency range.

At first it was felt that optical fibers would be resistant to effects of atomic radiation, but it was found that some of them are extremely sensitive to even moderate doses of atomic radiation. Now, methods of hardening against atomic radiation are developing well, and it is also recognized that the cable can be shielded from the radiation by burying it.

III. FIBER OPTICS TECHNOLOGY

1. REFRACTION AND REFLECTION

One of the fundamental parameters of optical materials is their index of refraction, n . This is the ratio, $n = c/v$, of the speed of light in a vacuum, c , to the speed of light, v , in the material. Now consider Figure 1

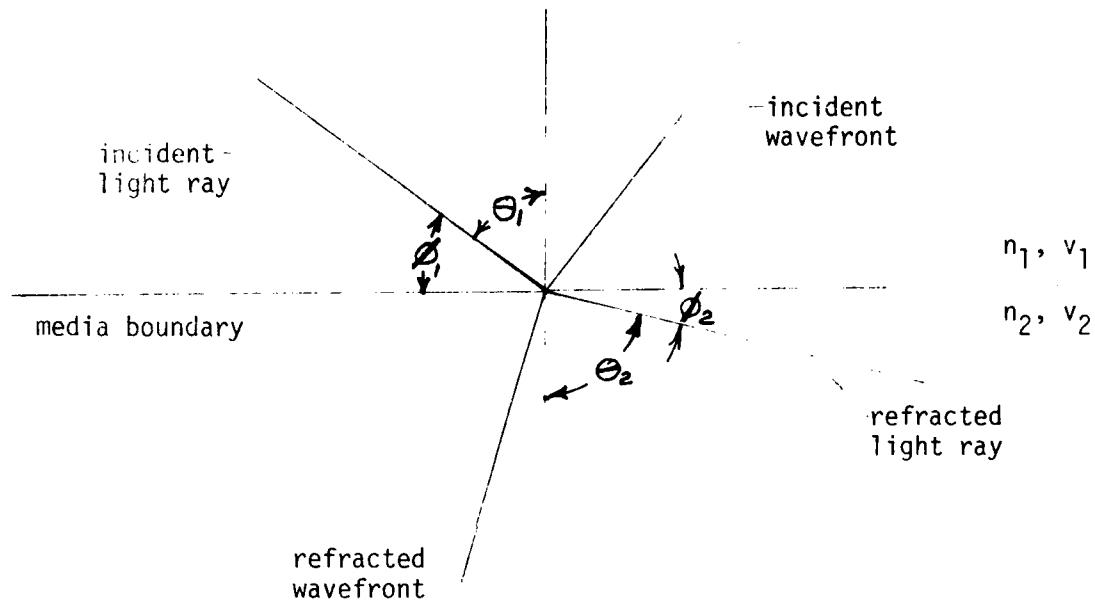

Figure 1. Refraction of Light

where the horizontal line is a boundary between two transparent materials with differing coefficients of refraction, n_1 and n_2 , and hence different velocities of the light, v_1 and v_2 .

An incident light ray in medium 1 will have a wavefront which is perpendicular to the velocity of the wave (the path which we call a ray), and the refracted light in medium 2 will have a wavefront perpendicular to the velocity of the wave in that medium. The wavefront is continuous across the boundary as shown in Figure 1, although it does have a bend, or kink, at the boundary. The velocity of the wavefront along the boundary between the two media is the same for the refracted light in medium 2 as it is for the incident light in medium 1. If θ_1 is the angle between the incident ray and the normal to the boundary, θ_2 is the angle between the refracted ray and the normal to the boundary, and V is the velocity of the wavefront along the boundary; then $v_1 = c/n_1 = V \sin \theta_1$ and $v_2 = c/n_2 = V \sin \theta_2$. Therefore, $\sin \theta_1 / \sin \theta_2 = v_1 / v_2 = n_2 / n_1$. This is Snell's law.

notice that if θ_2 is 90 degrees, the refracted wave is parallel to the boundary. The angle of the incident wave, θ_1 , that causes this to happen is called the critical angle, θ_c , and from Snell's law, $\theta_c = \arcsin(n_2/n_1)$. For any incident angle greater than θ_c there will be no refracted ray and the incident light will be reflected at the boundary between the media. This is the characteristic that is used in a step index optical fiber where a glass cladding material with index of refraction n_2 surrounds a core material with an index n_1 which is somewhat higher. This is shown in Figure 2.

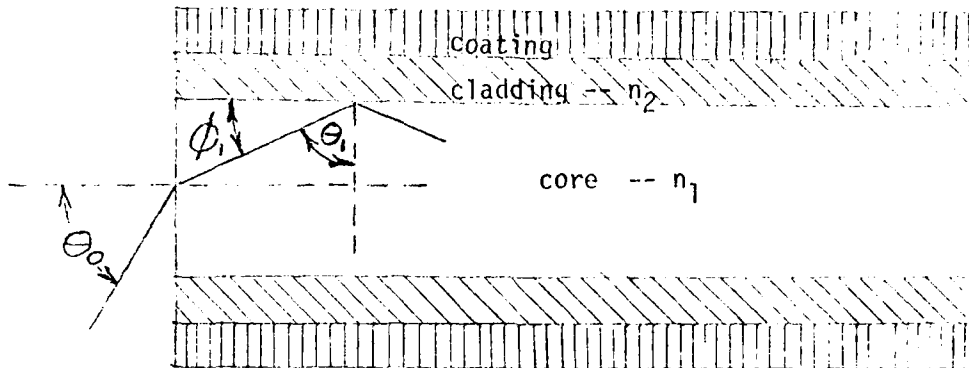

Figure 2. Step Index Optical Fiber

Figure 2 shows a light ray striking the end of the fiber cable, entering the cable and being reflected by the boundary between the core and the cladding. The critical angle for this boundary as measured between the incident ray and the normal to the boundary is $\theta_c = \arcsin(n_2/n_1)$. If ϕ_c is the critical angle when measured between the ray and the axis of the fiber instead of the normal to the boundary, then $\phi_c = 90^\circ - \theta_c$ making $\cos \phi_c = \sin \theta_c = (n_2/n_1)$. The same ϕ_c is also the critical angle for internal reflection from this same boundary in the fiber when measured relative to the normal of an end surface (where the end surface is perpendicular to the axis of the fiber). If we assume that the medium outside the fiber is a vacuum (or air), $n_0 = 1$, then by Snell's law the corresponding angle, θ_0 , is given by $\sin \theta_0 / \sin \phi_c = n_1$. But $\cos \phi_c = (n_2/n_1)$ so that

$$\sin \phi_c = \sqrt{1 - (n_2/n_1)^2}, \text{ and } \sin \theta_0 = n_1 \sqrt{1 - (n_2/n_1)^2}.$$

This value, $\sin \theta_0 = \sqrt{n_1^2 - n_2^2}$, is called the numerical aperture (NA). It is important because any ray striking the end of the fiber within an angle θ_0 of the axis of the fiber (or within a cone with an apex angle of $2\theta_0$) will propagate down the fiber by total internal reflection while rays striking the end of the fiber at an angle greater than θ_0 will enter the cladding. The numerical aperture is a measure of the capability of the fiber to capture rays impinging on it. It represents the light-collecting capability of the fiber.

An important characteristic of the step index fiber is that rays impinging on the end of the fiber at different angles will travel different distances in passing from one end of the fiber to the other. This is called modal dispersion (as differentiated from material dispersion). If $n_2/n_1 = .987$, then the critical angle θ_c is 80.75 degrees and critical angle ϕ_c is 9.25 degrees. For this example, a ray traveling at the critical angle down the fiber will travel 1.3 percent farther than a ray which travels directly down the axis without being reflected back and forth by the boundary between the core and the cladding. (Another type of dispersion, called material dispersion, results from different wavelengths traveling at different speeds and can be minimized by using a monochromatic light source.)

Another type of fiber, the graded index fiber, reduces the modal dispersion problem of step index fiber. In graded-index fiber the index of refraction varies with the distance from the core center according to the equation $n_r = n_1[1-M(r/a)^\alpha]$, where n_1 is the index at the core center, M is the maximum relative index change from core center to cladding, r is the radial position from the core center, a is the core radius, and α determines the profile. Thus, the velocity of propagation along the fiber increases with the distance from the core center. For this type of fiber, the rays gradually bend to stay within the fiber instead of undergoing the sharp reflection of the step-index fiber. The distance that a ray travels in a direction perpendicular to the fiber axis depends upon the incident angle of the ray striking the fiber. With this type of path, the rays that travel the maximum transverse distance, i.e., have the greatest component of travel distance in a direction perpendicular to the axis of the fiber, also have the greatest proportions of their axial components of travel farthest from the center of the fiber where the speed is the greatest. This compensates for the longer path that these rays travel, thereby reducing the amount of dispersion.

Communications engineers are generally quite familiar with Maxwell's electromagnetic field equations and the way they govern the propagation of microwaves through waveguides. These same equations govern the propagation of light in an optical fiber waveguide. They can be used to predict the number of modes and the angles at which light rays propagate along the fibers. The number of modes that a step index fiber can support is related to a dimensionless number, V , called the normalized frequency ($V = (\pi d/\lambda) \sqrt{n_1^2 - n_2^2}$) where d is the core diameter and λ is the wavelength of the light). This number of modes, M , called the mode volume, is given by $M = V^2/2$ for step index fiber and by $M = V^2/4$ for parabolic graded index fiber. In particular, if the wavelength is great enough or the core diameter is made small enough or the difference in refractive index between the core and the cladding is small enough (resulting in a small numerical aperture), only a single mode (an axial ray) can propagate down the fiber. This is called single-mode fiber. For a wavelength of 820 nanometers and currently used core and cladding indices the core diameter is only about 2.5 micrometers. Since there is no modal dispersion it offers the ultimate in bandwidth and reduces losses from dispersion, but there are serious problems with injecting light into such a small core, and there is also a problem of aligning and making splices with such a small core. As will be evident later in the report, a most interesting characteristic of single mode fiber is its very low loss in the wavelength region of 1.2 to 1.6 micrometers,

where there is also very low material dispersion in either pure or doped silica glasses. At these wavelengths, with suitable light sources and detectors, single mode fibers can provide very high information capacity per fiber which cannot be attained with multimode fibers; but splicing the very small core size single mode fibers is extremely difficult.

Maxwell's equations also predict that light may propagate in the cladding. Since this field vanishes exponentially across the cladding, it is called the evanescent field. It is this evanescent property of the cladding that allows fibers to be produced with practical cladding thickness. If the cladding is too thin, there may also be some leakage or radiation outside the cladding. Because of the very small core diameters of single mode fibers, relative to the wavelength, a considerable portion of the energy propagates in the cladding of single mode fibers.

Note: Several years ago designers working on fiber optics cables used bundles of several fibers to carry a single communications signal because single fiber technology had not been sufficiently developed. Now development has reached the point where the trend is definitely toward using a single multi-mode fiber for each communications signal (which might consist of many multiplexed communications channels), particularly for longer distance communications. However, there are still many applications for multiple fiber bundles. They are very effective for collecting light in a formatted form for scanners, card readers, medical instruments, etc., and for those applications, they presently have a very definite price advantage. Perhaps as technology further develops, the single mode fibers will provide even greater spacing between repeaters and greater information bandwidths; but at present, single fiber multi-mode transmission seems to be the best choice for most DCS applications. Other sections of the text will help to explain this.

2. LOSSES

Practical optical fibers have losses which are related both to the materials and to the dimensional characteristics of the fiber. In general, these losses can be characterized as being due either to scattering where the light is lost (or radiated) from the core or cladding or due to absorption by the material itself. Roughness of the boundary between the core and the cladding, and scattering due to compositional variations in the refractive index can cause loss because some of the light rays will strike the boundary at an angle which will allow partial penetration, and all of the energy will not be retained within the core (or the evanescent field of the cladding) of the fiber. Part of those rays remaining in the fiber will be scattered back toward the source. Some of the compositional variations are caused by thermal agitation that exists when the glass is soft and this variation is frozen into place when the glass hardens. This is fundamental and cannot be eliminated. The loss due to scattering is inversely proportional to the fourth power of the wavelength; i.e., it decreases for longer wavelengths of light.

Absorption of the light energy occurs when the light photons contain the correct amount of energy to excite electrons in the material. In a transparent silica of pure silica, the oxygen ions have very tightly bound electrons, and

only ultraviolet light photons have enough energy to be absorbed, so that in high silica the absorption is negligible at the infrared wavelengths of primary interest for communications. However, there are two other types of absorption that are significant. One is due to impurities and the other is due to atomic defects. Impurity absorption at the communications wavelengths in conventional alkali silicate glasses traditionally comes from Fe, Cu, Co, V, and Cr. These impurities must be kept below the 10 part per billion (ppb) range in order to have low loss (but may cause no loss in high silica glasses). At certain wavelengths, levels of 1 ppb of some of these elements can increase absorption loss by as much as 1 dB/km. An impurity that definitely causes loss in all types of fiber is the OH radical, sometimes referred to as "water". Its fundamental resonance is at 2700 nanometers (nm), but it also has significant overtones at 1400, 950, 875, 825, and 725 nanometers. The level of OH absorption can be controlled by processing parameters so that ultimately the OH absorptive loss could be negligible at the wavelengths of primary interest for communications. It has a minimum in the valleys between the peaks, e.g., from 1200 to 1300 nanometers.

It should be mentioned that some desirable changes, in addition to adjustments of the index of refraction, can be produced by using compound glasses rather than high-silica glass. These compound glasses are doped with significant percentages of modifiers such as oxides of sodium, calcium, boron, germanium, or phosphorous. Adjusting the amounts of these dopants controls the index of refraction, but selecting the combination of dopants to use can also permit the design of glasses for particular characteristics. This can sometimes be useful in combating another type of absorption, that due to atomic defects. At first it was felt that optical fibers would be resistant to effects of nuclear radiation, but it was found that some of them are extremely sensitive to even moderate doses of nuclear radiation. Radiation has two primary optical effects on this use of glass fibers: (1) it induces luminescence (an interfering signal), and (2) it increases absorption. Both effects result from the nuclear radiation (or other type of ionizing radiation, e.g., gamma or x rays, electrons, neutrons, protons). Light is generated in the fiber both in the form of Cerenkov radiation during the irradiation and as fluorescence when generated electrons and holes recombine. The effects of both of these types of luminescence can be minimized by appropriate filtering. In addition, radiation induced defect centers may have absorption bands which increase the optical attenuation in the fiber. This is a much more serious problem, and the nature of the damage is sensitive to such parameters as the impurity content, temperature, and the amount and type of dopant. Promising work in the field of reducing the adverse effects of atomic radiation on optical fibers is continuing, but considerable work is still needed. Many future fiber optics systems may operate in the near infrared (between 1.3 and 1.55 micrometers) spectral region to take advantage of the low intrinsic loss and low material dispersion afforded in that region. However, although radiation induced absorption is greatest in the ultraviolet, some fiber glasses exhibit radiation-induced absorption bands centered near 1.5 micrometers in the infrared. Even at relatively moderate radiation doses, these radiation induced attenuations can far exceed the intrinsic loss of low loss fibers. Hopefully, additional studies will reveal the reasons for this and open the way to development of optical fiber systems which are hardened against nuclear radiation. Some of the early measurements that were made between 0.4 and 1.1

micrometers indicated a general decrease in damage with increasing wavelength and it was anticipated that considerable advantage would be obtained by operating in the 1.3 to 1.55 micrometer range. More recent measurements extended to 1.7 micrometers have demonstrated a minimum in radiation induced loss near 1.1 micrometers in some fibers, and some Ge-doped silica core fibers not codoped with P have a broad minimum in induced loss extending from 1.1 to 1.5 micrometers.

In the case of single mode optical fibers where a considerable portion of the energy propagates in the evanescent field of the cladding as discussed in the previous section, losses in the cladding might be of equal or greater importance than losses in the core itself.

Some characteristic differences between fiber optics cables and coaxial or twisted pair cables should be noted. In coaxial or twisted pair cables, the losses are a function of the bandwidth with larger bandwidths producing greater losses. In fiber optics cables, the losses are nearly independent of the bandwidth (usually expressed as dB/km) and depend only on the length of the cable, so that the familiar tradeoff between losses and bandwidth as is required for coaxial or twisted pair cable is not necessary with fiber optics cables. However, because fiber optics cables do have dispersion, there is still a degradation of bandwidth with distance. For low loss long range cable, this is sometimes expressed in terms of dispersion as ns/km. In short range cable it is frequently given as (MHz)(km) or (MB/s)(km).

3. LIGHT SOURCES

Two major types of solid-state emitters find use in fiber optics systems. These are light-emitting diodes (LED's) and injection laser-diodes (ILD). Strictly speaking, ILD's are a special subclass of LED's but are classified separately, because, like their non-solid-state cousins, they produce light amplification by stimulated emission of radiation. Conventional LED's merely generate light directly by biasing a P-N semiconductor junction.

To explain how the LED works, let's review semiconductor materials briefly. A pure crystal theoretically has all of its atoms' outer electrons bonding the atoms together. In an N-type material a dopant is added which has extra free electrons not needed for the bonds, while a P-type material does not have enough electrons to fill all the bonding sites. The vacancies in bonding sites are called holes and act much like particles with a positive charge. When the P-material with positively charged holes meets the N-material with negatively charged free electrons, a PN junction is formed which has a depletion region void of free electrons and holes. To be free and a carrier of electricity, the electron must possess more energy than if it were part of a bond. Those that are part of the bond are in the valence band while those available to carry electricity are in the conduction band where they have more energy than in the valence band. Free electrons and holes are attracted to one another. If they come together, the electron will drop into the hole and they both seem to disappear. Normally this does not happen because they cannot cross the depletion region and are held apart. When a bias voltage is applied in the right direction it overcomes the depletion region causing a bias current to flow. Free electrons and holes move across the junction. When they meet, they

combine and the electron moves from the conduction band to the lower energy valence band giving up a photon of energy. In the LED the electrons give up differing amounts of energy, and since the wavelength is inversely proportional to the energy, the emitted light will be of several wavelengths. The particular wavelengths depend upon the material and dopants used. Two broad classes of solid-state emitters are surface emitters and edge emitters as illustrated in Figures 3 and 4.

The injection laser (Light Amplification by Stimulated Emission of Radiation) diode (ILD) is a semiconductor chip similar to the edge emitter LED. Unlike the LED, the laser emits coherent, monochromatic light; i.e., all the waves are in phase giving very nearly monochromatic light. It emits a narrow intense beam of light that does not spread like an LED's light. It is more powerful than an LED (up to 20 mW vs typically 1 mW or less) and its narrow beam allows a greater percentage of its energy to be coupled into the fiber. It is more expensive than the LED, is temperature sensitive and requires a more complex electronic drive system for operation. In addition, it is generally less reliable and has a shorter expected lifetime. Laser diodes tend to exhibit modal instability when their bias is varied so they work best in pulsed applications where they are alternately delivering full output or zero output. This makes them fine for digital systems, but less desirable for some analog systems. Pulsed operation of laser diodes also helps them run cooler which improves reliability. Their short risetime increases the channel capacity compared to LED's.

Manufacturers have made significant progress in improving the reliability of lasers (in only 9 years going from a few seconds to nearly a hundred years), but their reliability still falls short of that of the best LED's which have rated lives of well over 100 years. At ITT's microwave and Electro-Optic Division in England, of 120 laser diodes turned on 5 years ago, only 3 have failed, giving up to 1.4 million hours of operation at room temperature. They have shown typical threshold increases of 25 to 30 percent in 4 years.

The common materials for laser diodes for operation at approximately 800 nm are GaAs and GaAlAs, but the need for operation at longer wavelengths has started an investigation into quaternary materials. At least three companies are already selling InGaAsP diodes capable of operation at 1200 nm or longer wavelengths. Bell Laboratories managed a peak spectral wavelength of 1550 nm, opening the possibility of transmission through very low attenuation fibers. General Motors Corporation researchers have reported a lead-salt light-emitting diode that operates at room temperature producing a 4600 nm wavelength. Previous attempts using such lead-salt diodes have required cryogenic cooling, but by using devices fabricated from high quality lead-sulfide-selenide single crystals, the junction resistance rose to as much as 100 ohms compared with only a few ohms in the past. So far, power output is only a few hundred nanowatts. However, it is hoped that use of the far infrared portion of the spectrum will permit fiber optics communications systems with attenuation losses orders of magnitude less than the few tenths of a dB/km obtained in the coming 1500 nm region.

The difference in construction between a laser diode and an edge emitting LED is not great. The laser diode has two slightly different P-regions with the

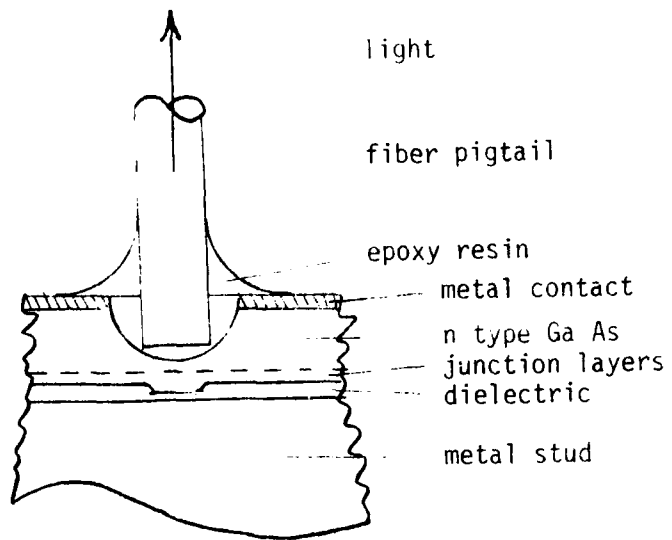

Figure 3. Surface Emitter

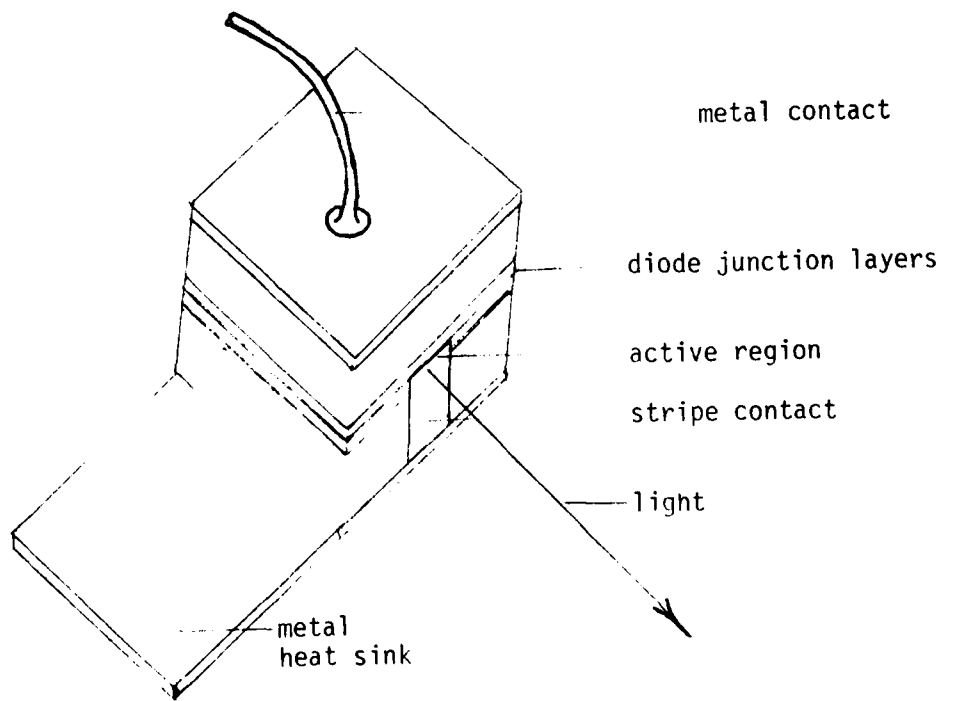

Figure 4. Edge Emitter

active region in the center P-area which has partially reflecting mirror-like ends formed by cleaving the die at each end surface. The light resulting from electrons combining with holes is partially trapped in the active region by the mirror-like end walls. As the photons reflect back and forth they can stimulate an electron to combine with a hole producing a new photon exactly like the first. A strong bias current supplies many holes and electrons into the active region and when existing photons stimulate new photons, amplification occurs. Since not all of the light is trapped in the active region, some is emitted from the mirrorlike end surfaces in a strong, narrow beam of laser light. In addition to injecting the electrons and holes, the layers on either side of the active region confine the electrons and holes and the generated light to the active region.

For short distance fiber optics communications, the relatively inexpensive LED is probably the better choice for a light source, while for long paths where maximum advantage is to be taken of the low-loss properties of the cable, a laser diode should be used.

When exposed to nuclear radiation, fiber optics light sources undergo neutron degradation which significantly reduces the optical power output. Since light sources will usually be collocated with associated light detectors, it can usually be assumed that they will be protected in a similar manner to the light detectors.

4. LIGHT DETECTORS

There are basically four types of light detectors used for fiber optics communications. These are the PIN photodiode, the avalanche photodiode (APD), the phototransistor, and the photodarlington transistor. The PIN photodiode has a layer of undoped or intrinsic "I" material sandwiched between a layer of P-material and a layer of N-material. When light falls on the I-material, the photons are absorbed by electrons in the valence band. This extra energy allows the electrons to break free of the valence band and enter the conduction band. The result is a hole-electron pair that permits the diode to conduct. The photodiode provides no amplification since a photon is required to generate each hole-electron pair (and not all photons generate such pairs), and for this reason it is not sensitive to weak signals. It is inexpensive, has a fast response time and is easy to use, requiring a bias as small as 5 volts.

The avalanche photodiode detector (APD) behaves analogously to a photomultiplier tube, generating a current many times greater than the current produced by the incident photons. Because of its photomultiplication properties, the silicon avalanche photodetector increases the light wave system's sensitivity far beyond that of a conventional PIN photodetector. The APD is composed of four layers: an n-layer, a p-layer, an i-layer and a p+ low resistivity layer. It is operated at a high voltage -- 100 to 300 volts -- just below the point of avalanche breakdown. Light enters through the n layer and penetrates the intrinsic region where it generates hole-electron pairs. Biasing voltage is applied so that the holes are attracted to the p+ region, and electrons are attracted to the p-region creating a current. The more intense the light, the greater the number of hole-electron pairs, and the greater the current. The collision of electrons in the p-region generates more

hole-electron pairs producing an avalanche effect that gives the device high gain. A potential problem with avalanche photodetectors can be small localized voltage breakdowns that occur at crystal lattice imperfections, etc. Because the avalanche photo detector must operate near its breakdown voltage, it is possible for these imperfections to produce spikes in its output. Since the spikes can appear as real data, they must be minimized to assure acceptable bit error rates. They are sensitive to variations in temperature and require compensating circuitry. APD's are also faster at turning on and off than PIN photodiodes.

The phototransistor is similar to other bipolar transistors in that it is formed by three alternately doped materials. In the phototransistor, light photons create carriers in the base which serve as the current to turn on the transistor, although the light sometimes controls the collector instead of the base. A photodarlington transistor is actually two transistors connected together in a Darlington arrangement on the same chip, providing even more amplification. The amplification makes the phototransistor more sensitive than the photodiode, and it provides a better signal to noise ratio at the expense of speed. Although it requires a somewhat more complex bias circuit than the PIN photodiode, it does not require as complex a circuit as the APD.

Detectors are usually broadband devices. Until recently the preferred material for detectors was silicon. Though silicon PIN diodes are well matched spectrally to systems operating in the 800 to 900 nm range, their response falls off at wavelengths above 1100 nm. As with emitting devices, research activity for light detectors has switched to InGaAsP diodes for long-wavelength applications. (The possibility exists for the same type of diode to be used as both source and detector.)

The high sensitivity which is required for optimum electrical performance makes fiber optics receivers vulnerable to the effects of nuclear radiation, and for military application hardening techniques should be applied where needed. Short term ionization induced problems include high-radiation induced photocurrents in the detectors, transient response of receiver input circuitry and large dynamic range required because of fiber fluorescence and detector photocurrents. Problems resulting from permanent damage are decreased detector sensitivity, increased loading of the detector by the input amplifier, and decreased performance of the receiver due to degradation of its semiconductor components. For receivers which must operate through a transient radiation event, the APD is not a good choice for a detector, unless the radiation is less than 1 rad (Si)/sec, because the avalanche multiplication process affects radiation generated currents in addition to the optically generated currents. Operation during a transient radiation event (primarily for short link designs) can be improved by using PIN photodiode detectors and by using two optical inputs in a differential input amplifier design that permits common mode photocurrents and fiber fluorescence to be partially cancelled. For long links, fiber losses due to radiation and reduced receiver sensitivity after permanent degradation are the dominant factors.

The APD and PIN photodiodes seem to be preferred detectors, at present, for receiving signals generated by GaAlAs laser diodes. For the shorter cable runs, the simpler PIN photodiodes are probably the better choice, but for long cable

runs where it is desired to take maximum advantage of the lower loss of the cable, the APD is probably the right choice. For radiation environments of greater than 1 rad (Si)/sec the APD is not satisfactory and the PIN photodiode should be used.

5. SPLICES AND CONNECTORS

Splices of fiber optics cable and also connectors to be used with these cables were early recognized as potential problem areas in the application of fiber optics because of the precision alignment required in order to keep losses low. Communications engineers have long recognized the weaknesses of mechanical connectors as being a limiting factor in the reliability of a system. With the very high precision required in order to maintain low losses for optical fiber communications cables, it was only natural that this would be quickly recognized as a potential problem area in fiber optics.

Single fiber splices and connections are dependent on the preparation of the ends of the fiber. This preparation involves removing the jacketing and other cabling materials from the end of the fiber, scoring the fiber and breaking it under tension. Some procedures also allow for polishing the end surface. Alignment of the fibers is critical, and must be within approximately 5 percent of the core diameter to achieve losses of a half-dB. V-grooves in an alignment device are a common method of providing the required alignment. After alignment, a drop of refractive index-matching adhesive secures the joint. A related technique uses a square tube. The tube is filled with index-matching epoxy, the fibers are inserted and butted in a corner with a slight bending pressure. Western Electric aligns the fibers with grooves similar to V-grooves (truncated V-grooves) etched into silicon chips (using photo mask techniques) designed especially for use with 12-fiber ribbons. This approach permits the stacking of 2 to 12 of the 12-fiber ribbons to achieve up to a 144-fiber connection. This produces a splice that has some of the advantages of a connector; i.e., it is relatively easy to disconnect and reconnect in the field. Other methods used for splicing single fibers include the use of thermal-shrinking tubes, or three alignment rods that touch tangentially. In a fusion or hot splice technique, fibers to be joined are heated with a flame, electric arc or other heater until softening and fusion occurs. In one fusion technique, surface tension between the fibers moves them to almost perfect alignment. Even the small single mode fibers can be field spliced using this method with losses less than 0.3 dB. Tensile-strength tests show that the average hot-spliced fiber's strength is about 60 percent of the original's, and that any breakage occurs some distance from the actual splice.

One drawback of the fusion technique is that an open flame is not usually employed in manholes, or other inclosed areas which may collect explosive gases. However, a large number of the commercial telephone applications discussed in section IV-1 "Commercial Uses," did employ the fusion method of splicing.

Connectors are a more difficult problem than splices. While splices have losses as low as 0.2 to 0.5 dB, connector losses will more likely be between 0.5 and 2 dB. This occurs primarily because of the difficulty in accomplishing the required alignment in a demountable, reproducible fashion. Many different

companies have used many different approaches to providing low loss connectors. One proposed method uses a double eccentric construction which allows the cores to be brought into very close alignment by rotating the different eccentric sections of the connector. Other approaches include a tapered plug method, which was used by AT T in their Chicago installation (see section IV) with an average loss of 0.5 dB. Another approach is a three rod approach where the rods overlap both fibers, thereby aligning their axes. Other approaches use four rods, or concentric sleeves, or overlapping resilient connector inserts. An approach used by AMP employs a resilient ferrule inside a bushing. The inside of the bushing is tapered, and as the cap is screwed on, the taper compresses the ferrule, moving the fiber on-center. This approach compensates for differences in fiber sizes.

From the above discussion, it is clear that although much work remains to be done in the area of splices and connectors, practical tools for splicing and successful designs of connectors of professional grade are available today. Cost reductions are still needed for many applications.

In addition to plain connectors, it should be pointed out that the different types of couplers used in microwave systems have their equivalents in optical fiber systems. Many of these are now commercially available. This includes a directional coupler, a Tee which allows a tap-off of energy, and a star which allows any incoming signal to be distributed to all other ports.

6. STATE OF THE ART

The state of the art in optical fibers is very difficult to summarize because there are such a large number of different types of cable presently available and because the technology is rapidly advancing.

For the window at 850 nm, one company offers fibers on 1100 meter reels with a maximum attenuation of 6 dB/km and minimum bandwidth of 200 MHz-km at \$0.30 per meter in quantities over 100 km, or \$0.35 per meter in quantities over 10 km. For a maximum attenuation of 3 dB/km and a minimum bandwidth of 600 MHz-km, the price is \$1.00 per meter in quantities over 100 km, or \$1.20 per meter in quantities over 10 km.

For double window fibers designed for both the 850 nm window and the 1300 nm window, a fiber with a maximum loss of 2.5 dB/km at 850 nm, 1.0 dB/km at 1300 nm, and a minimum bandwidth of 400 MHz-km is \$1.30 per meter in quantities over 100 km, or \$1.45 per meter in quantities over 10 km. Similar cable with a maximum attenuation of 3.5 dB/km at 850 nm, 2.0 dB at 1300 nm, and a minimum bandwidth of 400 MHz-km is \$0.35 per meter in quantities greater than 100 km or \$0.95 per meter in quantities greater than 10 km. These are some typical examples of the large numbers of combinations of attenuation and bandwidth available. As another example, another company offers a plastic clad silica fiber for use in economical, medium bandwidth, medium distance fiber data transmission systems, with 20 dB/km nominal attenuation at 790 nm and 30 ns/km dispersion for \$0.60 per meter. The same fiber in a single fiber heavy duty cable with Kevlar strength members and a polyethylene jacket with a 2.5 mm outside diameter is \$1.30 per meter with an additional service charge on orders less than \$500.00. This cable has a tensile strength of 45 knf, a minimum bend

radius of 2.5 cm, and weighs 6 kg/km. From this example, it can be observed that cabling can add considerably to the cost of a single fiber. Of course, the relative cost differential between basic fibers and cabled fibers is less for multifiber cables than for single fiber cables. As an example, a 7-fiber cable with a maximum loss of 20 dB/km nominal attenuation at 790 nm, and 30 ns/km dispersion, is priced at \$4.60 per meter. The fibers and cables discussed here are examples from currently available production cables.

One example of the state-of-the-art, on a laboratory systems basis, comes from experiments at the **Electrical** Communication Laboratories of NTT in Japan. Experimenters there have reported performance of digital optical fiber transmission systems operating in the 1200-1600 nm region using graded index fiber with repeater spacing of 52.6 km for 100-Mb/s transmission and 62.3 km for 32-Mb/s transmission. InGaAsP-InP laser diodes were used for transmission at 1295 nm; and as a photodetector, a Ge APD was used in a regenerative receiving panel. Using an LED transmitter at 1200 nm, the repeater spacing was reduced to 21.5 km, and an LED at 1500 nm gave a repeater spacing of 12.0 km.

Various companies have transmitting and receiving modules available for the 820 nm wavelength region, and have equipment under development for longer wavelengths. Connectors are available from a number of companies, as is splicing equipment for several types of splices. A portable fusion splicer from Siecor in a recent field installation of eight 8-fiber cables produced splices with a median insertion loss of 0.17 dB for 56 splices. Test equipment for use in developing and maintaining fiber optics communications is also available. A field proven Optical Time Domain Reflectometer is available. Its applications include: (1) determination of cable properties before and after installation or during a pulling or burying operation, (2) monitoring of field splicing and connector installation processes, and (3) maintenance testing and troubleshooting of installed cables.

Far ahead of most predictions, 5000 km of commercial fiber optics installations were operating at the end of 1977 in addition to less publicized government applications, and installations are currently being made at such a high rate that it would be difficult to determine the amount currently in use.

For a more complete understanding of the state of the art of fiber optical communications, careful reading of other sections of this report listed below will prove helpful:

- o III-2, Losses
- o III-3, Light Sources
- o III-4, Light Detectors
- o III-5, Splices and Connectors
- o IV-1, Commercial Uses.

Section IV-1, "Commercial Uses", is intended to provide the reader with some feel for the very rapid growth in application. In the author's opinion, this is very impressive, particularly when it is considered that only a portion of the actual commercial applications that are of interest are actually listed in that section.

IV. FIBER OPTICS APPLICATIONS

1. COMMERCIAL USES

This discussion begins with a few uses of fiber optics which might be of low present interest for DCS applications (although of possible future interest), and then progresses toward applications of more extensive current interest for the DCS.

There are two major types of fiber optics systems. One is used simply to ship visible light from one place to another. In some applications of this type, two light pipes are placed side-by-side; one is used to pump light to the location being observed or measured, and the other brings back the reflected light. Clusters of thousands of flexible fibers can permit the viewer to see (be provided an image of) an object that would otherwise be inaccessible, or that is located in a hazardous area. Numerous applications have developed in medicine and for industrial inspection in hazardous areas. A similar application of fiber bundles is to combine (superimpose) two different images. This combining operation, by means of line-by-line interlacing, provides a means for overlaying passive information (e.g., maps, grids, reticles) on generated (or real time) information (such as from a cathode ray tube). Another application is in photoelectric image intensifiers. There are numerous other applications of bundles of fibers such as signal detection or signal processing -- one such application is in optical character readers which convert printed information to electrical signals. Light guides are used in automobiles to provide light to instruments on the panel and thereby save lightbulbs and wire. In this application, heat is used to emboss a plastic ribbon that might be up to 30 ft long consisting of 10 or 20 fibers, and where embossed the ribbon emits light that illuminates the instruments.

The other type of fiber optics system, of primary interest in this report, is used to provide communications (where electrical signals are converted to invisible infrared light which is projected into the fiber for transmission to the other end where it is converted back to electrical signals). Even in this application there are two generally different areas of application. For shorter runs, such as within a building, the cable cost has to be low, but because in this application there are likely to be a large number of connectors separated by reasonably short cable runs, the cost of the connectors and electronics must also be much lower than for longer distance telecommunications. These shorter runs usually employ larger diameter fibers, frequently made from plastic rather than glass. Computers are expected to be users of short distance, high data rate communications with large quantities of fiber optics cable used between terminals and their associated computer. This will be particularly true where there is either a TEMPEST or an interference aspect to consider, or where the cable must run between two areas with a significant difference in ground potential (a power generator room, for example). Aircraft will use fiber optics for saving weight, which translates directly to fuel savings, and to minimize the effects of lightning strikes and interference on the pilot's digital control commands. The Union Pacific Railroad Company employs optical fiber cable in its closed circuit TV system used for remotely identifying freight cars at train

speeds up to 70 miles per hour. This permits them to avoid their previous problems from power surges and lightning current induced into the metallic cables.

The other telecommunications application of fiber optics is for longer distance communications where the use of large quantities of low-loss glass fiber (because of the long paths in addition to numerous locations) is likely to dramatically drive down the price of the fiber. This might eventually result in glass fiber virtually replacing plastics for nearly all telecommunications applications.

It appears that CATV will someday be a significant user of fiber optics since the medium is probably one of the most suitable for TV. There is considerable doubt that it has reached an economically competitive stage of development for most small present day CATV systems, even though some installations are presently used. Only where some of its other properties such as freedom from interference are considered important is fiber optics cable likely to be used widely for this purpose in the near future. Economically competitive applications of fiber optics to CATV include its use for very long distance transmission of digital CATV signals.

Communications between computers is another area of application of fiber optics where many of their properties can prove advantageous. At Keio University in Tokyo, an 0.6 mile run of optical fiber was chosen as a link between computers in order to avoid interference from a nearby 60 kV power line.

By far the largest quantities of optical fibers are expected to be used for telephone and related applications such as television, broadband facsimile, and switched data networks. Although cost savings will be the major reason for installing most of these fiber optics transmission facilities, other characteristics such as freedom from interference will also be important.

All published information about field trials of fiber optics transmission in telephone systems indicates an unqualified success. The Bell system field trial installation in Atlanta was placed into operation 13 June 1976 and 44.7 Mb/s signals were transmitted over the entire system. Although the total installed length was only 650 meters, many fibers were installed in the cable so that long paths could be obtained by looping through the cable many times. An 0.5 mW, 820nm GaAlAs laser supplied the signal which was detected by an APD receiver with a 4nW sensitivity. With allowances for cable loss, connector loss, and system margin, this gave a calculated spacing of 7 km between repeaters, but by using some of the lower loss fibers in the cable, it was possible to obtain error-free transmission over 10.9 km. This trial had all of the elements of an operational digital transmission system and generated confidence for the next trial in Chicago beginning 11 May 1977. Unlike the experimental Atlanta trial, the Chicago trial was selected to provide a range of actual customer services in a demanding downtown Chicago cable route. This test has proved so successful that the system has been placed in normal commercial operation. Also, a 2.5 mile fiber optics link was very successfully employed to carry television, data, and voice from the Olympic ice arena at Lake Placid, New York, to a central office and to a broadcast center.

Other companies have had similar successes. GTE has placed a fiber optics system in operation in Ft. Wayne, Indiana (for the General Telephone Company of Indiana). The particular 4.3 km route was selected because there was insufficient duct space for expansion using larger diameter copper cables. During testing, the error rate was better than 1×10^{-11} . The system is originally being used for 16 T1 lines (24 64 kB/s channels each), but more will be added as required by expansion. Another GTE installation is for the British Columbia Telephone Company in Burnaby, Canada. This is a 7.2 km test system and again the long term error rate was better than 1×10^{-11} , causing B.C. Telephone to become enthusiastic about installations for the near future. GTE has also placed a 7.4 km two-fiber system in an existing underground duct route between two switching centers in Vancouver. GTE also installed a cable between their Tampa Main Office and their West Side Office. Measurements on this cable showed losses of approximately 3.3 dB/km at 840 nm and 1.7 dB/km at 1060 nm.

The Harris Corporation has installed a 50 km underground T-4 interconnect from Calgary to Cheadle, Canada that is expected to ultimately carry up to 20,160 simultaneous calls.

In a rural application, a T-3 (a multiplex of 28 T-1's or 672 voice channels) fiber optics cable was installed by ITT for the Commonwealth Telephone Company between the communities of Wellsboro and Mansfield in North Central Pennsylvania. The 22 km installation consisted of 10 km of direct buried cable, 1 km placed in underground duct, 3 km lashed to existing cable, and 8 km lashed to 6 M steel messenger. The aerial cable consisted of five graded index fibers individually coated with Hytel polyester with Kevlar strength members and impregnated with a filling compound. This was jacketed with polyurethane, surrounded by 18 Kevlar yarns and another polyurethane jacket for a total outside diameter of .265 inch. This cable was adapted for underground by adding 12 mil aluminum tape and an extruded jacket of polyethylene to meet REA standards for copper cables. The outside diameter of the underground cable version is .370 inch. Basically the same construction methods were used as for conventional cables. Although it supports standard 45 Mb/s terminal equipment, the bit rate is actually 47 Mb/s to allow for parity bits used for in-service monitoring and testing.

New York Telephone Company is testing a fiber optics system for communications between computers. It will permit speeds of up to 44 Mb/s versus their present maximum rate of 50 kb/s, and its speed is eventually expected to increase to 274 Mb/s. It is expected to improve the current error rate of 10^{-4} to perhaps 10^{-11} .

The Hawaiian Telephone Company is committed to fiber optics to satisfy its need for new capacity to solve its rapid growth problem. Previous trials have proved the technology, and the fiber cable approach is more economical, partly because it either eliminates or minimizes the need to construct underground ducts along busy city thoroughfares. Their first permanent fiber optics system traverses a 1-kilometer route in existing ducts without the repeaters that would have been required in a coaxial cable system of equal (44.7 Mb/s) capacity. By the end of 1980, Hawaiian Telephone expects to have three T-3 systems (2016 voice channels) on the Kalihi/Waialeale route and three T-3 systems on the Punahoa/Waialeale route. Over the next 5 years, they will be constructing 33 T-3 systems.

The Continental Telephone Company of Virginia has placed an 8.1 km Woodbridge-Occoquan optical fiber cable system into operation. As in the Hawaiian installation, fusion splicing was used, and the cable completely removed the need for outside repeaters. If T1 carrier, which was the alternative, had been used, three outside repeater locations would have been required. For the DS-3 cross section (same number of channels as T-3 or 672 channels), which is 28 DS-1's, a total of 84 repeaters would be needed. The cable has six fibers with an average loss of 3.0 dB/km at 850 nm, but for when transmitter/receiver hardware for 1250 nm operation becomes available, a cable loss of about 1.3 dB/km has been measured. The average splice loss (60 splices) was 0.22 dB. Initially only four of the six fibers are being used with one DS-3 on each pair of fibers, and only 1000 circuits of the 1344 capacity is used, with the third pair of fibers used for a DS-3 protection channel. Provision is being made for wavelength division multiplexers to be added as required by future growth (planned for 1982) when four wavelengths separated from each other by 20 nanometers between 830 and 890 nanometers will be combined on each pair of fibers. End-to-end measurements on the installed system gave an error rate for DS-3 better than 10^{-11} at -51 dBm received power. In addition to this link, a link in Georgia of 3 miles is planned for service in August 1980. In Arkansas, two entrance links (3.2 km and 3.7 km respectively) for a digital radio hop will be implemented in 1981. In Missouri, routes of approximately 9 and 7 miles will be implemented in 1981. More than a dozen additional routes in Virginia are being considered for implementation between 1981 and 1984. All of the above have at least one DS-3 capacity. Those working on the above systems agreed that an optical fiber transmission system was a pleasure to plan, design, construct, operate and maintain.

One of the most forward-looking fiber optics projects is for the city of Higashi Ikoma, a suburb of Osaka, Japan, which is being extensively "wired" with optical fibers. It is called Hi-Ovis, for highly interactive optical visual information system; it provides a host of services ranging from local marriage announcements to a library of video programs. It provides each home subscriber with TV transmission of on-the-air programs, an interactive capability for the viewer to call up a still picture or a movie of their choice, and a dedicated neighborhood TV transmission. Maximum capacity of the experimental system is 168 subscribers; and 158 households now use the system. Each home has a camera, TV terminal controller, keyboard, and microphone. Consumers use the system for educational, leisure, news, and just plain social programming. About 11,000 splices are used in the fiber optics network that connects participants. Two fully equipped mobile studios cover community events, and computers are used to control information request and switching functions. The author has heard no report on its economic viability, but it can be expected to make a large contribution to worldwide communications innovations.

One of the largest and most extensive fiber optics telephone communications systems planned to date is a 611 mile AT&T system to link Washington, DC; Philadelphia, PA; New York, NY; and Boston, MA. When completed, the system will carry up to 80,000 simultaneous telephone calls, and ultimately will be used to transmit data and visual communications as well. The Washington to New York link is scheduled to begin operation in 1983, and the New York to Cambridge leg the following year. All but 97 miles of the 496 mile backbone system and 115 miles of metropolitan connecting links are to be placed in existing Bell System

underground conduit. The system will connect 19 No. 4 ESS switching offices in seven states and Washington, DC, each capable of handling up to 550,000 calls per hour. The cables containing 144 fibers are made by first assembling 12 fibers in a flat ribbon array and then depositing various layers of polyethylene and stainless steel about a stack of 12 of these ribbons. The resulting package is extremely durable and environmentally inert, thereby protecting the fibers from damage during installation and service. Splicing the 144 fiber cable will employ an array connector which uses etched silicon chips specially designed to align the fibers. Repeaters will be used once every 4 miles compared with about once a mile for some existing cable systems. It has been estimated that this project will save AT&T \$50 million in construction and operating costs by 1990.

Perhaps the longest fiber optics telecommunications network that has been planned thus far will be government-owned in Canada. Saskatchewan Telecommunications is beginning construction which will extend cable television to cities and large towns along a 3200 km route. Optical fibers will link the communities along the route and coaxial cable will be used for local distribution to homes within the cities and towns. The first 950 km will be laid in 1980 and 1981, 1000 km each in 1982 and 1983, and the remaining 250 km in 1984. The cable will consist of 12 fibers, of which 7 will be activated initially, one fiber for each digital video channel. Repeaters will be placed at up to 10 km intervals. The system is expected to eventually expand to connect some 350 of Saskatchewan Telecommunications' telephone switching centers into an all-digital, integrated telecommunications network providing a variety of services that could be in place by the year 2000.

Now that the feasibility of fiber optics communications on land has been proven, the world's first transoceanic fiber optics submarine cable could come as early as 1983. That cable, TAT-8, is being presented as one of seven possible options in U.S. cable and satellite plans for the 1986-1995 period. Another option calls for fiber optics cable in 1990 or 1992 while another option calls for beginning the replacement of the Intelsat V Communications satellite with a larger Intelsat VI series as early as 1986. Studies at Bell Telephone Laboratories have indicated that the cost for a transatlantic fiber optics submarine cable would be a fifth that of a projected copper coaxial cable system of the same capacity, and one-third the cost of today's undersea cable systems. In order to meet the system's 8 year mean time before failure requirement, each repeater will have an operating laser and three standbys, probably at 1300 nm unless the 1550 nm lasers develop fast enough. Speech interpolation, i.e., dynamic time sharing of the transmission capacity among the users to take advantage of pauses in speech, will be used and the bandwidth of the fiber optics cables will permit the planned system to carry 4,032 conversations per fiber compared with 200 for a copper coaxial cable. Furthermore the transmission will be higher in quality because the all-digital system will regenerate a nearly noise-free message at each repeater site. The low attenuation of the optical fibers will allow the expensive repeaters to be placed at least 35 km apart rather than 9 km spacing used for copper. In addition to saving money, the number of repeaters is important in achieving the 3-year system MFBF. Since the fiber cables are smaller and lighter than comparable coaxial cables, the cable-laying ships will not return for reloading as often. The system would have a projected life expectancy of 24 years, the same as the coaxial systems, and for the first time the cable will be capable of being easily branched into a Y configuration somewhere in the ocean.

The British Post Office has announced that work has started in Britain to lay one of the world's longest fiber optics telephone networks. The system, which was the subject of exhaustive evaluations in the UK for 3 years, will initially serve 15 routes over a total of 450 km. Links of 45 km are now being laid over two routes in the English midlands, and construction of a third route between the cities of London and Reading is about to begin. Installation of the network will occur between now and the end of 1982. The optical transmission system is considered to be a vital part of the conversion to digital telephone exchanges. The British Post Office has also laid what they believe to be the first operational submarine fiber optics link in the world, a 5 nautical mile loop of armored cable covered by 600 fathoms of water in Loch Fyne (Scotland).

A fiber optics field trial system (evaluation of expanded and new services) is being planned for Elie and neighboring St. Eustache in Manitoba, Canada, which has a low population density of 0.4 to 0.74 households per square kilometer. This system will provide each customer with access to nine TV channels, seven FM radio channels, and individual telephone (previously many were on multiparty lines) as well as a 56 kB/s data channel. A system for monitoring TV and data channel usage will be provided for research purposes. The trial system will be used for selective experiments with expanded and new services which will be influenced by the participants, and suppliers of the services, e.g., remote metering (utilities), alarm forwarding (security), load management (energy), broadband (TV), personal or business data. Since frost penetration ranges from four to six feet deep during the winter and most of the cable will be plowed to a depth up to 36 inches, the expansion and contraction of the soil will provide a severe test of the fiber optic cable.

Experimenters at the Electrical Communication Laboratories of NTT in Japan have reported performance of digital transmission systems operating in the 1200-1600 nm region using graded index fiber with repeater spacings of 52.6 km for 100 Mb/s transmission and 62.3 km for 32Mb/s transmission.

2. ADVANTAGES FOR MILITARY COMMUNICATIONS

No attempt will be made to list in order of importance the many characteristics of fiber optics cables which make them attractive as a transmission medium for military communications. Instead, most of these characteristics will be grouped according to the particular related physical properties of the fiber optics cables.

Several of the characteristics of optical fiber cable that make the technology attractive as a transmission medium for military communications result from electrical properties of the cable; i.e., it is a nonconductor of electricity. Some of them are listed below.

1. An optical fiber cable provides electrical isolation (even between high voltage points). Although it is a rather rare situation where communications circuits must connect to high voltage equipments, when it does occur, it can be difficult to handle. Where high voltage differentials between which communications must be provided are dc, the necessary isolation can usually be accomplished by using properly installed blocking capacitors or by using well shielded transformers in the communications system. If the high voltages that

must be isolated are not do, more complex filtering arrangements must be used in the communications system to provide the needed isolation. When metallic communications cables must be used between areas that have high voltage differences, a safety hazard to the personnel can also occur. The use of fiber optics communications cable can avoid these isolation and safety problems.

2. It is immune to signal or equipment degradation caused by electromagnetic pulses (EMP). A major entry path for electromagnetic pulses (EMP) into communications equipment is through the signal lines. Whereas effective techniques exist for protecting other lines into the equipment from EMP, the wide bandwidths of some signal lines make some of the techniques (such as those that are useful for power lines or control lines) much more difficult to apply. Long coaxial or twisted pair signal lines between widely separated locations can pick up large amounts of EMP energy. Since fiber optics communications cable is an electrical insulator, it has a natural immunity from EMP and requires no special consideration for this significant problem area except for those related to supplying power for repeaters.

3. It eliminates ground loops which can be a serious problem with metallic cables. Much effort, when using metallic cable, goes into assuring that appropriate and adequate shielding and bonding are accomplished, that appropriate grounding methods are selected, and that the grounds are properly located to avoid unwanted coupling between circuits or to any other source of noise. Much of this effort is unnecessary if the signal lines are insulators through which the undesired currents cannot flow, as in fiber optics communications cable. Fiber optics provides additional isolation because there can be no coupling between electrical currents and light pulse signals.

4. It is immune to short circuits. It is not overhead of for a technician to disconnect a metallic cable, thereby causing a short circuit which results in serious damage to the equipment. Equipments are usually designed to avoid this possibility, and technicians are usually careful where they place cables so that such an occurrence is rare. The use of fiber optics cable, an electrical insulator, prevents such occurrences.

5. It is not subject to degraded performance caused by sudden ionospheric disturbances resulting from solar activity. Occasionally newspapers report communications outages due to such disturbances. When this occurs in a circuit carried by a cable, it is probably due to the voltages or currents induced in the cable by the changes in the earth's magnetic field. Very long metallic cable runs can be particularly susceptible to these changing magnetic fields. Fiber optics cables are electrical insulators and the communications signals are carried by light rather than electrical currents. Such cables are not susceptible to degraded operation because of these sudden ionospheric disturbances.

6. It avoids problems of power surges and lightning induced currents. Lightning protection must be considered when metallic cables are used, and power surges can also cause problems when metallic cables are used. When the cable is an insulator, as in fiber optics communications cable, these problems do not occur.

7. It will not pick up electromagnetic interference. This particular characteristic was given as a major reason for selecting fiber optics for some already operating commercial applications. Electromagnetic interference can be a very serious problem. It is sometimes difficult to trace electromagnetic interference to its source; and whether or not it can be traced, it is sometimes difficult to eliminate interference from metallic cables. This can be particularly true with twisted pair since the cancellation due to the twisting and balance to ground is sometimes inadequate to control the problem, but it can also be true of coaxial cable when it has inadequate shielding. Since fiber optics communications cable is an insulator and electromagnetic interference cannot couple into the light beam, it is immune to this problem.

8. It does not radiate signals and has no emission problems. This is an important consideration from the standpoint of military security. It means that signal energy cannot be taken from the cable without tampering with the cable enough to at least reach the evanescent field in the cladding. This characteristic makes fiber optics cable a desirable transmission medium for use in a secure enclave. If any of the light penetrates the cladding, it will be absorbed in the covering materials.

9. It is free from crosstalk. Crosstalk is a rather common and annoying problem with many wire line systems. From the standpoint of military security it can be a source of undesirable information dispersal when the signals involved are not encrypted. Crosstalk can be controlled by using fiber optics systems because there is no optical coupling from one fiber to another within the cable, and there is no coupling from one channel to another between digital channels time division multiplexed on the same fiber. Of course, care must be taken in the design of the electronics used with the cable to be sure that crosstalk does not occur in the associated electronics.

10. Because the cable is nonmetallic, it can be hidden, e.g., underground or within the walls of a building, without the possibility of being located by metal detectors. This can be an important factor in the survivability of a communications cable. If the installation of the cable can be hidden or information about its installation misdirected, then once it is in operation, it will be very difficult to locate with techniques commonly used in the past.

11. It is free from sparking and cannot cause explosions.

12. Since fiber optics cable is nonmetallic, it does not provide a conducting path and therefore cannot attract lightning.

In addition to the many desirable characteristics listed above which are related to the electrical properties of the cable, there are a number of characteristics related to the physical properties of fiber optics cables which make them desirable as a transmission medium for military communications applications. Some of them are listed below.

1. Because of its small size compared with other types of communications cable, fiber optics cable requires less storage space.

2. Because fiber optics cable is small and light weight, it is more easily transported than other types of communications cable.

3. Deployment of fiber optics cables is usually simpler than metallic cables of equal capacity. This is because the fiber optics cable weighs much less and is smaller in diameter than metallic cables of equivalent capacity. Some of the fiber optics cables have a density very nearly the same as that of water. This helps for deployment in water.

4. For some circumstances, the fiber optics cable is much more rugged than coaxial or twisted pair cables. In a test sponsored by the Air Force, two-fiber and six-fiber ITT cables were laid across an asphalt driveway with a traffic counter. The cables were exposed to an average of 5000 cars and trucks per week during a 6-week summer test period. At the end of the test (after approximately 30,000 vehicles) all fibers within both the two-fiber and six-fiber ITT cables remained continuous.

In addition to the attractive electrical and mechanical properties of fiber optics cables, as listed above, a number of characteristics are related to the signal transmission properties of the cable which make fiber optics cable desirable for many military communications applications. Some of them are listed below.

1. Fiber optics cables have effective bandwidths that can be orders of magnitude greater than metallic cables. The two major limiting factors on the bandwidth of fiber optics cable are dispersion in the cable and bandwidth limitations in the transmitters and receivers. Because of dispersion, the bandwidths of fiber optics cables are inversely proportional to their lengths. If needed, the dispersion can be reduced by using graded index multimode fibers or single mode fibers.

2. The transmission characteristics of fiber optics cables are affected much less by the environment than metallic cables are (except for a strong ionizing radiation environment). Promising work is underway to reduce the increased losses that result from atomic radiation. This work is expected to reduce both the amount of permanent increase in losses, and the duration of temporary loss increase resulting from atomic radiation.

3. Losses in fiber optics cables are independent of bandwidth and it is unnecessary to reduce the system bandwidth in order to reduce losses. In coaxial or twisted pair cables the losses increase as the bandwidth increases. In fiber optic cables (within bandwidths presently considered for communications) the losses are independent of bandwidth and depend only on distance so that the familiar tradeoff between losses and bandwidth is not required.

4. Fewer repeaters are required for fiber optics communications than are required for metallic cables, because of the low losses of fiber optics cables which permit the repeaters to be placed much farther apart.

5. Fiber optics cables presently available permit the bandwidth of installed systems to be upgraded by replacing the transmitting and receiving electronics. In addition to increasing the speed of the transmitting and receiving electronics, the bandwidth transmitted by a cable can be increased by use of wavelength multiplexing, and in the case of double window fibers, by moving to the longer wavelength window (where dispersion is less) or by operating in both windows simultaneously.

6. Fiber optics cables, in common with other types of cables, require no frequency allocations and assignments from the crowded radio frequency spectrum which can cause serious problems when fielding radio communications systems.

7. Also, in common with other types of cables, fiber optics cables have no terrain clearance problems as encountered in microwave line-of-sight communications links.

In addition to the attractive characteristics resulting from electrical, mechanical, and signal transmission properties of the cable as discussed above, fiber optics communications has one additional attractive characteristic. It is a developing technology that is rapidly improving. Costs are rapidly dropping, losses are dropping, dispersion is improving, more optimum wavelengths are becoming available, reliability is improving, splicing methods and connectors are improving, etc. This characteristic, developing technology providing continuing improvement in the other desirable characteristics of fiber optics, has contributed to very rapid growth in commercial applications. Characteristics that make it attractive for commercial applications generally make it attractive for military applications also, but there are also some additional characteristics that make it attractive for military applications that are of little importance in commercial applications. These military applications include those related to survivability of military communications as discussed in a later section, and those related to TEMPEST problems.

Along with the above considerations of desirable characteristics, there are a number of areas that should be given additional work. These include: (1) transmitters and receivers, though economical and effective, need additional development to further bring down costs, move to the preferred frequency region, and further increase reliability; (2) existing fault location methods, though good, should have further refinement; (3) the precision required for splices and connectors seems to be under control, but still needs work to further reduce costs; (4) greatly increased signal losses (mostly temporary) caused by strong ionizing radiation need to be reduced, but work on this problem is progressing (material research is producing more tolerant cables, methods of using light beams to purge the light absorbing centers might prove effective, and it might be easier to shield a cable against this effect than against high energy electromagnetic pulses -- burying the cable provides a good shield from atomic radiation); (5) for linear system applications, the light sources and detectors, though presently effective, need to be made more linear; (6) efficiency of conversion from electrical signals to light and from light to electrical signals should be further improved; (7) methods of protecting the cables from sabotage and other unconventional warfare need to be developed; and (8) there are no national or international standards for fibers, connectors, or associated transmitters and receivers although standards are presently under development.

3. CURRENT MILITARY FIBER OPTICS SYSTEMS APPLICABLE TO THE U.S.

The Naval Ocean Systems Center (NOSC) has developed a series of fiber optics transmission systems: AN/FAC-1, AN/FAC-2, and AN/FAC-2A(V). These equipments are used to interconnect satellite earth terminals with associated technical control facilities. The unrepeated lengths of these interconnects range from 0.5 to 4.5 km. They use single fibers to pass digital non-return-to-zero (NRZ) data at rates to 20 MB/s. The operational sites are as listed below:

Site	No. of Channels	Reported** Failures	Total Op. Time (Hours)	Channel Hours	Channel Hours Between Failure
Ft. Meade	18	6	26,000	468,000	78,000
Wahiawa	30	4	17,000	510,000	129,000
Guam	18	2	13,000	234,000	117,000
Offutt AFB	8	0	10,000	80,000	80,000*
Hickam AFB	3	2	7,000	21,000	10,000
Ramstein AFB	3	0	6,000	18,000	18,000*
Norfolk	6	2	3,000	18,000	9,000

* To Date: no reported failures.

** Reported failures to date were primarily power supply, bypass capacitor and mechanical failure. The electro-optical components had only 3 failures.

Ft. Meade has an AN/FAC-1 System; Wahiawa, HI, and Guam have AN/FAC-2; and the remaining sites utilize the AN/FAC-2A(V) equipment. The AN/FAC-1 uses -48 Vdc power and a larger mechanical package than the AN/FAC-2 and AN/FAC-2A(V) which are powered from 115 Vac 50-400 Hz. The primary difference between the FAC-2 and the FAC-2A(V) is an upgraded interface board in the FAC-2A(V), which is a form, fit, and function replacement for the FAC-2 interface board.

The reasons for selection of the fiber optics systems over either microwave or coaxial systems are site dependent. The AN/FAC-1 equipment at Ft. Meade was selected because it was less expensive (2 km distance) than a microwave system, did not require frequency allocations and passed the 20 Mb/s information without the repeaters which would be required in a coaxial system.

The AN/FAC-2 system was selected over microwave for application at Wahiawa (2 km distance) for similar reasons and was selected over coax because the available telephone underground duct system was partially full and a new duct would be required if coax were used. Since the fiber cables to meet the requirement are smaller than the coax, these cables were installed in the partially full available duct system. The other sites used fiber optics for similar reasons in addition to the fact that the fiber cable does not radiate RF energy (TEMPEST) and is immune to EMP, and EMI, and does not require a complex grounding scheme to totally isolate the distant ends of the interconnect.

A Navy study was made to investigate opportunities for application of fiber optics in the DCA Digital European Backbone (DEB) Terrestrial Transmission Upgrade Project. Potential candidates were selected by applying five criteria or categories to the DEB plans:

- (a) Cable links planned for digital upgrade in the DEB.
- (b) Radio links with paths of 5 miles or less planned for Digital Radio and Multiplex Acquisition (DRAMA) digital upgrades.
- (c) Fixed satellite terminals with wideband data requirements.
- (d) DEB sites with local drops of wideband data.
- (e) DEB sites with significant equipment separations or expected noise problems.

Two DEB planned cable links that appeared technically well suited to fiber optics were found but host nation decisions appear to preclude its use. For the Boerfink-Muhl link, the host nation (Germany) will not identify the present cable routing or permit laying of new cable. Since the old cable is unsatisfactory for upgrade, a radio link must be installed. Of two DEB planned links to interconnect the DCS with SHAPE headquarters, one would be less than a kilometer long to a nearby DCS radio relay site so the fiber optics would not require repeaters. The proposed approach of implementing it with fiber optics had apparently been rejected by NATO with the decision to implement it with wire cable. However, this decision is still under consideration, and fiber optics might be used.

Three places were found with potential fiber optics applications for wideband data drops. It was found that the link from the Kamstein radio facility to the user had already been implemented with an AN/FAC-2A fiber optics link. Plans have already been made to lay a new fiber optics cable, and relocate one end of the AN/FAC-2A link when a new communications building is constructed at this location. A wideband data link from Naples to satellite terminals at Lago Di Patria is implemented with existing digital transmission equipment and has no need for fiber optics.

Possible requirements for wideband digital interconnects between DCS satellite and terrestrial radio facilities were examined at Lago Di Patria, Coltano, Lanostuhl, Berlin, Croughton, and Lajes. For one or more of the following reasons, no fiber optics needs were found: (a) wire cable is sufficient because of close proximity of satellite and terrestrial facilities, (b) low data rates are used which would not significantly benefit from fiber optics, or (c) facilities already installed will support future requirements.

A number of short path links are planned for DEB using DRAMA radio implementation. Although fiber optics is technically feasible for all of them, routing impediments exist because some are in politically unstable areas where physical security could be a problem, and in none of them is there an existing cable routing easement arrangement with the host nation and land owners.

No facilities were located where separation or noise problems would benefit from the application of fiber optics. A potential application at Hillingdon was eliminated by the decision to locate the radios in the main building next to their multiplexers rather than in the separate building next to the microwave antenna tower. During this investigation, several people commented that there were probably many installation problems encountered that could be easily resolved if "off-the-shelf" fiber optics equipment were readily available. However, these problems can generally be handled without it on a case by case basis.

Further investigation will be required before it is determined whether any of the above impediments to the application of fiber optics, in areas where they could be beneficial, could or should be removed.

Fiber optics cable is presently under consideration for improving DCS facilities in both Korea and Puerto Rico.

4. OTHER APPLICATIONS OF OPTICS IN COMMUNICATIONS

In addition to being a useful medium for carrying communications signals, the field of optics promises to provide very powerful tools for real time signal processing, and optical fibers play a part in some of the operations performed. This ability to perform parallel, real time signal processing at wide bandwidths or high data rates can be expected to have enormous impact on some future systems.

One operation well suited to optical processing is correlation as used for such functions as signal acquisition, data retrieval, target classification, and target tracking.

A great amount of information is available in visual images, but the transmission and storage of a large number of images can require excessive amounts of bandwidth. The most severe limitation of presently used compression schemes is the extensive computation required. Optical processing shows promise of reducing the amount of time required to accomplish it. Such processing can employ such optical operations as Fourier transforms, Hadamard transforms, and various nonlinear operations.

Certain types of mathematical operations can be performed very efficiently by optical methods. A single lens can perform a two dimensional Fourier transformation (the two dimensional Fourier transform appears at the focal plane). Spatial filtering can be performed on the transformed image (by passing it through a slide with selected opaque and transparent areas), and another lens used to perform the inverse Fourier transform. The use of residue arithmetic makes optical performance of such standard mathematical operations as addition, subtraction, and multiplication practical because it does not require the carry function and operations can occur in parallel. Residue conversion, addition, subtraction, multiplication and reversion can be accomplished by "maps" that change the path of the light (location of a spot of light) according to the operation performed.

Acousto-optic cells can be used for the deflection and modulation of light. An acousto-optic deflector generally operates in the Bragg regime where the angle of deflection is a function of the wavelength of the light, the index of refraction of the medium, the acoustic-wave velocity, and the frequency of the acoustic wave. All frequencies contained in the acoustic wave are displayed simultaneously in the deflected light beam. Spectral analysis is one application of acousto-optics. If an acoustic cell is placed at the front focal plane of a lens, the RF power spectrum will be displayed as a light-intensity distribution at the back focal plane of the lens. For high speed electrical output, an array of optical fibers can be placed at this focal plane with the other end of each fiber terminating in an optical detector. Doubly diffracted light resulting from imaging the diffracted light from one signal onto another moving with respect to it provides a multiplication operation that can be used for a correlation or convolution function. Correlation or convolution is then obtained by collecting and focusing this light onto a photodetector to effect the integral operation for these functions. This is referred to as space-integrating processing. If the signal that was modulated in space by the first diffraction in the above process is modulated in time, a time integrating processor is obtained. Acousto-optic correlation can be used for ultra-high resolution spectral analysis. It can also be used for processing spread-spectrum signals, or for ambiguity function processing.

There are several ways that optical fibers can be used in conjunction with the above methods of signal processing. Optical fibers are a means for providing very precise time delays. Bundles of fibers can be used for mapping one particular light pattern into another corresponding pattern. There conceivably are many other similar applications.

V. SURVIVABILITY OF FIBER OPTICS COMMUNICATIONS IN MILITARY APPLICATIONS

The ability of the communications function to survive an attack upon all or portions of wartime military communications system, is a very important consideration. Major portions of modern military capability might be unable to function satisfactorily if not supported with adequate communications. For this reason the ability of the communications system to survive and continue to provide adequate communications despite an attack upon the system will be an increasingly important consideration in selecting from among various alternatives in fielding communications systems.

As with many communications system survivability considerations, much of the following discussion must be based on conjecture. Nobody knows the specific strategy that an enemy might use in attacking communications. Deception and surprise are important elements in modern warfare. For these reasons, the communications system should be designed to be as invulnerable as possible to any type of attack that an enemy might choose. How does fiber optics fit among other approaches in satisfying survivability requirements. Surely, many of the properties of fiber optics communications systems which make them attractive for military application also make them more survivable. They are virtually immune to any type of electromagnetic attack that could be effective against other approaches. Wire systems have varying degrees of susceptibility to various types of electromagnetically induced noise and interference. Radio systems are, at least to a degree, subject to intentional and unintentional signal jamming. Neither interference nor jamming affects fiber optics communications. Neither radio systems nor fiber optics cable systems can fully satisfy military survivability requirements, but they complement one another very well.

Where there is existing metallic cable, to simplify installation, fiber optics cable could be placed in the same conduit as the metallic cable. Plastic conduit which has been used with fiber optics cable prevents detection with metal detectors, and fiber optics cable can successfully be buried without a conduit. Although fiber optics cable is susceptible to high levels of ionizing radiation which (temporarily, at least) increases its attenuation (see previous section on losses), it is not subject to EMP and other forms of disruption that can be very serious in metallic cables, and burying the cable can provide excellent shielding from the ionizing radiation (e.g., neutrons, protons, xrays, gamma rays, electrons). Cable types which are more tolerant to radiation are under development. Experiments have shown that radiation-induced loss in optical fibers is generally less at long wavelengths, at least for certain types of fibers, than at the 0.82 micrometer region being used for most present day installations. However, the induced loss after a low or moderate radiation dose can still be several orders of magnitude greater than the intrinsic loss of less than 1 dB/km. Other experiments have shown that decay of radiation-induced attenuation can be enhanced, at least in some fibers at some wavelengths, by photobleaching. This photobleaching is accomplished by exposing the fiber to a strong light, either of some frequency not being used for the communications or by continuous white light from a tungsten lamp. The major wavelength band susceptible to photobleaching is near 0.63 micrometers, but in high OH content cores there was no effect at wavelengths longer than 0.9 micrometers. However,

more explicit studies at the longer wavelengths are needed. In low OH content cores, the photobleached band is centered at 0.76 micrometers and has a much greater width so that it can be inferred that photobleaching will be effective in decreasing the induced attenuation at 1.1 micrometers. Further studies are in progress. Where it is necessary to operate in a nuclear environment, the fiber optics cable can be shielded from radiation by burying it. For many types of fiber optics cable, the radiation induced attenuation decreases very rapidly after the exposure. The length of time required for communications to be restored depends upon the signal margin designed into the system. For systems to be operated in this environment, cable parameters, level of radiation exposure, and other factors need to be taken into account in determining signal margins.

When considering the susceptibility of fiber optics to radiation effects resulting from nuclear weapons bursts, it is also important to keep in mind the problems of conventional cables when exposed to a nuclear environment. Even if the receiving and transmitting terminals are located in a well shielded area, conventional cables can be destroyed by the large currents induced by the EMP from a nuclear burst unless extensive shielding techniques are utilized (which are generally not practical for long cables). All dielectric fiber optics links are immune to EMP effects if satisfactory repeaters and power supply for them are provided should repeaters be needed for a particular application. It appears that in general the survivability of fiber optics cable is as good as that of metallic cable under most circumstances, and better under EMP and some types of interference. Some commercial fiber optics cable installations have been made specifically to avoid interference experienced when metallic cables were used.

A comparison of the survivability of fiber optics cable with that of microwave radio is somewhat more difficult than a comparison with other types of cable because of the major differences in methods of deployment. Once installed, fiber optics communications are generally free of the signal fading, jamming, interception, and other common problems of radio communications. Microwave radio towers are surely susceptible targets for attack by artillery and aircraft since they are normally located on high ground and extend well above surrounding objects where they can easily be observed. Fiber optics cable is much more difficult to observe and is unobservable if it is buried. Also, buried cable is not as susceptible to attack by aircraft or artillery. However, it is not a point target, but a long slender line that can be attacked at many different points. It has been said that this long extended exposure makes it much more vulnerable to attack by small squads of men specifically trained for such an attack. Why couldn't these men attack the microwave tower just as well. It has been suggested that personnel could be assigned to guard and protect the microwave tower, but that this couldn't be done for a distributed target such as a cable. But the cable could be hidden and the tower cannot. It has been suggested that enemy observers could mark their maps when they observe cable being installed and therefore they would know where the cables are. This implies that we need some studies on methods of installing cable without it being obvious that such an installation is being made. For example, for installation through an open field or wooded area, a battle tank or personnel carrier could be modified to bury fiber optical cable as it slowly rolls along. The modification could be made in such a way as not to be visible from more than

a couple of feet away from the tanks. Use of such a vehicle to bury the cable while accompanied by a few other tanks and some infantrymen could make the whole operation look like a training exercise. No-one would know a fiber optics cable had been laid. A little thought will bring forth a number of other ways that cable laying could be disguised. Further, just because the location of a cable is known doesn't mean that a squad of men can get to it undetected and easily destroy it. For example, suppose the cable is buried beneath the center of a concrete highway when the highway is built. It would be very difficult to get to it undetected because people would be using the highway, and getting through a foot of concrete would be no simple task. Hence, the normal concrete that would be used to support cars and trucks would also provide protection to the fiber optics cable while the users of the highway would provide observation of unusual activity along the highway, thus discouraging intruders from making such an attack. Some other potential locations for fiber optics communications cables include the pipes used to provide many different types of services. We have water pipes to carry water to users throughout the nation, and in most of the areas where our armed forces are deployed. We have sewer pipes to carry wastes away from these locations. We have gas pipes to carry energy from its sources to locations where it is needed. All of these are potential locations for fiber optics communications cable. Since fiber optics cable, at least single fiber cable, can be made very small, there is a very good possibility that it could be installed secretly in existing pipes without disturbing the normal function of the pipes. Since fiber optics cables are impervious to water and most other materials normally found in these pipes, they could coexist with each performing its normal function quite well over an extended period of time. Of course, for very long runs, repeaters would be required. Methods of providing these externally to the pipes could be developed along with methods of supplying power to them.

Another location that might be attractive for fiber optics cable installation is along stream beds. The fiber optics cable can withstand the wet environment without significant degradation. If buried below the stream bed, these cables would probably be relatively safe from damage. It should be possible to build boats to install such cable in a way that would conceal the cable laying activity. Again, for long cable runs repeaters would be needed, but this should not be an insurmountable problem.

There are many possibilities for making effective installations of fiber optics cables that would provide a significant enhancement of communications system survivability. Before writing off fiber optics cable as having possible survivability difficulties, these many possibilities should be investigated to determine their effectiveness. In those cases where possible survivability problems are found, methods of removing those problems should be evaluated. Since it is a new art, such studies have not been made. Further studies should be made to determine the tools required to make survivable fiber optics communications installations that are cost effective. Low cost equipment for drilling under buildings, highways, and other manmade objects for installing the cable should be investigated. Methods for burying the cable in difficult areas such as rock formations should also be investigated.

Of equal importance to permanent and semipermanent installations are the temporary facilities used for reconstitution of communications capability following an enemy attack on the communications system. Properties of fiber optics cable, such as being small, rugged, light weight and relatively low cost, will permit rapid deployment from aircraft for reconstitution of communications capability destroyed by the enemy. A small fiber optics cable lying in the tree tops or along the surface of other types of terrain is likely to be less obvious to enemy patrols and observers, and attract less attention than microwave towers standing above the tree tops on high ground. Over short distances, the fiber optics cable used for temporary reconstitution of communications could be deployed from manpacks. A squad of men on foot with proper splicing equipment and some battery operated repeaters could span relatively large distances, but this would require considerably more time than deployment of both cable and repeaters from aircraft or other types of vehicles. Of course, skilled crews should be utilized in making such installation, whenever possible, to be sure that the fibers are not subjected to unnecessary loss through careless or unskilled installation.

Another method of deploying single fiber or dual fiber optical cable for reconstitution of communications is with the use of rockets. Rocket-propelled missiles have been developed which deploy optical fiber behind them during flight for use in guiding the missile to its target. In this application, the fiber optics cable is used during missile flight to provide a television picture from a camera located in the missile. Since fiber optics cable has been successfully tested in this application, a similar approach without the warhead could be used to deploy a fiber optics cable over short distances for temporary communications reconstitution. Fiber optics cable is immune from the problems of terrain clearance experienced in reconstitution using microwave radio communications. When using fiber optics cable, there is no problem with frequency assignments; and the problem of interference, either intentional or unintentional, experienced with radio communications is nonexistent. However, good judgement in selecting the specific path and method of installing fiber optics cable used for temporary reconstitution of communications can be important to its survivability.

Another survivability consideration in which fiber optics communications might prove to be valuable relates to reducing the vulnerability of microwave radio towers to attacks by artillery or aircraft. Such towers located on high hills and towering above tree tops are easily spotted from aircraft or by ground observers, and they can be readily destroyed by artillery or aircraft. In order to reduce their vulnerability to this type of attack, the communications equipment on or in the towers could be limited to antennas, power amplifiers for the transmitters, low noise amplifiers and converters for the receivers, and a fiber optics terminal for the link to the rest of the communications equipment located remotely from the tower. All personnel and all of the rest of the communications equipment, i.e., power supplies; multiplexers; switching equipment; signal generating portions of transmitters; i.f., video and data sections of receivers, could be located in a camouflaged and/or protected area located a safe distance from the tower itself. Power cables to the transmitters and receivers and fiber optics cables for the communications and control signals would be the only connections required between the tower and the remotely

VI. CONCLUSIONS AND RECOMMENDATIONS

Fiber Optics Communications has already reached a stage of development where it has economic advantages over other alternatives for many communications installations. The technology is well in hand. Problems have been faced, and in most cases they have been solved. Remaining problems can generally be accommodated in any specific application, and promising approaches for completely solving them are being investigated. Optical cables have already made giant steps toward overcoming problems associated with other types of cables, and they are being selected as an alternative to other types of cable at a rapidly increasing rate. All reports relative to commercial (civil) telephone applications to date show a very enthusiastic, favorable assessment of the results. System designers enjoy working with fiber optics cable systems, and they are always pleased with how smoothly the installation proceeds and how well the system functions when the installation is completed.

For military applications, these cables have many desirable properties such as their small size, light weight, low losses, broad bandwidths, and freedom from interference. Many of these properties are listed earlier in this report and not repeated here. The one major negative property for military applications of fiber optics cable is the darkening of the fibers in a nuclear radiation environment. Although this is a very serious problem that must be kept in mind by system designers, installers, and users, it is not overwhelming. Fiber optics will be the best choice for a large number of cable applications. At present, this problem is probably best overcome by shielding the fibers from the radiation or by providing adequate signal margins to accommodate the additional loss (mostly temporary -- gradually recovering with time) caused by the atomic radiation. The required shielding from atomic radiation can be accomplished by burying the cable. (It should be kept in mind that photodiodes used as light detectors also are subject to radiation effects, and considerations similar to those for the optical fiber apply to them.) The losses of fiber optics cable caused by atomic radiation are known to be material dependent, and it is hoped that ongoing studies will open the path to developing fibers which are hardened against nuclear radiation. Also, experiments have shown that optical bleaching, where a substantially increased amount of light is launched into the fiber following radiation darkening, can considerably enhance the recovery rate from the increased signal attenuation which follows exposure to atomic radiation. When considering susceptibility of fiber optics to these radiation effects, problems which might result from nuclear weapons bursts, it is also important to keep in mind the problems of conventional cables when exposed to the nuclear environment. Even if their associated receiving and transmitting terminals are located in a well shielded area, conventional cables can be destroyed by the large currents induced by the EMP from a nuclear burst unless extensive shielding techniques are utilized (which are generally not practical for long cables). All dielectric fiber cables used for fiber optics communications links are immune to EMP effects. It appears that, in general, the survivability of fiber optics cable is as good as that of metallic cable under most circumstances, and better than metallic cable under EMP and some types of interference.

Fiber optics communications are generally free of the signal fading, jamming, interception, and other common problems of radio communications. They require no frequency allocations. In the future, fiber optics should be considered as an alternative to radio communications when mobility is not required, the necessary easement arrangements can be made, the cable can be buried, and the risk of sabotage is not too great.

Whenever there is a need within the DCS to expand or extend cable service, or to replace existing cable, the special characteristics and rapidly declining costs of fiber optics cable, along with its rapidly increasing reliability, indicate that its use should be carefully considered for that application.

In addition to traditional applications of cables, the special properties of fiber optics cables should encourage their use in other military applications where the conventional types of cable are obviously unsatisfactory. There is evidence that fiber optics, if properly applied, could considerably enhance the survivability of the DCS. Studies are needed for the purpose of determining how fiber optics could best be employed for this purpose. Those studies should include a large number of things that are of great importance to military applications, but are of much less (perhaps sometimes trivial) importance in civilian applications. These studies might include obtaining satisfactory answers to the questions listed in the last paragraph of this section.

The list of questions given at the end of the last paragraph should not be taken as a list of problems related to the application of fiber optics in the DCS, but rather as opportunities that would not be available without fiber optics technology. The fiber optics technology has proven itself for civilian application, but military applications result in additional requirements not faced in civilian applications. Along with these unique military requirements, which must be satisfied in order to make the best use of fiber optics technology in the DCS, come a lot of unanswered questions for which the civilian community needs no answers. It is recommended that programs be initiated to answer these questions, and that plans be made to apply fiber optics technology to enhance the survivability of the DCS. At the same time, it is recommended that fiber optics be considered for all additions or modifications to the DCS for reducing costs and enhancing functional capability.

Fiber optics communication is a very rapidly growing technology that promises communications capabilities for the individual user which far exceed those ever considered in the past, and because of this, it is certain to have a very important place in defense communications.

The following list contains examples of questions that need to be answered:

- (1) How do you go about (i.e., what procedures should be followed) installing a fiber optics cable in a land controlled by a foreign government, either friendly or unfriendly?
- (2) Can such an installation be made in secrecy (concealed from the enemy) without creating serious problems?
- (3) If so, do the procedures required to accomplish this differ between peacetime and wartime?

(4) If it can be accomplished, how difficult would it be to develop wartime procedures?

(5) How difficult would it be to develop peacetime procedures?

(6) If it cannot be accomplished in secrecy, what other alternatives are available to reduce the possibility of sabotage?

(7) Which of these alternatives provide the best protection for the cable?

(8) How does the installation approach differ between lands controlled by friendly forces (governments) and those controlled by unfriendly forces (governments)?

(9) How difficult would it be to make arrangements to place a fiber optics cable under each new highway where a cable running the length of a concrete highway would be relatively well protected from many types of attack?

(10) How conveniently could fiber optics be installed in stream beds where the water in the stream would afford a certain amount of protection?

(11) How conveniently could fiber optics be installed in existing underground water pipes, sewer pipes, or pipes used to carry gas for an energy supply?

(12) What equipment is needed to make the installation as economical and as fast as possible?

(13) Is there a need to develop new equipment for the installation of fiber optic cable for military applications?

(14) If so, what types of equipment are needed?

(15) Is there a need to develop equipment that will economically permit a fiber optics cable to be installed so as to cross beneath a highway without disturbing the highway itself?

(16) Is such equipment practical to develop?

(17) Is there a need to develop equipment for economically installing fiber optics cable beneath buildings without disturbing the buildings?

(18) Is such equipment practical to develop?

(19) Are there other possibilities that should be investigated for the installation of permanent or semipermanent fiber optic transmission links?

(20) How should fiber optics communications links be installed to best assure minimum vulnerability to attack?

(21) What measures can be taken to protect a fiber optics cable installation?

(22) How can a capability best be developed for using a small rocket propelled missile for stringing fiber optics cable for temporary restoration/reconstitution of a communications link knocked out during hostilities?

(23) How can a capability best be developed for the using helicopters to install fiber optics cable for use in restoration/reconstitution of a communications link?

(24) How can manpack equipment and procedures best be developed for installation of fiber optics cable for use in restoration/reconstitution?

(25) What installation rules should be followed in deploying fiber optics cable from aircraft (for use in temporary reconstitution of a communications link) if such an installation is not to be susceptible to loss because of unwise installation choices?

(26) Are there any needed improvements to the mechanical properties of presently available fiber optics cables in order for them to be applied effectively for fast deployment of temporary communications reconstitution, and if so what are they?

(27) What are the best methods of providing power to fiber optics repeaters without running wires to them?

(28) How deep should fiber optics cable be buried to be adequately shielded from atomic radiation?

(29) What is the tradeoff between depth of the cable and required signal margin following an atomic event?

(30) What is the tradeoff between signal margin and the time required to recover useful communications following an atomic bomb blast?

(31) What is the tradeoff between cable depth and the time required to recover useful communications following an atomic bomb blast?

(32) How close would repeaters need to be placed if the cable was not buried in order to provide useful communications after a reasonable recovery time following an atomic bomb blast?

(33) Can optical bleaching be an effective tool for the DCS when under atomic attack?

(34) How should receivers for fiber optics communications be designed to provide the best compromise between operation in a normal environment and operation following exposure to nuclear radiation?

(35) How can receivers, transmitters, and power sources best be shielded from atomic radiation and still provide accessibility for servicing?

(36) What procedures and equipment should be developed for monitoring and maintaining military fiber optics communications links?

(37) What types of fiber optics cable can best serve each of many different types of application in the DCS?

(38) What criteria should be employed to determine where fiber optics communications should be applied in the DCS?

(39) What cost and performance advantages would result from accelerated application of fiber optics to the DCS?

The first 27 questions listed above are generally related to the installation of fiber optics cable. Most of the questions have particular bearing on military applications where survivability of communications following an enemy attack is of great importance. Questions 23-25 are directly concerned with the installation of fiber optics for rapid, temporary restoration/reconstitution of communications knocked out by an enemy. Since DCS facilities are normally installed by the military departments (Army, Navy, Air Force), the answers to these questions should be pursued by the engineering installation elements of those departments. Even questions to which the answers might seem obvious because of a reader's previous experience or his knowledge of existing cable installation equipment should be reviewed. This should be done because of major technological changes and very significant differences in both the properties and applications of different types of cable.

Questions 28 through 35 are related directly to the application and utility of fiber optics during and following exposure to a nuclear environment. Their answers should be pursued by the military departments with support from the Defense Nuclear Agency.

Question 36 relates to maintenance of the fiber optics communications system and should be pursued by the military departments which perform such maintenance.

Questions 37-39 are directly related to the application of fiber optics in the DCS and should be jointly pursued by DCA and the military departments. Satisfactory answers to these three questions are highly dependent on the answers to previously listed questions in addition to the future architecture and goals of the DCS.

DCA is planning survivability studies for which potential applications of fiber optics to DCS survivability enhancement of the DCS will be carefully evaluated, both from the standpoint of the current state-of-the-art, and that of the very rapid changes occurring in this technology.

August 1981

ADDENDUM

The initial text of this technical note was prepared during the summer of 1980. During the editing, review and coordination, fiber optics technology continued to advance rapidly. The author believes some additional information is of sufficient importance to call for this addendum. For example, on page 8 in the discussion of losses, it is stated, "An impurity that definitely causes losses in all types of fiber is the OH radical, sometimes referred to as 'water'." Manufacturers in both the U.S. and Japan have announced fibers in which the large attenuation peaks caused by OH ions are greatly reduced (nearly eliminated) by a "drying" process during manufacture. These fibers can be used over the entire range of wavelengths between 800 and 1600 nanometers with losses as low as 0.5 dB/km between 1.2 and 1.7 micrometers. One Japanese manufacturer has announced that by removing the hydroxyl radical OH absorption at 1.39 micrometers was reduced to about 0.1 dB/km. Therefore, the fiber glass cable is no longer the limiting factor in the use of many additional wavelengths, but laser diodes and photodetectors become limiting factors. Advances are occurring in these areas also. Back-illuminated InGaAs photodiodes having a spectral response extending from 1.0-1.6 micrometers promise to be both fast and sensitive. Advances are being made in the use of two quaternary compounds, GaInAsP and GaAlAsSb, for lasers, light-emitting diodes, and detectors. Using a gallium-arsenide laser, researchers at Bell Labs have produced picosecond pulses tunable between 770 and 890 nanometers. Several methods of providing wavelength division multiplexing with low insertion loss and acceptable levels of crosstalk are being developed so that the ability of fiber optic cable to carry a wide range of wavelengths can be utilized to increase cable capacity.

In the section of Fiber Optics Technology there is a discussion of dispersion which indicates that it is the limiting factor in determining the useful bandwidth of an optical fiber. Modal dispersion can be eliminated by using single-mode fiber, but that still leaves material dispersion most of which results from longer wavelengths traveling faster than shorter ones in the glass. Research has shown that a laser pulse traveling through an alkali metal vapor under certain conditions will have shorter wavelengths traveling faster than longer ones. The two effects should compensate one another. In experiments at IBM, a metal-vapor cell just 50 centimeters across exactly compensated for the dispersion in 300 meters of optical fiber. Multiple passes through such a cell could compensate for signals traveling through several kilometers of fiber optics cable.

In Japan a 100 km single-mode fiber with losses as low as 0.2 dB/km has been successfully fabricated. Hence, by employing coherent detection of the optical carrier to reduce the detection threshold, it seems possible to provide fiber optics systems with repeater spacing greater than 100 km.

The very small core size of single-mode fiber optics cable (usually between 2 and 10 micrometers) make it difficult to efficiently couple the light into the fiber. By melting a lens onto the end of a single-mode fiber, a West German company has reduced the loss in coupling the 1.3 micrometer output of a buried-heterostructure diode laser into the fiber to 1.5 decibels. The lensed design also assures that only one millionth of the input

laser light is reflected. This is important because laser action can be affected by the backscattered light. This lens coupler was part of a demonstration system in which one gigabit per second was transmitted through 25.3 kilometers of unrepeated single-mode fiber with a core diameter of 7 micrometers. It had a mean attenuation of 0.7 dB/km including six spliced joints.

Transmission of 32 digitized television signals at a combined rate of 2.24 gigabits per second was demonstrated at the Heinrich Hertz Institute in West Berlin over 5.5 kilometer single-mode fiber at 840 nanometers with a measured bit error rate better than 10^{-9} .

There may be an alternative to the use of repeaters in fiber optic cables. In experiments at the Max Plank Institute in Göttingen, the amplification of a signal propagating through a fiber by evanescent-field (see page 7) interaction has been demonstrated. It may be possible to extend the technique to permit in-line amplification of signals being transmitted through a fiber, but much additional work must be done before this will be practical.

Work on standards for fiber optics is continuing. In its seventh plenary assembly, the International Telegraph and Telephone Consultative Committee (CCITT) of the International Telecommunications Union (ITU) approved recommendation G.651 on fiber optic standards drafted by study Group XV. The text will be published in volume 3 of the CCITT Yellow Book. The characteristics of glass graded-index multimode fibers recommended by CCITT are: Core diameter of 50 micrometers \pm 6%; cladding diameter of 125 micrometers \pm 2%; concentricity error of less than 6%; cladding noncircularity less than 2.4%.

Relative to commercial applications, the last paragraph on page 21 of this report indicates that fiber optics submarine cable was being considered as one of seven options in U.S. plans for cable and satellite transoceanic communications. The FCC has approved both the INTELSAT VI satellite series and an optical-fiber submarine cable to meet the telecommunications needs of the North Atlantic region from 1985-95. An earliest available date of 1988 was acceptable.

British Telecom will install its last coaxial wire telephone trunks by 1984 at the latest, and will begin ordering upwards of 75 "standard" digital fiber optics trunks per year in the autumn of 1982. The telephone authority's goal is an all-digital trunk network by 1991.

At mountain rescue huts in the Bavarian mountains fiber optics links have replaced overhead copper cables which had been vulnerable to lightning strikes. The telephone lines are solar-powered because the cables carry no electrical power. Including a conductor in the cable would have defeated its main purpose of avoiding lightning strikes. Solar cells supply 16 watts to charge a battery which can provide operation for at least 100 hours even if the sun is completely obscured.

Relative to deployment of fiber optics cable, in tests conducted by the Army at Fort Campbell, Ky lightweight fiber optics cable has been unreeled from a helicopter at speeds up to 210 kilometers per hour.

This brief addendum showing recent progress in fiber optics technology indicates the difficulty of avoiding obsolescence in such a publication.

ACKNOWLEDGEMENT

Because of the extremely large number of sources of information on fiber optics used, and the methods used to combine similar information from many sources, it is impractical for the author to reference individual sources of information. The author is indebted to nearly every major supplier of fiber optics systems and fiber optics components for the large amounts of information that they freely supplied. The primary source of material on nuclear radiation effects was the symposium on "Fiber Optics in the Nuclear Environment" sponsored by DNA, 25-27 March 1980. Much information relative to military application was supplied by the Navy, and the Army and Air Force also provided information. A stack of documents many feet deep was obtained from the Defense Documentation Center, and although much of this material proved to be obsolete, some of it was used. Information from these many sources was blended with the author's previous knowledge in preparing this report, but only a small fraction (much less than one percent) of the material reviewed was actually used in the preparation of the report.

DISTRIBUTION LIST

STANDARD:

R100 - 2	R200 - 1
R102/R103/R103k - 1	R300 - 1
R102M - 1	R400 - 1
R102T - 9 (8 for stock)	R500 - 1
R104 - 1	R700 - 1
R110 - 1	R800 - 1
R123 - 1 (Library)	NCS-TS - 1
R124A - 1 (for Archives)	101A - 1
	312 - 1

R102T - 12 (Unclassified/Unlimited Distribution)

DCA-EUR - 2 (Defense Communications Agency European Area
ATTN: Library
APO New York 09131)

DCA-PAC - 3 (Commander
Defense Communications Agency Pacific Area
Wheeler AFB, HI 96854)

DCA SW PAC - 1 (Commander, DCA - Southwest Pacific Region
APO San Francisco 96274)

DCA NW PAC - 1 (Commander, DCA - Northwest Pacific Region
APO San Francisco 96328)

DCA Korea -1 (Chief, DCA - Korea Field Office
APO San Francisco 96301)

DCA-Okinawa - 1 (Chief, DCA - Okinawa Field Office
FPO Seattle 98773)

DCA-Guam - 1 (Chief, DCA - Guam Field Office
Box 141 NAVCAMS WESTPAC
FPO San Francisco 96630)

US NAV Shore EE PAC - 1 (U.S. Naval Shore Electronics Engineering
Activity Pacific, Box 130, ATTN: Code 420
Pearl Harbor, HI 96860)

1843 EE SQ - 1 (1843 EE Squadron, ATTN: EIEXM
Hickam AFB, HI 96853)

DCA FO ITALY -1 (DCA Field Office Italy, Box 166
AFSOUTH (NATO), FPO New York 09524)

USDCFO - 1 (Unclassified/Unlimited Distribution)
(Chief, USDCFO/US NATO
APO New York 09667)