

LEVEL <sup>5</sup> PS



MISCELLANEOUS PAPER SL-81-22 ✓

# STRUCTURAL STABILITY EVALUATION LEECH LAKE DAM

by

Carl E. Pace

Structures Laboratory  
U. S. Army Engineer Waterways Experiment Station  
P. O. Box 631, Vicksburg, Miss. 39180

September 1981

Final Report

Approved For Public Release; Distribution Unlimited

DTIC  
SELECTED  
SEP 30 1981



AD A104777

DTIC FILE COPY

Prepared for U. S. Army Engineer District, St. Paul  
St. Paul, Minnesota 55101

Under Intra-Army Order No. NCS-IA-78-75

810

Destroy this report when no longer needed. Do not return  
it to the originator.

The findings in this report are not to be construed as an official  
Department of the Army position unless so designated  
by other authorized documents.

The contents of this report are not to be used for  
advertising, publication, or promotional purposes.  
Citation of trade names does not constitute an  
official endorsement or approval of the use of  
such commercial products.

Unclassified

AD-ALC 4777

SECURITY CLASSIFICATION OF THIS PAGE (When Data Entered)

REPORT DOCUMENTATION PAGE		READ INSTRUCTIONS BEFORE COMPLETING FORM
1. REPORT NUMBER Miscellaneous Paper SL-81-22	2. GOVT ACCESSION NO. AD-ALC 4777	3. RECIPIENT'S CATALOG NUMBER
4. TITLE (and Subtitle) STRUCTURAL STABILITY EVALUATION, LEECH LAKE DAM	5. TYPE OF REPORT & PERIOD COVERED Final Report	6. PERFORMING ORG. REPORT NUMBER
7. AUTHOR(s) Carl E. Pace	8. CONTRACT OR GRANT NUMBER(s) Intra-Army Order No. NCS-1A-78-75	9. PERFORMING ORGANIZATION NAME AND ADDRESS U. S. Army Engineer Waterways Experiment Station Structures Laboratory P. O. Box 631, Vicksburg, Miss. 39180
10. CONTROLLING OFFICE NAME AND ADDRESS U. S. Army Engineer District, St. Paul 1135 U. S. Post Office and Custom House St. Paul, Minn. 55101	11. REPORT DATE September 1981	12. PROGRAM ELEMENT, PROJECT, TASK AREA & WORK UNIT NUMBERS
13. MONITORING AGENCY NAME & ADDRESS (if different from Controlling Office)	14. NUMBER OF PAGES 70	15. SECURITY CLASS. (of this report) Unclassified
16. DISTRIBUTION STATEMENT (of this Report) Approved for public release; distribution unlimited.		
17. DISTRIBUTION STATEMENT (of the abstract entered in Block 20, if different from Report)		
18. SUPPLEMENTARY NOTES Available from National Technical Information Service, 5285 Port Royal Road, Springfield, Va. 22151		
19. KEY WORDS (Continue on reverse side if necessary and identify by block number) Concrete                      In situ testing              Repair Coring                          Piling                          Stability Dam                              Posttensioning              Testing Engineering condition survey      Pressuremeter              Uplift Foundation                      Rehabilitation		
20. ABSTRACT (Continue on reverse side if necessary and identify by block number) A stability analysis was conducted for a typical monolith of the Leech Lake Dam for the following load cases: (1) Normal Operation (2) Normal Operation with Truck Loading (H15-44) (3) Normal Operation with Earthquake (4) Normal Operation with Ice (5) High-Water Condition.  (Continued)		

DD FORM 1473

EDITION OF 1 NOV 65 IS OBSOLETE

Unclassified

SECURITY CLASSIFICATION OF THIS PAGE (When Data Entered)

422-122

Unclassified

SECURITY CLASSIFICATION OF THIS PAGE(When Data Entered)

20. ABSTRACT (Concluded)

A conventional stability analysis (rigid body assumptions) was conducted to determine the approximate magnitude of the loads acting on top of the piles supporting the monolith.

In order to obtain a detailed stability analysis of the complete monolith to resist the applied loads of the various case loadings, it was necessary to conduct in situ tests to determine the strength characteristics of the foundation material. For this purpose a Ménard pressuremeter was used to determine the in situ horizontal subgrade modulus.

The horizontal modulus of subgrade reaction was used in a three-dimensional direct stiffness analysis to determine the forces and deflections at the top of the foundation piles. A beam on an elastic foundation analysis was performed and the pressure, moment, and deflection along the length of the most critically loaded pile was determined.

The compressive forces, moments, and deflections predicted for the piles for all load cases were acceptable. However, the shear stresses and tensile forces in piles were predicted greater than allowable values; consequently, post-tensioning of the monoliths to the foundation will be one solution to correct these deficiencies. Therefore, it is recommended that a slant-hole, soil anchor system be used to induce compressive forces and to overcome the unfavorable tensile forces in certain piles, as well as to provide increased resistance to horizontal shearing forces.

From tests on cores, it was determined that the unconfined compressive strength (6800 psi average value) was adequate. The concrete in the interior of the structures appears sound; however, observable deteriorated concrete surfaces should be repaired.

After the slant-hole soil anchors are installed and the deteriorated concrete surfaces repaired, the useful life of the dam will be appreciably lengthened.

Unclassified

SECURITY CLASSIFICATION OF THIS PAGE(When Data Entered)

PREFACE

The evaluation of the stability of Leech Lake Dam was conducted for the U. S. Army Engineer District, St. Paul (NCS), by the Structures Laboratory (SL) of the U. S. Army Engineer Waterways Experiment Station (WES).

Authorization for this investigation was given in Intra-Army Order for Reimbursable Services No. NCS-1A-78-75, dated 23 July 1979.

The contract was monitored by personnel of NCS, with principal assistance from Messrs. Jerry Blomker and Roger Ronning. Their cooperation and assistance were greatly appreciated.

The study was performed under the direction of Messrs. Bryant Mather and William Flathau, Chief and Assistant Chief, respectively, SL; and John Scanlon, Chief of the Concrete Technology Division, SL. The structural stability analysis was performed by Dr. Carl Pace and Mr. Roy Campbell. The core logging and writing of the petrographic report was performed under the technical supervision of Mr. Alan Buck by Miss Barbara Pavlov and Mr. Sam Wong. The testing was performed by Mr. Mike Lloyd. The computer programming by Miss Alberta Wade was appreciated. The core drilling was under the direction of Mr. Mark Vispi, Geotechnical Laboratory, WES. Dr. Pace prepared the report.

Commanders and Directors during the conduct of the program and preparation and publication of the report were COL John L. Cannon, CE, COL Nelson P. Conover, CE, and COL Tilford C. Creel, CE. Mr. F. R. Brown was Technical Director.

Accession For	
NIS	<input checked="" type="checkbox"/>
ET	<input type="checkbox"/>
Useful	<input type="checkbox"/>
Just	<input type="checkbox"/>
By	
Dist	
ANAL	
FILE	

1

PT

CONTENTS

	<u>Page</u>
PREFACE . . . . .	1
CONVERSION FACTORS, INCH-POUND TO METRIC (SI) UNITS OF MEASUREMENT. . . . .	3
PART I: INTRODUCTION . . . . .	4
Background. . . . .	4
Project Features and History. . . . .	5
Objective . . . . .	8
Scope . . . . .	8
PART II: CORING PROGRAM. . . . .	9
PART III: PETROGRAPHIC REPORT AND CORE LOGS. . . . .	11
Samples . . . . .	11
Test Procedures . . . . .	11
Results . . . . .	12
Discussion. . . . .	13
PART IV: FOUNDATION AND CONCRETE PROPERTIES. . . . .	14
In Situ Foundation Testing. . . . .	14
Pressuremeter Tests . . . . .	14
Pressuremeter Field Tests and Results . . . . .	15
Concrete and Piling . . . . .	18
PART V: STABILITY ANALYSIS . . . . .	20
Conventional Stability Analysis . . . . .	20
Pile Foundation Analysis Using In Situ Soil Foundation Properties. . . . .	21
Forces and Deflections of Individual Piles. . . . .	25
PART VI: CONCLUSIONS AND RECOMMENDATIONS . . . . .	28
Foundation. . . . .	28
Concrete. . . . .	28
REFERENCES. . . . .	29
FIGURES 1-51	
TABLES 1-9	

CONVERSION FACTORS, INCH-POUND TO METRIC (SI)  
UNITS OF MEASUREMENT

Inch-pound units of measurement used in this report can be converted to metric (SI) units as follows:

<u>Multiply</u>	<u>By</u>	<u>To Obtain</u>
acre-feet	1233.489	cubic metres
cubic feet per second	0.02831685	cubic metres per second
cubic inches	0.00001638706	cubic metres
feet <sup>4</sup> (second moment of area)	0.0086309	metres to the fourth power
feet	0.3048	metres
inches	0.0254	metres
inches per pound (force)	0.00571015	metres per newton
kips (force)	4448.222	newtons
kip-feet	1355.818	newton-metre
kips (force) per square foot	47.88026	kilopascals
miles (U. S. statute)	1609.344	metres
pounds (force)	4.448222	newtons
pounds (mass)	0.4535924	kilograms
pounds (force) per square inch	6.894757	kilopascals
pounds (force) per inch	175.1268	newtons per metre
square miles (U. S. statute)	2.589988	square kilometres

## STRUCTURAL STABILITY EVALUATION

### LEECH LAKE DAM

#### PART I: INTRODUCTION

##### Background

1. The Mississippi River Headwaters Reservoir (Figure 1) system is one of the oldest projects in the U. S. Army Engineer District, St. Paul. The initial surveys and investigations were begun in 1867, at a time when the country was being opened up for development and settlement. The projects are old and were designed almost completely on site. Based on the available data, it appears that the original construction was almost entirely a practical field application in engineering with only basic theory to rely on. The physical design was performed in the field with a minimum of documentation. Documentation prior to construction was limited to the amount required to develop the engineering feasibility and requirements for construction, authorization, and funding. Post-construction documentation was generally limited to reporting quantities, costs, and justification for additional work or study. Construction data since 1915 generally amount to repair or rehabilitation of existing structures. The data are available, but generally are limited to construction drawings, with little theoretical data.

2. Leech Lake Reservoir (Figures 2 and 3) is one of six Federal reservoirs located in the headwaters region of the Mississippi River, about 200 miles<sup>\*</sup> northwest of Minneapolis, Minn., and 120 miles west of Duluth, Minn. The dam is located on Leech Lake River about 27 river miles above its junction with the Mississippi River. Views of Leech Lake Dam are presented in Figures 4 and 5.

3. The reservoir controls the runoff from a 1163 square mile drainage area and encompasses about 14 natural lakes, including Leech,

---

\* A table of factors for converting inch-pound units of measurement to metric (SI) units is presented on page 3.

Steamboat, Little Steamboat, Boy, Portage, Lomish, Swift, Three, Sucker, Swamp, Kabekona, Benedict, Horseshoe, and Garfield Lakes. At the present minimum operating stage of 0.0 ft the reservoir, including all of the affected lakes, has an area of approximately 167 square miles. At the maximum stage of 5.24 ft, the area is approximately 250.9 square miles.

4. The headwaters reservoirs were authorized by the River and Harbor Act of 1880 to provide supplemental flow during periods of low flow in the interest of navigation on the Mississippi River, at and below the Twin Cities. With the canalization of the Mississippi River below Minneapolis, Minn., the demands for storage releases from the reservoir system for navigation have been greatly reduced. Thus, in recent years the reservoirs have been operated primarily for other purposes, including flood control, recreation, fish and wildlife conservation, water supply, water quality improvement, and other related areas. Table 1 presents general reservoir data, and Table 2 presents pertinent dam data.

#### Project Features and History

5. Principally, Leech Lake Dam consists of a 294-ft-wide control structure and a 3314-ft-long earth embankment with a minimum height of 15 ft. The control structure has a concrete superstructure and aprons on a timber bearing pile and sheet-pile substructure. There are 26 bays having a combined spillway opening of 162 ft. There are 21 stoplog bays, while the other 5 bays are fitted with 48- by 48-in. cast iron slide gates. There is no stilling basin, but a reinforced concrete apron extends 39 ft downstream from the structure. The original dam was constructed in 1883, with subsequent reconstruction between 1900 and 1903. Substantial changes have been made over the years, with major modifications in 1895, 1912, 1924, 1929, 1934, 1957, and 1969.

6. The original construction consisted of a 1000-ft-long timber-crib structure on a timber-pile substructure, and a 2600-ft-long earth-fill section having a timber crib filled with select material at its

center. A 405-ft section of this structure was replaced by an earth fill in 1895. Between 1900 and 1903 the abutments and piers were reconstructed using concrete because of massive deterioration of the timber above the waterline. The timber apron was replaced by a concrete apron in 1957. Extensive changes due to a cofferdam failure during the 1957 apron replacement resulted in the loss of a portion of the structure (Figure 6). This necessitated the replacement of 14 piers and the left abutment with an earth-fill section and a new reinforced concrete left abutment with a timber-pile footing. Slide gates were installed in five gate bays in 1969 to facilitate operation of the dam. Also, many minor modifications and other work affecting the structure were required over the years.

#### Structure failure and repair

7. In 1957 a contract was awarded for apron replacement, but because of a construction cofferdam failure, which necessitated the removal of part of the structure and required extensive revisions and redesign, only a portion of the structure was constructed according to the basic plan.

8. The cofferdam failure occurred when a faulty, unapproved cofferdam plan used by the contractor resulted in failure of the sheet-pile cofferdam at pier 26 during dewatering. The cofferdam failure initiated a series of events that resulted in the failure (Figure 6) of the structure between pier 27 and the north abutment. A breach over 100 ft wide, with scour to a depth of about 20 ft occurred, toppling piers 28 through 38 into the scour hole and causing the loss of the pool. The contract work was allowed to continue in the undamaged portion of the structure. The area between the right abutment and pier 21 was completed according to the basic plan with minor modifications.

9. The area of failure beyond pier 25 was redesigned, and a new reinforced concrete T-wall abutment was constructed in the approximate location of pier 26. The old left abutment and pier 39 were removed, and an earth fill was used to replace the lost portion of structure. New steel sheet pile was driven 10 ft upstream from center line to el 1256. All unsuitable materials were removed from the scour hole prior

to backfilling. The backfill consisted of an impervious sandy clay section having a bottom width of 14 ft at the sheet-pile cutoff. The backfill was keyed 2 ft into the clay foundation material to insure an impervious seal. The new embankment fill section was brought up to a minimum top elevation of 1303.14\* with a top width of 28 ft, and has 1 V on 2-1/2 H side slopes.

Previous foundation corings

10. Borings taken prior to and after the 1957 apron replacement furnished considerable data on foundation conditions in the area of the control structure. A total of 20 auger and borings were taken. Borings were 20-30 ft deep. These borings indicate an extremely variable material, being sandy, silty, or peaty material, underlain by a clay or gravelly clay. Since the area is basically of fluvial or glaciofluvial origin, the composition of the material may be clean or mixed. There are areas having a fine, clean sand of high permeability. Lenses of gravel with material up to 1-1/2-in. size were recorded in the boring logs. Some areas of fat clays were found in thicknesses of up to 5 ft. Moisture contents in the silts and clays varied between 10 and 30 percent with higher moisture contents where peat or highly organic soils were present. The clay material had liquid limits of about 30 and plastic limits of 15. However, two samples of fat clay gave liquid limits of about 55 and a plastic limit of 20. Standard blow counts were taken, with values of from 2 to 24 recorded in the sands and values of from 8 to 45 in the clays. Average values in the sand and clay were 15 and 25, respectively. Where the clay materials had sand and gravel, the blow counts increased to about 30. Extreme high values of 210 and 84 were recorded where coarse gravel was present in the clay.

11. More detailed information concerning the reservoir and dam can be found in reports by the U. S. Army Engineer District, St. Paul (1973 and 1977).

---

\* All elevations are referred to msl, 1929 adjustment.

### Objective

12. The objective of this study is to evaluate the stability of the concrete control structure.

### Scope

13. This study is limited to a structural stability evaluation of the concrete control structure with consideration given to foundation and concrete properties. To aid in this evaluation three cores were drilled through the roadway and piers into the foundation. The foundation material was tested in situ in order to determine its supporting capabilities. The cores and foundation material were examined, and the structural stability of the dam was evaluated. The stability analysis was performed in accordance with current Corps of Engineer criteria.

## PART II: CORING PROGRAM

14. Since Leech Lake Dam falls into the classification of a low-head dam, limited coring was performed to obtain properties of the concrete and to obtain access to the foundation material for in situ testing.

15. Three NX concrete cores were obtained (Part III). Typical views showing the coring setup are presented in Figure 7. The piers are numbered from left to right looking from upstream to downstream. The locations of the core holes in piers 5, 14, and 24 are presented in Figure 8. The core holes were drilled by using a truck-mounted drill rig to core through the roadway and pier.

16. Diamond core bits and 5-ft-long double-tube, swivel-head core barrels were used to obtain cores from the concrete. All pressuremeter tests in core hole L-P5 and tests 2 and 3 in core hole L-P24 were performed by inserting the pressuremeter probe in the core hole to the desired elevation. The slotted casing was used for pressuremeter tests in core hole L-P14 and test 1 of L-P24 to house the pressuremeter probe as the casing was driven to the desired depth for pressuremeter tests.

17. The coring program was oriented toward determining:

- a. Depth of deteriorated concrete,
- b. Uniformity of concrete with depth,
- c. Unconfined compressive strength of the concrete, and
- d. Properties of the foundation by in situ testing using the core hole as an access to the foundation.

18. The in situ strength of the foundation material is an important factor in the analysis of the stability of the dam, which is supported on timber piles embedded in the foundation material. The drill rig was used in performing pressuremeter tests, standard penetration tests, and to obtain disturbed samples of the foundation material.

19. The coring program was considered a minimum for obtaining representative information on the concrete and foundation material but was adequate for this particular dam. The core holes were not grouted;

capped pipes were used to seal the top openings in order that in the future the core holes could be used for obtaining piezometric data. A view of a core and cut section is presented in Figure 9. The concrete at Leech Lake Dam is uniform except for some of the surface concrete, which is frost damaged.

PART III: PETROGRAPHIC REPORT AND CORE LOGS

Samples

20. Three NX size concrete cores were transported from Leech Lake Dam to the U. S. Army Engineer Waterways Experiment Station, Structures Laboratory, for tests and examination. They were received on 29 October 1979. The concrete in Leech Lake Dam is about 78 years old. Below is a listing and description of the cores. All cores were drilled vertically.

<u>Core No.</u>	<u>Location</u>	<u>Elev. (ft)</u>	<u>Depth (ft)</u>
L-P5	Pier 5	1302.74	17.4
L-P14	Pier 14	1302.74	17.3
L-P24	Pier 24	1302.74	16.8

Test Procedures

21. All three cores were logged in the laboratory, and samples were selected that represented typical material from each core. Further tests and examinations were made on these selected pieces. An unconfined compressive strength test was made on a piece of concrete from the top, middle, and bottom portion of each core.

22. Six inches of concrete from core L-P5 and from core L-P24 were sawed longitudinally. The piece from L-P5 was from the 5.5-ft depth, while the piece from L-P24 was from the 11.5-ft depth. One sawed surface from each piece was ground smooth and then examined using a stereomicroscope. Fresh fracture surfaces on pieces from each core were also examined using a stereomicroscope.

23. A cement paste concentrate was prepared from the upper portion (about 1.3 ft) of core L-P24. This was done by crushing fragments of the core and passing the material over a 150- $\mu$ m (No. 100) sieve. The material passing this sieve was considered to be a cement paste concentrate. The paste concentrate was then ground to pass a 45- $\mu$ m (No. 325)

sieve and examined by X-ray diffraction. The X-ray pattern was made with an X-ray diffractometer using nickel-filtered copper radiation.

### Results

24. The sequence of different materials from the top downward in each core was as follows: bridge deck concrete overlay (0.63 to 0.75 ft thick), steel bearing plate (0.04 to 0.06 ft thick), pier concrete, wood, and mortar. The materials in each core are shown in Figures 10, 11, and 12.

25. The composition of the overlay concrete in the bridge deck was different from the concrete in the piers. The overlay concrete had a 1/2- to 1-in.-max size aggregate consisting of a crushed gravel. The aggregate was composed primarily of quartzose sandstone, with lesser amounts of limestone, quartzite, siltstone, and occasional pieces of granite.

26. The underlying concrete making up the piers contained a larger and different aggregate ranging from 1 to 2 in. in maximum size. This aggregate consisted of a crushed gravel aggregate mixture composed of granite, granite gneiss, and fine-grained, hard, igneous and metamorphic rocks. The fine aggregate was of the same material.

27. All of the concrete appeared well consolidated except for some slight honeycombing in the original concrete from pier No. 5 (Figure 10). None of the concrete was air entrained. The bridge deck concrete overlay was intact, but the near surface original underlying concrete in all of the cores was damaged, probably by frost action to a depth of approximately 1.5 ft.

28. Cores L-P5 and L-P14 each contained a near surface vertical fracture (Figures 10 and 11). This fracture in each of the cores was stained and ran to depths of 1.5 ft for L-P5 and 1.7 ft for L-P14.

29. Several cold joints (i.e., open contacts) were identified in each core (Figures 10, 11, and 12). The joints were located at approximately 1.5-ft and 3.5-ft depths.

30. White material recognized as alkali-silica reaction gel, or ettringite, or a mixture of the two, was present in some voids and coating some aggregate surfaces. Reaction rims indicative of alkali-silica reaction were also present on some aggregate particles. The silica gel was usually found on or near the granite and granite gneiss particles. This may indicate that these were the reactive constituents in the aggregate.

31. Mortar and wood found at the base of each core were in good condition (Figures 10, 11, and 12). The mortar was highly porous and composed of the same fine aggregate as that used to make the pier concrete.

32. X-ray diffraction showed the cement paste to be composed of calcium hydroxide, ettringite, calcite, and tetracalcium aluminate carbonate-11-hydrate, and hemihydrate-12-hydrate. The pattern also showed quartz, plagioclase and potassium feldspar, and mica from aggregate contamination of the cement paste sample.

#### Discussion

33. While most of the breaks in the concrete were probably due to the drilling operation, it is safe to assume that some or all of the fracturing shown in the upper foot or so of concrete, near the overlay contact, was due to frost damage (Figures 10, 11, and 12).

34. Although an alkali-silica reaction has occurred in the concrete, the condition of the concrete did not indicate that it had caused significant damage.

## PART IV: FOUNDATION AND CONCRETE PROPERTIES

### In Situ Foundation Testing

35. An estimation of the foundation supporting characteristics for a piling system that is based on material properties determined from the sampling of foundation materials, transporting and preparing the samples for testing, and testing the samples, is at best approximate. Soil conditions and stress fields can be controlled in the laboratory, but just how faithfully the laboratory tests results represent in situ conditions is a matter of conjecture. A further complication at Leech Lake Dam was that the foundation material contained a great deal of saturated sand and gravel which made the ability to obtain undisturbed samples doubtful.

36. Considering the above conditions, it was decided to test the foundation materials in situ by determining the resistance of the soil to horizontal deformation. Hence, in situ testing of the foundation material, which supports the piling, was accomplished to obtain the structural supporting characteristics of the pile-foundation system. The pressuremeter method was used to measure deformation properties and obtain a rupture, or limit, resistance of the foundation material.

### Pressuremeter Tests

37. In situ testing to determine the supporting characteristics of a foundation material for a pile substructure has been considered for many years. In 1933 Kögler wrote about such a pressuremeter which he had invented (Baguelin, Jiziquel, and Shields 1978). For over 15 years the pressuremeter has been used throughout France in the design of building and bridge foundations. Various types of pressuremeters are now being used in the United States; a self-boring pressuremeter shows great promise for future use.

38. In situ testing to determine the resistance of the soil to horizontal displacement is an ideal way to estimate the supporting capacity of material for a pile foundation.

39. The pressuremeter consists of two main components; a probe and a volumeter. The probe is composed of a cylindrical metal body. The center section is covered with a rubber membrane and then the whole metal body is covered by a radially deformable cover; thus, forming three independent cells. The central cell, or measuring cell, is filled with water under controlled pressure from the volumeter while the other two guard cells are inflated with a gas automatically maintained at a slightly lower pressure.

40. The volumeter is a fiberglass container with a front panel on which are fixed all the various regulators, pressure gages, valves, etc. The container houses the volumeter that supplies the central measuring cell. The volume variations during the tests are read on the sight tube. The range of the pressuremeter used was from 0 to 80 bars. The pressure was supplied by a compressed gas bottle.

41. The volumeter is connected to the probe by what appears to be a single, flexible plastic tube which, in fact, contains two coaxial tubes.

42. The probe was placed in a previously drilled borehole at the desired elevation; however, in certain cases, the probe was contained in a slotted tube that was driven to the desired test elevation.

43. Pressure was applied in equal increments and the corresponding volume variations noted at 15, 30, and 60 seconds. The data were corrected for calibration, water head, etc., and then used in an analysis to obtain the supporting capability for the pile foundation.

#### Pressuremeter Field Tests and Results

44. In order to test the material that supports the pile foundation under Leech Lake Dam, access to the foundation material had to be obtained. This was done by coring a NX hole through the dam piers and down to the foundation material. For core hole L-P5 and tests 2 and 3 of hole L-P24, a carefully sized hole was drilled, the pressuremeter probe was inserted to the desired elevation, and a test was performed.

The slotted casing was used to house the pressuremeter probe as the casing was driven to the desired depth for pressuremeter tests for hole L-P14 and test 1 of L-P24. A pressurized bottle of gas was used as the pressure source. The pressuremeter tests were performed at three elevations in each test hole.

45. The locations of the probe below the pier are presented in Table 3 for each test hole.

46. Standard penetration (split spoon) tests were performed in each test hole and the results are presented in Table 4.

47. Disturbed samples of the foundation material were obtained and transported to the U. S. Army Engineer Waterways Experiment Station, Structures Laboratory, for classification. The foundation material under Leech Lake Dam is made up of clay, silt, sand, and gravel (Figures 13-20). The standard penetration values for this material indicate that it is relatively loose, except for three tests near the foundation surface which were influenced by some surface condition such as grout or gravel.

48. The main characteristic of the foundation material, which indicates its supporting capability for a pile foundation, is the subgrade modulus and its variation with pressure and depth into the foundation. The pressuremeter tests were used to obtain this data. Plots of data for the holes are presented in Figures 21-41.

49. The recorded pressures must be corrected because of the hydrostatic pressure of water in the tubing and for the probe calibration, which gives the resistance to expansion of the rubber membrane. The corrected pressure curves are presented in Figures 21, 22, and 23 for hole L-P5, Figures 28, 29, and 30 for hole L-P14, and Figures 35, 36, and 37 for hole L-P24.

50. The limit pressure was obtained by plotting pressure versus  $\frac{1}{\text{volume}}$  and extrapolating the curves to the pressure at  $\frac{1}{\text{volume}} = 0$ . The limit pressure determinations for each test hole are presented in Figures 22, 29, and 36.

51. The shear modulus ( $G$ ) (Baguelin, Jiziquel, and Shields, 1978) depends not only on the slope of the pressure-volume curve but also on the volume of the probe. The average volume is used in calculating the shear modulus as follows:

$$G_M = \left[ 535 + \frac{V(I) + V(I+1)}{2} \right] \frac{\Delta p}{\Delta V} \quad (1)$$

$$= \left[ 535 + \frac{V(I) + V(I+1)}{2} \right] \left[ \frac{P(I+1) - P(I)}{V(I+1) - V(I)} \right]$$

52. The deformation modulus, which is something roughly equivalent to Young's modulus, is obtained from the well known relation:

$$G_M = \frac{E_p}{2(1 + \nu)} \quad (2)$$

53. Poisson's ratio is used as 0.33, and the resulting deformation modulus is called the Ménard modulus,  $E_M$ .

$$E_M = 2(1 + \nu)G_M \quad (3)$$

$$= 2(1 + 0.33)G_M = 2.66G_M$$

The Ménard modulus is presented in Figures 25, 32, and 39 for each test hole.

54. The subgrade modulus ( $k$ ) is obtained from the following equations:

$$\frac{1}{k} = \frac{2}{9E_M} \cdot B_o \left( \frac{B}{B_o} \times 2.65 \right)^\alpha + \frac{\alpha}{6E_M} \cdot B \quad (B > 2 \text{ ft}) \quad (4)$$

or

$$\frac{1}{k} = \frac{B}{E_M} \left( \frac{4(2.65)^\alpha + 3\alpha}{18} \right) \quad (B < 2 \text{ ft}) \quad (5)$$

where

$B_o$  = reference pile diameter, 2 ft

$B$  = pile diameter

$\alpha$  = rheological coefficient given in Figures 3-48 of Baguelin, Jiziquel, and Shields (1978).

55. After a representative value of  $k$  has been determined, it can be multiplied by the pile diameter to obtain the horizontal modulus of reaction for the pile-soil system. The horizontal modulus of reaction of the soil can be used in the piling analysis to obtain deflections, forces, and moments to use in evaluating the adequacy of the pile foundation.

#### Concrete and Piling

56. The 12-in.-diam Norway Pine pilings, which support the monoliths at Leech Lake Dam, are approximately 15 ft long. The properties of the Norway Pine are as follows:

Modulus of elasticity (E) =  $1.32 \times 10^6$  psi

Shear modulus (G) =  $0.45 \times 10^6$  psi

Allowable compressive stress parallel to grain = 1100 psi

Allowable tensile stress parallel to grain = 775 psi

Allowable average shear stress = 75 psi

Allowable compressive load on a pile = 124 kips

Allowable tensile load on a pile = 0 kips

Average allowable lateral load per pile = 8.5 kips

Allowable moment in a pile = 131,000 in.-lb or 10.9 kip-ft

The properties of Norway wood can be found in many handbooks. One such reference is presented (Southern Pine Association, 1954).

57. The unconfined compressive strength of the concrete is presented in Table 5. The compressive strengths are adequate, and since the interior concrete has performed so well for over 70 years, the structure, with some maintenance, can be expected to perform well for many more years.

58. Since the interior concrete is of good quality, the deteriorated surface concrete should be repaired to keep water from entering cracks and accelerating the deterioration of the interior concrete.

There are a number of methods of repair that might be used; but, the Upper Mississippi River Headwater Structures are ideal for an economical repair such as:

- a. Clean surface concrete
- b. Fill cracks
- c. Paint on a cementitious coating to rehabilitate the surface concrete.

This type repair can be performed rapidly and economically. It is analogous to cleaning, filling cracks, and painting a room in a house. Any local labor could do the work with only common tools.

59. Under some conditions an acrylic-polymer coating of such a composition as listed in Table 6 and Table 7 might be used. Certain acrylic polymers have exhibited good bond and noncracking characteristics when used in ordinary environments. They have also shown good resistance to freezing and thawing environments. The particular polymer to be used should be tested as follows before being used to rehabilitate the surface concrete of the Upper Mississippi River Headwater Structures:

- a. Determine the resistance of the coating to cracking during extreme temperature changes
- b. Determine its ability to retain bond capability in freezing and thawing environments, and
- c. Determine its ability to "breathe," thus allowing water to escape from the interior concrete through the coating, preventing critical saturation of the concrete.

## PART V: STABILITY ANALYSIS

### Conventional Stability Analysis

60. Conventional stability analysis assumes that the base of a structure is rigid in determining the loads on the piles. Conventional stability analysis also does not consider the load distribution due to pile and structure deformations with consideration being given to the strength and support characteristics of the soil on the piling system. The monoliths at Leech Lake Dam are of such size and shape that the assumption of a rigid base is adequate. The supporting characteristic of the soil and the deflection of the pile and soil is taken into account by using a modulus of subgrade reaction that is obtained from in situ testing of the foundation material (Part IV).

61. A schematic of a typical interior monolith at Leech Lake Dam is presented in Figure 42.

62. Five load cases as follows were analyzed.

- a. Normal operation
- b. Normal operation with truck loading (H15-44)
- c. Normal operation with earthquake
- d. Normal operation with ice
- e. High-water condition.

63. The applied loads and moments on the pile system are presented in Figures 43-48. The moment of inertia of the pile group is presented in Figure 49. A summary of the forces and moments on the piling system obtained by a conventional stability analysis is presented in Table 8. At this point, the adequacy of the pile foundation could not be evaluated because allowable vertical and horizontal loads based on the supporting capabilities of the foundation material must be known to judge the adequacy of the piles. These allowables were not known for Leech Lake Dam.

64. To determine the adequacy of the stability of the pile foundation, in situ testing was performed to determine the supporting characteristics of the foundation material. The variation of modulus of

subgrade reaction with depth and deformation was obtained. The modulus of subgrade reaction (Figures 27, 34, and 41) varies significantly, but a conservative modulus of  $1000 \frac{\text{psi}}{\text{in.}}$  was selected for consideration in the analysis. This value was decreased to  $540 \frac{\text{psi}}{\text{in.}}$  due to close pile spacing. The reduction factor was calculated by the following formula as suggested by Davisson (1970).

$$h_a = 0.15 \frac{a}{b} - 0.2 \quad (3 < \frac{a}{b} < 8)$$

where

$h_a$  = reduction factor

$a$  = center to center pile spacing from upstream to downstream

$B$  = pile diameter

65. If the piling layout is found to be adequate using this analysis, the entire dam can be considered adequate in stability.

66. The allowable loads on the piles were determined based on the material properties of the pile. The stability of the pile foundation was evaluated based on the deflections at the top of the pile. If the horizontal deflections of the top of the pile are found to be less than one-quarter inch, the piling system can be considered adequate.

#### Pile Foundation Analysis Using In Situ Soil Foundation Properties

67. A general direct stiffness analysis for a three-dimensional pile foundation was used as presented by Saul (1968), which expands the Hrennikoff (1950) method from two dimensions to three. The general solution using this stiffness analysis is presented below.

68. The forces on a single pile can be equated to the pile displacement by the expression

$$\{F\}_i = \{b\}_i \{X\}_i \quad (6)$$

The  $\{b\}_i$  values are the individual pile stiffness influence coefficients, called the elastic pile constants.

69. The positive coordinate system is as follows:

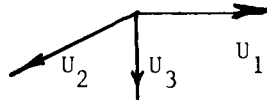

70. The  $\{b\}_i$  matrix for a three-dimensional system can be defined for the  $i^{\text{th}}$  pile as

$$\{b\}_i = \begin{bmatrix} b_{11} & 0 & 0 & 0 & b_{15} & 0 \\ 0 & b_{22} & 0 & b_{24} & 0 & 0 \\ 0 & 0 & b_{33} & 0 & 0 & 0 \\ 0 & b_{42} & 0 & b_{44} & 0 & 0 \\ b_{51} & 0 & 0 & 0 & b_{55} & 0 \\ 0 & 0 & 0 & 0 & 0 & b_{66} \end{bmatrix}$$

The elastic pile constants have meaning as follows:

- $b_{11}$  = the force required to displace the pile head a unit distance along the  $U_1$ -axis, FORCE/LENGTH.
- $b_{22}$  = the force required to displace the pile head a unit distance along the  $U_2$ -axis, FORCE/LENGTH.
- $b_{33}$  = the force required to displace the pile head a unit distance along the  $U_3$ -axis, FORCE/LENGTH.
- $b_{44}$  = the moment required to displace the pile head a unit rotation around the  $U_1$ -axis, FORCE-LENGTH/RADIAN.
- $b_{55}$  = the moment required to displace the pile head a unit rotation around the  $U_2$ -axis, FORCE-LENGTH/RADIAN.
- $b_{66}$  = the torque required to displace the pile head a unit rotation around the  $U_3$ -axis, FORCE/RADIAN.
- $b_{15}$  = the force along the  $U_1$ -axis caused by a unit rotation of the pile head around the  $U_2$ -axis, FORCE/RADIAN.
- $-b_{24}$  = the force along the  $U_2$ -axis caused by a unit rotation of the pile head around the  $U_1$ -axis, FORCE/RADIAN.  
(NOTE: The sign is negative.)
- $b_{51}$  = the moment around the  $U_2$ -axis caused by a unit of displacement of the pile head along the  $U_1$ -axis, FORCE-LENGTH/LENGTH.

$-b_{42}$  = the moment around the  $U_1$ -axis caused by a unit displacement of the pile head along the  $U_2$ -axis, FORCE-LENGTH/LENGTH.

71. Pile  $i$  may be located in the foundation with axis through its origin parallel to the foundation axis. The foundation loads  $\{Q\}$  and displacements  $\{\Delta\}$  are located with respect to the foundation axis.

72. The forces  $\{F\}_i$  due to the pile loads on the pile cap are in equilibrium with a set of forces  $\{q\}_i$  at the coordinate center of the pile cap.

73. Equilibrium yields

$$\{q\}_i = \{C\}_i \{F\}_i \quad (7)$$

in which  $\{C\}_i$ , the statics matrix for a three-dimensional system, is

$$\{C\}_i = \begin{bmatrix} 1 & 0 & 0 & 0 & 0 & 0 \\ 0 & 1 & 0 & 0 & 0 & 0 \\ 0 & 0 & 1 & 0 & 0 & 0 \\ 0 & -U_3 & U_2 & 1 & 0 & 0 \\ U_3 & 0 & -U_1 & 0 & 1 & 0 \\ -U_2 & U_1 & 0 & 0 & 0 & 1 \end{bmatrix}$$

where

$u_1 = U_1$  coordinate of the pile, LENGTH.

$u_2 = U_2$  coordinate of the pile, LENGTH.

$u_3 = U_3$  coordinate of the pile, LENGTH.

#### Foundation stiffness analysis

74. If the piling cap is assumed rigid, then the deflection of the pile cap can be related to the deflection of the piling in the foundation axis coordinate by

$$\{X\}_i = \{C\}_i^T \{\Delta\} \quad (8)$$

75. The foundation load  $\{Q\}$  is distributed to each piling so that

$$\{Q\} = \sum_{i=1}^n \{q\}_i \quad (9)$$

where  $n$  = number of piles. The relationships between the foundation load and the pile cap deflections are

$$\{Q\} = \{S\}\{\Delta\} \quad (10)$$

in which  $\{S\}$  is the stiffness influence coefficients matrix for the foundation as a whole. The  $\{S\}$  matrix is found by introducing the contribution of each individual pile toward the stiffness of a pile cap. This yields

$$\{q\}_i = \{S'\}_i \{\Delta\} \quad (11)$$

in which

$$\{S'\}_i = \{C\}_i \{a\}_i \{b\}_i \{a\}_i^T \{C\}_i^T \quad (12)$$

and finally

$$\{S\} = \sum_{i=1}^n \{S'\}_i \quad (13)$$

where  $\{a\}$  is the transformation matrix of force and displacement of the pile (rotated and/or battered) axis to the foundation axis.

76. Once the stiffness matrix is known for the total foundation, the problem is essentially solved and only requires back substitution to find the distribution of loads to the individual piling. It should be noted that the foundation stiffness matrix  $\{S\}$  is independent of the external loads.

#### Loads and displacements

77. The displacements of the pile cap can be found by inverting the foundation stiffness matrix  $\{S\}$  and multiplying it by the external load matrix  $\{Q\}$ , or

$$\{\Delta\} = \{S\}^{-1}\{Q\} \quad (14)$$

78. Once the foundation deflections are known, the deflections of pile  $i$  about its own axis can be found by

$$\{X\}_i = \{s\}_i^T \{C\}_i^T \{\Delta\} \quad (15)$$

79. Finally, the forces allotted to each pile about its axis can be found from Equation 6 where

$$\{F\}_i = \{b\}_i \{X\}_i \quad (6 \text{ bis})$$

#### Forces and Deflections of Individual Piles

80. The approach followed in obtaining the forces and deflections on the individual piles is as follows. The modulus of reaction, the material properties of the pile, and the pile length are used to determine the pile-head stiffness matrix for a single pile, assuming a linear elastic pile-soil system. This pile-head stiffness matrix is obtained by using a finite element computer code (Marlin, Jones, and Radhakrishnan, in preparation), which is a one-dimensional finite element analysis of a beam on an elastic foundation.

81. The pile-head stiffness matrix is then used as input in another computer program that uses the direct stiffness analysis to obtain the forces and deflections of the piles.

82. A beam on elastic foundation analysis is then performed, and the pressure, moment, and deflection along the length of the most critically loaded pile is determined. The analysis assumes that the top of the pile is pinned to the base of the monolith and that the monolith base is rigid. These assumptions are adequate for the dam construction of Leech Lake Dam.

83. The results of the three-dimensional direct stiffness pile foundation analysis are presented in Table 9. The allowable loads on the piles are as follows:

Maximum allowable compressive load per pile = 124 kips

Maximum allowable shear load per pile = 8.5 kips

Maximum allowable tensile load per pile = 0 kips

Maximum allowable moment in a pile = 131,000 in-lb or  
10.9 kip-ft

84. It is interesting to note that for this pile foundation the approximate rigid body analysis (results presented in Table 8) gives pile loads which compare well with the results of the direct stiffness analysis as presented in Table 9.

85. The axial, or compressive, loads were well below the allowables based on the strength of the pile. The shear load for the normal operation plus ice case loading was above the allowable. For normal operation plus ice loading, the average shear load was 10.75 kips per pile in relation to the allowable of 8.5 kips per pile.

86. The horizontal and vertical deflections of the piles were below the allowable for one-quarter inch and therefore were acceptable.

87. The pressure, moment, and deflection in the most critically loaded pile are presented in Figure 50. They were within the allowables.

88. The normal operation with ice case loading produced tension in the upstream piling as determined by the direct stiffness method of analysis. There was a possibility that if the row of piling farthest upstream was neglected the remaining piling would not be in tension, and the piling layout would be adequate since the axial load and deflections are well below allowables. However, when this analysis was performed with the upstream row of piles neglected, the tension in the second row of piles became greater than 12.65 kips. This indicated that to counteract an ice loading of one foot or more at the dam, remedial measures should be performed that would eliminate any possibility of tension in the piling under the dam.

89. This measure could be accomplished by posttensioning the piers into the foundation with the use of soil anchors. By an iterative procedure using the direct stiffness method of analysis, it was determined that a force of 55 kips is required in a vertical direction in the center and three feet from the upstream end of each pier at Leech Lake Dam. A hole (Figure 51) should be drilled into the pier at the angle indicated, and soil anchors, with at least a 60-kip capacity, should be

installed and then posttensioned to about 20 kips. The reason for not applying the total posttensioning is to keep the posttensioning stress low under normal operating conditions but have the posttensioning potential available. If the monoliths tend to lift up, the strand could then develop the necessary resistance for adequacy of the piling system to resist any tensile forces. Under this procedure minimum stresses are induced into the monoliths and will cause less tendency for cracking during normal operating conditions. After the posttensioning is completed, the space around the cables in the piers should be grouted.

90. With the posttensioning placed at the indicated angle, adequate resistance to shear at the top of the piling will be provided. This would make the piling system at Leech Lake Dam adequate in stability.

## PART VI: CONCLUSIONS AND RECOMMENDATIONS

### Foundation

91. The soil-piling system, which supports the monoliths at Leech Lake Dam, is adequate except the shear and tensile loads at the top of piles are excessive. The foundation material has reliable in situ supporting capabilities. The pilings have been continuously submerged and therefore should be nondeteriorated and adequate. During the drilling program for the Upper Mississippi Headwater Structures, pieces of planks, beams, and piling were obtained at various locations that support this conclusion.

92. The piling layout is not adequate because some piles are in tension for the normal operation plus ice loading, and the shear stress at the top of the piles is also excessive. It is recommended to post-tension the monoliths as presented in Figure 51. This procedure should create a stress condition in the foundation to insure adequate stability at Leech Lake Dam. The proposed slant-hole soil anchor system needs special consideration and should be carefully designed.

### Concrete

93. The concrete is of good quality with the only deterioration caused by surface freezing and thawing. It is recommended that within the next 5 years an acrylic-polymer coating as discussed in Part IV be investigated and, if adequate, be used to rehabilitate the deteriorated surface concrete. It is necessary to rehabilitate the surface concrete in order to stop water from entering cracks and accelerating the deterioration of the interior concrete as the freezing and thawing process continues at Leech Lake Dam. If the deterioration is allowed to continue until major replacement of the concrete is required, the rehabilitation will be very expensive.

94. After the remedial measures and rehabilitation, it is expected that this structure will be adequate for many more years of service.

#### REFERENCES

- Baguelin, F., Jiziquel, J. F., and Shields, D. H. 1978. "The Pressuremeter and Foundation Engineering," Trans Tech Publications, First Edition.
- Hrennikoff, A. 1950. "Analysis of Pile Foundations with Batter Piles," Transactions, American Society of Civil Engineers, Vol 76, No. 1, Paper No. 2401, pp 123-126.
- Marlin, Deborah K., Jones, H. Wayne, and Radhakrishnan, N. "Documentation for LMVD PILE Program," Technical Report K-80-3, U. S. Army Engineer Waterways Experiment Station, CE, Vicksburg, Miss.
- Saul, W. E. 1968. "Static and Dynamic Analysis of Pile Foundations," Journal, Structural Division, American Society of Civil Engineers, Vol 94, No. SM5, pp 1071-1100.
- U. S. Army Engineer District, St. Paul. 1973. "Reservoirs at Headwaters, Mississippi River, Minnesota, Leech Lake Dam, Periodic Inspection Report No. 1," Corps of Engineers, St. Paul, Minn.
- U. S. Army Engineer District, St. Paul. 1977. "Mississippi River, Headwaters Reservoirs, Master Plan for Public Use Development and Resource Management," Corps of Engineers, St. Paul, Minn.
- Southern Pine Association, "Modern Timber Engineering," Scofield and O'Brien, 1954.
- Davisson, M. T., (1970), "Lateral Load Capacity of Piles," Highway Research Record, No. 333, pp 104-112.

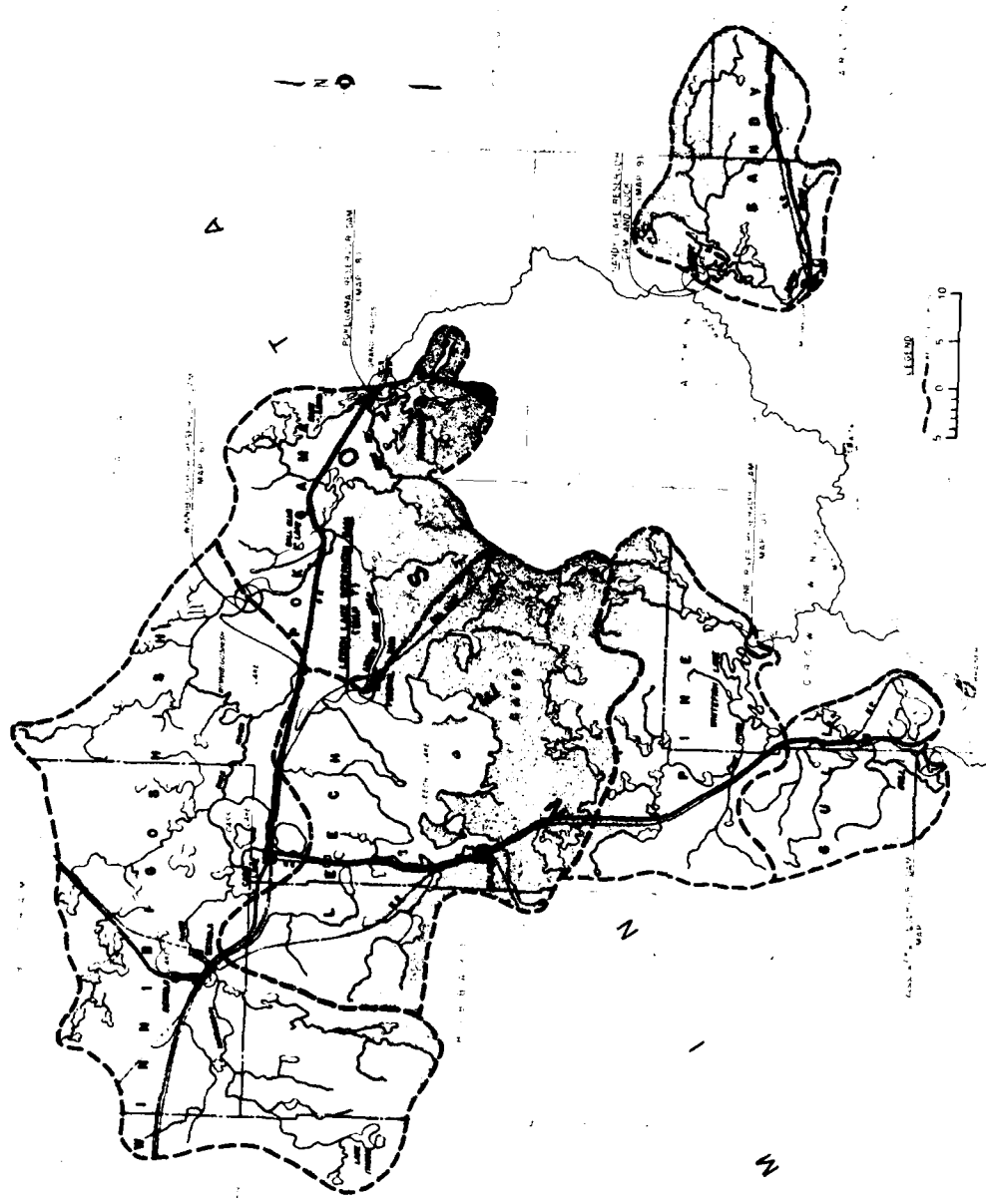

Figure 1. General project map of the Mississippi River Headwaters Reservoirs

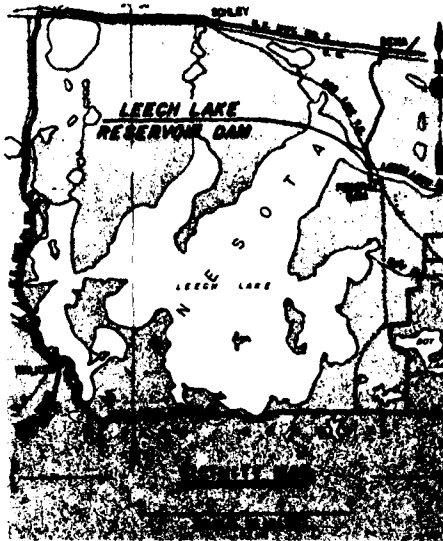

Figure 2. Vicinity map of  
Leech Lake Reservoir

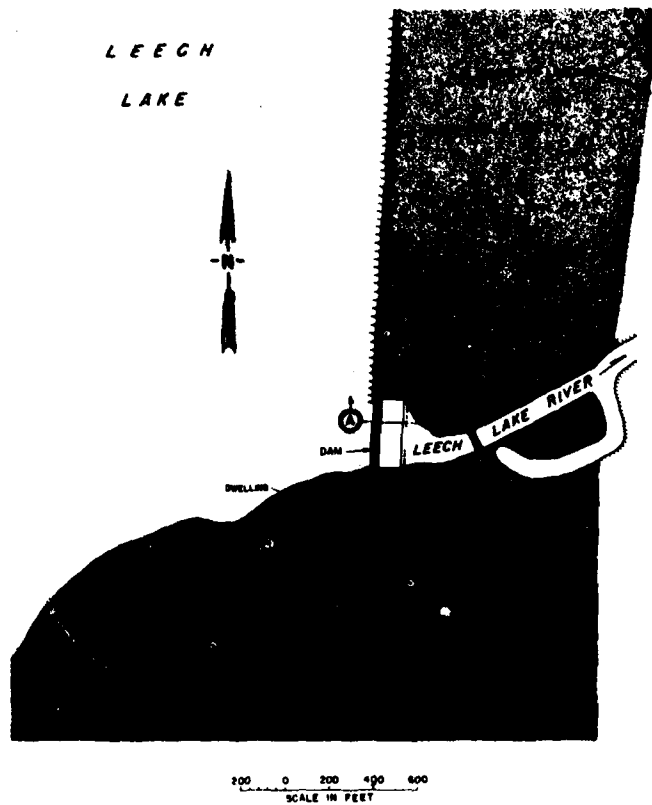

Figure 3. Plan map, Leech Lake Reservoir  
and Dam

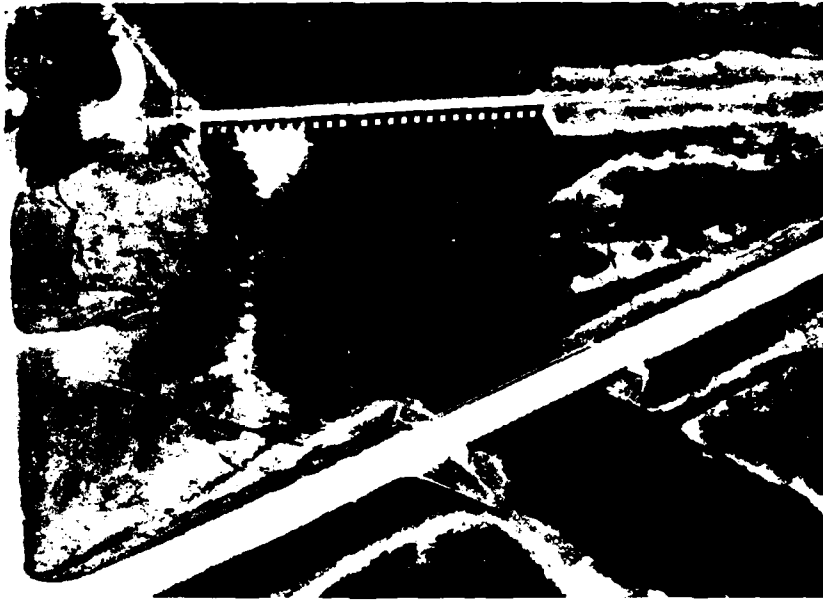
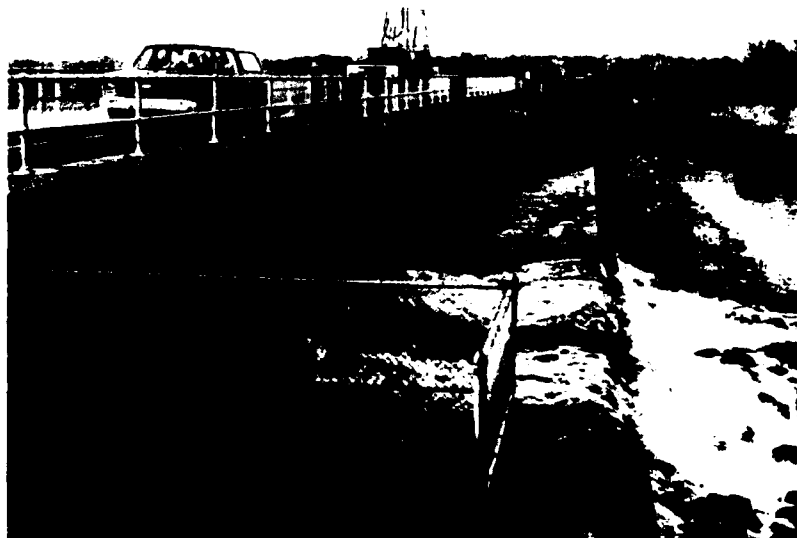

Figure 4. Aerial view of Leech Lake Dam



a. Downstream to upstream



b. Right to left abutment

Figure 5. Views of Leech Lake Dam



Figure 6. Failure of 14 piers and left abutment  
at Leech Lake Dam



a. View from downstream to upstream



b. View from roadway

Figure 7. Typical drill rig set-up for obtaining concrete core

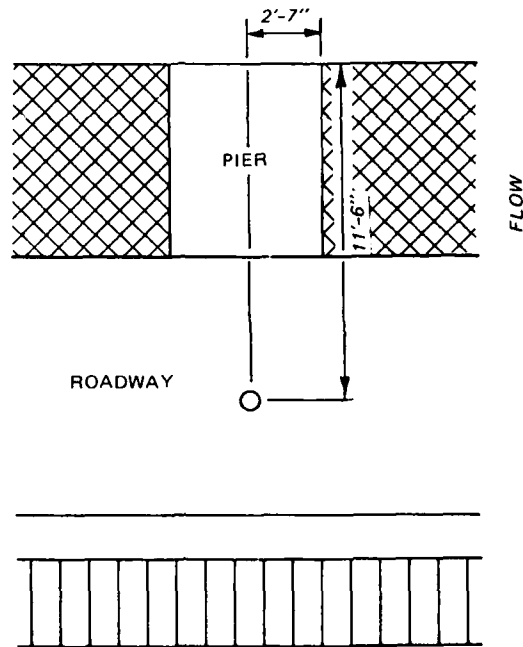
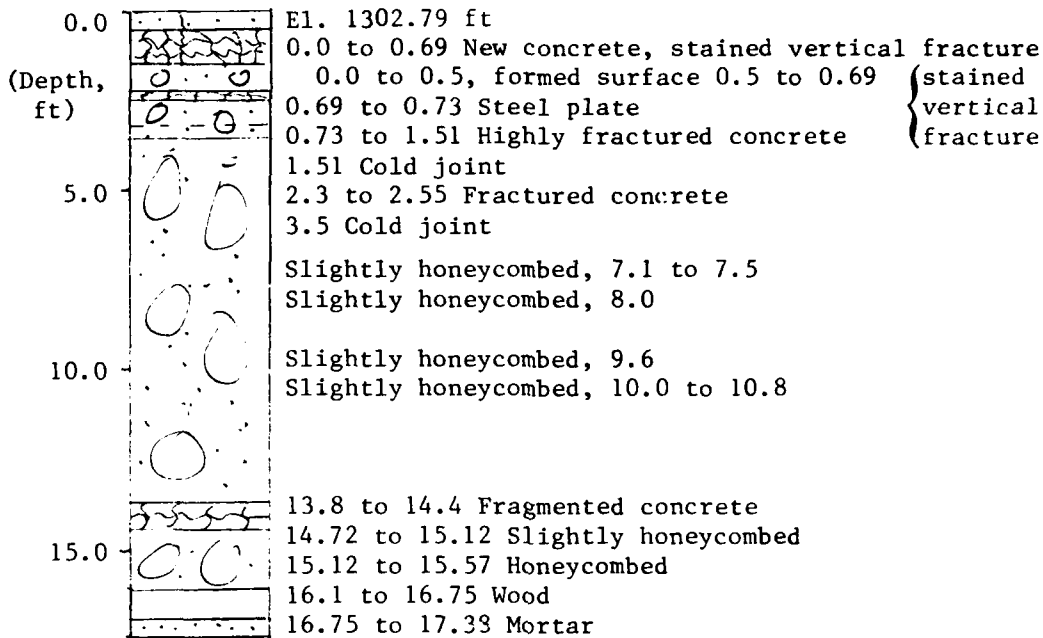

Figure 8. Typical location of a core hole in piers 5, 14, and 24



Figure 9. Representative concrete core and cut section



1-in. maximum size  
siliceous and carbonate  
gravel aggregate in  
bridge deck concrete.

2-in. maximum size  
igneous and metamorphic  
aggregate in pier con-  
crete.

Some alkali-silica gel in  
voids and coating  
aggregate throughout  
core.

Nonair-entrained con-  
crete.



Figure 10. Vertical NX concrete core, L-P5, Leech Lake Dam

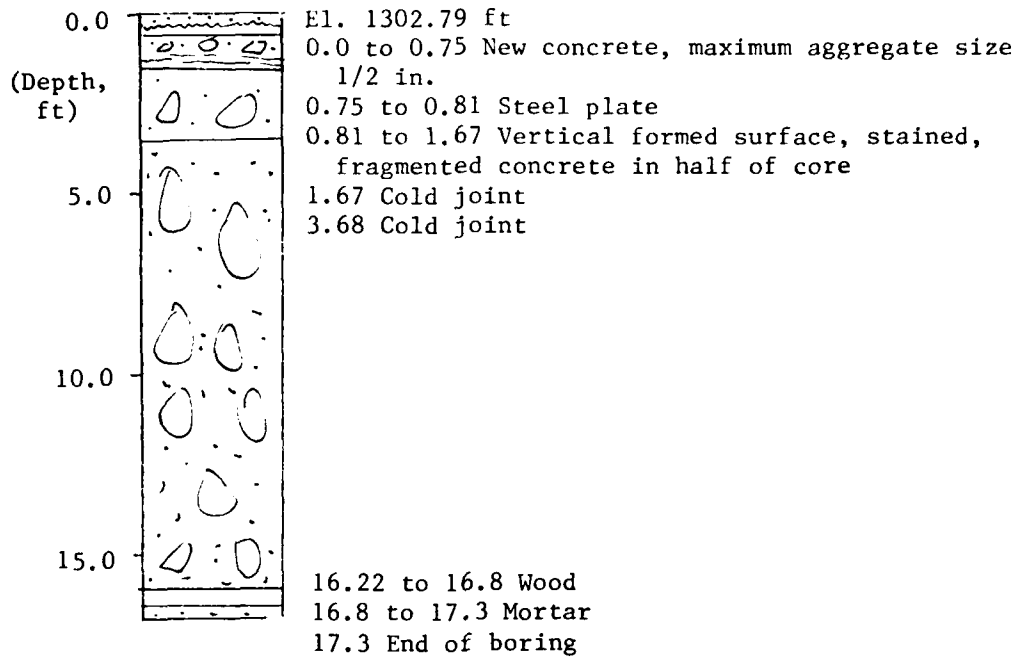

The overlay contained gravel aggregate of siliceous and carbonate rock particles. Original concrete contained 1-in. maximum size aggregate composed of igneous and metamorphic rock particles. Good consolidation, non-air-entrained concrete. Some alkali-silica gel present in voids and coating aggregate throughout core.



Figure 11. Vertical NX concrete core, L-P14, Leech Lake Dam

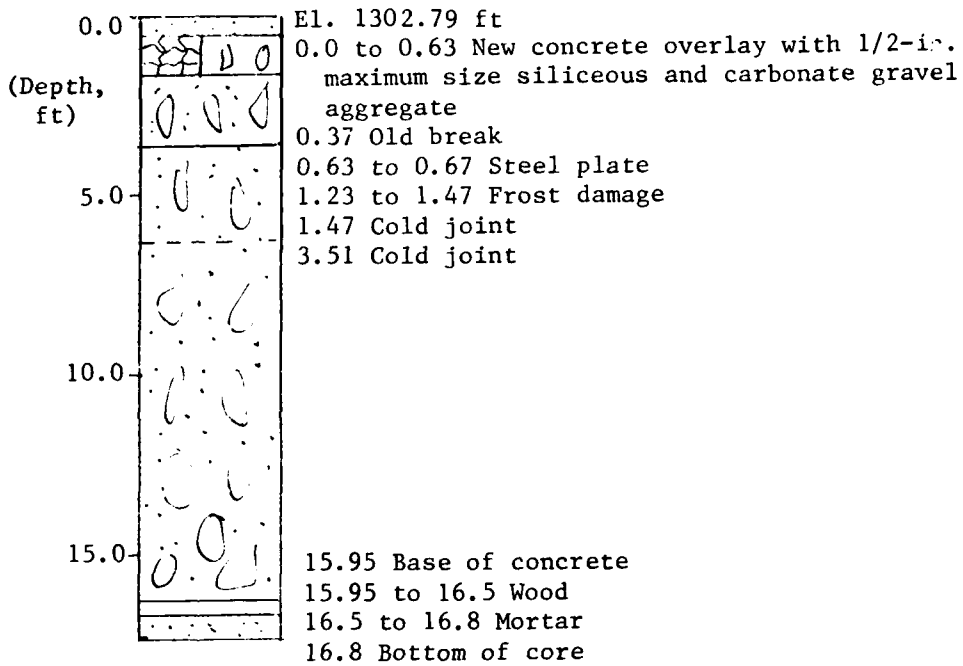

2-in. maximum size igneous and metamorphic aggregate in pier concrete. Good consolidation of non-air-entrained concrete. Some alkali-silica gel present in voids and coating aggregate throughout core.



Figure 12. Vertical NX concrete core, L-P24, Leech Lake Dam

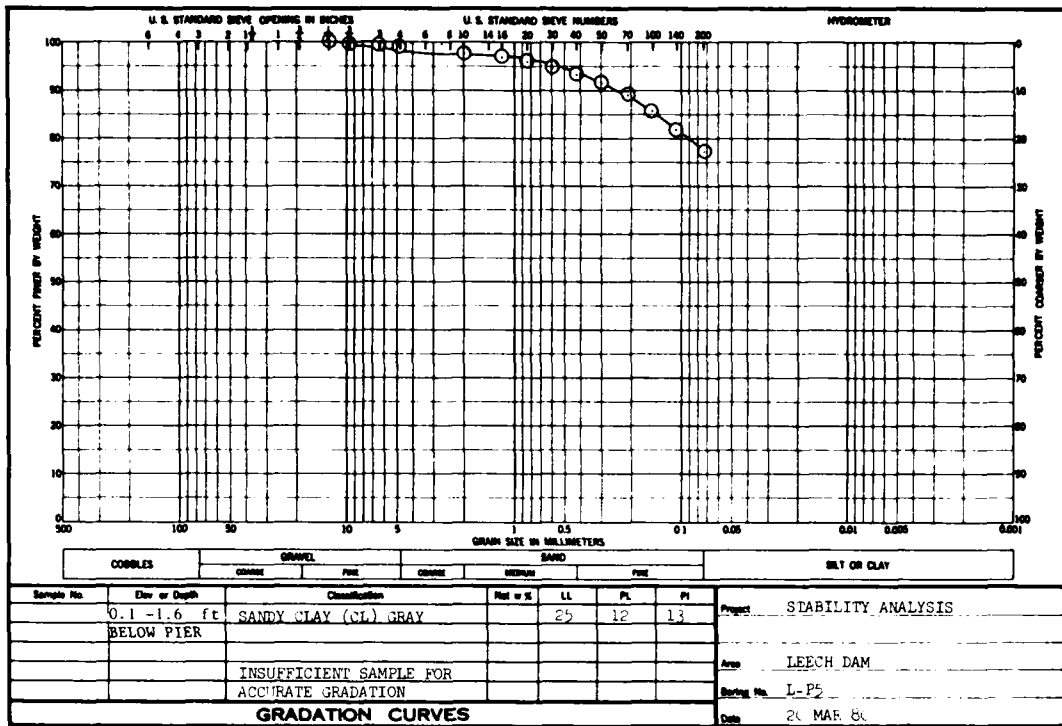

Figure 13. Foundation soil sieve analysis and classification, L-P5, 0.1-1.6 ft

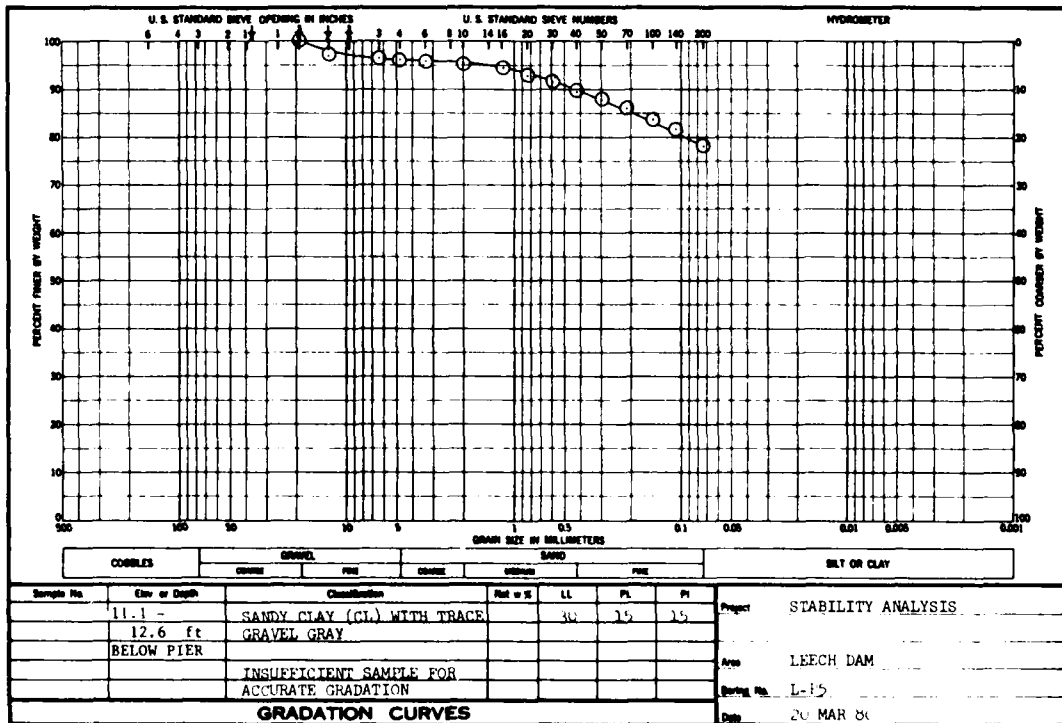

Figure 14. Foundation soil sieve analysis and classification, L-P5, 11.1-12.6 ft

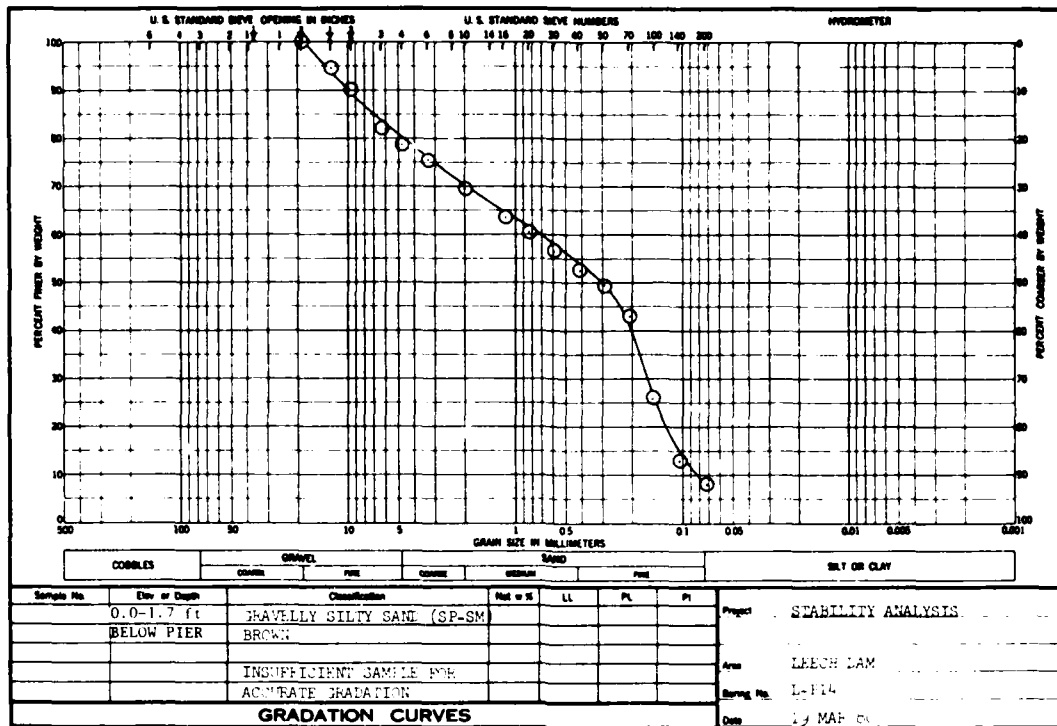

Figure 15. Foundation soil sieve analysis and classification, L-P14, 0.0-1.7 ft

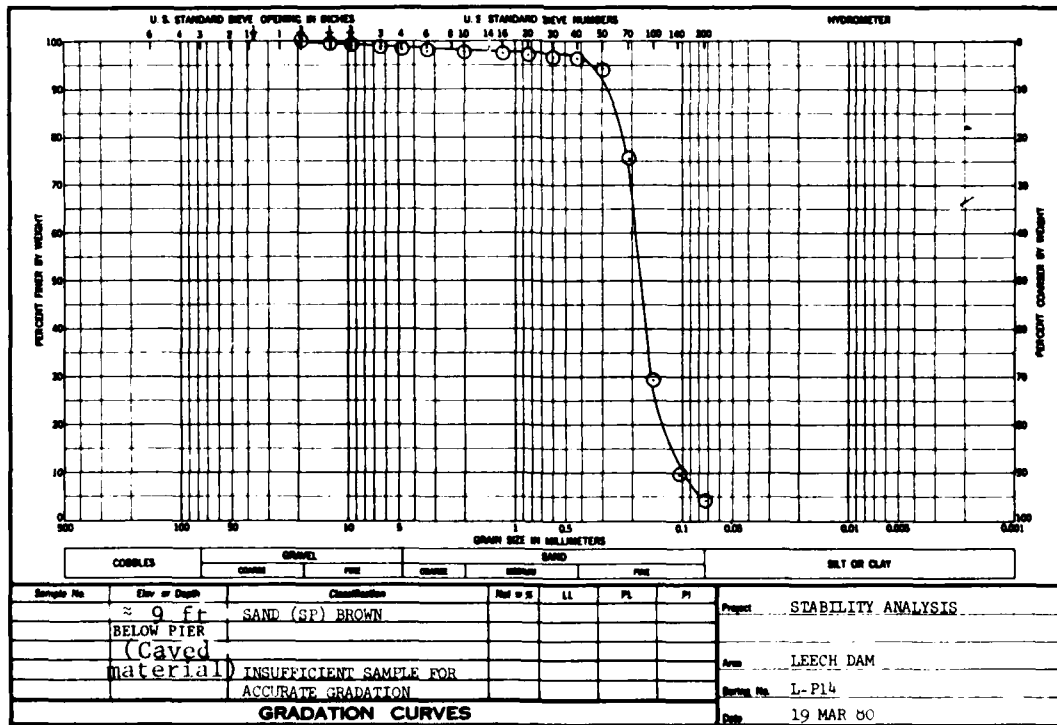

Figure 16. Foundation soil sieve analysis and classification, L-P14, ≈ 9 ft

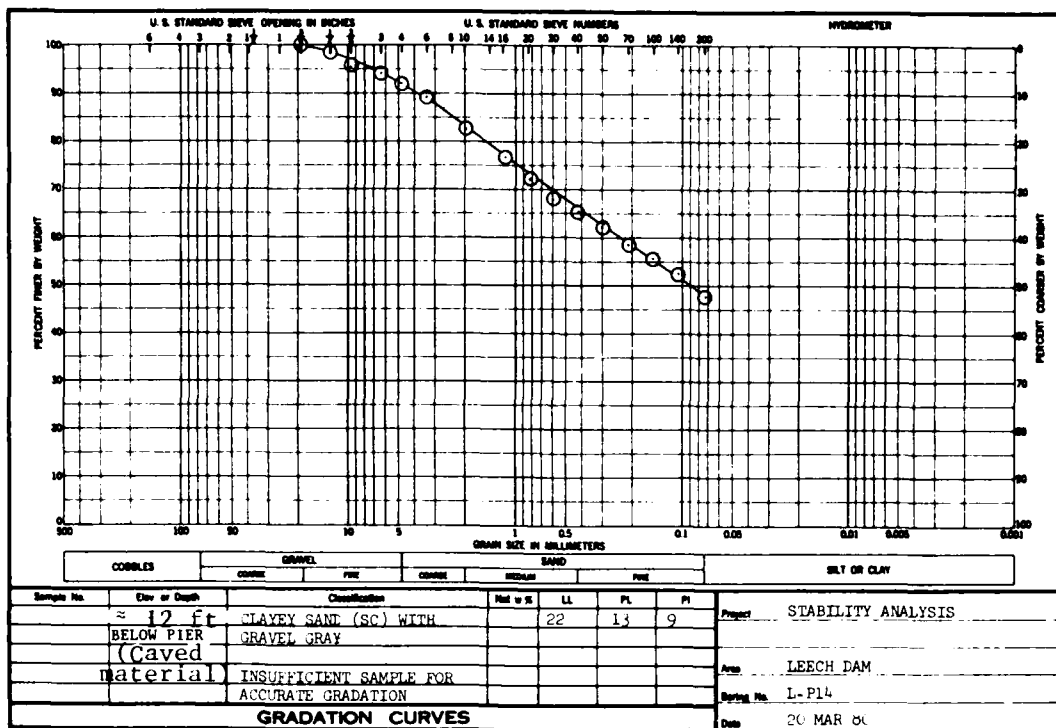

Figure 17. Foundation soil sieve analysis and classification, L-P14, ≈ 12 ft

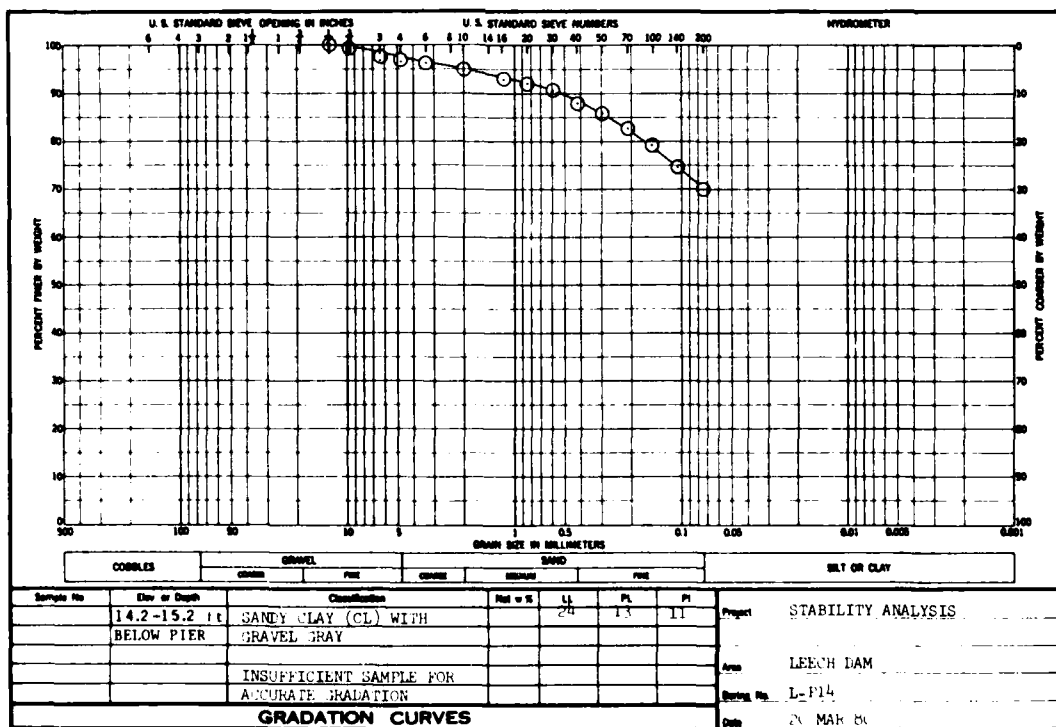

Figure 18. Foundation soil sieve analysis and classification, L-P14, 14.2-15.2 ft

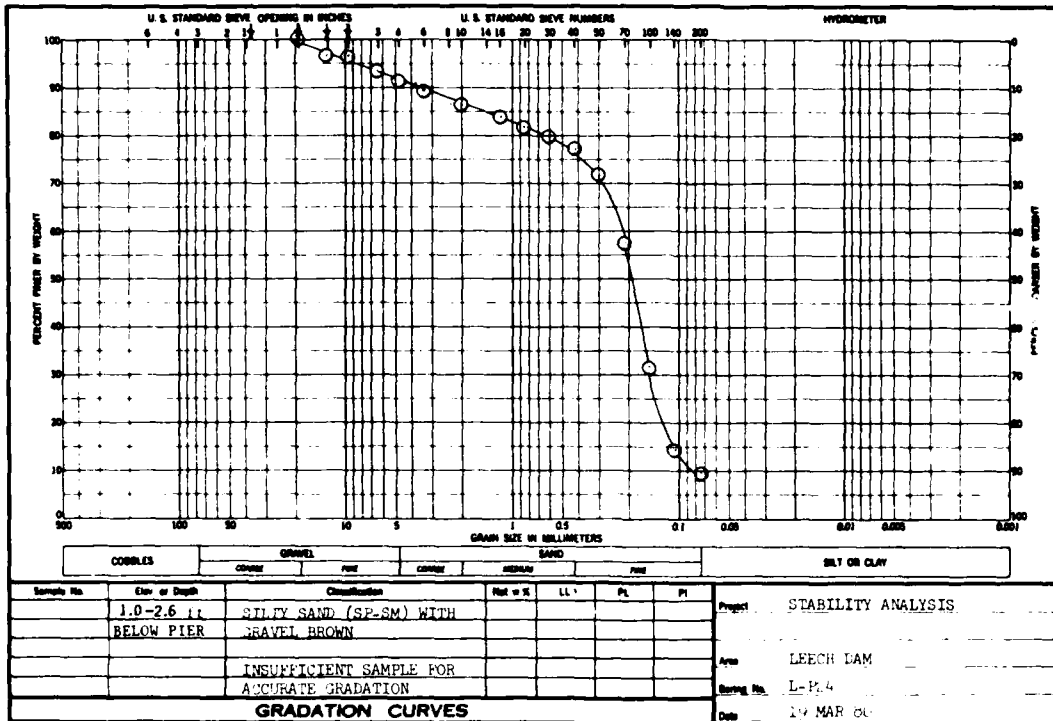

Figure 19. Foundation soil sieve analysis and classification, L-P24, 1.0-2.6 ft

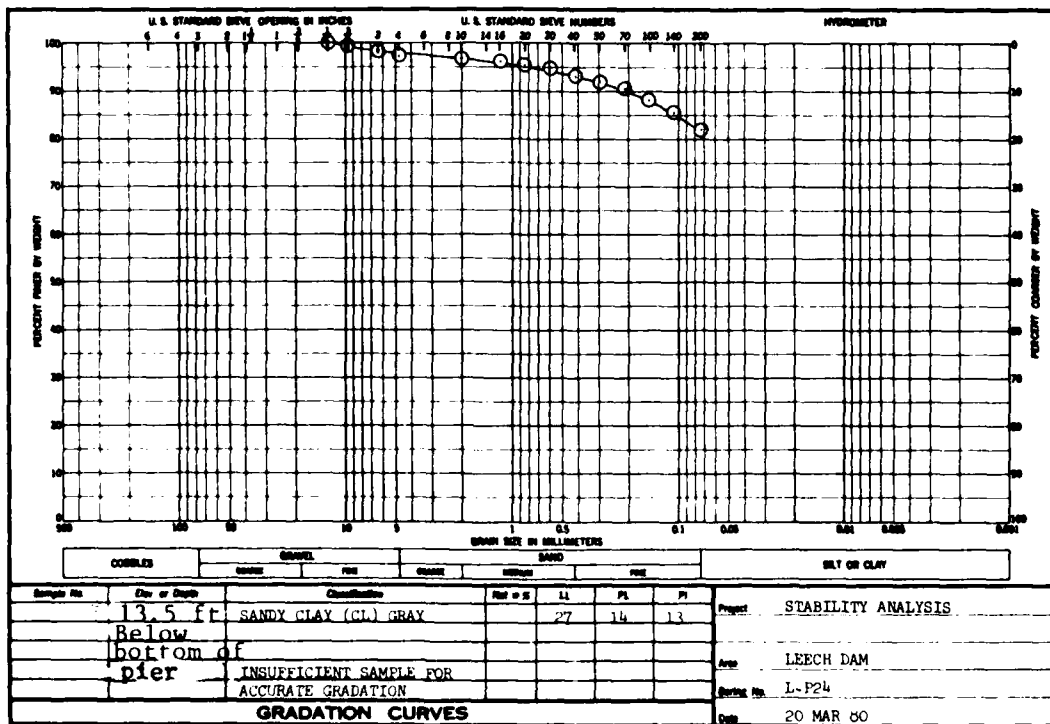
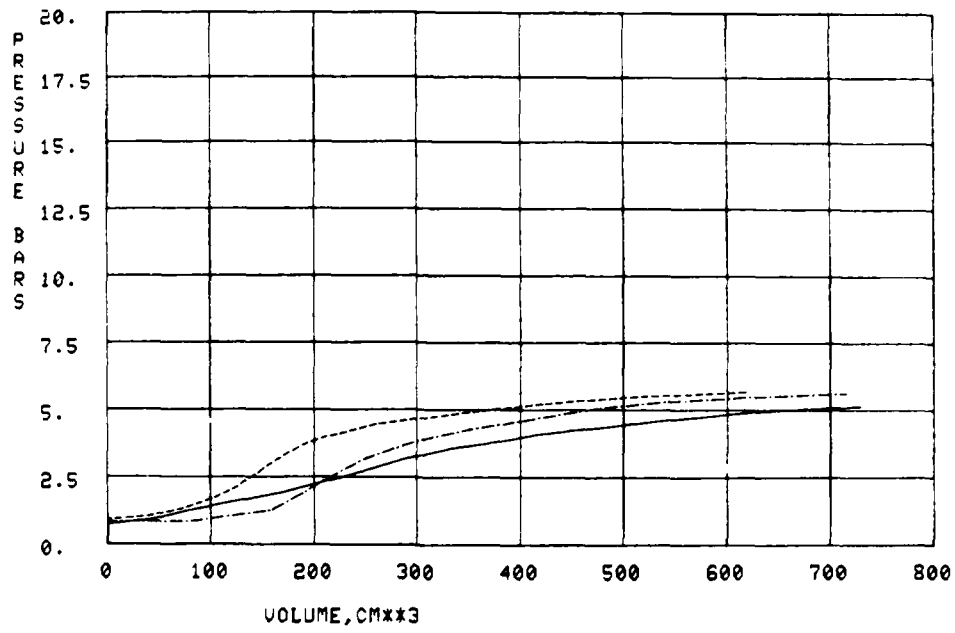
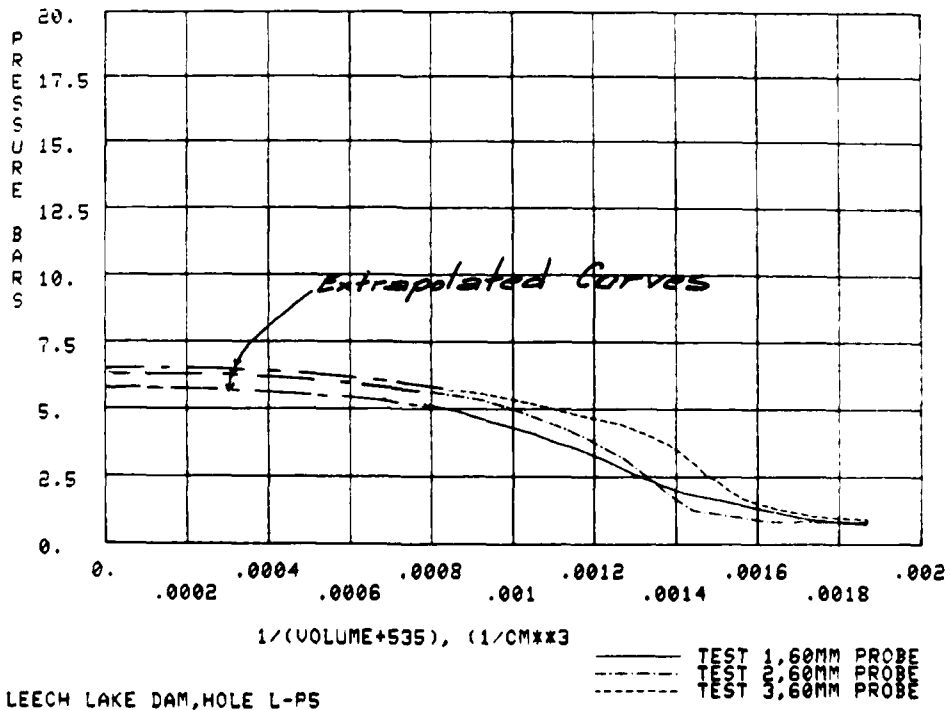

Figure 20. Foundation soil sieve analysis and classification, L-P24, ~ 13.5 ft



LEECH LAKE DAM, HOLE L-P5

Figure 21. Pressure versus volume (metric unit), L-P5



LEECH LAKE DAM, HOLE L-P5

Figure 22. Limit pressure determination, L-P5

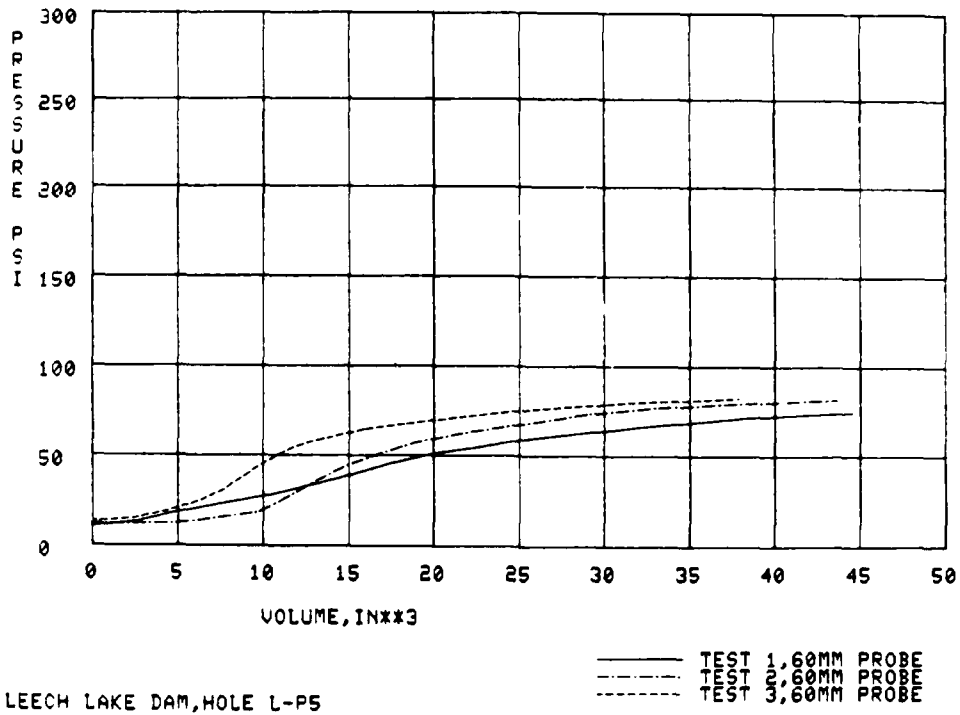

Figure 23. Pressure versus volume, L-P5

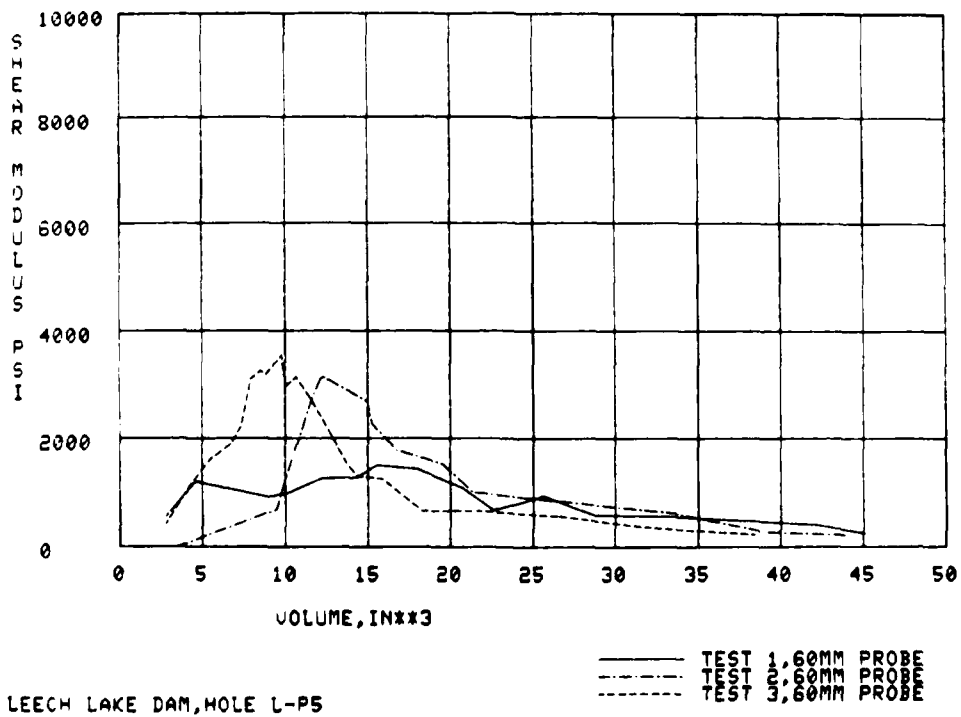

Figure 24. Shear modulus, L-P5

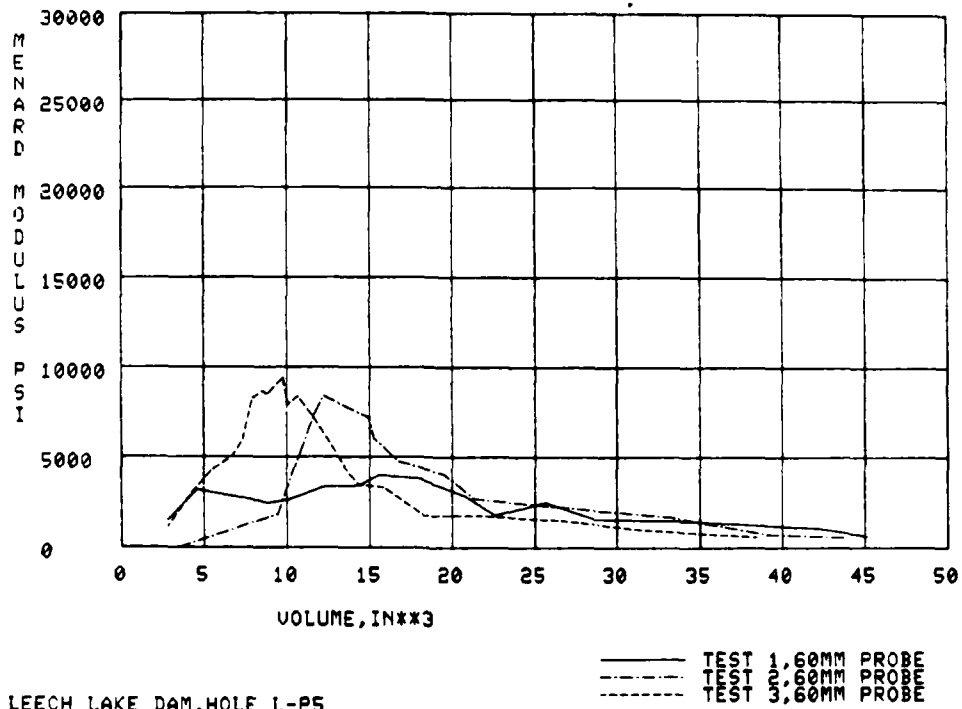

Figure 25. Ménard modulus, L-P5

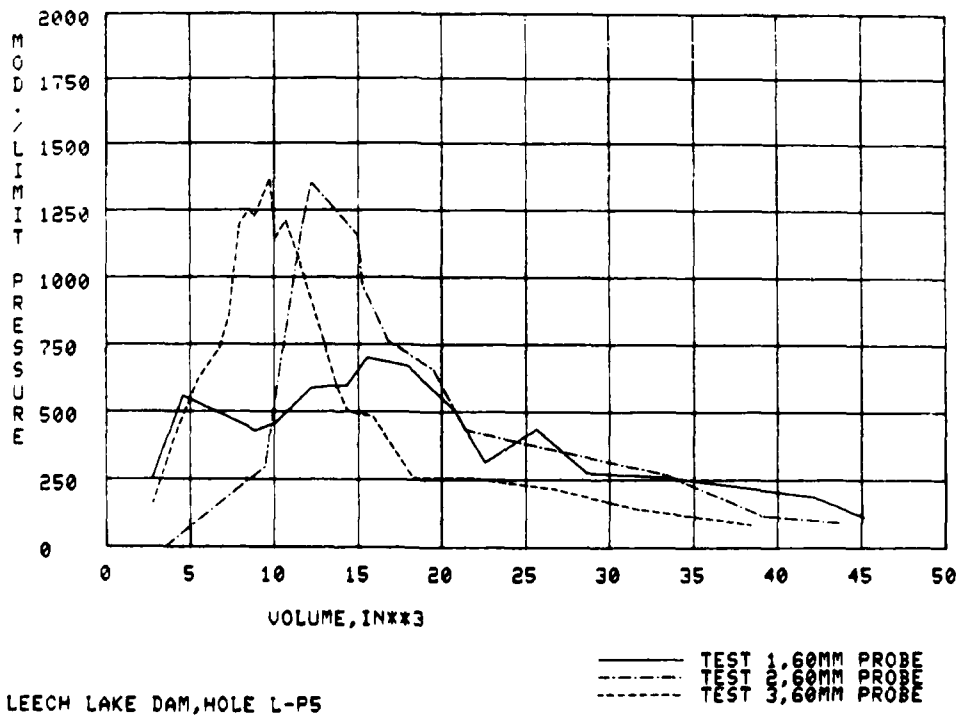
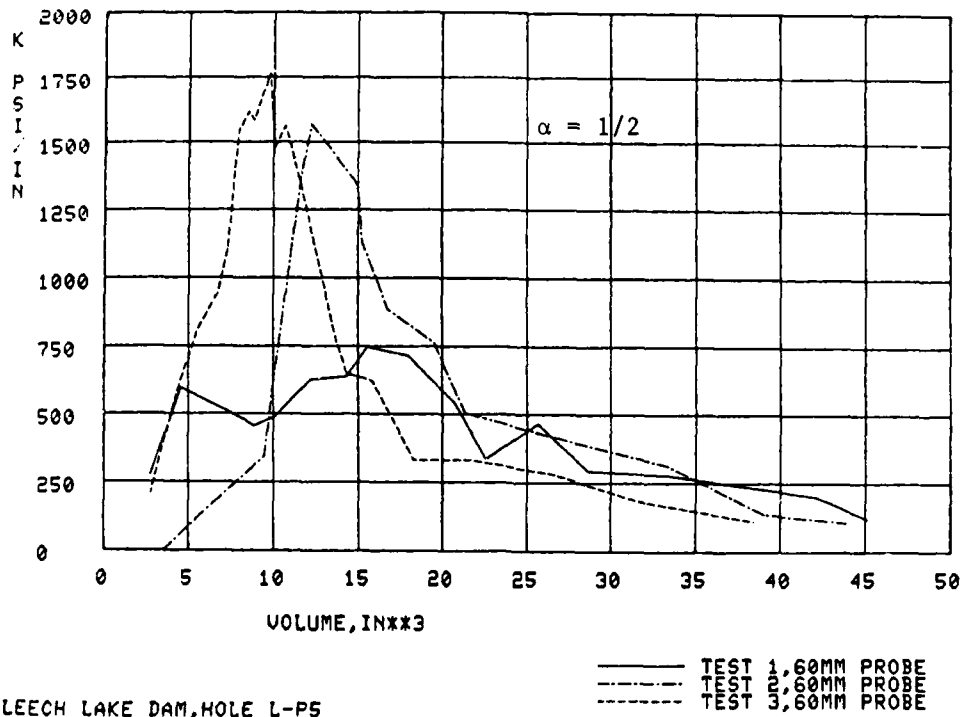
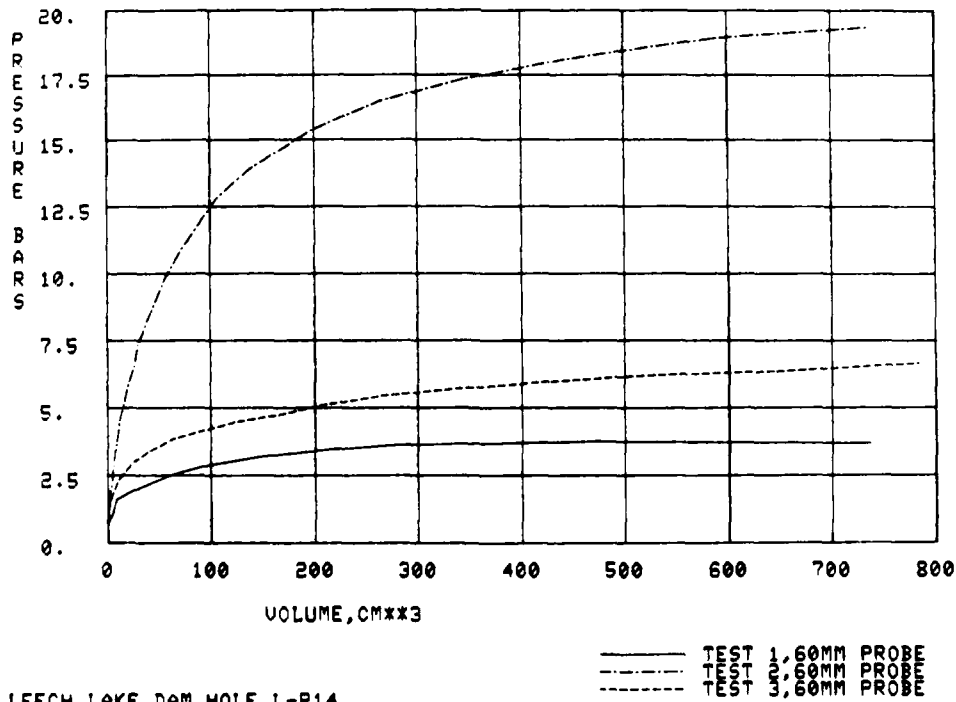

Figure 26. Ménard modulus divided by limit pressure, L-P5



LEECH LAKE DAM, HOLE L-P5

Figure 27. Modulus of subgrade reaction, L-P5



LEECH LAKE DAM, HOLE L-P14

Figure 28. Pressure versus volume (metric unit), L-P14

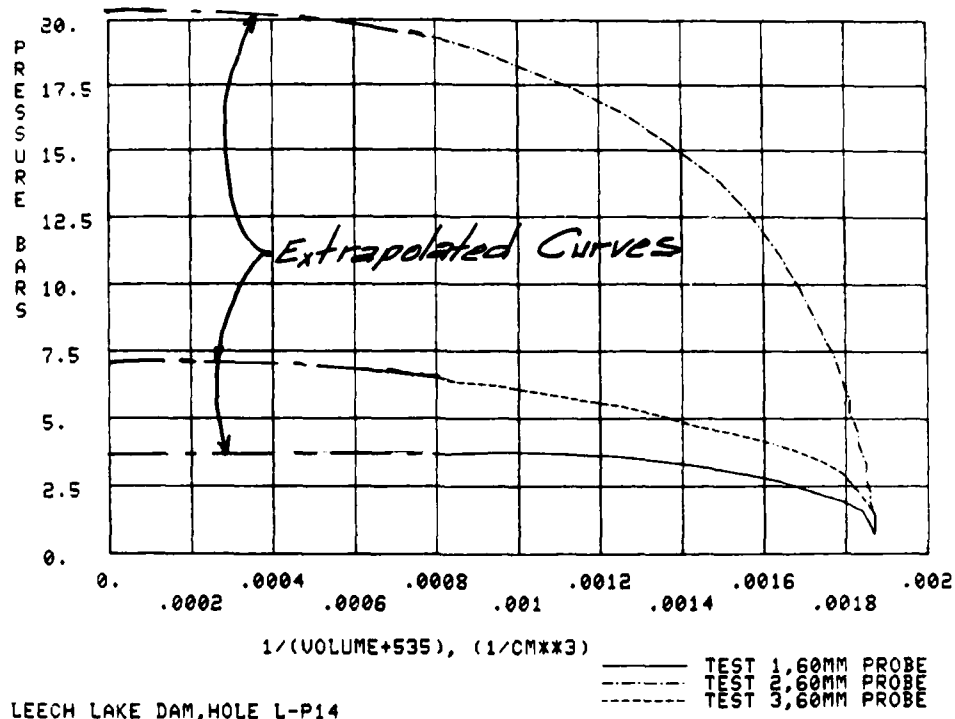

Figure 29. Limit pressure determination, L-P14

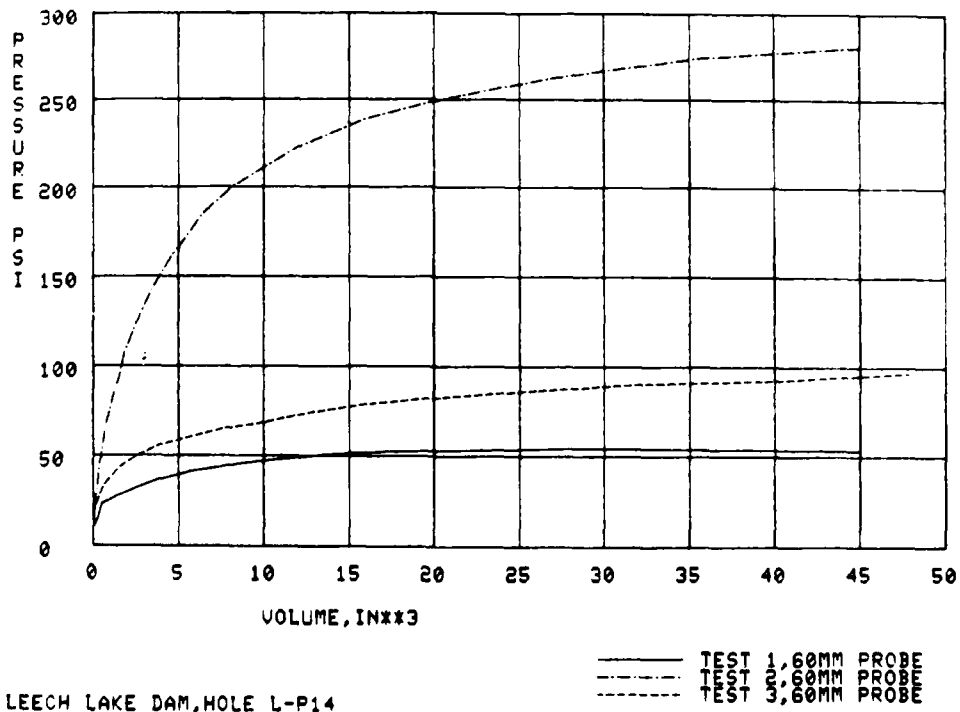

Figure 30. Pressure versus volume, L-P14

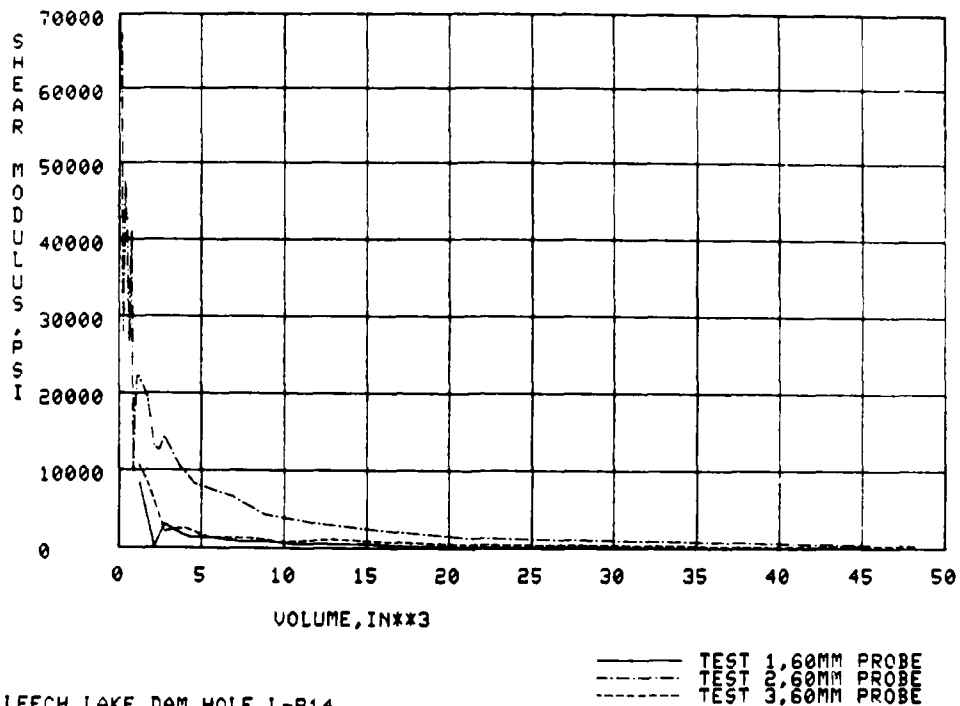

Figure 31. Shear modulus, L-P14

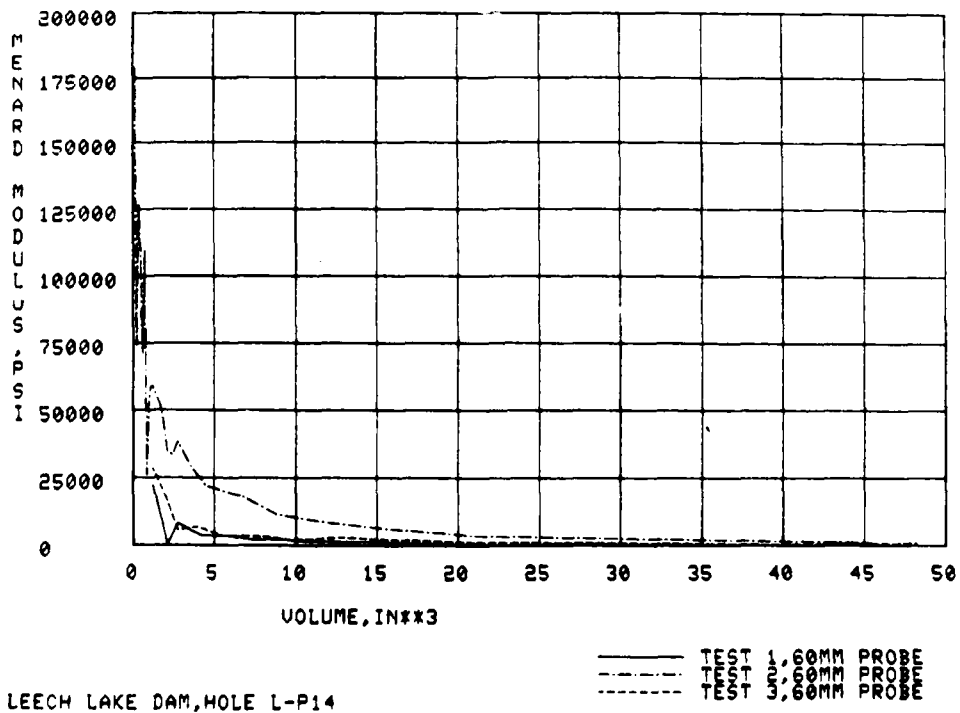

Figure 32. Ménard modulus, L-P14

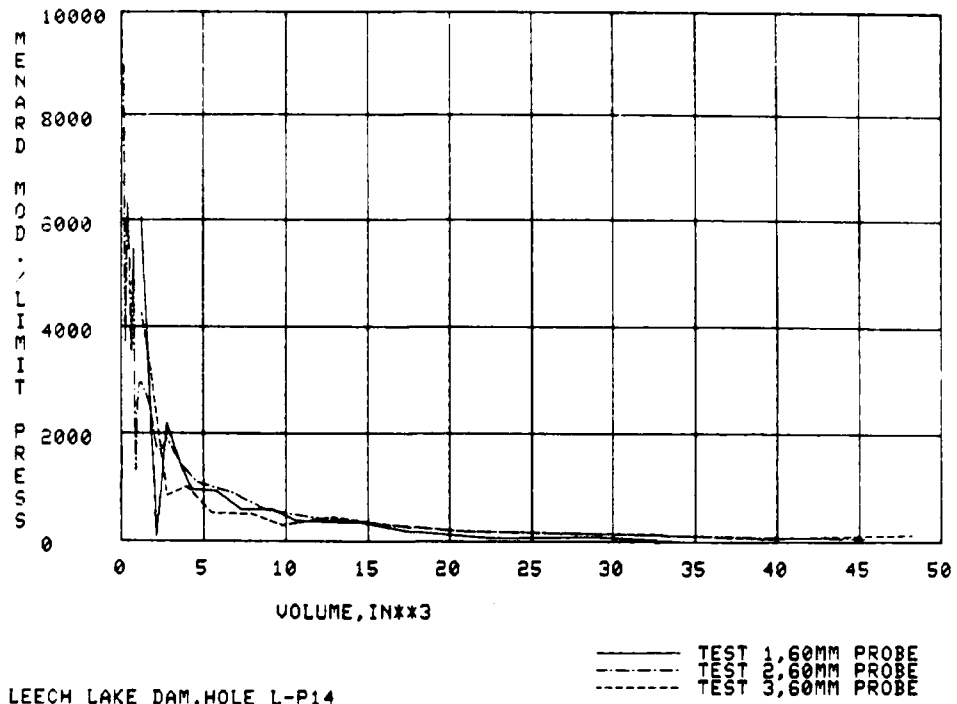

Figure 33. Ménard modulus divided by limit pressure, L-P14

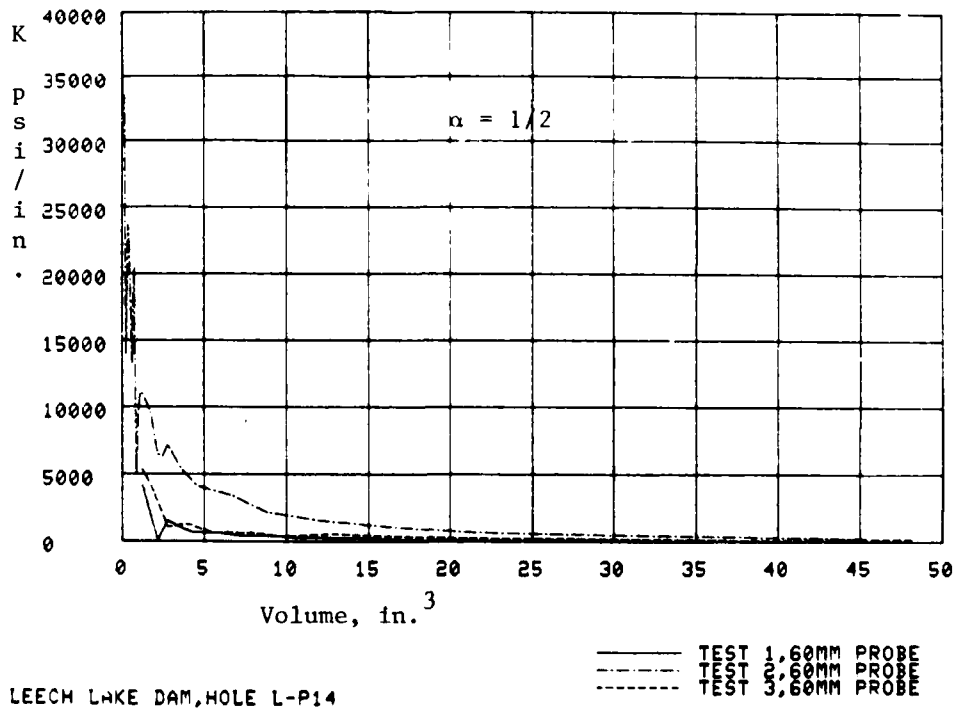
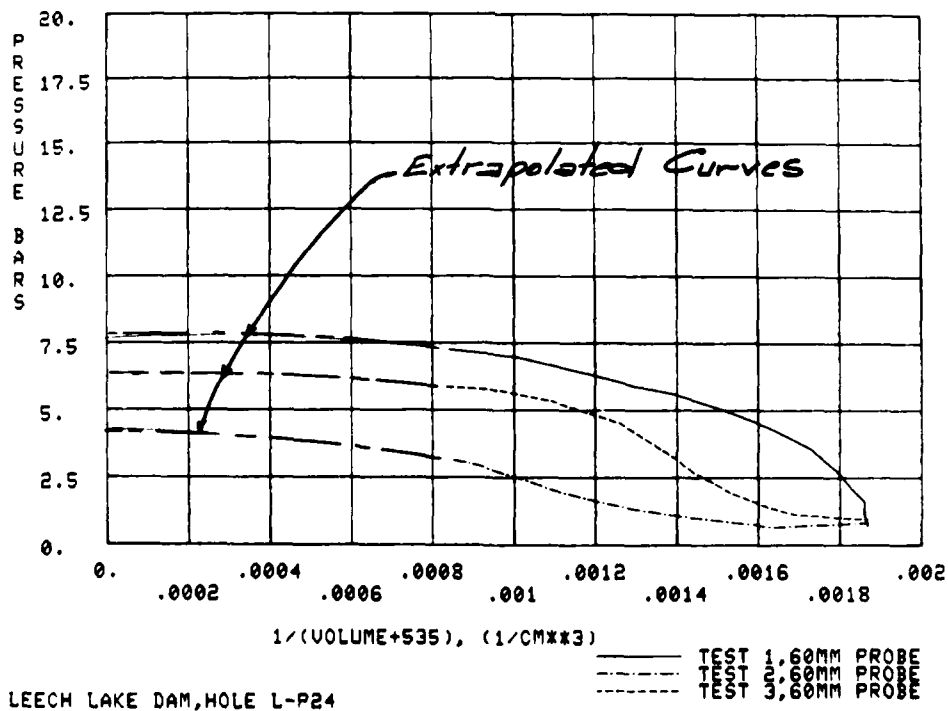
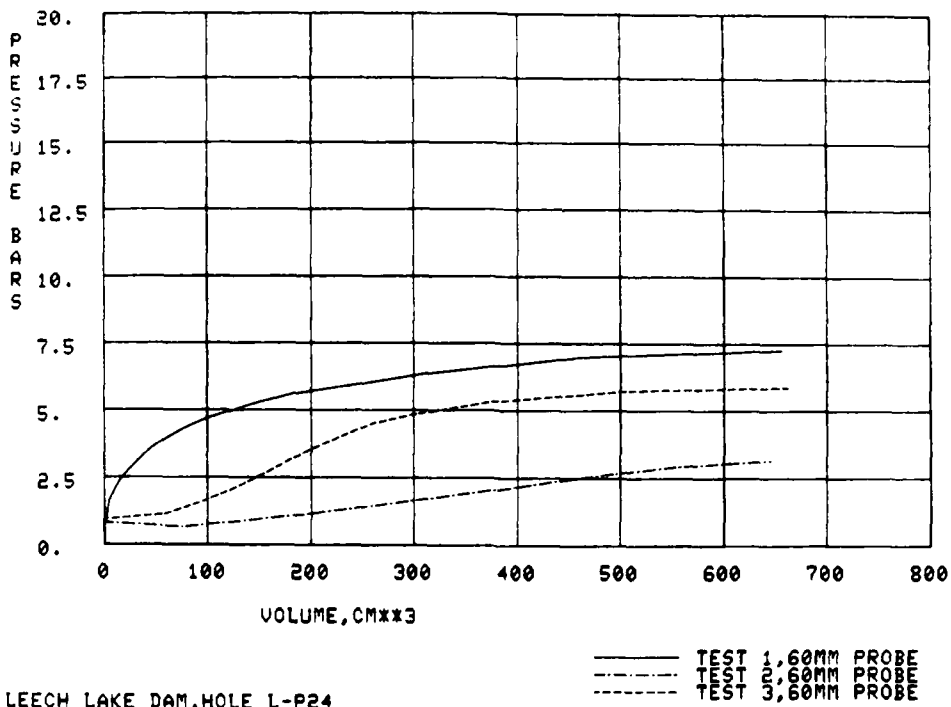

Figure 34. Modulus of subgrade reaction, L-P14



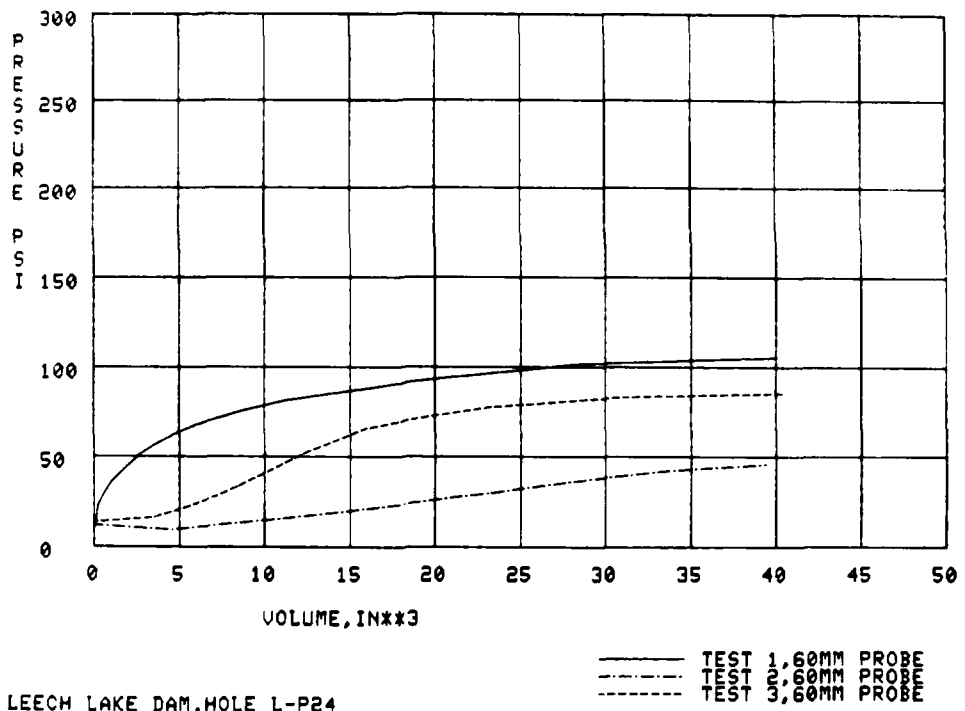

Figure 37. Pressure versus volume, L-P24

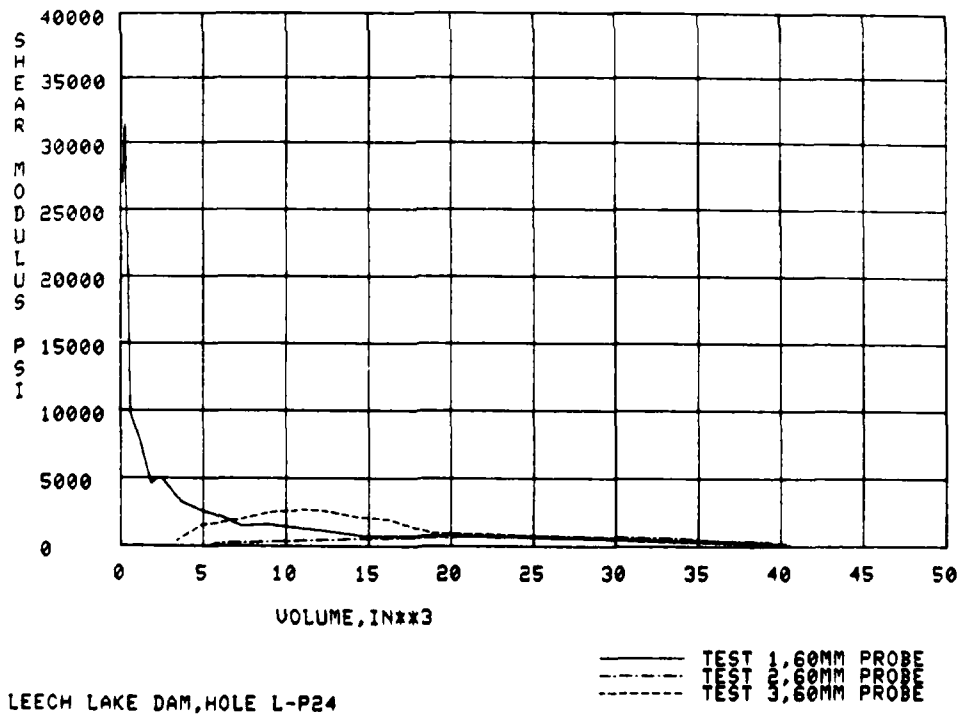

Figure 38. Shear modulus, L-P24

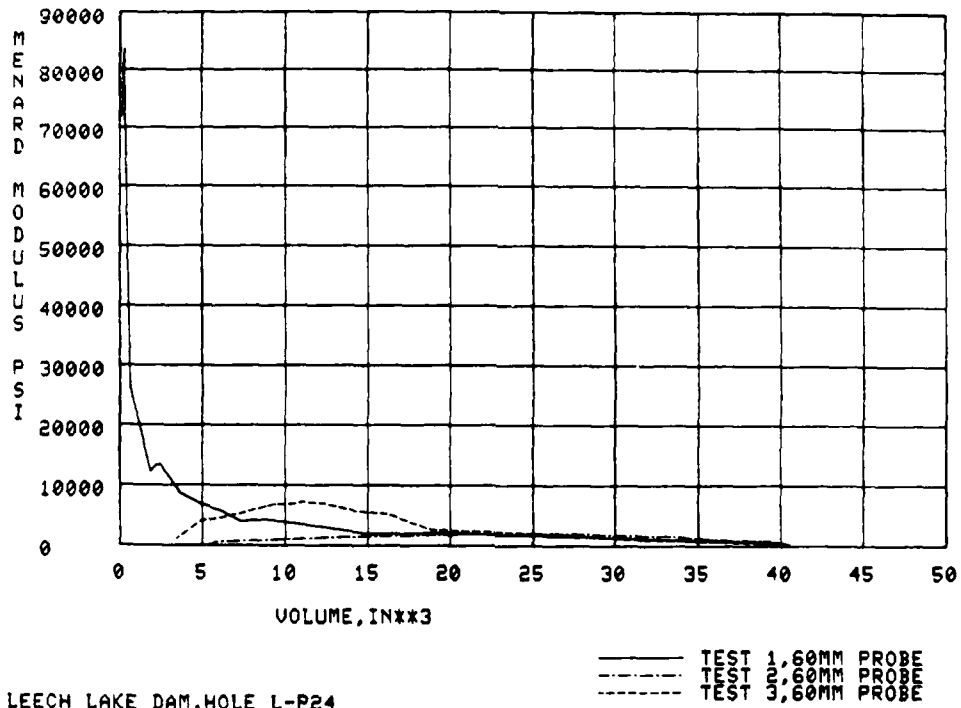

Figure 39. Ménérd modulus, L-P24

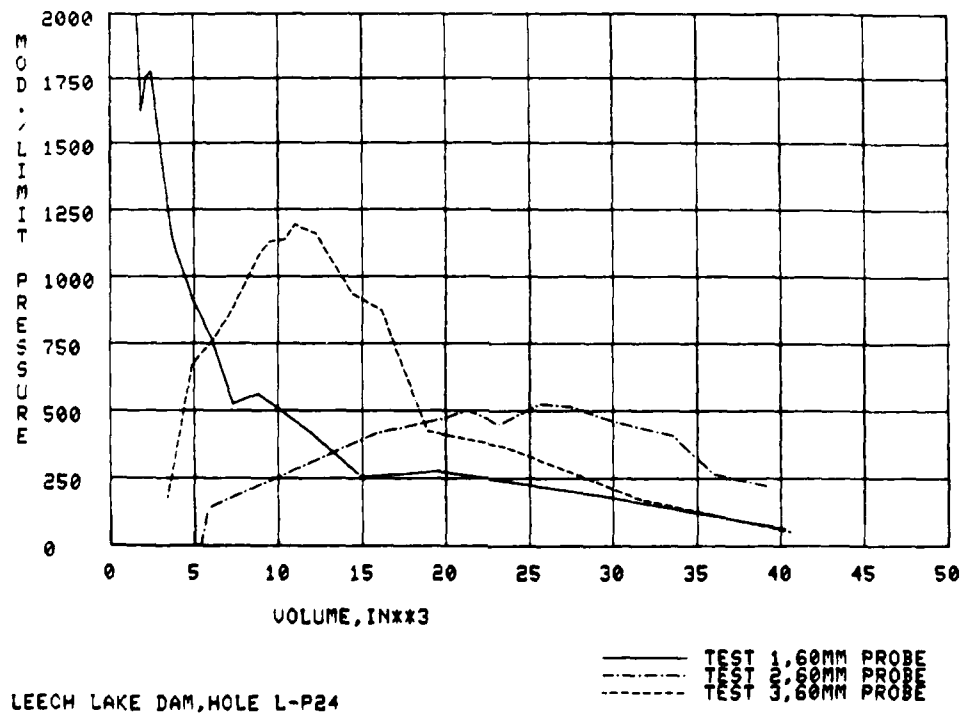
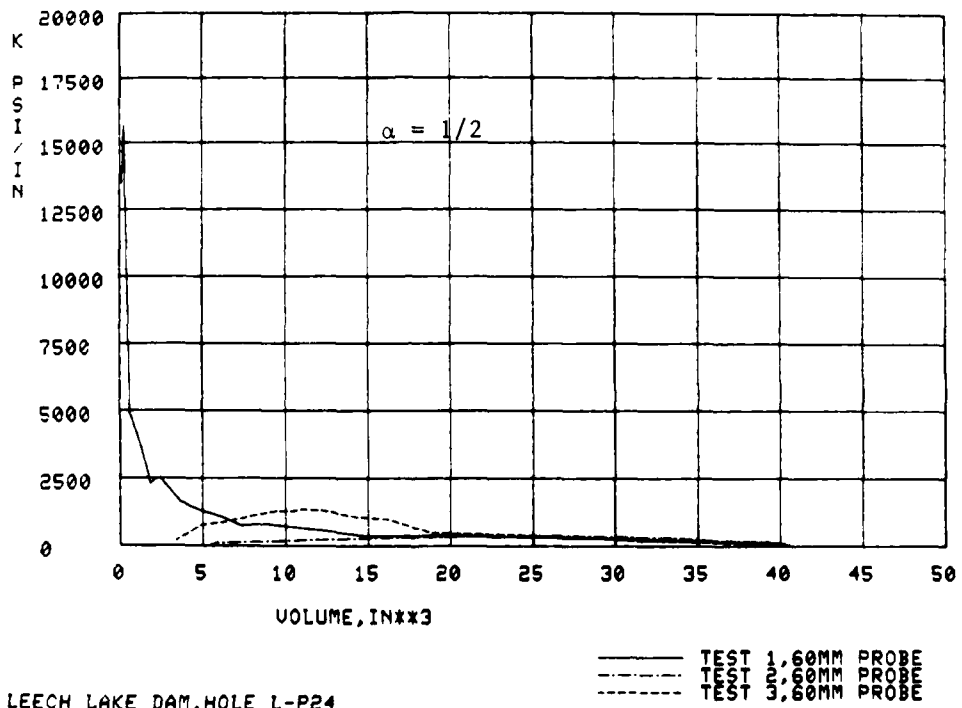

Figure 40. Ménérd modulus divided by limit pressure, L-P24



LEECH LAKE DAM, HOLE L-P24

Figure 41. Modulus of subgrade reaction, L-P24

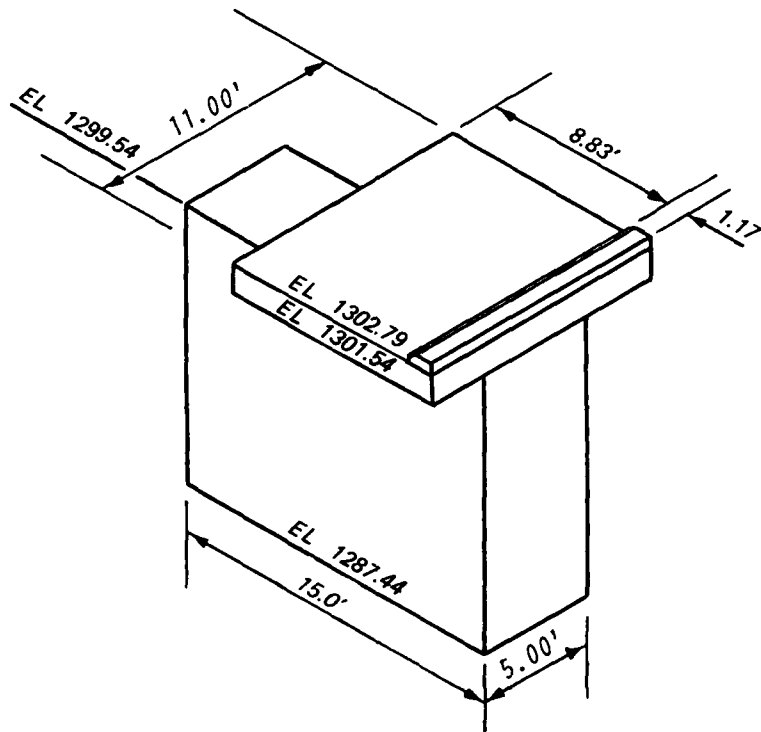

Figure 42. Schematic of a pier and the roadway from center line to center line

Item	Factor	F <sub>y</sub> (kips)	F <sub>z</sub> (kips)	Arm <sub>y</sub> (ft)	Arm <sub>z</sub> (ft)	M <sub>x</sub> (ft-kip)
W <sub>Conc</sub>	(0.15)(1303.29 - 1302.79)(1)(11)		0.83	0.50		0.4
	(0.15)(1302.79 - 1301.54)(10)(11)		20.63	5.00		103.2
	(0.15)(1301.54 - 1299.54)(9)(1.67)		4.51	5.00		22.6
	(0.15)(1299.54 - 1287.44)(15)(5)		136.13	7.50		1,021.0
	-(0.15)(2)(1299.54 - 1287.44)(0.58)(0.67)		-1.41	12.71		-17.9
			160.69			1,129.3
P <sub>Headwater</sub>	(0.0625)(1/2)(1296.94 - 1287.44) <sup>2</sup> (11)	-31.02			3.17	-98.3
Uplift	(0.0625)(1296.94 - 1284.94)( $\frac{39.5}{14.5 + 41.5 + 13}$ )(15)(5)		-32.20	7.50		241.5
	(0.0625)(1/2)(1296.94 - 1284.94)( $\frac{15}{14.5 + 41.5 + 13}$ )(15)(5)		-6.11	10.00		-61.1
			-38.31			-302.6
e = $\frac{728.4}{122.38} = 5.95$ ft						
TOTAL		-31.02	122.38			728.4

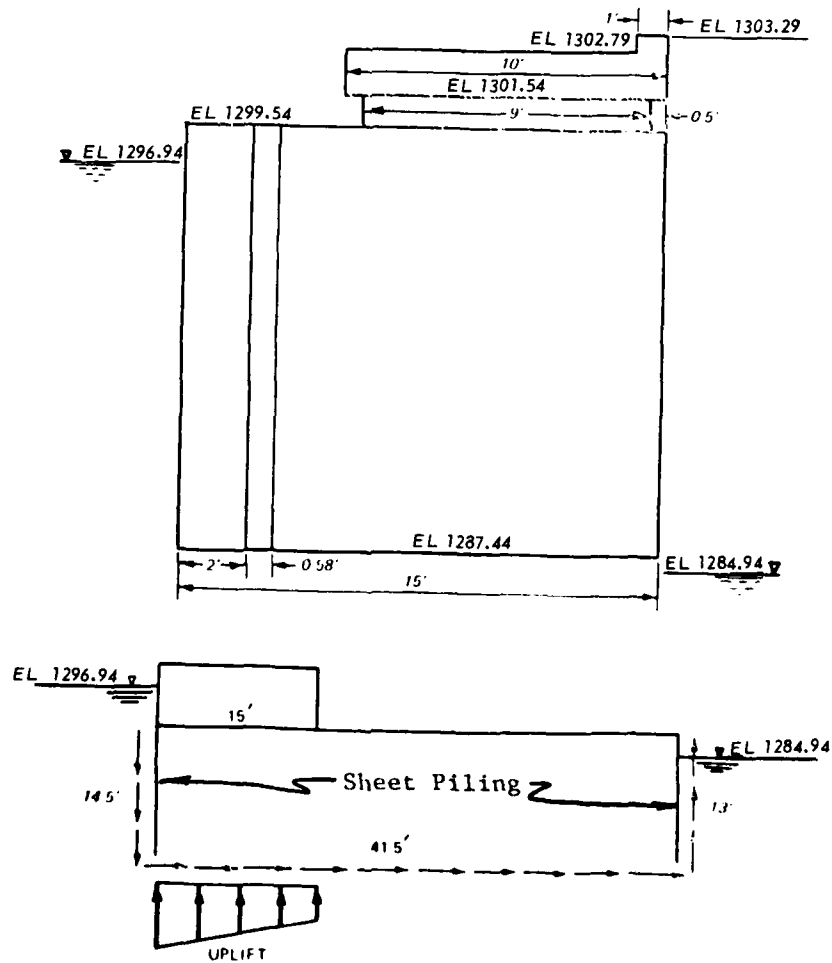

Figure 43. Normal operation case loading, Leech Lake Dam



Item	Factor	F <sub>y</sub> (kips)	F <sub>z</sub> (kips)	Arm <sub>y</sub> (ft)	Arm <sub>z</sub> (ft)	M <sub>x</sub> (ft-kip)
Loads	From Normal Operation Calculations	-31.02	122.38			728.4
Earthquake:						
Pe <sub>1</sub>	(0.025)(160.69)	-4.02			7.41	-29.8
Pe <sub>2</sub>	(2/3)(51)(0.025)(1296.94 - 1287.44) <sup>2</sup> (11)(1/1000)	-0.84			3.80	-3.2
e = $\frac{695.4}{122.38} = 5.68$ ft						
TOTAL		-35.88	122.38			695.4

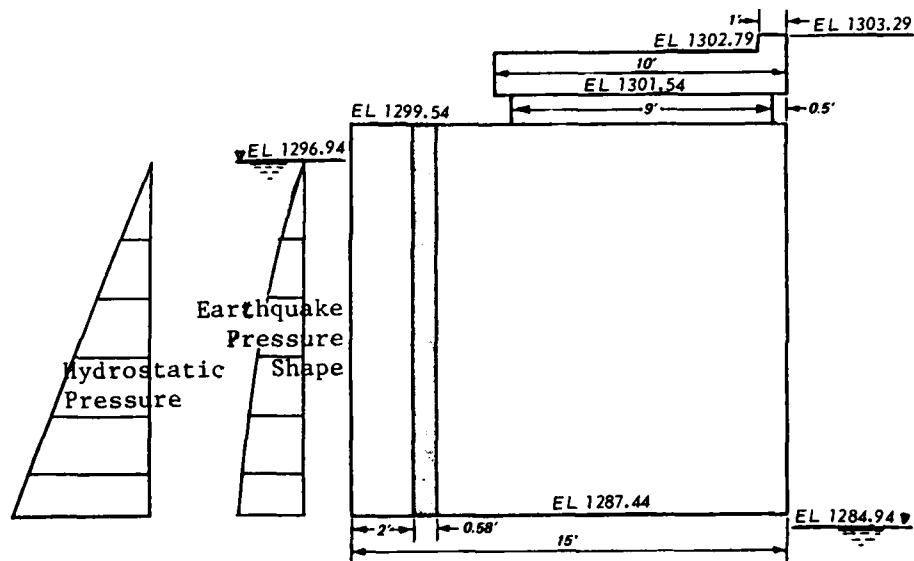

Figure 45. Normal operation with earthquake, Leech Lake Dam

LOCATION OF CENTROID OF PIER IN XZ PLANE

$(0.83)[(1/2)(1303.29 - 1302.79) + 1302.79 - 1287.44]$	=	13.0
$(20.63)[(1/2)(1302.79 - 1301.54) + 1301.54 - 1287.44]$	=	303.8
$(4.51)[(1/2)(1301.54 - 1299.54) + 1299.54 - 1287.44]$	=	59.1
$(136.13)(1/2)(1299.54 - 1287.44)$	=	823.6
$-(1.41)(1/2)(1299.54 - 1287.44)$	=	-8.5
		1,191.0

$$\bar{Z} = \frac{1,191.0}{160.69} = 7.41 \text{ ft}$$

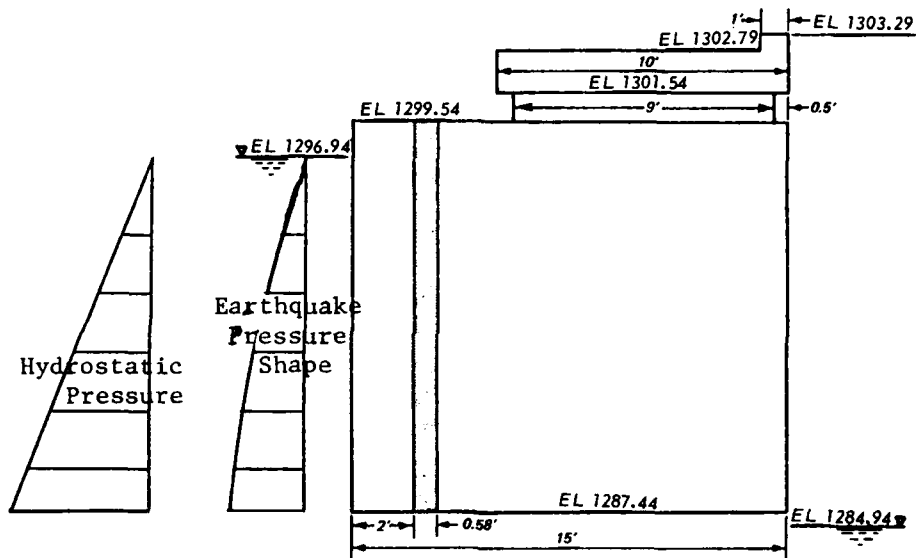

Figure 46. Normal operation with earthquake, centroid weights in YZ plane, Leech Lake Dam

Item	Factor	F <sub>y</sub> (kips)	F <sub>z</sub> (kips)	Arm <sub>y</sub> (ft)	Arm <sub>z</sub> (ft)	M <sub>x</sub> (ft-kip)
Loads	From Normal Operation Calculations	-31.02	122.38			728.4
P <sub>Ice</sub>	(1)(5)(11)	-55.00			9.00	-495.0
		$e = \frac{233.4}{122.38} = 1.91 \text{ ft}$				
TOTAL		-86.02	122.38			233.4

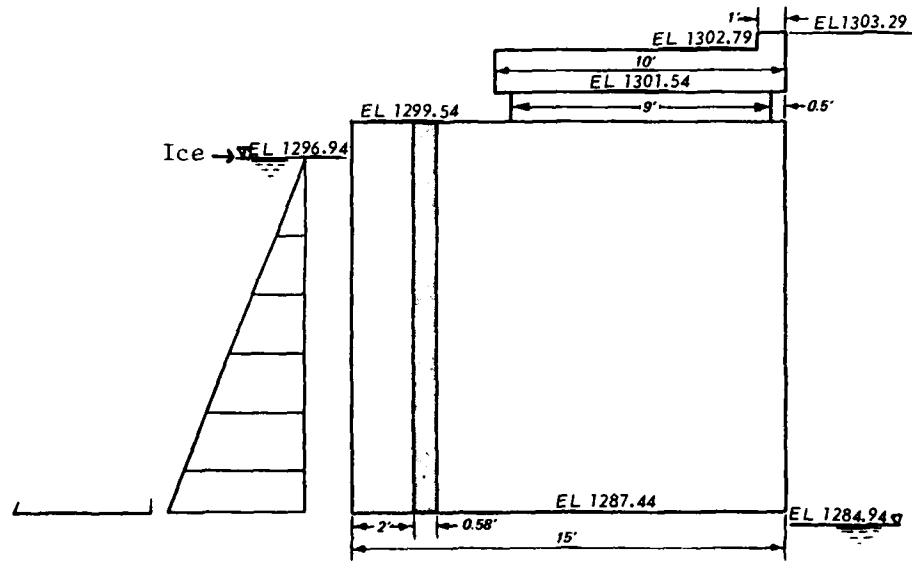

Figure 47. Normal operation with ice, Leech Lake Dam

Item	Factor	F <sub>y</sub> (kips)	F <sub>z</sub> (kips)	Arm <sub>y</sub> (ft)	Arm <sub>z</sub> (ft)	M <sub>x</sub> (ft-kip)
W <sub>Conc</sub>	From Normal Operation Calculations		160.69			1,129.3
P <sub>Headwater</sub>	$(0.0625)(1/2)(1297.94 - 1284.44)^2(11)$	-37.90			3.50	-132.6
Uplift	$(0.0625)(1297.94 - 1284.94)\left(\frac{39.5}{14.5 + 41.5 + 13}\right)(15)(5)$		-34.88	7.50		-261.6
	$(0.0625)(1/2)(1297.94 - 1284.94)\left(\frac{15}{14.5 + 41.5 + 13}\right)(15)(5)$		-6.62	10.00		-66.2
			-41.50			-327.8
e = $\frac{668.7}{119.19} = 5.61$ ft						
TOTAL		-37.90	-119.19			668.9

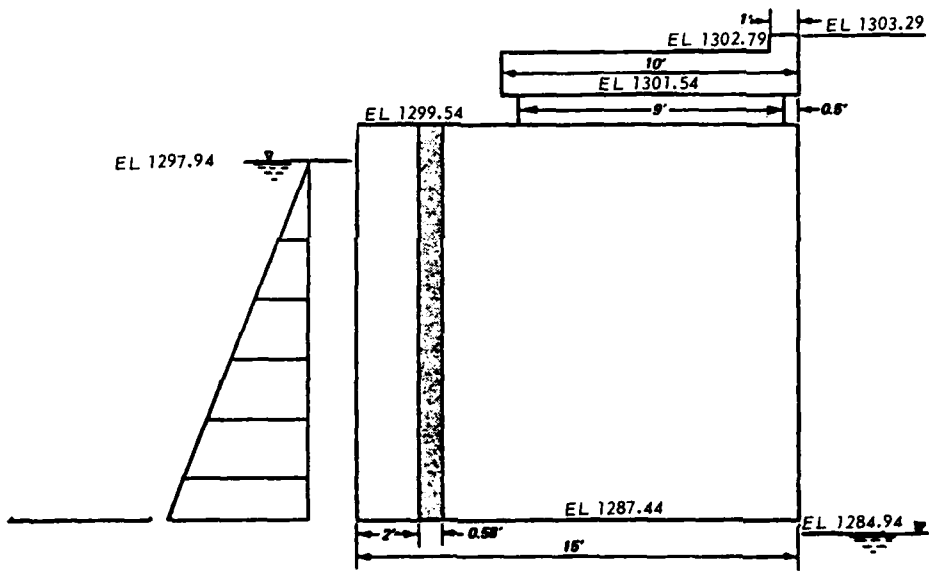

Figure 48. High-water condition, Leech Lake Dam

LOCATION OF CENTROID OF PILE GROUP FROM DOWNSTREAM END OF PIER BASE

$$\bar{Y} = \frac{2[2.42 + 6.92 + 11.67 + 14.25]}{8}$$

$$\bar{Y} = 8.82 \text{ ft}$$

MOMENT OF INERTIA OF PILE GROUP ABOUT CENTROID OF PILE GROUP

$$I = nd^2$$

$$I_{XX} = 2[(8.82 - 2.42)^2 + (8.82 - 6.92)^2 + (8.82 - 11.67)^2 + (8.82 - 14.25)^2]$$

$$I_{XX} = 164 \text{ ft}^4$$

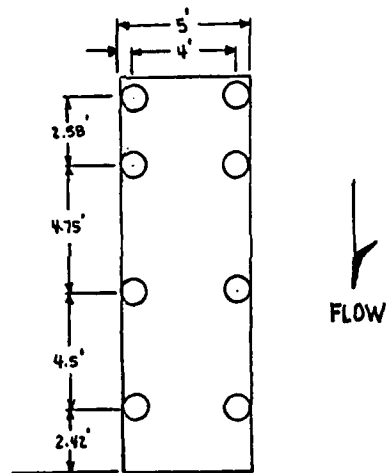

Figure 49. Moment of inertia of pile group

LEECH LAKE DAM, NORMAL OPERATION WITH ICE-MAX

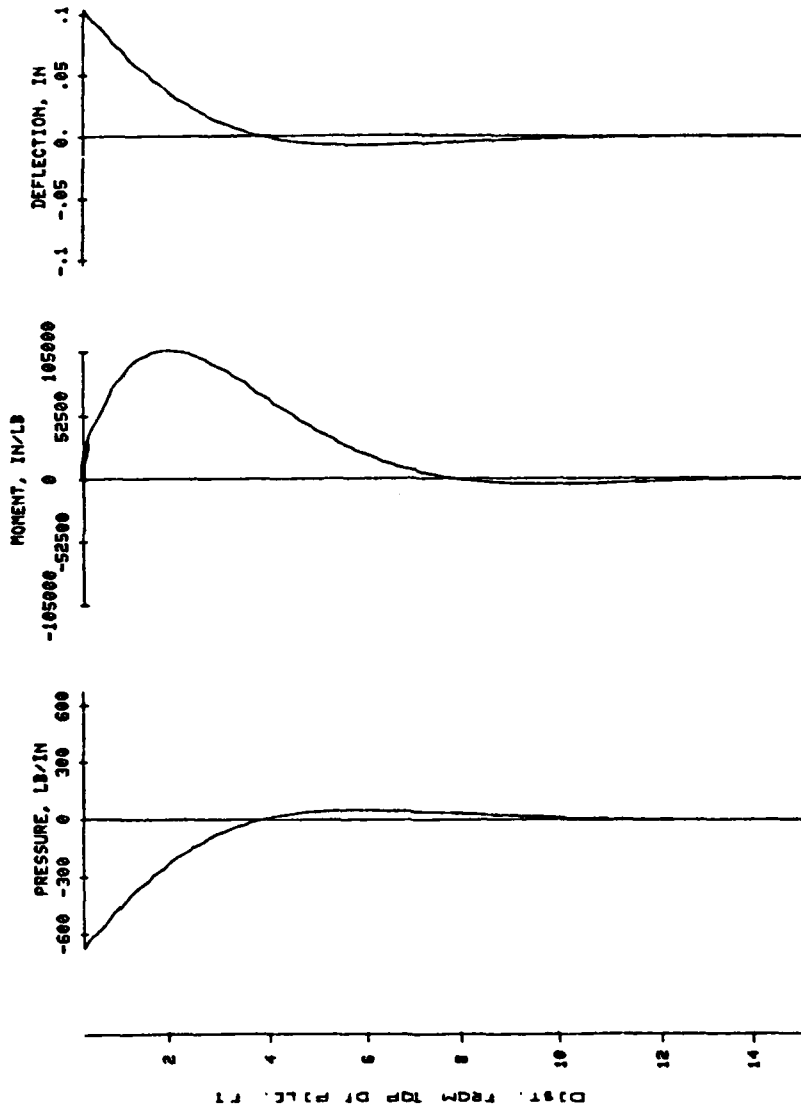

Figure 50. Pressure, moment, and deflection in the most critically loaded pile for normal operation plus ice

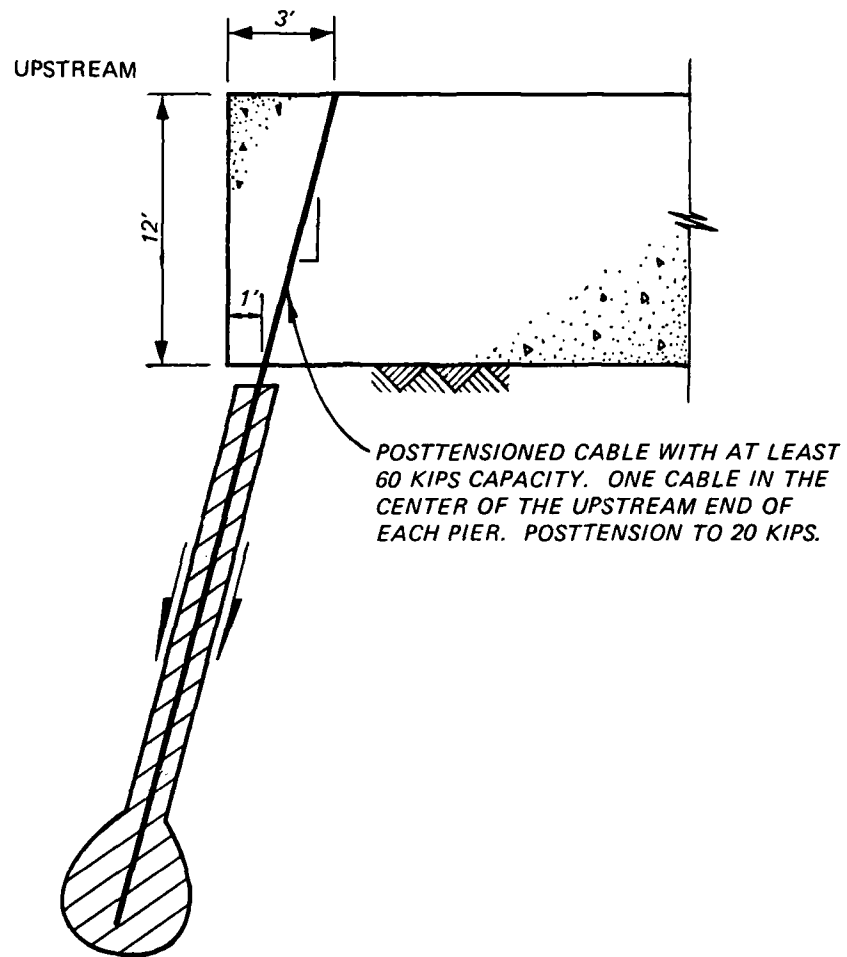

Figure 51. Posttensioning concept for soil anchor, Leech Lake Dam

Table 1  
General Reservoir Data

Location in miles above Ohio River	1244.3
Location on river	Leech Lake
Drainage area (square miles)	1163
<u>Original Operating Limits</u>	
Stage	-0.5 to 5.24 ft
Storage in 1000 acre-feet	749
<u>Present Operating Limits</u>	
Stage	0.0 to 5.24 ft
Storage in 1000 acre-feet	695
<u>Ordinary Operating Limits</u>	
Stage	0.5 to 3.0 ft
Storage in 1000 acre-feet	306
Flowage rights to stage	9 ft
Maximum stage of record (1916)	5.18 ft
Number of times upper operating limit exceeded	0
Number of times flowage limit exceeded	0
Maximum stage in 1950	4.11 ft
Maximum discharge of record and year	1675 sec-ft <sup>*</sup> 1901
Elevation of gage zero: U.S.E. datum	1293.76
Elevation of gage zero: m.s.l. (1929 adj.)	1292.70
Elevation of gage zero: m.s.l. (1912 adj.)	1293.23
Year of first operation	1884
Normal spring stage	0.5 ft
Normal summer range	1.8 to 2.2 ft

---

\* 2520 sec-ft on 7 June 1957 due to dam failure.

Table 2  
Pertinent Dam Data

<u>Dam</u>	
Type	Earth fill with timber diaphragm and crib having mixed sand-clay core
Crest elevation	1303.14
Length	3314 ft
Height	15.0+ ft
Freeboard above maximum stage	5.4+ ft
<u>Control Structure</u>	
Superstructure type	Gated multi-bay concrete sluiceway
Substructure type	Round timber bearing piles with six timber and two steel sheet-pile cut-off walls
Height of piers	11.80 ft
New width of spillway opening	162 ft
Discharge channel capacity	1500 cfs (est)
<u>Sluiceways</u>	
Number of bays	26 (including log sluice)
Number of stop log sections	21
Number of gated bays	5
Height of stop logs at normal pool (2.0 ft stage)	6.96 ft
Width of bays	6 ft
Log sluice width	12 ft.
Slide gate size	48 by 48 in.
<u>Spillway Apron</u>	
Type	18-in.-thick reinforced concrete floor with round timber bearing pile footings
Length	39 ft
Width	294 ft
Floor elevation	1287.74
<u>Bridge Over Control Structure</u>	
Type	Public walkway
Deck elevation	1302.79
Roadway width	8 ft 10 in.
Elevation of walkway	1303.54

Table 3  
Locations of Test Probe Below  
the Bottom of Each Pier

<u>Hole</u>	<u>Test</u>	<u>Probe Locations Below Bottom of Pier (ft)</u>
L-P5	1	4.12
	2	7.12
	3	10.12
L-P14	1	3.5
	2	7.5
	3	11.5
L-P24	1	4.0
	2	7.7
	3	11.7

Table 4  
Split-Spoon Test Results,  
Leech Lake Dam

<u>Hole</u>	<u>Test</u>	<u>Depth Below Bottom of Pier (ft)</u>	<u>Number of Blows</u>
L-P5	1	0.1- 0.6	2
		0.6- 1.1	2
		1.1- 1.6	2
	2	11.1-11.6	3
		11.6-12.1	6
		12.1-12.6	6
L-P14	1	0.0- 0.5	32
		0.5- 1.0	5
		1.0- 1.8	3
L-P24	1	1.1- 1.6	10
		1.6- 2.1	28
		2.1- 2.6	7
	2	12.9-13.4	3
		13.4-13.9	5
		13.9-14.4	6

Table 5  
Unconfined Compressive Concrete Strengths

<u>Core Hole</u>	<u>Specimen</u>	<u>Unconfined Compressive Strength (psi)</u>
L-P5	L-P5T	4,600
	L-P5M	7,200
	L-P5B	10,200
L-P14	L-P14T	8,200
	L-P14M	5,300
	L-P14B	7,600
L-P24	L-P24T	4,900
	L-P24M	5,900
	L-P24B	7,200

NOTE: Average value  $\approx$  6800.

Table 6  
Patching Material for Cracks,  
Spalled Joints, and Holes

<u>Material</u>	<u>Parts by Weight</u>
Cement	100
Water	~18 (adjust as needed)
Acrylic polymer	27
Fine sand (passing No. 30 sieve)	150

Table 7  
Overlay Material for  
Concrete Surface Rehabilitation

<u>Material</u>	<u>Parts by Weight</u>
Cement	100
Water	~20 (adjust as needed)
Acrylic polymer	30

Table 8  
Forces at Top of Pile by Conventional Analysis

Case Loading	Horizontal Load		Number of Piles	Horizontal Load per Pile (kips)	e (from Moment Center) (ft)	Moment About Center of Gravity of Pile Group		Moment of Inertia of Pile Group, $I_p$ (ft <sup>4</sup> )	Maximum Compressive Force Per Pile (kips)	Minimum Tensile Force Per Pile (kips)
	HL (kips)	FL (kips)				$F_y$ (kip-ft)	$F_x$ (kip-ft)			
Normal operation	31	3.88	8	3.88	5.95	-350	164	28.9	None	
Normal operation with truck loading (III-44)	31	3.88	8	3.88	5.80	-441	164	35.5	None	
Normal operation with earthquake	36	4.5	8	4.5	5.68	-383	164	30.2	None	
Normal operation with ice	86	10.75	8	10.75	1.91	-843	164	48.2	-12.66	
High-water condition	38	4.75	8	4.75	5.61	-382	164	29.8	-2.23	

Table 9  
Results of Three-Dimensional Direct Stiffness Analysis for Leech Lake Dam Piling Foundation

Load Case	Elevation of Headwater (ft)		Elevation of Tailwater (ft)	Lateral Force At Top of Pile, $F_L$ (kips)		Lateral Deflection At Top of Pile, $U_L$ (in.)	Maximum Axial Force At Top of Pile, $F_3$ (kips)		Minimum Axial Deflection At Top of Pile, $U_3$ (in.)	
	HL (ft)	FL (ft)		$F_L$ (kips)	$F_R$ (kips)		$F_3$ (kips)	$F_1$ (kips)	$U_3$ (in.)	$U_1$ (in.)
Normal operation	1298	1286	1286	3.88	3.88	0.0397	28.94	3.70	0.0045	0.0045
Normal operation with truck loading (III-44)	1298	1286	1286	3.88	3.88	0.0397	35.47	3.70	0.0045	0.0045
Normal operation with earthquake	1298	1286	1286	4.48	4.48	0.0459	30.23	2.61	0.0032	0.0032
Normal operation with ice	1298	1286	1286	10.75	10.75	0.1100	48.18	-12.65	-0.0155	-0.0155
High-water condition	1299	1286	1286	4.74	4.74	0.0485	29.76	2.27	0.0028	0.0028

In accordance with letter from DAEN-RDC, DAEN-ASI dated 22 July 1977, Subject: Facsimile Catalog Cards for Laboratory Technical Publications, a facsimile catalog card in Library of Congress MARC format is reproduced below.

Pace, Carl E.

Structural stability evaluation Leech Lake Dam : final report / by Carl E. Pace (Structures Laboratory, U.S. Army Engineer Waterways Experiment Station). -- Vicksburg, Miss. : The Station ; Springfield, Va. : available from NTIS, [1981].

29, [41] p. : ill. ; 27 cm. -- (Miscellaneous paper / U.S. Army Engineer Waterways Experiment Station ; SL-81-22)

Cover title.

"September 1981."

"Prepared for U.S. Army Engineer District, St. Paul under Intra-Army Order No. NCS-1A-78-75."

Bibliography: p. 29.

1. Concrete dams. 2. Leech Lake Dam (Minn.)  
3. Structural stability. I. United States. Army.  
Corps of Engineers. St. Paul District. II. U.S.

Pace, Carl E.

Structural stability evaluation Leech Lake Dam : ... 1981.  
(Card 2)

Army Engineer Waterways Experiment Station. Structures  
Laboratory. III. Title IV. Series: Miscellaneous  
paper (U.S. Army Engineer Waterways Experiment Station) ;  
SL-81-22.

TA7.W34m no.SL-81-22