

VEH # BS

REPORT DOCUMENTATION PAGE

READ INSTRUCTIONS BEFORE COMPLETING FORM

2

1. REPORT NUMBER

TOP-4-2-830

2. GOVT ACCESSION NO.

AD-A104838

3. RECIPIENT'S CATALOG NUMBER

4. TITLE (and Subtitle)

US Army Test and Evaluation Command  
Test Operations Procedure  
Explosive Cratering Performance Tests

5. TYPE OF REPORT & PERIOD COVERED

Final rept. on test

6. PERFORMING ORG. REPORT NUMBER

Operations procedur

7. AUTHOR(s)

8. PERFORMING ORGANIZATION NAME AND ADDRESS

US Army Tropic Test Center  
ATTN: SIETC-MTD  
APO Miami 34004

10. PROGRAM ELEMENT, PROJECT, TASK AREA & WORK UNIT NUMBERS

DARCOM-R 310-6

9. CONTROLLING OFFICE NAME AND ADDRESS

US Army Test and Evaluation Command  
ATTN: DRSTE-AD-M  
Aberdeen Proving Ground, MD 21005

12. REPORT DATE

2 July 1981

13. NUMBER OF PAGES

73

4. MONITORING AGENCY NAME & ADDRESS (if different from Controlling Office)

15. SECURITY CLASS. (of this report)

Unclassified

15a. DECLASSIFICATION/DOWNGRADING SCHEDULE

12 74

16. DISTRIBUTION STATEMENT (of this Report)

Approved for public release; distribution unlimited.

DTIC  
ELECTE  
OCT 1 1981

17. DISTRIBUTION STATEMENT (of the abstract entered in Block 20, if different from Report)

A

18. SUPPLEMENTARY NOTES

81 9 30 074

19. KEY WORDS (Continue on reverse side if necessary and identify by block number)

Crater Volume Calculations  
Cratering  
Field Data Analyses  
Methodology

Mobility Implications  
Site Parameters  
Test Operations Procedure  
Tropic Test Center

20. ABSTRACT (Continue on reverse side if necessary and identify by block number)

This test operations procedure (TOP) establishes procedures for conducting field tests to measure and evaluate the cratering performance of chemical explosives and munitions. Methods for predicting explosive performance and for determining optimum charge weights and placements are provided. These methods are based upon crater volumes for trinitrotoluene (TNT), and include conversion procedures for ammonium nitrate (AN) and blasting agent (BA) explosives.

AD A104838

FILE COPY

041750

[Faint, mostly illegible text and markings, possibly including a circular stamp on the left side of the page.]

US ARMY TEST AND EVALUATION COMMAND  
TEST OPERATIONS PROCEDURE

DRSTE-RP-702-103

2 July 1981

Test Operations Procedure 4-2-830

AD No.

EXPLOSIVE CRATERING PERFORMANCE TESTS

		<u>Page</u>
Paragraph 1.	SCOPE . . . . .	1
1.1	Performance Testing . . . . .	1
1.2	Associated Procedures . . . . .	2
1.3	Mobility Implications . . . . .	2
2.	FACILITIES AND INSTRUMENTATION . . . . .	3
2.1	Facilities . . . . .	3
2.2	Instrumentation . . . . .	3
3.	PREPARATION FOR TEST . . . . .	5
3.1	Facilities . . . . .	5
3.2	Instrumentation . . . . .	6
3.3	Test Item . . . . .	6
3.4	Equipment . . . . .	6
3.5	Data Required . . . . .	7
4.	TEST CONTROLS . . . . .	7
4.1	Control Concept . . . . .	7
4.2	Control Procedures . . . . .	7
5.	PERFORMANCE TESTS . . . . .	8
5.1	Overview . . . . .	8
5.2	Method . . . . .	9
5.3	Data Required . . . . .	19
6.	DATA REDUCTION AND PRESENTATION . . . . .	20
Appendix A	Checklists . . . . .	A-1
B	Data Collection Sheets . . . . .	B-1
C	Calculations . . . . .	C-1
D	Cratering Definitions . . . . .	D-1

1. SCOPE.

1.1 Performance Testing

a. This test operations procedure (TOP) establishes procedures for conducting field tests to measure and evaluate the cratering performance of chemical explosives and munitions. Procedures for predicting explosive performance and for determining optimum charge weights and placements are included for crater design purposes and for use as analytical tools.

Approved for public release; distribution unlimited.

b. The predictive methods included herein are based upon calculation of crater volumes for trinitrotoluene (TNT), and conversion of these volumes to the associated crater volumes for ammonium nitrate (AN) and blasting agent (BA). Cratering performance data are more comprehensive for TNT than for other explosives. Additional research which integrates data regarding charge size, type, and emplacement locations into the evaluation process is required to predict the performance of non-TNT explosives.

c. Data collection and analysis procedures apply to performance testing of a single explosive, as well as to comparison tests of more than one explosive type. Data reduction and analysis procedures are based upon TNT, AN, and BA comparison tests conducted at the US Army Tropic Test Center.<sup>1</sup>

d. Procedures for explosive cratering of paved roads and bridge destruction will be found in a US Army Test and Evaluation Command (TECOM) TOP, to be scheduled for development.

### 1.2 Associated Procedures

Procedures outlined in this TOP are limited to those required for explosive performance subtests. Additional subtests which may be required by test planning documents are listed below with associated references:

a. Safety: TOP 4-1-001, Testing Ammunition and Explosives; TOP 4-2-502, Safety Evaluation of Mines and Demolitions; TOP 4-2-505, Mines and Demolitions; TOP 6-2-507, Safety; and TOP 10-2-508, Safety and Health Hazard Evaluation—General Equipment.

b. Receipt Inspection: TOP 8-2-50C, Receipt Inspection; and TOP 10-2-211, Packaging and Containers.

c. Training and Human Factors: TOP 1-2-610, Human Factors Engineering, Part I—Test Procedure, Part II—Human Factors Engineering Data Guide for Evaluation (HEDGE).

d. Storage: TOP 1-1-051, Ammunition and Explosives.

### 1.3 Mobility Implications

a. A primary objective of cratering tests is evaluation of an explosive's ability to form craters which are effective barriers to vehicle mobility. Procedures to assess limitations of combat vehicle mobility are provided in the US Army Mobility Model.<sup>2</sup>

<sup>1</sup> Final Report of Development Test II (Prototype Qualification Test—Government) of Demolition Kit, Blasting: XM268, TECOM Project No. 8-MU-011-000-006, February 1980.

<sup>2</sup> The Army Mobility Model, US Army Waterways Experiment Station (USAWES), US Army Tank-Automotive Command (TACOM), and Stevens Institute of Technology, TACOM Tr. No. 11921, May 1975.

b. Terrain factors which influence explosive performance affect vehicle mobility as well. Terrain data requirements are addressed in paragraph 5.2.3, Data Required.

## 2. FACILITIES AND INSTRUMENTATION.

### 2.1 Facilities

Testing and safety requirements outlined in test planning documents determine whether a specific test area is suitable for cratering tests. Cratering test areas must meet the terrain conditions outlined below, as well as safety and security requirements.

<u>ITEM</u>	<u>REQUIREMENT</u>
Cratering Test Area	Smooth, level (< 2 percent slope) area, either bare or covered with short grass. Soil should be uniform in type and depth. Avoid areas with bed-rock near the intended charge depth and those containing rocks or boulders. Avoid sloping, irregular surfaces. (NOTE: The degree of slope will have a large influence on the shape and size of craters. If a sloping site must be used, the center of charge depth must be measured perpendicular to the surface.)

### 2.2 Instrumentation

Instrumentation and equipment requirements are listed below:

<u>ITEM</u>	<u>REQUIREMENT</u>
<u>Instrumentation</u>	<u>Range/Minimum Accuracy</u>
Aiming level or surveyor's transit	Standard
Surveying rod	Standard; English or metric units
Steel measuring tapes	50 ft (15.2 m) and 100 ft (30.5 m)
Cone penetrometer	300 psi (2,068,427.1 Pascal), ± 10%
Soil moisture/density sampler	2-in (5 cm) diameter, thin-walled sampler
Rain gauge, weighing rain bucket	± 0.1 in (± 0.25 cm)
Sling psychrometer	± 1%, ± 1°C

<u>ITEM</u>	<u>REQUIREMENT</u>
<u>Instrumentation</u>	
Wind indicator	Speed $\pm$ 2 mph ( $\pm$ 3.2 km/h); direction $\pm$ 5°
Weighing scale	100 lb, $\pm$ 0.01 lb (45 kg, $\pm$ 4.5 g)
Chemical laboratory instrumentation	Component analysis $\pm$ 0.1% accuracy
Soils laboratory instrumentation	Soils identification, moisture/density determination according to ATSM standards.
Sound level meter	Sensitive diameter of transducer $\leq$ 4 mm
<u>Equipment (explosive/site preparation)</u>	
Mortar box/plastic garbage can	To contain explosive slurry components during manual mixing
Wooden paddle	To mix explosive slurry components manually
Concrete mixer*	To mix explosive slurry components mechanically
Grout pump	To transfer mixed slurry into charge locations mechanically
Plastic bags	To contain explosive slurry charges
Booster charges and detonator cord	As required by explosive type
Blasting caps/machines	To initiate charge; electric or nonelectric
Wooden stakes	2 in x 2 in x 48 in per stake
Steel blast shield	To protect personnel from blast wave and ejecta; $\geq$ 1/2 in thickness
<u>Equipment (excavation)</u>	
Portable earth auger	To dig hole for single charge emplacement; two-person, hand-held
Shaped charges	To blast holes for single charge emplacement; 15- or 40-lb
Backhoe	To dig trench for multiple charge or horizontal pipe/trench charge emplacement

<u>ITEM</u>	<u>REQUIREMENT</u>
<u>Equipment (personal protective)</u>	
Ear plugs	To protect personnel from blast noise and over-pressure
Gloves and aprons	To protect personnel from slurry components during mixing
Hard hats	To protect personnel from crater ejecta

\* A safety release must be provided by the supplier prior to bulk mixing explosive slurry in a concrete mixer.

### 3. PREPARATION FOR TEST.

#### 3.1 Facilities

3.1.1 Test Areas. Cratering tests involve formation of craters by explosives such as TNT, standard Army (ammonium nitrate— $\text{NH}_4\text{NO}_3$ ) cratering charges, field-mixed bulk explosives (slurry), or demolition kits. Whenever possible, specific crater sites should have zero slope and consist of grassland or bare ground which is free of timber and brush. This combination of characteristics will enhance test result repeatability.

3.1.2 Test Area Selection Parameters. In addition to minimum slope and absence of brush and timber, an optimum test area contains homogeneous soil types with virtually identical depth, to allow for constant charge burial depths. History of prior excavation or disturbance among the various crater sites within the test area should be comparatively equal. However, if land having zero slope is not available, select an area that will permit emplacement of the maximum number of charges in soil with equivalent crater site slopes. Thus, as differences among crater sites are minimized, the probability of finding consistent relationships among cratering parameters is maximized.

a. Select a test area that meets the requirements of paragraph 2.1, above, and complies with pertinent range restrictions. Obtain soil samples at several locations in the proposed area. If soil depth and soil type profiles are similar at the various sample locations, the area is suitable for cratering tests. The test area must be large enough to accommodate the required number of detonations without affecting individual cratering performance.

2 July 1981

b. Prepare a sketch showing individual test site locations within the test area, and identify the measurement axes for each crater; e.g., north, south, east, and west axes.

c. Establish a safe area in which test personnel will be protected from ejecta and noise at detonation. Minimum safe distances, determined by charge weight, are listed in FM 5-25.<sup>3</sup> Failure to take cover before detonation can result in injuries from ejecta and/or sound.

3.1.3 Before initiating the active test phase, calculate predicted crater diameters, depths, and volumes for each explosive type and for each charge weight. Volume prediction procedures are listed in Appendix C, paragraph 1.

### 3.2 Instrumentation

a. Select appropriate instrumentation from that listed in paragraph 2.2. Insure that valid calibration has been accomplished for those items requiring it.

b. Check instrument positioning (e.g., transit leveling) and calibration during active test phases.

### 3.3 Test Item

a. Procure a quantity of each explosive type sufficient to complete the test. To minimize the effect of lot differences upon test results, obtain explosives from the smallest number of production lots possible. If explosives from more than one production lot must be used, randomize charge selection for specific test sites. Use equal charge weights and equivalent primer placements for control and test charges to insure comparability of test results.

b. Before, during, and after active testing, send randomly selected samples of test and control explosives to the chemical laboratory for assessment of possible changes in chemical composition.

### 3.4 Equipment

a. Insure that personal safety equipment is available at the test area and is used during active test phases.

b. When tests require mixing of explosive slurry components, provide personnel with items such as gloves and aprons to prevent slurry components from splashing onto clothing or exposed skin.

<sup>3</sup> FM 5-25, Explosives and Demolitions, February 1971.

2 July 1981

TOP 4-2-830

c. Provide hearing protection equipment as stipulated by MIL-STD-1474B (MI),<sup>4</sup> paragraph 52, and TB MED 251.<sup>5</sup>

d. Provide protection from crater ejecta by issuing steel helmets (hard hats), erecting steel blast shields, or using vehicles as temporary blast shields.

### 3.5 Data Required

a. Prepare a separate data collection sheet for each crater site (forms B-1 through B-5, Appendix B). The following data are required before actual testing begins:

- (1) Test site identification (crater number, grid coordinates).
- (2) Preliminary soil classification.

b. Obtain standard weather records (mean daily ambient temperature, relative humidity, rainfall) from the nearest weather station for a 30-day period prior to the active test phase.

## 4. TEST CONTROLS.

### 4.1 Control Concept

Evaluation of explosive performance is accomplished by comparing the results of test and control sample detonations. To prevent biased test results, control sample integrity must be maintained and field procedures must be strictly controlled. Test results must be accurate and reproducible.

### 4.2 Control Procedures

a. Randomize selection of samples for chemical analysis and charge emplacement. Consult a statistician to determine randomization techniques for the following:

- (1) Sample selection from more than one materiel lot.
- (2) Sample allocation (control and exposed sample selection).
- (3) Laboratory testing of samples (control and exposed samples).

b. Repeat all measurements for the first and several randomly chosen craters to determine if surveying procedures are providing accurate measurements. Perform field volume calculations (Appendix B, paragraph 3) for each

<sup>4</sup> MIL-STD-1474B (MI), Noise Limits for Army Materiel, 18 June 1979.

<sup>5</sup> TB MED 251, Noise and Conservation of Hearing, 7 March 1972.

2 July 1981

set of measurements. If variance among calculated volumes indicates that accuracy is insufficient, review surveying procedures to determine if they are correct. Repeat measurements until accuracy is achieved. Report the average crater volume for those crater sites where repeated measurements are taken. Time constraints will limit the number of sites which can be measured more than once, as well as the number of measurements which can be repeated at a given site.

c. Before, during, and after active testing, send randomly selected samples of test and control explosives to the chemical laboratory for assessment of possible changes in chemical composition.

d. Randomize the order of firing to minimize the effects of terrain features (e.g., moisture, subterranean rocks, root systems, et.al.) and other factors on test results.

## 5. PERFORMANCE TESTS.

### 5.1 Overview

a. Performance tests are the primary means of evaluating the effect of the environment upon the test item. Effects of environmental exposure, if any, will appear during performance tests. Therefore, it is important that test personnel follow specific test procedures. Test checklists which detail step-by-step procedures should be developed for each cratering method (Appendix A).

b. For testing purposes, assessment of cratering performance is defined as the determination of the volume of soil excavated from a crater by an explosive.

c. Mission requirements outlined in test planning documents determine which test procedure to use: Single-charge cratering, paragraph 5.2.1; five-charge row cratering (2 to 7 charges), paragraph 5.2.3; or multiple-charge row cratering (8 or more charges), paragraph 5.2.2.

d. Whenever possible, fire test explosives by remote control, using electric blasting caps.<sup>6</sup>

---

<sup>6</sup> Electric firing systems should not be used in areas where electrical storms, radio frequency signals, or power transmission lines can cause premature detonations. Minimum safe distances from power transmission lines and transmitter antennas are listed in FM 5-25.

e. Designate a survey team to gather measurement data. To obtain the most accurate measurements, select five individuals to perform the following tasks:

- (1) Operate the aiming level or surveyor's transit—one person.
- (2) Handle the surveying rod—one person.
- (3) Record measurement data—one person.
- (4) Handle steel measuring tapes—two persons.

f. Repeat measurements for the first and several randomly selected craters to check data accuracy, using procedures outlined in paragraph 4.2b, above.

g. Insure that all personnel participating in field tests have been trained to at least the minimum degree specified in test planning documents.

h. Reduce the number of persons exposed to test hazards to a minimum. Keep exposure periods as brief as possible.

i. Before detonating explosives, check meteorological conditions to insure that weather-related blast effects (e.g., blast waves ricocheting from low cloud cover) will not damage nearby structures or injure troops in another part of the firing range.

## 5.2 Method

### 5.2.1 Single-Charge Cratering

#### a. Predetonation Procedures

(1) Establish crater site. Prepare charge hole at site ground zero. Normally, the charge hole diameter is determined according to charge size. However, test planning documents may specify the diameter, as well as the charge hole depth. Charge depths for standard explosives applications are listed in FM 5-25. Procedures for determining optimum charge burial depth according to charge weight are in Appendix C, paragraph 1.

(2) Record charge hole diameter, depth, and method of preparation (i.e., drilled with earth auger or blown with shaped charge) on the single-charge crater data collection sheet (form B-3).

2 July 1981

(3) Establish four radii from ground zero. Placing one radius at each cardinal point will simplify surveying procedures (figure 1).

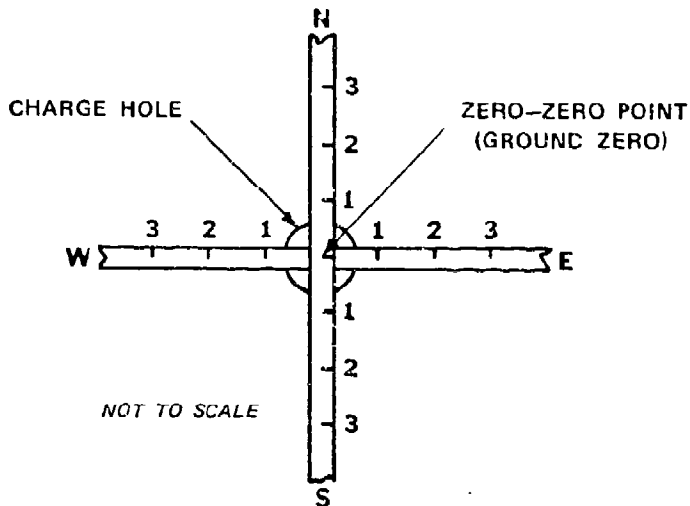

Figure 1. Measurement Orientation.

(4) Measure to a point on each radius that is sufficiently distant from ground zero to be free from disturbance by the blast. Emplace a stake at that point. For example, if the test requires detonation of 40-pound (18.1 kg) and 200-pound (90.7 kg) charges, emplace radius stakes 40 feet (12.2 m) and 100 feet (30.5 m) from ground zero, respectively. Stakes must protrude at least 2 1/2 feet (0.8 m) above the ground.<sup>7</sup>

(5) Record each radius stake's distance and direction from ground zero on form B-3.

(6) After radius stakes have been emplaced, connect steel measuring tapes to them, running east to west and north to south. Use tapes marked in 1-foot (0.3 m) increments as follows: 40 feet, 39 feet, 38 feet, . . . 0 feet, 1 foot, 2 feet, 3 feet, . . . 40 feet. When tapes are fastened to radius stakes at the increment corresponding to the stake's distance from ground zero (e.g., 40 feet (12.2 m) for a 40-pound (18.1 kg) and 100 feet (30.5 m) for a 200-pound (90.7 kg) charge, the zero point on each tape will be aligned over the charge hole's center; i.e., ground zero (figure 1). Attach tapes to the stakes 2 feet (0.6 m) above the ground. Tapes should be held as straight and level as possible.

(7) Position the measuring instrument (aiming level or surveyor's transit) in a central location for measuring all four radii. Record instrument height on the elevation profile data collection sheet (form B-1). Place a reference stake under the surveying instrument to aid in repositioning it for postdetonation measurements.

<sup>7</sup> Use volume prediction procedures in Appendix C, paragraph 1, to determine the predicted length of crater radii. Radius stakes must be placed well beyond the predicted radius. Confirm distances by preliminary testing. If stake placement is affected by blast, emplace stakes for subsequent craters at empirically determined distances sufficient to preclude disturbance.

(8) Select an existing terrain feature to establish as a bench mark, and record its elevation on form B-1.

(9) Using a surveying rod, measure the vertical distance from line-of-sight (instrument) to the ground along the entire length of the north to south and east to west lines. Take rod readings at horizontal increments of 3 feet (0.9 m) on flat terrain. If terrain is irregular, take readings at 1-foot (0.3 m) horizontal increments. The surveying rod should be held as vertical as possible. Record rod readings on form B-1.

(10) Plot unusual terrain features such as hills, cuts, or depressions at actual location (not necessarily at exact measurement increments), and record rod readings on form B-1.

(11) Measure elevations at the four radius stakes. Determine strike of slope and slope compass azimuth. Record these data on form B-3.

(12) Check instrument leveling before, during, and after the measurement process to minimize errors.

(13) Obtain soil strength and moisture data at selected points along the north to south and east to west lines. Collect bulk soil samples for laboratory determination of soil type. Record these data on the soil measurements data collection sheet (form B-5).

(14) Upon completion of predetonation measurements, remove the measuring tapes and measuring instrument, leaving radius stakes in place.

#### b. Charge Emplacement and Detonation

(1) Place prepared explosive in charge hole. Follow guidance in test planning documents, FM 5-25, and FM 5-34<sup>6</sup> for priming and stemming charges.

(2) Explosives should be prepared and emplaced by personnel possessing a 12B (combat engineer) military occupational specialty (MOS). Explosive ordnance personnel should supervise preparation and emplacement activities and dispose of leftover explosives.

(3) Record the following information on form B-3:

(a) Depth of charge hole and distance from top of charge to top of charge hole.

(b) Explosive type and charge weight.

---

<sup>6</sup> FM 5-34, Engineer Field Data, 24 September 1976.

- (c) Booster and primer types and locations in charge hole.
  - (d) Detonation cord type and position.
  - (e) Charge hole condition (stemmed or unstemmed). If stemmed, specify with what (spoil or water).
  - (f) Firing system (electric or nonelectric).
  - (g) If a field-mixed explosive is used, record time required to mix components and elapsed time between mixing and detonation (gel time).
- (4) Clear crater site and insure that personnel have moved to the designated safe area. Detonate charge. Record time of detonation on form B-3.
- (5) Observe detonation and record subjective evaluation of fireball intensity on form B-3.
- (6) Record on form B-3 relative humidity, wind speed and direction, and temperature during detonation.
- (7) Crater features are shown in figure 2.

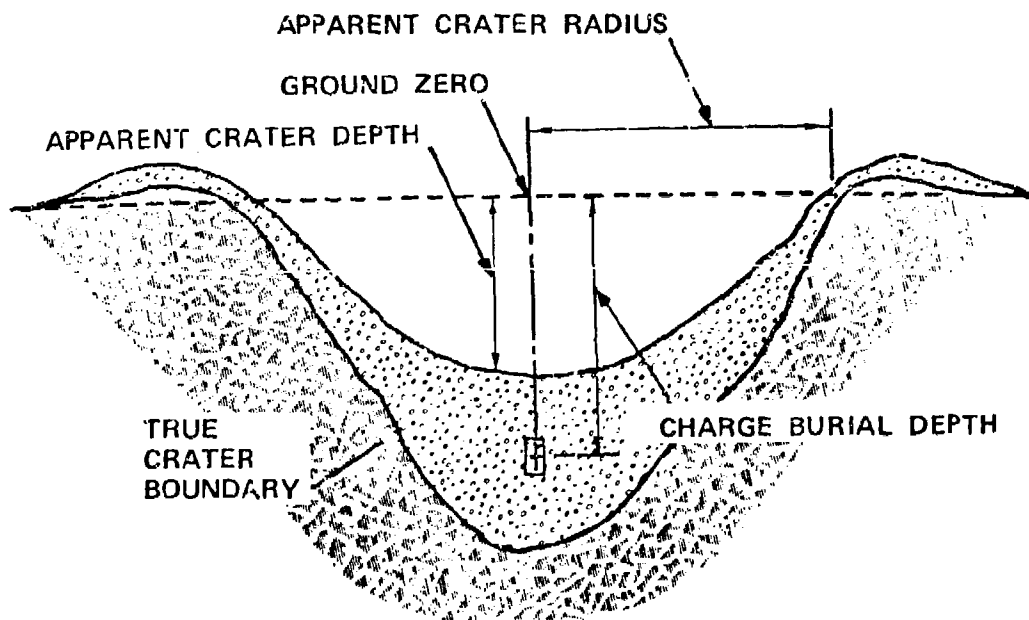

Figure 2. Cross Section of a Single-Charge Crater.

## c. Postdetonation Procedures

(1) After detonation, reposition the measuring instrument and tapes for postdetonation measurements. Place the instrument as close as possible to its predetonation location.

(2) Obtain instrument height from the bench mark and record it on form B-1. The difference between pre- and postdetonation instrument heights is applied to each vertical distance measurement as a correction factor when performing volume calculations. (NOTE: Use a separate form B-1 for pre- and postdetonation measurements.)

(3) Identify original ground level at the edge of the ejecta. Following procedures outlined in paragraphs 5.2.1a(9), (10), and (12), above, obtain rod readings to edge of the ejecta, original ground level, or radius stake, whichever is located first. Record rod readings on form B-1.<sup>9</sup>

(4) Locate the apparent crater wall by removing ejecta from the crater perimeter until the original ground surface is identified. Presence of ground cover, difference in soil color, moisture variation, etc., indicate that the original ground surface has been reached. Measure distance from the apparent crater wall to ground zero (zero-zero point on measuring tapes) and record it on form B-1.

(5) If the person handling the surveying rod cannot read the measuring tape while standing in the crater, loosen the tape so the rod handler can identify his/her lateral position. Then, reapply tension to the tape so the handler can find the next rod reading location.

(6) Record descriptions and measurements of crater ejecta on form B-3. Include distance from ground zero, geometric shape, dimensions, and descriptions for the following types of ejecta:

(a) Ejecta at given distances from ground zero (e.g., 100 feet (30.5 m), 200 feet (61 m)).

(b) Largest discrete ejecta (clods).

(c) Typical ejecta.

(7) Obtain postdetonation soil measurements and record them on form B-5.

(8) After collecting measurement data, calculate the crater's approximate volume, following procedures in Appendix C, paragraph 3, for crater volume calculations in the field. Use the form for field volume calculations (form

<sup>9</sup> Explosive charge weight and equipment availability determine the horizontal increment between depth measurements. Analyze data on the basis of integer distances between depth measurements. When noninteger distances are used as measurement intervals, obtain crater volume (ft<sup>3</sup>(m<sup>3</sup>)) by using the appropriate conversion factor after volumes are calculated.

B-2) to complete calculations. Compare this volume with the predicted volume to assess predictive accuracy.

(9) Before giving data collection sheets to data analysts for volume calculations, and while still at the test site, review data for errors.

### 5.2.2 Multiple-charge Row Cratering—General

#### a. Predetonation Procedures

(1) Establish test site. Determine the charge weights, burial depths, and spacing required to produce a row crater of the desired size.<sup>10</sup>

(2) Prepare charge holes in accordance with established crater design. Record each charge hole's diameter, depth, and method of preparation on the multiple-charge row crater data collection sheet (form B-4).

(3) Following volume prediction procedures in Appendix C, paragraph 1, predict the diameter of craters which will be formed by single charges at each end of the charge row.

(4) Add the predicted diameters to the distance between the first and last charge burial locations. This sum provides the length of the section to be surveyed before detonation and defines longitudinal axis length. Survey section width is equivalent to two predicted diameters.

(5) Establish cross-sectional radii which bisect the longitudinal axis at right angles. Each radius should extend to either side of the longitudinal axis the equivalent of one predicted crater diameter. Locate radii on the longitudinal axis as follows:

(a) Establish one radius midway between the two end charges.

(b) Measure inward from each end charge to a point which is approximately 20 percent of the charge row length. Establish a radius over the charge holes nearest to these points.

(6) For example, cross-sectional radii for a 12-charge row crater would be established as follows (figure 3):

(a) Prepare 12 charge holes spaced 5 feet (1.5 m) apart (center to center) on a straight line. This results in a charge row length of 55 feet (16.8 m). For the purpose of this example, assume that the predicted diameter for each end charge is 40 feet (12.2 m). Add the predicted crater diameter to each end of the charge row. Add a 10-foot (3.5 m) safety margin to each end of the charge row to allow for predictive error. The total length of the longitudinal axis is now 155 feet. The first charge is located at the 50-foot (15.2 m) point on the longitudinal axis.

<sup>10</sup> Normally, test planning documents will specify crater design requirements. Additional row crater design requirements are contained in FMs 5-25 and 5-34.

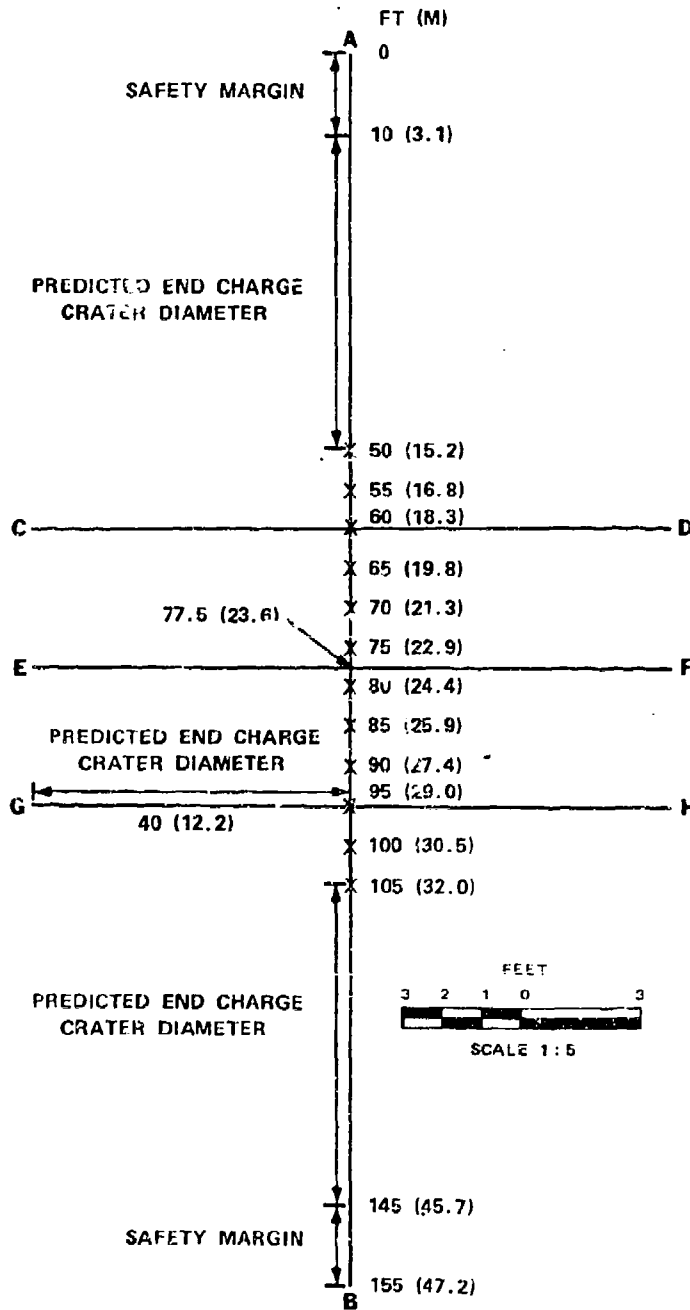

Figure 3. Cross-sectional Radii Locations for Twelve-charge Row Crater.

b. Establish a radius at the 77.5-foot (23.6 m) point on the longitudinal axis (center of charge row). Radius should bisect longitudinal axis at right angles and extend 40 feet (12.2 m) in each direction (predicted end charge crater diameter).

(c) Establish similarly oriented radii over charge holes at the 60- and 95-foot (18.3 and 29 m) points on the longitudinal axis (approximately 20 percent of charge row length inward from end charges).

(7) Place stakes protruding at least 2 1/2 feet (0.8 m) from the ground at each end of all three radii and at each end of the longitudinal axis. Stakes must be emplaced securely to withstand blast effects.

(8) Using steel measuring tapes, connect the two stakes on each radius in a straight line. Connect the two stakes on each end of the longitudinal axis as will, using a steel measuring tape to form a line dissecting the three radii at right angles. Attach tapes to stakes 2 feet (0.6 m) above the ground. Tapes should be held as straight and level as possible.

(9) Position the measuring instrument (aiming level or surveyor's transit) so that all radius and axis stakes can be seen. Record instrument height on form B-1. Place a reference stake under the surveying instrument to aid in repositioning it for postdetonation measurements.

(10) Select an existing terrain feature to establish as a bench mark, and record its elevation on form B-1.

(11) Record these data on form B-4.

(a) Longitudinal axis azimuth and length.

(b) Distance and direction of radius stakes from longitudinal axis.

(c) Elevation of all radius and axis stakes.

(d) Strike of slope and slope compass azimuth.

(12) Assign radius/axis stakes a letter identifier. Using a surveying rod, measure the vertical distance from line-of-sight (instrument) to the ground along the entire length of each radius and the longitudinal axis. Using the example in paragraph 5.2.2a(6), above, rod readings would be taken between points A to B, C to D, E to F, and G to H, as shown in figure 3. Take rod readings at 3-foot (0.9 m) intervals on flat terrain. If terrain is irregular, measure at 1-foot (0.3 m) horizontal intervals. The surveying rod should be held as vertical as possible. Record rod readings on form B-1.

(13) Plot unusual terrain features at actual location (not necessarily at exact measurement increments). Record rod readings on form B-1.

(14) Check instrument leveling before, during, and after the measurement process to minimize errors.

(15) Obtain soil strength and moisture data at selected points along each radius and the longitudinal axis. Record these data on form B-5. Collect bulk soil samples for laboratory determination of soil type.

(16) Upon completion of predetonation measurements, remove the steel measuring tapes and measuring instrument, leaving radius and axis stakes in place.

#### b. Charge Emplacement and Detonation

(1) Place prepared explosives in charge holes. Follow guidance in test planning documents, FM 5-25, and FM 5-34 for priming and stemming charges.

(2) Explosives should be prepared and emplaced by personnel possessing a 12B (combat engineer) MOS. Explosive ordnance personnel should supervise preparation and emplacement activities and dispose of leftover explosives.

(3) Record the following information on form B-4:

(a) Depth of charge holes and distance from top of each charge to top of each charge hole.

(b) Explosive type and charge weight for each charge hole.

(c) Booster and primer types and locations in charge holes.

(d) Detonation cord type and position.

(e) Condition of charge holes (stemmed or unstemmed). If stemmed, specify with what (spoil or water).

(f) Firing system (electric or nonelectric).

(g) If field-mixed explosives are used, record time required to mix components and elapsed time between mixing and detonation (gel time).

(4) Clear crater site and insure that personnel have moved to the designated safe area. Detonate charges. Record time of detonation on form B-4.

(5) Observe detonation and record subjective evaluation of fireball intensity on form B-4.

(6) Record on form B-4 relative humidity, wind speed and direction, and temperature during detonation.

#### c. Postdetonation Procedures

(1) After detonation, reposition the measuring instrument and tapes for postdetonation measurements. Place the instrument as close as possible to its predetonation location.

(2) Obtain instrument height from the bench mark and record it on form B-1. The difference between pre- and postdetonation instrument heights is applied to each vertical distance measurement as a correction factor when performing volume calculations. (NOTE: Use a separate form B-1 for pre- and postdetonation measurements.)

(3) Identify original ground level at the edge of the ejecta. Following procedures in paragraphs 5.2.2a(12) through (14), above, obtain rod readings to edge of the ejecta, original ground level, or radius/axis stake, whichever is located first. Record rod readings on form B-1.

2 July 1981

(4) Locate the apparent crater wall by removing ejecta from the crater perimeter until the original surface is identified. Presence of ground cover, difference in soil color, moisture variation, etc., indicate that the original ground surface has been reached. Measure distance from the apparent crater wall to the longitudinal axis and record it on form B-4.

(5) If the person handling the surveying rod cannot read the measuring tape in the crater, loosen the tape so the rod handler can identify his/her lateral position. Then, apply tension to the tape so the rod handler can find the next rod reading location.

(6) Record descriptions and measurements of crater ejecta on form B-4. Include distance from each radius and axis stake, geometric shape, dimensions, and descriptions for the following types of ejecta:

(a) Ejecta at given distances from the longitudinal axis (e.g., 100 feet (30.5 m), 200 feet (61 m)).

(b) Largest discrete ejecta (clods).

(c) Typical ejecta.

(7) Obtain postdetonation soil measurements and record them on form B-5.

(8) After collecting measurement data, calculate approximate crater volume, following procedures in Appendix C, paragraph 3, for crater volume calculations in the field. Use form B-2 for field calculations. Compare this volume with the predicted volume to assess predictive accuracy.

(9) Before giving data collection sheets to data analysts for volume calculations, and while still at the test site, review data for errors.

### 5.2.3 Five-charge Row Cratering<sup>11</sup>

#### a. Predetonation Procedures

(1) Establish test site. Determine the charge weights, burial depths, and spacing required to produce a crater of the desired size.<sup>12</sup>

<sup>11</sup> Five-charge row craters are included as a specific example of multiple-charge row cratering, because the five-charge row configuration is standard for road craters. Refer to FM 5-25, paragraphs 3-16 and 3-17.

<sup>12</sup> See footnote 10 on page 14.

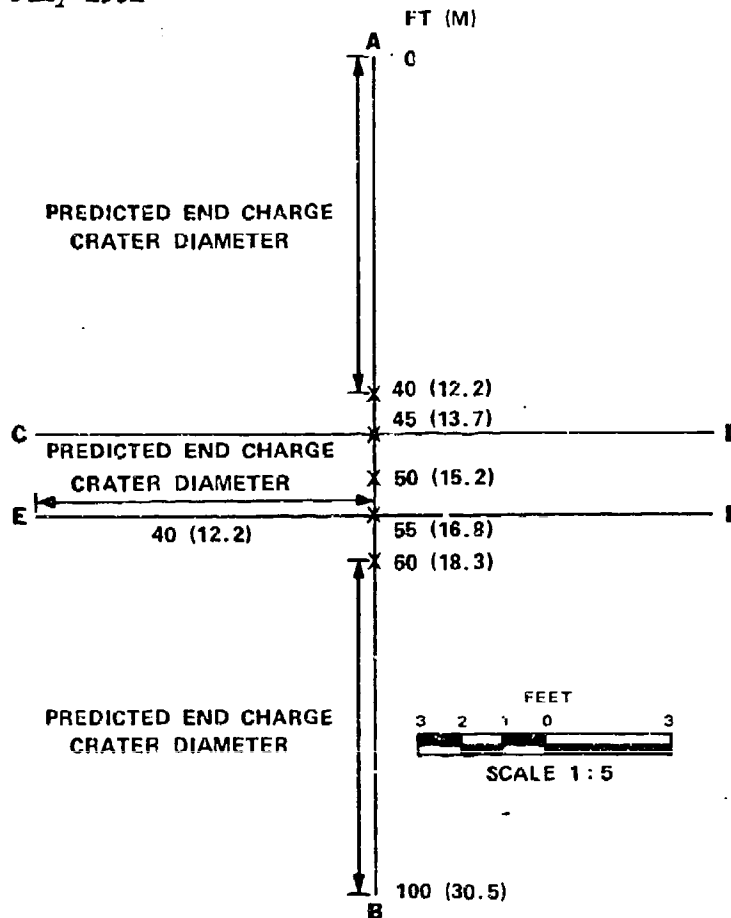

Figure 4. Cross-sectional Radii Locations for Five-charge Row Crater.

feet (12.2 m) each]. Cross-sectional radii are established over charge holes at the 45- and 55-foot (13.7 and 16.8 m) points on the longitudinal axis (approximately 20 percent of charge row length inward from each charge).

b. The remaining five-charge row crater procedures are identical to the multiple charge row crater procedures in paragraphs 5.2.2a(7) through 5.2.2c(9), above.

### 5.3 Data Required.

Complete data collection sheets (forms B-1, B-2, B-3, and B-5 for single-charge craters and forms B-1, B-2, B-4, and B-5 for multiple-charge row craters) for each crater.

(2) Prepare charge hole's in accordance with established crater design. Record each charge hole's diameter, depth, and method of preparation on form B-4.

(3) Establish longitudinal axis and cross-sectional radii, using procedures in paragraphs 5.2.2a(3) through (5), above, with one exception: Only two cross-sectional radii are required. Establish a radius over the charge holes nearest the points which are approximately 20 percent of charge row length inward from each end charge.

(4) For example, in figure 4, five charge holes are located 5 feet (1.5 m) apart, center to center, on a longitudinal axis 100 feet (30.5 m) long (20-foot (7 m) charge row length plus two predicted end charge crater diameters of 40

## 6. DATA REDUCTION AND PRESENTATION.

a. Encode direct measurement data obtained from data collection sheets (forms B-1 through B-5) on computer tape.

b. Use direct measurement data to calculate individual crater volumes. Appendix C provides three volume calculation methods:

(1) The theoretical procedure for predicting crater volumes (Appendix C, paragraph 1) is used to design craters and to calculate volumes for explosive performance predictions. This procedure was developed by USAWES.

(2) The empirical method for calculating crater volumes (Appendix C, paragraph 2) was also developed by USAWES. Empirically calculated volumes are compared with predicted volumes to assess the predictability of explosive performance.

(3) The procedure for approximating crater volumes in the field (Appendix C, paragraph 3) was developed at the US Army Tropic Test Center (USATTC), and is accurate to within 10 percent of the true crater volume.

c. Compare preand poststorage cratering performance among explosive types to assess deterioration caused by environmental storage.

d. Calibrate performance of all explosive types in each type of soil present in the test area. Use 2-foot (0.6 m) charge depth intervals between calibration extremes.

e. Determine mean and range of preparation times for each explosive type at the various sites.

f. Evaluate the effects of stemming and/or tamping on each explosive type.

g. Present direct measurement, site net slope, and direction of slope data in tabular format, as shown in tables 1 through 5.<sup>13</sup>

h. Assess cratering performance among explosive types by comparing excavated soil volumes for single charges. Present comparison data as shown in table 6.

i. Establish an index of single-charge explosive capability among explosive types similar to that shown in table 7.

---

<sup>13</sup> Data presented in tables 1 through 12 were developed during actual comparison tests of BA, AN, and TNT explosives in undisturbed, lateritic, silty clay soil (Frijoles clay). See footnote 1, page 2.

j. Compare multiple-charge row craters among explosive types by the average and range of row depth and radius distance. Summarize data as shown in table 8.

k. Compare actual and predicted crater volumes by explosive weight, type, and charge depth. Summarize data as shown in table 9, using the formula below to determine the cumulative percent accuracy. Figure 5 is a graphic presentation of table 9 data.

$$\text{Cumulative Percent Accuracy} = 100/n \sum_{i=1}^n \frac{O_i - M_i}{M_i}$$

NOTE:  $\bar{D}_s$  is slurry rows' average depth.

$$\bar{D} = \frac{1}{n} \sum_{k=1}^n \bar{D}_k$$

$\bar{R}_s$  is slurry rows' average radial distance.

$$\bar{R} = \frac{1}{n} \sum_{k=1}^n \bar{R}_k$$

l. Summarize meteorological conditions during each detonation as shown in table 10.

m. Analyze bulk soil samples and present soil characterization data for each crater site as shown in table 11.

n. Summarize pre- and post-detonation soil measurements as shown in table 12.

o. Identify test area soil types by means of a soil profile similar to figure 6.

p. Plot pre- and post-detonation elevation profile data for each site. Correlate crater plots with photographs of crater and ejecta. Figures 7 through 16 are samples of typical site plots and photographs.

q. Follow procedures discussed in Appendix C, paragraph 1a, to perform statistical regression analyses on test data.

r. Discuss unanticipated problems and recommended solutions.

s. Describe unusual experimental effects.

2 July 1981

TABLE 1. SUMMARY DATA FOR SINGLE-CHARGE CRATER, TNT, 40 POUNDS

Unit Distance from GZ(i) <sup>1</sup>	RADIAL MEASUREMENTS										CRATER FEATURES				MAX DEPTH
	Excavated Soil Depth (D) <sup>2</sup>					Slope					Lip Measurements				
											Width				
	N	S	E	W	AVG	N	S	E	W	AVG	N	S	E	W	
O	O	A	E		O	O	A	E		O	O	A	E		
R	U	S	S		R	U	S	S		R	U	S	S		
T	T	T	T		T	T	T	T		T	T	T	T		
H	H	T	T		H	H	T	T		H	H	T	T		
ft (m)	ft (m)					(tan θ) <sup>3</sup>					ft (m)				ft (m)
1 (0.30) (0.20)	4.75 (1.45)	4.75 (1.45)	5.08 (1.55)	5.08 (1.55)	4.92 (1.50)	1.81	0.47	0.59	2.45	8.10	5.70 (2.47)	6.20 (1.74)	6.20 (1.89)	6.60 (1.89)	0.67 (2.01)
2 (0.61)	4.25 (1.30)	4.42 (1.35)	5.67 (1.73)	4.25 (1.30)	4.65 (1.42)										
3 (0.91)	4.33 (1.32)	4.25 (1.30)	4.58 (1.40)	4.25 (1.30)	4.35 (1.33)										
4 (1.22)	4.17 (1.27)	3.67 (1.12)	3.75 (1.14)	4.42 (1.35)	4.00 (1.22)										
5 (1.52)	4.58 (1.40)	3.25 (0.99)	3.58 (1.09)	4.58 (1.40)	3.50 (1.07)										
6 (1.83)	2.25 (0.69)	2.67 (0.81)	3.08 (0.94)	3.42 (1.04)	2.86 (0.87)										
7 (2.13)	—	1.58 (0.48)	2.25 (0.69)	0.92 (0.28)	1.19 (0.36)										
8 (2.44)	—	1.25 (0.38)	1.58 (0.48)	0.67 (0.20)	0.88 (0.27)										
9 (2.74)	—	1.00 (0.30)	1.17 (0.36)	0.42 (0.13)	0.65 (0.20)										
10 (3.05)	—	0.25 (0.08)	—	—	0.06 (0.02)										
11 (3.35)	—	0.08 (0.02)	—	—	0.02 (0.01)										
Radial Length	5.90 (1.80)	10.30 (3.14)	8.80 (2.68)	8.80 (2.68)	8.45 <sup>4</sup> (2.58)										

LOCATION: All craters were located within Area I.

SITE: Site 3. Coordinates PA29522009 to 29602035  
to 29682023 to 29602017.

<sup>1</sup> Foot unit = i-1.

<sup>2</sup> At measurement radial intersection points, the north/south depth will usually differ from the east/west depth because the (i-1) person will trample/tramp the fallback during each crater transit, thus causing the subsequent depth measurement to be greater than the initial depth measurement.

<sup>3</sup> θ is the angle between the horizontal and that radial's predominant crater wall.

<sup>4</sup> Radius of theoretical circular crater.

2 July 1981

TOP 4-2-830

**TABLE 2. SUMMARY DATA FOR SINGLE-CHARGE CRATER, STANDARD ARMY CRATERING CHARGE, 40 POUNDS**

Unit Distance From CZ (i) <sup>1</sup>	RADIAL MEASUREMENTS										CRATER FEATURES				AVG	MAX DEPTH
	Excavated Soil Depth (D) <sup>1</sup>					Slope					Lip Measurements					
											Width					
	N	S	E	W	AVG	N	S	E	W	AVG	N	S	E	W		
O	O	A	E		O	O	A	E		O	O	A	E			
R	U	A	E		R	U	A	E		R	U	A	E			
T	T	S	S		T	T	S	S		T	T	S	S			
H	H	T	T		H	H	T	T		H	H	T	T			
ft (m)	ft (m)				(tan θ) <sup>2</sup>					ft (m)				ft (m)		
1 (0.30)	4.67 (1.42)	4.67 (1.42)	4.25 (1.30)	4.25 (1.30)	4.46 (1.36)	3.98	0.59	0.76	0.57	7.10 (2.16)	5.50 (1.68)	3.10 (0.94)	3.20 (0.98)	4.70 (1.43)	1.00 (0.30)	
2 (0.61)	4.67 (1.42)	4.00 (1.22)	4.25 (1.30)	3.67 (1.12)	4.15 (1.26)											
3 (0.91)	4.67 (1.42)	3.50 (1.07)	4.25 (1.30)	3.33 (1.01)	3.94 (1.20)											
4 (1.22)	4.08 (1.24)	3.00 (0.91)	4.33 (1.32)	2.67 (0.81)	3.52 (1.07)											
5 (1.52)	3.75 (1.14)	1.50 (0.46)	2.75 (0.84)	2.00 (0.61)	2.50 (0.76)											
6 (1.83)	3.50 (1.07)	2.33 (0.71)	3.75 (1.14)	1.92 (0.59)	2.88 (0.88)											
7 (2.13)	2.42 (0.74)	1.58 (0.48)	2.92 (0.89)	0.83 (0.25)	1.94 (0.59)											
8 (2.44)	2.42 (0.74)	0.33 (0.10)	2.67 (0.81)	0.25 (0.08)	1.42 (0.43)											
9 (2.74)	—	—	1.58 (0.48)	—	0.40 (0.12)											
10 (3.05)	—	—	0.75 (0.23)	—	0.19 (0.06)											
11 (3.35)	—	—	0.17 (0.05)	—	0.04 (0.01)											
Radial Length	7.90 (2.41)	7.50 (2.29)	10.90 (3.32)	7.80 (2.38)	8.53 <sup>3</sup> (2.60) <sup>4</sup>											

LOCATION: All craters were located within Area I.

SITE: Site 3. Coordinates PA29522009 to 29602035 to 29682023 to 29602017.

<sup>1</sup> Foot unit = 1-1.

<sup>2</sup> At measurement radial intersection points, the north/south depth will usually differ from the east/west depth because the rod person will trample/tramp the fallback during each crater transit, thus causing the subsequent depth measurement to be greater than the initial depth measurement.

<sup>3</sup> θ is the angle between the horizontal and that radial's predominant crater wall.

<sup>4</sup> Radius of theoretical circular crater.

TABLE 3. SUMMARY DATA FOR SINGLE-CHARGE CRATER, SLURRY, 40 POUNDS

Unit Distance from CZ(i) <sup>1</sup>	RADIAL MEASUREMENTS					CRATER FEATURES					MAX DEPTH				
	Excavated Soil Depth (D) <sup>2</sup>					Slope				Lip Measurements					
						(tan θ) <sup>3</sup>				Width					
	N	S	E	W	AVG	N	S	E	W	N		S	E	W	AVG
O	O	A	E		O	O	A	E	O	O	A	E			
R	U	A	E		R	U	A	E	R	U	A	E			
T	T	S	S		T	T	S	S	T	T	S	S			
H	H	T	T		H	H	T	T	H	H	T	T			
ft (m)	ft (m)				(tan θ) <sup>3</sup>				ft (m)				ft (m)		
1 (0.30)	6.33 (1.93)	6.33 (1.93)	6.08 (1.85)	6.08 (1.85)	6.21 (1.89)	0.59	0.52	0.52	0.57	8.00 (2.44)	10.00 (3.05)	9.90 (3.02)	8.10 (2.47)	9.00 (2.74)	1.00 (0.30)
2 (0.61)	5.83 (1.78)	5.92 (1.80)	5.92 (1.80)	4.83 (1.47)	5.63 (1.72)										
3 (0.91)	5.42 (1.65)	5.75 (1.75)	6.17 (1.88)	4.83 (1.47)	5.54 (1.69)										
4 (1.22)	5.17 (1.58)	5.58 (1.70)	5.83 (1.70)	3.83 (1.17)	5.10 (1.55)										
5 (1.52)	4.42 (1.35)	4.75 (1.45)	5.25 (1.60)	3.83 (1.17)	4.56 (1.39)										
6 (1.83)	4.17 (1.27)	4.33 (1.32)	3.83 (1.17)	3.83 (1.17)	4.04 (1.23)										
7 (2.13)	4.17 (1.27)	4.83 (1.47)	3.58 (1.09)	2.83 (0.86)	3.85 (1.17)										
8 (2.44)	3.00 (0.91)	2.25 (0.69)	2.92 (0.89)	1.75 (0.53)	2.48 (0.76)										
9 (2.74)	2.33 (0.71)	2.17 (0.66)	2.58 (0.79)	1.75 (0.53)	2.21 (0.67)										
10 (3.05)	1.33 (0.41)	2.25 (0.69)	2.00 (0.61)	1.92 (0.59)	1.88 (0.57)										
11 (3.35)	0.17 (0.05)	0.00 (0.00)	2.08 (0.63)	— (—)	0.06 (0.02)										
12 (3.66)	0.08 (0.02)	— (—)	— (—)	— (—)	0.02 (0.01)										
13 (3.96)	0.00 (0.00)	— (—)	— (—)	— (—)	0.00 (0.00)										
Radial Length	12.00 (3.66)	10.00 (3.05)	10.10 (3.08)	9.90 (3.02)	11.20* (3.41)*										

LOCATION: All craters were located within Area I.

SITE: Site 3. Coordinates PA29522009 to 29602035 to 29682023 to 29602017.

<sup>1</sup> Foot unit = i-1.

<sup>2</sup> At measurement radial intersection points, the north/south depth will usually differ from the east/west depth because the rod person will trample/tramp the fallback during each crater transit, thus causing the subsequent depth measurement to be greater than the initial depth measurement.

<sup>3</sup> θ is the angle between the horizontal and that radial's predominant crater wall.

\* Radius of theoretical circular crater.

TABLE 4. SUMMARY DATA FOR FIVE-CHARGE CRATER, SLURRY, 320 POUNDS

Unit Distance from GZ(i) <sup>1</sup>	Depth (D) <sup>2</sup> of the Radial Measurements						
	$\overline{BA}^3$	$\overline{CD}^3$	$\overline{FB}^3$	$\overline{BG}^3$	$\overline{CH}^3$	$\overline{CJ}^3$	$\overline{BC}^3$
ft (m)	ft (m)	ft (m)	ft (m)	ft (m)	ft (m)	ft (m)	ft (m)
1	9.64	8.20	9.49	9.49	8.38	8.38	9.64
(0.30)	(2.94)	(2.50)	(2.89)	(2.89)	(2.55)	(2.55)	(2.94)
2	9.50	7.80	9.31	9.47	8.45	8.28	9.78
(0.61)	(2.90)	(2.38)	(2.84)	(2.89)	(2.58)	(2.52)	(2.98)
3	9.30	7.39	8.84	8.97	7.92	8.23	9.72
(0.91)	(2.83)	(2.25)	(2.69)	(2.73)	(2.41)	(2.51)	(2.96)
4	9.11	7.00	8.36	8.48	7.40	7.84	9.67
(1.22)	(2.78)	(2.13)	(2.55)	(2.58)	(2.26)	(2.39)	(2.95)
5	8.92	6.62	7.89	7.99	6.86	7.44	9.59
(1.52)	(2.72)	(2.02)	(2.40)	(2.44)	(2.09)	(2.27)	(2.92)
6	8.72	6.23	7.42	7.49	6.34	6.97	9.53
(1.83)	(2.66)	(1.90)	(2.26)	(2.28)	(1.93)	(2.12)	(2.90)
7	8.14	5.82	6.97	7.00	5.87	6.50	9.27
(2.13)	(2.48)	(1.77)	(2.12)	(2.13)	(1.79)	(1.98)	(2.83)
8	7.59	5.42	6.50	6.55	5.40	6.04	9.01
(2.44)	(2.31)	(1.65)	(1.98)	(2.00)	(1.65)	(1.84)	(2.75)
9	7.03	5.01	5.99	6.02	4.95	5.42	8.74
(2.74)	(2.14)	(1.53)	(1.83)	(1.83)	(1.51)	(1.65)	(2.66)
10	6.48	4.44	5.48	5.53	4.50	4.79	8.48
(3.05)	(1.98)	(1.35)	(1.67)	(1.69)	(1.37)	(1.46)	(2.58)
11	5.93	3.88	4.70	5.06	4.03	4.17	8.20
(3.35)	(1.81)	(1.18)	(1.43)	(1.54)	(1.23)	(1.27)	(2.50)
12	5.38	3.30	3.93	4.05	3.41	3.54	—
(3.66)	(1.64)	(1.01)	(1.20)	(1.23)	(1.04)	(1.08)	—
13	4.79	2.74	3.33	3.09	2.80	2.27	—
(3.97)	(1.46)	(0.84)	(1.01)	(0.94)	(0.85)	(0.69)	—
35	-0.37	-0.42	-1.05	-0.91	-0.83	-0.95	—
(10.67)	(-0.11)	(-0.13)	(-0.32)	(-0.28)	(-0.25)	(-0.29)	—
36	-0.35	-0.36	-0.99	-0.81	-0.66	-0.90	—
(10.97)	(-0.11)	(-0.11)	(-0.30)	(-0.25)	(-0.20)	(-0.27)	—
37	—	—	-0.92	-0.72	-0.64	-0.86	—
(11.28)	—	—	(-0.28)	(-0.22)	(-0.20)	(-0.26)	—
38	—	—	-0.84	-0.62	-0.64	-0.81	—
(11.58)	—	—	(-0.26)	(-0.19)	(-0.20)	(-0.25)	—
39	—	—	-0.77	-0.58	-0.62	-0.75	—
(11.89)	—	—	(-0.23)	(-0.18)	(-0.19)	(-0.23)	—
40	—	—	-0.78	-0.56	-0.60	-0.69	—
(12.19)	—	—	(-0.24)	(-0.17)	(-0.18)	(-0.21)	—
41	—	—	-0.79	-0.52	-0.58	-0.63	—
(12.44)	—	—	(-0.24)	(-0.16)	(-0.18)	(-0.19)	—

<sup>1</sup> Foot unit = 1-1.<sup>2</sup> At measurement radial intersection points, the north/south depth will usually differ from the east/west depth because the rod person will trample/tramp the fallback during each crater transit, thus causing the subsequent depth measurement to be greater than the initial depth measurement.<sup>3</sup>  $\overline{BA}$  is the line segment from point B to point A, etc.

RADIAL ID

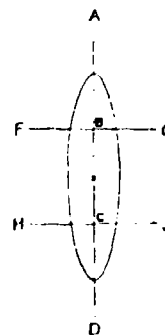

TABLE 5. SUMMARY DATA FOR 12-CHARGE CRATER, SLURRY, 760 POUNDS

Unit Distance From GZ(i)1	Depth (D) <sup>2</sup> of the Radial Measurements									
	BA3	CD3	DE3	EG3	BF3	CH3	CJ3	DK3	DL3	EC3
	ft (m)	ft (m)	ft (m)	ft (m)	ft (m)	ft (m)	ft (m)	ft (m)	ft (m)	ft (m)
1	9.89	10.12	9.52	9.16	9.16	10.20	10.20	9.73	9.73	9.89
(0.30)	(3.01)	(3.08)	(2.90)	(2.79)	(2.79)	(3.11)	(3.11)	(2.97)	(2.97)	(3.01)
2	9.82	10.02	8.23	9.05	9.18	10.01	10.03	9.06	9.34	9.95
(0.61)	(2.99)	(3.05)	(2.51)	(2.76)	(2.80)	(3.05)	(3.06)	(2.76)	(2.85)	(3.03)
3	9.75	8.47	9.56	8.72	9.18	9.83	9.87	8.39	8.93	10.01
(0.91)	(2.97)	(2.58)	(2.91)	(2.66)	(2.80)	(3.00)	(3.01)	(2.56)	(2.72)	(3.05)
4	9.67	8.65	9.48	8.34	8.54	9.63	9.74	7.73	8.55	10.07
(1.22)	(2.95)	(2.64)	(2.89)	(2.54)	(2.60)	(2.94)	(2.97)	(2.36)	(2.61)	(3.07)
5	9.59	8.83	9.40	7.96	7.91	9.45	9.01	7.37	8.18	10.10
(1.52)	(2.92)	(2.69)	(2.87)	(2.43)	(2.41)	(2.88)	(2.75)	(2.25)	(2.49)	(3.08)
6	9.51	9.01	9.31	7.58	7.33	8.45	8.27	7.00	7.54	10.13
(1.83)	(2.90)	(2.75)	(2.84)	(2.31)	(2.23)	(2.58)	(2.52)	(2.13)	(2.30)	(3.09)
7	9.24	9.10	9.28	7.21	6.19	7.46	7.52	6.63	6.89	10.19
(2.13)	(2.82)	(2.77)	(2.83)	(2.20)	(1.89)	(2.27)	(2.29)	(2.02)	(2.10)	(3.11)
8	8.96	9.19	9.25	6.84	5.93	6.53	6.78	6.26	6.25	10.24
(2.44)	(2.73)	(2.80)	(2.82)	(2.08)	(1.81)	(1.99)	(2.07)	(1.91)	(1.91)	(3.12)
9	8.69	10.23	9.14	6.48	5.65	5.63	6.02	4.66	5.60	10.25
(2.74)	(2.65)	(3.12)	(2.79)	(1.98)	(1.72)	(1.72)	(1.83)	(1.42)	(1.71)	(3.12)
10	8.42	10.18	8.90	5.70	3.09	4.71	5.25	4.29	4.56	10.27
(3.05)	(2.57)	(3.10)	(2.71)	(1.74)	(0.94)	(1.44)	(1.60)	(1.31)	(1.51)	(3.13)
11	17.27	10.06	8.66	4.93	2.08	3.81	4.49	32.91	4.33	10.28
(3.35)	(2.22)	(3.07)	(2.64)	(1.50)	(0.63)	(1.16)	(1.37)	(3.19)	(1.32)	(3.13)
12	7.26	9.94	8.46	4.15	0.57	3.01	3.91	3.47	3.71	10.22
(3.66)	(2.21)	(3.03)	(2.58)	(1.26)	(0.17)	(0.92)	(1.19)	(1.06)	(1.13)	(3.12)
13	7.22	9.83	8.24	3.41	0.70	2.73	3.33	3.05	3.09	10.15
(3.96)	(2.20)	(3.00)	(2.51)	(1.04)	(0.21)	(0.83)	(1.01)	(0.93)	(0.94)	(3.09)
14	7.19	9.73	8.01	1.95	0.10	2.44	2.75	2.62	2.40	10.15
(4.27)	(2.19)	(2.97)	(2.44)	(0.59)	(0.03)	(0.74)	(0.84)	(0.80)	(0.76)	(3.09)
15	6.74	9.63	7.46	0.51	-0.48	2.14	2.17	2.24	1.86	10.15
(4.57)	(2.05)	(2.94)	(2.27)	(0.16)	(-0.15)	(0.65)	(0.66)	(0.68)	(0.57)	(3.09)
16	6.44	9.52	6.92	0.47	-1.06	1.85	1.63	0.73	1.23	10.12
(4.88)	(1.96)	(2.90)	(2.11)	(0.14)	(-0.32)	(0.56)	(0.50)	(0.22)	(0.37)	(3.08)
17	6.11	—	6.38	0.45	-1.64	1.54	1.10	0.49	-0.81	—
(5.18)	(1.86)	—	(1.94)	(0.14)	(-0.50)	(0.47)	(0.34)	(0.15)	(-0.25)	—
18	5.79	—	5.81	0.41	-4.50	1.24	-0.89	0.26	-1.11	—
(5.48)	(1.76)	—	(1.77)	(0.12)	(-1.37)	(0.38)	(-0.27)	(0.08)	(-0.34)	—
40	0.01	—	-1.19	-0.59	-0.98	-1.01	-0.63	-1.51	-0.51	—
(12.19)	(0.00)	—	(-0.36)	(-0.18)	(-0.30)	(-0.31)	(-0.19)	(-0.46)	(-0.16)	—
41	0.00	—	-0.24	-0.59	-1.07	-0.88	-0.59	-1.69	-0.44	—
(12.49)	(0.00)	—	(-0.07)	(-0.18)	(-0.33)	(-0.27)	(-0.18)	(-0.52)	(-0.13)	—
42	0.00	—	-0.20	—	—	—	—	—	—	—
(12.80)	(0.00)	—	(-0.06)	—	—	—	—	—	—	—
43	-0.10	—	-0.15	—	—	—	—	—	—	—
(13.10)	(-0.03)	—	(-0.05)	—	—	—	—	—	—	—
44	—	—	-0.11	—	—	—	—	—	—	—
(13.41)	—	—	(-0.03)	—	—	—	—	—	—	—

<sup>1</sup> Foot unit = i-l.

<sup>2</sup> At measurement radial intersection points, the north/south depth will usually differ from the east/west depth because the rod person will trample/tramp the fallback during each crater transit, thus causing the subsequent depth measurement to be greater than the initial depth measurement.

<sup>3</sup> BA is the line segment from point B to point A, etc.

RADIAL ID

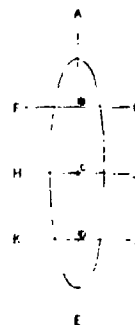

TABLE 6. PERFORMANCE COMPARISON—SINGLE-CHARGE CRATERS

Crater ID	Max Depth		Average Radius		Volume		Remarks
	ft	(m)	ft	(m)	ft <sup>3</sup>	(m <sup>3</sup> )	
T	5.6	(1.71)	8.5	(2.59)	523.0	(14.8)	Fireball 1
A	5.1	(1.55)	9.2	(2.80)	512.4	(14.5)	Fireball 1
S	6.8	(2.07)	11.7	(3.56)	1021.3	(28.9)	Fireball 1

## FIREBALL LEGEND:

0	None	Subjective Light Intensity
1	Slight	
2	Medium	
3	High	

TABLE 7. EXPLOSIVE CAPABILITY INDEX—SINGLE-CHARGE CRATERS

Crater ID	Type Explosive	Performance Ratio			
		TNT/AN	AN/TNT	ES/TNT	ES/AN
T	TNT	1.05			
A	AN		1.05		
S	ES			2.10	2.05

NOTES: Experimental crater volume averages were used for performance ratio computations. Averages are as follows:

$$\begin{aligned} T: & 485.9 \text{ ft}^3 \text{ (13.76 m}^3\text{)} \\ A: & 498.1 \text{ ft}^3 \text{ (14.10 m}^3\text{)} \end{aligned}$$

Performance ratios (TNT/AN, AN/TNT, ES/TNT, ES/AN) are the ratios of the specific test site volume (table 6) to the average volume for the other types of explosive (table 6), taken one type at a time.

$$\begin{aligned} \frac{V_{T(\text{EXP})}}{V_{A(\text{AVG})}} &= \frac{523.0}{498.1} = 1.05 \\ \frac{V_{S(\text{EXP})}}{V_{T(\text{AVG})}} &= \frac{1021.3}{485.9} = 2.10 \end{aligned}$$

TABLE 8. COMPARISON DATA—MULTIPLE-CHARGE ROW CRATER

Row Crater ID	Radial	Max Depth		Max Radial Distance		Average Crater Max Depth		Averages Radius (E & W)	
		(D)	(m)	(R)	(m)	( $\bar{D}$ )	(m)	( $\bar{R}$ )	(m)
T	E2	6.77	(2.06)	13.5	(4.11)	7.52	(2.29)	14.00	(4.27)
	W2	6.77	(2.06)	12.5	(3.81)				
	E4	8.00	(2.44)	14.5	(4.42)				
	W4	8.00	(2.44)	15.5	(4.72)				
	N	7.78	(2.37)	21.5	(6.55)				
	S	7.78	(2.37)	21.5	(6.55)				
A	E2	7.11	(2.17)	12.5	(3.81)	7.35	(2.24)	12.43	(3.79)
	W2	7.11	(2.17)	12.5	(3.81)				
	E4	7.20	(2.19)	12.8	(3.90)				
	N4	7.20	(2.19)	11.9	(3.63)				
	N	7.74	(2.36)	21.5	(6.55)				
	S	7.74	(2.36)	19.1	(5.82)				
S	E2	9.49	(2.89)	15.5	(4.72)	9.13	(2.78)	15.33	(4.67)
	W2	9.49	(2.89)	16.5	(5.03)				
	E4	8.38	(2.55)	13.5	(4.11)				
	W4	8.38	(2.55)	15.8	(4.82)				
	N	9.53	(2.90)	21.5	(6.55)				
	S	9.53	(2.90)	22.9	(6.98)				

## GRAND MEANS:

	$\bar{D}$	(m)	$\bar{R}$	(m)
T row craters	7.03	(2.14)	12.95	(3.95)
A row craters	6.93	(2.11)	12.16	(3.71)
S row craters	8.20	(2.50)	15.43	(4.70)

TABLE 9. COMPARISON DATA FOR PREDICTED AND MEASURED  
VOLUMES—EXPLOSIVE SLURRY

Site Number	Crater Volume		
	Predicted (P) (m <sup>3</sup> )	Measured (M) (m <sup>3</sup> )	Individual Crater Accuracy ((P-M)/M)100 (%)
B1	19.1	25.9	-26.3
B3	19.1	21.8	-12.4
B5	19.1	28.9	-33.9
B7	19.1	29.9	-36.1
B9	19.1	18.3	+ 4.4
B11	19.1	22.6	-15.5
S1	19.1	23.7	-19.4
S2	19.1	22.9	-16.6
Average	19.1	24.3	-21.4

TABLE 10. METEOROLOGICAL DATA—TYPICAL SINGLE-CHARGE CRATERING

Crater ID	Ambient Temperature		Relative Humidity (%)	Wind Speed (knots)	Wind Direction (°True)	Rainfall	
	°F	(°C)				in	(mm)
TNT	85.1	(29.5)	84	2.5	285	0.00	(0.00)
AN	83.5	(28.6)	78	3.0	398	0.00	(0.00)
ES	91.1	(32.8)	62	3.0	285	0.00	(0.00)

TABLE 11. SOIL CHARACTERIZATION DATA

Depth of Sample ft (m)	USCS (type)	Moisture Content (%)	Atterberg Limits		
			LL	PL	PI
2 (0.61)	Silty Clay (MH)	47.4	59	46	13
4 (1.23)	Silty Clay (MH)	48.9	78	57	21
6 (1.84)	Silty Clay (MH)	48.4	57	45	12

**LEGEND:**

LL—Liquid Limit; PL—Plastic Limit; PI—Plastic Index;  
USCS—Unified Soil Classification System.

TABLE 12. PRE- AND POSTDETONATION SOIL DATA--SINGLE-CHARGE CRATER

Blast Direction	Crater No.	Cone Index, Depth (in)						Cone Index for Average Layer, Depth (in)			Moisture Content (%)	
		3	6	9	12	18	24	0-6	6-12	12-18		18-24
		psi (kg/cm <sup>2</sup> )						psi (kg/cm <sup>2</sup> )				
BEFORE	T2	40	102	116	152	242	262	78	123	197	252	
		(2.3)	(7.2)	(8.2)	(10.7)	(17.0)	(18.4)	(5.5)	(8.6)	(13.8)	(17.7)	
	T2	40	106	158	186	266	284	91	157	226	275	
		(2.8)	(7.5)	(11.1)	(13.1)	(18.7)	(20.0)	(6.4)	(11.0)	(15.9)	(19.3)	
AFTER	T2	17	33	44	58	66	102	31	56	78	96	55.00
		(1.2)	(2.3)	(3.1)	(4.1)	(4.6)	(7.2)	(2.2)	(3.9)	(5.5)	(6.7)	
	T2	18	54	86	84	87	118	53	86	103	123	
		(1.3)	(3.8)	(6.0)	(5.9)	(6.1)	(8.3)	(3.7)	(6.0)	(7.2)	(8.6)	

NOTE: This table is a representative sample extracted from data for a TNT crater. Tabled values (cone penetrometer readings) are twice the psi value.

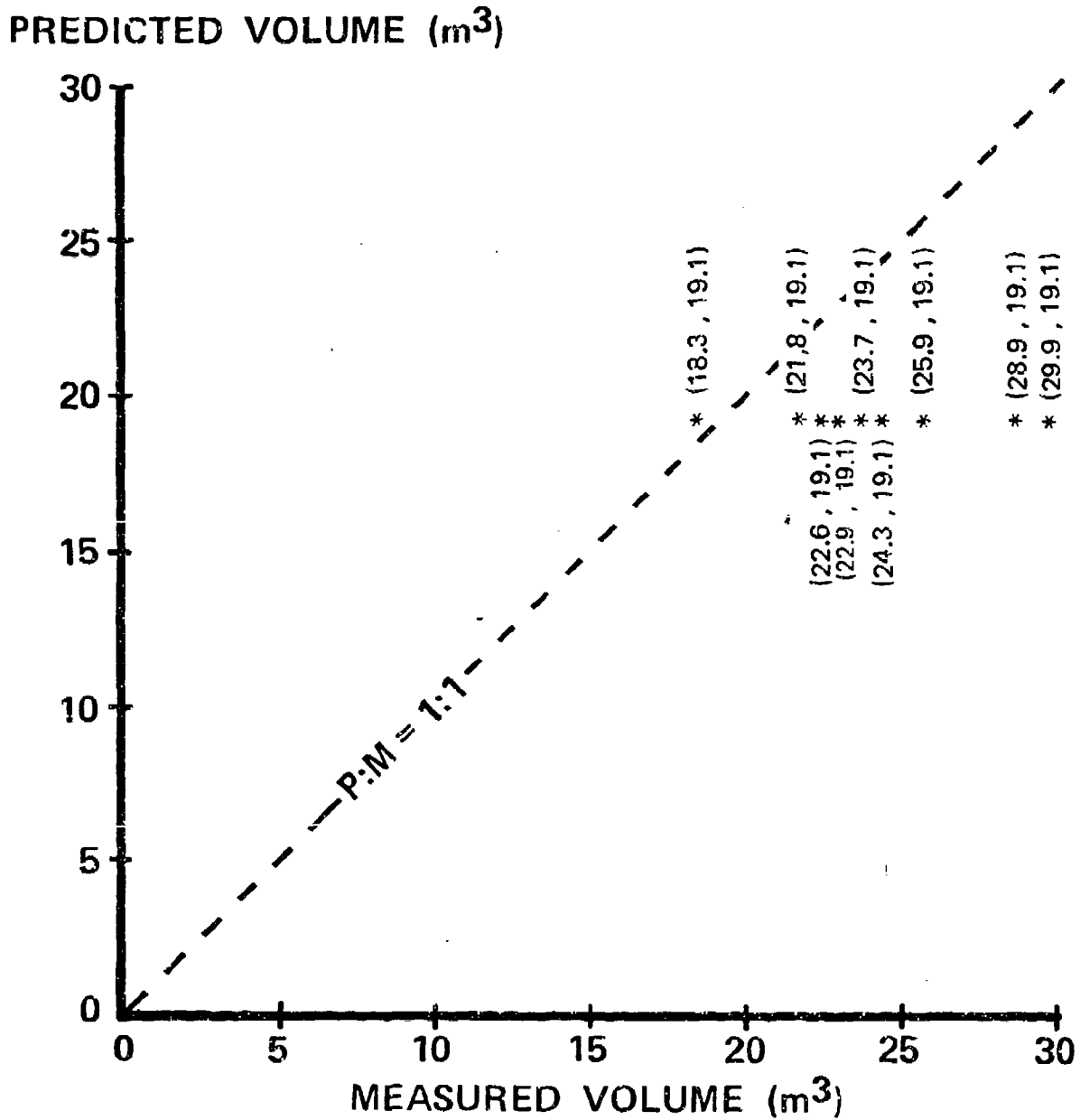

Figure 5. Comparison of Measured and Predicted Cratering Performance for Explosive Slurry (summarization of data in table 9, above).

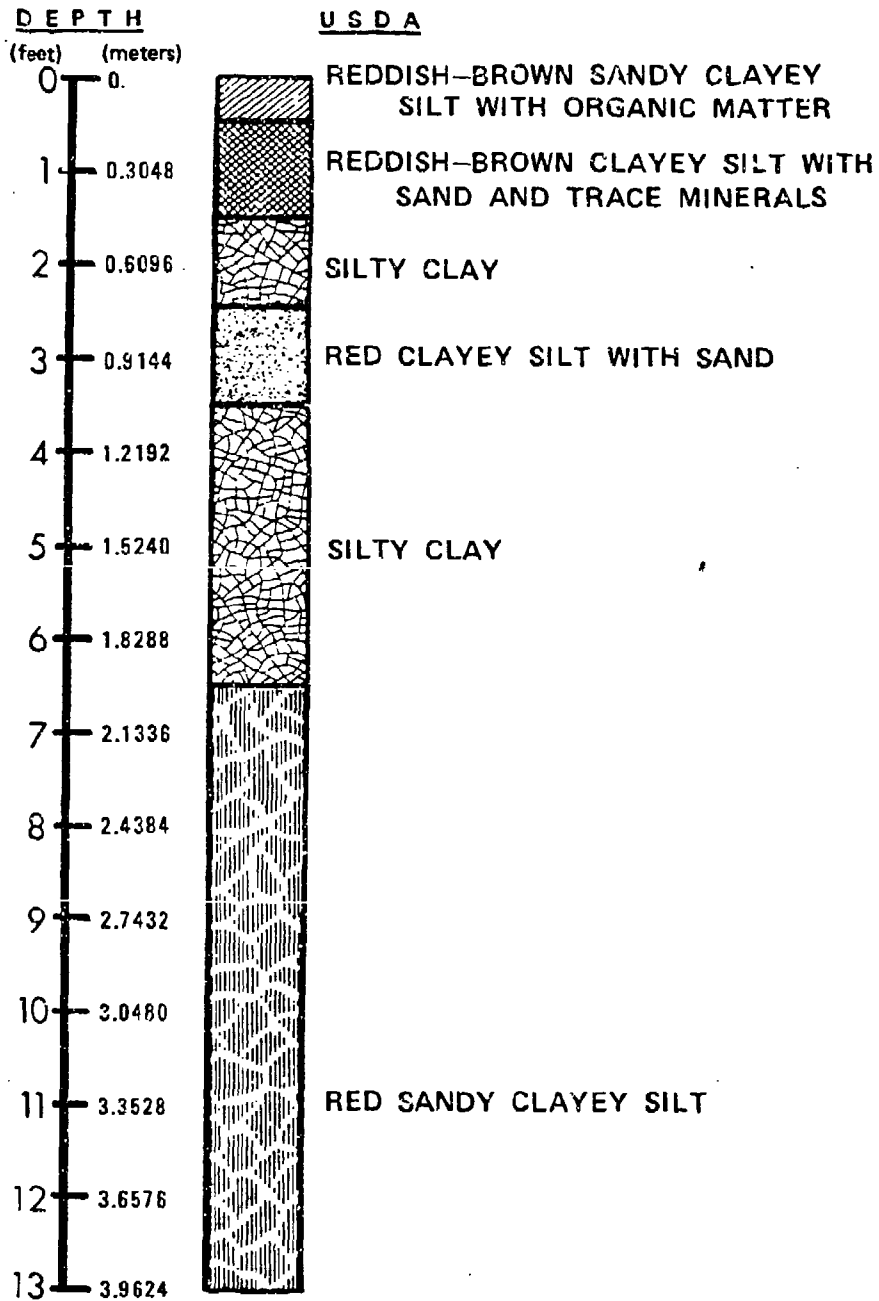

Figure 6. Typical Test Area Soil Profile.

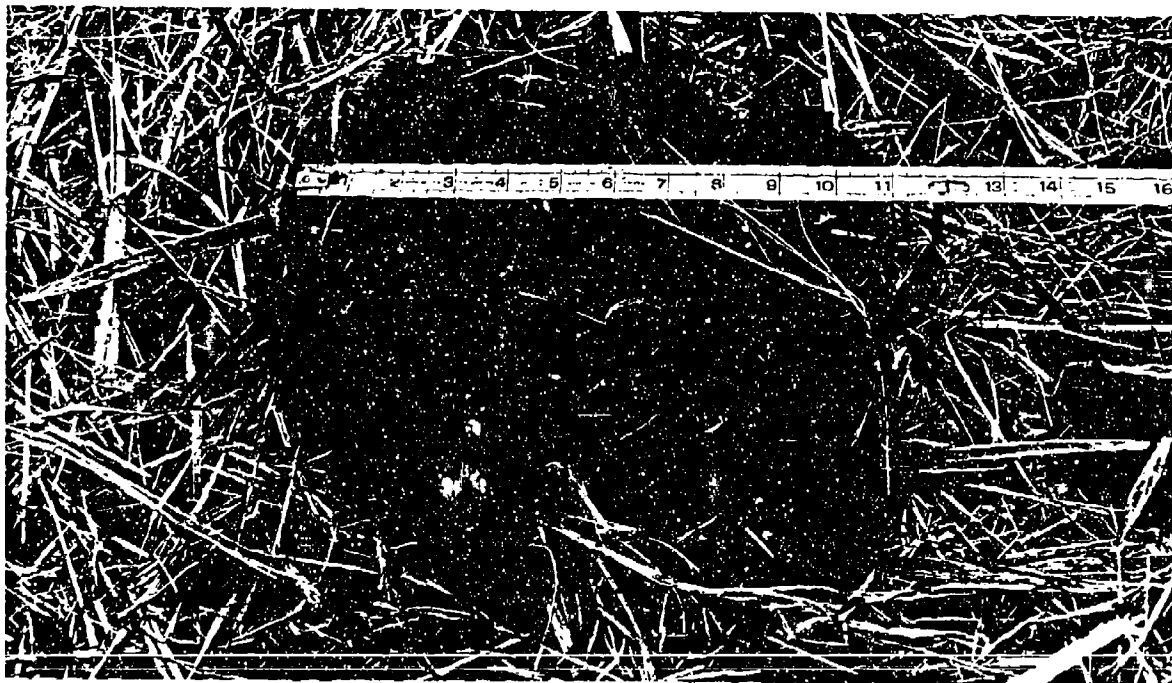

Figure 7. Crater T Maximum Size Ejecta, 120 Feet (36.58 m) from Ground Zero.

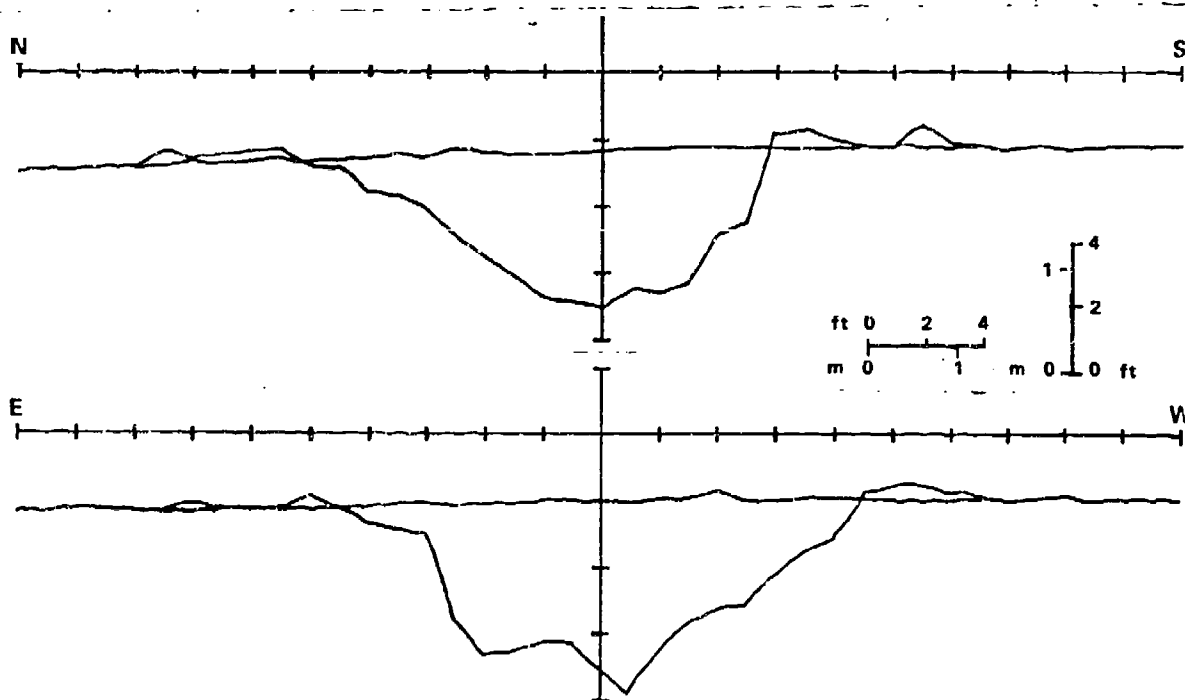

Figure 8. TNT Crater—Cross-Sectional Profile.



Figure 9. Ground View of Crater T Looking North.



Figure 10. Ground View of Crater A Looking Northwest.

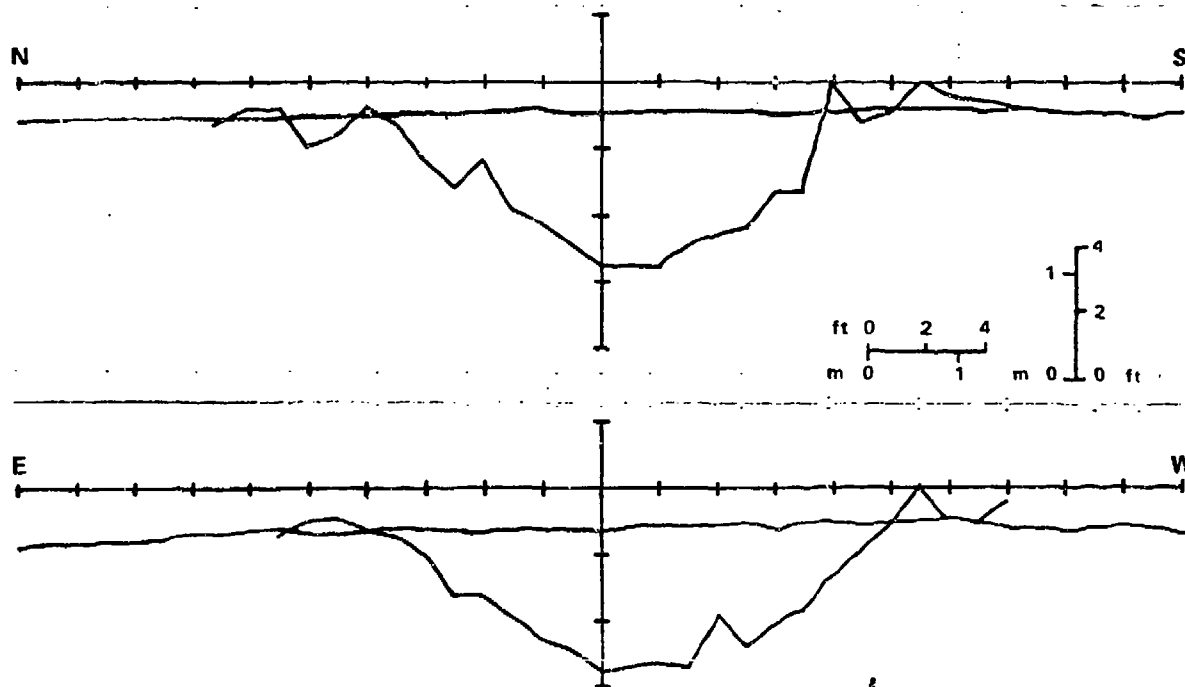

Figure 11. Ammonium Nitrate Crater—Cross-Sectional Profile.

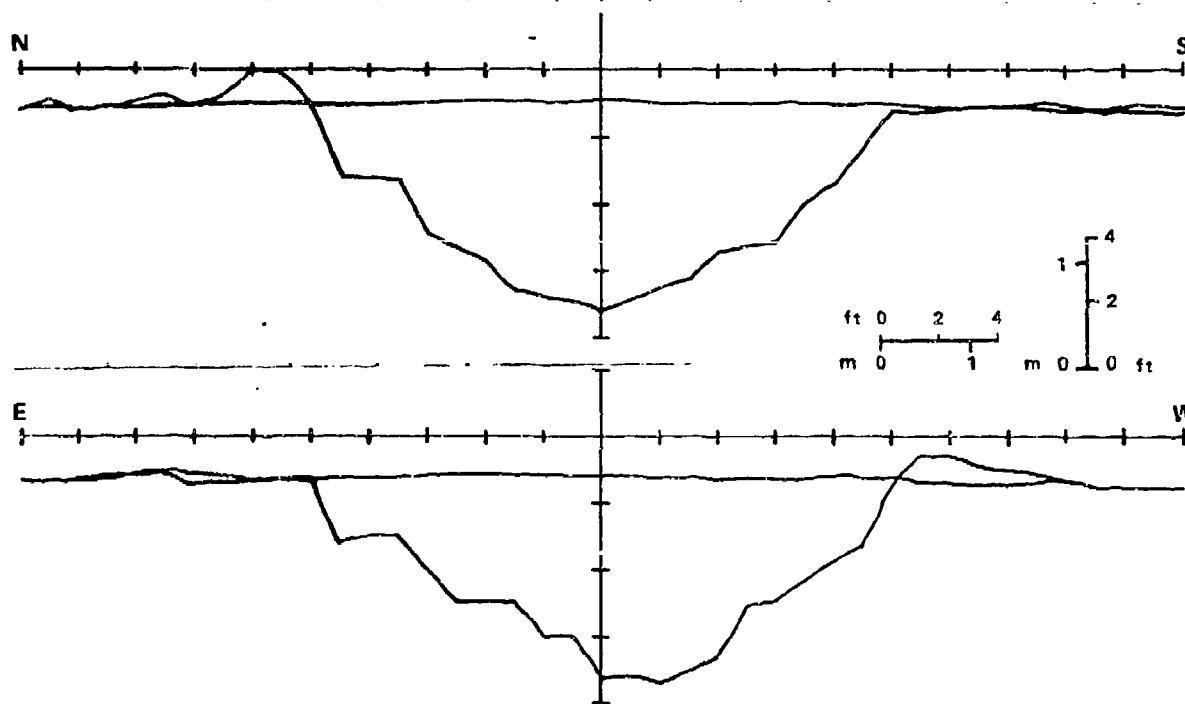

Figure 12. Slurry Crater—Cross-Sectional Profile.



Figure 13. Ground View of Slurry Crater Looking Southeast.

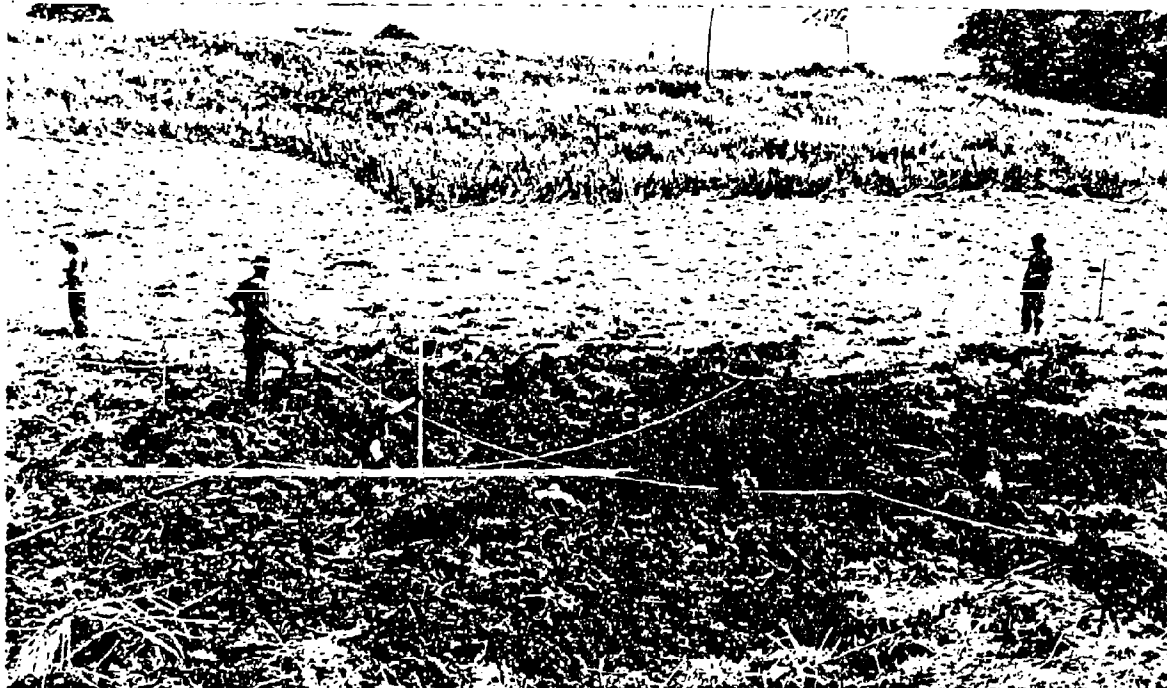

Figure 14. Ground View of Slurry Crater Looking Southwest.



Figure 15. Slurry Crater Ejecta with Unexploded Slurry.

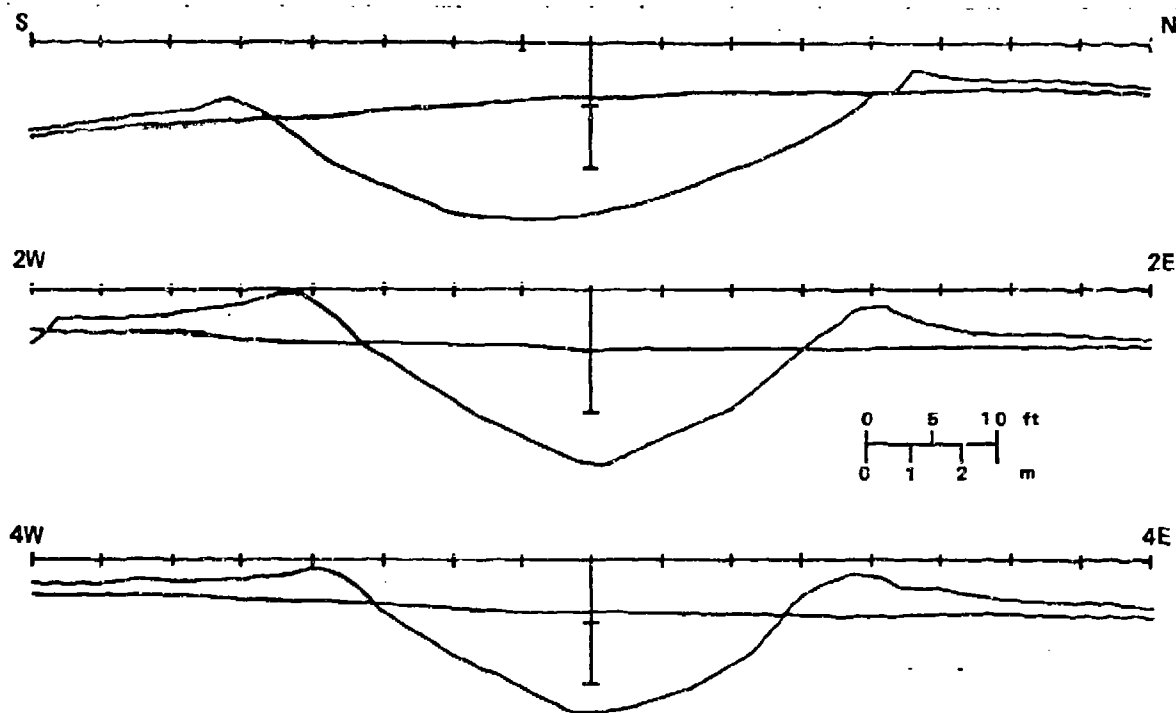

Figure 16. Slurry Row Crater—Cross-Sectional Profile.



Figure 17. Ground View of Slurry Row Crater Looking North.

Recommended changes to this publication should be forwarded to Commander, US Army Test and Evaluation Command, ATTN: DRSTE-AD-M, Aberdeen Proving Ground, MD 21005. Technical information may be obtained from the preparing activity: Commander, US Army Tropic Test Center, ATTN: STETC-MID, APO Miami 34004. Additional copies are available from the Defense Technical Information Center, Cameron Station, Alexandria, VA 22314. This document is identified by the accession number (AD No.) printed on the first page.

APPENDIX A. CHECKLISTS

This appendix contains sample checklists for use in conducting field tests of chemical explosives and munitions. They should be used as guides only. Adapt checklists to specific test requirements by deleting and adding tasks as appropriate.

A-1. Task Checklist for Single-charge Crater Tests

Test Title \_\_\_\_\_

TECOM Project No. \_\_\_\_\_ Date \_\_\_\_\_

Complete each task in the order indicated and check the "DONE" column. Check "NA" if a task doesn't apply to a specific crater site.

TASK	DONE	NA	COMMENTS
<u>Predetonation Procedures</u> (paragraph 5.2.1a)			
1. Establish crater site and prepare charge hole at site ground zero.			
2. Record charge hole preparation data on form B-3.			
3. Establish four radii, one at each cardinal point.			
4. Determine predicted radius length.			
5. Place a stake on all four radii, sufficiently distant from the predicted crater radius to preclude disturbance by detonation.			
6. Record radius stake distance and direction from ground zero on form B-3.			

## A-1. Task Checklist for Single-charge Crater Tests (cont)

TASK	DONE	NA	COMMENTS
<u>Predetonation Procedures (cont)</u>			
7. Attach steel measuring tapes in a straight line between the north and south radius stakes and between the east and west stakes.			
8. Place measuring instrument in position to see all four radii.			
9. Place reference stake under surveying instrument.			
10. Record instrument height on form B-1.			
11. Establish bench mark and record its elevation on form B-1.			
12. Measure the vertical distance from instrument line-of-sight to the ground along the entire length of the north to south and east to west lines (3-foot (0.9 m) intervals for flat ground, 1-foot (0.3 m) intervals for irregular terrain).			
13. Record rod readings on form B-1.			
14. Plot unusual terrain features at actual location and record readings on form B-1.			

## A-1. Task Checklist for Single-charge Crater Tests (cont)

TASK	DONE	NA	COMMENTS
<u>Predetonation Procedures (cont)</u>			
15. Record radius stake elevations, strike of slope, and slope compass azimuth on form B-3.			
16. Collect soil strength and moisture data at selected points along the north to south and east to west lines, and record them on form B-5.			
17. Remove measuring tapes and surveying instrument.			
18. Collect bulk soil samples and submit to laboratory for analysis.			
<u>Charge Emplacement and Detonation (paragraph 5.2.lb)</u>			
1. Place prepared explosive in charge hole.			
2. Record data on form B-3 for charge type and weight, charge placement, booster and primer type and location, detonation cord type and position, charge hole condition, and firing system used.			
3. If field-mixed explosive is used, record preparation and gel times on form B-3.			

## A-1. Task Checklist for Single-charge Crater Tests (cont)

TASK	DONE	NA	COMMENTS
<u>Charge Emplacement and Detonation</u> <u>(cont)</u>			
4. Clear crater site and insure that personnel have moved to designated safe area.			
5. Detonate charge.			
6. Record time of detonation on Form B-3.			
7. Record subjective evaluation of fireball intensity on form B-3.			
8. Record relative humidity, wind speed and direction, and temperature during detonation on form B-3.			
<u>Postdetonation Procedures</u> <u>(paragraph 5.2.1c)</u>			
1. Reposition measuring instrument and measuring tapes.			
2. Obtain instrument height from bench mark and record it on form B-1.			
3. Identify original ground level at edge of ejecta.			
4. Obtain rod readings to edge of ejecta, original ground level, or radius stake, whichever is located first. Record rod readings on form B-1.			

## A-1. Task Checklist for Single-charge Crater Tests (concluded)

TASK	DONE	NA	COMMENTS
<u>Postdetonation Procedures (cont)</u>			
5. Locate apparent crater wall.			
6. Record distance between ground zero and apparent crater wall on form B-3.			
7. Record ejecta descriptions and measurements on form B-3.			
8. Obtain postdetonation soil measurements and record them on form B-5.			
9. Perform field volume calculations.			
10. Review data collection sheets for errors.			

A-2. Task Checklist for Multiple-charge Row Crater Tests

Test Title \_\_\_\_\_

TECOM Project No. \_\_\_\_\_ Date \_\_\_\_\_

Complete each task in the order indicated and check the "DONE" column. Check "NA" if a task doesn't apply to a specific crater site.

TASK	DONE	NA	COMMENTS
<u>Predetonation Procedures</u> (paragraph 5.2.2a)			
1. Establish crater site.			
2. Establish longitudinal axis equal to length of charge row plus two predicted end charge crater diameters.			
3. Prepare charge holes and record preparation data on form B-4.			
4. Establish required number of cross-sectional radii (two for seven or fewer charges, three for eight or more charges).			
5. Place stakes at ends of each radius, and at each end of longitudinal axis.			
6. Attach steel measuring tapes to longitudinal axis stakes.			
7. Attach tapes to radius stakes, forming lines which bisect longitudinal axis at right angles.			

2 July 1981

TOP 4-2-830

A-2. Task Checklist for Multiple-charge Row Crater Tests (cont)

TASK	DONE	NA	COMMENTS
<u>Predetonation Procedures (cont)</u>			
8. Position measuring instrument so that all radius/axis stakes can be seen.			
9. Record instrument height on form B-1.			
10. Place reference stake under measuring instrument.			
11. Record longitudinal axis azimuth and length, elevation of radius and axis stakes, strike of slope, and slope compass azimuth on form B-4.			
12. Determine distance and direction from longitudinal axis for each radius stake. Record data on form B-4.			
13. Measure vertical distance from instrument line-of-sight to the ground, along entire length of longitudinal axis and all radii (3-foot (0.9 m) intervals for flat ground, 1-foot (0.3 m) intervals for irregular terrain).			
14. Record rod readings on form B-1.			

## A-2. Task Checklist for Multiple-charge Row Crater Tests (cont)

TASK	DCNF	NA	COMMENTS
<u>Predetonation Procedures (cont)</u>			
15. Plot unusual terrain features at actual location and record rod readings on form B-1.			
16. Collect soil strength and moisture data at selected points along each radius and the longitudinal axis, and record them on form B-5.			
17. Remove measuring tapes and surveying instrument.			
18. Collect bulk soil samples and submit to laboratory for analysis.			
<u>Charge Emplacement and Detonation (paragraph 5.2.2b)</u>			
1. Place prepared explosives in charge holes.			
2. Record data on form B-4 for charge type and weights, booster and primer types and locations, detonation cord type and positions, charge hole conditions, and firing system used.			
3. If field-mixed explosives are used, record preparation and gel times on form B-4.			

## A-2. Task Checklist for Multiple-charge Row Crater Tests (cont)

TASK	DONE	NA	COMMENTS
<u>Charge Emplacement and Detonation</u> (cont)			
4. Clear crater site and insure that personnel have moved to designated safe area.			
5. Detonate charges.			
6. Record time of detonation on form B-4.			
7. Record subjective evaluation of fireball intensity on form B-4.			
8. Record relative humidity, wind speed and direction, and temperature during detonation on form B-4.			
<u>Postdetonation Procedures</u> (paragraph 5.2.2c)			
1. Reposition measuring instrument and measuring tapes.			
2. Obtain instrument height from bench mark and record it on form B-1.			
3. Identify original ground level at edge of ejecta.			
4. Obtain rod readings to edge of ejecta, original ground level, or radius stake, whichever is reached first. Record rod readings on form B-1.			



APPENDIX B. DATA COLLECTION SHEETS

(Form B-1 begins on the following page.)

FORM B-1. ELEVATION PROFILE DATA COLLECTION SHEET

Site No. \_\_\_\_\_  Predetonation  Postdetonation  
 Instrument Height \_\_\_\_\_ ft (m) Bench Mark Elevation \_\_\_\_\_ ft (m)

Data Recorded by: \_\_\_\_\_ Data Checked by: \_\_\_\_\_

NOTE: Record data at integer increments.

STA	RR	EL	STA	RR	EL	STA	RR	EL	STA	RR	EL
0			40		80	120		160			
1			41		81	121		161			
2			42		82	122		162			
3			43		83	123		163			
4			44		84	124		164			
5			45		85	125		165			
6			46		86	126		166			
7			47		87	127		167			
8			48		88	128		168			
9			49		89	129		169			
10			50		90	130		170			
11			51		91	131		171			
12			52		92	132		172			
13			53		93	133		173			
14			54		94	134		174			
15			55		95	135		175			
16			56		96	136		176			
17			57		97	137		177			
18			58		98	138		178			

2 July 1981

TOP 4-2-830

19	59	99	139	179
20	60	100	140	180
21	61	101	141	181
22	62	102	142	182
23	63	103	143	183
24	64	104	144	184
25	65	105	145	185
26	66	106	146	186
27	67	107	147	187
28	68	108	148	188
29	69	109	149	189
30	70	110	150	190
31	71	111	151	191
32	72	112	152	192
33	73	113	153	193
34	74	114	154	194
35	75	115	155	195
36	76	116	156	196
37	77	117	157	197
38	78	118	158	198
39	79	119	159	199
				200

NOTE: STA = Station Number; RR = Rod Reading; EL = Elevation.

FORM B-2. FIELD VOLUME CALCULATIONSNOTE: One data set of  $i = 1$  to 50 for each crater radius measured.

$i +$ Unit Distance from GZ	Pre- detonation Elevation	Post- detonation Elevation	Excavated Depth	Correction Factor	Excavated Depth	Average Slice Depth	Slice Volume
(i)	(P <sub>i</sub> )	(Q <sub>i</sub> )	(D <sub>i</sub> )	(±F)	(D <sub>i+1</sub> )	$\frac{(D_i + D_{i+1})}{2}$	$\frac{\pi}{2}(1 + 2i)(D_i + D_{i+1})$
1							
2							
3							
4							
5							
6							
7							
8							
9							
10							
11							
12							
13							
14							
15							
16							
17							
18							
19							
20							
21							
22							
23							
24							
25							
26							
27							
28							
29							
30							
31							
32							
33							
34							
35							
36							
37							
38							
39							
40							
41							

Subtotal: \_\_\_\_\_

2 July 1981

TOP 4-2-830

FORM B-2. FIELD VOLUME CALCULATIONS (concluded)

1 + Unit Distance from GZ	Pre- detonation Elevation	Post- detonation Elevation	Excavated Depth	Correction Factor	Excavated Depth	Average Slice Depth	Slice Volume
(i)	(P <sub>i</sub> )	(Q <sub>i</sub> )	(D <sub>i</sub> )	(±F)	(D <sub>i+1</sub> )	$\frac{(D_i + D_{i+1})}{2}$	$\frac{\pi}{2}(1 + 2i)(D_i + D_{i+1})$
42							
43							
44							
45							
46							
47							
48							
49							
50							

Subtotal<sub>2</sub> \_\_\_\_\_

Subtotal<sub>1</sub> \_\_\_\_\_

Grand Total (crater volume) \_\_\_\_\_

NOTES: 1.  $\pm$  may be negative or positive.  
 2. Explosive charge weight and equipment availability determine the horizontal increment between depth measurements. There is an inverse relationship between horizontal measurement interval and calculation accuracy. Analyze data on the basis of integer distances between depth measurements. When non-integer distances are used as measurement intervals, obtain crater volume (ft<sup>3</sup>/m<sup>3</sup>) by using the appropriate conversion factor after integer unit volume is obtained.

3. Excavated Soil Depth (D<sub>i</sub>):

i = 1 + Distance from ground zero (feet and inches or meters)

BM = Bench mark

P<sub>i</sub> = Predetonation elevation

Q<sub>i</sub> = Postdetonation elevation

F = Correction factor from bench mark instrument heights = P<sub>BM</sub> - Q<sub>BM</sub>

D<sub>i</sub> = P<sub>i</sub> - Q<sub>i</sub> + F

n = number of positive depth increments.

$$\text{TOTAL VOLUME} = \frac{\pi}{2} \sum_{i=1}^{n-1} (1 + 2i) (D_i + D_{i+1})$$

If crater wall is not an even foot/meter increment, compute the volume of that segment:

r = crater wall distance from ground zero.

$$V = \frac{\pi}{2} (r^2 - n^2) (D_n - D_{n-1})$$



2 July 1981

TOP 4-2-830

FORM B-3. SINGLE-CHARGE CRATER DATA COLLECTION SHEET (cont)

Charge Hole Condition  Unstemmed  Stemmed Stemming Material \_\_\_\_\_

Fireball Intensity:

None  Slight  Medium  High

Charge Preparation Time \_\_\_\_\_ min Gel Time \_\_\_\_\_ hr/min  
(for field-mixed explosives)

Crater Wall Dimensions:

Distance from ground zero \_\_\_\_\_ ft \_\_\_\_\_ inches (m)

Elevation \_\_\_\_\_ ft \_\_\_\_\_ inches (m)

Ejecta at Given Distances:

Distance from ground zero 100 ft (30.5 m) 200 ft (61 m) Other \_\_\_\_\_

Geometric shape \_\_\_\_\_

Dimensions \_\_\_\_\_

Description \_\_\_\_\_

Largest Discrete Ejecta (clods):

Distance from ground zero \_\_\_\_\_ ft (m)

Geometric shape \_\_\_\_\_

Dimensions \_\_\_\_\_

Description \_\_\_\_\_

Typical Ejecta:

Distance from ground zero \_\_\_\_\_ ft (m)

Geometric shape \_\_\_\_\_

Dimensions \_\_\_\_\_

Description \_\_\_\_\_

Meteorological Data:

Relative Humidity \_\_\_\_\_ % Wind Speed \_\_\_\_\_ mph (kph)

Wind Direction \_\_\_\_\_ °T Temperature \_\_\_\_\_ °F (°C)

NOTE: Complete one form for each radius.

## FORM B-4. MULTIPLE-CHARGE ROW CRATER DATA COLLECTION SHEET

Crater No. \_\_\_\_\_ Date \_\_\_\_\_

Grid Coordinates \_\_\_\_\_ Test Officer/NOO \_\_\_\_\_

Data Recorded by \_\_\_\_\_ Data Checked by \_\_\_\_\_

Time at Detonation \_\_\_\_\_

## Preliminary Soil Classification:

Grassland     Dry     White     Homogeneous     Soil  
 Shrubs/Bushes     Moist     Yellow     Mixed     Sand  
 Young Forest     Wet     Red     Solid     Rock  
 Mature Forest     Saturated     Brown     Streaked     Clay  
 Black     Homogeneous  
 Mixed

## Charge Hole Data:

 Method of Preparation \_\_\_\_\_ Spacing \_\_\_\_\_ ft (m)  
 (auger, shaped charge, other)

	Charge Hole A	Charge Hole B	Charge Hole C	Charge Hole D	Charge Hole E
Depth					
Diameter					

## Survey Points:

Longitudinal Axis: Distance between axis stakes \_\_\_\_\_ ft (m)

Longitudinal axis azimuth \_\_\_\_\_ deg

2 July 1981

TOP 4-2-830

FORM B-4. MULTIPLE-CHARGE ROW CRATER DATA COLLECTION SHEET (cont)

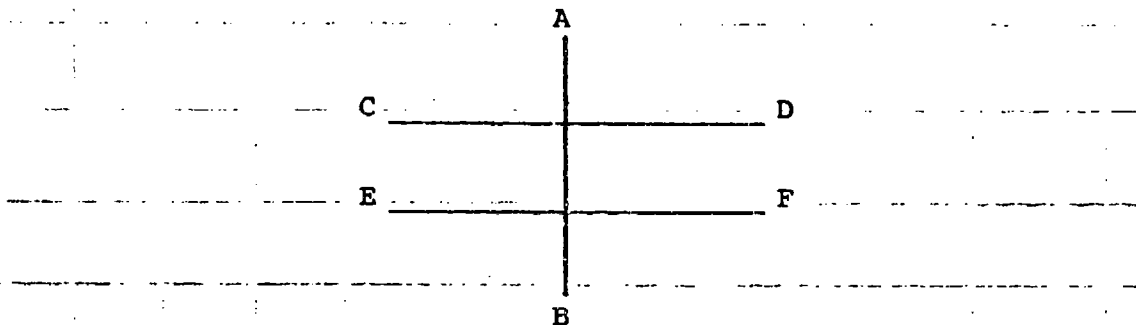

NOTE: Measured distance is from radius stake C, D, E, F, to  $\overline{AB}$  (circle the appropriate radius stake).

Radius Stake

Location: Distance from longitudinal axis \_\_\_\_\_ ft (m)

Direction from longitudinal axis (north, west, etc.) \_\_\_\_\_ deg

Elevation \_\_\_\_\_ ft (m)

Charge Emplacement and Detonation Data:

Charge Hole	Explosive Type	Charge Weight	Placement (describe)
A			
B			
C			
D			
E			

Distance from charge hole top to top of charge (ft (m)):

Charge Hole: A \_\_\_\_\_ B \_\_\_\_\_ C \_\_\_\_\_ D \_\_\_\_\_ E \_\_\_\_\_

Booster/primer Type \_\_\_\_\_ Location \_\_\_\_\_

Detonation Cord Type \_\_\_\_\_ Position \_\_\_\_\_

FORM B-4. MULTIPLE-CHARGE ROW CRATER DATA COLLECTION SHEET (cont)

Charge Hole Condition:

Charge Hole	Unstemmed	Stemmed	Stemming Material
A			
B			
C			
D			
E			

Fireball Intensity:

None     Slight     Medium     High

Charge Preparation Time \_\_\_\_\_ min Gel Time \_\_\_\_\_ hr/min  
 (for field-mixed explosives)

Crater Wall Dimensions:

Distance from longitudinal axis \_\_\_\_\_ ft \_\_\_\_\_ inches (m)  
 Elevation \_\_\_\_\_ ft \_\_\_\_\_ inches (m)

Ejecta at Given Distances:

	100 ft (30.5 m)	200 ft (61 m)	Other
Geometric shape	_____	_____	_____
Dimensions	_____	_____	_____
Description	_____	_____	_____

Largest Discrete Ejecta (clods):

Distance from longitudinal axis \_\_\_\_\_ ft (m)  
 Geometric shape \_\_\_\_\_  
 Dimensions \_\_\_\_\_  
 Description \_\_\_\_\_

2 July 1981

TOP 4-2-830

FORM B-4. MULTIPLE-CHARGE ROW CRATER DATA COLLECTION SHEET (concluded)

Typical Ejecta:

Distance from longitudinal axis \_\_\_\_\_ ft (m)

Geometric shape \_\_\_\_\_

Dimensions \_\_\_\_\_

Description \_\_\_\_\_

Meteorological Data:

Relative Humidity \_\_\_\_\_ % Wind Speed \_\_\_\_\_ mph (kph)

Wind Direction \_\_\_\_\_ deg Temperature \_\_\_\_\_ °F (°C)

NOTES: 1. Complete one form for each radius (C, D, E, and F) and for the longitudinal axis.

2. Explosive charge weight and equipment availability determine the horizontal increment between depth measurements. Note the inverse relationship between horizontal measurement interval and measurement accuracy.



APPENDIX C. CALCULATIONS

## 1. THEORETICAL PREDICTIONS

a. Crater Design Procedures

Information in this paragraph was extracted from the USAWES report, Explosive Ditching with TNT.<sup>1</sup> Figures C-1 and C-2, below, illustrate TNT cratering predictions for sandstone. To make predictions for TNT cratering in other media and applications, refer to the USAWES report.

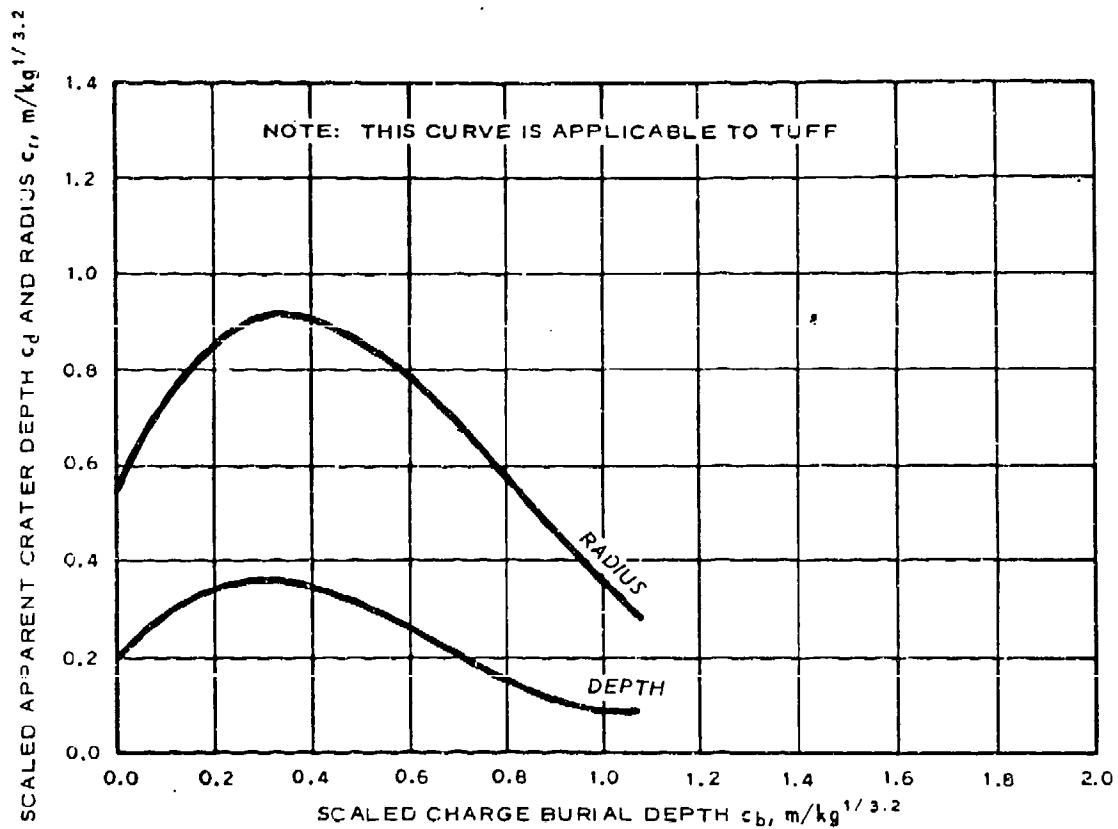
EQUATIONS

OPTIMUM BURIAL DEPTH	$B = 0.32w^{1/3.2}$
APPARENT RADIUS	$R = 0.91w^{1/3.2}$
APPARENT DEPTH	$D = 0.36w^{1/3.2}$
APPARENT VOLUME	$V = 0.34w^{3/3.2}$

Figure C-1. Scaled Dimension Curve for Sandstone (figure 7a of USAWES report).

<sup>1</sup> Miscellaneous Paper N-77-7, Explosive Ditching with TNT, USAWES, July 1977.

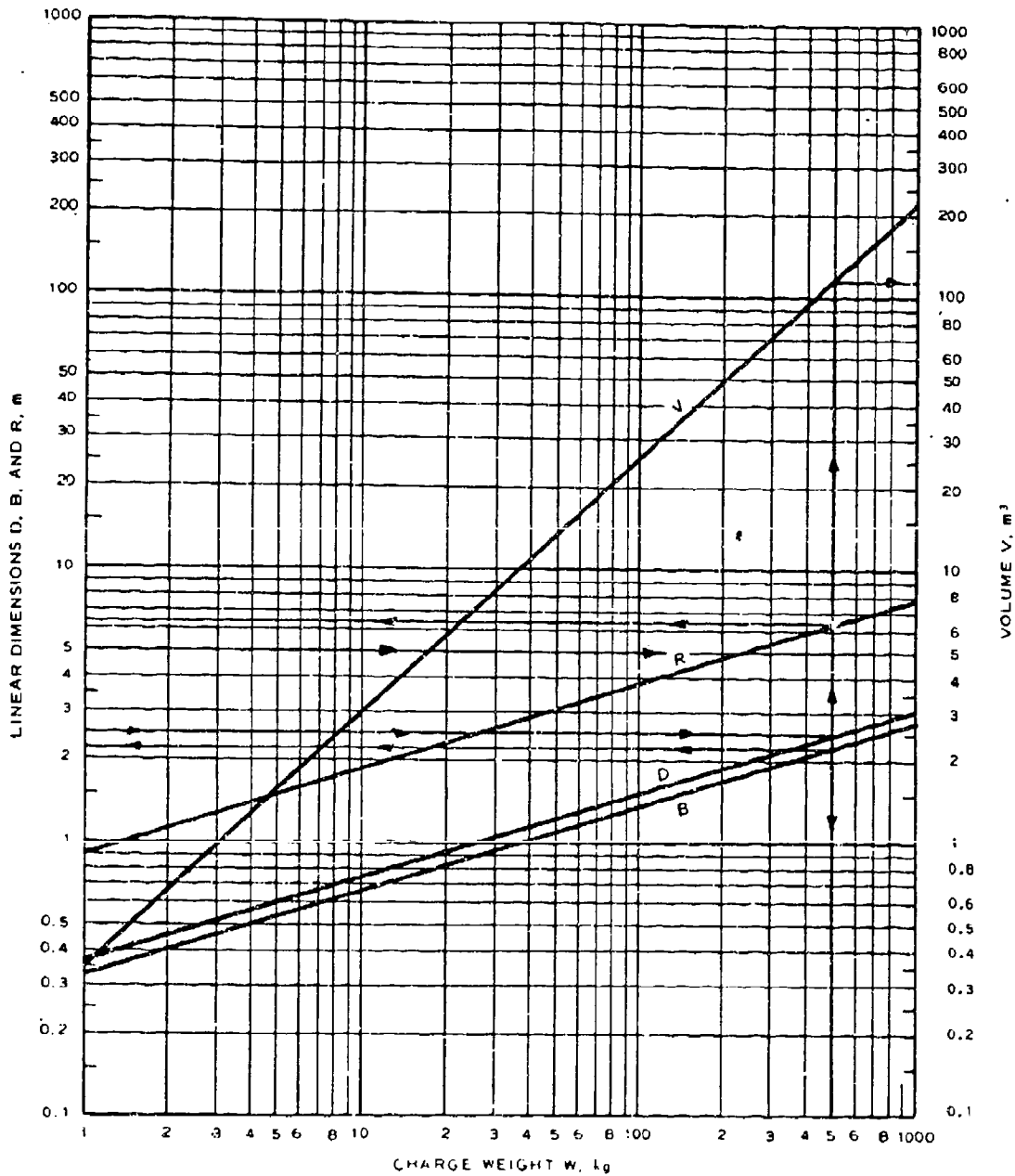

Figure C-2. Design Chart for Sandstone (figure 7 of USAWES report).

2 July 1981

TOP 4-2-830

(1) Appendixes A and B of the USAWES report list all high-explosive single crater data available from references listed therein. A statistical regression analysis was performed on available TNT data to produce data plots for nine media. Two plots were produced for each medium: (a) a scaled dimension plot (figure C-1), and (b) a design chart (figure C-2). Each design chart graphically relates charge weights on the abscissa to crater dimensions and volumes on the ordinate. In analyzing TNT data and preparing data plots, USAWES personnel used the following criteria:

(a) The metric (SI) system of units was used; i.e., linear dimensions are expressed in meters, volumes in cubic meters, and charge weights in kilograms.

(b) Data from different sites were grouped together if they represented similar media. Refer to the USAWES report for classification parameters.

(c) The third-order polynomial fit was chosen to represent the scaled dimension curves.

(d) The least-squares method was used to fit the curves.

(e) The value of  $a$  was assumed to be 3.0, 3.1, 3.2 . . . 3.6 for each medium, and the value that presented the smallest scatter between data point plots for all charge weights was chosen as the representative value for the considered medium.

(f) In preparing the design charts, the optimum burial depth for each medium was considered to be the average of the optimum burial depths for crater radius and depth as determined from the peaks of the curves on the corresponding scaled dimension plot.

(g) Scaled radius and scaled depth curves are presented in the same chart.

(h) Only the parameter obtained from the scaled volume curve is presented, not the curve.

(2) Example. To determine the single-charge weight of TNT and charge burial depth necessary to excavate a crater with an apparent radius of at least 5 meters and an apparent depth of at least 2.5 meters in sandstone, use the following procedures:

(a) Enter figure C-2 at  $R = 5.0$  and read 233 kilograms on curve R. Enter figure C-2 at  $D = 2.5$  and read  $\pm 495$  kilograms on curve D. The value  $\pm 495$  from curve D is larger than the value 233 from curve R; therefore, a charge weight of 495 kilograms must be used.

2 July 1981

(b) Read values of R, B, and V from the appropriate curves for a charge of 495 kilograms:

$$R = 6.3 \text{ m}$$

$$B = 2.2 \text{ m}$$

$$V = 113 \text{ m}^3$$

#### b. Crater Volume Predictions

(1) In the USAWES report coefficient  $a = 3$  is stipulated for cratering with TNT in either wet clay or saturated silty clay. For the purposes of this illustration, an area of saturated silty clay is specified; so, the coefficient of  $a = 3$  will be used.

(2) Example of a crater volume prediction is as follows: Given a 41-pound (18.6 kg) charge of TNT, what will the crater parameters be for B, R, D, and V?

(a) In the USAWES report, figure 12 shows the following TNT metric cratering relationships:

$$B = 0.57w^{1/3}$$

$$R = 1.03w^{1/3}$$

$$D = 0.51w^{1/3}$$

$$V = 0.72w$$

(b) Therefore,

$$B = 4.95 \text{ feet (1.51 m)}$$

$$R = 8.96 \text{ feet (2.73 m)}$$

$$D = 4.43 \text{ feet (1.35 m)}$$

$$V = 472.9 \text{ cubic feet (13.39 m}^3\text{)}$$

(3) In explosives applications, when the center of charge depth is other than optimum, a smaller crater will occur—a camuflot and a puff of smoke will result from the extreme case of excessively deep charge placement. For the following example, the customer directed the bottom of the charge to be at 5 feet (1.52 m). This put the center of the charge (B) at approximately 4.75 feet (1.45 m) rather than at 4.95 feet (1.51 m). The result was the creation of a crater that was smaller than maximum size.

2 July 1981

TOP 4-2-830

(a) From graphic analysis, TNT crater parameter predictions were developed:<sup>2</sup>

$$R = 8.56 \text{ feet (2.61 m)}$$

$$D = 4.25 \text{ feet (1.29 m)}$$

$$V = 455.0 \text{ cubic feet (12.88 m}^3\text{)}$$

(b) We know that  $V_{AN} = 1.1V_{TNT}$  and  $V_{BA} = 1.5V_{TNT}$ , so

$$V_{AN} = 500.5 \text{ cubic feet (14.17 m}^3\text{)}$$

$$V_{BA} = 682.5 \text{ cubic feet (19.32 m}^3\text{)}$$

c. Using the above procedures the following crater volume predictions were obtained:

TYPE EXPLOSIVE	CHARGE		VOLUME	
	lb	(kg)	ft <sup>3</sup>	(m <sup>3</sup> )
TNT	40	(18.14)	485.9	(13.76)
AN	40	(18.14)	508.9	(14.41)
BA	40	(18.14)	697.9	(19.76)

d. While paragraphs (2)(a) through (3)(c), above, provide methods for calculating TNT crater volumes and converting them to associated AN and BA crater volumes, prediction of cratering performance for explosives other than TNT forms a relatively small set of data. Therefore, cratering technology indicates the need for additional research integrating charge size, type, and placement prior to detonation to predict other cratering explosive applications.

## 2. EMPIRICAL VOLUME CALCULATIONS

a. Crater volumes were calculated using the following procedures:<sup>3</sup> Crater depth measurements were taken at discrete points along each of the crater's four cardinal radii; i.e., radii running north, south, east and west. For each set of depth measurements associated with a cardinal radius, an approximate crater volume was calculated using equation 3, below. These calculated volumes were then averaged to determine the final best estimate for

<sup>2</sup> Example based on TNT, AN, and BA comparison tests conducted at US Army Tropic Test Center. Refer to Final Report of Development Test II (Prototype Qualification Test--Government) of Demolition Kit, Blasting: XM268, TECOM Project No. 8-MU-011-000-006, February 1980.

<sup>3</sup> See footnote 2, page C-4.

the crater volume. A delphi was performed; the consensus estimate was that calculated crater volume is  $\pm 5$  percent of the true crater volume; i.e., this percentage accuracy index is expert opinion.

b. The procedures in this paragraph were developed by USAWES. Equation 3 was derived as follows: Figure C-3 is a cross-sectional view of a typical crater. The shaded area, region "R," represents one of the vertical plane regions on which depth measurements,  $D_j$ , were taken at discrete distances,  $r_j$ , from the crater center along a cardinal radius. Rotation of region "R" about the vertical axis, line AB, forms a solid of revolution whose volume approximates that of the crater. Its volume is calculated by summing the volumes of the concentric cylindrical shells swept out by the rectangular elements defined by paired sets of the measured data; e.g.,  $r_j$ ,  $D_j$ , and  $r_{j+1}$ ,  $D_{j+1}$ . In general, to obtain the volume of a cylindrical shell of depth  $D$ , inner radius  $r_j$ , and outer radius  $r_{j+1}$ , the volume of a cylinder of radius  $r_j$  is subtracted from that of one with radius  $r_{j+1}$ .

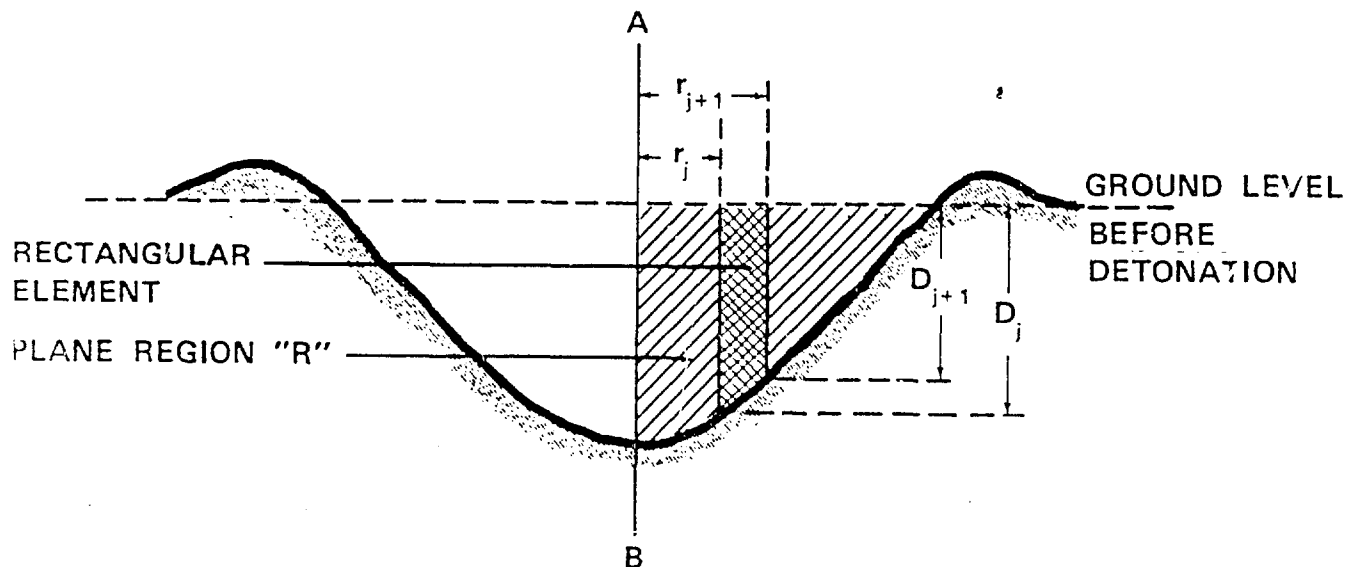

Figure C-3: Cross-sectional View of Typical Crater.

Volume of cylindrical shell:

$$\pi(r_{j+1}^2)D - \pi(r_j^2)D = \pi(r_{j+1}^2 - r_j^2)D \quad (1)$$

In lieu of the actual depth  $D$  which normally is not constant, the USAWES procedure uses the average of the measured depth at  $r_{j+1}$  and  $r_j$ ; namely,  $(D_{j+1} + D_j)/2$ .

Thus,

Volume of cylindrical shell:

$$\pi (r_{j+1}^2 - r_j^2) (D_{j+1}^2 + D_j) / 2 \quad (2)$$

Summing over all cylindrical shells, we have

Volume of crater:

$$\frac{\pi}{2} \sum_{j=1}^{n-1} (r_{j+1}^2 - r_j^2) (D_{j+1}^2 + D_j) \quad (3)$$

Where n equals the total number of data point sets,  $(r_j, D_j)$ .

c. Table C-1 is a USAWES-developed computer program which performs the calculations in paragraph b, above.

TABLE C-1. USAWES COMPUTER PROGRAM

```

10  REM  THIS IS THE WATERWAYS EXPERIMENT STATION CRATER VOLUME PROGRAM
20  DISP  "NUMBER RADIALS THIS CRATER"
30  INPUT N
40  FOR  I = 1 TO N
50  DISP  "ENTER P (# SURVEY POINTS)";
60  INPUT P
70  DIM  V(50),S(50),R(50),D(50),T(50)
80  PRINT "RANGE DEPTH"
90  DISP  "RADIAL DATA R,D";
100 FOR  J = 1 TO P
110 INPUT R(J),D(J)
120 PRINT R(J),D(J)
130 NEXT J
140 DATA 0,0,0,10,10,5,20,2,30,1
150 S(3) = 0
160 T(1) = 0
170 FOR  J = 1 TO P-1
180 Y(J+1) = ((D(J+1)+D(J))/2*(3.14*R(J+1) 2)
190 X = (D(J+1)+D(J))/2*(3.14*R(J) 2)
200 SC(J+1) = V(J+1)-X
210 T(J+1) = S(J+1)+T(J)
220 NEXT J
230 PRINT
240 PRINT
250 PRINT "CRATER VOLUME ESTIMATES BASED ON SINGLE RADIAL PLOT ROTATED 360°"
260 PRINT
270 PRINT "CRATER VOLUME CU FT =",T(P)
280 PRINT
290 PRINT

```

## TABLE C-1. USAWES COMPUTER PROGRAM (concluded)

```

300 PRINT
310 PRINT
320 DIM F(10)
330 F(1) = T(P)
340 NEXT I
350 F = 0
360 FOR I = 1 TO N
370 F = F+F(I)
380 NEXT I
390 V = F(N)*0.028817
400 PRINT "TOTAL CRATER VOLUME ESTIMATE IN CUBIC METERS",V
410 END

```

NOTES: 1. This program inputs standard measurement data (feet/inches), calculates volume in cubic feet, converts to cubic meters, and prints crater volume in standard and metric units.

2. When a different integer unit is selected, change program lines 270, 390, and 400 to determine experimentally correct volumes.

## 3. FIELD CRATER VOLUME CALCULATIONS

The following is an empirical procedure by which the evaluator can expediently obtain an approximation of actual crater volume ( $\pm 10$  percent) in the field. The formula for this field crater volume estimate is:

$$V = \pi \sum_{i=1}^{n-1} (1 + 2i) \frac{(D_i + D_{i+1})}{2} \quad (4)$$

a. Record predetonation ( $P_i$ ) and postdetonation ( $Q_i$ ) surface elevation data on the Elevation Profile Data Collection Sheet (form B-1), using one form for each data type.

b. Compute elevation differences ( $D_i$ ) and record on the Field Volume Calculations form (form B-2).

c. Perform the other calculations on form B-2.

d. Add crater volume segments  $\pi(1 + 2i) \frac{(D_i + D_{i+1})}{2}$  from ground zero

(GZ) to the crater wall. Record the total as Crater Volume (V) on Field Calculation Form.

2 July 1981

TOP 4-2-830

e. An example is provided to demonstrate the procedure for field crater volume calculations (figure C-4):\*

Given:	Predetonation Elevation	Postdetonation Elevation	Location
	At $i = 1$ , $P_i = 10$ ft	$Q_i = 3$ ft	GZ
	At $i = 2$ , $P_i = 9$ ft	$Q_i = 4$ ft	Intermediate Point
	At $i = 3$ , $P_i = 8$ ft	$Q_i = 5$ ft	Crater Wall

Find: Crater volume (V) of crater segments 1 and 2.

Solution:  $n = 3$

$$D_i = P_i - Q_i$$

$$D_0 = 10 - 3$$

$$D_0 = 7$$

$$D_1 = 5$$

$$D_2 = 3$$

$$V = \sum_{i=1}^{n-1} \frac{\pi (1 + 2i) (D_i + D_{i+1})}{2}$$

$$= 56.5 + 62.8$$

Answer:  $V = 119.3$  cubic feet ( $3.38 \text{ m}^3$ )

NOTE:  $n$  = Total number of depth measurements  
 $i$  = Horizontal distance from GZ to the point at which elevations are determined, along the radial being measured.  
 $P_i$  = Predetonation elevation at point  $i$ .  
 $Q_i$  = Postdetonation elevation at point  $i$ .  
 $D_i$  = Elevation differences ( $P_i - Q_i$ ).  
 $V$  = Total crater volume.

\* In this example, depth data were taken at 1-foot horizontal increments. If metric system is used, take data at 1-meter increments and use the same formulas.

$$i \quad P_i \quad Q_i \quad D_i \quad D_{i+1} \quad \frac{D_i + D_{i+1}}{2} \quad \frac{\pi}{2}(1 + 2i) (D_i + D_{i+1})$$

1	10	3	7	5	6	56.5
2	9	4	5	3	4	62.8
3	8	5	3	—	—	—

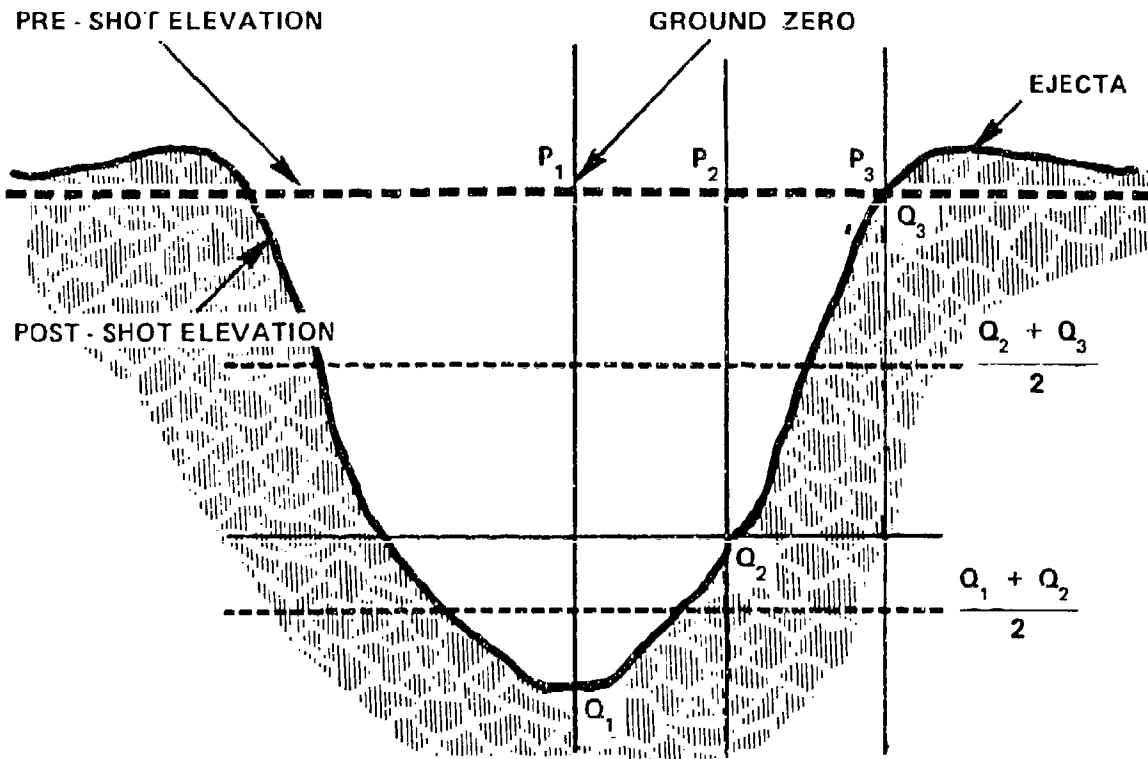

NOTE:  $P_i$  and  $Q_i$  need not necessarily coincide.

Figure C-4. Sample Field Volume Calculations Form and Diagram of Field Crater Used for Volume Estimating Procedure.

APPENDIX D. CRATERING DEFINITIONS

## 1. CRATER PROFILES

Figure D-1 identifies single-charge crater features, while figure D-2 locates a cross section.

## 2. PARAMETERS

Craters for barrier purposes are described in terms of four features which offer various degrees of impedance to vehicle mobility as a result of differences in soil strength, slope, and surface roughness. These features are illustrated in figure D-1 (see TOP 2-2-817, Tropic Testing of Vehicles).

The following definitions, most of which are illustrated in figure D-2, are commonly used in explosive excavation literature.

Apparent crater. Portion of the visible crater below the original ground surface elevation.

Apparent lip. Portion of the visible crater above the original ground surface elevation. It is composed of two parts: upthrust (true lip) and ejecta.

Charge burial depth. The emplacement depth at which the charge is fired.

Ejecta. Material permanently expelled from the true crater void by the explosion.

Fallback. Material disassociated by the explosion that has fallen back within the true crater void.

Optimum charge burial depth. The emplacement depth that produces the largest possible crater.

Row shot. A multiple explosion with the charges emplaced in a linear array (row of charges).

Row crater. A ditch or canal formed by the detonation of charges emplaced in row shot geometry.

Rubble. Material comprising the fallback and ejecta.

Rupture zone. The zone of blast-induced fractures and displacement from true crater boundary outward to the relatively undisturbed in situ material.

True crater. The boundary of the crater representing the limit of disassociation of the medium by the explosion.

Upthrust. Material that has been permanently displaced above the original ground surface elevation.

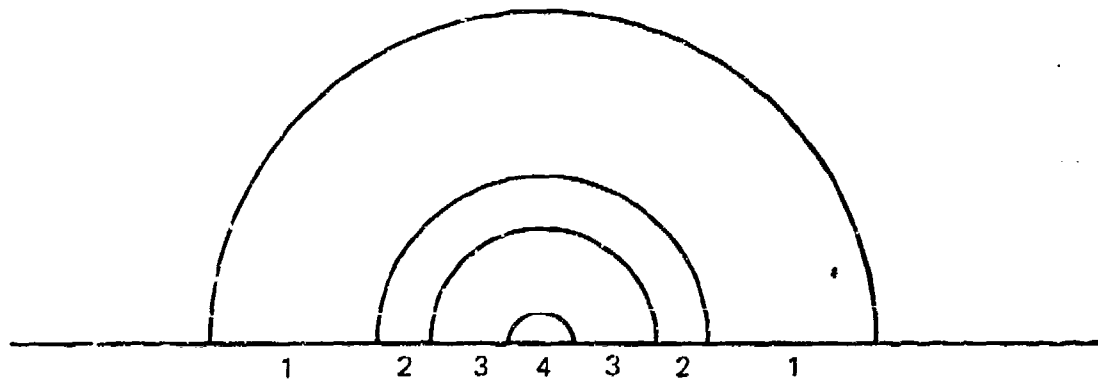

A. PLAIN VIEW

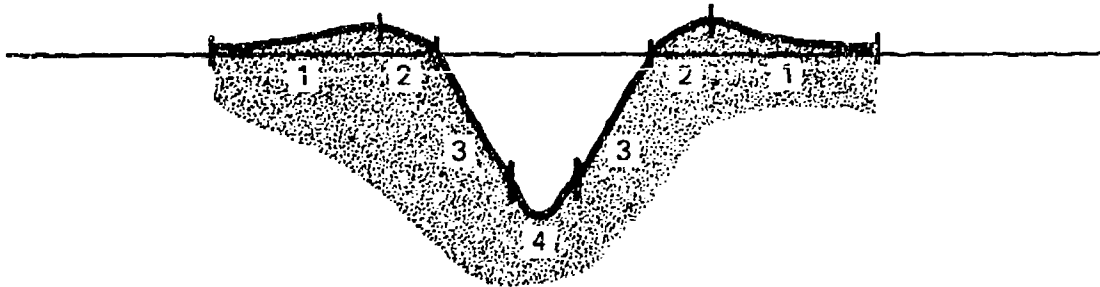

B. PROFILE SKETCH

Figure D-1. Schematic of Typical Crater Features Formed by a Single Charge.

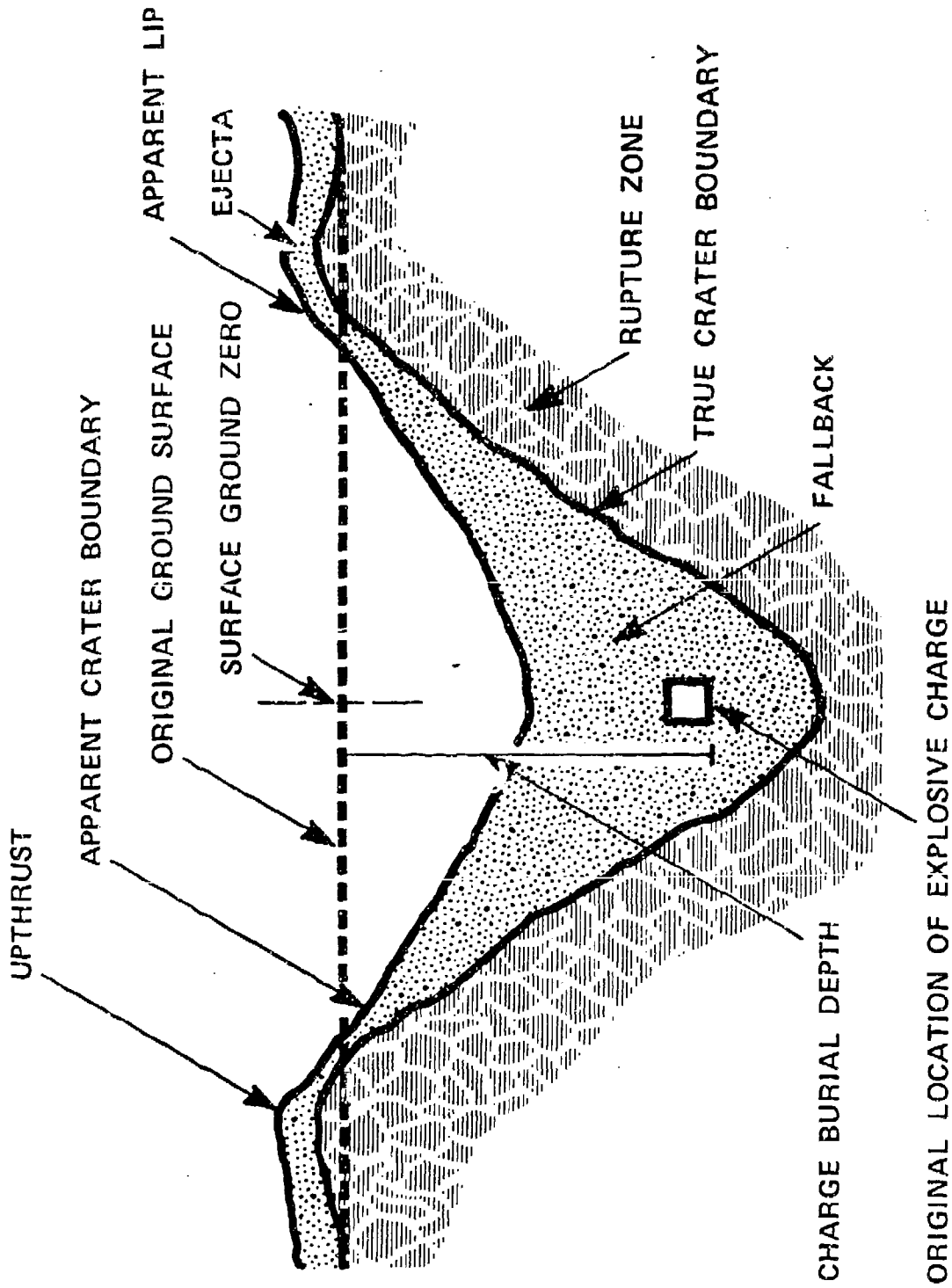

Figure D-2. Cross Section of Typical Crater Showing Nomenclature.