

AD-A104 916

HYDROLOGIC ENGINEERING CENTER DAVIS CA
DIGITAL SIMULATION OF AN EXISTING WATER RESOURCES SYSTEM. (U)
OCT 71 A J FREDRICH
HEC-TP-28

F/6 13/2

UNCLASSIFIED

NL

[1]
AD-A
03916



END
DATE
FILMED
10-81
DTIC

13

OCTOBER 1971
TECHNICAL PAPER NO. 28

AD A104916

DIGITAL SIMULATION OF AN EXISTING
WATER RESOURCES SYSTEM

by
AUGUSTINE J. FREDRICH

DTIC
SELECTED
OCT 2 1981

D

DTIC FILE COPY

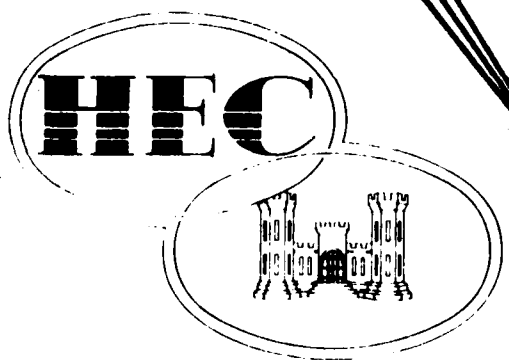

CORPS OF ENGINEERS
U. S. ARMY

THE HYDROLOGIC
ENGINEERING CENTER

- research
- training
- application

DTIC
Approved for public release
Distribution unlimited

Papers in this series have resulted from technical activities of The Hydrologic Engineering Center. Versions of some of these have been published in technical journals or in conference proceedings. The purpose of this series is to make the information available for use in the Center's training program and for distribution within the Corps of Engineers.

UNCLASSIFIED

SECURITY CLASSIFICATION OF THIS PAGE (When Data Entered)

REPORT DOCUMENTATION PAGE		READ INSTRUCTIONS BEFORE COMPLETING FORM
1. REPORT NUMBER	2. GOVT ACCESSION NO.	3. RECIPIENT'S CATALOG NUMBER
1 Technical Paper No. 28	AD A104916	
4. TITLE (and Subtitle)		5. TYPE OF REPORT & PERIOD COVERED
6 DIGITAL SIMULATION OF AN EXISTING WATER RESOURCES SYSTEM,		6. PERFORMING ORG. REPORT NUMBER
7. AUTHOR(s)		8. CONTRACT OR GRANT NUMBER(s)
1 Augustine J. Fredrich		14 HEC-ITP-00
9. PERFORMING ORGANIZATION NAME AND ADDRESS		10. PROGRAM ELEMENT, PROJECT, TASK AREA & WORK UNIT NUMBERS
U.S. Army Corps of Engineers The Hydrologic Engineering Center 609 Second Street, Davis, CA 95616		11
11. CONTROLLING OFFICE NAME AND ADDRESS		12. REPORT DATE
(12) 35		October 1971
14. MONITORING AGENCY NAME & ADDRESS (if different from Controlling Office)		13. NUMBER OF PAGES
		31
		15. SECURITY CLASS. (of this report)
		Unclassified
		15a. DECLASSIFICATION/DOWNGRADING SCHEDULE
16. DISTRIBUTION STATEMENT (of this Report)		
Distribution of this publication is unlimited		
17. DISTRIBUTION STATEMENT (of the abstract entered in Block 20, if different from Report)		
18. SUPPLEMENTARY NOTES		
Presented at IEEE Joint National Conference on Major Systems.		
19. KEY WORDS (Continue on reverse side if necessary and identify by block number)		
Simulation analysis, Digital computers, Operations research, Reservoir operation, Water resources, Basins, Hydrologic Data, Flood Control, Hydroelectric power.		
20. ABSTRACT (Continue on reverse side if necessary and identify by block number)		
A review of the operation of the existing reservoir system in the Arkansas, White and Red River basins was presented. The system is composed of 23 reservoir projects. Presently, flood control, navigation and hydroelectric power production are considered the primary demands. Digital simulation was used to analyze and evaluate the operation of the system. The procedure involved postulating an operation plan, operating the simulation model to determine the results of the plan, evaluating the results in terms of the desired operation objectives. (CONTINUED)		

4011181

UNCLASSIFIED

SECURITY CLASSIFICATION OF THIS PAGE(When Data Entered)

20(CONTINUED)

modifying the proposed plan to rectify any errors or inconsistencies in the policy as indicated by the results of the simulation study and repeating the process until the desired objectives were realized. Basic physical, climatologic and hydrologic data were collected, analyzed and prepared for use in a computer study. It was concluded that simulation is an effective tool for studying the operation of existing water resource systems, however, further research must be done to identify explicit operation objectives and identify and quantify parameters to measure whether the objective is being satisfied.



Accession For	
NTIS GRA&I	<input checked="" type="checkbox"/>
DTIC TAB	<input type="checkbox"/>
Unannounced	<input type="checkbox"/>
Justification	
By _____	
Distribution/	
Availability Codes	
Dist	Avail and/or Special
A	

SECURITY CLASSIFICATION OF THIS PAGE(When Data Entered)

DIGITAL SIMULATION OF AN EXISTING WATER RESOURCES SYSTEM⁽¹⁾

By

Augustine J. Fredrich⁽²⁾

INTRODUCTION

Although present concern for environmental and sociological effects of water resources projects might lead one to believe that the days of extensive development of water resource systems have passed, the need for techniques to analyze and evaluate the performance of existing systems can be expected to continue for quite some time. In fact, the increased awareness of the populace and the policymakers is resulting in a greatly increased need for studies to: review and update operational plans for existing systems; establish base conditions for comprehensive land and water resource planning in basins where there are existing developments; and define the economic, social, environmental, legal, and functional effects of changes in criteria or priority of service among water uses.

The rapidity with which changes occur in modern society and the diversity of interests among the various segments of society have stimulated the operating entities to expand the scope of operation objectives and consider a wider range of point-of-view in making operation decisions. Consequently, the studies upon which the operation decisions are based

(1) For presentation at the IEEE Joint National Conference on Major Systems.

(2) Chief, Research Branch, The Hydrologic Engineering Center, U. S. Army Corps of Engineers, Davis, California.

must be more comprehensive in order to identify the degree of interaction among water uses, provide information on competitive and complementary aspects of the interactions and direct attention toward problems which have not been fully considered in past studies.

During the past few years many techniques for developing optimal operating plans have been described in the technical literature, but it seems doubtful that any of the techniques would be completely satisfactory for use in evaluating system operation plans for a large, complex, existing system. In addition to the problems caused by the necessity for simplification, linearizations and generalizations to make the existing system mathematically tractable, there are gross inequities in the reckoning of the worth of the output for some of the authorized and approved water uses. These inequities result from political, legal, institutional and social considerations, and their effect in an optimization process would likely be the production of a politically or institutionally infeasible operation plan. In order to avoid the problems inherent in attempting to quantify and handle explicitly some of these constraints, it appears that digital simulation can be used to analyze and evaluate the operation of the system, with the idea that a satisfactory operation plan might be developed through successive incremental improvements in operation policy.

By postulating an operation plan, operating the simulation model to determine the results of the proposed plan, evaluating the results in terms of the desired operation objectives, making modifications to the proposed operation plan to rectify any errors or inconsistencies in the

policy as indicated by the results of the simulation study, and repeating the process until the desired objectives are realized, an operation plan can be developed to satisfy any feasible operation objectives. The probability that an optimal or near-optimal plan can be developed through successive incrementally improved simulations is dependent on three factors: the ability of the engineer or engineers conducting the study to perceive and formulate operation objectives that accurately reflect all of the requirements and services that must be satisfied by the system; the ability of the engineer or engineers conducting the study to evaluate the results of the simulation studies and formulate improved operation rules that would produce the desired results; and the degree of fidelity with which the simulation model being used reproduces physical occurrences in the prototype system. This paper describes some of the efforts expended thus far with respect to perception and formulation of operation objectives and evaluation of study results.

THE ARKANSAS-WHITE-RED RIVERS SYSTEM

The existing reservoir system in the Arkansas River, White River and Red River basins illustrates very well many of the complexities that are encountered in studying the operation of an existing system. As shown on plate 1, the system is composed of 23 reservoir projects located in the three river basins. Although the river basins are hydraulically independent, they are electrically interconnected so that system power demands could theoretically be met by any one of the 19 power projects in the three basins. In addition to generation of hydroelectric power,

the projects provide flood control, water supply and navigation and have operation requirements to modify and enhance fish and wildlife environment, water quality, and water-based recreation. Not all purposes are served by each project, but almost all projects are operated to provide direct service to at least two water uses.

There are no physical facilities for diversion of water between basins, so all demands for water must be met by projects within the basin where the demand occurs. Legal and institutional constraints limit the services which can be provided from some of the reservoirs so that it is not always possible for all projects which have the physical capability to meet a given demand to do so.

The reservoir projects range in size from 4,350,000 acre-feet of usable multiple-purpose storage to 19,000 acre-feet of power pondage. The total installed capacity of the 19 hydroelectric projects in the system is almost 2 million kilowatts. Water supply, fish and wildlife, water quality, and water-based recreation are at present less important than flood control, navigation, and power production. However, the pressures for additional attention to recreation and water quality are increasing and many operation decisions are already based, either explicitly or implicitly, on requirements for these two purposes.

Three independent entities own and operate the projects, and a fourth agency is directly involved in operation decisions because of power marketing considerations. The Federal government (Corps of Engineers) owns and operates 20 of the 23 projects, and a separate Federal agency arranges for marketing of the power output of the 16

Federal power projects. A state agency owns and operates two of the 23 projects, both of which have power installations, and the remaining project which also has a power installation is owned by a private utility.

The multiple ownerships create problems in analyzing the operation for any purpose, but the problems involved in the analysis of hydropower operation are vividly illustrative of the complexity which results from the addition of institutional and legal constraints to the physical and hydrologic constraints that exist naturally in the system. The power projects are interconnected and their outputs marketed in a way which, for purposes of an operation study, creates three power subsystems which must be analyzed separately, but simultaneously. As shown on plate 2, the Bull Shoals and Table Rock projects are electrically interconnected. The output from these two power projects is marketed by the Federal marketing agency to an area which has a seasonally varying demand with a substantial peak demand during the winter. The non-Federal projects (Ozark Beach, Markham Ferry and Pensacola) are operated by their owners, and their output is not marketed by the Federal marketing agency. Consequently, they form a system with water outputs that contribute to the Federal projects, but with power outputs that do not contribute to the Federal power supply. The remaining 14 power projects are electrically interconnected, and they comprise a third system. The output from these projects is marketed in an area with a seasonally varying demand with a substantial peak demand in the summer. Furthermore, a portion of the output of the Denison project is marketed to utilities in Texas which are not connected to the utilities in the major marketing area. Therefore,

this output must be deducted from the total power output of Denison before calculating Denison's contribution to the main system.

The bulk of the power demand in the market area is met by thermal generation which is not Federally owned or operated, and the hydroelectric generation is used primarily to meet peaking demands. More than 400,000 kilowatts of the 1,112,000 kilowatts of installed capacity in the 14-plant Federal system is located at navigation lock and dam projects on the Arkansas River. The storage at these projects is only adequate to sustain peaking generation for daily or, at most, weekly cycles. Since the storage volume upstream of these essentially "run-of-river" projects is not large with respect to the water required to provide energy to support this amount of installed capacity, and since there are no physical facilities for diversion of water from the large storage projects in the White and Red River basins, the power generation allocations among the basins must be carefully planned to fully utilize the available streamflow and meet the system power demands. The development of operation criteria to accomplish this allocation effectively is a major part of the problem of operating the hydroelectric system.

In arranging to market the hydroelectric power it is necessary to provide for the capability to purchase thermal energy to support the hydroelectric capacity during periods of deficient streamflow. Since the thermal purchases represent a cost which must be deducted from the revenues obtained from the sale of hydroelectric energy, it is not sufficient simply to maximize the hydroelectric energy production. Instead, the hydroelectric generation must be integrated with the thermal purchases in a way which

minimizes the thermal purchases without endangering the capability of the hydroelectric plants.

USE OF SIMULATION IN THE A-W-R SYSTEM STUDY

Simulation may be described as the process of duplicating the essence of a system or activity with respect to some predetermined objective without actually attaining reality itself. This description implies that it is not necessary to duplicate all facets of a system in a simulation study, but rather that the study should only duplicate those facets which are essential to understanding the system's behavior with respect to the study objectives. Thus, in a study of system operation it is unlikely that detailed modeling of structural aspects of the components would be necessary, just as it is unlikely that detailed modeling of water quality parameters would be required in simulating the structural behavior of a project. Consequently, it is important to define as precisely as possible the scope of the simulation study and the study objectives.

The use of simulation as a tool in studying the operation of reservoir projects in the Arkansas, White, and Red River basins is not new. For at least 20 years various simulation studies using handcrafted simulation models (i.e., manual routing studies) have been conducted by the Little Rock and Tulsa District of the Corps of Engineers to evaluate the operation of individual projects and systems of projects. What is new, however, is the scope and complexity of the present simulation study. Historically, studies of the projects of the A-W-R system have been

limited in both scope and objective. For example, the White River basin projects have been studied as a system with respect to potential for power production during adverse streamflow conditions. The limitations here are fairly obvious: only the White River projects, primarily with respect to hydropower production, and only for adverse streamflow conditions. The reasons for the limitations are typical and valid, but perhaps not so obvious. First, the availability of computer hardware and usable simulation models has not been conducive to pursuit of a study with comprehensive scope or objectives. Secondly, data have not always been available to permit consideration of all important facets. Thirdly, the concern and interest of the engineering personnel and society as a whole did not encourage study of all facets that are now important. And finally, manpower and budget constraints have, in effect, limited the scope of past studies.

During the past few years, events have occurred that have increased the feasibility of comprehensive studies of water resources systems. Each of the constraints listed in the previous paragraph has been relaxed somewhat in recent years, and is now possible to think in terms of a study which will permit consideration of all completed and authorized projects operating for all authorized and approved purposes. Although it is impossible to fully consider all purposes at the present time (primarily because of a lack of data and information necessary to define the impact of operation decisions on some purposes), it appears that the capability exists to study many facets of multiple-purpose operation that are now vitally important, but which have not been studied in the

past. In fact, it appears that the capability exists to develop operation rules that would result in significant improvements in the system operation, but which might not be amenable to implementation because of a lack of institutional arrangements between Federal, state and private ownerships in the basin.

ORGANIZATION OF THE SIMULATION STUDY

As soon as the scope and objectives of the study of operation of the A-W-R system were defined it was obvious that the simulation model could be developed only through use of a digital computer. The system itself was analyzed to develop limits and formulate criteria for the study. Basic physical, climatologic, and hydrologic data were collected, analyzed and prepared for use in a computer study. Because of the complexity of developing operation procedures for large multiple-purpose systems it was decided that the analytical capability developed would probably only permit a somewhat restricted study of the system as a whole--incorporating as much detailed information as possible for each authorized and approved purpose. It was recognized that some aspects of the system operation would require analyses that could not be accomplished with existing or proposed comprehensive digital models of water resource systems.

A program developed by The Hydrologic Engineering Center was selected for the system study because it appeared to have the capability to consider most of the factors that appear to be important for development of operation rules for the A-W-R system. Several computer simulations

of the system were made to: (1) test the validity of the program for use in studying the A-W-R system; (2) educate study participants in the techniques of computer simulation models and familiarize participants with the capabilities of the specific program; and (3) provide the opportunity to modify and improve the program to fit the specific conditions of the existing A-W-R system. These simulations demonstrated that the HEC program was suitable for simulation of most important conservation purposes of the A-W-R system.

A review of the initial computer simulation of the A-W-R system indicated that the program would be most useful for comparing alternative operation plans when the most important factors affecting the various plans could be considered, either explicitly or implicitly, through criteria and data for a monthly routing interval. In the opinion of a majority of the study participants, the operation requirements for purposes such as flood control, water quality enhancement and peaking power operation, which usually require detailed short-period analysis to accurately define their effect, were either relatively unimportant with respect to the overall system operation plan or were adequately simulated for comparative purposes in the monthly routing interval. After the program was adopted for use in the A-W-R system studies, it was decided that several system simulations or runs would be made to attempt to identify the nature of a feasible system operation plan and to determine, insofar as possible, the characteristics of the specific operation procedures that would constitute the plan.

The operation of the system is studied by simulating its performance through 45 years of historical hydrologic data. The range of hydrologic events during this period is believed to be such that it includes representative critical conditions for evaluating alternative operating plans and gives a reasonable approximation of the long-term average output of the system.

THE SIMULATION MODEL

Basically the computer program being used in the A-W-R system study does essentially the same type of computation that has been done with handcrafted simulation models in the past. Only the degree of refinement, speed of computation, and degree of complexity have been increased. In the computer simulation model (program) it is possible to consider many more factors than could be considered in traditional routing studies, to consider each factor in much more detail than it has been previously considered, and to study a much larger system than could previously have been studied.

Generally the computer program requires that the location of each component in the system (i.e., reservoir, power plant, downstream control point for flood control, etc.) with respect to the other components in the system be specified and that operation requirements for all pertinent purposes be specified at each reservoir and control point where the purpose is significant. In general these requirements must be specified in terms of a flow rate such as release in cfs or total river flow in cfs.

However, it is also possible for requirements to be specified in terms of storage volume remaining in a reservoir and kilowatt-hours of electrical energy production. Since these three parameters do not always lend themselves to direct relationships with some operation objectives, it is sometimes necessary for relationships to be developed externally. For example, navigation operation may be dependent upon river stage at a certain location. Although the program will not accept river stage as an input parameter, the stage-discharge relationships at the location can be developed externally, and the operation requirement in terms of discharge can be calculated and provided as input to the program.

In addition to specifying the operation requirements for each purpose at each component of the system, it is necessary to describe the physical relationships and constraints that control the operations of the component (for example, outlet capacity, area-capacity relationship, installed capacity of powerplants, spillway elevation-discharge relationships, conduit invert elevations). Finally, if the system operation is to be dependent upon the relative state of components (for example, the generation of power at a powerplant to contribute to meeting a system power requirement being dependent upon the reservoir storage at the powerplant as compared to other powerplants in the system) operation rules must be specified. All of the operation rules and operation requirements and some of the constraints can be varied from period to period, if desired (for example, power requirement of 2000 megawatt-hours in January, 2700 megawatt-hours in February, 2500 megawatt-hours in March, etc.). For the A-W-R study it was also necessary for the program to

simulate in a crude fashion the operation of a thermal generation system, because the relationship between the hydroelectric and thermal generation must be considered.

The computations performed by the program are based on the principle of continuity as expressed by the equation

$$S_i = S_{i-1} + I_i - Q_i - E_i$$

where,

S_i = reservoir storage at the end of the current period, i

S_{i-1} = reservoir storage at the end of the previous period, $i-1$

I_i = inflow volume during period i

Q_i = release volume during period i

and E_i = evaporation volume during period i .

This basic equation, when I , Q , and E are properly defined, is appropriate for storage accounting where the length of the period i is long enough that the travel time through the reservoir is insignificant. It should be noted that proper definition of I implies that all diversions into the reservoir and releases from upstream reservoirs must be added to the natural inflow to obtain the inflow volume; that proper definition of Q implies that all diversions out of the reservoir, leakage from the reservoir, and releases for different purposes are added together to obtain the total release volume; and that E must reflect the gain or loss in reservoir storage volume that would occur as a result of net evaporation (evaporation minus precipitation) over the impoundment area during the period.

Power calculations are based on the equation

$$GE_i = .08464 Q_i \cdot h_i \cdot e_i$$

where

GE_i = energy in kilowatt-hours generated during period i

Q_i = flow in cfs through the generating units during period i

h_i = effective head on the turbine during period i

e_i = efficiency of the generating units during period i

This equation is appropriate for use when Q_i has been defined as only that part of the release volume which passes through the generating units, when h_i is defined as the head which exists during the period i (calculated by subtracting tailwater elevation and head loss from the reservoir surface elevation), and when e_i reflects the average overall station efficiency during period i . The calculation of head is based on the elevation corresponding to mean reservoir storage for the current period (average of the beginning and ending reservoir storage) and the tailwater elevation is specified as either a constant value or as a function of the mean release rate for the period.

The specific components of the entire system that contribute to meeting a system requirement (such as system power requirement, a stream-flow requirement at a point downstream of several reservoirs, or a flood control limitation at a downstream point) are specified in a manner which insures that only those projects which should (with respect to legal or institutional ability as opposed to physical capability) contribute to meeting the system requirements are permitted to do so. The system requirements can either override or supplement the individual project

requirements according to the study requirements. Operation rules are specified to implement the desired interaction among projects in meeting the system demand.

The simulation model operates by considering the water and power requirements at each pertinent point in the system in a sequential fashion, beginning at an upstream point and moving in a downstream direction through each river basin. The release required to meet the at-site requirements for all pertinent purposes is determined by evaluating each operation requirement and all physical and operation constraints at each site. Also, an index of the relative state of each reservoir (usually a function of reservoir storage) is determined according to the specified operation guides. After all at-site requirements have been met at all points in the system (or shortages declared if water is not available) the various system requirements are examined to determine whether additional water releases or power generations will be needed to satisfy the system demands. If so, the additional needs are proportioned among projects that have been specified to be available for meeting that system requirement in accordance with the relative state of the projects as evidenced by the indices previously computed. The additional releases are added to the previously computed releases for meeting at-site requirements, and the system and at-site requirements are thus met (or system and at-site shortages are declared if water is not available). This process is repeated for each period of the study, with the ending state of the projects in the system for the current period being the beginning state for the next period.

Results from the successive applications of these calculations on a period-after-period basis are recorded for all points in the system (including nonreservoirs) by an accounting procedure which simply accounts for the movement of the water through the system by using the specified relative location of the reservoirs and downstream control points. By adding releases to natural streamflow to obtain total streamflow, and by adding inflows to storage volume and subtracting releases from storage volumes the state of any component and the flow at any point in the system can be calculated. As these results are calculated they are stored and finally printed out, on a project-by-project basis, to produce a continuous record of inflow, storage, outflow, power generation, and other pertinent data. These results may be rearranged in many ways to serve various needs in analysis or evaluation of the system operation.

Through careful examination and evaluation of the results, the response of the system to the specified operation requirements and the specified operation rules can be determined. If the response of the system is satisfactory and if there are no deficiencies or inconsistencies in the operation plan, the results can be used as a basis for implementing the operation plan. If, on the other hand, the response of the system is not satisfactory, the results must be examined further in order to determine the nature of changes in the operation plan to produce a satisfactory response. When the contemplated changes have been identified they must be transformed into specific operation rules, and the entire simulation

study must be repeated to determine the response of the system to the modified rules. The entire process must be repeated until a satisfactory system operation plan emerges.

The model also has the capability for relating hydrologic or physical parameters to economic returns through the use of benefit functions. Benefit functions can be specified separately for each reservoir and downstream control point and for each different purpose, if necessary. Furthermore, the benefit functions can vary seasonally if this is necessary to reflect the seasonal variations in value of water or storage for some purposes. At the end of each simulation run the parameters such as regulated streamflow, power production and reservoir storage are applied to the appropriate benefit functions to obtain an indication of the relative economic returns which could be expected from the operation plan used in the study.

STUDY RESULTS

The study of the operation of the A-W-R system is a continuing study which will require that objectives and criteria be updated periodically to reflect the changes in priority of water use. Consequently, there are no final results in the usual sense. However, analyses conducted during the past 2 years have contributed significantly to understanding of the system, given insight into the nature of potential improvements in system operation rules, and provided information which can be used to improve the operation efficiency of individual projects in the system.

Coordination of hydroelectric generation and purchases of thermal energy to meet Federal contractual commitments for power supply requires that time and quantities of thermal energy purchases by the Federal marketing agency be based on the relative state of the reservoir system. Supplementary thermal energy is purchased only when it is needed to augment the energy produced by the hydroelectric plants or when anticipation of deficient streamflows dictates that purchases should be made to avert potential future shortages in hydroelectric energy production.

Operation guides of the type shown in plate 3, based on the performance of the system during the historical hydrologic record, are needed to determine the timing and quantities of thermal purchases. System energy in storage, the parameter used on plate 3 to indicate the state of the system in making the decision to purchase energy, is believed to be a better indicator than, say, water in storage in the system. However, it is anticipated that problems may arise with respect to this parameter because of the run-of-river plants on the Arkansas River being unable to avail themselves of the benefits of storage on the White and Red Rivers. It is anticipated that future studies may require modification of this parameter to reflect the consequences of the inequitable storage distributions. The application of weighting factors to the computed energy in storage in each basin before developing a system composite value for energy in storage would be one way of modifying the parameter.

A major problem in the study thus far has been an inability to quantify operational objectives for the existing system. Because

comprehensive studies have not been performed in the past, the existing set of objectives may be incomplete or inharmonious. The conflicts are resolved by obtaining from the operating entity as much information as possible, simulating the operation for a recent historical period using that information, comparing the results with the actual operation, questioning the operating entity about discrepancies, revising the operation criteria and resimulating the operation. The process must be repeated until a reasonable simulation is obtained. This is, however, a valuable part of the overall study because it forces the engineer to identify and quantify operation objectives. In cases where the current operating plan has evolved from piecemeal revisions of old policies this is a very valuable exercise.

Another related problem is the lack of information on criteria and constraints associated with complementary and competitive interactions among water use. Again, the absence of this information can be attributed primarily to the fact that past studies were less comprehensive and did not require this type of information. The current studies have been very valuable from the standpoint of indicating specifically which areas need additional study and consideration.

Another major problem associated with the study of the A-W-R system is the tremendous volume of output generated in the study. Plates 4 and 5 illustrate the output of the program for 1 year of data in a simple system with three reservoirs and a single downstream control point. Plates 6 and 7 illustrate some of the end-of-run summary information that can be obtained. It can be seen that the output from a single simulation run

for a complex system such as the A-W-R system can easily amount to a thousand pages or more. The need for numerous simulation runs rapidly multiplies the output volume.

It is relatively easy to produce in a week or two far more output than can be intelligently analyzed by many people in a year or so. The roots of the problem and the key to its solution are in the presimulation planning. Carelessly thought-out, limited objective studies with poorly documented criteria almost always result in studies of only limited utility. These studies frequently are not worth documenting and consequently a valuable link in a chain of studies can be lost--making it impossible to trace the logic of the sequence of studies after some time has passed. In early stages of a simulation study the proper answer to any question always seems to be "perform another simulation." However, as the unanalyzed or partially analyzed studies pile up, it becomes evident that this is not only not the proper answer--it is often a very poor answer. There is no substitute for a well-planned, properly executed, carefully documented simulation study. Resisting the temptation to perform analyses as rapidly as possible leads to the discovery that a little planning for a single simulation analysis can answer many questions and save immeasurable time and manpower. Also, a little forethought in identifying output parameters of value or of interest is well worthwhile. It is much easier and much less costly to have the computer calculate and print out parameters of interest than to have to develop them from the output by hand.

SUMMARY

Efforts expended to date in the A-W-R study and in other similar water resource system studies indicate that simulation is an effective tool for studying the operation of existing water resource systems. However, much remains to be done before the power of simulation models can be fully utilized and the benefits of the simulation study fully realized. First, much work must be done to identify explicit operation objectives and identify and quantify parameters that can be used to measure whether the objective is being satisfied. Consistent and comparable measures of value for competing water uses must be developed if rational choices are to be made when water deficiencies do not permit full service to all demands.

Better techniques are needed for documenting data, assumptions, and criteria used in the simulation studies and for documenting the study sequence itself. Only when these techniques are more fully developed will the simulation study adequately serve as the basic reference for developing and implementing an operation plan for a reservoir system. Also, more thought must be devoted to determining in advance what output is needed and its form and format so that selectivity can be used to suppress unwanted and unneeded results. This must be done in order to reduce the output volume to a manageable level in studies of large systems. This implies that simulation models will possess the capability for user-controlled selective output, and presently available models are generally woefully inadequate in this respect.

Finally, it would be desirable for the simulation model to possess some capability for self-optimization in order to reduce the amount of human intervention that is required to obtain an optimal or near-optimal operation plan. However, the development of self-optimization capability must, of necessity, follow some of the developments previously mentioned such as quantification of operation objectives and comparable measures of value for alternative water uses.

ACKNOWLEDGMENT

The digital simulation model described herein was developed by Mr. Leo R. Beard, Director of The Hydrologic Engineering Center. The A-W-R system operation study has been conducted jointly by The Hydrologic Engineering Center and the Southwestern Division, Little Rock District and Tulsa District offices of the U. S. Army Corps of Engineers. The views expressed herein are those of the author and do not necessarily reflect the policies and practices of the Corps of Engineers.

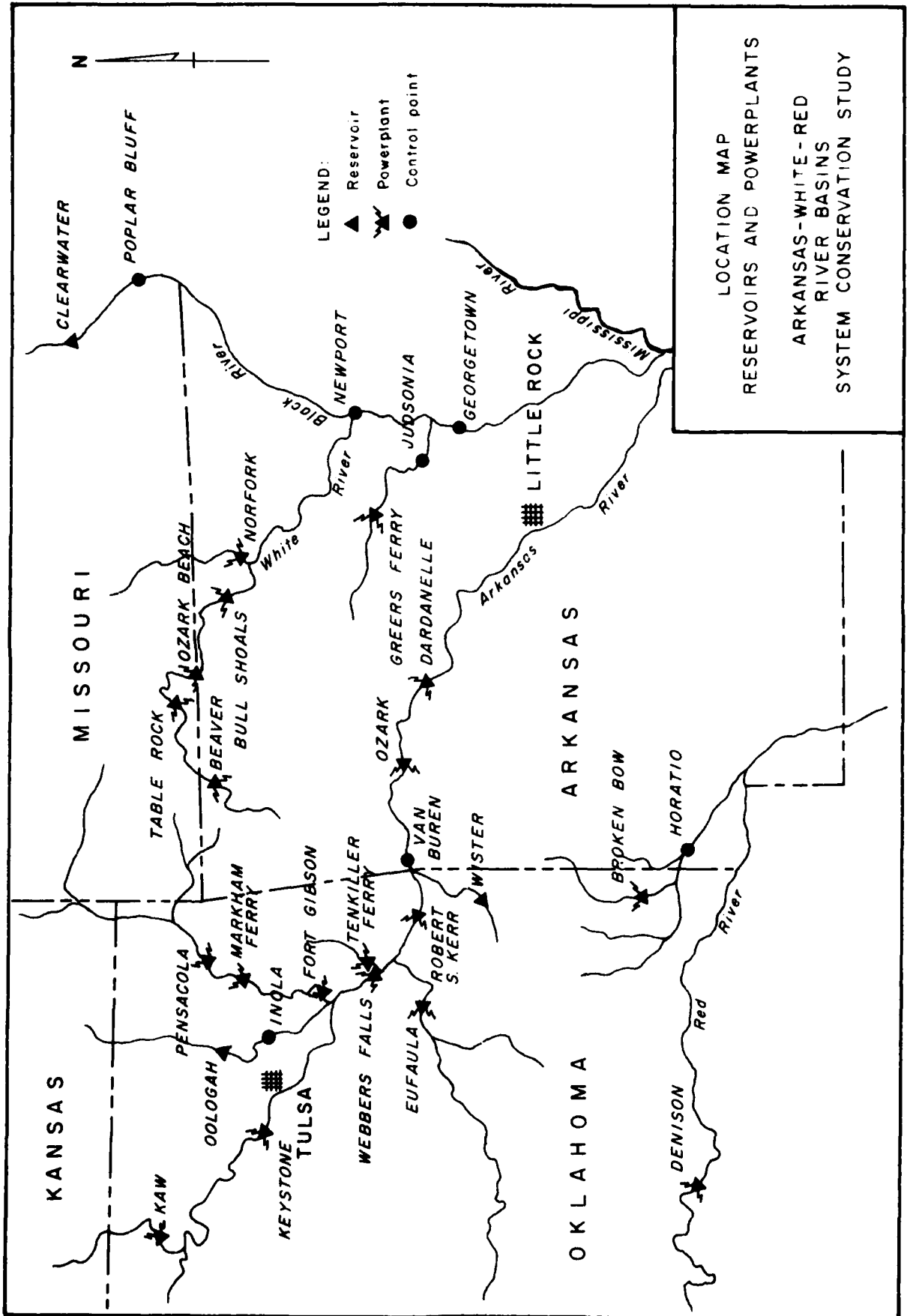
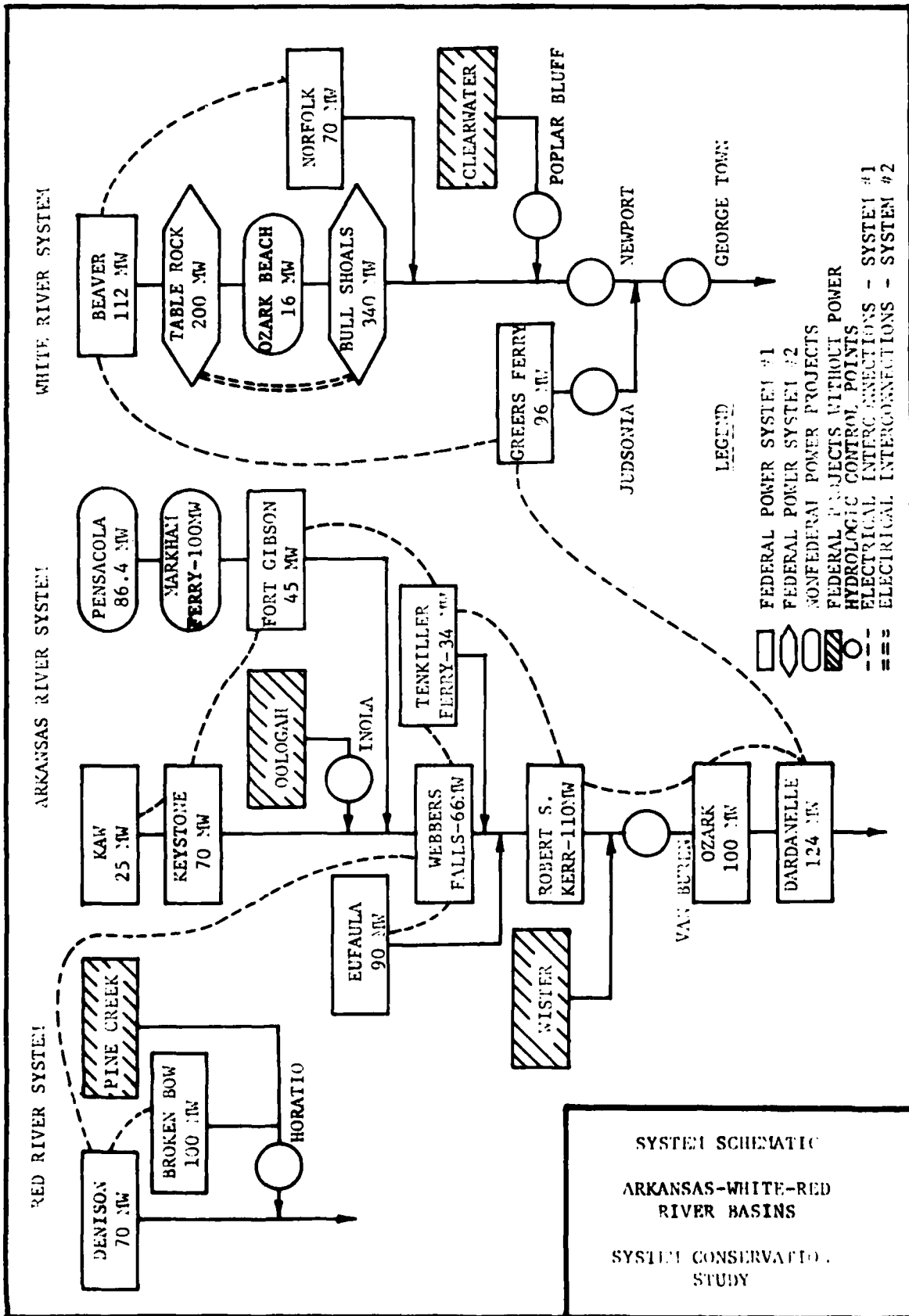
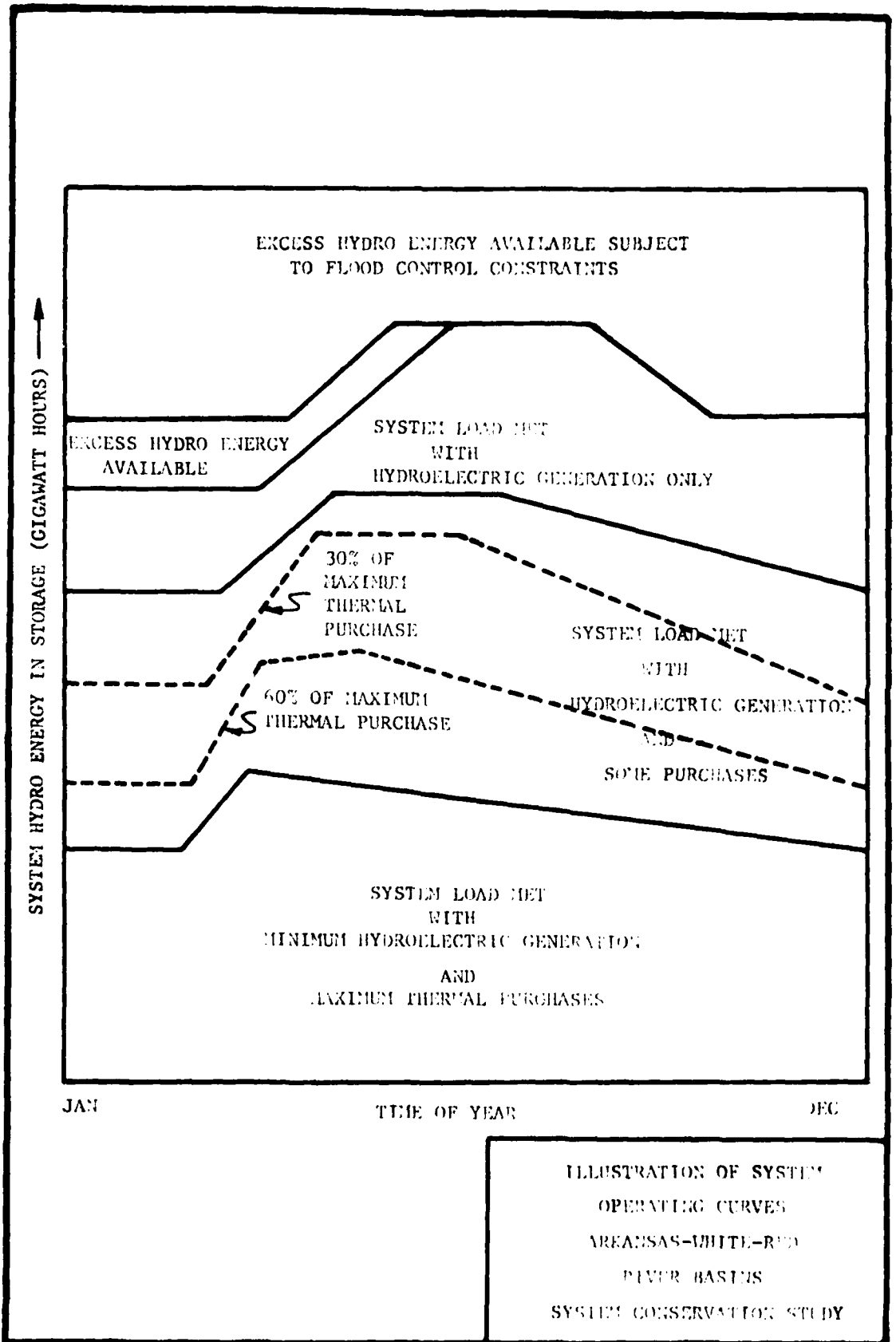

PLATE I





ALL FLOWS IN CFS, STORAGES AND EVAP IN ACFT, AND POWER IN THOUSAND KWH

1 RESERVOIR A	YR 1927	AVG	LEAKAGE 1 2 4													
			JAN	FEB	MAR	APR	MAY	JUN	JUL	AUG	SEP	OCT	NOV	DEC		
LOC FLW	1600.	1269.	1600.	2600.	1610.	1275.	1275.	1680.	1570.	1570.	520.	345.	433.	500.	2050.	1185.
UNREG	1600.	1269.	1600.	2600.	1610.	1275.	1275.	1680.	1570.	1570.	520.	345.	433.	500.	2050.	1185.
INFLOW	1600.	1269.	1600.	2600.	1610.	1275.	1275.	1680.	1570.	1570.	520.	345.	433.	500.	2050.	1185.
EOP STR	319718	356000	356000	353255	356000	356000	356000	356000	356000	356000	338000	292567	162868	107000	213471	283776
EOP EL	1528.20	1543.29	1543.29	1542.27	1543.29	1543.29	1543.29	1543.29	1543.29	1543.29	1535.87	1516.82	1453.01	1414.00	1480.86	1513.10
EVAP	0.	0.	0.	0.	0.	0.	0.	0.	0.	0.	1282.	889.	388.	186.	0.	0.
REQ PWR	87600.	5290.	7440.	7200.	7440.	7200.	7440.	7200.	7440.	7200.	7440.	7440.	7200.	7440.	7200.	7440.
SYS 1	108483.	8333.	8333.	8333.	8333.	8333.	8333.	8333.	8333.	8333.	9931.	10120.	10600.	10120.	8271.	8333.
POWER	228220.	0.	29520.	27683.	21729.	27879.	25836.	13460.	17493.	37044.	15882.	0.	0.	0.	4118.	6826.
SHORTGE	18384.	7440.	0.	0.	0.	0.	0.	0.	0.	0.	0.	0.	0.	0.	0.	7720.
SYS SRT	21241.	8333.	0.	0.	0.	0.	0.	0.	0.	0.	103	401	401	202	403	403
CASE	403	403	403	403	403	403	403	403	403	403	103	401	401	202	403	403
LEVEL	6.82	7.00	7.00	6.89	7.00	7.00	7.00	7.00	7.00	7.00	6.00	5.47	3.19	1.00	6.29	6.64
CSV REL	794.	0.	550.	485.	513.	707.	1113.	792.	1069.	2606.	1406.	1406.	1406.	1406.	261.	42.
RIV FLW	1176.	0.	1947.	1610.	1308.	1624.	1553.	792.	1069.	2606.	1406.	1406.	1406.	1406.	261.	42.
DES FLW	0.	0.	0.	0.	0.	0.	0.	0.	0.	0.	0.	0.	0.	0.	0.	0.
SHORTGE	0.	0.	0.	0.	0.	0.	0.	0.	0.	0.	0.	0.	0.	0.	0.	0.

2 RESERVOIR B	YR 1927	AVG	LEAKAGE 2 4											
			JAN	FEB	MAR	APR	MAY	JUN	JUL	AUG	SEP	OCT	NOV	DEC
LOC FLW	2760.	2014.	4550.	2710.	1865.	1940.	1750.	900.	370.	642.	1160.	3670.	2095.	
UNREG	4360.	3283.	7150.	4320.	3140.	3620.	3320.	1420.	715.	1075.	1660.	5720.	3280.	
INFLOW	2760.	3190.	6497.	4320.	3173.	3564.	3303.	1692.	1439.	3248.	2566.	3931.	2137.	
REQ DIV	1000.0	1000.0	1000.0	1000.0	1000.0	1000.0	1000.0	1000.0	1000.0	1000.0	1000.0	1000.0	1000.0	
DIVERSN	1000.0	1000.0	1000.0	1000.0	1000.0	1000.0	1000.0	1000.0	1000.0	1000.0	1000.0	1000.0	1000.0	
SHORTGE	0.	0.	0.	0.	0.	0.	0.	0.	0.	0.	0.	0.	0.	
EOP STR	315664	456000	456000	452199	456000	456000	456000	353886	186723	115785	106600	234301	298042	
EOP EL	893.23	929.00	929.00	928.03	929.00	929.00	929.00	902.97	868.15	823.59	819.28	867.99	888.41	
EVAP	0.	0.	0.	0.	0.	0.	0.	2159.	1291.	472.	296.	0.	0.	
REQ PWR	14880.	8698.	13440.	14880.	14400.	14880.	14400.	14880.	14880.	14400.	14880.	14400.	14880.	
SYS 1	191517.	16667.	16667.	16484.	16311.	16098.	15069.	14880.	14880.	14400.	14880.	16729.	16667.	
POWER	268521.	0.	31976.	47792.	27546.	31918.	28343.	28237.	31870.	26339.	12080.	6407.	1013.	
SHORTGE	39540.	14880.	0.	0.	0.	0.	0.	0.	0.	0.	0.	0.	13867.	
SYS SRT	45443.	16667.	403	403	403	403	403	401	401	401	202	403	403	
CASE	403	403	403	403	403	403	403	401	401	401	202	403	403	
LEVEL	6.58	7.00	7.00	6.89	7.00	7.00	7.00	5.16	3.14	2.15	1.00	6.34	6.53	
CSV REL	1594.	0.	1548.	1293.	1324.	1647.	1863.	2318.	3137.	3432.	1710.	785.	100.	
RIV FLW	2053.	0.	2970.	1320.	2213.	2481.	2272.	2318.	3137.	3432.	1710.	785.	100.	
DES FLW	0.	0.	0.	0.	0.	0.	0.	0.	0.	0.	0.	0.	0.	
SHORTGE	0.	0.	0.	0.	0.	0.	0.	0.	0.	0.	0.	0.	0.	

3 RESERVOIR C		LEAKAGE 3 4 0. SERVED BY 3											
		SERVING											
YR 1927	AVG	JAN	FEB	MAR	APR	MAY	JUN	JUL	AUG	SEP	OCT	NOV	DEC
LOC FLW	672.	1145.	1620.	1040.	576.	578.	497.	95.	35.	15.	320.	1410.	820.
UNREG	672.	1145.	1620.	1040.	576.	578.	497.	95.	35.	15.	320.	1410.	820.
INFLW	672.	1145.	1620.	1040.	576.	578.	497.	95.	35.	15.	320.	1410.	820.
EOP STR		125000	125000	124855	125000	125000	75276	31894	22494	25000	105602	124967	
EOP EL		834.00	834.00	833.92	834.00	834.00	802.95	762.30	748.12	752.15	822.71	833.98	
EVAP0	3474.	0.	0.	616.	551.	791.	874.	410.	139.	95.	0.	0.	
CASE		403	403	403	403	403	401	401	401	303	403	403	
LEVEL		7.00	7.00	6.99	7.00	7.00	4.76	2.86	2.33	6.00	6.83	7.00	
CSV REL	254.	100.	100.	100.	100.	246.	324.	889.	734.	171.	100.	55.	100.
RIV FLW	652.	969.	1620.	1040.	568.	567.	484.	889.	734.	171.	278.	55.	505.
DES FLW	100.	100.	100.	100.	100.	100.	100.	100.	100.	100.	100.	100.	100.
SHORTGE	4.	0.	0.	0.	0.	0.	0.	0.	0.	0.	0.	45.	0.

4 CONFLUENCE		LEAKAGE 4 0. SERVED BY 1 2 3											
		LOCAL DIVERSIONS											
YR 1927	AVG	JAN	FEB	MAR	APR	MAY	JUN	JUL	AUG	SEP	OCT	NOV	DEC
LOC FLW	2674.	4585.	6990.	2890.	1969.	2357.	2063.	1043.	379.	647.	1460.	3910.	4145.
UNREG	6630.	10090.	15760.	8250.	5685.	6555.	5880.	2558.	1129.	1737.	3440.	11040.	8245.
INFLW	5379.	5554.	11580.	7250.	4750.	5405.	4819.	4250.	4250.	4250.	3448.	4750.	4750.
REQ DIV	0.	-250.0	-250.0	-250.0	-250.0	-250.0	-250.0	-250.0	-250.0	-250.0	-250.0	-250.0	-250.0
DIVERSN	0.	-250.0	-250.0	-250.0	-250.0	-250.0	-250.0	-250.0	-250.0	-250.0	-250.0	-250.0	-250.0
SHORTGE	0.	0.	0.	0.	0.	0.	0.	0.	0.	0.	0.	0.	0.
RIV FLW	5629.	5804.	11830.	7500.	5000.	5655.	5069.	4500.	4500.	4500.	3698.	5000.	5000.
DES FLW	2101.	100.	100.	100.	2000.	4500.	4500.	4500.	4500.	4500.	100.	100.	100.
SHORTGE	0.	0.	0.	0.	0.	0.	0.	0.	0.	0.	0.	0.	0.
MIN FLW	100.	100.	100.	100.	100.	100.	100.	100.	100.	100.	100.	100.	100.
SHORTGE	0.	0.	0.	0.	0.	0.	0.	0.	0.	0.	0.	0.	0.

SYSTEM 1 POWER SUMMARY

SYSTEM TOTAL		SYSTEM 1 POWER SUMMARY											
REQUIRD	30000.	25000.	25000.	25000.	25000.	25000.	25000.	25000.	25000.	25000.	25000.	25000.	25000.
USABLE	421459.	0.	48776.	55800.	45546.	50518.	46343.	41697.	49363.	44339.	27962.	9489.	1627.
TOTAL	488741.	0.	61496.	70475.	49275.	59797.	54179.	41697.	49363.	63382.	27962.	9489.	1627.
SHORTGE	66684.	25000.	0.	0.	0.	0.	0.	0.	0.	0.	2800.	15511.	23373.

AVERAGES FOR PERIOD OF OPERATION 1926 - 1927

1 RESERVOIR A	2 RESERVOIR B	3 RESERVOIR C	4 CONFLUENCE
LOC FLW 1061.	LOC FLW 1728.	LOC FLW 537.	LOC FLW 2257.
UNREG 1061.	UNREG 2789.	UNREG 537.	UNREG 5583.
INFLOW 1061.	INFLOW 2694.	INFLOW 537.	INFLOW 4303.
EVAP0 4415.	REG DIV 1000.0	EVAP0 2690.	REG DIV .0
REG PWR 87600.	DIVERSN 960.5	DIVERSN .0	DIVERSN .0
SYS 1 111289.	SHORTGE 39.5	CSV REL 209.	SHORTGE .0
POWER 169030.	EVAP0 7053.	RIV FLW 454.	4544.
SHORTGE 21120.	REQ PWR 175200.	DES FLW 100.	2101.
	SYS 1 188711.	SHORTGE 14.	SHORTGE 484.
	POWER 190382.		MIN FLW 100.
	SHORTGE 59539.		SHORTGE 0.
CSV REL 775.	CSV REL 1362.		
RIV FLW 966.	RIV FLW 1592.		
DES FLW 0.	DES FLW 0.		
SHORTGE 0.	SHORTGE 0.		

DIVERSION SHORTAGE INDEX 2 .312 4 -1.000

POWER SHORTAGE INDEX 1 5.910 2 12.852
 POWER SYSTEM 1 SHORTAGE INDEX 11.238 NO. OF SHORTAGES 11 MAX. SHORTAGE = 25000.

WATER SHORTAGE INDEX 1 -1.000 2 -1.000 3 2.943 4 10.598

MIN FLOW SHORTAGE INDEX 1 -1.000 2 -1.000 3 -1.000 4 .000

DES FLOW SHORTAGES	REQ FLOW SHORTAGES	SYS PWR SHORTAGES	AT SITE PWR SHRTGE
STA NO	NO	NO	NO
MAX	MAX	MAX	MAX
1 0	0	10 11136.	9 7440.
2 0	0	11 16667.	11 14880.
3 5 100.	0	0	0
4 3 3927.	0	0	0

STORAGE FREQUENCY PER 2 YEARS AT LOCATION 1

CONS POOL	JAN	FEB	MAR	APR	MAY	JUN	JUL	AUG	SEP	OCT	NOV	DEC
95-100 PCT	1	2	2	1	1	1	1	0	0	0	2	2
90- 95 PCT	0	0	0	0	0	0	0	0	0	0	0	0
80- 90 PCT	0	0	0	1	0	0	0	1	0	0	0	0
70- 80 PCT	0	0	0	0	0	0	0	0	0	0	0	0
60- 70 PCT	1	0	0	0	1	0	0	0	0	0	0	0
40- 60 PCT	0	0	0	0	0	0	0	0	0	0	0	0
20- 40 PCT	0	0	0	0	0	0	0	0	1	0	0	0
-0- 20 PCT	0	0	0	0	0	1	1	1	1	2	0	0

TECHNICAL PAPER SERIES

1. Use of Interrelated Records to Simulate Streamflow, Leo R. Beard
December 1964
2. Optimization Techniques for Hydrologic Engineering, Leo R. Beard
April 1966
3. Methods for Determination of Safe Yield and Compensation Water from
Storage Reservoirs, Leo R. Beard, August 1965
4. Functional Evaluation of a Water Resources System, Leo R. Beard
January 1967
5. Streamflow Synthesis for Ungaged Rivers, Leo R. Beard, October 1967
6. Simulation of Daily Streamflow, Leo R. Beard, April 1968
7. Pilot Study for Storage Requirements for Low Flow Augmentation,
A. J. Fredrich, April 1968
8. Worth of Streamflow Data for Project Design - A Pilot Study,
D. R. Dawdy, H.E. Kubik, L.R. Beard, and E.R. Close, April 1968
9. Economic Evaluation of Reservoir System Accomplishments, Leo R. Beard
May 1968
10. Hydrologic Simulation in Water-Yield Analysis, Leo R. Beard, 1964
11. Survey of Programs for Water Surface Profiles, Bill S. Eichert
August 1968
12. Hypothetical Flood Computation for a Stream System, Leo R. Beard
April 1968
13. Maximum Utilization of Scarce Data in Hydrologic Design, Leo R. Beard
and A. J. Fredrich, March 1969
14. Techniques for Evaluating Long-Term Reservoir Yields, A. J. Fredrich
February 1969
15. Hydrostatistics - Principles of Application, Leo R. Beard
December 1969
16. A Hydrologic Water Resource System Modeling Technique, L.G. Hulman
1969
17. Hydrologic Engineering Techniques for Regional Water Resources Planning,
A. J. Fredrich and E. F. Hawkins, October 1969
18. Estimating Monthly Streamflows Within a Region, Leo R. Beard, E.F.Hawkins
and A. J. Fredrich, January 1970
19. Suspended Sediment Discharge in Streams, Charles E. Abraham, April 1969
20. Computer Determination of Flow Through Bridges, Bill S. Eichert and
John Peters, December 1970

TECHNICAL PAPER SERIES (Cont.)

21. An Approach to Reservoir Temperature Analysis, Leo R. Beard and R. G. Willey, April 1970
22. A Finite Difference Method for Analyzing Liquid Flow in Variably Saturated Porous Media, Richard L. Cooley, April 1970
23. Uses of Simulation in River Basin Planning, William K. Johnson and E. T. McGee, August 1970
24. Hydroelectric Power Analysis in Reservoir Systems, A. J. Fredrich August 1970
25. Status of Water Resource Systems Analysis, Leo R. Beard January 1971
26. System Relationships for Panama Canal Water Supply, Lewis G. Hulman April 1971
27. Systems Analysis of the Panama Canal Water Supply, David C. Lewis and Leo R. Beard, April 1971
28. Digital Simulation of an Existing Water Resources System, A. J. Fredrich, October 1971
29. Computer Applications in Continuing Education, A. J. Fredrich, Bill S. Eichert, and Darryl W. Davis, January 1972
30. Drought Severity and Water Supply Dependability, Leo R. Beard and Harold E. Kubik, January 1972
31. Development of System Operation Rules for an Existing System by Simulation, C. Pat Davis and Augustine J. Fredrich, October 1971
32. Alternative Approaches to Water Resource System Simulation, Leo R. Beard, Arden Weiss, and T. Al Austin, May 1972
33. System Simulation for Integrated Use of Hydroelectric and Thermal Power Generation, Augustine J. Fredrich and Leo R. Beard, October 1972
34. Optimizing Flood Control Allocation for a Multipurpose Reservoir, Fred K. Duren and Leo R. Beard, August 1972
35. Computer Models for Rainfall-Runoff and River Hydraulic Analysis, Darryl W. Davis, March 1973
36. Evaluation of Drought Effects at Lake Atitlan, Arlen D. Feldman
37. Downstream Effects of the Levee Overtopping at Wilkes-Barre, Pa., During Tropical Storm Agnes, Arlen D. Feldman, April 1973

**LATE
LME**