

AD-A104 919

HYDROLOGIC ENGINEERING CENTER DAVIS CA
DEVELOPMENT OF SYSTEM OPERATION RULES FOR AN EXISTING SYSTEM BY--ETC(U)
AUG 71 C P DAVIS, A J FREDRICH
HEC-TP-31

F/6 13/2

UNCLASSIFIED

ML

[1 of 1]
AD-A104 919



END
DATE
FILMED
10-81
DTIC

13

AUGUST 1971
TECHNICAL PAPER NO. 31

AD A104919

DEVELOPMENT OF SYSTEM OPERATION
RULES FOR AN EXISTING SYSTEM
BY SIMULATION

by
C. PAT DAVIS
AUGUSTINE J. FREDRICH

DTIC
ELECTE
S OCT 2 1981 D

DTIC FILE COPY

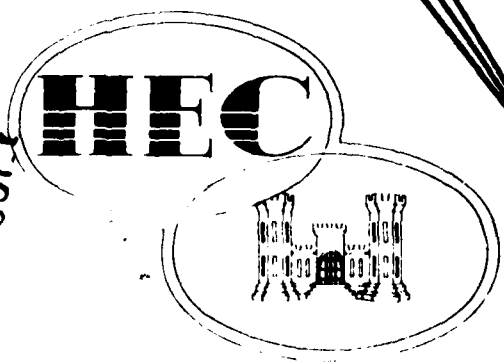

CORPS OF ENGINEERS
U. S. ARMY

THE HYDROLOGIC
ENGINEERING CENTER

- research
- training
- application

Approved for publication by
the Institute of Electrical and Electronics Engineers, Inc.

Papers in this series have resulted from technical activities of The Hydrologic Engineering Center. Versions of some of these have been published in technical journals or in conference proceedings. The purpose of this series is to make the information available for use in the Center's training program and for distribution within the Corps of Engineers.

UNCLASSIFIED

SECURITY CLASSIFICATION OF THIS PAGE (When Data Entered)

9 REPORT DOCUMENTATION PAGE		READ INSTRUCTIONS BEFORE COMPLETING FORM
1. REPORT NUMBER	2. GOVT ACCESSION NO.	3. RECIPIENT'S CATALOG NUMBER
Technical Paper No. 31	AD A104919	
4. TITLE (and Subtitle)		5. TYPE OF REPORT & PERIOD COVERED
DEVELOPMENT OF SYSTEM OPERATION RULES FOR AN EXISTING SYSTEM BY SIMULATION		
6. PERFORMING ORG. REPORT NUMBER		
7. AUTHOR(s)		8. CONTRACT OR GRANT NUMBER(s)
C. Pat/Davis and Augustine J./Fredrich		
9. PERFORMING ORGANIZATION NAME AND ADDRESS		10. PROGRAM ELEMENT, PROJECT, TASK AREA & WORK UNIT NUMBERS
U.S. Army Corps of Engineers The Hydrologic Engineering Center 609 Second Street, Davis, CA 95616		
11. CONTROLLING OFFICE NAME AND ADDRESS		12. REPORT DATE
		August 1971
		13. NUMBER OF PAGES
		20
14. MONITORING AGENCY NAME & ADDRESS (if different from Controlling Office)		15. SECURITY CLASS. (of this report)
(14) HEC-TR-31		Unclassified
		15a. DECLASSIFICATION/DOWNGRADING SCHEDULE
16. DISTRIBUTION STATEMENT (of this Report)		
Distribution of this publication is unlimited.		
17. DISTRIBUTION STATEMENT (of the abstract entered in Block 20, if different from Report)		
18. SUPPLEMENTARY NOTES		
Presented at the ASCE Hydraulics Specialty Conference, August 1971.		
19. KEY WORDS (Continue on reverse side if necessary and identify by block number)		
Systems analysis, Reservoir operation, Simulation, Reservoirs, Systems engineering, Models, Computer models, Regulation, Reservoir stages.		
20. ABSTRACT (Continue on reverse side if necessary and identify by block number)		
Current operation rules for existing reservoir systems have evolved from combinations of operation rules developed for component reservoirs as single units. Consequently, the rules frequently do not permit full realization of the benefits of coordinated system operation. A simulation model has been developed to study a large existing water resource system on the Arkansas, White, and Red Rivers. The system was not previously amenable to comprehensive analysis. A program developed by the Hydrologic Engineering Center, Corps of Engineers, Davis, (Continued)		

DD FORM 1473 1 JAN 73

EDITION OF 1 NOV 65 IS OBSOLETE

401964

SECURITY CLASSIFICATION OF THIS PAGE (When Data Entered)

81 10 2 012

20 (Continued)

California, was selected for the system study because it appeared to have the capability to consider most of the factors needed for developing operating rules for the system. Basically, the program enables the computer to perform a simulation study that in principle is no different from the routine studies performed in the past; the degree of refinement and complexity, and the speed of computations have been changed. Three simulation studies of alternative operation plans for the system have been completed. Preliminary guide curves have been developed from these simulations and additional regulation guides will be developed soon. Future studies are discussed.



Accession For	
NTIS GRA&I	<input checked="" type="checkbox"/>
DTIC TAB	<input type="checkbox"/>
Unannounced	<input type="checkbox"/>
Justification	
By _____	
Distribution/	
Availability Codes	
Dist	Avail and/or Special
A	

DEVELOPMENT OF SYSTEM OPERATION
RULES FOR AN EXISTING SYSTEM
BY SIMULATION⁽¹⁾

by

C. Pat Davis⁽²⁾ and Augustine J. Fredrich⁽³⁾

INTRODUCTION

Current operation rules for existing reservoir systems have, in many cases, evolved from combinations of operation rules developed for the component reservoirs operating as single units. Consequently, the rules frequently do not explicitly reflect all of the important system operation considerations and, more importantly, do not permit full realization of the benefits of coordinated system operation. Furthermore, in many cases the single-project operation rules are relatively old and do not adequately account for changes in operation objectives that are occurring quite frequently as a result of the ever-expanding interest in and concern for comprehensive evaluation of the impact of water resources developments. All of these factors have accentuated the need for development of system operation rules that are based on comprehensive evaluation of the system as a whole.

Early developments in the use of systems analysis techniques in the field of water resources focused on the planning and design of such systems-- concentrating on determining the number, size and location of components within the system to meet certain functional objectives. These analyses,

(1) For presentation at the ASCE Hydraulics Specialty Conference, August 1971

(2) Hydraulic Engineer, Reservoir Control Center, Southwestern Division, U.S. Army Corps of Engineers, Dallas, Texas

(3) Chief, Research Branch, The Hydrologic Engineering Center, U.S. Army Corps of Engineers, Davis, California

by and large, used simplistic operation rules that were prespecified independent of system configuration and were invariant from alternative to alternative. Thus, the effect was to ignore system operation policy as a planning or design variable. This tendency to ignore operation policy is understandable because including operation policy adds a large number of variables to the basic problem formulation for a complex system, and frequently data and information are not available for inclusion in the analysis during the planning and design phases. Nevertheless, the system operation rules become an important factor as soon as a significant number of components in a system are completed, and it was not long before researchers became interested in systems analyses which included system operation policy as a variable.

Although many techniques for developing optimal operating plans for water resources systems have been described in the technical literature during the past few years, it is doubtful that any of the techniques would be completely satisfactory for use in evaluating system operation plans for a large, complex existing system. In addition to the problems caused by the necessity for simplification, linearization, and generalization to make the existing system mathematically tractable, there are gross inequities in the reckoning of the worth of the output for some of the authorized and approved purposes. These inequities result from political, legal, institutional and social considerations, and their effect in an optimization process would likely be the production of a politically or institutionally infeasible operation plan. In order to avoid the problems

inherent in attempting to quantify and handle explicitly some of these constraints, simulation of system operation has been attempted with the idea that a satisfactory operation plan might be developed through successive incremental improvements in operation policy.

By postulating an operation plan, operating the simulation model to determine the results of the proposed plan, evaluating the results in terms of the desired operation objectives, making modifications to the proposed operation plan to rectify any errors or inconsistencies in the policy as indicated by the results of the simulation study, and repeating the process until the desired objectives are realized, an operation plan can be developed to satisfy any feasible operation objectives. The probability that an optimal or near-optimal plan can be developed through successive incrementally improved simulations is dependent on three factors: the ability of the engineer or engineers conducting the study to perceive and formulate operation objectives that accurately reflect all of the requirements and services that must be satisfied by the system; the ability of the engineer or engineers conducting the study to evaluate the results of the simulation studies and formulate improved operation rules that would produce the desired results; and, the degree of fidelity with which the simulation model being used reproduces physical occurrences in the prototype system. This paper describes some of the efforts expended thus far with respect to perception and formulation of operation objectives and evaluation of study results.

USE OF SIMULATION

Simulation may be described as the process of duplicating the essence of a system or activity with respect to some predetermined objective without actually attaining reality itself. This description implies that it is not necessary to duplicate all facets of a system in a simulation study, but rather that the study should only duplicate those facets which are essential to understanding the system's behavior with respect to the study objectives. Thus, in a study of system operation it is unlikely that detailed modeling of the structural components would be necessary, just as it is unlikely that detailed modeling of water quality parameters would be required in simulating the structural behavior of a project. Consequently, it is important to define as precisely as possible the scope of the simulation study and the study objectives.

The use of simulation as a tool in studying the operation of reservoir projects is not new. For at least 20 years various simulation studies using hand-crafted simulation models (i.e., manual routing studies) have been conducted to evaluate the operation of individual projects and system of projects. What is new, however, is the scope and complexity of the present simulation studies. Historically, studies have been limited in both scope and objective. For example, the White River Basin projects, which will be described, have been studied as a system with respect to potential for power production during adverse streamflow conditions. The limitations here are fairly obvious: only the White River projects, primarily with respect to hydropower production, and only for adverse streamflow conditions. The reasons for the limitations are typical and valid but

perhaps not so obvious. First, the availability of computer hardware and usable simulation models has not been conducive to pursuit of a study with comprehensive scope of objectives. Next, data have not always been available to permit consideration of all important facets. Also, the concern and interest of the engineering personnel and society as a whole did not encourage study of all facets that are now important. And finally, manpower and budget constraints have, in effect, limited the scope of past studies.

During the past few years, events have occurred that have increased the feasibility of comprehensive studies of water resources systems. Each of the constraints listed in the previous paragraph has been relaxed somewhat in recent years, and it is now possible to think in terms of a study which will permit consideration of all completed and authorized projects operating for all authorized and approved purposes. Although it is impossible to fully consider all purposes at the present time (primarily because of a lack of data and information necessary to define the impact of operation decisions on some purposes), it appears that the capability exists to study many facets of multiple-purpose operation that are vitally important, but which have not been studied in the past. Consequently, operation rules can be developed and implemented to coordinate operation of projects in the system for all authorized and approved purposes. In fact, it appears that the capability exists to develop operation rules that would result in significant improvements in the system operation, but which might not be amenable to implementation because of a lack of institutional arrangements between Federal, state and private ownerships in the Basin.

DESCRIPTION OF SYSTEM

The particular study described here is of a system of reservoirs located on the Arkansas, White and Red Rivers in Arkansas, Missouri, Oklahoma, New Mexico, Kansas and Texas. The objective of this study is to improve regulation guides for an existing system of reservoirs, each regulated for two or more of seven different purposes. It is an existing system composed of 19 reservoirs located in the three river basins which are hydraulically independent. There are 15 hydroelectric power projects and these projects are interconnected in a way which results in three distinct systems: a non-Federal system composed of two projects, a Federal system composed of two projects and a second Federal system composed of ten projects. There is also an isolated non-Federal project intermingled in the Federal system.

The Arkansas, White and Red Rivers and their tributaries drain approximately one-eleventh of the nation's conterminous land area. The A-W-R area considered in these studies is within the Southwestern Division, and consists of about 233,000 square miles, with the Arkansas River draining 159,000 square miles; the White River draining 22,000 square miles and the Red River draining 52,000 square miles. The principal surface features of the A-W-R Basins are a relatively small extent of high mountains in the west, a large area of low mountains which rise abruptly from the Coastal and Mississippi Alluvial Plains in the east and a broad expanse of interior lowland.

The average annual runoff varies from 25 inches in southeast Arkansas to almost zero in the western part of the basin. The eastern half of the basin area contributes 95 percent of the average annual runoff. The period

of high runoff starts in the winter and early spring in the southeast area and moves northwestward rather uniformly in time to late spring and summer in the western part of the basins.

There are wide differences in the character of flood control releases for the different basins. In the White River projects for example, the power releases alone could, under some conditions, cause flooding, while in the Arkansas basin the power releases are small in comparison to flows which cause flooding. Consequently, in the White River basin a large portion of the total release is made through the turbines; but in the Arkansas River basin a relatively large proportion of the total release is made through spillways.

There are presently 19 projects included in this study. Ultimately 25 projects--22 Corps projects and three non-Federal projects--will be included (plate 1). Six of the Corps projects will be completed between now and 1973. Of the 16 Corps projects now in operation, there are 12 hydroelectric plants with a total of 1351 megawatts of installed capacity. There will be four additional hydropower projects added between now and 1973, bringing the total installed capacity to 1652 megawatts. All of the additional hydropower projects are in the Arkansas basin. When completed there will be two projects with a total of 170 megawatts installed capacity in the Red River basin, nine projects with a total of 664 megawatts of installed capacity in the Arkansas River basin and five projects with a total of 818 megawatts of installed capacity in the White River basin. Two of the non-Federal projects with a total of 187 megawatts of installed capacity are in the Arkansas basin and one project with 16 megawatts of installed capacity is located in the White basin. The minimum-year energy available

from the Corps system is approximately 1700 gigawatt (1000 megawatts) hours-- an annual plant factor of about 12 percent. The average annual energy is about 5,000 gigawatt hours or 34 percent plant factor. These values were derived from previous studies and will probably change as a result of the study described herein. The energy demand on the system is about 4000 gigawatt hours or 80 percent of the average annual hydroelectric energy production. This load is met by supplementing hydroelectric generation with purchases of thermal energy in less-than-average-runoff years. In fact, it may be necessary to purchase thermal energy in some average-runoff years if the inflow is not well distributed, since the projects cannot "carry" the load under adverse flow conditions for more than a month or two without jeopardizing their capability for peaking operation if adverse flow conditions persist during peak load seasons.

Plate 2 shows a schematic of the system and plate 3 shows some pertinent data for the projects. The usable conservation storage in the projects ranges from 19000 acre-feet of regulating pondage of some of the small "run-of-river" projects to a million and a half acre-feet in some of the large storage projects. Power heads range from less than 30 feet for some of the Arkansas River navigation projects to more than 200 feet for the White River projects. This system is complicated not only because it consists of three basins but also because at present there are two power systems. The hydroelectric energy produced at Table Rock and Bull Shoals in the White River basin goes to one system while the energy produced at the other Federal projects is marketed in another region with a significantly different seasonal distribution of energy and capacity requirements.

THE SIMULATION MODEL

A program developed by The Hydrologic Engineering Center (HEC) was selected for the system study because it appeared to have the capability to consider most of the factors that appear to be important for development of operation rules for the A-W-R system. Several computer simulations of the system were made to: (1) test the validity of the program for use in studying the A-W-R system; (2) educate study participants in the techniques of computer simulation models and familiarize participants with the capabilities of the specific program; and, (3) provide the opportunity to modify and improve the program to fit the specific conditions of the existing A-W-R system. These simulations demonstrated that the HEC program was suitable for simulation of most important conservation purposes in the A-W-R system.

A review of the initial computer simulation of the A-W-R system indicated that the program would be most useful in comparing alternative operation plans when the most important factors affecting the various plans could be considered, either explicitly or implicitly, through criteria and data for a monthly routing interval. In the opinion of a majority of the study participants, the operation requirements for purposes such as flood control, water quality enhancement and peaking power operation, which usually require detailed short-period analysis to accurately define their effect, were either relatively unimportant with respect to the overall system operation plan or were adequately simulated for comparative purposes in the monthly routing interval. After the program was adopted for use in the A-W-R system studies, it was decided that

several system simulations or runs would be made to attempt to identify the nature of a feasible system operation plan and to determine, insofar as possible, the characteristics of the specific operation procedures that would constitute the plan. Basically the program enables the computer to perform a simulation study that, in principle, is no different than the hundreds of routing studies that have been performed in the past. Only the degree of refinement, speed of computation, and degree of complexity have been changed. In the computer simulation model (program) it is possible to consider many more factors than could be considered in traditional routing studies, to consider each factor in much more detail than it has been previously considered, and to study a much larger system than could previously have been studied.

RESULTS

Three different regulation plans were studied through the use of the system simulation model. System guide curves which related operation decisions to system state (as measured by usable conservation storage remaining) were used to effect operation objectives. Three guide curves--upper, middle, and lower--were used in the three plans. The upper guide curve was set at the top of the conservation pool for each project. The lower guide curve was set so that the conservation storage would be just exhausted during the most critical drought of record assuming that the full capability for purchasing thermal energy would be used at all times the pool levels were below the lower guide curve. Establishing the location of this curve required numerous successive approximations. The middle guide curve was arbitrarily defined as being half-way between the upper and lower guide curves.

The first operation plan studied used only the lower guide curve. The operation was based on meeting the system power demands from hydroelectric generation alone when the reservoirs were between the top of the conservation pool and the lower guide curve and upon meeting the system load from maximum thermal energy purchases and minimum hydroelectric generation when the reservoirs were below the lower guide curve. The second operation plan studied used only the upper guide curve. In this plan thermal energy purchases would be made anytime the reservoirs were below the upper guide curve (top of conservation pool). In this plan the system power demand would be met by hydroelectric generation alone only when the reservoirs were at or above the upper guide curve. The third operation plan used the middle and lower guide curves. When the reservoirs were above the middle guide curve the system power demand was met by hydroelectric generation alone. When the reservoirs were between the middle and lower guide curves the system power demands were met by a combination of hydroelectric generation and partial purchases of thermal energy, and when the reservoirs were below the lower guide curve the system power demands were met by maximum thermal energy purchases and minimum hydroelectric generation.

The upper guide curve plan and lower guide curve plan were used to define extreme conditons that could be used as standards for comparison with subsequent analyses. The upper guide curve plan generally favors recreation interests because it maintains the reservoir pools at relatively high levels and tends to minimize fluctuations in the reservoir surface elevation. However, relatively large purchases of thermal energy are necessary in this type of an operation scheme.

The lower guide curve plan produces generally lower reservoir elevations and tends to maximize the production of hydroelectric energy. The operation plan which uses the middle and lower guide curves represents a first attempt to establish an implementable operation plan. It provides an insight into the system's sensitivity to changes in operation plan, establishes a starting point for future studies, and identifies parameter and conditions that must be given more attention in developing future operation plans.

In analyzing the power function of the system, the Corps of Engineers and the Southwestern Power Administration (SPA) reviewed the periods of high, average and low energy generation and the relation of the generation to the expected load shape for the period. The Corps performed detailed load-resource analyses for a few selected periods, and SPA used an available analysis load-resource computer program to analyze the entire period of record on a month-by-month basis.

Although the recreation function shares the joint cost in only two projects, the large lake areas involved make recreation a major project purpose. There is no doubt that recreation will become even more important in the future of these and other projects; therefore, considerable effort was applied in these simulation studies to determine the effects of alternative operation plans on this purpose. In analyzing power generation, system indicators were used to compare and evaluate alternative regulation schemes. Recreation, however, is primarily evaluated on a project-to-project basis, although there is undoubtedly a need for some degree of drawdown balance between projects which implies that some system operation parameters would have to reflect recreation considerations. Various statistical parameters

were developed for use as recreation indicators. These included, for the peak recreation months of May through September, the average lake elevations, the standard deviation about the average, and the average difference between successive monthly pool elevations.

In addition to power and recreation other purposes such as flood control, water supply, water quality, and fish and wildlife were considered in the studies. Generally the existing constraints and regulations for these purposes were adhered to and no attempt was made to change the regulation for them.

FUTURE WORK

Since the purpose of this study is to develop and evaluate regulation guides and rules for the existing projects, it is anticipated that the study--modified as necessary to reflect changes in operation priorities and criteria--will continue throughout the life of the projects. Changes are occurring continuously in a system of this size and the need for an analytical tool for evaluation of major changes in operation objectives is obvious. Future studies will include analyses of effects of changes in quantity and schedule of releases for water supply and fish and wildlife enhancement, use of seasonal flood control storage, and effects of contractual changes that would alter the system power demand. These types of analyses are essential if the operation of the system is to remain responsive to the rapidly changing water needs and uses of the populace.

In the immediate future a report will be prepared to describe in detail the work that has been accomplished thus far and to discuss the analyses of the three simulation studies completed to date. The criteria for the

study will be reviewed and updated before additional studies are undertaken to insure that the model reflects the current state of the system and the individual components.

SUMMARY

A simulation model has been developed to study a large existing water resource system which was not previously amenable to comprehensive analysis. Three simulation studies of alternative operation plans for the system have been completed.

Preliminary guide curves have been developed from these simulations and additional regulation guides will be developed in the near future. Experience has been gained with the model so that additional simulations and analyses can be made more readily. There have been some shortcomings in the simulation model, however, most of the problems and delays have been because of the age-old problem of communications. As the problems grow larger and involve more people with different objectives, the need for considering many persons' points of view will become increasingly important in a system study of this type.

ACKNOWLEDGMENTS

Many persons in the Corps of Engineers and the Southwestern Power Administration have been involved in this study. Some of those persons which have most actively participated are Mr. Leo R. Beard, Director of The Hydrologic Engineering Center, who developed the simulation model described herein, and has lent his support and suggestions for its use in this study;

Messrs. David C. Lewis and William K. Johnson of the HEC staff; Mr. William S. Swanson of the Southwestern Division, Mr. Gerald E. Thomas of the Little Rock District; and Mr. James Dalton formerly of the Little Rock District and now of the Southwestern Division office of the Corps. Messrs. Walt Bowers and Kendall Kerr of the Southwestern Power Administration have been invaluable in furnishing and explaining load data used in the study.

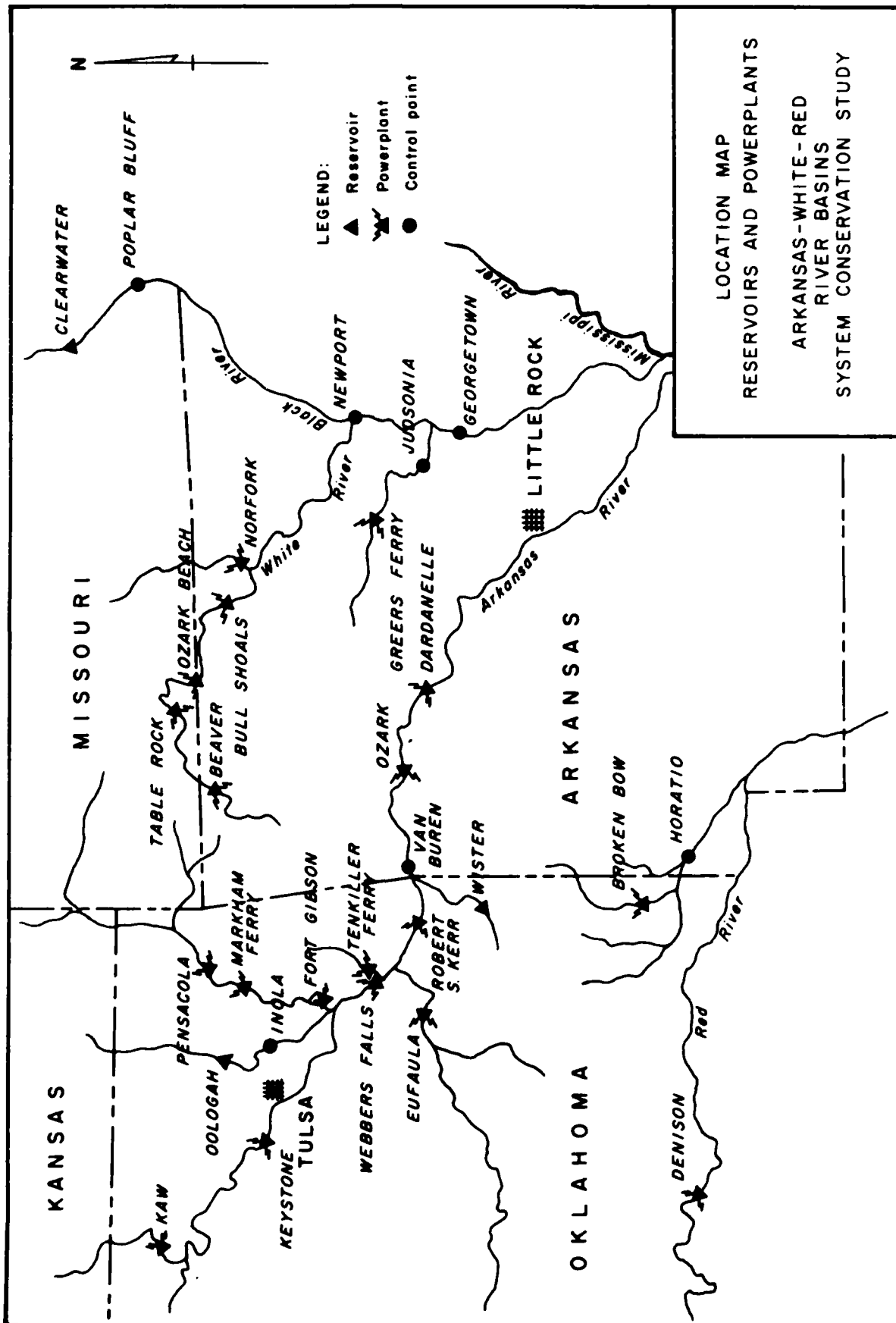

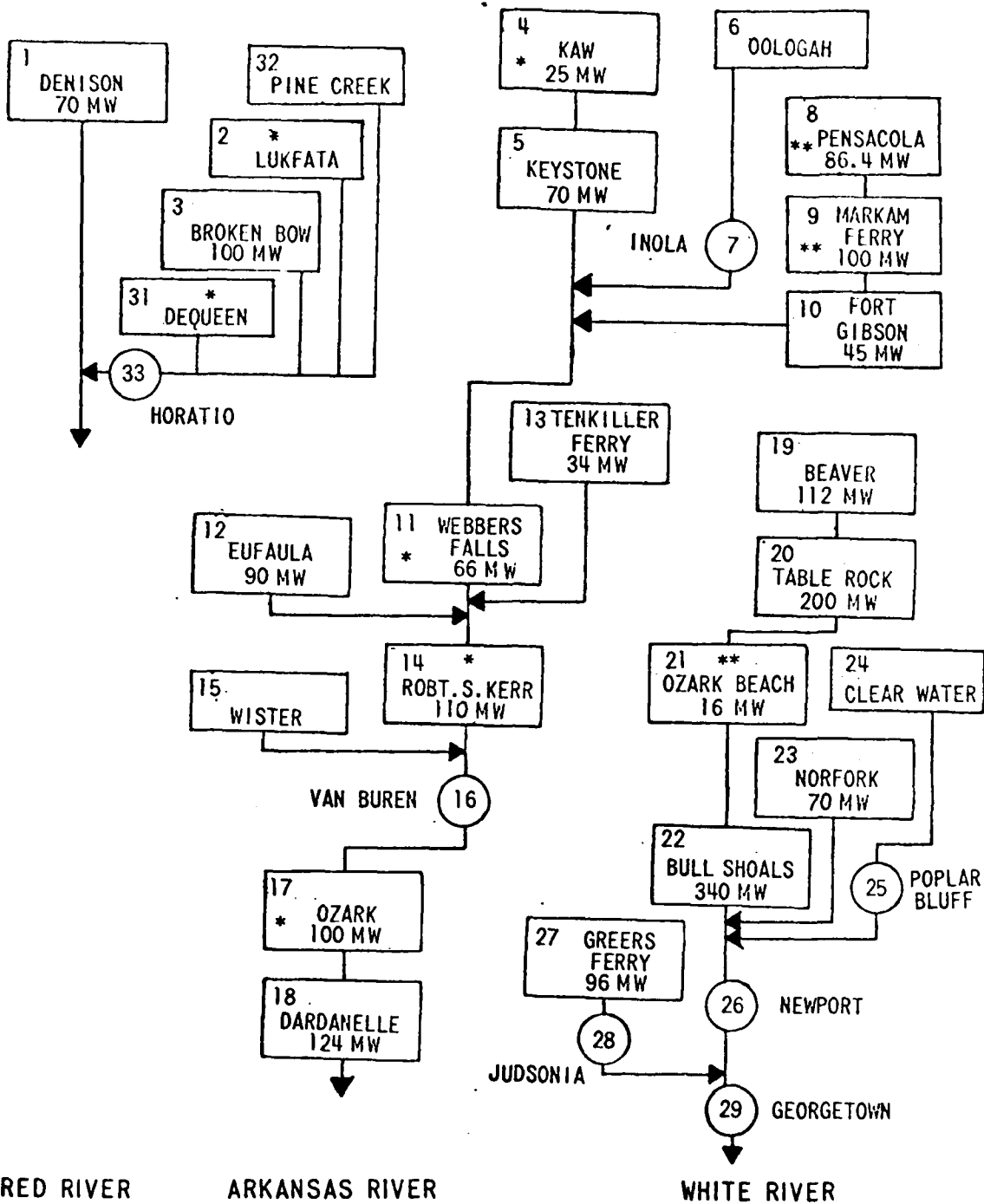

RED RIVER

ARKANSAS RIVER

WHITE RIVER

- * NOT IN OPERATION
- ** NON-FEDERAL
- CONTROL POINT

ARKANSAS-WHITE-RED RIVERS
SCHEMATIC STREAMFLOW DIAGRAM
HYDRO POWER SYSTEM

Pertinent Data Summary
 ARKANSAS-WHITE-RED RIVERS
 Reservoir System Conservation Studies

PROJECT	POOL ELEVATIONS, ft., msl.		STORAGE CAPACITY		Installed Capacity Megawatts	Design Head, Ft.	Date Placed in Operation(1)
	Top of F/C Pool	Top of Cons. Pool	Bottom Cons. Pool	1000 Ac.Ft. Flood Cons.			
WHITE RIVER							
Beaver	1,130	1,120	1,075 (3)	299.6	112	164	1963
Table Rock	931	915	884 (3)	760.0	200	190	1956
Ozark Beach (2)	None	701.1	694.1	None	16	Unknown	1913
Bull Shoals	695	654	630 (3)	2,360.0	340	190	1950
Norfolk	580	552	528.5(3)	731.8	70	160	1943
Clearwater	567	494	N.A.	391.78	N.A.	N.A.	1947
Greers Ferry	487	461	433 (3)	934.0	96	175	1961
ARKANSAS RIVER							
Kaw							
Keystone	1,044.5	1,013.0	996.0	866.0	25.0	86(4)	1974
Oologah	754.0	723.0	706.0	1,216.0	70.0	74(4)	1964
Pensacola(2)	661.0	638.0	592.0	965.6	N.A.	N.A.	1963
Markham Ferry(2)	755.0	745.0	705.0	525.0	86.4	105(4)	1940
Fort Gibson	636.0	619.0	N.A.	244.2	100.0	43(4)	1963
Webbers Falls	582.0	554.0	551.0	919.2	45.0	51(4)	1949
Tenkiller Ferry	N.A.	490.0	487.0	None	66.0	21(4)	1970
Eufaula	667.0	631.0	594.5	588.6	34.0	114(4)	1952
R. S. Kerr	597.0	585.0	565.0	1,470.0	90.0	84(4)	1964
Wister	N.A.	460.0	458.0	None	110.0	26(4)	1970
Ozark	502.5	471.6	466.0	400.0	N.A.	N.A.	1949
Dardanelle	372	None	370	None	100	32	1969
	338	None	336	None	124	48	1964
RED RIVER							
Denison	640.0	617.25	590.0	2,637.5	70.0	91(4)	1943
Pine Creek	480.0	443.5	414.0	388.1	N.A.	N.A.	1969
Lukfata	589.0	528.0	479.5	171.1	N.A.	N.A.	1977
Broken Bow	627.5	599.5	559.0	449.8	100.0	165(4)	1968
DeQueen	473.5	437.0	415.0	101.2	N.A.	N.A.	1973

- (1) Date project was available for operation. Corresponds to beginning of post-project conditions.
 (2) Non-Federal project.
 (3) Rated Pool.
 (4) Rated Head.

TECHNICAL PAPER SERIES

1. Use of Interrelated Records to Simulate Streamflow (1965), Leo R. Beard
2. Optimization Techniques for Hydrologic Engineering (1966), Leo R. Beard
3. Methods for Determination of Safe Yield and Compensation Water from Storage Reservoirs (1966), Leo R. Beard
4. Functional Evaluation of a Water Resources System (1967), Leo R. Beard
5. Streamflow Synthesis for Ungaged Rivers (1967), Leo R. Beard
6. Simulation of Daily Streamflow (1967), Leo R. Beard
7. Pilot Study for Storage Requirements for Low Flow Augmentation (1968), A. J. Fredrich
8. Worth of Streamflow Data for Project Design - A Pilot Study (1968), D. R. Dawdy, H. E. Kubik, L. R. Beard, and E. R. Close
9. Economic Evaluation of Reservoir System Accomplishments (1968), Leo R. Beard
10. Hydrologic Simulation in Water-Yield Analysis (1964), Leo R. Beard
11. Survey of Programs for Water Surface Profiles (1968), Bill S. Eichert
12. Hypothetical Flood Computation for a Stream System (1968), Leo R. Beard
13. Maximum Utilization of Scarce Data in Hydrologic Design (1969), Leo R. Beard and A. J. Fredrich
14. Techniques for Evaluating Long-Term Reservoir Yields (1969), A. J. Fredrich
15. Hydrostatistics - Principles of Application (1969), Leo R. Beard
16. A Hydrologic Water Resource System Modeling Technique (1969), L. G. Hulman
17. Hydrologic Engineering Techniques for Regional Water Resources Planning (1969), A. J. Fredrich and E. F. Hawkins
18. Estimating Monthly Streamflows Within a Region (1970), Leo R. Beard, Augustine J. Fredrich, and Edward F. Hawkins
19. Suspended Sediment Discharge in Streams (1969), Charles E. Abraham
20. Computer Determination of Flow Through Bridges (1970), Bill Eichert and John Peters
21. An Approach to Reservoir Temperature Analysis (1970), Leo R. Beard and R. G. Willey
22. A Finite Difference Method for Analyzing Liquid Flow in Variably Saturated Porous Media (1970), Richard L. Cooley
23. Uses of Simulation in River Basin Planning (1970), William K. Johnson and E. T. McGee
24. Hydroelectric Power Analysis in Reservoir Systems (1970), Augustine J. Fredrich
25. Status of Water Resource Systems Analysis (1971), Leo R. Beard
26. System Relationships for Panama Canal Water Supply Study (1971), Lewis G. Hulman
27. Systems Analysis of the Panama Canal Water Supply (1971), David C. Lewis and Leo R. Beard
28. Digital Simulation of an Existing Water Resources System (1971), Augustine J. Fredrich
29. Computer Applications in Continuing Education (1972), Augustine J. Fredrich, Bill S. Eichert, and Darryl W. Davis
30. Drought Severity and Water Supply Dependability (1972), Leo R. Beard and Harold E. Kubik

DATE
FILMED
-8