

AD-A104 953

PRC CONSOER TOWNSEND INC ST LOUIS MO  
NATIONAL DAM SAFETY PROGRAM. SMITH LAKE DAM (MO 11124), MISSISS--ETC(U)  
DEC 80 W G SHIFRIN DACW43-80-C-0094

F/6 13/13

UNCLASSIFIED

NL

1 OF 1  
AD A  
10-4-9-83

END  
DATE  
FILMED  
10-81  
DTIC

LEVEL

12

MISSISSIPPI-SALT-QUINCY RIVER BASIN

AD A104953

SMITH LAKE DAM  
PIKE COUNTY, MISSOURI  
MO. III24

DTIC  
ELECTRONIC  
OCT 6 1981  
H

PHASE I INSPECTION REPORT  
NATIONAL DAM SAFETY PROGRAM



United States Army  
Corps of Engineers  
... Serving the Army  
... Serving the Nation

St. Louis District

DISTRIBUTION STATEMENT A  
Approved for public release;  
Distribution Unlimited

DTIC FILE COPY

PREPARED BY: U. S. ARMY ENGINEER DISTRICT, ST. LOUIS

FOR: STATE OF MISSOURI

"Original contains color  
plates: All text and  
illustrations will be in black and  
white"

DECEMBER 1980

81 10 2 147

UNCLASSIFIED

SECURITY CLASSIFICATION OF THIS PAGE (When Data Entered)

REPORT DOCUMENTATION PAGE		READ INSTRUCTIONS BEFORE COMPLETING FORM	
1. REPORT NUMBER	2. GOVT ACCESSION NO.	3. RECIPIENT'S CATALOG NUMBER	
	10-A304953		
4. TITLE (and Subtitle) Phase I Dam Inspection Report National Dam Safety Program Smith Lake Dam (MO 11124) Pike County, Missouri		5. TYPE OF REPORT & PERIOD COVERED 7 Final Report.	
7. AUTHOR(s) Consoer, Townsend and Associates, Ltd.		6. PERFORMING ORG. REPORT NUMBER	
		8. CONTRACT OR GRANT NUMBER(s) 15 DACW43-80-C-0094	
9. PERFORMING ORGANIZATION NAME AND ADDRESS U.S. Army Engineer District, St. Louis Dam Inventory and Inspection Section, LMSED-PD 210 Tucker Blvd., North, St. Louis, Mo. 63101		10. PROGRAM ELEMENT, PROJECT, TASK AREA & WORK UNIT NUMBERS 11	
11. CONTROLLING OFFICE NAME AND ADDRESS U.S. Army Engineer District, St. Louis Dam Inventory and Inspection Section, LMSED-PD 210 Tucker Blvd., North, St. Louis, Mo. 63101		12. REPORT DATE December 30 80	
14. MONITORING AGENCY NAME & ADDRESS (if different from Controlling Office) 16 National Dam Safety Program. Smith Lake Dam (MO 11124), Mississippi - Salt - Quincy River Basin, Pike County, Missouri. Phase I Inspection Report.		13. NUMBER OF PAGES Approximately 70	
16. DI Approved for release; distribution unlimited. CIC Walter - 1/21/81		15. SECURITY CLASS. (of this report) UNCLASSIFIED	
17. DISTRIBUTION STATEMENT (of the abstract entered in block 20, if different from report) 15 84		15a. DECLASSIFICATION/DOWNGRADING SCHEDULE	
18. SUPPLEMENTARY NOTES D TIC ELECTE 0070 1981 H			
19. KEY WORDS (Continue on reverse side if necessary and identify by block number) Dam Safety, Lake, Dam Inspection, Private Dams			
20. ABSTRACT (Continue on reverse side if necessary and identify by block number) This report was prepared under the National Program of Inspection of Non-Federal Dams. This report assesses the general condition of the dam with respect to safety, based on available data and on visual inspection, to determine if the dam poses hazards to human life or property.			

DD FORM 1 JAN 73 1473

EDITION OF 1 NOV 65 IS OBSOLETE

UNCLASSIFIED

SECURITY CLASSIFICATION OF THIS PAGE (When Data Entered)

410553

SECURITY CLASSIFICATION OF THIS PAGE(When Data Entered)



SECURITY CLASSIFICATION OF THIS PAGE(When Data Entered)

REF  
all  
Ch  
bas  
sym  
COM  
Blac  
retrie  
uncle  
"Ab  
shou  
title  
Make  
date  
as  
are  
orde  
of th  
whic  
of th  
repe  
Dep  
"Re  
und  
con  
Tec  
offi  
the  
abb  
Dis  
Ine  
und  
...  
su  
of  
tr  
re  
it  
AD



REPLY TO  
ATTENTION OF

**DEPARTMENT OF THE ARMY**  
**ST. LOUIS DISTRICT, CORPS OF ENGINEERS**  
210 TUCKER BOULEVARD, NORTH  
ST. LOUIS, MISSOURI 63101

SUBJECT: Smith Lake Dam (Mo. 11124) Phase I Inspection Report

This report presents the results of field inspection and evaluation of the Smith Lake Dam (Mo. 11124).

It was prepared under the National Program of Inspection of Non-Federal Dams.

**SIGNED**

SUBMITTED BY: \_\_\_\_\_  
Chief, Engineering Division

**18 DEC 1980**  
\_\_\_\_\_  
Date

APPROVED BY: \_\_\_\_\_  
Colonel, CE District Engineer

**22 DEC 1980**  
\_\_\_\_\_  
Date

ACCEPTED FOR  
NTIS  
ENGINEERING  
INFORMATION  
SERVICES  
11/18/80

A

SMITH LAKE DAM  
PIKE COUNTY, MISSOURI

MISSOURI INVENTORY NO. 11124

PHASE I INSPECTION REPORT  
NATIONAL DAM SAFETY PROGRAM

PREPARED BY  
CONSOER, TOWNSEND AND ASSOCIATES, LTD.  
ST. LOUIS, MISSOURI  
AND  
PRC ENGINEERING CONSULTANTS, INC.  
ENGLEWOOD, COLORADO  
A JOINT VENTURE

UNDER DIRECTION OF  
ST. LOUIS DISTRICT, CORPS OF ENGINEERS  
FOR  
GOVERNOR OF MISSOURI

DECEMBER 1980

PHASE I INSPECTION REPORT  
NATIONAL DAM SAFETY PROGRAM

Name of Dam: Smith Lake Dam, Missouri Inv. No. 11124  
State Located: Missouri  
County Located: Pike  
Stream: An unnamed tributary of Noix Creek  
Date of Inspection: July 8, 1980

Assessment of General Condition

Smith Lake Dam was inspected by the engineering firms of Consoer, Townsend and Associates, Ltd. and PRC Engineering Consultants, Inc. (A Joint Venture) of St. Louis, Missouri according to the U. S. Army Corps of Engineers "Recommended Guidelines for Safety Inspection of Dams" and additional guidelines furnished by the St. Louis District of the Corps of Engineers. Based upon the criteria in the guidelines, the dam is in the high hazard potential classification, which means that loss of life and appreciable property loss could occur in the event of failure of the dam. Within the estimated damage zone of half a mile downstream of the dam are nine dwellings, two trailers, a railroad bridge, and a state highway (Hwy 79), which may be subjected to flooding, with possible damage and/or destruction, and possible loss of life. Smith Lake Dam is in the small size classification since it is less than 40 feet and more than 25 feet high, and impounds 49 acre-feet of water.

The inspection and evaluation by the consultant's inspection team indicate that the spillway of Smith Lake Dam does not meet the criteria set forth in the guidelines for a dam having the above size and hazard potential. Smith Lake Dam being a small size dam with a high hazard potential is required by the guidelines to pass from one-half of the Probable Maximum Flood to the Probable Maximum Flood without overtopping. Considering the number of inhabited dwellings and a major highway being located within half a mile downstream of the dam, the PMF is considered the appropriate spillway design flood for Smith Lake Dam. The Probable Maximum Flood is defined as the flood discharge that may be expected from the most severe combination of critical meteorological and hydrologic conditions that are reasonably possible in the region. It was determined that the reservoir/spillway system can accommodate approximately 65 percent of the Probable Maximum Flood without overtopping the dam. The evaluation also indicates that the reservoir/spillway system can accommodate the one-percent chance flood (100-year flood) without overtopping.

Other deficiencies noted by the inspection team were: the dumping of quarry spoils onto the downstream face and the top of dam, the trees and bushes in the spillway channel, the erosion in the spillway channel, lack of protection on the top of dam against surface runoff erosion, the cracks on the top of dam and downstream slope, the erosion gullies on the downstream slope, the trees growing on the dam embankment, the possible seepage areas downstream of the toe of the dam, the tall vegetation on the downstream slope, a need for periodic inspection by a qualified engineer and a lack of a maintenance schedule. The lack of seepage and stability analyses on record is also a deficiency that should be corrected. All burrowing animals should be eliminated from the embankment.

It is recommended that the owner take action to correct or control the deficiencies described above.

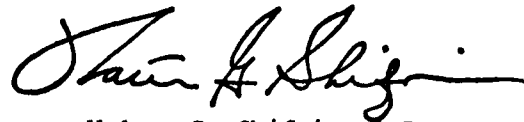

Walter G. Shifrin, P.E.





View looking up the crevice.

NATIONAL DAM SAFETY PROGRAM

SMITH LAKE DAM, I.D. No. 11124

TABLE OF CONTENTS

<u>Sect. No.</u>	<u>Title</u>	<u>Page</u>
SECTION 1	PROJECT INFORMATION . . . . .	1
	1.1 General . . . . .	1
	1.2 Description of Project . . . . .	3
	1.3 Pertinent Data . . . . .	7
SECTION 2	ENGINEERING DATA . . . . .	10
	2.1 Design . . . . .	10
	2.2 Construction . . . . .	10
	2.3 Operation . . . . .	10
	2.4 Evaluation . . . . .	10
SECTION 3	VISUAL INSPECTION . . . . .	12
	3.1 Findings . . . . .	12
	3.2 Evaluation . . . . .	18

TABLE OF CONTENTS

(Continued)

<u>Sect. No.</u>	<u>Title</u>	<u>Page</u>
SECTION 4	OPERATION PROCEDURES . . . . .	21
	4.1 Procedures . . . . .	21
	4.2 Maintenance of Dam . . . . .	21
	4.3 Maintenance of Operating Facilities . . . . .	21
	4.4 Description of Any Warning System in Effect . . . . .	21
	4.5 Evaluation . . . . .	22
SECTION 5	HYDRAULIC/HYDROLOGIC . . . . .	23
	5.1 Evaluation of Features . . . . .	23
SECTION 6	STRUCTURAL STABILITY. . . . .	26
	6.1 Evaluation of Structural Stability. . . . .	26
SECTION 7	ASSESSMENT/REMEDIAL MEASURES. . . . .	29
	7.1 Dam Assessment . . . . .	29
	7.2 Remedial Measures. . . . .	31

TABLE OF CONTENTS

(Continued)

LIST OF PLATES

	<u>Plate No.</u>
LOCATION MAP . . . . .	1
DRAINAGE BASIN AND DOWNSTREAM HAZARD ZONE . . . . .	1A
PLAN AND ELEVATION OF DAM . . . . .	2
MAXIMUM SECTION OF DAM AND SPILLWAY PROFILE. . . . .	3
GEOLOGIC MAP . . . . .	4-5
SEISMIC ZONE MAP . . . . .	6

APPENDICES

- APPENDIX A - PHOTOGRAPHS
- APPENDIX B - HYDROLOGIC AND HYDRAULIC COMPUTATIONS

PHASE I INSPECTION REPORT  
NATIONAL DAM SAFETY PROGRAM

SMITH LAKE DAM, Missouri Inv. No. 11124

SECTION 1: PROJECT INFORMATION

1.1 General

a. Authority

The Dam Inspection Act, Public Law 92-367 of August, 1972, authorizes the Secretary of the Army, through the Corps of Engineers, to initiate a national program of dam inspections. Inspection for Smith Lake Dam was carried out under Contract DACW 43-80-C-0094 between the Department of the Army, St. Louis District, Corps of Engineers, and the engineering firms of Consoer, Townsend & Associates, Ltd., and PRC Engineering Consultants, Inc. (A Joint Venture), of St. Louis, Missouri.

b. Purpose of Inspection

The visual inspection of Smith Lake Dam was made on July 8, 1980. The purpose of the inspection was to make a general assessment as to the structural integrity and operational adequacy of the dam embankment and its appurtenant structures.

c. Scope of Report

This report summarizes available pertinent data relating to the project, presents a summary of visual observations made during the field inspection, presents an assessment of hydrologic and hydraulic conditions at the site, and of the structural adequacy of the various project features and assesses the general condition of the dam with respect to safety.

Subsurface investigations, laboratory testing and detailed analyses were not within the scope of this study. No warranty as to the absolute safety of the project features is implied by the conclusions presented in this report.

It should be noted that in this report reference to left or right abutments is viewed as looking downstream. Where left abutment or left side of the dam is used in this report, this also refers to the west abutment or side, and right to the east abutment or side.

d. Evaluation Criteria

The inspection and evaluation of the dam is performed in accordance with the U.S. Army Corps of Engineers "Recommended Guidelines for Safety Inspection of Dams" and additional guidelines furnished by the St. Louis District office of the Corps of Engineers for Phase 1 Dam Inspection.

1.2

Description of the Project

a. Description of Dam and Appurtenances

The following description is based exclusively upon observations and measurements made during the visual inspection and conversations with Mr. Jerry Smith, the owner's representative. It should be noted that neither design drawings nor "as-built" drawings were available for the dam or appurtenant structures.

The dam is a compacted earthfill structure between earth abutments. Plate 2 shows a plan and elevation of the dam and Photos 1 through 3 show views of the dam. The top of dam varies in width along the axis of the dam. The top width is 35 feet for a distance of 150 feet to the right of the spillway while the remainder of the top of dam has been disguised by the dumping of fill material over the downstream face. Hence, the top of dam increases to 54-feet wide for the next 200 feet to the right and increases to 150 feet wide for the remaining 60 feet. The total length of the dam is 410 feet between the right abutment and the spillway. The top of dam is fairly level along the 35-foot wide section; the tops of the other two sections step up 2 feet and 5 feet, respectively, in relation to the 35-foot wide section. The minimum top of dam elevation at the 35-foot wide section is assumed to be at 581 feet above mean sea level (M.S.L.). The maximum structural height of the dam is 31 feet. The downstream slope of the embankment was measured as 1 vertical to 1.5 horizontal (1V on 1.5H) along most of the dam. The upstream slope of the embankment was measured as 1V on 2.25H from the crest to the water surface. No riprap was placed on the upstream slope.

There is only one spillway for this dam. The spillway is an earthcut, uncontrolled, open channel and is cut into the left abutment of the dam. The spillway is trapezoidal in shape with a top width of 25 feet, a bottom width of 10 feet and side slopes of approximately 1V on 2H (see plate 2). The crest of the spillway is 4 feet below the minimum top of dam. Flows through the spillway are directed away from the embankment by a training berm which extends at a right angle to the embankment for a distance of 250 feet downstream. The training berm is located on the right side of the spillway channel. The spillway channel slopes at about a 1 percent grade. At the downstream end of the channel, the channel makes a 90° bend in order to connect to the natural downstream channel.

No low level outlets or outlet works were provided for this dam.

b. Location

Smith Lake Dam is located in Pike County in the State of Missouri, and crosses an unnamed tributary of Noix Creek. The City of Louisiana is about one mile to the northwest. The Smith Lake Dam location on the 7.5 minute series of the U.S. Geological Survey maps is found in Section 20 of Township 54 North, Range 1 West, of the Louisiana, Missouri-Illinois Quadrangle Sheet.

c. Size Classification

The impoundment of Smith Lake Dam is 49 acre-feet, and the height is within the 25 to 40 foot range. Therefore, the size is determined to fall within the "small" category, according to the "Recommended Guidelines for Safety Inspection of Dams" by the U.S. Department of the Army, Office of the Chief Engineer.

d. Hazard Classification

The dam has been classified as having a "high" hazard potential in the National Inventory of Dams, on the basis that in the event of failure of the dam or its appurtenances, excessive damage could occur to downstream property, together with the possibility of the loss of life. Our findings concur with this classification. Within the estimated damage zone, extending half a mile downstream of the dam, are nine dwellings, two trailers, a railroad bridge and a State highway (Hwy 79).

e. Ownership

Smith Lake Dam is owned privately by Wayne B. Smith, Inc. The mailing address is as follows: Highway 79, Louisiana, Missouri 63553.

f. Purpose of Dam

Smith Lake Dam was constructed originally by a Cement Plant owner as a water source for his plant operations. At present, the lake is used only for recreation.

g. Design and Construction History

According to Mr. Jerry Smith, the dam was built in 1903 with horse drawn wooden scrapers. Under the present owner, the dam was partially rebuilt in 1963 and enlarged to its present size. No design drawings or calculations were available for either the original construction or the reconstruction in 1963.

h. Normal Operational Procedures

Normal procedure is to allow the lake to remain as full as possible with the water level being controlled by rainfall, runoff, evaporation and the elevation of the spillway crest.

1.3 Pertinent Data

a. Drainage Area (square miles):. . . . . 0.07

b. Discharge at Damsite

Estimated experienced maximum flood (cfs):. . . . . 70

Estimated ungated spillway capacity with  
reservoir at top of dam elevation (cfs):. . . . . 393

c. Elevation (Feet above M.S.L.)

Top of dam (minimum):\* . . . . . 581

Spillway crest:. . . . . 577

Normal Pool: . . . . . 577

Maximum Experienced Pool:. . . . . 578.5

Observed Pool: . . . . . 575.5

d. Reservoir

Length of pool with water surface  
at top of dam elevation (feet):. . . . . 750

e. Storage (Acre-Feet)

Top of dam (minimum):. . . . . 49

Spillway crest:. . . . . 33

Normal Pool: . . . . . 33

Maximum Experienced Pool:. . . . . 39

Observed Pool: . . . . . 29

f. Reservoir Surfaces (Acres)

Top of dam (minimum):. . . . . 4.5

Spillway crest:. . . . . 3.5

Normal Pool: . . . . . 3.5

Maximum Experienced Pool:. . . . . 3.8

Observed Pool: . . . . . 3.3



\*\* The hydraulic height of the dam is the vertical distance from the lowest point on the downstream toe to the top of dam or the maximum water surface, if below the top of dam.

## SECTION 2: ENGINEERING DATA

### 2.1 Design

No engineering plans, specifications, or "as-built" drawings were available for Smith Lake Dam. It is doubtful if any design was performed for the original construction in 1903 or the reconstruction in 1963.

### 2.2 Construction

No documented data is available concerning the construction of the dam and appurtenant structures, however, information was obtained from Mr. Jerry Smith concerning the reconstruction of the dam. Mr. Smith stated that the compaction was achieved by activity of the earth moving equipment across the dam. The material used for the embankment was a clay mixed with gravel which was taken from the area to the right of the dam.

### 2.3 Operation

No operational records are available for Smith Lake Dam.

### 2.4 Evaluation

#### a. Availability

The availability of engineering data is poor and consists only of State Geological Maps, a general soil maps of the state of Missouri published by the Soil Conservation Service, and U.S.G.S. Quadrangle sheets. In addition, no

pertinent data were available for review of hydrology, spillway capacity or flood routing through the reservoir. Seepage and stability analyses comparable to the requirements of the "Recommended Guidelines for Safety Inspection of Dams" were not available.

b. Adequacy

The lack of engineering data did not allow for a definitive review and evaluation. Therefore, the adequacy of this dam could not be assessed from the standpoint of reviewing and evaluating design, operation, and construction data, but is based primarily on visual inspection, past performance and present condition of the dam, and sound engineering judgement.

Seepage and stability analyses comparable to the requirements of the "Recommended Guidelines for Safety Inspection of Dams" were not available, which is considered a deficiency. These seepage and stability analyses should be performed for appropriate loading condition and made a matter of record.

c. Validity

No valid engineering data were available.

SECTION 3: VISUAL INSPECTION

3.1 Findings

a. General

A visual inspection of the Smith Lake Dam was made on July 8, 1980. The following persons were present during the inspection:

<u>Name</u>	<u>Affiliation</u>	<u>Disciplines</u>
Dr. M.A. Samad	PRC Engineering Consultants, Inc.	Project Engineer, Hydraulics and Hydrology
Mark Haynes, P.E.	PRC Engineering Consultants, Inc.	Civil and Mechanical
Razi Quraishi, R.P.G.	PRC Engineering Consultants, Inc.	Geology
Zoran Batchko	PRC Engineering Consultants, Inc.	Soils
Kevin J. Blume	Consoer, Townsend & Assoc., Ltd.	Civil and Structural
Jerry Smith	Owner's Representative	

Specific observations are discussed below.

b. Dam

Only the upstream face of the dam has a vegetative cover which adequately protects the embankment material against surface runoff erosion (see photo 1). The upstream face is not protected by riprap, however, because of accumulated debris and the high water level, it was not possible to evaluate the extent of wave erosion, if any. There were a significant number of trees and large bushes observed on the upstream face of the dam. No cracks, bulges or depressions indicative of an instability of the slope were apparent.

The downstream embankment slope is generally unprotected by any vegetation (see Photo 3). Erosion gullies up to 6 feet deep and 3 feet wide were observed at several locations across the downstream slope (see Photo 4). Smaller erosion gullies on the order of about 1 foot deep were more frequent. The left 1/3 of the embankment slope adjacent to the spillway channel has medium sized trees growing on it. Some small rodent holes were observed on the slope. No cracks, bulges or depressions indicative of an instability of the slope were apparent.

The top of dam is generally irregular in shape and profile with a sparse vegetation cover (see Photo 2). The irregularity of the top of dam appears to be due to the practice of dumping materials on the top of dam and the downstream slope and not to an instability of the embankment. The vegetation growing on the crest is typically large weeds and a few small trees. Large shrinkage cracks on the order of 1/2 inch wide, up to 6 feet long, and 8 to 12 inches deep were observed over the major portion of the embankment crest and downstream face. According to the owner, the dam has never been overtopped and no evidence indicating the contrary was

observed.

There is no evidence of seepage or leakage through the embankment or foundation, however, several localized wet spots were encountered beyond the toe of the dam in the densely vegetated downstream area. It was undetermined whether these wet areas were due to seepage through the foundation or attributed to the recent heavy rains that occurred several days prior to our site inspection. No measurable flow was observed.

No signs of present instability were seen on the embankment or in the foundation. It should be kept in mind though, that periodic dumping on the downstream face from the owner's quarry operation could be masking an instability problem if one does exist. A portion of the dam, however, was reconstructed in the early 1960's due to a failure of the dam.

The left abutment is steeply sloped upward from the top of the dam. The right abutment is level for approximately 50 feet to the right of the dam, which is the access road to the dam, and then slopes moderately upward. The right abutment area directly east of the dam was used at one time as a rock quarry (see Photo 9). No instabilities, seepage or erosion were observed on either abutment.

c. Project Geology and Soils

(1) Project Geology

The damsite is located on an unnamed tributary of Noix Creek in the Dissected Till Plains Section of the Central Lowland Physiographic Province. Loess-mantled Kansas drift covers the surface of most of the Dissected Till Plains

Section. This section is distinguished from the Young Drift Section to the north and from the Till Plains on the east by the stage it has reached in the post-glacial erosion cycle. Broadly generalized, this section is a nearly flat till plain submature to mature in its erosion cycle.

The topography at the damsite is hilly with V- to U-shaped valleys. Elevation of the ground surface ranges from 580 feet above M.S.L. at the damsite to 834 feet above M.S.L. approximately 1.2 miles southwest of the damsite. The reservoir slopes are in the range of  $10^{\circ}$  to  $25^{\circ}$  from the horizontal and appear to be stable. The area near the damsite is covered with slope wash of glacial-fluvial deposits and loess.

The regional bedrock geology beneath the glacial outwash deposit in the damsite area as shown on the Geologic Map of Missouri (1979), (see Plate 4), consists of Pennsylvanian Marmaton-Cherokee Group (cyclic deposits of shale, limestone, and sandstone), Mississippian age Burlington Limestone, Mississippian Chouteau Group, Devonian Louisiana Formation, Silurian Bowling Green Limestone, and Ordovician rocks consisting of Maquoketa Shale, Kimmswick Limestone, Decorah Formation and St. Peter Sandstone.

The predominant bedrock in the site vicinity underlying the glacial-fluvial deposits are the Mississippian Burlington Limestone and Mississippian Chouteau Group of rocks consisting of interbedded limestones, cherty limestones, and siltstones. The inlet and outlet areas of the unnamed tributary of the Noix Creek contains Quaternary alluvium. An outcrop of horizontally bedded Mississippian Burlington Limestone (slightly weathered, brownish gray, very hard, cherty limestone), is exposed in a hill cut east of the right abutment (see Photos 9 and 10).

No faults have been identified in the vicinity of the damsite. The closest trace of a fault to the damsite is the Cap Au Gres faulted flexure nearly 18 miles south of the site. The Cap Au Gres faulted flexure had its last movement in post-Pennsylvanian, pre-Pleistocene time. Thus, the fault has no effect on the dam.

Smith Lake Dam consists of a homogeneous earthfill embankment and a spillway located at the left abutment. Based on the visual inspection and conversations with Mr. Jerry Smith, the embankment probably rests on the Mississippian Burlington Limestone bedrock. The spillway was cut into the glacial-fluvial deposits consisting of greenish yellow to brown, clayey silt. A localized slide scar was observed at the reservoir rim near the left abutment. This scar appears to have no detrimental effect on the stability of the reservoir bank.

## (2) Project Soils

According to the "Missouri General Soil Map and Soil Association Descriptions" published by the Soil Conservation Service, the materials in the general area of the dam belong to the soil series of Menfro-Winfield-Lindley in the Central Mississippi Valley Wooded Slopes family. The soils were basically formed from loess and glacial till. The permeability of these soils ranges from moderate to moderately slow. Field observations indicate that the moderately to high erodible Lindley type soils were used to construct the embankment. Overtopping of the dam would increase the potential for failure of the embankment due to erosion of the dam.

The material removed from the embankment was a brown and tan, sandy clay with traces of fine gravel. Based upon the Unified Soil Classification System, the soil would probably be classified as a CL. This soil type generally has the following characteristics: semipervious to impervious with a coefficient of permeability less than 100 feet per year, medium shear strength, and an intermediate resistance to piping.

d. Appurtenant Structures

(1) Spillway

The spillway channel was found obstructed with trees and bushes (see Photos 5 and 6). No erosion or instabilities of the side slopes of the channel were observed in the channel near the embankment, however, approximately 150 feet downstream of the embankment, considerable erosion has occurred in the channel and at the toe of the training berm. The erosional scarp extended across the entire width of the channel and was observed to be up to 7 feet deep. A comprehensive inspection of the spillway was hampered due to the heavy growth of vegetation in the spillway channel.

(2) Outlet Works

There are no regulated low level outlets or outlet works provided for this dam.

e. Reservoir Area

The reservoir water surface elevation at the time of inspection was approximately 575.5 feet above M.S.L.

The surface area of the reservoir at the normal pool elevation is about 3.5 acres. The reservoir rim area is generally heavily wooded (see Photo 8). The left side of the reservoir is moderately to steeply sloping with trees and woods extending to the rim of the reservoir. The right side of the reservoir is bounded by an access road beyond which lies moderately sloping hills. The upstream and downstream valleys are gently sloping and heavily wooded, also. There was no apparent evidence of instability in the reservoir rim area except for the localized slide scar mentioned in Section 3.1.c(1). There are no houses built in close proximity to the reservoir.

f. Downstream Channel

The downstream channel, which carries flows from the spillway, is overgrown with tall vegetation and is also obstructed by trees (see Photo 7). The channel varies in width from 20 to 50 feet and has side slopes of 1V to 1H. The channel is about 6 to 10 feet deep. Minor erosion was observed in the channel. The heavy growth of vegetation on the channel will affect the hydraulic efficiency of the channel.

3.2 Evaluation

The visual inspection uncovered nothing of a consequential nature which would require immediate remedial action. However, the following conditions were observed which could adversely affect the dam and the spillway.

1. The erosion of the downstream face does not affect the structural stability of the dam in its present condition, however, if the condition was to go unchecked, the condition could only worsen and jeopardize the safety of the dam.

2. It is recommended that trees and bushes be prevented from growing on the dam embankments. Depending upon the extent of the root system, the tree roots present possible paths for piping through the embankment which could endanger the safety of the dam. The root systems can also do damage to the embankment from being uprooted by a storm.

3. The rodent activity observed on the embankment could jeopardize the safety of the dam. The holes created by the animals make avenues for possible piping.

4. The source of the wet areas downstream of the embankment was unknown. Nevertheless, if the wet areas are due to seepage through the foundation of the dam, the stability of the dam could be in jeopardy. Seepage can transport soil particles which could cause piping of the foundation material. This could lead to an eventual failure of the embankment.

5. The upstream slope has no riprap protection, however, the extent of damage to the slope due to wave action, if any, is unknown.

6. The top of dam and the downstream slope are not adequately protected from surface runoff erosion which poses a potential danger to the safety of the dam.

7. Loose dumping of quarry spoils onto the downstream face is not a recommended practice. If continued, this practice could conceal serious problems, such as the 6 foot deep erosion gullies or the rodent activity, allowing them to go undetected.

8. The fractures and cracking on the crest and downstream face of the dam could conceivably become progressively worse due to freeze-thaw cycles and surface runoff erosion in the future if left in the "as is" condition. Nevertheless, they do not appear to pose a threat to the stability of the dam in their present condition nor are they indicative of an instability of the embankment.

9. The obstruction of the trees and bushes in the spillway does affect the hydraulic capability of the spillway and endangers the safety of the dam. The obstruction restricts the flow of water through the spillway, thus increasing the potential of overtopping the dam. This condition, if allowed to continue, can only worsen and further jeopardize the safety of the dam.

10. The erosion in the spillway channel does affect the stability of the channel and training berm. Nevertheless, it does not have an adverse effect on the safety of the dam and does not affect the operation of the spillway in its present condition.

## SECTION 4: OPERATIONAL PROCEDURES

### 4.1 Procedures

Smith Lake Dam is now used for recreational purposes and there are no methods or procedures that are followed for its operation. The water level is controlled by rainfall, runoff, evaporation, and the elevation of the spillway crest.

### 4.2 Maintenance of Dam

There is no program of maintenance for this dam, according to Mr. Jerry Smith. Mr. Smith also informed the inspection team that rock quarry spoils are periodically dumped on the downstream slope. There is an abundance of trees growing on both the upstream and downstream slopes and the top of dam.

### 4.3 Maintenance of Operating Facilities

There are no operating facilities at the damsite.

### 4.4 Description of Any Warning System in Effect

The inspection team is not aware of any warning system in use at the damsite.

4.5      Evaluation

The maintenance at Smith Lake Dam is poor. The remedial measures described in Section 7 should be undertaken to improve the condition of the dam.

## SECTION 5: HYDRAULIC/HYDROLOGIC

### 5.1 Evaluation of Features

#### a. Design Data

No hydrologic and hydraulic design data is available for Smith Lake Dam. The sizes of physical features utilized to develop the stage-outflow relation for the spillway and overtopping of the dam were prepared from field notes and sketches prepared during the field inspection. The reservoir elevation-capacity data were based on the U.S.G.S. Louisiana, Missouri-Illinois Quadrangle topographic map (7.5 minute series). The spillway and overtop release rates and the reservoir elevation capacity data are presented in Appendix B.

The hydrologic soil group of the watershed of Smith Lake Dam was determined from information available in the U.S.D.A. Soil Conservation Service publication "Missouri General Soil Map and Soil Association Descriptions", 1979. The Probable Maximum Precipitation (PMP) used to determine the Probable Maximum Flood (PMF) was determined by using the U.S. Weather Bureau publication, "Hydrometeorological Report No. 33" (April 1956). The 100-year flood was derived from 100-year rainfall of Hannibal, Missouri.

b. Experience Data

It is believed that records of reservoir stage or spillway discharge are not maintained for this site. However, according to the owner, the maximum reservoir level was about 1-1/2 feet above the crest of the spillway.

c. Visual Observations

Observations made of the spillway during the visual inspection are discussed in Section 3.1d and evaluated in Section 3.2.

d. Overtopping Potential

Only the Probable Maximum Flood when routed through the reservoir, resulted in overtopping of the dam. The inflows for the PMF and one-half of the PMF are 1,182 cfs and 591 cfs, respectively. The peak outflow discharges for the PMF and one-half of the PMF are 890 and 243 cfs, respectively. The maximum capacity of the spillway just before overtopping the dam is 393 cfs. The PMF overtopped the dam by 0.75 feet. The total duration of overflow over the dam is 0.42 hours during the occurrence of the PMF. The spillway/reservoir system of Smith Lake Dam is capable of accommodating a flood equal to approximately 65 percent of the PMF just before overtopping the dam. The reservoir/spillway system of Smith Lake Dam will accommodate the one-percent chance flood without overtopping the dam. The surface soils on the embankment appear to be sandy clay and the soils on the spillway appear to be clayey silt. The maximum velocity of flow in the spillway during PMF will be about 6.5 ft/sec. The spillway channel may be subject to erosion due to high velocity of flow during the PMF. The dam may also be susceptible to erosion due to high velocity of

flow on its downstream slope, due to overtopping of the dam during the PMF.

The failure of the dam could cause extensive damage to the property downstream of the dam and possible loss of life. The estimated damage zone extends approximately half a mile downstream of the dam. Within the damage zone are nine dwellings, two trailers, a railroad bridge, and a State highway (Hwy 79).

## SECTION 6: STRUCTURAL STABILITY

### 6.1 Evaluation of Structural Stability

#### a. Visual Observations

There were no major signs of settlement or distress observed on the embankment or foundation during the visual inspection. However, some items which could affect the stability of the dam if not attended to within a reasonable period of time were observed on the embankment which includes the rodent holes, the erosion gullies up to 6 feet deep, the 1 foot deep shrinkage cracks, and the loosely dumped fill. The wet spots observed below the downstream toe of the dam may be indicative of seepage beneath the dam, however, no wet spots were observed on the embankment. The loosely dumped fill on the right portion of the downstream face is at a very steep angle. Furthermore, because the fill is uncompacted, further erosion due to surface runoff is expected to be severe, thus adding to the potential instability. In the absence of seepage and stability analyses, no quantitative evaluation of the structural stability can be made.

The spillway appeared to be structurally stable on the day of the inspection except for the severe erosion at the downstream end of the spillway channel. The erosion does not affect the stability of the dam in its present condition.

b. Design and Construction Data

Design computations pertaining to the embankment were not available during the report preparation phase. Seepage and stability analyses comparable to the requirements of the "Recommended Guidelines for Safety Inspection of Dams" were not available. No embankment or foundation soil parameters were available for carrying out a conventional stability analysis on the embankment. No construction data or specifications relating to the degree of embankment compaction were available for use in a stability analysis.

c. Operating Records

No operating records were available relating to the dam or appurtenant structures. The water level on the day of the visual inspection was approximately 1-1/2 feet below the spillway crest. The normal water level is at the spillway crest. According to Mr. Jerry Smith, the water level fluctuates approximately four feet during the year.

d. Post Construction Changes

The only post construction changes known to exist which could affect the structural stability of the dam are the reconstruction of the embankment in 1963 and the practice of loosely dumping of materials on the downstream slope. It is unknown what effect the reconstruction of the embankment had on the overall structural stability of the dam due to the fact that no engineering data concerning this change exists. The loosely dumping of materials on the downstream slope, even though it is not a recommended practice, could have a positive effect on the structural stability of the dam if proper methods of placing the material are employed.

e. Seismic Stability

The dam is located in Seismic Zone 2, as defined in "Recommended Guidelines For Safety Inspection of Dams" prepared by the Corps of Engineers, and will not require a seismic stability analysis. An earthquake of the magnitude which would be expected in Seismic Zone 2 should not cause significant distress to a well designed and constructed earth dam. Available literature indicates that no active faults exist in the vicinity of the damsite.

## SECTION 7: ASSESSMENT/REMEDIAL MEASURES

### 7.1 Dam Assessment

The assessment of the general condition of the dam is based upon available data and visual inspection. Detailed investigations, testing and detailed computational evaluations are beyond the scope of a Phase I investigation; however, the investigation is intended to identify any need for such studies.

It should be realized that the reported condition of the dam is based upon observations of field conditions at the time of inspection along with data available to the inspection team.

It is also important to note that the condition of a dam depends upon numerous and constantly changing internal and external conditions, and is evolutionary in nature. It would be incorrect to assume that the present condition of the dam will continue to represent the condition of the dam at some point in the future. Only through continued care and inspection can there be assurance that an unsafe condition could be detected.

#### a. Safety

The spillway capacity of Smith Lake Dam is found to be "Inadequate". The spillway/reservoir system will accommodate approximately 65 percent of the PMF without overtopping the dam. The surface soils on the embankment appear to be sandy clay and the soils on the spillway appear to be clayey silt. The dam is overtopped by 0.42 feet during the occurrence of the PMF. The maximum velocity of flow in the spill-

way during PMF will be about 6.5 ft/sec. The spillway channel may be subject to erosion due to high velocity of flow during the PMF. The dam may also be susceptible to erosion due to high velocity of flow on its downstream slope, due to overtopping of the dam during the PMF.

A quantitative evaluation of the safety of the embankment could not be made in view of the absence of seepage and stability analyses. The present embankment and appurtenant structures, however, reportedly have performed satisfactorily since the 1963 reconstruction; there have been no failures or evidence of instability. The dam, reportedly, has never been overtopped and no evidence indicating the contrary was observed. The safety of the dam can be improved if the deficiencies described in Sections 3 and 6.1a are properly corrected as described in Section 7.2.

b. Adequacy of Information

The conclusions presented in this report are based upon field measurement, past performance, and the present condition of the dam. Information on the design hydrology, hydraulic design, or the operation and maintenance of the dam were not available. Seepage and stability analyses comparable to the requirements of the "Recommended Guidelines for Safety Inspection of Dams" were not available, which is considered a deficiency.

c. Urgency

The remedial measures recommended in Paragraph 7.2 should be accomplished within a reasonable period of time, and the item recommended in paragraph 7.2a should be pursued on a high priority basis.

d. Necessity for Phase II Inspection

Based upon results of the Phase I inspection, a Phase II inspection is not felt to be necessary.

7.2 Remedial Measures

a. Alternatives

One of the following mitigation measures should be undertaken under the guidance of a professional engineer experienced in design and construction of earth dams to avoid severe consequences of dam failure from overtopping.

1. Increase the spillway capacity to pass the Probable Maximum Flood without overtopping the dam.
2. Increase the height of the dam enough to pass the PMF without overtopping the dam; an investigation should also be done that includes studying the effects on the structural stability of the existing embankment. The overtopping depth during the occurrence of the PMF, stated in Section 5.1d, is not the required or recommended increase in the height of the dam.
3. A combination of 1 and 2 above.
4. Provide highly reliable flood warning system (generally does not prevent damage but avoids loss of life).

b. O & M Procedures

1. The erosion gullies on the downstream slope should be properly backfilled and the entire slope adequately protected from further erosion.
2. All of the trees should be removed from the embankment. Removal of large trees should be under the guidance of an engineer experienced in the design and construction of earth dams. Indiscriminate clearing could jeopardize the safety of the dam.
3. The extent of damage done to the embankment by burrowing animals, if any, should be determined and make corrective repairs as required. All burrowing animals should be eliminated from the embankment and their burrows properly backfilled and compacted.
4. The wet areas downstream of the toe of the embankment should be monitored to determine the source of the moisture and to ensure the safety of the dam. If the condition is indeed due to seepage, the area should be monitored to detect any changes in location, turbidity and quantity of water. Any changes should be reported and investigated further.
5. The upstream slope should be cleared of all unwanted vegetation, including the trees as mentioned above; the slope properly repaired, if required, and adequately protected against wave action and surface runoff.
6. The top of dam should be adequately protected from surface runoff erosion.

7. The practice of loosely dumping quarry spoils onto the downstream face and top of dam must be discontinued. This practice, if continued, will severely hinder the comprehensive inspection of the dam by concealing possible warning signs which would be otherwise observable.
8. The cracks on the top of dam and downstream slope should be properly repaired and the embankment monitored for further cracking to ensure the safety of the dam.
9. The obstruction created by trees and bushes in the spillway channel should be removed and adequate protective cover retained in the channel.
10. The severe erosion in the spillway channel should be monitored to ensure that it does not jeopardize the stability of the dam and repairs made when deemed necessary.
11. Seepage and stability analyses should be performed by a professional engineer experienced in the design and construction of earth dams.
12. The owner should initiate the following programs:
  - (a) Periodic inspection of the dam by a professional engineer experienced in the design and construction of earth dams.
  - (b) Set up a maintenance schedule and log all visits to the dam for operation, repairs and maintenance.

PLATES

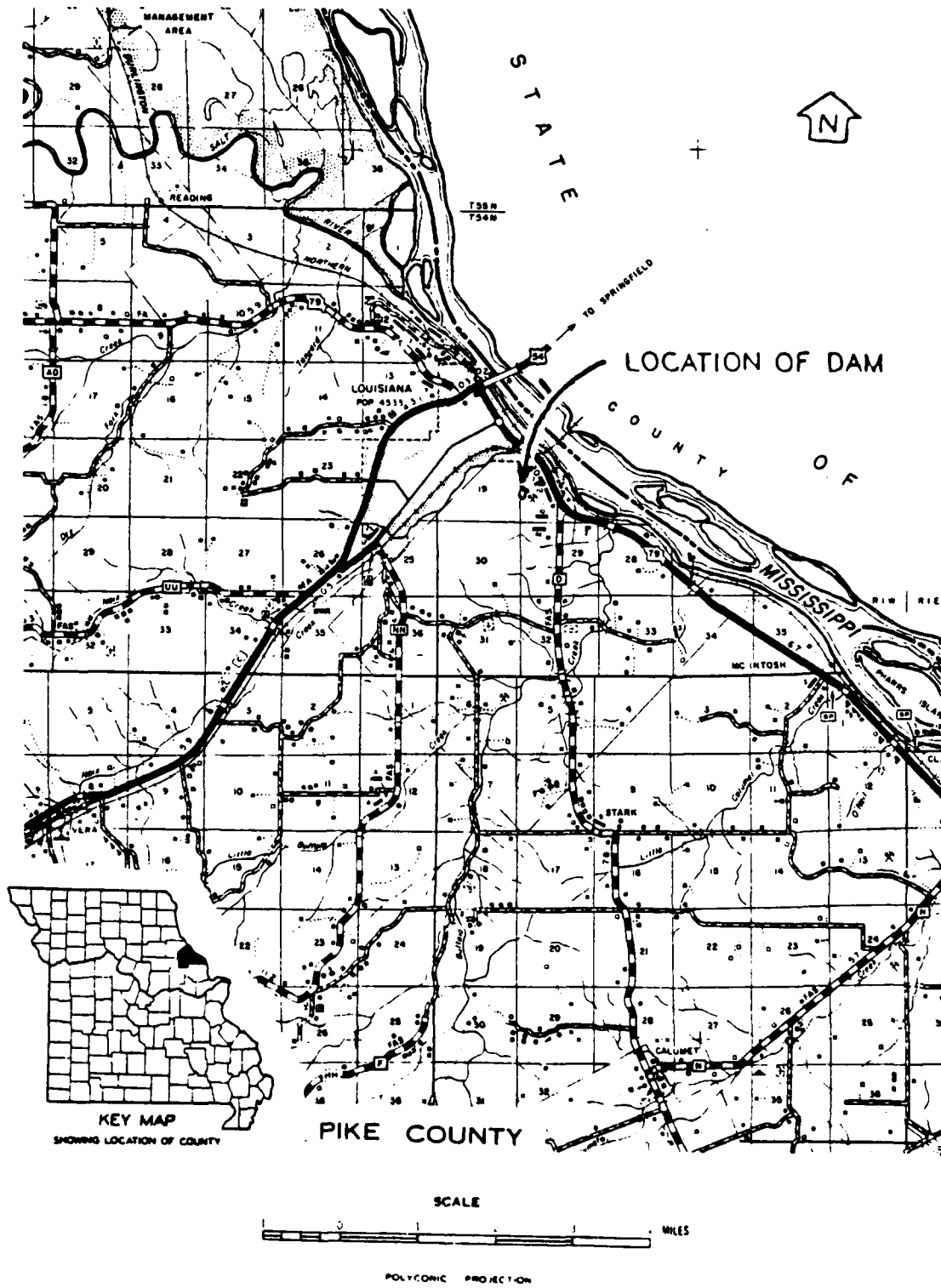

LOCATION MAP - SMITH LAKE DAM

MO.- 11124

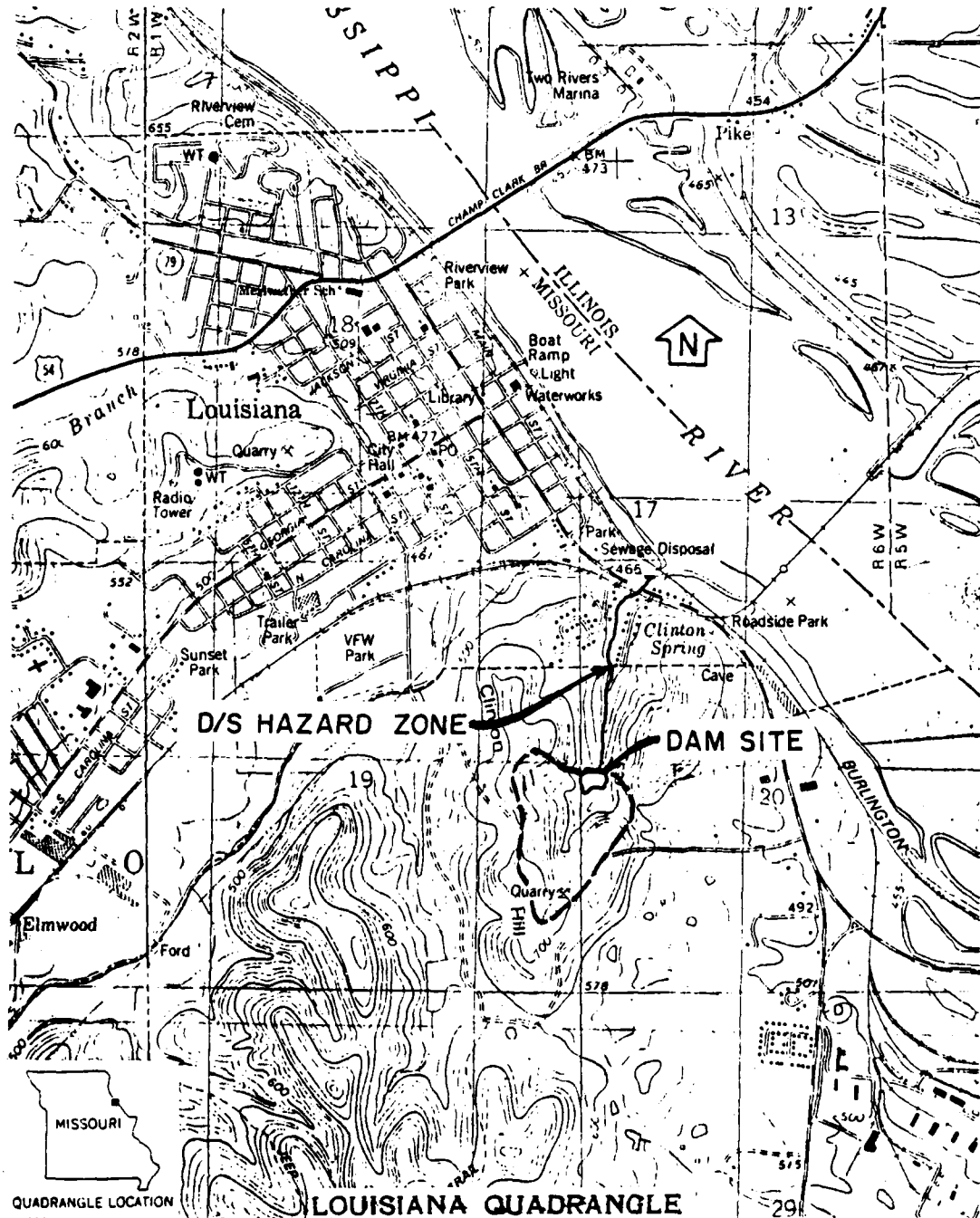

D/S HAZARD ZONE DAM SITE

LOUISIANA QUADRANGLE

SCALE 1:24 000

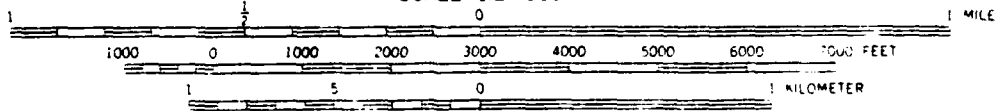

CONTOUR INTERVAL 5 AND 20 FEET  
DATUM IS MEAN SEA LEVEL

DRAINAGE BOUNDARY - - - - -

SMITH LAKE DAM - MO. 11124  
DRAINAGE BASIN AND  
DOWNSTREAM HAZARD ZONE

SCALE:  
HORIZ. 1" = 60'  
VERT. 1" = 5'

RESERVOIR WATER SURFACE EL. 575.5  
OBSERVED ON JULY 8, 1980  
ELEVATION

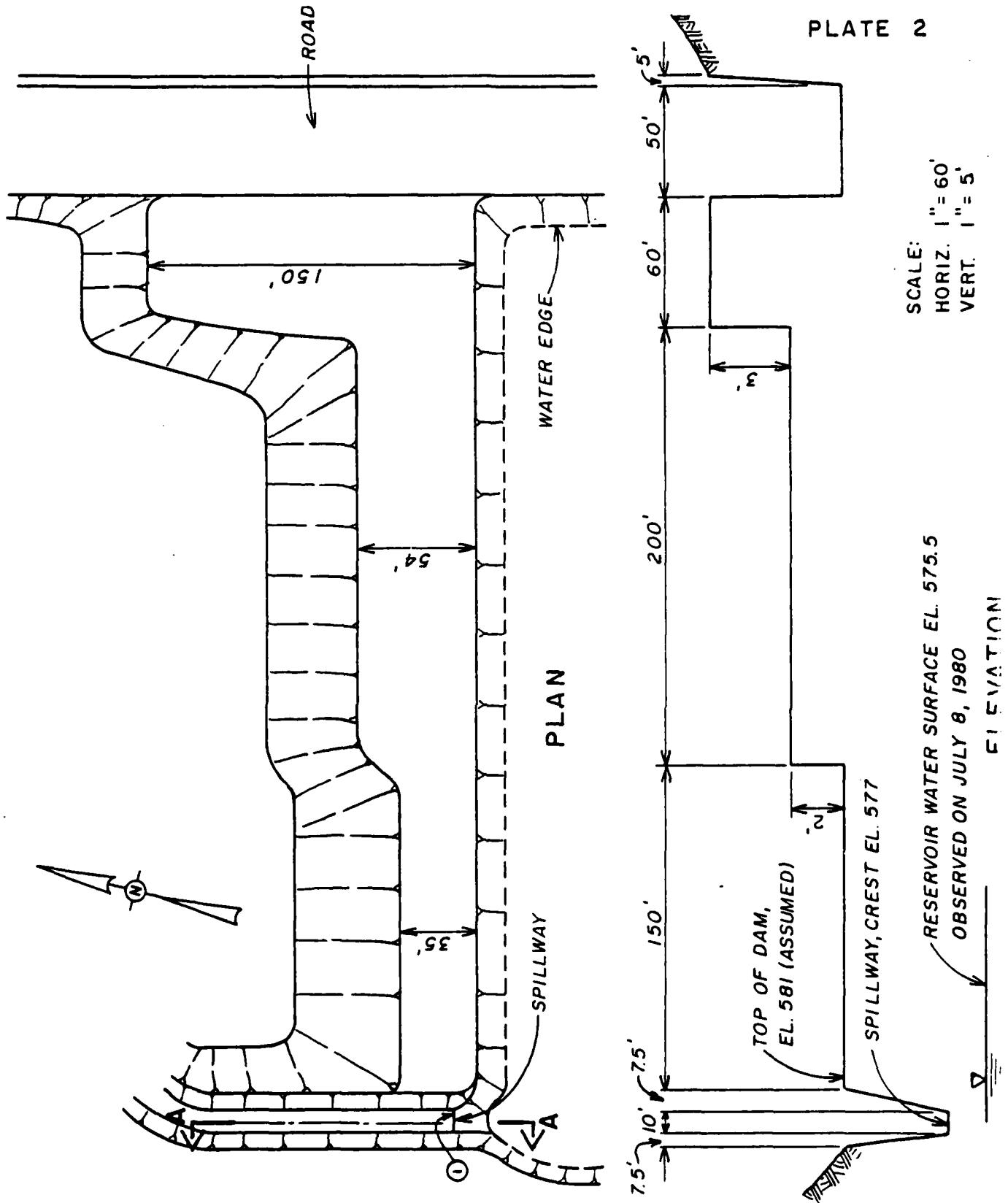

NOTE:  
ALL ELEVATIONS ARE SHOWN  
AS FEET ABOVE M.S.L.

SMITH LAKE DAM (MO. 11124)  
PLAN AND ELEVATION

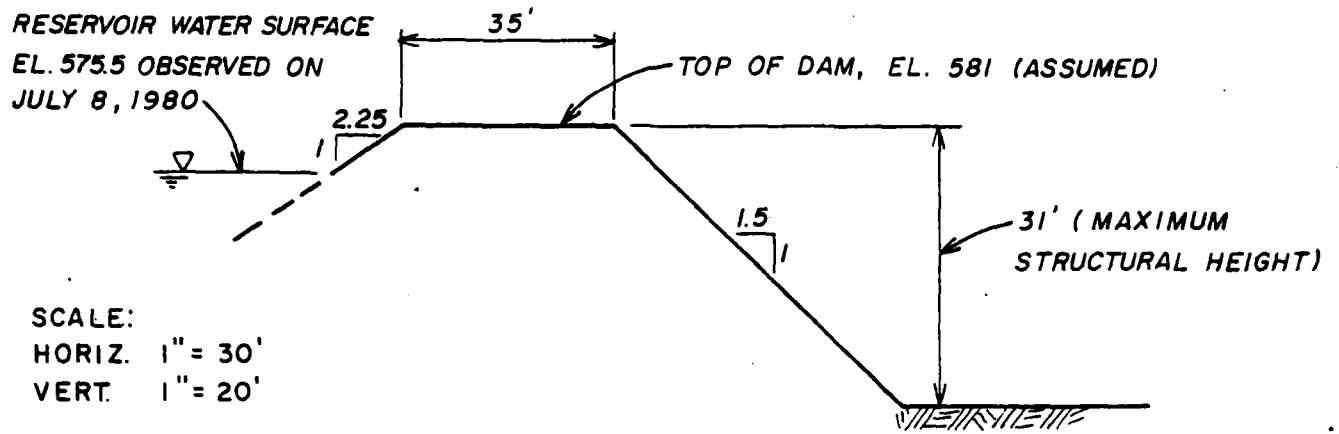

MAXIMUM SECTION

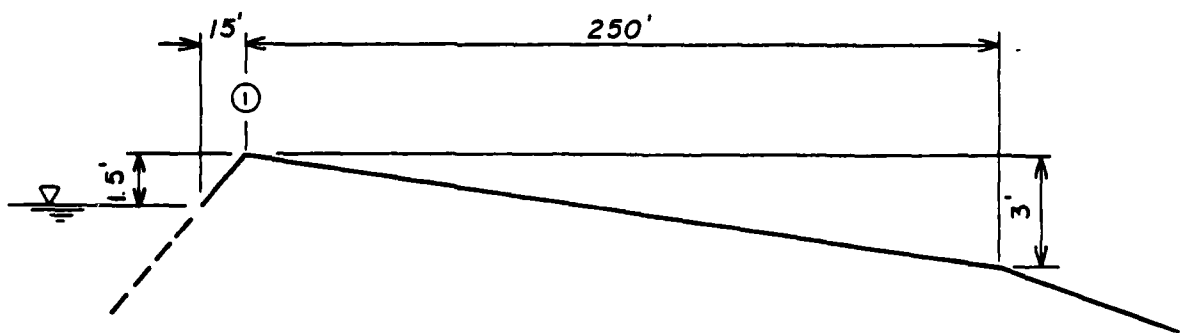

SECTION A-A  
(SPILLWAY PROFILE)

SCALE:  
HORIZ. 1" = 60'  
VERT. 1" = 5'

SMITH LAKE DAM (MO. 11124)  
MAXIMUM SECTION OF EMBANKMENT  
AND SPILLWAY PROFILE

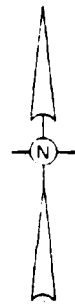
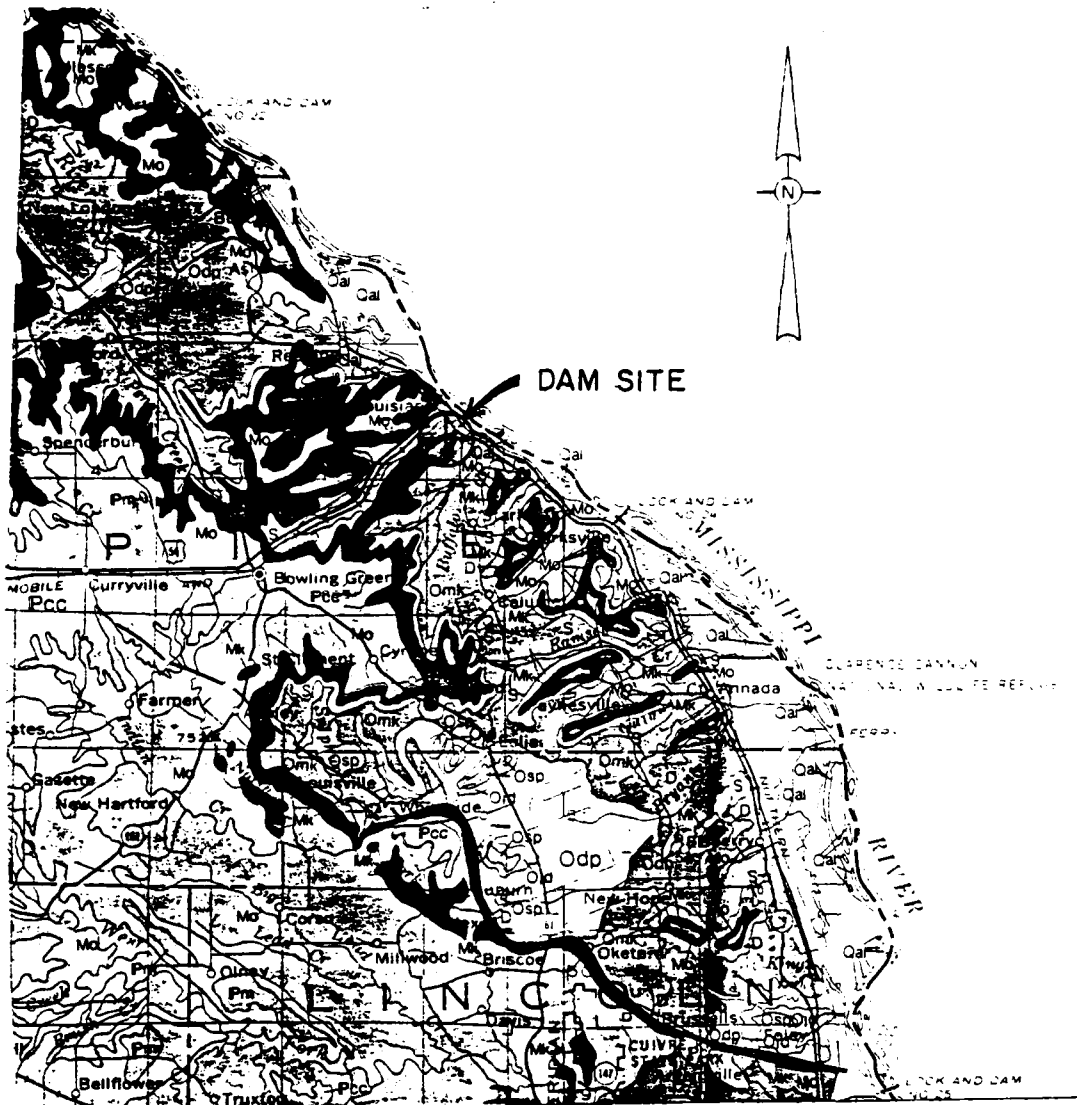

DAM SITE

SCALE



⊕ LOCATION OF DAM

NOTE: LEGEND OF THIS DAM IS ON PLATE 5

REFERENCE:

GEOLOGIC MAP OF MISSOURI  
DEPARTMENT OF NATURAL RESOURCES  
MISSOURI GEOLOGICAL SURVEY  
KENNETH H. ANDERSON, 1979

REGIONAL GEOLOGICAL MAP  
OF  
SMITH LAKE DAM

LEGEND

<u>PERIOD</u>	<u>SYMBOL</u>	<u>DESCRIPTION</u>
QUATERNARY	Qal	ALLUVIUM: SAND, SILT, GRAVEL
PENNSYLVANIAN	Pm	MARMATON GROUP: CYCLIC DEPOSITS OF SHALE, LIMESTONE AND SANDSTONE
	Pcc	CHEROKEE GROUP: CYCLIC DEPOSITS OF SHALE, LIMESTONE AND SANDSTONE
MISSISSIPPIAN	Mo	KEOKUK-BURLINGTON FORMATION: CHERTY GRAYISH BROWN SANDY LIMESTONE
	Mk	CHOUTEAU GROUP: HANNIBAL AND BACHELOR FORMATION (SANDSTONE, SHALE, CHERTY LIMESTONE, DOLOMITE)
DEVONIAN	D	LOUISIANA FORMATION: (INTERBEDDED LIMESTONE, CHERTY LIMESTONE AND SILTSTONE)
SILURIAN	S	BOWLING GREEN LIMESTONE
ORDOVICIAN	Ou	NOIX LIMESTONE
	Omk	MAQUOKETA SHALE, KIMMSWICK LIMESTONE
	Odp	DECORAH FORMATION: GREEN TO GRAY CALCAREOUS SHALE WITH THIN FOSSILIFEROUS LIMESTONE
	Osp	ST PETER SANDSTONE

APPENDIX A

PHOTOGRAPHS

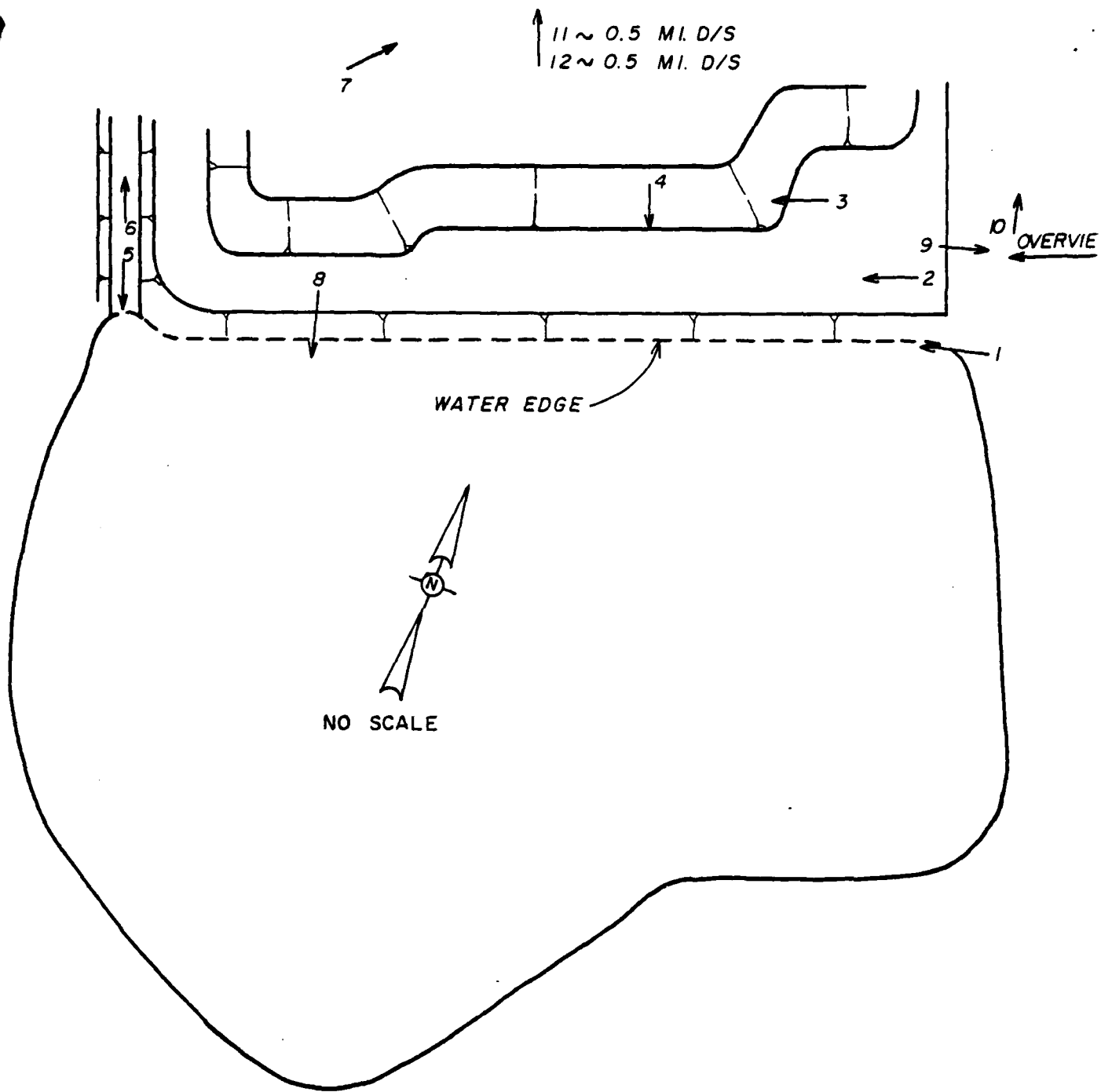

PHOTO INDEX  
FOR  
SMITH LAKE DAM

Smith Lake Dam  
Photographs

- Photo 1 - View of the upstream slope from the right abutment showing the growth of trees and vegetation.
- Photo 2 - View of the top of dam showing irregular shape and sparse vegetative cover.
- Photo 3 - View of the downstream slope showing sparse vegetative cover and trees.
- Photo 4 - Close-up view of erosional gully on the downstream slope.
- Photo 5 - View of the spillway taken from the spillway channel looking back toward the reservoir and showing the obstruction of trees and bushes.
- Photo 6 - View of the spillway channel also showing the obstruction of trees and bushes.
- Photo 7 - View of the downstream channel near the point where the spillway channel intersects the downstream channel.
- Photo 8 - View of the reservoir and rim.
- Photo 9 - View of the rock quarry excavation on the right abutment area adjacent to the dam.
- Photo 10 - Close-up view of the exposed Burlington Limestone in the rock quarry.

Photo 11 - View of a dwelling approximately 0.5 miles downstream of the dam with the downstream channel in the background.

Photo 12 - View of a dwelling approximately 0.5 miles downstream of the dam looking across the downstream channel.

Smith Lake Dam

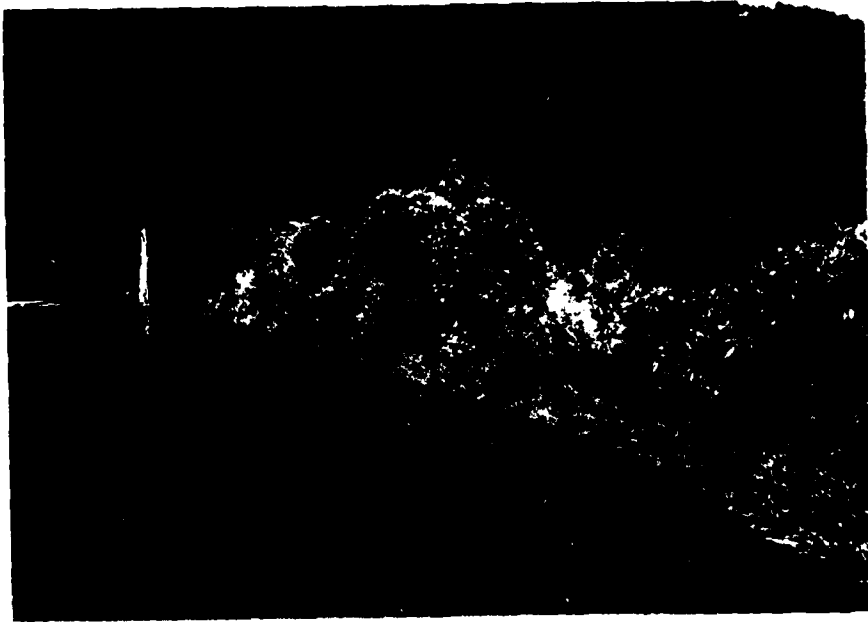

Photo 1



Photo 2

Smith Lake Dam



Photo 3



Photo 4

Smith Lake Dam



Photo 5

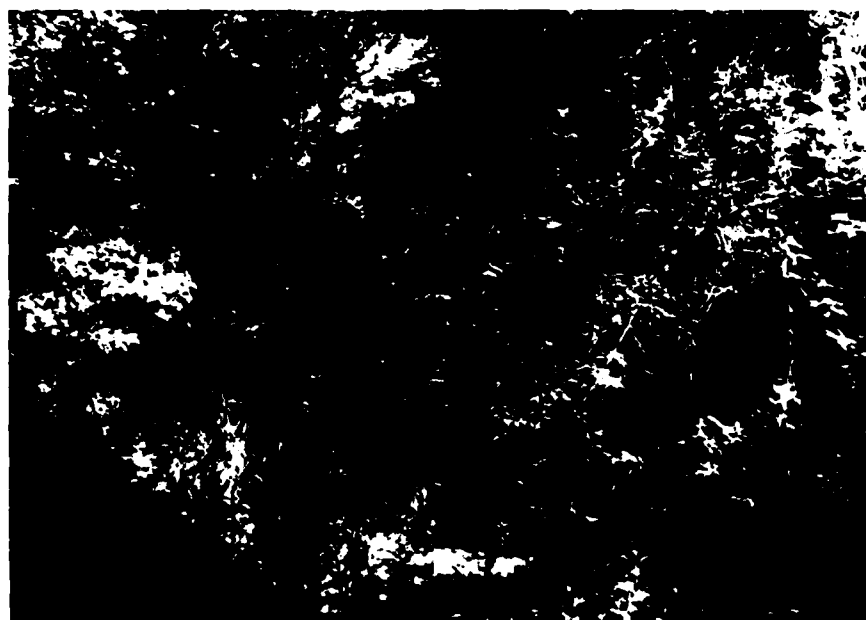

Photo 6

Smith Lake Dam



Photo 7



Photo 8



Photo 9



Photo 10

Smith Lake Dam



Photo 11



Photo 12

APPENDIX B

HYDROLOGIC AND HYDRAULIC COMPUTATIONS

SMITH LAKE DAM

HYDROLOGIC AND HYDRAULIC DATA, ASSUMPTIONS AND METHODOLOGY

1. SCS Unit Hydrograph and HEC-1DB are used to develop the inflow hydrographs, and the hydrologic inputs are as follows:
  - (a) Twenty-four hour probable maximum precipitation from Hydro-meteorological Report No. 33, 24-hour 100-year rainfall of Hannibal, Missouri.
  - (b) Drainage area = 45 acres
  - (c) Lag time = 0.053 hour
  - (d) Hydrologic Soil Group:  
Soil Group "C"
  - (e) Runoff curve number:  
CN = 77 for AMC II and CN = 89 for AMC III
2. Spillway release rates are based on open channel flow assuming Manning's  $n = 0.04$ . Flow rates over the dam are based on broad crested weir equation  $Q = CLH^{3/2}$ .
3. Floods are routed through Smith Lake to determine the capability of its spillway.



DAM SAFETY INSPECTION - MISSOURI

SHEET NO. 2 OF 2

SMITH LAKE DAM - (MO 11124)

JOB NO. 1263

SPILLWAY AND OVERTOP RATING CURVE

BY DC DATE 7/17/90

$C_u$	$Q_u$	$H_u$	$Y_u = \frac{2}{3} \left( \frac{H_u + Y_u}{2} \right)$	$T_u$	$A_u$	$Q_u = \sqrt{\frac{3}{8}} \frac{A_u}{T_u}$	$Q_u$
300	29.78	.34	.27	.27	.037	.077	519
303	120.93	.86	.69	.69	.24	.79	985
304	355.32	1.76	1.41	1.41	.99	4.72	2126
305	490.35	2.18	1.74	1.74	1.52	8.06	2815
306	784.92	2.98	2.38	2.38	2.54	17.6	4746
306	1425.5	4.43	3.54	3.54	6.28	47.44	9459

HEC-2 INPUT AND SUMMARY TABLE



HEC2 RELEASE DATED NOV 76 UPDATED JULY 1979  
 ERROR CORR - P102203  
 MODIFICATION - 008115053

NOTE - ASTRISK (\*) AT LEFT OF CROSS-SECTION NUMBER INDICATES MESSAGE IN SUMMARY OF ERRORS LIST

SPILLWAY RATING CURVE  
 SUMMARY PRINTOUT

SECTNO	DEPTH	AREA	TOPWID	VCH	HY	Q	LEG	10KFS	KONNCH
1-000	1.55	1655	1459	6.01	0.56	100.00	575.89	241.54	40.00
1-000	2.02	2782	1787	7.19	.80	200.00	576.82	218.61	40.00
1-000	2.55	3740	1908	7.94	.90	300.00	577.53	206.62	40.00
1-000	3.03	4718	2130	8.48	1.12	400.00	578.13	197.62	40.00
1-000	3.42	5607	2282	8.92	1.23	500.00	578.65	191.25	40.00
1-000	4.08	7204	2400	9.47	1.47	700.00	579.55	186.37	40.00
1-000	4.56	7907	2500	10.14	1.54	800.00	479.95	183.17	40.00
1-000	4.85	9131	2500	10.75	1.86	1000.00	380.71	185.17	40.00
1-000	5.77	11436	2500	12.24	2.33	1400.00	502.10	186.82	40.00
2-000	1.93	2428	1646	4.97	.26	100.00	579.09	77.84	40.00
2-000	2.53	3923	1906	5.10	.40	200.00	640.03	82.93	40.00
2-000	3.23	5184	2211	6.19	.58	300.00	608.75	85.87	40.00
2-000	3.72	6321	2396	6.33	.62	400.00	591.54	87.94	40.00
2-000	4.14	7349	2500	6.80	.72	500.00	531.60	89.48	40.00
2-000	4.73	9121	2500	7.67	.91	700.00	582.76	91.82	40.00
2-000	5.17	9922	2500	8.06	1.01	800.00	543.18	92.77	40.00
2-000	5.81	11572	2500	8.68	1.17	1000.00	583.98	93.23	40.00
2-000	6.87	14416	2600	9.71	1.44	1400.00	585.93	93.93	40.00

SUMMARY OF ERRORS

CAUTION SECTNO: 1-000 PROFILE: 1 CRITICAL DEPTH ASSUMED  
 CAUTION SECTNO: 1-000 PROFILE: 2 CRITICAL DEPTH ASSUMED  
 CAUTION SECTNO: 1-000 PROFILE: 3 CRITICAL DEPTH ASSUMED  
 CAUTION SECTNO: 1-000 PROFILE: 4 CRITICAL DEPTH ASSUMED  
 CAUTION SECTNO: 1-000 PROFILE: 5 CRITICAL DEPTH ASSUMED  
 CAUTION SECTNO: 1-000 PROFILE: 6 CRITICAL DEPTH ASSUMED  
 CAUTION SECTNO: 1-000 PROFILE: 7 CRITICAL DEPTH ASSUMED  
 CAUTION SECTNO: 1-000 PROFILE: 8 CRITICAL DEPTH ASSUMED  
 CAUTION SECTNO: 1-000 PROFILE: 9 CRITICAL DEPTH ASSUMED

# PRC ENGINEERING CONSULTANTS, INC.

DAM SAFETY INSPECTION - MISSOURI SHEET NO. 1 OF 1

DAM NAME: Smith Lake Dam / ID NO.: 11124 JOB NO.

RESERVOIR ELEVATION - AREA DATA BY DATE 7/10

ELEV. (M.S.L.) (Ft.)	RESERVOIR SURFACE AREA (Acres)	REMARKS
555	0	Estimated Streambed
570	2.5	Interpolated
577	3.5	Spillway Crest
580	4.0	Measured on USGS Map
581	4.5	Top of Dam (Assumed elevation)
590	5.5	Interpolated
600	7.5	Measured on USGS Map

DAM SAFETY INSPECTION / MISSOURI

SHEET NO. 1 OF 1

DAM NAME: SMITH LAKE DAM

JOB NO. 1263

UNIT HYDROGRAPH PARAMETERS

BY D.C. DATE 7/15/80

- 1) DRAINAGE AREA,  $A = .071$  sq. mi = (45 acres)
- 2) LENGTH OF STREAM,  $L = (.8 \text{ " } \times 2000 \text{ ' } = 1600 \text{ ' } ) = .303$  mi.
- 3) ELEVATION AT DRAINAGE DIVIDE ALONG THE LONGEST STREAM,  
 $H_1 = 761'$
- 4) ELEVATION OF RESERVOIR AT SPILLWAY CREST,  $H_2 = 577'$
- 5) ELEVATION OF CHANNEL BED AT  $0.85L$ ,  $E_{85} = 680'$
- 6) ELEVATION OF CHANNEL BED AT  $0.10L$ ,  $E_{10} = 578'$
- 7) AVERAGE SLOPE OF THE CHANNEL,  $S_{AVG} = (E_{85} - E_{10}) / 0.75L = .085$
- 8) TIME OF CONCENTRATION:

A) BY KIRPICH'S EQUATION,

$$t_c = [(11.9 \times L^3) / (H_1 - H_2)]^{0.385} = \left( \frac{11.9 \times 303^3}{761 - 577} \right)^{0.385} = .088 \text{ hr}$$

B) BY VELOCITY ESTIMATE,

$$\text{SLOPE} = 7.5\% \Rightarrow \text{AVG. VELOCITY} = 5 \text{ fps}$$

$$t_c = L / V = .089 \text{ hr}$$

USE  $t_c = .089$  hr.9) LAG TIME,  $t_l = 0.6 t_c = .0528$  hr.10) UNIT DURATION,  $D \leq t_l / 3 = .0176$  hr.

&lt; 0.083 hr.

USE  $D = .083$  hr.11) TIME TO PEAK,  $T_p = D/2 + t_l = .095$  hr.

12) PEAK DISCHARGE,

$$q_p = (484 \times A) / T_p = 365 \text{ cfs}$$

DAM SAFETY INSPECTION

SHEET NO. 1 OF 1

SMITH LAKE DAM

JOB NO. 1263

STARTING WSEL FOR PMF ROUTING

BY D.C DATE 7/17/80

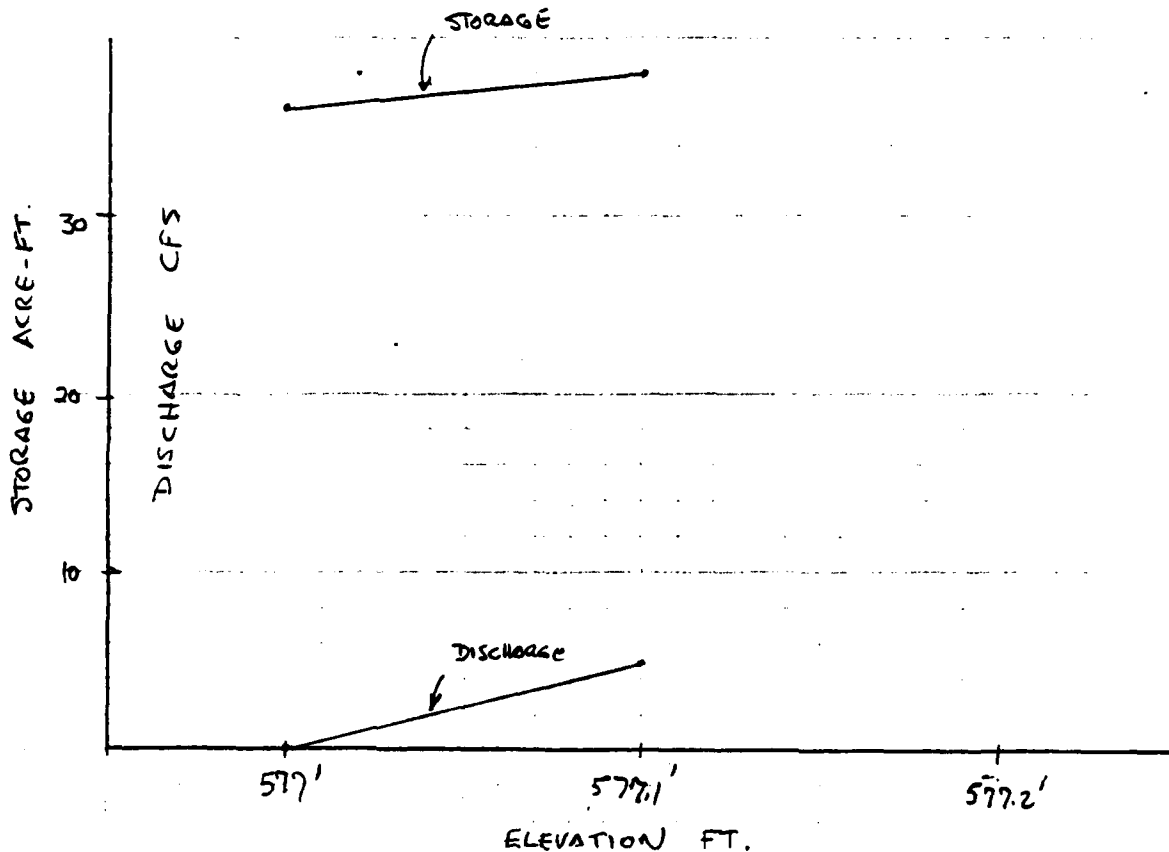

I. WSEL = 577.1 at end of 1/2 PMF Routing

From WSEL → 577.1 to 577'

$$\Delta S = 34 - 33 = 1 \text{ ac-ft}$$

$$Q = 2.5 \text{ cfs}$$

$$t = 1 \text{ ac-ft} \times \frac{43560 \text{ ft}^2}{\text{ac}} \times \frac{1.5}{2.5 \text{ ft}^3} \times \frac{1 \text{ day}}{86400 \text{ s}} = 0.2 \text{ days} < 3 \text{ days}$$

∴ Since water level returns to spillway crest in less than 3 days, start PMF routing when W.L. is at spillway crest.

\*\*\*\*\*  
 FLOOD HYDROGRAPH PACKAGE (HEC-1)  
 DAM SAFETY VERSION JULY 1978  
 LAST MODIFICATION 26 FEB 79  
 \*\*\*\*\*

1	A1	DAM SAFETY INSPECTION MISSOURI							
2	A2	SMITH LAKE DAM (MO 11124)							
3	A3	PMF AND 50 PERCENT PMF							
4	B	300	0	0	0	0	0	0	0
5	B1	5							
6	J	1	2	1					
7	J1	1	.5						
8	K	0 M011124							1
9	K1	INPUT PRECIPITATION INDEX, RATIOS, AND UNIT HYDROGRAPH PARAMETERS							
10	M	1	.071		.071	1			J
11	P	24.5	100	120	130				
12	T								-1 -89
13	M2	.0528							
14	X								
15	K	1 M011124							1
16	K1	ROUTIE HYDROGRAPH THROUGH SMITH LAKE DAM (MO 11124)							
17	Y								
18	Y1	1							-577 -1
19	Y4	577	579.09	580.03	581.34	581.86	582.76	583.18	583.98
20	Y5	0	100	200	300	519	965	2126	4746
21	SA	0	2.5	3.5	4	4.5	5.5	7.5	9459
22	SE	555	570	577	580	581	590	600	
23	IS	577							
24	SD	581							
25	K	99							



300000

MOBDA HRYM PERIOD NAT. RATE LOSS ENDGR-FEELOR FLOW MB.DA HR.MN PERIOD RAIN EXCS LOSS COMP

MOBDA	HRYM	PERIOD	NAT.	RATE	LOSS	ENDGR-FEELOR FLOW	MB.DA	HR.MN	PERIOD	RAIN	EXCS	LOSS	COMP
1.01	0.05	1	0	0.00	0.00	0	1.01	13.12	14	12	12	12	12
1.01	0.10	2	0	0.00	0.00	0	1.01	12.40	15	20	20	20	20
1.01	0.15	3	0	0.00	0.00	0	1.01	12.45	16	20	20	20	20
1.01	0.20	4	0	0.00	0.00	0	1.01	12.50	17	20	20	20	20
1.01	0.25	5	0	0.00	0.00	0	1.01	12.55	18	20	20	20	20
1.01	0.30	6	0	0.00	0.00	0	1.01	13.00	19	20	20	20	20
1.01	0.35	7	0	0.00	0.00	0	1.01	13.05	20	22	22	22	22
1.01	0.40	8	0	0.00	0.00	0	1.01	13.10	21	25	25	25	25
1.01	0.45	9	0	0.00	0.00	0	1.01	13.15	22	25	25	25	25
1.01	0.50	10	0	0.00	0.00	0	1.01	13.20	23	25	25	25	25
1.01	0.55	11	0	0.00	0.00	0	1.01	13.25	24	25	25	25	25
1.01	1.00	12	0	0.00	0.00	0	1.01	13.30	25	24	24	24	24
1.01	1.05	13	0	0.00	0.00	0	1.01	13.35	26	25	25	25	25
1.01	1.10	14	0	0.00	0.00	0	1.01	13.40	27	25	25	25	25
1.01	1.15	15	0	0.00	0.00	0	1.01	13.45	28	25	25	25	25
1.01	1.20	16	0	0.00	0.00	0	1.01	13.50	29	25	25	25	25
1.01	1.25	17	0	0.00	0.00	0	1.01	13.55	30	25	25	25	25
1.01	1.30	18	0	0.00	0.00	0	1.01	14.00	31	25	25	25	25
1.01	1.35	19	0	0.00	0.00	0	1.01	14.05	32	31	31	31	31
1.01	1.40	20	0	0.00	0.00	0	1.01	14.10	33	31	31	31	31
1.01	1.45	21	0	0.00	0.00	0	1.01	14.15	34	31	31	31	31
1.01	1.50	22	0	0.00	0.00	0	1.01	14.20	35	31	31	31	31
1.01	1.55	23	0	0.00	0.00	0	1.01	14.25	36	31	31	31	31
1.01	2.00	24	0	0.00	0.00	0	1.01	14.30	37	31	31	31	31
1.01	2.05	25	0	0.00	0.00	0	1.01	14.35	38	31	31	31	31
1.01	2.10	26	0	0.00	0.00	0	1.01	14.40	39	31	31	31	31
1.01	2.15	27	0	0.00	0.00	0	1.01	14.45	40	31	31	31	31
1.01	2.20	28	0	0.00	0.00	0	1.01	14.50	41	31	31	31	31
1.01	2.25	29	0	0.00	0.00	0	1.01	14.55	42	31	31	31	31
1.01	2.30	30	0	0.00	0.00	0	1.01	15.00	43	31	31	31	31
1.01	2.35	31	0	0.00	0.00	0	1.01	15.05	44	31	31	31	31
1.01	2.40	32	0	0.00	0.00	0	1.01	15.10	45	31	31	31	31
1.01	2.45	33	0	0.00	0.00	0	1.01	15.15	46	31	31	31	31
1.01	2.50	34	0	0.00	0.00	0	1.01	15.20	47	31	31	31	31
1.01	2.55	35	0	0.00	0.00	0	1.01	15.25	48	31	31	31	31
1.01	3.00	36	0	0.00	0.00	0	1.01	15.30	49	31	31	31	31
1.01	3.05	37	0	0.00	0.00	0	1.01	15.35	50	31	31	31	31
1.01	3.10	38	0	0.00	0.00	0	1.01	15.40	51	31	31	31	31
1.01	3.15	39	0	0.00	0.00	0	1.01	15.45	52	31	31	31	31
1.01	3.20	40	0	0.00	0.00	0	1.01	15.50	53	31	31	31	31
1.01	3.25	41	0	0.00	0.00	0	1.01	15.55	54	31	31	31	31
1.01	3.30	42	0	0.00	0.00	0	1.01	16.00	55	31	31	31	31
1.01	3.35	43	0	0.00	0.00	0	1.01	16.05	56	31	31	31	31
1.01	3.40	44	0	0.00	0.00	0	1.01	16.10	57	31	31	31	31
1.01	3.45	45	0	0.00	0.00	0	1.01	16.15	58	31	31	31	31
1.01	3.50	46	0	0.00	0.00	0	1.01	16.20	59	31	31	31	31
1.01	3.55	47	0	0.00	0.00	0	1.01	16.25	60	31	31	31	31
1.01	4.00	48	0	0.00	0.00	0	1.01	16.30	61	31	31	31	31
1.01	4.05	49	0	0.00	0.00	0	1.01	16.35	62	31	31	31	31
1.01	4.10	50	0	0.00	0.00	0	1.01	16.40	63	31	31	31	31
1.01	4.15	51	0	0.00	0.00	0	1.01	16.45	64	31	31	31	31
1.01	4.20	52	0	0.00	0.00	0	1.01	16.50	65	31	31	31	31
1.01	4.25	53	0	0.00	0.00	0	1.01	16.55	66	31	31	31	31
1.01	4.30	54	0	0.00	0.00	0	1.01	16.55	67	31	31	31	31
1.01	4.35	55	0	0.00	0.00	0	1.01	16.55	68	31	31	31	31
1.01	4.40	56	0	0.00	0.00	0	1.01	16.55	69	31	31	31	31
1.01	4.45	57	0	0.00	0.00	0	1.01	16.55	70	31	31	31	31
1.01	4.50	58	0	0.00	0.00	0	1.01	16.55	71	31	31	31	31
1.01	4.55	59	0	0.00	0.00	0	1.01	16.55	72	31	31	31	31
1.01	4.60	60	0	0.00	0.00	0	1.01	16.55	73	31	31	31	31
1.01	4.65	61	0	0.00	0.00	0	1.01	16.55	74	31	31	31	31
1.01	4.70	62	0	0.00	0.00	0	1.01	16.55	75	31	31	31	31
1.01	4.75	63	0	0.00	0.00	0	1.01	16.55	76	31	31	31	31
1.01	4.80	64	0	0.00	0.00	0	1.01	16.55	77	31	31	31	31
1.01	4.85	65	0	0.00	0.00	0	1.01	16.55	78	31	31	31	31
1.01	4.90	66	0	0.00	0.00	0	1.01	16.55	79	31	31	31	31
1.01	4.95	67	0	0.00	0.00	0	1.01	16.55	80	31	31	31	31
1.01	5.00	68	0	0.00	0.00	0	1.01	16.55	81	31	31	31	31
1.01	5.05	69	0	0.00	0.00	0	1.01	16.55	82	31	31	31	31
1.01	5.10	70	0	0.00	0.00	0	1.01	16.55	83	31	31	31	31
1.01	5.15	71	0	0.00	0.00	0	1.01	16.55	84	31	31	31	31
1.01	5.20	72	0	0.00	0.00	0	1.01	16.55	85	31	31	31	31
1.01	5.25	73	0	0.00	0.00	0	1.01	16.55	86	31	31	31	31
1.01	5.30	74	0	0.00	0.00	0	1.01	16.55	87	31	31	31	31
1.01	5.35	75	0	0.00	0.00	0	1.01	16.55	88	31	31	31	31
1.01	5.40	76	0	0.00	0.00	0	1.01	16.55	89	31	31	31	31
1.01	5.45	77	0	0.00	0.00	0	1.01	16.55	90	31	31	31	31
1.01	5.50	78	0	0.00	0.00	0	1.01	16.55	91	31	31	31	31
1.01	5.55	79	0	0.00	0.00	0	1.01	16.55	92	31	31	31	31
1.01	5.60	80	0	0.00	0.00	0	1.01	16.55	93	31	31	31	31
1.01	5.65	81	0	0.00	0.00	0	1.01	16.55	94	31	31	31	31
1.01	5.70	82	0	0.00	0.00	0	1.01	16.55	95	31	31	31	31
1.01	5.75	83	0	0.00	0.00	0	1.01	16.55	96	31	31	31	31
1.01	5.80	84	0	0.00	0.00	0	1.01	16.55	97	31	31	31	31
1.01	5.85	85	0	0.00	0.00	0	1.01	16.55	98	31	31	31	31
1.01	5.90	86	0	0.00	0.00	0	1.01	16.55	99	31	31	31	31
1.01	5.95	87	0	0.00	0.00	0	1.01	16.55	100	31	31	31	31
1.01	6.00	88	0	0.00	0.00	0	1.01	16.55	101	31	31	31	31
1.01	6.05	89	0	0.00	0.00	0	1.01	16.55	102	31	31	31	31
1.01	6.10	90	0	0.00	0.00	0	1.01	16.55	103	31	31	31	31
1.01	6.15	91	0	0.00	0.00	0	1.01	16.55	104	31	31	31	31
1.01	6.20	92	0	0.00	0.00	0	1.01	16.55	105	31	31	31	31
1.01	6.25	93	0	0.00	0.00	0	1.01	16.55	106	31	31	31	31
1.01	6.30	94	0	0.00	0.00	0	1.01	16.55	107	31	31	31	31
1.01	6.35	95	0	0.00	0.00	0	1.01	16.55	108	31	31	31	31
1.01	6.40	96	0	0.00	0.00	0	1.01	16.55	109	31	31	31	31
1.01	6.45	97	0	0.00	0.00	0	1.01	16.55	110	31	31	31	31
1.01	6.50	98	0	0.00	0.00	0	1.01	16.55	111	31	31	31	31
1.01	6.55	99	0	0.00	0.00	0	1.01	16.55	112	31	31	31	31
1.01	6.60	100	0	0.00	0.00	0	1.01	16.55	113	31	31	31	31









PLAN FLOW AND STORAGE (END OF PERIOD) SUMMARY FOR MULTIPLE PLAN-RATIO ECONOMIC COMPUTATIONS  
 FLOWS IN CUBIC FEET PER SECOND (CUBIC METERS PER SECOND)  
 AREA IN SQUARE FEET (SQUARE METERS)

OPERATION STATION AREA PLAN RATIO 1 RATIO 2 RATIO 3 RATIO 4 RATIO 5 RATIO 6 RATIO 7 RATIO 8 RATIO 9 RATIO 10 RATIO 11 RATIO 12 RATIO 13 RATIO 14 RATIO 15 RATIO 16 RATIO 17 RATIO 18 RATIO 19 RATIO 20 RATIO 21 RATIO 22 RATIO 23 RATIO 24 RATIO 25 RATIO 26 RATIO 27 RATIO 28 RATIO 29 RATIO 30 RATIO 31 RATIO 32 RATIO 33 RATIO 34 RATIO 35 RATIO 36 RATIO 37 RATIO 38 RATIO 39 RATIO 40 RATIO 41 RATIO 42 RATIO 43 RATIO 44 RATIO 45 RATIO 46 RATIO 47 RATIO 48 RATIO 49 RATIO 50

HYDROGRAPH AT 011124 1.00 11824 5916  
 0121 1.00 334771 154731  
 011124 1.07 3904 2434  
 0121 1.00 334771 154731

SUMMARY OF DAM SAFETY ANALYSIS

INITIAL VALUE 377.00  
 SPILLWAY CAPCY 571.00  
 TOP OF DAM 681.00

ELEVATION 35  
 STORAGE 33  
 OUTFLOW 64

RATIO OF PNE	MAXIMUM DEPTH OVER DAM	MAXIMUM STORAGE AC-FT	MAXIMUM CUTFLOW CFS	DURATION OVER TOP HOURS	TIME OF MAX OUTFLOW HOURS	TIME OF FAILURE HOURS
100	175	52	890	42	1515	800
150	8.00	96	843	440	1505	840

.....  
 FLOOD HYDROGRAPH PACKAGE (REV. 11)  
 JAGS-FCTY VERSION JULY 1978  
 LAST MODIFICATION 26 FEB 79  
 .....

RUN DATE: 06/08/80  
 TIME: 10:09:27

DAM SAFETY INSPECTION MISSOURI  
 SHILOH LAKE DAM (NO. 11184)  
 PERCENT PHS

JOB SPECIFICATION

NO	NHR	NMIN	JDAY	IHR	I MIN	MLTRC	IPLT	IPRT	ASTAN
300	0	5	0	0	0	0	0	-4	0
			JOPER	NMT	LROPT	TRACE			
			5	0	0	0			

MULTI-PLAN ANALYSES TO BE PERFORMED  
 MPLAN= 1 MHI0= 1 LATI0= 1

RTI0= 0.60 .65 .70 .75

..... SUB-AREA RUNOFF COMPUTATION .....

INPUT PRECIPITATION INDEX, RATIOS, AND UNIT HYDROGRAPH PARAMETERS

ESTAD	ICOMP	IICON	ITAPL	JPLY	JPRT	ENAME	ISTAGE	TAUTO
011124	0	0	0	0	1	0	0	0

HYDROGRAPH DATA

INTG6	JUN6	JAN6	SNAP	TRSDA	TRSPC	RATIO	ISNCY	ISANT	LOCAL
1	2	37	0.00	107	1.00	0.000	0	1	0

PRECIP DATA

PHS	R6	R12	R24	R48	R72	F96
0.00	24.00	120.00	150.00	0.00	0.00	0.00

LOSS DATA

LROPT	STRK4	DLFKH	RTIOL	CRAN	STRKS	RTI0K	STRTL	CNSIL	ALSMX	RTIMP
0	0.00	0.00	1.00	0.00	1.00	1.00	-1.00	-89.00	0.00	0.00

CURVE NO = 89.00 WLFNBS = 1.00 EFFECT CN = 09.00

UNIT HYDROGRAPH DATA

TC= 0.00 LAG= 0.00

RECESSION DATA

RTI0K= 1.00

NO.DA	HLIN	PERIOD	RAIN	EXCS	LOSS	COMP
0	0	0	0	0	0	0





SUMMARY OF DAM SAFETY ANALYSIS

PLAN 3 ..... INITIAL VALUE      SPILLWAY CREST      TOP OF DAM  
 ELEVATION      577.00      577.00      581.90  
 STORAGE      300      300      300  
 OUTFLOW      0      0      0

RATIO OF PPE	MAXIMUM RESERVOIR DEPTH	MAXIMUM STORAGE OVER DAM	MAXIMUM STORAGE	MAXIMUM OUTFLOW CFS	DURATION OVER TOP	TIME OF MAX OUTFLOW	TIME OF FAILURE
		FEET	ACRE-FT		HOURS	HOURS	HOURS
0.60	280.00	98	325	325	0.00	15.75	0.00
0.70	300.00	120	382	382	0.00	15.75	0.00
0.75	301.25	121	383	383	0.17	15.75	0.00
		124	391	391	0.28	15.75	0.00

**DATE**  
**ILME**