

AD-A105 015

PRC CONSOER TOWNSEND INC ST LOUIS MO  
NATIONAL DAM SAFETY PROGRAM. MOORES LAKE DAM (MO 11173), MISSOU--ETC(U)  
DEC 80 W G SHIFRIN

F/8 13/13

DACW43-8U-C-0094

NL

UNCLASSIFIED

100  
ALL  
1000-5

END  
DATE  
FILMED  
10-81  
DTIC

**LEVEL 1**

**1**  
BS

**MISSOURI - KANSAS CITY RIVER BASIN**

AD A105015

MOORES LAKE DAM  
BOONE COUNTY, MISSOURI  
MO. 11173

**DTIC**  
**ELECTE**  
**S** OCT 0 6 1981  
**E**

(11) Dec 88  
(15) DACW43-80-C-0094  
(9) Final rept.  
(10) Walter G. Shifrin

**PHASE I INSPECTION REPORT**

**6 NATIONAL DAM SAFETY PROGRAM.**

Moore Lake Dam (MO 11173),  
Missouri - Kansas City River Basin,  
Boone County, Missouri. Phase I Inspection  
Report.

**12** 99



**United States Army  
Corps of Engineers**  
... Serving the Army  
... Serving the Nation

**St. Louis District**

**DTIC FILE COPY**

PREPARED BY: U. S. ARMY ENGINEER DISTRICT, ST. LOUIS

FOR: STATE OF MISSOURI

This document has been approved  
for public release and sale; its  
distribution is unlimited.

DECEMBER 1980

412553  
81 10 2 172 *mt*

T  
BS

UNCLASSIFIED

SECURITY CLASSIFICATION OF THIS PAGE (When Data Entered)

REPORT DOCUMENTATION PAGE		READ INSTRUCTIONS BEFORE COMPLETING FORM
1. REPORT NUMBER	2. GOVT ACCESSION NO. <i>AD-A105 015</i>	3. RECIPIENT'S CATALOG NUMBER
4. TITLE (and Subtitle) Phase I Dam Inspection Report National Dam Safety Program Moores Lake Dam (MO 11173) Boone County, Missouri		5. TYPE OF REPORT & PERIOD COVERED Final Report
7. AUTHOR(s) Consoer, Townsend and Associates, Ltd.		6. PERFORMING ORG. REPORT NUMBER
9. PERFORMING ORGANIZATION NAME AND ADDRESS U.S. Army Engineer District, St. Louis Dam Inventory and Inspection Section, LMSED-PD 210 Tucker Blvd., North, St. Louis, Mo. 63101		8. CONTRACT OR GRANT NUMBER(s) DACW43-80-C-0094
11. CONTROLLING OFFICE NAME AND ADDRESS U.S. Army Engineer District, St. Louis Dam Inventory and Inspection Section, LMSED-PD 210 Tucker Blvd., North, St. Louis, Mo. 63101		10. PROGRAM ELEMENT, PROJECT, TASK AREA & WORK UNIT NUMBERS
14. MONITORING AGENCY NAME & ADDRESS (if different from Controlling Office)		12. REPORT DATE December 1980
		13. NUMBER OF PAGES Approximately 60
		15. SECURITY CLASS. (of this report) UNCLASSIFIED
		15a. DECLASSIFICATION/DOWNGRADING SCHEDULE
16. DISTRIBUTION STATEMENT (of this Report)  Approved for release; distribution unlimited.		
17. DISTRIBUTION STATEMENT (of the abstract entered in Block 20, if different from Report)		
18. SUPPLEMENTARY NOTES		
19. KEY WORDS (Continue on reverse side if necessary and identify by block number)  Dam Safety, Lake, Dam Inspection, Private Dams		
20. ABSTRACT (Continue on reverse side if necessary and identify by block number) This report was prepared under the National Program of Inspection of Non-Federal Dams. This report assesses the general condition of the dam with respect to safety, based on available data and on visual inspection, to determine if the dam poses hazards to human life or property.		

DD FORM 1 JAN 72 1473

EDITION OF 1 NOV 65 IS OBSOLETE

UNCLASSIFIED

SECURITY CLASSIFICATION OF THIS PAGE (When Data Entered)

## INSTRUCTIONS FOR PREPARATION OF REPORT DOCUMENTATION PAGE

**RESPONSIBILITY.** The controlling DoD office will be responsible for completion of the Report Documentation Page, DD Form 1473, in all technical reports prepared by or for DoD organizations.

**CLASSIFICATION.** Since this Report Documentation Page, DD Form 1473, is used in preparing announcements, bibliographies, and data banks, it should be unclassified if possible. If a classification is required, identify the classified items on the page by the appropriate symbol.

### COMPLETION GUIDE

General. Make Blocks 1, 4, 5, 6, 7, 11, 13, 15, and 16 agree with the corresponding information on the report cover. Leave Blocks 2 and 3 blank.

**Block 1.** Report Number. Enter the unique alphanumeric report number shown on the cover.

**Block 2.** Government Accession No. Leave Blank. This space is for use by the Defense Documentation Center.

**Block 3.** Recipient's Catalog Number. Leave blank. This space is for the use of the report recipient to assist in future retrieval of the document.

**Block 4.** Title and Subtitle. Enter the title in all capital letters exactly as it appears on the publication. Titles should be unclassified whenever possible. Write out the English equivalent for Greek letters and mathematical symbols in the title (see "Abstracting Scientific and Technical Reports of Defense-sponsored RDT/E," AD-667 000). If the report has a subtitle, this subtitle should follow the main title, be separated by a comma or semicolon if appropriate, and be initially capitalized. If a publication has a title in a foreign language, translate the title into English and follow the English translation with the title in the original language. Make every effort to simplify the title before publication.

**Block 5.** Type of Report and Period Covered. Indicate here whether report is interim, final, etc., and, if applicable, inclusive dates of period covered, such as the life of a contract covered in a final contractor report.

**Block 6.** Performing Organization Report Number. Only numbers other than the official report number shown in Block 1, such as series numbers for in-house reports or a contractor/grantee number assigned by him, will be placed in this space. If no such numbers are used, leave this space blank.

**Block 7.** Author(s). Include corresponding information from the report cover. Give the name(s) of the author(s) in conventional order (for example, John R. Doe or, if author prefers, J. Robert Doe). In addition, list the affiliation of an author if it differs from that of the performing organization.

**Block 8.** Contract or Grant Number(s). For a contractor or grantee report, enter the complete contract or grant number(s) under which the work reported was accomplished. Leave blank in in-house reports.

**Block 9.** Performing Organization Name and Address. For in-house reports enter the name and address, including office symbol, of the performing activity. For contractor or grantee reports enter the name and address of the contractor or grantee who prepared the report and identify the appropriate corporate division, school, laboratory, etc., of the author. List city, state, and ZIP Code.

**Block 10.** Program Element, Project, Task Area, and Work Unit Numbers. Enter here the number code from the applicable Department of Defense form, such as the DD Form 1498, "Research and Technology Work Unit Summary" or the DD Form 1634, "Research and Development Planning Summary," which identifies the program element, project, task area, and work unit or equivalent under which the work was authorized.

**Block 11.** Controlling Office Name and Address. Enter the full, official name and address, including office symbol, of the controlling office. (Equates to funding/sponsoring agency. For definition see DoD Directive 5200.20, "Distribution Statements on Technical Documents.")

**Block 12.** Report Date. Enter here the day, month, and year or month and year as shown on the cover.

**Block 13.** Number of Pages. Enter the total number of pages.

**Block 14.** Monitoring Agency Name and Address (if different from Controlling Office). For use when the controlling or funding office does not directly administer a project, contract, or grant, but delegates the administrative responsibility to another organization.

**Blocks 15 & 15a.** Security Classification of the Report: Declassification/Downgrading Schedule of the Report. Enter in 15 the highest classification of the report. If appropriate, enter in 15a the declassification/downgrading schedule of the report, using the abbreviations for declassification/downgrading schedules listed in paragraph 4-207 of DoD 5200.1-R.

**Block 16.** Distribution Statement of the Report. Insert here the applicable distribution statement of the report from DoD Directive 5200.20, "Distribution Statements on Technical Documents."

**Block 17.** Distribution Statement (of the abstract entered in Block 20, if different from the distribution statement of the report). Insert here the applicable distribution statement of the abstract from DoD Directive 5200.20, "Distribution Statements on Technical Documents."

**Block 18.** Supplementary Notes. Enter information not included elsewhere but useful, such as: Prepared in cooperation with . . . Translation of (or by) . . . Presented at conference of . . . To be published in . . .

**Block 19.** Key Words. Select terms or short phrases that identify the principal subjects covered in the report, and are sufficiently specific and precise to be used as index entries for cataloging, conforming to standard terminology. The DoD "Thesaurus of Engineering and Scientific Terms" (TEST), AD-672 000, can be helpful.

**Block 20.** Abstract. The abstract should be a brief (not to exceed 200 words) factual summary of the most significant information contained in the report. If possible, the abstract of a classified report should be unclassified and the abstract to an unclassified report should consist of publicly-releasable information. If the report contains a significant bibliography or literature survey, mention it here. For information on preparing abstracts see "Abstracting Scientific and Technical Reports of Defense-Sponsored RDT&E," AD-667 000



REPLY TO  
ATTENTION OF

**DEPARTMENT OF THE ARMY**  
ST. LOUIS DISTRICT, CORPS OF ENGINEERS  
210 TUCKER BOULEVARD, NORTH  
ST. LOUIS, MISSOURI 63101

Accession For	
NTIS GRA&I	<input checked="" type="checkbox"/>
DTIC TAB	<input type="checkbox"/>
Unannounced	<input type="checkbox"/>
Justification	<input type="checkbox"/>
By _____	
Distribution/ _____	
Availability Codes	
Dist	Avail and/or Special
A	

SUBJECT: Moores Lake Dam (MO 11173)

This report presents the results of field inspection and evaluation of the Moores Lake Dam . It was prepared under the National Program of Inspection of Non-Federal Dams .

SUBMITTED BY:                     **SIGNED**                      
Chief, Engineering Division

                    **20 JAN 1981**                      
Date

APPROVED BY:                     **SIGNED**                      
Colonel, CE, District Engineer

                    **21 JAN 1981**                      
Date

MOORES LAKE DAM  
BOONE COUNTY, MISSOURI

MISSOURI INVENTORY NO. 11173

PHASE I INSPECTION REPORT  
NATIONAL DAM SAFETY PROGRAM

PREPARED BY  
CONSOER, TOWNSEND AND ASSOCIATES, LTD.  
ST. LOUIS, MISSOURI  
AND  
PRC ENGINEERING CONSULTANTS, INC.  
ENGLEWOOD, COLORADO  
A JOINT VENTURE

UNDER DIRECTION OF  
ST. LOUIS DISTRICT, CORPS OF ENGINEERS  
FOR  
GOVERNOR OF MISSOURI

DECEMBER 1980

PHASE I INSPECTION REPORT  
NATIONAL DAM SAFETY PROGRAM

Name of Dam: Moores Lake Dam, Missouri Inv. No. 11173  
State Located: Missouri  
County Located: Boone  
Stream: An unnamed tributary of Bear Creek  
Date of Inspection: July 11, 1980

Assessment of General Condition

Moores Lake Dam was inspected by the engineering firms of Consoer, Townsend and Associates, Ltd. of St. Louis; Missouri and PRC Engineering Consultants, Inc. of Englewood, Colorado (A Joint Venture) according to the U. S. Army Corps of Engineers' "Recommended Guidelines for Safety Inspection of Dams" and additional guidelines furnished by the St. Louis District of the Corps of Engineers. Based upon the criteria in the guidelines, the dam is in the high hazard potential classification, which means that loss of life and appreciable property loss could occur in the event of failure of the dam. Within the estimated damage zone of two miles downstream of the dam are the crossing of Interstate Highway I-70 immediately downstream of the dam, three commercial buildings, one trailer, one gas station and two large buildings which may be subjected to flooding, with possible damage and/or destruction, and possible loss of life. Moores Lake Dam is in the small size classification since it is less than 40 feet and more than 25 feet high, and impounds 45 acre-feet of water.

The inspection and evaluation by the consultant's inspection team indicate that the spillway of Moores Lake Dam does not meet the

criteria set forth in the guidelines for a dam having the above size and hazard potential. Moores Lake Dam being a small size dam with a high hazard potential is required by the guidelines to pass from one-half of the Probable Maximum Flood to the Probable Maximum Flood without overtopping. Considering an Interstate Highway (I-70), located immediately below the dam, and several other commercial buildings along the banks of the same stream within two miles downstream of the dam, the PMF is considered the appropriate spillway design flood for Moores Lake Dam. The Probable Maximum Flood is defined as the flood discharge that may be expected from the most severe combination of critical meteorological and hydrologic conditions that are reasonably possible in the region. It was determined that the reservoir/spillway system can accommodate approximately 50 percent of the Probable Maximum Flood without overtopping the dam. The evaluation also indicates that the reservoir/spillway system can accommodate the one-percent chance flood (100-year flood) without overtopping.

Other deficiencies noted by the inspection team were: the sloughing on the downstream slope, undermining of the downstream toe adjacent to the low level outlet, erosion due to wave action on the upstream slope, trees and bushes on the embankment, voids and rodent holes in the embankment, a need for periodic inspection by a qualified engineer and a lack of maintenance schedule. The lack of seepage and stability analyses on record is also a deficiency that should be corrected.

It is recommended that the owner take action to correct or control the deficiencies described above.



Walter G. Shifrin, P.E.



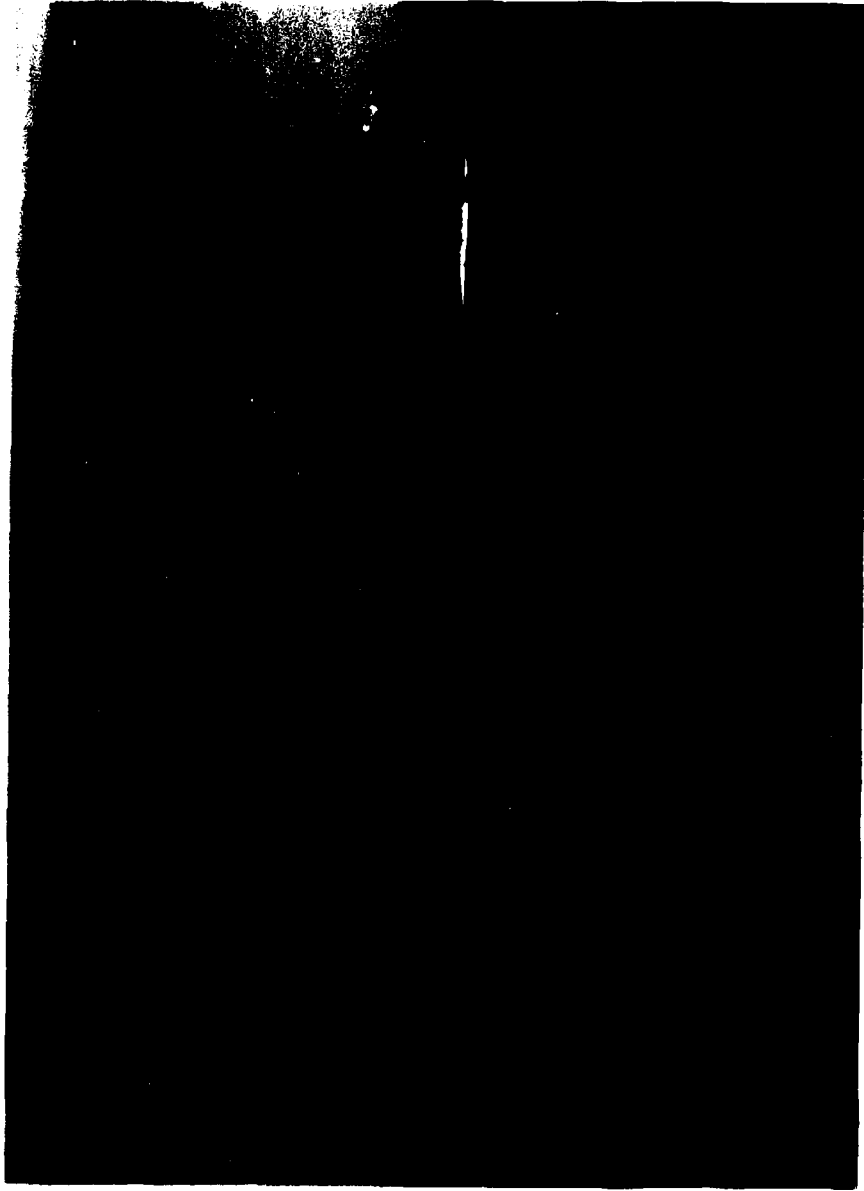

Overview of Moores Lake Dam

NATIONAL DAM SAFETY PROGRAM

MOORES LAKE DAM, I.D. No. 11173

TABLE OF CONTENTS

<u>Sect. No.</u>	<u>Title</u>	<u>Page</u>
SECTION 1	PROJECT INFORMATION . . . . .	1
	1.1 General . . . . .	1
	1.2 Description of Project . . . . .	2
	1.3 Pertinent Data . . . . .	7
SECTION 2	ENGINEERING DATA . . . . .	10
	2.1 Design . . . . .	10
	2.2 Construction . . . . .	10
	2.3 Operation . . . . .	10
	2.4 Evaluation . . . . .	10
SECTION 3	VISUAL INSPECTION . . . . .	12
	3.1 Findings . . . . .	12
	3.2 Evaluation . . . . .	18

TABLE OF CONTENTS

(Continued)

<u>Sect. No.</u>	<u>Title</u>	<u>Page</u>
SECTION 4	OPERATION PROCEDURES . . . . .	20
	4.1 Procedures . . . . .	20
	4.2 Maintenance of Dam . . . . .	20
	4.3 Maintenance of Operating Facilities . . . . .	20
	4.4 Description of Any Warning System in Effect . . . . .	21
	4.5 Evaluation . . . . .	21
SECTION 5	HYDRAULIC/HYDROLOGIC . . . . .	22
	5.1 Evaluation of Features . . . . .	22
SECTION 6	STRUCTURAL STABILITY. . . . .	24
	6.1 Evaluation of Structural Stability. . . . .	24
SECTION 7	ASSESSMENT/REMEDIAL MEASURES. . . . .	26
	7.1 Dam Assessment . . . . .	26
	7.2 Remedial Measures. . . . .	28

TABLE OF CONTENTS

(Continued)

LIST OF PLATES

	<u>Plate No.</u>
LOCATION MAP . . . . .	1
DRAINAGE BASIN AND DOWNSTREAM	
HAZARD ZONE . . . . .	1A
PLAN AND ELEVATION OF DAM . . . . .	2
SECTIONS OF EMBANKMENT . . . . .	3
GEOLOGIC MAP . . . . .	4-5

APPENDICES

APPENDIX A	-	PHOTOGRAPHS
APPENDIX B	-	HYDROLOGIC AND HYDRAULIC COMPUTATIONS

PHASE I INSPECTION REPORT  
NATIONAL DAM SAFETY PROGRAM

MOORES LAKE DAM, Missouri Inv. No. 11173

SECTION 1: PROJECT INFORMATION

1.1 General

a. Authority

The Dam Inspection Act, Public Law 92-367 of August, 1972, authorizes the Secretary of the Army, through the Corps of Engineers, to initiate a national program of dam inspections. Inspection for Moores Lake Dam was carried out under Contract DACW 43-80-C-0094 between the Department of the Army, St. Louis District, Corps of Engineers, and the engineering firms of Consoer, Townsend & Associates, Ltd., and PRC Engineering Consultants, Inc. (A Joint Venture), of St. Louis, Missouri.

b. Purpose of Inspection

The visual inspection of Moores Lake Dam was made on July 11, 1980. The purpose of the inspection was to make a general assessment as to the structural integrity and operational adequacy of the dam embankment and its appurtenant structures.

c. Scope of Report

This report summarizes available pertinent data relating to the project, presents a summary of visual observations made during the field inspection, presents an assessment of hydrologic and hydraulic conditions at the site and of the structural adequacy

of the various project features and assesses the general condition of the dam with respect to safety.

Subsurface investigations, laboratory testing and detailed analyses were not within the scope of this study. No warranty as to the absolute safety of the project features is implied by the conclusions presented in this report.

It should be noted that in this report reference to left or right abutments is viewed as looking downstream. Where left abutment or left side of the dam is used in this report, this also refers to the south abutment or side, and right abutment or right side of the dam to the east abutment or side.

d. Evaluation Criteria

The inspection and evaluation of the dam is performed in accordance with the U.S. Army Corps of Engineers' "Recommended Guidelines for Safety Inspection of Dams" and additional guidelines furnished by the St. Louis District office of the Corps of Engineers for Phase I Dam Inspection.

1.2 Description of the Project

a. Description of Dam and Appurtenances

It should be noted that neither design drawings nor "as-built" drawings were available for the dam or appurtenant structures. The following description is based exclusively upon observations and measurements made during the visual inspection and conversations with Mr. Gary Anderson, the owner's representative.

The dam embankment is an earthfill structure with variable section dimensions along its crest length. A plan and elevation of the dam are shown on Plate 2 and Photos 1 through 4 show views of the dam. The axis of dam is approximately a quarter circle

in shape and measures 752 feet long. The top width varies from 30 feet at the left abutment to approximately 90 feet at the midpoint of the dam and back to about 20 feet at the right abutment. The top of dam elevation varies non-uniformly (See Plate 2). The left and right sides of the dam were assumed to be at 773 feet above mean sea level (M.S.L.) with elevation increases of up to about 6.5 feet towards the middle of the embankment. The top of dam is crowned slightly and has many depressions. The maximum height of the embankment was measured to be 30 feet at approximately the mid-point along the axis of dam. The height of the dam at the left abutment near the two spillway pipes is 13 feet.

The average downstream slope of the embankment was measured as 1 vertical on 1.5 horizontal (1V on 1.5H). Where possible, the upstream slope was measured as 1V on 1.75H from the top of dam to the water surface. However, erosion, due to wave action, and dense vegetative cover made accurate measurements impossible. No riprap was placed on the upstream slope.

On the day of the inspection, there were three pipes at the damsite which allowed water to flow out of the reservoir. A 4-inch, an 8-inch, and a 10-inch diameter pipe have been provided.

The 4-inch pipe, according to Mr. Anderson, is located at the left abutment of the dam. The pipe was not located on the day of the inspection; however, the outlet structure for the pipe, according to Mr. Anderson, was a manhole on the downstream slope which was observed (see photo 8 and Plate 3). The outlet structure consists of a 2.25-foot wide diameter manhole with the bottom of the manhole located about 7 feet below the top of the manhole, which is also assumed to be the location of the outlet of the 4-inch diameter pipe (see Photo 10). The manhole is of brick and concrete mortar construction. The crest elevation of the pipe is unknown. According to Mr. Anderson, this pipe is controlled by a valve. Therefore, this pipe is considered to be a low level outlet type structure. Nevertheless, the valve was not located on the day of the inspection.

The 10-inch diameter pipe is a cast iron pipe laid through the embankment on a slope of 2 percent and is located at the left abutment of the dam. The inlet of the pipe can be seen in Photo 9 and the outlet end of the conduit is shown in Photo 8 to the left (in the photo) and just above the manhole described above. The crest elevation of the pipe is assumed to be at 769 feet above M.S.L. Flows through the pipe will discharge down the dam embankment.

The 8-inch diameter pipe is located at the southeast corner of the reservoir (for the actual location see Plate 2). Flows through the pipe discharge into a creek to the south of the power plant. The top of the pipe was about 4 inches below the reservoir water surface level on the day of the inspection. This pipe, according to Mr. Gary Anderson, is going to be plugged in October of 1980. On the day of the inspection, very little water was observed flowing through the pipe, which leads the inspection team to believe that the pipe is already partially plugged. Therefore, this pipe is assumed to be abandoned and was not used to determine the capacity of the spillway system. Therefore, there are essentially only one spillway and one low level outlet utilized at this damsite.

There are two structures at the damsite which discharge water into the reservoir. One of the structures consists of a 6-inch pipe through which a coal ash slurry from the power plant is pumped (see Photo 12). According to Mr. Anderson, between 200,000 to 300,000 gallons per day of the slurry are pumped into the reservoir. The second structure consists of a 10-inch cast iron pipe which is used to drain excess water from a cooling pond located adjacent to the cooling towers used for the power plant (see Photo 11). The location of the two structures are shown on Plate 2.

There were no other low level outlets or outlet works provided for this dam other than the 4-inch pipe mentioned above. Nevertheless, according to Mr. Anderson, in September of 1980, a recirculation system is going to be installed at the damsite in which water is going to be pumped from the reservoir to the power plant to be used in the coal ash slurry.

b. Location

Moores Lake Dam is located in Boone County in the State of Missouri, and crosses an unnamed tributary of Bear Creek. The damsite is at the northeast edge of the City of Columbia, Missouri. Moores Lake Dam location on the 7.5 minute series of the U.S. Geological Survey maps is found in Section 6 of Township 48 North, Range 12 West of the Columbia, Missouri Quadrangle Sheet.

c. Size Classification

The impoundment of Moores Lake Dam is 45 acre-feet, and the height is within the 25 to 40 foot range. Therefore, the size is determined to fall in the "small" category, according to the "Recommended Guidelines for Safety Inspection of Dams" by the U.S. Department of the Army, Office of the Chief Engineer.

d. Hazard Classification

The dam has been classified as having a "high" hazard potential in the National Inventory of Dams, on the basis that in the event of failure of the dam or its appurtenances, excessive damage could occur to downstream property, together with the possibility of the loss of life. Our findings concur with this classification. Within the estimated damage zone, extending two miles downstream of the dam, there are the crossing of Interstate Highway I-70 (immediately downstream of the dam), three commercial buildings, one trailer, a gas station and two large buildings.

e. Ownership

Moore's Lake Dam is owned by the City of Columbia, Missouri. The person responsible for operation and maintenance of the dam is Mr. Richard Malon, Director of Utilities, City of Columbia, Water & Light Department. His mailing address is as follows: P.O. Box N, Columbia, Missouri, 65201.

f. Purpose of Dam

According to Mr. Gary Anderson, an employee of the City Power Plant, the reservoir is used as a settling pond for the cinders and ash which are a by-product of the Municipal Power Plant. Originally, when the power plant was first put into operation, the lake was used as a source of cooling water for the plant, however, this is no longer the case. Mr. Anderson also mentioned that the dam was originally constructed to impound water for recreational use. This is evidenced by the fact that a recreational platform still exists at the eastern edge of the lake.

g. Design and Construction History

It is not known who was responsible for the original design or construction, however, Mr. Anderson believes that the dam was built around 1904. According to Mr. Anderson, in 1970 the height of the dam was increased by 1 or 2 feet, however, it is unknown why the dam height was increased. In June of 1980, the 10-inch pipe was added near the left abutment to act as a spillway, according to Mr. Anderson.

h. Normal Operational Procedures

Normal operational procedure at Moore's Lake Dam is to allow the reservoir to remain as full as possible with the water level being controlled by rainfall, evaporation, the elevation of the spillway crest, and the rate at which the coal ash slurry is pumped into the reservoir from the power plant.

1.3 Pertinent Data

a. Drainage Area (acres). . . . . 21

b. Discharge at Damsite

Estimated experienced maximum flood (cfs): . . . . . Unknown

Estimated ungated spillway capacity with  
reservoir at top of dam elevation (cfs): . . . . . 4

c. Elevation (Feet above M.S.L.)

Top of dam (minimum): . . . . . 773

Spillway crest\*: . . . . . 769

Normal Pool: . . . . . 769

Maximum Experienced Pool: . . . . . Unknown

Observed Pool: . . . . . 768.9

d. Reservoir

Length of pool with water surface  
at top of dam elevation (feet): . . . . . 600

e. Storage (Acre-Feet)

Top of dam (minimum): . . . . . 45

Spillway crest: . . . . . 15

Normal Pool: . . . . . 15

Maximum Experienced Pool: . . . . . Unknown

Observed Pool: . . . . . 15

f. Reservoir Surfaces (Acres)

Top of dam (minimum): . . . . . 8.5

Spillway crest: . . . . . 6.5

Normal Pool: . . . . . 6.5

Maximum Experienced Pool: . . . . . Unknown

Observed Pool: . . . . . 6.5

g. Dam

Type: . . . . .	Rolled, Earthfill
Length: . . . . .	752 feet
Structural Height: . . . . .	30 feet
Hydraulic Height**:. . . . .	30 feet
Top width: . . . . .	Varies, from 20 feet to 90 feet
Side slopes:	
Downstream . . . . .	1V on 1.5H
Upstream . . . . .	1V on 1.75H (Above water surface)
Zoning: . . . . .	Unknown
Impervious Core: . . . . .	Unknown
Cutoff: . . . . .	Unknown
Grout curtain: . . . . .	Unknown
Freeboard above normal reservoir level: . . . . .	4 feet (Minimum)
Volume: . . . . .	65,000 cu. yds. (Estimated)

h. Diversion and Regulating Tunnel. . None

i. Spillway

Type: . . . . .	Cast iron pipe, Uncontrolled
Length of crest: . . . . .	NA, (10-inch diameter pipe)
Crest Elevation (feet above MSL):. . . . .	769

j. Regulating Outlets

Type: . . . . .	4-inch diameter pipe
Location: . . . . .	Left abutment
Length: . . . . .	Unknown
Closure: . . . . .	Valve (Reportedly)
Maximum Capacity: . . . . .	Unknown

\* The elevation of the Spillway crest was assumed from the U.S.G.S. Columbia, Missouri Quadrangle topographic map. The elevations of other features of the dam were derived using this elevation and field measurements.

\*\* The hydraulic height of the dam is the vertical distance from the lowest point on the downstream toe to the top of dam or the maximum water surface if below the top of dam.

SECTION 2: ENGINEERING DATA

2.1 Design

No design data are available for the dam and the appurtenant structures.

2.2 Construction

No construction records or data are available for the dam or the appurtenant structures.

2.3 Operation

No operational records are available for Moores Lake Dam.

2.4 Evaluation

a. Availability

No design drawings, design computations, construction data or operation data are available. Also, no pertinent data were available for review of hydrology, spillway capacity, flood routing through the reservoir, slope stability, or foundation conditions. Seepage and stability analyses comparable to the requirements of the "Recommended Guidelines for Safety Inspection of Dams", were not available which is considered a deficiency.

b. Adequacy

The lack of engineering data did not allow a definitive review and evaluation. Therefore, the adequacy of this dam could not be assessed from the standpoint of reviewing and evaluating design, operation and construction data, but is based primarily on visual inspection, past performance history, and sound engineering judgement. Seepage and stability analyses comparable to the requirements of the "Recommended Guidelines for Safety Inspection of Dams" were not available, which is considered a deficiency. These seepage and stability analyses should be performed for appropriate loading conditions (including earthquake loads) and made a matter of record.

c. Validity

No engineering data were available which would allow a valid evaluation of original design concepts.

SECTION 3: VISUAL INSPECTION

3.1 Findings

a. General

A visual inspection of the Moores Lake Dam was made on July 11, 1980. The following persons were present during the inspection:

<u>Name</u>	<u>Affiliation</u>	<u>Disciplines</u>
Dr. M.A. Samad	PRC Engineering Consultants, Inc.	Project Engineer, Hydraulics and Hydrology
Mark Haynes, P.E.	PRC Engineering Consultants, Inc.	Civil and Mechanical
Razi Quraishi, R.P.G.	PRC Engineering Consultants, Inc.	Geology
Zoran Batchko	PRC Engineering Consultants, Inc.	Soils
Kevin J. Blume	Consoer, Townsend & Assoc., Ltd.	Civil and Structural
Gary Anderson	Employee of the City of Columbia, Water and Light Department	

Specific observations are discussed below.

b. Dam

The top of dam has a grass cover which adequately protects the embankment material from surface erosion (see Photo 2). The grass was mowed at the time of our inspection and, according to Mr. Gary Anderson, is mowed periodically. The irregularity in the top of dam is apparently due to the addition of on site spoils materials in the past and not due to settlements. It is unknown whether or not the dam has ever been overtopped; however, no evidence was observed indicating that the dam had been overtopped.

The upstream slope has no riprap protection and although the grass cover is dense, it has been eroded by wave action. Nearly vertical faces up to 3 feet high are exposed with a nearly horizontal bench at the water line. The material exposed on these faces is a low plasticity clay with a trace of gravels. The upstream slope also has medium-sized trees and large bushes growing on it.

The downstream embankment slope is, in general, not adequately protected by grass cover, especially the middle two-thirds of the embankment. Consequently, erosion due to surface runoff has been most severe. There are erosion channels up to 6 feet deep by 10 feet wide (see Photo 7). Large trees and bushes cover the downstream face (see Photo 4). The left and right sides of the downstream face are covered with tall grass and fewer and smaller trees are growing on the slope in these areas. There are several large rodent holes, up to 16-inches wide (see Photo 5), on the downstream face.

Where the new spillway pipe was installed through the left side of the embankment, there is no vegetative cover on the pipe backfill (see Photo 2). Near the low level outlet manhole, located at the left abutment, the downstream slope is covered with dumped debris such as boulders and concrete block fragments. The downstream toe has been undermined in this area by the water, which

has discharged through the low level outlet pipe (see Photo 8). The discharge channel for the spillway and low level outlet parallels the toe of the western embankment section. Approximately 60 feet to the right of the left abutment, there is a large scarp on the downstream face, which appears to be due to flows through the discharge channel (see Photo 6). The dish shaped, nearly vertical scarp extends from the toe to a point 10 feet above the toe, and is about 15 feet wide. The tall grass growing in the scarp and lack of slough material in the discharge channel indicates that the slough did not occur recently.

There is no evidence of seepage along the northern half of the embankment. Due to the flow of water through the discharge channel along the toe of the western portion of the dam, any seepage through the foundation was undetected. Nevertheless, there were no signs of seepage on the embankment face of the western portion of the dam.

No signs of past or present instability were observed on the embankment. However, several signs were observed on the embankment that could lead to a future instability. Both abutments are at approximately the same elevation as the top of dam. No instabilities, seepage, or erosion were observed on either abutment.

#### c. Project Geology and Soils

##### (1) Project Geology

The damsite is located on an unnamed tributary of Bear Creek in the Dissected Till Plains Section of the central Lowland Physiographic Province. Loess-mantled Kansas drift covers the surface of most of the Dissected Till Plains Section. The section is distinguished from the Young Drift Section to the north and from the Till Plains on the east by the stage it has reached in the post-glacial erosion cycle. Broadly generalized, this section is a nearly flat till plain submature to mature in its erosion cycle.

The topography at the damsite is rolling to hilly with U- to V-shaped valleys. Elevation of the ground surface ranges from 710 feet above M.S.L. at the damsite to 750 feet above M.S.L. approximately 0.25 miles from the damsite. The reservoir rim slopes are in the range of  $14^{\circ}$  to  $20^{\circ}$  from the horizontal and appear to be stable. The area near the damsite is covered with slope wash of glacial-fluvial deposits and loess.

The regional geology beneath the glacial outwash deposits in the damsite area as shown on the Geologic Map of Missouri (1979) (see Plate 6), consists of Pennsylvanian age undifferentiated age rocks, the Pennsylvanian Marmaton-Cherokee Group (cyclic deposits of shale, limestone, and sandstone), Mississippian age Burlington Limestone (cherty, grayish brown, sandy limestone), Devonian age rocks of the Sulphur Springs Group (Glen Park Limestone and Grassy Creek Shale), and Ordovician age rocks consisting of St. Peter Sandstone and Powell Dolomite.

No outcropping of bedrock was observed at the site. The predominant bedrock in the site vicinity underlying the glacial-fluvial deposits consists of the Cherokee Group and Burlington Limestone. Inlet and outlet areas of the unnamed tributary of Bear Creek contain Quaternary alluvium.

No faults have been identified in the vicinity of the damsite. The closest trace of a fault to the damsite is Fox Hollow fault nearly 15 miles south of the damsite. The Fox Hollow fault had its last movement in post-Mississippian time. Thus, the fault has no effect on the damsite.

Moores Lake Dam consists of homogeneous earthfill embankment, a spillway pipe located near the left end of the embankment and a low level outlet pipe located below the spillway pipe.

No boring logs or construction reports were available which would indicate foundation conditions encountered during the construction. Based on the visual inspection and conversations with Mr. Gary Anderson, the embankment probably rests on glacial-fluvial deposits. The spillway and outlet pipes rest on compacted embankment fill (mottled, yellowish brown to red, medium plastic, silty clay).

## (2) Project Soils

According to the "Soil Survey-Boone County Missouri" published by the Soil Conservation Service, the materials in the general area of the dam belong to the Gara Loam soil series in the deep loess and drift family. The soils were basically formed from erosion, leaching, and weathering of the glacial till and limestone. The permeability of these soils is moderate to slow. The Gara soil is generally quite susceptible to erosion. It is unknown whether the Gara soil type was used in the embankment, however, if it was used the potential of failure of the embankment would be increased due to erosion during overtopping.

Materials were removed from the upstream slope in two locations. One location was approximately 300 feet to the left of the right abutment contact and the other location was near the spillway outlet. Both samples were obtained from below the vegetative cover. Downstream slope material samples were readily obtained from the surface. Typically, the embankment material appeared to be a brown, moderately plastic, silty to sandy clay with traces of fine to medium gravel. Based upon the Unified Soil Classification System, the soil would probably be classified as a CL. This soil type generally has the following characteristics: it is semipervious to impervious with a coefficient of permeability less than 400 feet per year, has medium shear strength and an intermediate resistance to piping and erosion.

d. Appurtenant Structures

(1) Spillway

The 10-inch pipe was recently placed through the embankment using what appeared to be a "cut and cover" type of construction due to the fact that the soil over the pipe appeared to have been disturbed recently and had no vegetative cover. The only major concern with the spillway is that the flows through the pipe will flow down the embankment in an area which has already undergone some erosion at the toe as described in Section 3.1b. The pipe was unobstructed and appeared to be able to function properly. No seepage was observed around the pipe.

(2) Low Level Outlet

The 4-inch pipe is, reportedly, controlled by a valve, however, neither the pipe nor the valve were observed on the day of the inspection. Because the valve was not visible and water was observed flowing through the pipe, it is believed that the valve always remains open and could possibly be inoperable. The outlet does not appear to be obstructed since water was observed flowing over the top of the manhole structure. The only condition of any concern with the low level outlet is the erosion at the toe of the embankment apparently caused by discharges through the pipe as mentioned above and in Section 3.1b.

e. Reservoir Area

The water surface elevation was 768.9 feet above M.S.L. at the time of inspection. The surface area of the reservoir at the normal water level is about 6.5 acres. The reservoir rim, south and west sides, is flat with trees and shrubs growing at the shore line. With the exception of a small undercut along most of the natural reservoir rim, there was no evidence of instability. The power plant and its appurtenant structures are located on the reservoir rim.

f. Downstream Channel

The downstream channel, which carries flows from the spillway and the low level outlet, is overgrown with the tall vegetation and trees (see Photo 13). The width of the channel is approximately 10 feet for approximately 50 feet with side slopes of about 1V on 1H on both sides and a depth of about 3 feet. The channel then widens out to about 100 feet until it flows into another sedimentation pond directly downstream of the reservoir. The heavy growth of vegetation in the channel will affect the hydraulic efficiency of the channel.

3.2 Evaluation

The following deficiencies were observed during the visual inspection which could affect the safety of the dam. Remedial measures should be undertaken in the near future to correct these deficiencies.

1. The trees observed on the embankment pose a potential danger to the safety of the dam. Depending upon the extent of the root system, the roots of large trees present possible paths for piping through the embankment. The root systems can also do damage to the embankment from being uprooted by a storm.

2. The vegetation on the embankment, especially on the upstream slope, should be properly maintained. A heavy growth of vegetation on the embankment hinders a comprehensive inspection of the dam and potential problems could go undetected.

3. The wave erosion on the upstream slope, the surface runoff erosion on the downstream slope, and the sloughing and undermining of the downstream slope and toe adjacent to the left abutment do not appear to affect the stability of the dam in their present condition. However, continual erosion of the slope can only be detrimental to the stability of the dam.

4. Rodent activity observed on the embankment could jeopardize the safety of the dam. The holes created by the animals make avenues for possible piping.

5. The practice of allowing the low level outlet and the spillway on the left abutment to discharge directly onto the embankment can only be detrimental to the stability of the dam.

## SECTION 4: OPERATIONAL PROCEDURES

### 4.1 Procedures

There are no specific operational procedures for Moores Lake Dam. However, a coal ash slurry from the Municipal Power Plant is pumped into the reservoir three times a day for approximately 2 to 3 hours. The coal ash is then allowed to settle out of the solution. According to Mr. Anderson, the reservoir is dredged periodically to remove the accumulation of coal ash and the reservoir was last dredged in June of 1980. Also, Mr. Anderson stated that the depth of the reservoir, on the day of the inspection, was probably 5 feet at its deepest point.

### 4.2 Maintenance of Dam

The dam is maintained by work crews employed by the Columbia Water and Light Department. Mr. Anderson mentioned that the top of dam is mowed periodically. The upstream and downstream slopes are overgrown with large trees and dense vegetation. There was evidence of an abundance of rodent activity on the dam embankment.

### 4.3 Maintenance of Operating Facilities

According to Mr. Anderson, there is a 4-inch pipe and valve, which serves as a low level outlet, located adjacent to the new 10-inch spillway pipe. This could not be verified; however, the operable facilities associated with the dam are maintained by the Water and Light Department employees.

4.4 Description of Any Warning System in Effect

The inspection team is not aware of any warning system in use at the damsite.

4.5 Evaluation

The maintenance at Moores Lake Dam is inadequate. The remedial measures described in Section 7 should be undertaken to improve the condition of the dam.

## SECTION 5: HYDRAULIC/HYDROLOGIC

### 5.1 Evaluation of Features

#### a. Design Data

No hydrologic and hydraulic design data are available for Moores Lake Dam. The sizes of physical features utilized to develop the stage-outflow relation for the spillway and overtopping of the dam were prepared from field notes and sketches prepared during the field inspection. The reservoir elevation-area data were based on the U.S.G.S. Columbia, Missouri Quadrangle topographic maps (7.5 minute series). The spillway and overtop release rates and the reservoir elevation-area data are presented in Appendix B.

The hydrologic soil group of the watershed was determined from information available in the U.S.D.A. Soil Conservation Service publication "Missouri General Soil Map and Soil Association Descriptions", 1979. The Probable Maximum Precipitation (PMP) used to determine the Probable Maximum Flood (PMF) was determined by using the U.S. Weather Bureau publication, "Hydrometeorological Report No. 33" (April 1956). The 100-year flood were derived by using the 100-year rainfall of Jefferson City, Missouri.

#### b. Experience Data

It is believed that records of reservoir stage or spillway discharge are not maintained for this site.

#### c. Visual Observations

Observations made of the spillway during the visual inspection are discussed in Section 3.1d and evaluated in Section 3.2.

d. Overtopping Potential

Only the Probable Maximum Flood when routed through the reservoir, resulted in overtopping of the dam. The peak inflows of the PMF and one half of the PMF are 592 cfs and 296 cfs respectively. The peak outflow discharges for the PMF and one-half of the PMF are 282 and 3 cfs, respectively. The maximum capacity of the spillway just before overtopping the dam is only 4 cfs. The PMF overtopped the dam by 0.8 feet. The total duration of flow over the dam is 9 hours during the occurrence of the PMF. The reservoir/spillway system of Moores Lake Dam is capable of accommodating a flood equal to approximately 50 percent of the PMF just before overtopping the dam. The reservoir/spillway system of Moores Lake Dam will accommodate the one-percent chance flood without overtopping. The dam may be susceptible to erosion due to overtopping during the occurrence of the PMF.

The failure of the dam could cause extensive damage to the property downstream of the dam and possible loss of life. The estimated damage zone extends approximately two miles downstream of the dam. Within the damage zone there are the crossing of Interstate Highway I-70 immediately downstream of the dam, three commercial buildings, one trailer, a gas station and two large buildings.

## SECTION 6: STRUCTURAL STABILITY

### 6.1 Evaluation of Structural Stability

#### a. Visual Observations

There were no signs of settlement on the embankment. Items of distress observed on the embankment include the wave erosion of the upstream slope, the slough on the downstream slope, the undermining of the downstream toe, the rodent holes, and the deep surface erosion of the downstream face. In the absence of seepage and stability analyses, no quantitative evaluation of the structural stability can be made.

The spillway and the low level outlet appeared structurally stable; however, discharges through the low level outlet have caused erosion along the downstream slope.

#### b. Design and Construction Data

Design computations pertaining to the embankment were not available during the report preparation phase. Seepage and stability analyses comparable to the requirements of the "Recommended Guidelines for Safety Inspection of Dams" were not available. No embankment or foundation soil parameters were available for carrying out a conventional stability analysis on the embankment. No construction data or specifications relating to the degree of embankment compaction were available for use in a stability analysis.

c. Operating Records

No operating records were available relating to the stability of the dam or appurtenant structures. The water level on the day of the visual inspection was only an inch below the spillway crest. Due to the practices of pumping the coal ash slurry into the reservoir and periodically dredging the accumulated coal ash out of the reservoir, it is unknown what elevation is considered the normal operating pool for the reservoir. However, for all intents and purposes, the normal operating level is assumed to be at the spillway crest.

d. Post Construction Changes

The inspection team was informed of two post construction changes made at the damsite. In 1970, spoil material was placed on top of the embankment crest; hence, the irregular surface and the 1 to 2 foot increase in the crest elevation of the top of dam. Also, a new spillway pipe was recently installed through the left side of the embankment by cut and cover methods; the excavation extended to about a 4-foot depth below crest elevation. Both of these changes could have both negative and positive effects on the stability of the dam. No other changes are known to exist.

e. Seismic Stability

The dam is located in Seismic Zone 1, as defined in "Recommended Guidelines for Safety Inspection of Dams" prepared by the Corps of Engineers, and will not require a seismic stability analysis. An earthquake of the magnitude which would be expected in Seismic Zone 1 will not cause significant distress to a well designed and constructed earth dam. Available literature indicates that no active faults exist near the vicinity of the damsite.

## SECTION 7: ASSESSMENT/REMEDIAL MEASURES

### 7.1 Dam Assessment

The assessment of the general condition of the dam is based upon available data and visual inspection. Detailed investigations, testing and detailed computational evaluations are beyond the scope of a Phase I investigation; however, the investigation is intended to identify any need for such studies. The dam generally appears to be in poor physical condition. However, considering the reservoir depth and the ratio of the width to height at several sections of the dam, the functional condition of the dam appears to be fair.

It should be realized that the reported condition of the dam is based upon observations of field conditions at the time of inspection along with the field measurements made by the inspection team.

It is also important to note that the condition of a dam depends upon numerous and constantly changing internal and external conditions, and is evolutionary in nature. It would be incorrect to assume that the present condition of the dam will continue to represent the condition of the dam at some point in the future. Only through continued care and inspection can there be assurance that an unsafe condition could be detected.

#### a. Safety

The spillway capacity of Moores Lake Dam is found to be "Inadequate". The spillway/reservoir system will accommodate approximately 50 percent of the PMF without overtopping the dam. The surface soils in the embankment appear to be silty to sandy clay. The dam is overtopped by approximately one foot during the occurrence of the PMF. The dam may be susceptible to erosion due to overtopping of the dam during the PMF.

A quantitative evaluation of the safety of the embankment could not be made in view of the absence of seepage and stability analyses. The present embankment and appurtenant structures, however, reportedly have performed satisfactorily since their construction without failure. No evidence of the dam having ever been overtopped was observed. The safety of the dam can be improved if the deficiencies described in Sections 3.2 and 6.1.a are properly corrected as described in Section 7.2.

b. Adequacy of Information

The conclusions presented in this report are based upon field measurement, past performance and the present condition of the dam. Information on the design hydrology, hydraulic design, and operation and maintenance of the dam were not available. Seepage and stability analyses comparable to the requirements of the "Recommended Guidelines for Safety Inspection of Dams" were not available, which is considered a deficiency.

c. Urgency

The remedial measures recommended in Paragraph 7.2 should be accomplished within a reasonable period of time, and the item recommended in paragraph 7.2a should be pursued on a high priority basis.

d. Necessity for Phase II Inspection

Based upon results of the Phase I inspection, a Phase II inspection is not felt to be necessary.

## 7.2 Remedial Measures

### a. Alternatives

One of the following mitigation measures should be undertaken under the guidance of an Engineer experienced in design and construction of earth dams to avoid severe consequences of dam failure from overtopping.

1. Increase the spillway capacity to pass the PMF without overtopping the dam.
2. Increase the height of the dam enough to pass the PMF without overtopping the dam; an investigation should also be done which includes studying the effects on the structural stability of the existing embankment. The overtopping depth during the occurrence of the PMF, stated in Section 5.1.d, is not the required or recommended increase in the height of the dam.
3. A combination of 1 and 2 above.
4. Provide a highly reliable flood warning system (generally does not prevent damage but avoids loss of life).

### b. O & M Procedures

1. The downstream slope where the sloughing and the undermining of the downstream toe adjacent to the low level outlet have occurred should be stabilized and the areas should be protected from further damage.
2. The trees and bushes should be removed from the embankment and future growth should be prevented. Removal of large trees should be under the guidance of an engineer experienced in the design and construction of earth dams.

3. The vegetation on the embankment, especially the vegetation on the upstream slope, should be properly maintained and an adequate vegetative cover should be retained on the embankment to protect it from surface erosion. Large vegetation, such as bushes and trees, should be prevented from growing on the embankment.
4. The erosion due to wave action on the upstream slope and due to surface runoff on the downstream slope should be properly repaired and adequately protected from further damage.
5. All burrowing animals should be eliminated from the embankment and their burrows properly backfilled and compacted.
6. Measures should be undertaken either to protect the embankment slope to be able to withstand discharges through the spillway and low level outlet or to direct the two structures' discharges away from the embankment.
7. Seepage and stability analyses should be performed by a professional engineer experienced in the design and construction of earth dams.
8. The owner should initiate the following programs:
  - (a) Periodic inspection of the dam by a professional engineer experienced in the design and construction of earth dams.
  - (b) Set up a maintenance schedule and log all visits to the dam for operation, repairs and maintenance.

PLATES

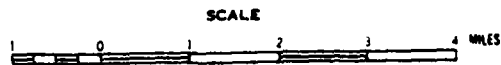
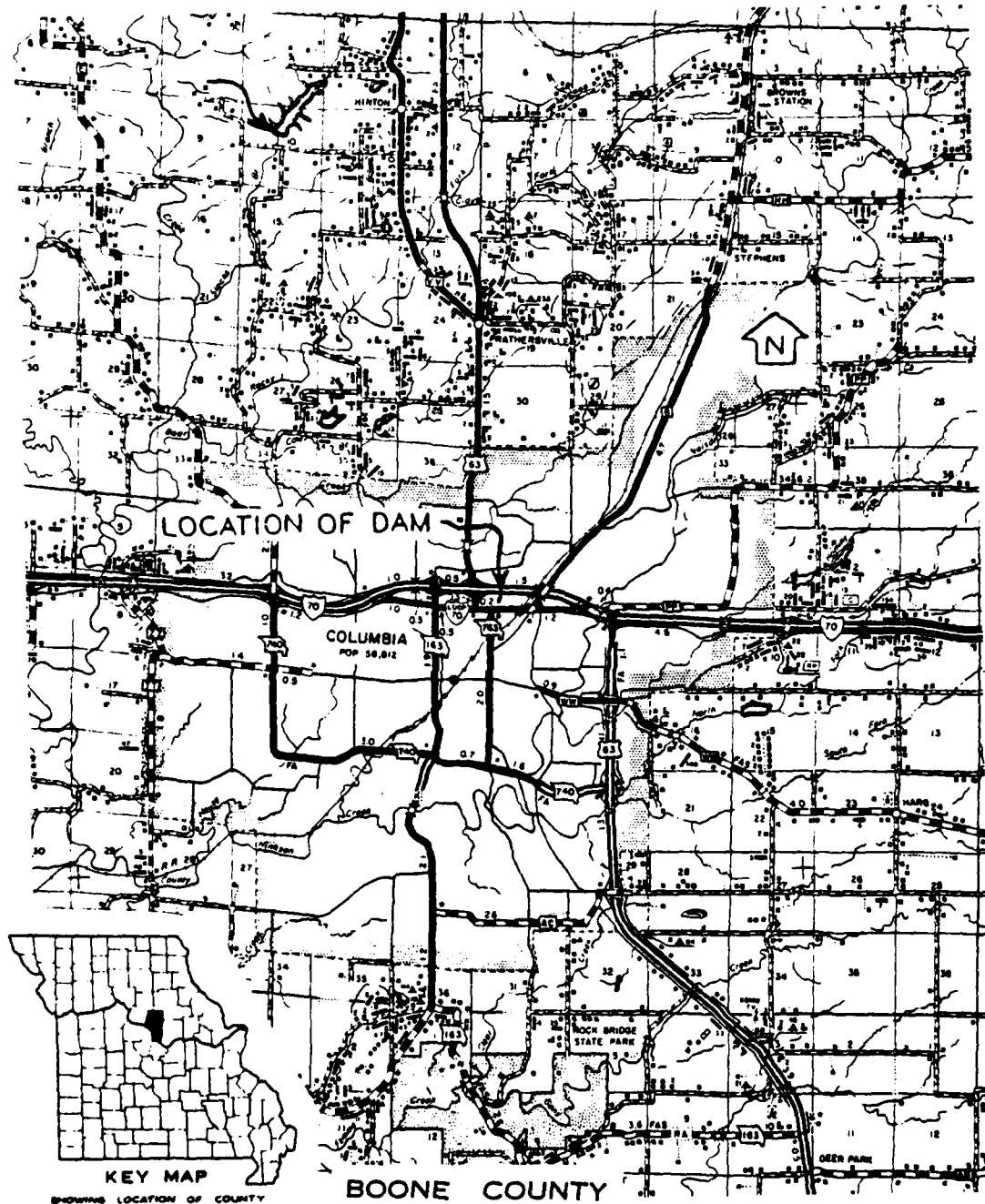

POLYCONIC PROJECTION

LOCATION MAP - MOORES LAKE DAM

MO-11173

PLATE 1A

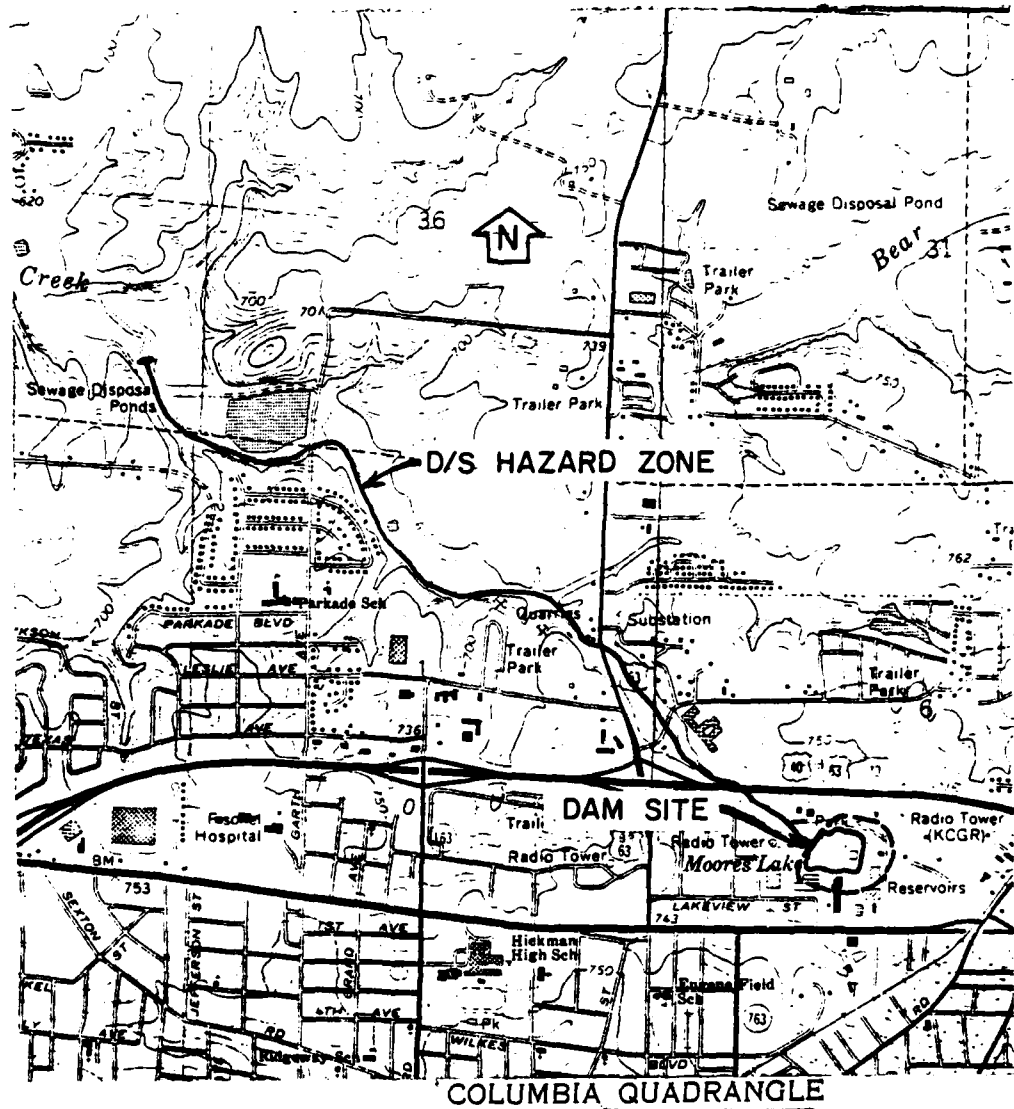

DRAINAGE BOUNDARY

SCALE 1:24,000

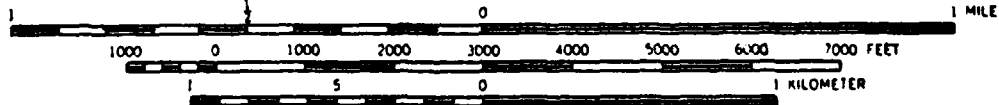

CONTOUR INTERVAL 10 FEET  
DATUM IS MEAN SEA LEVEL

MOORES LAKE DAM (MO. 11173)  
DRAINAGE BASIN AND  
DOWNSTREAM HAZARD ZONE

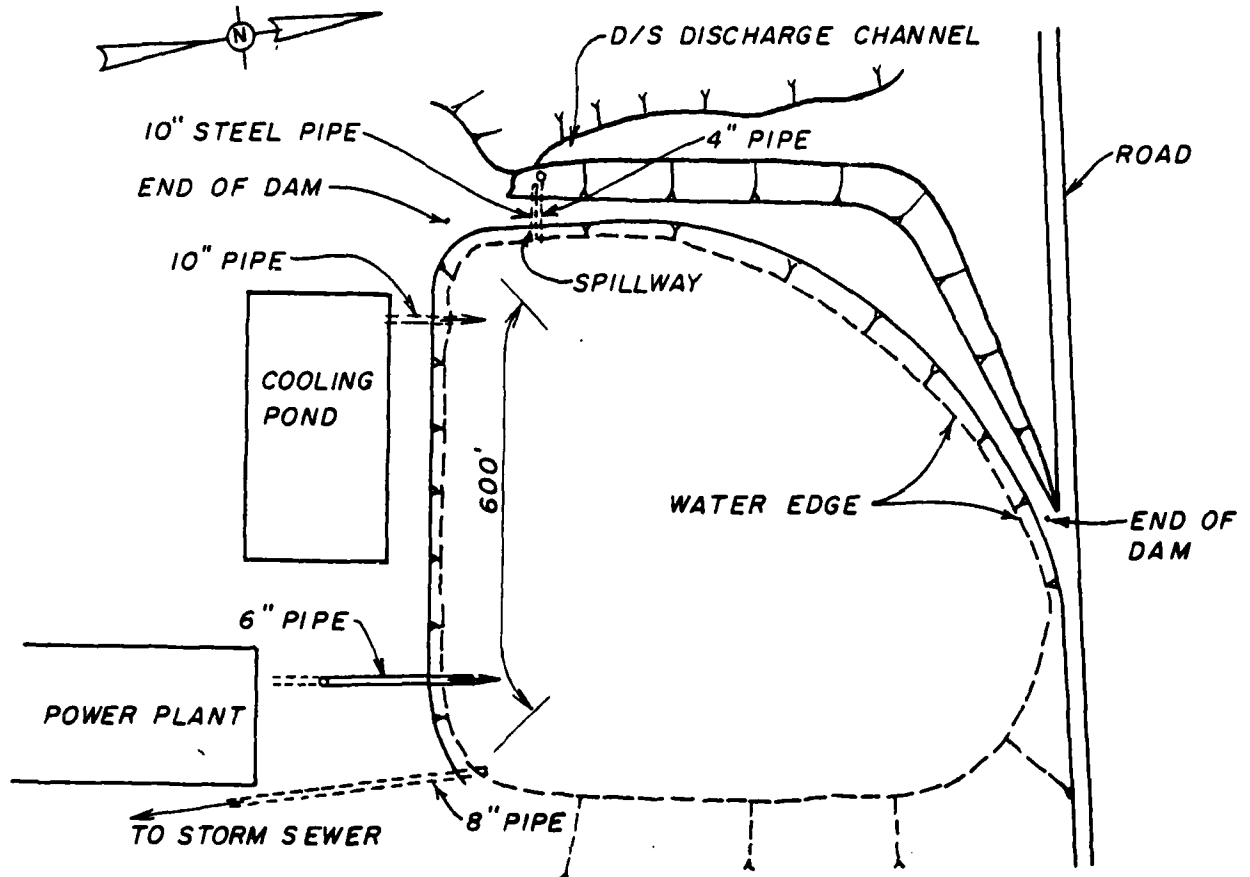

PLAN

SCALE:  
HORIZ. 1" = 200'

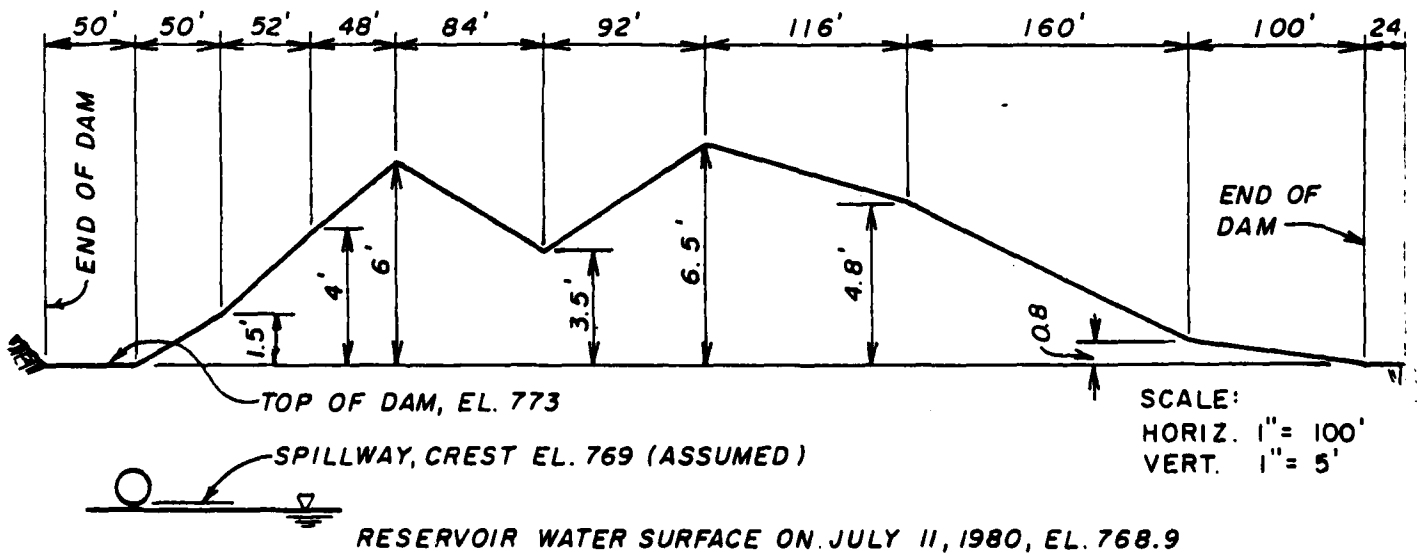

ELEVATION

NOTE: ALL ELEVATIONS ARE SHOWN AS FEET ABOVE M.S.L.

MOORES LAKE DAM (MO. 11173)  
PLAN AND ELEVATION

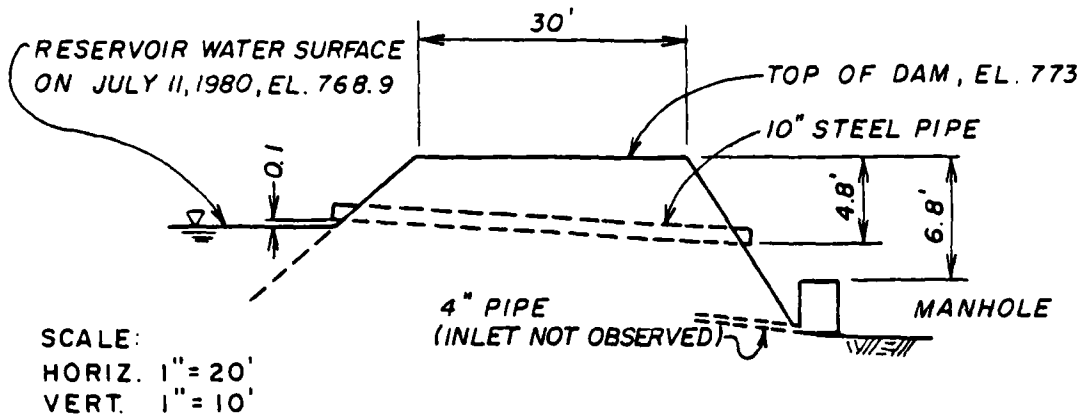

SECTION THROUGH EMBANKMENT  
AT LEFT ABUTMENT

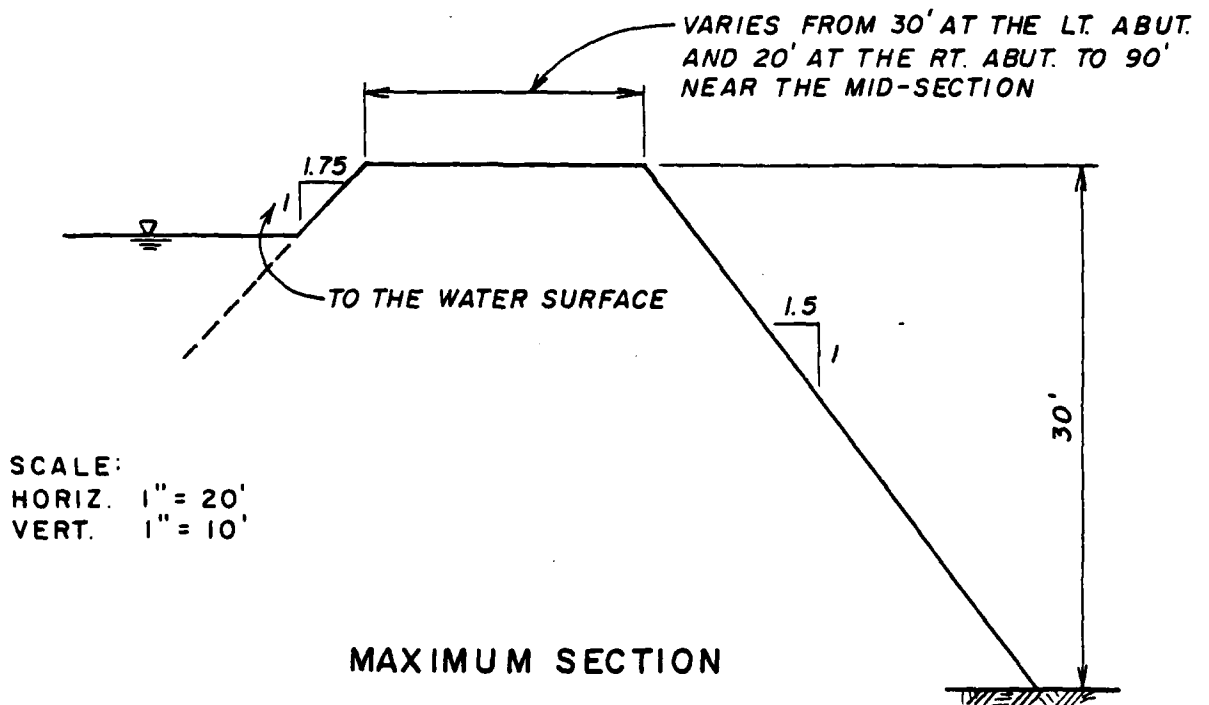

MOORES LAKE DAM (MO. 11173)  
MAXIMUM SECTION OF EMBANKMENT

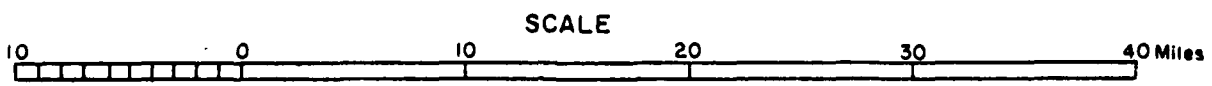
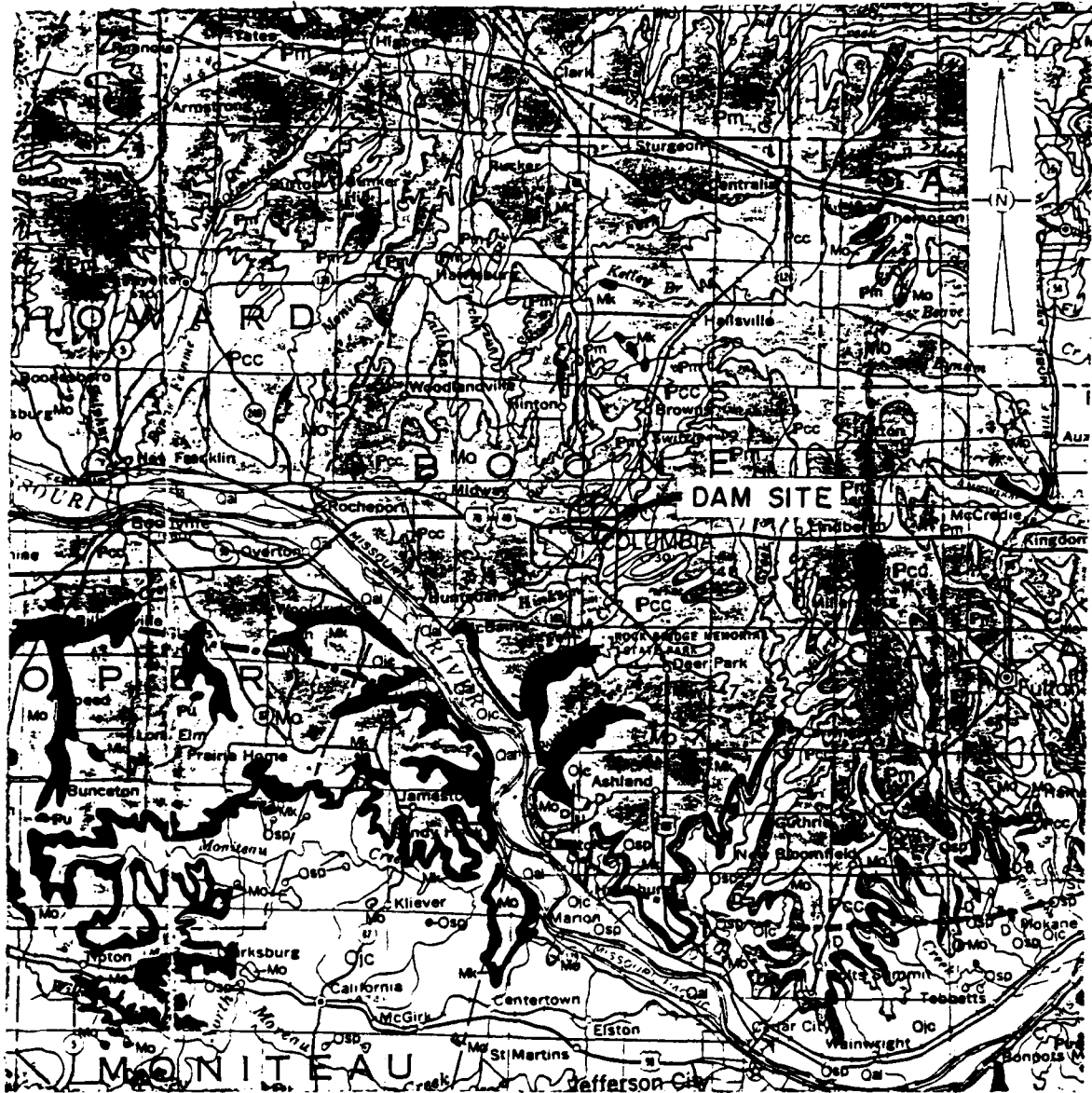

⊕ LOCATION OF DAM

NOTE: LEGEND OF THIS DAM IS ON PLATE 5

REFERENCE:

GEOLOGIC MAP OF MISSOURI  
DEPARTMENT OF NATURAL RESOURCES  
MISSOURI GEOLOGICAL SURVEY  
KENNETH H. ANDERSON, 1979

REGIONAL GEOLOGICAL MAP  
OF  
MOORES LAKE DAM

LEGEND

<u>PERIOD</u>	<u>SYMBOL</u>	<u>DESCRIPTION</u>
QUATERNARY	Qal	ALLUVIUM: SAND, SILT, GRAVEL
PENNSYLVANIAN	Pu	PENNSYLVANIAN UNDIFFERENTIATED
	Pm	MARMATON GROUP: CYCLIC DEPOSITS OF SHALE, LIMESTONE AND SANDSTONE
	Pcc	CHEROKEE GROUP: CYCLIC DEPOSITS OF SHALE, LIMESTONE AND SANDSTONE
MISSISSIPPIAN	Mo	KEOKUK - BURLINGTON FORMATION: CHERTY GRAYISH BROWN SANDY LIMESTONE
	Mk	CHOUTEAU GROUP: NORTHVIEW AND BACHELOR FORMATION (LIMESTONE AND SHALE)
DEVONIAN	D	SULPHUR SPRING GROUP: GLEN PARK LIMESTONE AND GRASSY CREEK SHALE
ORDOVICIAN	Osp	ST PETER SANDSTONE
	Ojc.	SMITHVILLE FORMATION, POWELL DOLOMITE

APPENDIX A  
PHOTOGRAPHS

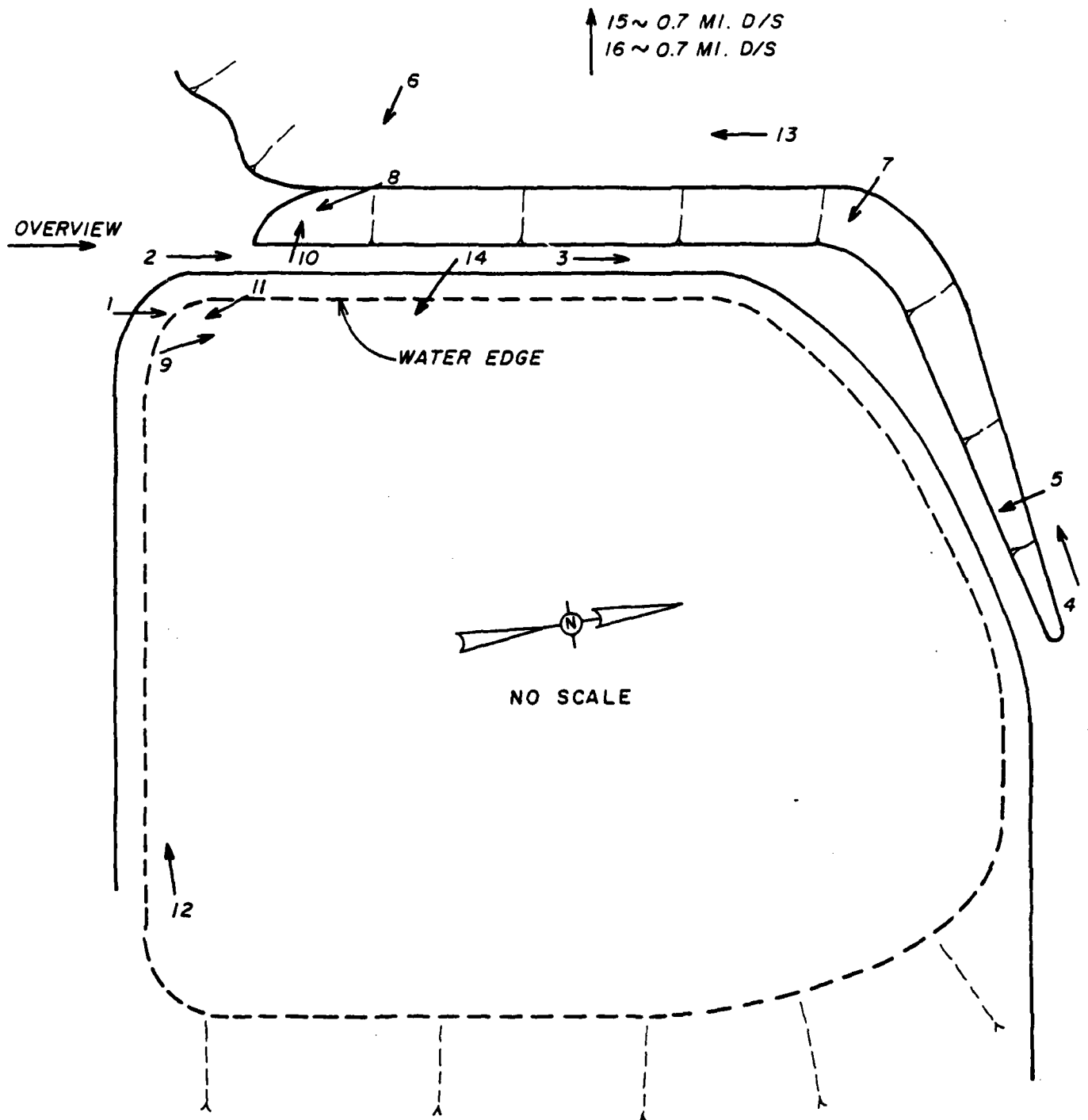

PHOTO INDEX  
FOR  
MOORES LAKE DAM

Moores Lake Dam

Photographs

- Photo 1 - View of the upstream slope from the left abutment showing the dense vegetation.
- Photo 2 - View of a portion of the top of dam from the left abutment. Note the disturbed area of soil in the foreground due to the recently constructed 10-inch spillway pipe.
- Photo 3 - View of the top of dam showing the maximum top width at the mid-section of the dam.
- Photo 4 - View of the downstream slope from the right abutment showing the dense vegetation on the slope.
- Photo 5 - View of an animal burrow on the downstream slope.
- Photo 6 - View of a large erosion scarp on the downstream slope just downstream of the two spillway pipes at the left abutment.
- Photo 7 - View of a large erosional gully on the downstream slope.
- Photo 8 - View of the discharge over the top of the manhole of the 4-inch outlet pipe showing the undermining of the toe of the embankment to the left of the manhole (in photo). Note the location of the outlet of the 10-inch pipe above and to the left (in photo) of the manhole.
- Photo 9 - View of the inlet to the 10-inch spillway pipe.

- Photo 10 - View of the top of the manhole used as the outlet structure for the 4-inch outlet pipe.
- Photo 11 - View of the 10-inch pipe that drains the excess water from the cooling pond into the reservoir.
- Photo 12 - View of the outlet end of the 6-inch pipe through which the coal ash slurry from the power plant is pumped.
- Photo 13 - View of the downstream channel.
- Photo 14 - View of the reservoir and rim.
- Photo 15 - View of buildings believed to be in the downstream hazard zone.
- Photo 16 - View of a gas station believed to be in the downstream hazard zone.

Moore's Lake Dam



Photo 1



Photo 2

Moore's Lake Dam



Photo 3



Photo 4

Moore's Lake Dam



Photo 5



Photo 6

Moore's Lake Dam



Photo 7

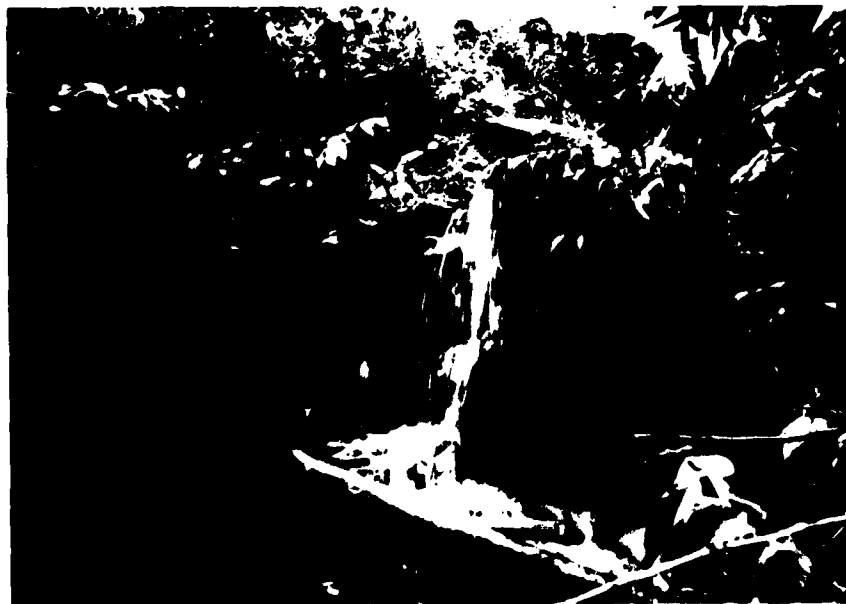

Photo 8

Moore's Lake Dam

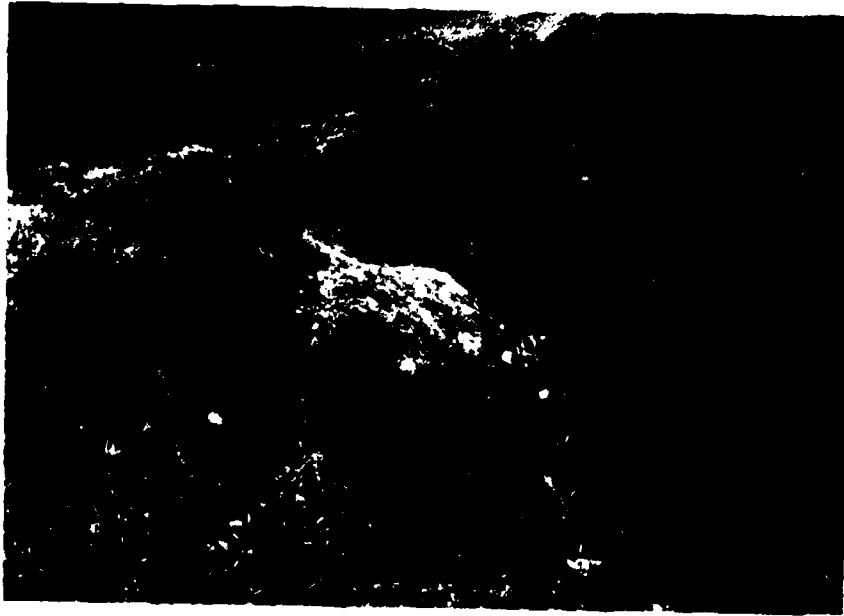

Photo 9

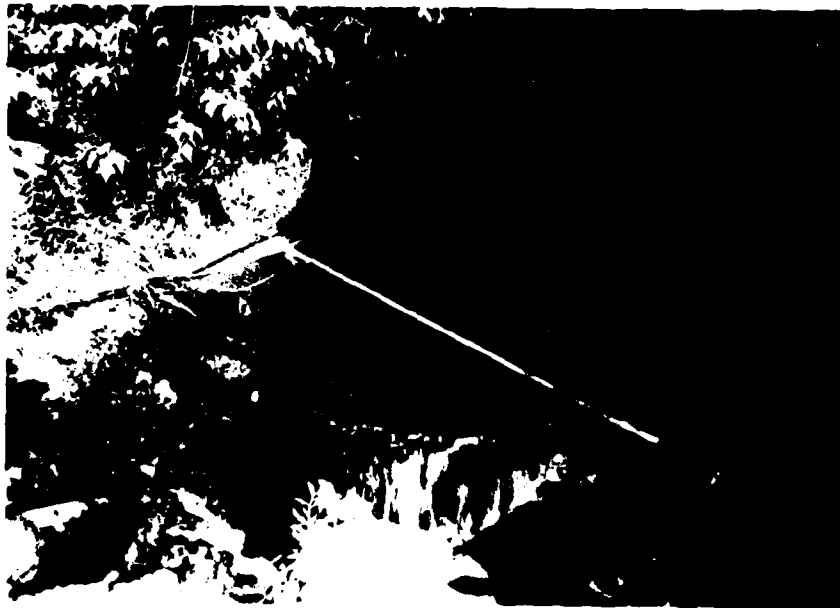

Photo 10

Moore's Lake Dam



Photo 11



Photo 12

Moores Lake Dam

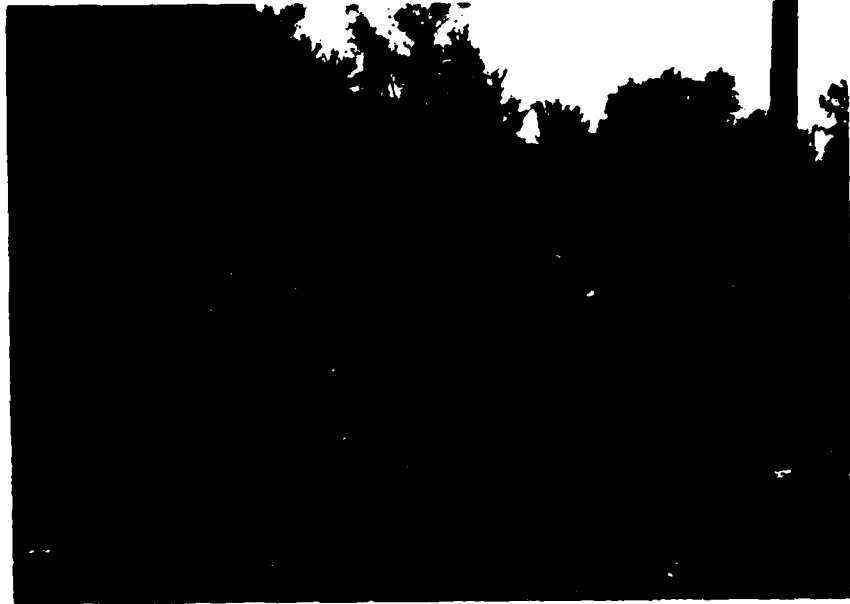

Photo 13



Photo 14

Moores Lake Dam

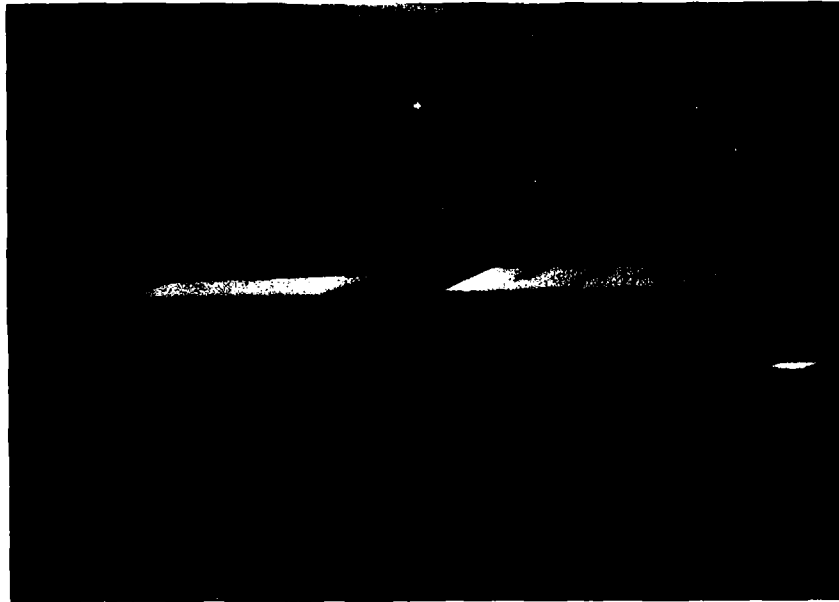

Photo 15



Photo 16

APPENDIX B

HYDROLOGIC AND HYDRAULIC COMPUTATIONS

MOORES LAKE DAM

HYDROLOGIC AND HYDRAULIC DATA, ASSUMPTIONS AND METHODOLOGY

1. SCS Unit Hydrograph and HEC-1DB are used to develop the inflow hydrographs, and the hydrologic inputs are as follows:
  - (a) Twenty-four hour probable maximum precipitation from Hydrometeorological Report No. 33, and 100-year 24-hour rainfall of Jefferson City, Missouri.
  - (b) Drainage area = 21 acraa.
  - (c) Lag time = 0.03 hour.
  - (d) Hydrologic Soil Group:  
Soil Group "C"
  - (e) Runoff curve number:  
CN = 82 for AMC II and CN = 92 for AMC III.
2. Spillway release rates are based on pipe flow assuming Manning's  $n = 0.02$ . Flow rates over the dam are based on broad crested weir equation  $Q = CLH^{3/2}$  and critical depth assumption.
3. Floods are routed through Moores Lake to determine the capability of its spillway.

DAM SAFETY INSPECTION

SHEET NO. \_\_\_\_\_ OF \_\_\_\_\_

MOORES LAKE DAM (MO 11173)

JOB NO. \_\_\_\_\_

SPILLWAY DISCHARGE

BY DC DATE 7/23/86  
MLO

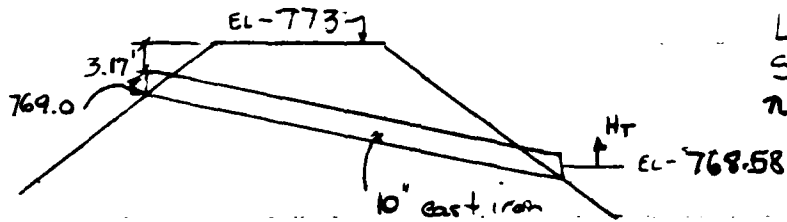

L = 45'  
S = 1.48%  
n = .02

Pressure Flows

$K_e = 0.5$  (entrance loss)

$K_c = \frac{29.16 n^2}{R^{4/3}}$

$R = \frac{A}{P} = \frac{\pi r^2}{2r} = \frac{r}{2} = 2.5 \frac{1}{12} \text{ ft}$

$K_c = \frac{29.16 (.02)^2}{(.2083)^{4/3}} = .094$

$Q = A \sqrt{\frac{2g H_T}{1 + K_e + K_c}} = \pi \left(\frac{5}{12}\right)^2 \sqrt{\frac{64.4 H_T}{3.75}} = 1.8 \sqrt{H_T}$

$H_T = WSEL - 768.58$

DAM SAFETY INSPECTION

SHEET NO. \_\_\_\_\_ OF \_\_\_\_\_

MOORE LAKE DAM - (MO 11173)

JOB NO. \_\_\_\_\_

OVERTOP RATING CURVE

BY D.C. DATE 7/23/80

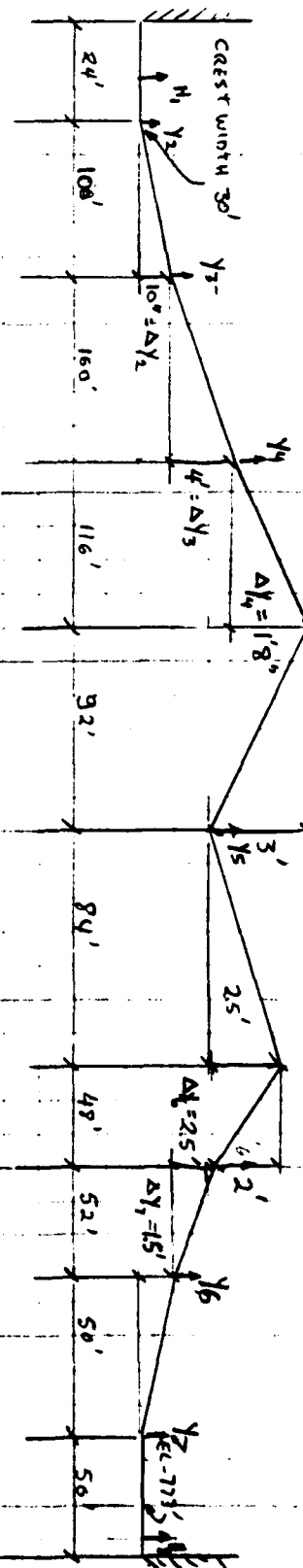

H1	C1	L1	$Q_{1,2} = \frac{H_1^2}{L_1}$	C2	L2	$Q_{2,3} = \frac{H_2^2}{L_2}$	H2	$H_2^{2/3}$	T2	A2	$Q_2 = \sqrt{\frac{A_2^3}{T_2}}$	H3	$H_3^{2/3}$	T3	A3	$Q_3 = \sqrt{\frac{A_3^3}{T_3}}$	H4	$H_4^{2/3}$	T4	A4
0	2.99	24	1.79	2.99	50	24.00	3	24	298	3.82	4.89	—	—	—	—	—	—	—	—	
.3	3.03	24	3.77	3.03	50	70.85	.6	.48	57.6	13.52	38.43	—	—	—	—	—	—	—	—	
1.0	3.04	24	7.84	3.04	50	15.75	1.0	.80	96.0	38.4	13.81	.17	.13	5.3	.36	—	—	—	—	
1.3	3.04	24	10.11	3.04	50	22.73	1.3	1.01	100.0	59.89	25.44	.47	.37	14.93	2.79	6.83	—	—	—	
1.6	3.04	24	14.87	3.04	50	30.83	1.6	1.21	100.0	79.89	37.76	.77	.61	24.47	7.82	2.64	—	—	—	
2.0	3.05	24	21.79	3.05	50	43.71	2.0	1.47	100.0	105.56	61.39	1.17	.93	37.35	12.82	6.54	—	—	—	
2.3	3.05	24	25.14	3.05	50	53.54	2.3	1.67	100.0	125.56	75.33	1.47	1.17	44.93	22.83	11.67	—	—	—	
2.6	3.05	24	31.83	3.05	50	63.23	2.6	1.87	100.0	145.56	98.49	1.77	1.41	56.53	37.85	14.57	—	—	—	
3.0	3.05	24	39.57	3.05	50	79.85	3.0	2.14	100.0	172.2	121.51	2.17	1.73	69.33	60.97	20.43	—	—	—	



ECI-4

PRC ENGINEERING CONSULTANTS, INC.

DAM SAFETY INSPECTION / MISSOURI

SHEET NO. \_\_\_\_\_ OF \_\_\_\_\_

MOORES LAKE DAM (MO 11173)

JOB NO. 1263

COMBINED RATING CURVE

BY DC DATE 7/23/80  
KLS

Datum = 768.58

Reservoir Water Surface Elev.	H <sub>T</sub>	Spillway Discharge $Q = 1.8 \sqrt{H_T}$	Emergency Spillway Discharge	Discharge Over Top of Dam	Combined Discharge
769.0	—	—		—	0
769.83	1.25	2.0		—	2
771.0	2.42	2.8		—	3
772.0	3.42	3.3		—	3
773.0	4.42	3.8		—	4
773.3	4.72	3.9		45	49
773.6	5.02	4.0		153	157
774.0	5.42	4.2		401	405
774.3	5.72	4.3		670	674
774.6	6.02	4.4		1001	1005
775.0	6.42	4.5		1540	1546
775.3	6.72	4.7		2016	2021
775.6	7.02	4.8		2552	2557
776.0	7.42	4.9		3360	3365

ECI-4

# PRC ENGINEERING CONSULTANTS, INC.

DAM SAFETY INSPECTION - MISSOURI

SHEET NO. 1 OF 1

DAM NAME: Crooked Creek Dam / ID NO.: 173

JOB NO. 1263

RESERVOIR ELEVATION - AREA DATA

BY [Signature] DATE 7/22

ELEV. (M.S.L.) (Ft.)	RESERVOIR SURFACE AREA (Acres)	REMARKS
762	0	Estimated streambed ups of Dam
769	6.5	Spillway Crest (Assumed)
770	7.0	Measured on USGS Quad
773	8.5	Top of dam.
780	11.0	Measured on USGS Quad

PRC ENGINEERING CONSULTANTS, INC.

DAM SAFETY INSPECTION / MISSOURI SHEET NO. 1 OF 1  
 DAM NAME: MOORES LAKE DAM (MO 11173) JOB NO. 1263  
 UNIT HYDROGRAPH PARAMETERS BY D.C. KLO DATE 7/23/82

- 1) DRAINAGE AREA,  $A = .033$  sq. mi. = ( 21.0 acres)
- 2) LENGTH OF STREAM,  $L = ( 25 \text{ " } \times 2000 \text{ ' } = 500 \text{ ' } ) = 0.095 \text{ mi.}$
- 3) ELEVATION AT DRAINAGE DIVIDE ALONG THE LONGEST STREAM,  
 $H_1 = 792'$
- 4) ELEVATION OF RESERVOIR AT SPILLWAY CREST,  $H_2 = 769$
- 5) ELEVATION OF CHANNEL BED AT  $0.85L$ ,  $E_{85} = 788'$
- 6) ELEVATION OF CHANNEL BED AT  $0.10L$ ,  $E_{10} = 771'$
- 7) AVERAGE SLOPE OF THE CHANNEL,  $S_{AVG} = (E_{85} - E_{10}) / 0.75L = .045$
- 8) TIME OF CONCENTRATION:

A) BY KIRPICH'S EQUATION,

$$t_c = [(11.9 \times L^3) / (H_1 - H_2)]^{0.385} = \left[ \frac{11.9 (.095)^3}{792 - 769} \right]^{0.385} = .05 \text{ hr}$$

B) BY VELOCITY ESTIMATE,

SLOPE = 4.5%  $\Rightarrow$  AVG. VELOCITY = 3 fps

$$t_c = L / V = 500 / 3(60)(60) = 0.05 \text{ hr}$$

USE  $t_c = .05$

- 9) LAG TIME,  $t_x = 0.6 t_c = .03$
- 10) UNIT DURATION,  $D \leq t_x / 3 = .01$  < 0.083 hr.

USE  $D = .083$

11) TIME TO PEAK,  $T_p = D/2 + t_x = .07$

12) PEAK DISCHARGE,

$$q_p = (484 \times A) / T_p = 228 \text{ cfs}$$

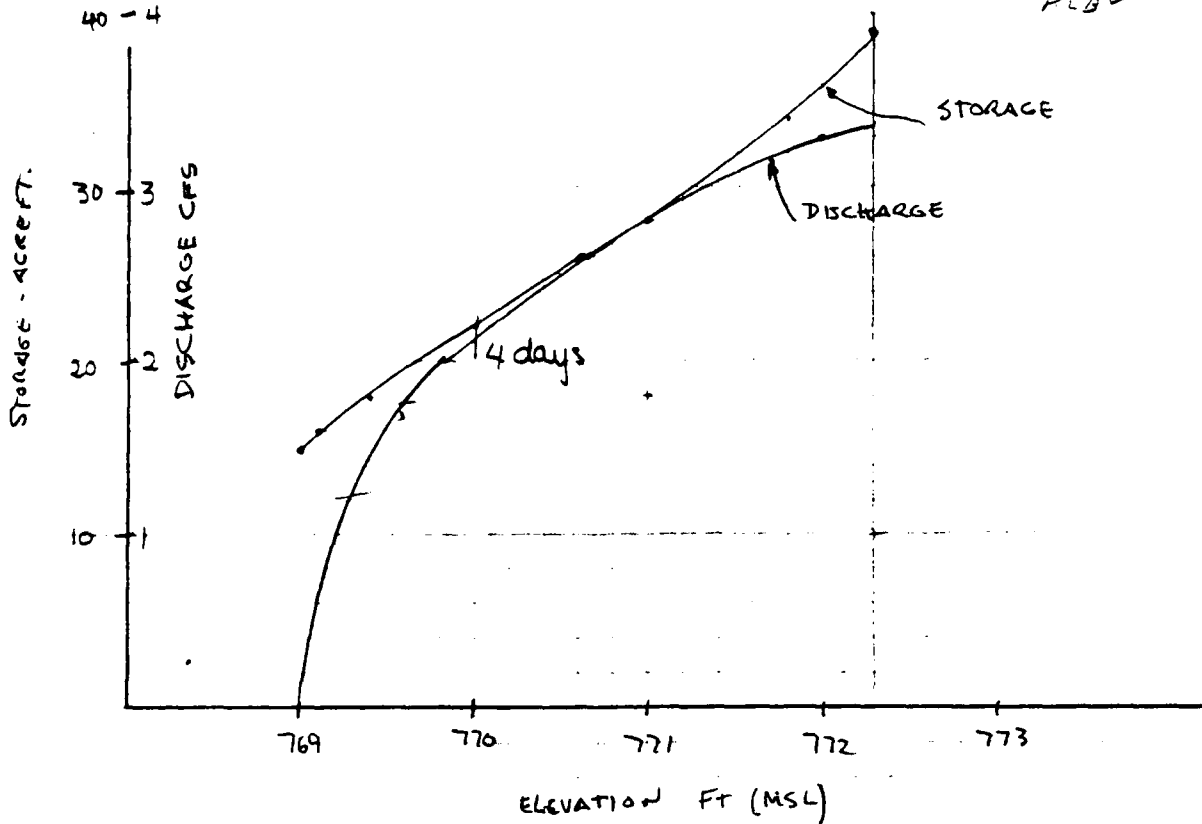

Stage	Storage	Discharge	$\Delta t$	$\Sigma t$
772.3	39	3.35	0	1
772.0	36	3.3	.45	1.45
771.4	31	3.05	.79	2.25
771.0	28	2.8	.52	2.77
770.6	26	2.6	.37	3.14
770.0	22	2.1	.86	4.00 days

∴ start PMF Routing at 770'

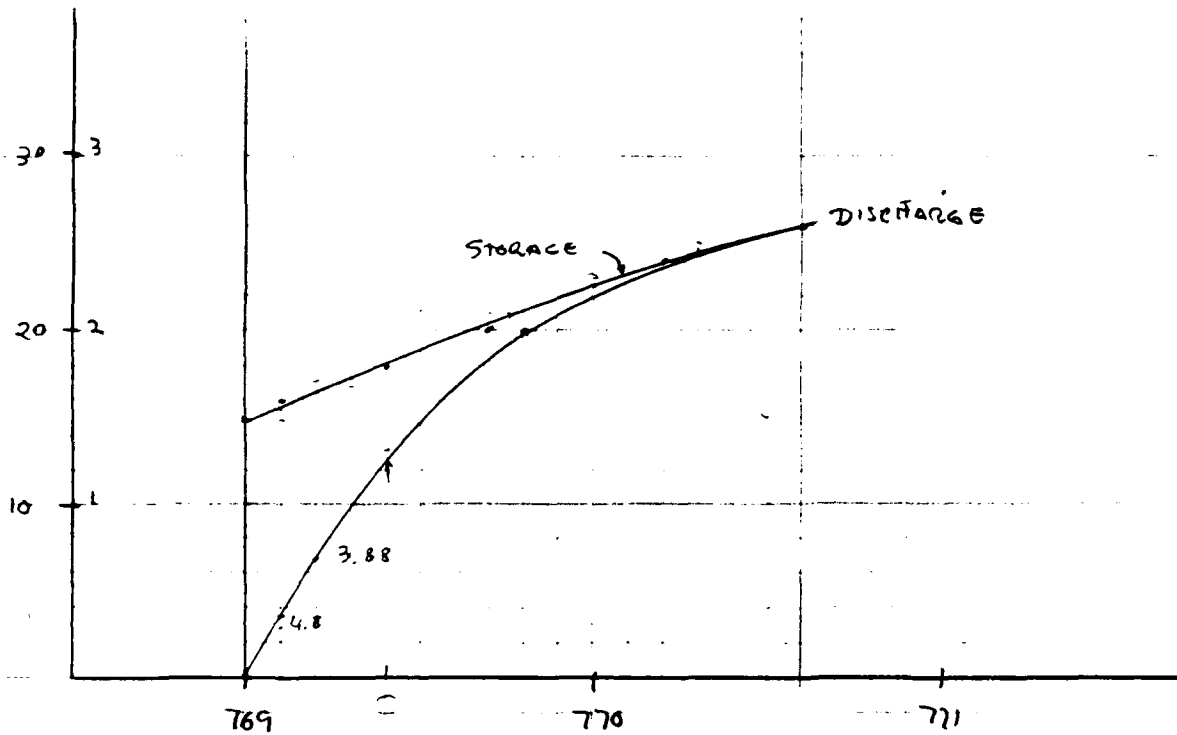

Stage	Storage	Discharge	$\Delta t$	$\Sigma t$
770.6	26	2.6	0	1 days
770.2	24	2.35	.39	1.39
770	23	2.2	.21	1.60
769.8	21	2.0	.48	2.08
769.5	19	1.5	.58	2.65
769.4	18	1.25	.37	3.02
769.2	16.5	.7	.78	3.80
769.1	15.5	.35	.96	4.76

Use 769.2 for starting 50% PMF Routing

\*\*\*\*\*  
 FLOOD HYDROGRAPH PACKAGE (HEC-1)  
 DAM SAFETY VERSION JULY 1978  
 LAST MODIFICATION 26 FEB 79  
 \*\*\*\*\*

LINE	PARAMETER	VALUE	UNIT	PARAMETER	VALUE	UNIT
1	A1			DAM SAFETY INSPECTION MISSOURI		
2	A2			MOORES LAKE DAM (MO 11173)		
3	A3			PMF		
4	B	300				
5	B1	5				
6	J1	1				
7	J1	1				
8	K			MO11173		
9	K1			INPUT PRECIPITATION INDEX, RATIOS, AND UNIT HYDROGRAPH PARAMETERS		
10	M	1				
11	M	2	.033			
12	T	24.8	130			
13	D2	.03				
14	X					
15	K			MO11173		
16	K1			ROUTE HYDROGRAPH THROUGH MOORES LAKE DAM (MO 11173)		
17	Y					
18	Y1					
19	Y4	769	769.83	771	772	773
20	Y4	775	775.3	775.6	776	777
21	Y5	0	2	3	4	49
22	Y5	1546	2021	2557	3365	157
23	EA	0	6.5	7	8.5	11
24	EE	762	769	770	773	780
25	EE	769				
26	SD	773				
27	K	99				



NO. DA HR-MN PERIOD RAIN EXCS LOSS END-OPERATION FLOW

NO. DA	HR-MN	PERIOD	RAIN	EXCS	LOSS	COMP. D	NO. DA	HR-MN	PERIOD	RAIN	EXCS	LOSS	COMP. E
1.01	1.05	1	.01	.00	.01	1	1.01	18.35	151	.21	.26	.00	.50
1.01	1.10	2	.01	.00	.01	1	1.01	18.40	152	.21	.20	.00	.50
1.01	1.15	3	.01	.00	.01	1	1.01	18.45	153	.21	.20	.00	.50
1.01	1.20	4	.01	.00	.01	1	1.01	18.50	154	.21	.20	.00	.50
1.01	1.25	5	.01	.00	.01	1	1.01	18.55	155	.21	.20	.00	.50
1.01	1.30	6	.01	.00	.01	1	1.01	19.00	156	.21	.20	.00	.50
1.01	1.35	7	.01	.00	.01	1	1.01	19.05	157	.25	.25	.00	.50
1.01	1.40	8	.01	.00	.01	1	1.01	19.10	158	.25	.25	.00	.50
1.01	1.45	9	.01	.00	.01	1	1.01	19.15	159	.25	.25	.00	.50
1.01	1.50	10	.01	.00	.01	1	1.01	19.20	160	.25	.25	.00	.50
1.01	1.55	11	.01	.00	.01	1	1.01	19.25	161	.25	.25	.00	.50
1.01	2.00	12	.01	.00	.01	1	1.01	19.30	162	.25	.25	.00	.50
1.01	2.05	13	.01	.00	.01	1	1.01	19.35	163	.25	.25	.00	.50
1.01	2.10	14	.01	.00	.01	1	1.01	19.40	164	.25	.25	.00	.50
1.01	2.15	15	.01	.00	.01	1	1.01	19.45	165	.25	.25	.00	.50
1.01	2.20	16	.01	.00	.01	1	1.01	19.50	166	.25	.25	.00	.50
1.01	2.25	17	.01	.00	.01	1	1.01	19.55	167	.25	.25	.00	.50
1.01	2.30	18	.01	.00	.01	1	1.01	20.00	168	.25	.25	.00	.50
1.01	2.35	19	.01	.00	.01	1	1.01	20.05	169	.31	.31	.00	.75
1.01	2.40	20	.01	.00	.01	1	1.01	20.10	170	.31	.31	.00	.75
1.01	2.45	21	.01	.00	.01	1	1.01	20.15	171	.31	.31	.00	.75
1.01	2.50	22	.01	.00	.01	1	1.01	20.20	172	.31	.31	.00	.75
1.01	2.55	23	.01	.00	.01	1	1.01	20.25	173	.31	.31	.00	.75
1.01	3.00	24	.01	.00	.01	1	1.01	20.30	174	.31	.31	.00	.75
1.01	3.05	25	.01	.00	.01	1	1.01	20.35	175	.31	.31	.00	.75
1.01	3.10	26	.01	.00	.01	1	1.01	20.40	176	.31	.31	.00	.75
1.01	3.15	27	.01	.00	.01	1	1.01	20.45	177	.31	.31	.00	.75
1.01	3.20	28	.01	.00	.01	1	1.01	20.50	178	.31	.31	.00	.75
1.01	3.25	29	.01	.00	.01	1	1.01	20.55	179	.31	.31	.00	.75
1.01	3.30	30	.01	.00	.01	1	1.01	21.00	180	.31	.31	.00	.75
1.01	3.35	31	.01	.00	.01	1	1.01	21.05	181	.19	.19	.00	.56
1.01	3.40	32	.01	.00	.01	1	1.01	21.10	182	.38	.38	.00	.85
1.01	3.45	33	.01	.00	.01	1	1.01	21.15	183	.38	.38	.00	.85
1.01	3.50	34	.01	.00	.01	1	1.01	21.20	184	.57	.56	.00	1.31
1.01	3.55	35	.01	.00	.01	1	1.01	21.25	185	.66	.66	.00	1.68
1.01	4.00	36	.01	.00	.01	1	1.01	21.30	186	1.60	1.60	.00	3.85
1.01	4.05	37	.01	.00	.01	1	1.01	21.35	187	2.64	2.63	.00	5.93
1.01	4.10	38	.01	.00	.01	1	1.01	21.40	188	1.04	1.04	.00	2.34
1.01	4.15	39	.01	.00	.01	1	1.01	21.45	189	.66	.66	.00	2.11
1.01	4.20	40	.01	.00	.01	1	1.01	21.50	190	.57	.56	.00	1.58
1.01	4.25	41	.01	.00	.01	1	1.01	21.55	191	.38	.38	.00	1.10
1.01	4.30	42	.01	.00	.01	1	1.01	22.00	192	.38	.38	.00	1.10
1.01	4.35	43	.01	.00	.01	1	1.01	22.05	193	.29	.29	.00	.89
1.01	4.40	44	.01	.00	.01	1	1.01	22.10	194	.29	.29	.00	.75
1.01	4.45	45	.01	.00	.01	1	1.01	22.15	195	.29	.29	.00	.74
1.01	4.50	46	.01	.00	.01	1	1.01	22.20	196	.29	.29	.00	.74
1.01	4.55	47	.01	.00	.01	1	1.01	22.25	197	.29	.29	.00	.74
1.01	4.00	48	.01	.00	.01	1	1.01	22.30	198	.29	.29	.00	.74
1.01	4.05	49	.01	.00	.01	1	1.01	22.35	199	.29	.29	.00	.74
1.01	4.10	50	.01	.00	.01	1	1.01	22.40	200	.29	.29	.00	.74
1.01	4.15	51	.01	.00	.01	1	1.01	22.45	201	.29	.29	.00	.74
1.01	4.20	52	.01	.00	.01	1	1.01	22.50	202	.29	.29	.00	.74
1.01	4.25	53	.01	.00	.01	1	1.01	22.55	203	.29	.29	.00	.74
1.01	4.30	54	.01	.00	.01	1	1.01	23.00	204	.29	.29	.00	.74
1.01	4.35	55	.01	.00	.01	1	1.01	23.05	205	.23	.23	.00	.52







PEAK FLOW AND STORAGE (END OF PERIOD) SUMMARY FOR MULTIPLE PLAN-RATIO ECONOMIC COMPUTATIONS  
 FLOW IN CUBIC FEET PER SECOND (CUBIC METERS PER SECOND)  
 AREA IN SQUARE KILOMETERS (SQUARE KILOMETERS)

RATIOS APPLIED TO FLOWS

OPERATION STATION AREA PLAN RATIO 1  
 1.00

HYDROGRAPH AT 011175 .03 593  
 .03 16.751

ROUTED TO 011175 .03 282  
 .03 4.081

SUMMARY OF DAM SAFETY ANALYSIS

PLAN 1	INITIAL VALUE	SPILLWAY CREST	TOP OF DAM
	ELEVATION	ELEVATION	ELEVATION
	STORAGE	769.00	775.00
	OUTFLOW	15	16
		0	9

RATIO	MAXIMUM	MAXIMUM	DURATION	TIME OF	TIME OF
OF	RESERVOIR	DEPTH	OVER TOP	MAX	FAILURE
TPW	US-ELCY	OVER DAM	CPB	OUTFLOW	HOURS
1.00	775.00	200	9.00	15.78	0.80







1.01	4.98	86	.01	.01	1.01	17.18	207	.23	.00	59
1.01	4.95	87	.01	.01	1.01	17.15	207	.23	.00	59
1.01	4.92	88	.01	.01	1.01	17.12	208	.23	.00	59
1.01	4.89	89	.01	.01	1.01	17.09	209	.23	.00	59
1.01	4.86	90	.01	.01	1.01	17.06	210	.23	.00	59
1.01	4.83	91	.01	.01	1.01	17.03	211	.23	.00	59
1.01	4.80	92	.01	.01	1.01	17.00	212	.23	.00	59
1.01	4.77	93	.01	.01	1.01	16.97	213	.23	.00	59
1.01	4.74	94	.01	.01	1.01	16.94	214	.23	.00	59
1.01	4.71	95	.01	.01	1.01	16.91	215	.23	.00	59
1.01	4.68	96	.01	.01	1.01	16.88	216	.23	.00	59
1.01	4.65	97	.01	.01	1.01	16.85	217	.23	.00	59
1.01	4.62	98	.01	.01	1.01	16.82	218	.23	.00	59
1.01	4.59	99	.01	.01	1.01	16.79	219	.23	.00	59
1.01	4.56	100	.01	.01	1.01	16.76	220	.23	.00	59
1.01	4.53	101	.01	.01	1.01	16.73	221	.23	.00	59
1.01	4.50	102	.01	.01	1.01	16.70	222	.23	.00	59
1.01	4.47	103	.01	.01	1.01	16.67	223	.23	.00	59
1.01	4.44	104	.01	.01	1.01	16.64	224	.23	.00	59
1.01	4.41	105	.01	.01	1.01	16.61	225	.23	.00	59
1.01	4.38	106	.01	.01	1.01	16.58	226	.23	.00	59
1.01	4.35	107	.01	.01	1.01	16.55	227	.23	.00	59
1.01	4.32	108	.01	.01	1.01	16.52	228	.23	.00	59
1.01	4.29	109	.01	.01	1.01	16.49	229	.23	.00	59
1.01	4.26	110	.01	.01	1.01	16.46	230	.23	.00	59
1.01	4.23	111	.01	.01	1.01	16.43	231	.23	.00	59
1.01	4.20	112	.01	.01	1.01	16.40	232	.23	.00	59
1.01	4.17	113	.01	.01	1.01	16.37	233	.23	.00	59
1.01	4.14	114	.01	.01	1.01	16.34	234	.23	.00	59
1.01	4.11	115	.01	.01	1.01	16.31	235	.23	.00	59
1.01	4.08	116	.01	.01	1.01	16.28	236	.23	.00	59
1.01	4.05	117	.01	.01	1.01	16.25	237	.23	.00	59
1.01	4.02	118	.01	.01	1.01	16.22	238	.23	.00	59
1.01	3.99	119	.01	.01	1.01	16.19	239	.23	.00	59
1.01	3.96	120	.01	.01	1.01	16.16	240	.23	.00	59
1.01	3.93	121	.01	.01	1.01	16.13	241	.23	.00	59
1.01	3.90	122	.01	.01	1.01	16.10	242	.23	.00	59
1.01	3.87	123	.01	.01	1.01	16.07	243	.23	.00	59
1.01	3.84	124	.01	.01	1.01	16.04	244	.23	.00	59
1.01	3.81	125	.01	.01	1.01	16.01	245	.23	.00	59
1.01	3.78	126	.01	.01	1.01	15.98	246	.23	.00	59
1.01	3.75	127	.01	.01	1.01	15.95	247	.23	.00	59
1.01	3.72	128	.01	.01	1.01	15.92	248	.23	.00	59
1.01	3.69	129	.01	.01	1.01	15.89	249	.23	.00	59
1.01	3.66	130	.01	.01	1.01	15.86	250	.23	.00	59
1.01	3.63	131	.01	.01	1.01	15.83	251	.23	.00	59
1.01	3.60	132	.01	.01	1.01	15.80	252	.23	.00	59
1.01	3.57	133	.01	.01	1.01	15.77	253	.23	.00	59
1.01	3.54	134	.01	.01	1.01	15.74	254	.23	.00	59
1.01	3.51	135	.01	.01	1.01	15.71	255	.23	.00	59
1.01	3.48	136	.01	.01	1.01	15.68	256	.23	.00	59
1.01	3.45	137	.01	.01	1.01	15.65	257	.23	.00	59
1.01	3.42	138	.01	.01	1.01	15.62	258	.23	.00	59
1.01	3.39	139	.01	.01	1.01	15.59	259	.23	.00	59
1.01	3.36	140	.01	.01	1.01	15.56	260	.23	.00	59
1.01	3.33	141	.01	.01	1.01	15.53	261	.23	.00	59
1.01	3.30	142	.01	.01	1.01	15.50	262	.23	.00	59
1.01	3.27	143	.01	.01	1.01	15.47	263	.23	.00	59
1.01	3.24	144	.01	.01	1.01	15.44	264	.23	.00	59
1.01	3.21	145	.01	.01	1.01	15.41	265	.23	.00	59
1.01	3.18	146	.01	.01	1.01	15.38	266	.23	.00	59
1.01	3.15	147	.01	.01	1.01	15.35	267	.23	.00	59
1.01	3.12	148	.01	.01	1.01	15.32	268	.23	.00	59
1.01	3.09	149	.01	.01	1.01	15.29	269	.23	.00	59
1.01	3.06	150	.01	.01	1.01	15.26	270	.23	.00	59
1.01	3.03	151	.01	.01	1.01	15.23	271	.23	.00	59
1.01	3.00	152	.01	.01	1.01	15.20	272	.23	.00	59
1.01	2.97	153	.01	.01	1.01	15.17	273	.23	.00	59
1.01	2.94	154	.01	.01	1.01	15.14	274	.23	.00	59
1.01	2.91	155	.01	.01	1.01	15.11	275	.23	.00	59
1.01	2.88	156	.01	.01	1.01	15.08	276	.23	.00	59
1.01	2.85	157	.01	.01	1.01	15.05	277	.23	.00	59
1.01	2.82	158	.01	.01	1.01	15.02	278	.23	.00	59
1.01	2.79	159	.01	.01	1.01	14.99	279	.23	.00	59
1.01	2.76	160	.01	.01	1.01	14.96	280	.23	.00	59
1.01	2.73	161	.01	.01	1.01	14.93	281	.23	.00	59
1.01	2.70	162	.01	.01	1.01	14.90	282	.23	.00	59
1.01	2.67	163	.01	.01	1.01	14.87	283	.23	.00	59
1.01	2.64	164	.01	.01	1.01	14.84	284	.23	.00	59
1.01	2.61	165	.01	.01	1.01	14.81	285	.23	.00	59
1.01	2.58	166	.01	.01	1.01	14.78	286	.23	.00	59
1.01	2.55	167	.01	.01	1.01	14.75	287	.23	.00	59
1.01	2.52	168	.01	.01	1.01	14.72	288	.23	.00	59
1.01	2.49	169	.01	.01	1.01	14.69	289	.23	.00	59
1.01	2.46	170	.01	.01	1.01	14.66	290	.23	.00	59
1.01	2.43	171	.01	.01	1.01	14.63	291	.23	.00	59
1.01	2.40	172	.01	.01	1.01	14.60	292	.23	.00	59
1.01	2.37	173	.01	.01	1.01	14.57	293	.23	.00	59
1.01	2.34	174	.01	.01	1.01	14.54	294	.23	.00	59
1.01	2.31	175	.01	.01	1.01	14.51	295	.23	.00	59
1.01	2.28	176	.01	.01	1.01	14.48	296	.23	.00	59
1.01	2.25	177	.01	.01	1.01	14.45	297	.23	.00	59
1.01	2.22	178	.01	.01	1.01	14.42	298	.23	.00	59
1.01	2.19	179	.01	.01	1.01	14.39	299	.23	.00	59
1.01	2.16	180	.01	.01	1.01	14.36	300	.23	.00	59
1.01	2.13	181	.01	.01	1.01	14.33	301	.23	.00	59
1.01	2.10	182	.01	.01	1.01	14.30	302	.23	.00	59
1.01	2.07	183	.01	.01	1.01	14.27	303	.23	.00	59
1.01	2.04	184	.01	.01	1.01	14.24	304	.23	.00	59
1.01	2.01	185	.01	.01	1.01	14.21	305	.23	.00	59
1.01	1.98	186	.01	.01	1.01	14.18	306	.23	.00	59
1.01	1.95	187	.01	.01	1.01	14.15	307	.23	.00	59
1.01	1.92	188	.01	.01	1.01	14.12	308	.23	.00	59
1.01	1.89	189	.01	.01	1.01	14.09	309	.23	.00	59
1.01	1.86	190	.01	.01	1.01	14.06	310	.23	.00	59
1.01	1.83	191	.01	.01	1.01	14.03	311	.23	.00	59
1.01	1.80	192	.01	.01	1.01	14.00	312	.23	.00	59
1.01	1.77	193	.01	.01	1.01	13.97	313	.23	.00	59
1.01	1.74	194	.01	.01	1.01	13.94	314	.23	.00	59
1.01	1.71	195	.01	.01	1.01	13.91	315	.23	.00	59
1.01	1.68	196	.01	.01	1.01	13.88	316	.23	.00	59
1.01	1.65	197	.01	.01	1.01	13.85	317	.23	.00	59
1.01	1.62	198	.01	.01	1.01	13.82	318	.23	.00	59
1.01	1.59	199	.01	.01	1.01	13.79	319	.23	.00	59
1.01	1.56	200	.01	.01	1.01	13.76	320	.23	.00	59
1.01	1.53	201	.01	.01	1.01	13.73	321	.23	.00	59
1.01	1.50	202	.01	.01	1.01	13.70	322	.23	.00	59
1.01	1.47	203	.01	.01	1.01	13.67	323	.23	.00	59
1.01	1.44	204	.01	.01	1.01	13.64	324	.23	.00	59
1.01	1.41	205	.01	.01	1.01	13.61	325	.23	.00	59
1.01	1.38	206	.01	.01	1.01	13.58	326	.23	.00	59
1.01	1.35	207	.01	.01	1.01	13.55	327	.23	.00	59
1.01	1.32	208	.01	.01	1.01	13.52	328	.23	.00	59
1.01	1.29	209	.01	.01	1.01	13.49	329	.23	.00	59
1.01	1.26	210	.01	.01	1.01	13.46	330	.23	.00	59
1.01	1.23	211	.01	.01	1.01	13.43	331	.23	.00	59
1.01	1.20	212	.01	.01	1.01	13.40	332	.23	.00	59
1.01	1.17	213	.01	.01	1.01	13.37	333	.23	.00	59
1.01	1.14	214	.01	.01	1.01	13.34	334	.23	.00	59
1.01	1.11	215	.01	.01	1.01	13.31	335	.23	.00	59
1.01	1.08	216	.01	.01	1.01	13.28	336	.23	.00	59
1.01	1.05	217	.01	.01	1.01	13.25	337	.23	.00	59
1.01	1.02	218	.01	.01	1.01	13.22	338	.23	.00	





PEAK FLOW AND STORAGE (END OF PERIOD) SUMMARY FOR MULTIPLE PLAN-RATIO ECONOMIC COMPUTATIONS  
 FLOWS IN CUBIC FEET PER SECOND (CUBIC METERS PER SECOND)  
 AREA IN SQUARE MILES (SQUARE KILOMETERS)

RATIOS APPLIED TO FLOWS

OPERATION STATION AREA PLAN RATIO 1

HYDROGRAPH AT 011113 .03 294.  
 .093 8.3911

ROUTED TO 011173 .03 3.  
 .093 .1071

SUMMARY OF DAM SAFETY ANALYSIS

PLAN 1 .....	INITIAL VALUE	SPILLWAY CREST	TOP OF DAM
	ELEVATION	760.00	775.00
	STORAGE	15.	45.
	OUTFLOW	0.	0.
RATIO	MAXIMUM	MAXIMUM	TIME OF
OF	RESERVOIR	STORAGE	MAX OUTFLOW
PHRE	DEPTH	AC-PT	HOURS
	OVER DAM		HOURS
1.00	0.00	40.	18.17
		3.	0.00

.....  
 FLOOD HYDROGRAPH PACKAGE (HEC-1)  
 QM SAFETY VERSION JULY 1978  
 LAST MODIFICATION 26 FEB 79  
 .....

RUN DATE: 80/07/88  
 TIME: 15.09.36

DAM SAFETY INSPECTION MISSOURI  
 MOORE LAKE DAM #10 (1173)  
 PERCENT PMP

JOB SPECIFICATION

NO	MNR	MHIN	IDAY	IHR	IMIN	METRC	IPLT	IPRT	INSTAN
0	0	0	0	0	0	0	0	0	0
0	0	0	0	0	0	0	0	0	0
0	0	0	0	0	0	0	0	0	0
0	0	0	0	0	0	0	0	0	0

MULTI-PLAN ANALYSES TO BE PERFORMED

MPLAN= 1 NRATIO= 6 LATIO= 1

RTIOS= .30 .40 .45 .50 .55 .60

SUB-AREA RUNOFF COMPUTATION

INPUT PRECIPITATION INDEX, RATIOS, AND UNIT HYDROGRAPH PARAMETERS

ISTAG	ICOMP	IECON	ITAPE	JFLT	JPRT	INAME	ISTAGE	IAUTO
01173	0	0	0	0	0	1	0	0

HYDROGRAPH DATA

HYDRO	IUNG	TAREA	SNAP	TRSDA	TRSPC	RATIO	ISNOV	ISAME	LOCAL
1	2	.03	0.00	.03	1.00	0.000	0	1	0

PRECIP DATA

SPEE	PMS	R4	R12	R24	R48	R72	R96
0.00	24.80	400.00	120.00	130.00	0.00	0.00	0.00

LOSS DATA

LAORT	STRNG	DLTMR	RTIOL	ERAIN	STRKS	RTIOK	STRYL	CNSTL	ALSMX	RTIMP
0	0.00	0.00	1.00	0.00	0.00	1.00	-1.00	-92.00	0.00	0.00

CURVE NO = 792.00 WETNESS = 51.00 EFFECT CN = 92.00

UNIT HYDROGRAPH DATA

TCR 0.00 LAGE .03

RECESSION DATA

SIRTSO 0.00 ORCSM 0.00 RTIOR= 1.00

END-OF-PERIOD FLOW

MO-DA	HR-MN	PERIOD	RAIN	LACS	LOSS	COMP	MO-DA	HR-MN	PERIOD	RAIN	EXCS	LOSS	COMP
0	0	0	0	0	0	0	0	0	0	0	0	0	0

SUM 32-25 21-22 1-02 7952.  
 (812.16 793.31 26.31 225.18)

HYDROGRAPH ROUTING

ROUTE HYDROGRAPH THROUGH HOOPER'S LAKE DAM (NO 11178)

ISTAG ICOMP IFCOM IJTAG IJFT IJPT INAME ITRAGE IAUTO  
 01113 0 0 0 0 0 0 0 0

ROUTING DATA  
 IRES ISAME IOPT IPHP LSTR  
 0.0 0.00 0.00 0 0 0

MSIPS NSTDL LAG ANSKM K TSK BTORA ISPRAY  
 0 0 0.000 0.000 0.000 0.000 -1

STAGE	769.00	771.00	772.00	773.00	773.30	773.60	774.00	775.30	776.60
FLOW	2400	3.00	3.00	4.80	49.80	187.00	405.00	670.00	1095.00
AREA	3546.00	2057.00	3365.00						

PEAK OUTFLOW IS 3. AT TIME 15.50 HOURS

PEAK OUTFLOW IS 9. AT TIME 16.17 HOURS

PEAK OUTFLOW IS 21. AT TIME 16.00 HOURS

PEAK OUTFLOW IS 32. AT TIME 19.00 HOURS

TOPEL COOD ERPD DAMVID  
 773.0 0.0 0.0 0.

CREL SPNID COOL EXPH ELEVEL  
 769.0 0.0 0.0 0.0 0.0

CAREA EXPL  
 0.0 0.0

COOL ERPD DAMVID  
 0.0 0.0 0.0

PEAK OUTFLOW IS 3. AT TIME 15.50 HOURS

PEAK OUTFLOW IS 9. AT TIME 16.17 HOURS

PEAK OUTFLOW IS 21. AT TIME 16.00 HOURS

PEAK OUTFLOW IS 32. AT TIME 19.00 HOURS

PEAK FLOW AND STORAGE (END OF PERIOD) SUMMARY FOR MULTIPLE PLAN-RATIO ECONOMIC COMPUTATIONS  
 FLOWS IN CUBIC FEET PER SECOND (CUBIC METERS PER SECOND)  
 AREA IN SQUARE MILES (SQUARE KILOMETERS)

OPERATION	STATION	AREA	PLAN RATIO	RATIO 1	RATIO 2	RATIO 3	RATIO 4	RATIO 5	RATIO 6
HYDROGRAPH AT	011173	.03	.35	287	237	267	296	326	356
		.091	.40	6.861	6.721	7.651	8.391	9.231	10.071
ROUTED TO	011173	.03	.35	.087	.091	.101	.111	.21	.32
		.091	.40	.087	.091	.101	.111	.601	.911

SUMMARY OF DAM SAFETY ANALYSIS

RATIO OF PRE	MAXIMUM RESERVOIR U.S. LEV	MAXIMUM DEPTH OVER DAM	MAXIMUM STORAGE AC-FT	MAXIMUM OUTFLOW CFS	DURATION OVER TOP HOURS	TIME OF MAX OUTFLOW HOURS	TIME OF FAILURE HOURS	SPILLWAY CREST	
								ELEVATION	TOP OF DAM
.25	771.88	0.00	37	3	0.00	15.50	0.00	770.00	775.00
.50	772.29	0.00	39	3	0.00	18.17	0.00	769.00	775.00
.75	772.60	0.00	42	4	0.00	18.17	0.00	769.00	775.00
.90	772.90	0.00	44	4	0.00	18.17	0.00	769.00	775.00
.95	773.12	0.18	46	21	2.78	18.00	0.00	769.00	775.00
1.00	773.17	0.19	47	32	4.00	18.00	0.00	769.00	775.00

END

DATE  
FILMED

10-81

DTIC