

AD-A105 027

POLYTECHNIC INST OF NEW YORK BROOKLYN
INTERACTION OF ELECTROMAGNETIC FIELDS WITH PLASMA. (U)
SEP 80 B R CHEO; S P KUO

F/6 20/9

UNCLASSIFIED

AFOSR-TR-81-0620

AFOSR-79-0009

NL

For
403
10/077



END
DATE
FILMED
10-81
DTIC

AFOSR-TR-81-0620

(S)

AD A105027

TECHNICAL PROGRESS REPORT
AIR FORCE OFFICE OF SCIENTIFIC RESEARCH
INTERACTION OF ELECTROMAGNETIC FIELDS WITH PLASMA
(Grant AFOSR-79-0009)

Period Starting: October 1, 1979

Period Ending: September 1, 1980

Bernard R. Cheo, Professor - Principal Investigator

S.P. Kuo, Research Assistant Professor - Co-Principal Investigator

POLYTECHNIC INSTITUTE OF NEW YORK

DTIC FILE COPY

RECEIVED
OCT 6 1981
A

Approved for public release;
distribution unlimited.

II. PROGRESS REPORT AND WORK TO BE CONTINUED

1) Imploding Tube Experiment: Project is finished. A technical report is issued: (Charles D. Hechtman and B.R. Cheo, "Investigation of Electrically Exploding Thin Shelled Metallic Tubes," Scientific Report No. POLY-EE-80-007, October, 1980).

2) Harmonic Generation: Project is completed. A technical report is issued:

3) Wave-Particle Interaction at Cyclotron Resonance

The motion of charged particles in a d.c. magnetic field and an rf wave is governed by a set of coupled nonlinear differential equations

$$\frac{d}{dt} \vec{r}(t) = \vec{v}(t) \quad (3.1)$$

$$\frac{d}{dt} \vec{v}(t) = \frac{q}{m} (\vec{E}[\vec{r}(t), t]) + [\vec{v}(t)/c] \times \{\vec{B}[\vec{r}(t), t] + \vec{B}_0[r(t)]\} \quad (3.2)$$

which are not subject to easy solutions in general, where $\vec{E}(\vec{r}, t)$ and $\vec{B}(\vec{r}, t)$ are the oscillating fields of the EM wave and $\vec{B}_0(\vec{r})$ is the background dc magnetic field.

However, the usual simplifications, such as ignoring the perturbation in the trajectories used in the integration of the equations of motion and neglecting the oscillating magnetic field of the rf wave can lead to significant errors at cyclotron resonances. This conclusion is manifested in the previous report [Kuo and Cheo, to be published] which used a self-consistent resonant trajectory to integrate the equations of motion, (3.1) and (3.2), and found that there is significant perpendicular heating and no parallel heating by using ordinarily polarized wave fields. The temporal evolutions of the

distribution functions and perpendicular temperature are also obtained in the previous works for a simple plasma model, i.e., uniform background magnetic field and normally incident EM wave [Kuo and Cheo, 1980].

In the presently proposed program, electron cyclotron resonance heating in a mirror magnetic field will be investigated. It will enable us to have direct comparison between our theoretical results and the experimental observations of others. The bounding effect of the trapped electrons in the mirror field on the resonance heating will be investigated. The preliminary results [Kuo and Cheo, 1981] have shown that the trapping effect of electrons by the mirror field is indeed important to the resonance heating. It is because the phase variation of the wave seen by the trapped electrons becomes bounded due to the finite excursion, all the trapped electrons can receive resonant interaction with the heating wave at a frequency equal to either the fundamental or harmonics of the mid-plane cyclotron frequency. The arising of the additional resonant interaction without experiencing mis-match between wave and electrons in such inhomogeneous magnetic field and arbitrary incident angles can be understood from the fact that electrons are bouncing back and forth in the mirror field. Wave-electron interactions are thus Doppler shifted by the integer multiples of the bouncing frequency and one component always contributes to the resonance interaction without mismatch. The perpendicular heating rate and the effect heating wave upon the confinement of the electrons will be determined. It is also our plan to derive the adiabatic invariant relations of motion under the resonance conditions for various mode type of heating waves [Kuo et al., 1981]. The results of the study may provide information about the

saturation level of the heating. Other possible mechanisms such as relativistic effect and syndiotron radiation will also be investigated.

4) Turbulent Interaction Between Waves and Charged Particles

The problem of turbulent heating of plasma by laser fields through parametric excitation is investigated. The main objective of this investigation is to understand the heating profile in the velocity space of electrons in order to predict and also to verify the experimental observations, i.e., when and how the suprathermal electrons will be produced and how much heating energy will be deposited into the main body of the plasma electrons. In previous analyses [Kuo and Cheo, to be published], the ratio $\gamma_B(0)/\gamma_T(0)$ of the initial energy deposition rates to the bulk electrons and to the suprathermal tail electrons was determined. It was found that bulk heating can dominate over tail heating when the pump field is sufficiently strong $E_0 \geq (4\pi n_0 T_e)^{1/2}$.

It is known that the wave particle interactions become more effective than the result of conventional quasi-linear diffusion when the turbulence level increases. This is because the orbit of the charged particle is constantly perturbed by the turbulent wave fields and hence the resonant interaction between waves and particles are broadened. If the turbulence is parametrically excited by a coherent pump, as considered in the present analysis, the particle orbit is also perturbed by the pump field in addition to the turbulent fields. The oscillation of the particle due to the pump field will also broaden the interaction with the turbulent fields. This is due to the fact that the phase velocity of the turbulent waves as viewed by the oscillating particles is Doppler shifted by integral multiples of ω_0/k , where ω_0 is

the pump frequency and k is the wavenumber of the turbulent field. Therefore, the parametrically excited electron plasma wave does interact with those bulk electrons effectively. Moreover, the production of electrons at several phase speeds of the electron plasma waves is also predicted.

The results of the previous analysis is preliminary in the sense that only the ratio of initial energy deposition rates is determined, and also the case of $E_0^2/4\pi n_0 T_e \gg 1$ so that the possibility of the production of ultra-suprathermal electron to the anomalous level is not considered.

In the present investigation, temporal evolution of the ratio of energy deposition rates to the bulk electrons and to the suprathermal and ultra-suprathermal tail electrons will be derived. The dependence of the level of the produced ultra-suprathermal electrons on the pump power will be determined and the effects of the inhomogeneity and the self-generated dc magnetic field in the background plasma on the present energy coupling mechanism will also be studied.

5) RF Driven DC Current Experiment

Two models of rf driven dc currents have been investigated. The first includes collisional effects based on momentum conservation. This technique yields the following dc electron and ion velocities

$$v_e = \frac{1}{2} \frac{k_{\perp} e^2}{m_e^2 \Omega_e^2} E^2 \tau_e \quad (5.1)$$

$$v_i = - \frac{1}{2} \frac{k_{\parallel} e^2}{m_i^2 \omega^2} E^2 \tau_i \quad (5.2)$$

The resultant dc current density is given by

$$J = \frac{e n_0 \omega}{4\sqrt{\pi} k_{\parallel}} \left(\frac{B}{B_0} \right)^2 \left[\frac{\omega}{\sqrt{\pi} v_e} + \frac{\Omega_i^2}{\sqrt{\pi} \omega v_i} \right] \quad (5.3)$$

The second model is based on retaining the second order $\underline{v}_1 \times \underline{B}_1$ term in the equations of motion.

The dc current density in this case is given by

$$J = \frac{e n_0 \omega}{4\sqrt{\pi} k_{\parallel}} \left(\frac{B}{B_0} \right)^2 \left[1 + \frac{\Omega_i}{\omega} \right]^2 \quad (5.4)$$

Equations (5.3) and (5.4) are valid in the frequency range,

$$\Omega_i \ll \omega \ll \Omega_e \quad (5.5)$$

The equations are valid for electromagnetic waves propagating in the z-direction where

$$\omega = \omega(k) \quad (5.6)$$

is determined by the dispersion relation of the specific mode. The details of the above results were presented in detail in the previous proposal.

Since the previous proposal, emphasis has been placed on the completion and testing of experimental facilities and the design of the wave launching structure. A summary of the experimental program is given below.

a) Wave Launching Structure for Alfvén Wave.

The problem is to design a wave launching structure that will excite an Alfvén wave propagating along the background magnetic field B_0 . The wave will be coupled magnetically to the plasma by means of an artificial transmission line. Magnetic coupling is used

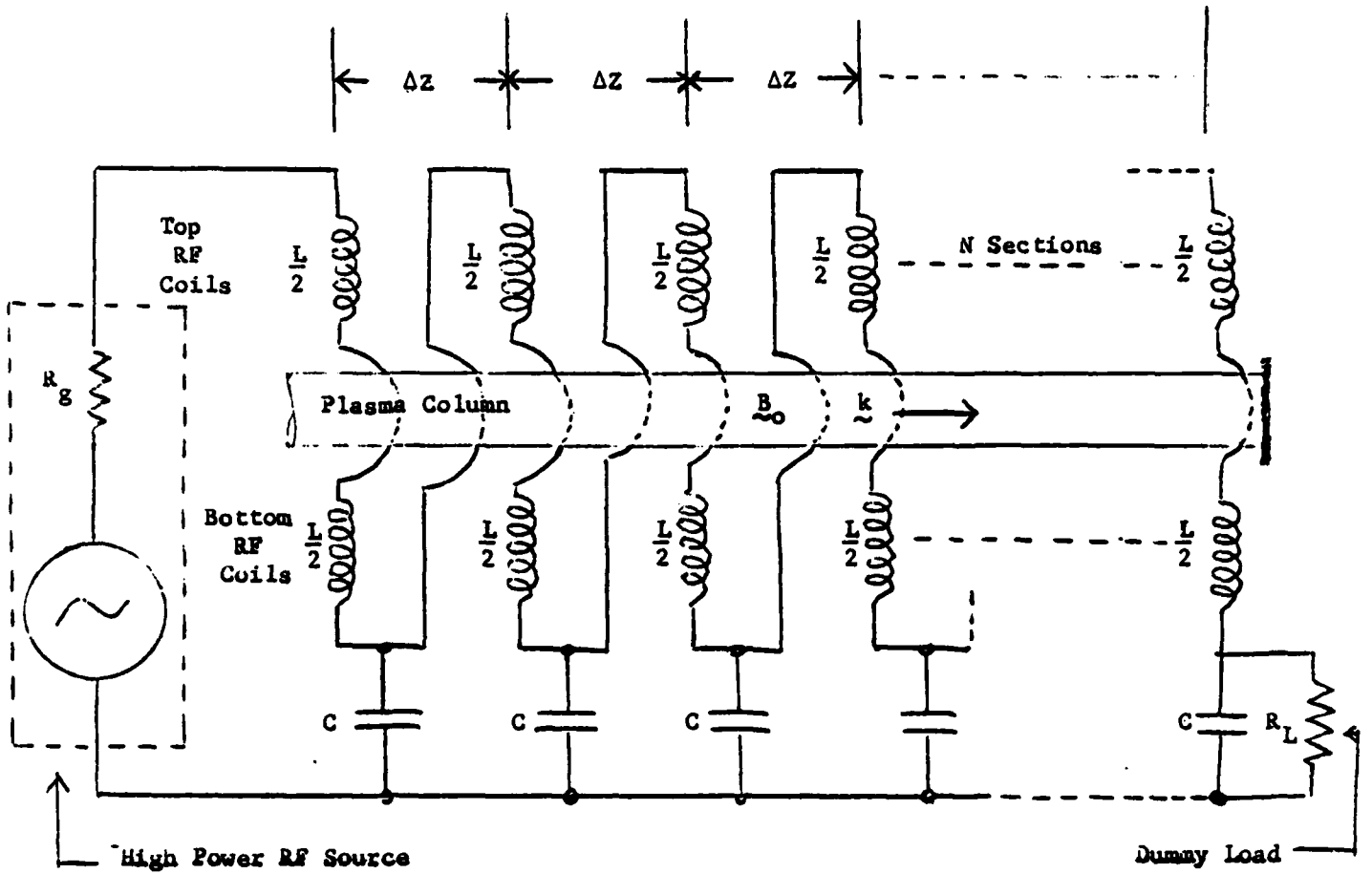

Figure 5.1 - Pictorial Diagram of Artificial Transmission Line

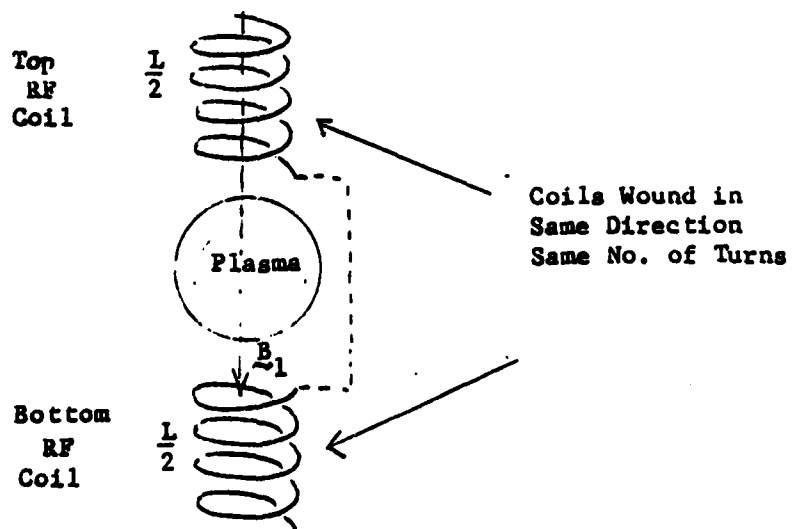

Figure 5.2 - RF Coil Configuration, End View

since the Alfvén wave possesses a low wave impedance; i.e., the wave phase speed is much less than c .

Basically the structure will be constructed as shown in Figures (5.1) and (5.2).

Figure 5.3 shows an equivalent network for the artificial transmission line.

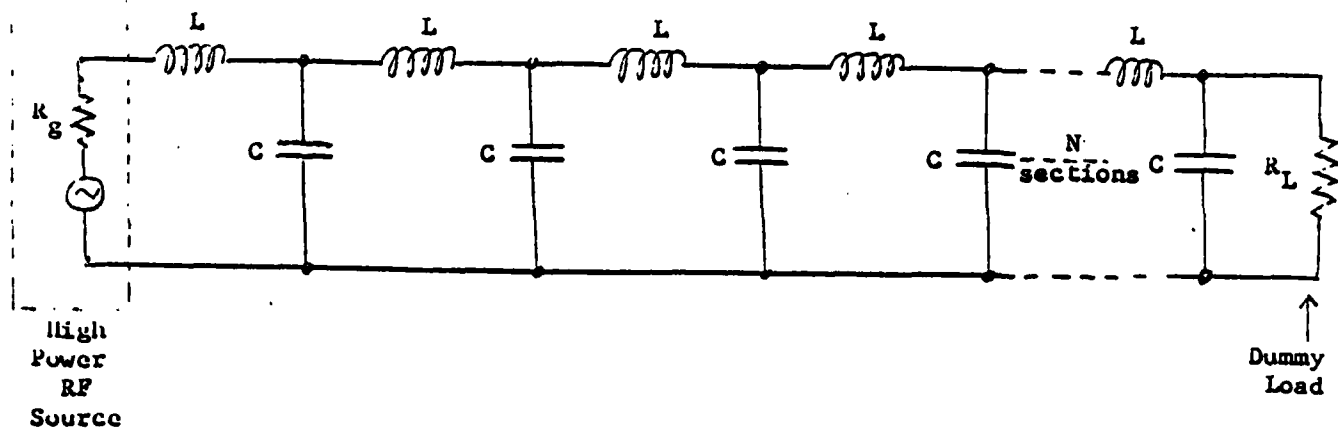

Figure 5.3 - Network Representation of Artificial Transmission Line

A summary of pertinent design considerations will not be discussed.

The dispersion relation for an Alfvén wave is given by

$$v_A = \frac{\omega}{k} = \frac{B_0}{\sqrt{\mu_0 n_0 m_i}} \quad (5.7)$$

$$k = \frac{2\pi}{\lambda} \quad (5.8)$$

where B_0 is the dc background magnetic field and n_0 is the ion density.

We see from (5.7) that for a given background magnetic field and gas, that the only experimental variable is n_0 and ω . These

parameters must be chosen with some care so as to make the experiment feasible. Considering the second theoretical model, equation (5.4) was the resultant dc current density. Inserting Eq. (5.7) into Eq. (5.4) yields the following expression for dc current density.

$$J = \frac{e^2 n_0}{16\pi \mu_0 m_i} 1/2 \left(\frac{B}{B_0} \right)^2 \quad (5.9)$$

The dc current density can be maximized by making n_0 as large as experimentally possible. However, for a fixed ω , the wavelength of the Alfvén wave becomes smaller.

It is not desirable to have the wavelength become so small that the construction of the artificial transmission line will become unreasonable.

The first step in the design is to determine the values of the network parameters L , C , and R_L . R_g is the internal impedance of the rf source. We desire to simulate a slow traveling wave on the artificial transmission line so as to couple quasistatically to the Alfvén wave. The coupling is obtained at the locations of the rf coils. The capacitors serve as delay elements so as to appropriately adjust the phase of the signal at various points in the network. If the phasing is adjusted so that the time phase delay Δt between adjacent coils is equal to the time it takes the Alfvén wave to propagate a distance Δz we will have a maximum coupling. The impedance of the transmission line is

$$Z_0 = \sqrt{\frac{L/\Delta z}{C/\Delta z}} = \sqrt{\frac{L}{C}} \quad (5.10)$$

To eliminate reflections and to have maximum power transfer from the high power rf source we set

$$Z_0 = R_L = R_g \quad (5.11)$$

This prevents a standing wave from being set up on the transmission line. Since R_g and R_L are fixed by the available equipment Z_0 is known and an equation involving L and C is given by (5.10). The phase velocity on a transmission line is given by

$$v_p = \frac{1}{\sqrt{\frac{L}{\Delta z} \frac{C}{\Delta z}}} = \frac{\Delta z}{\sqrt{LC}} \quad (5.12)$$

$$v_p = \frac{\omega}{k} = f\lambda = \frac{\Delta z}{\sqrt{LC}} \quad (5.13)$$

Δz is relatively arbitrary except that it must be chosen as a realistic number in terms of the experimental setup. Once the network parameters L and C are determined one can determine the currents through the inductors L and hence the generated rf magnetic field for a given input power.

The next step in the design makes use of dispersion relation (5.7) given a relationship between ω , λ , and n_0 . For a given density the value of the rf magnetic field, B will determine the dc current density. B will be determined by the rf current flowing in the rf coupling coils of a given geometry.

b) RF System

Presently, two relatively high power rf generators will be available for experiments. The first was described in a previous report. This unit is capable of delivering cw rf power of 1kW from 15MHz-

50MHz. It consists of basically three amplifiers. The first stage is a low power class A solid state driving amplifier of approximately 3W output. The second stage amplifier is a class B solid state amplifier capable of delivering 140W output at full drive power. The last stage is a class C grounded grid amplifier, tunable from 10MHz-50MHz capable of delivering 1KW CW with full drive power of approximately 75W.

The second high power rf source is a tunable 5KW CW oscillator operating in a frequency range from 2MHz-18MHz. It contains the appropriate audio drivers and modulators to operate the unit as modulated continuous wave (MCW), if desired. It can also be operated CW.

c) Pulse Modulator

To increase the ion density range of the experiment, a high power pulse modulator has been developed. This unit was described in the last proposal. The unit is capable of delivering peak powers of 32 MW; 16KV @ 2KA pulses. The average power capability has been upgraded from approximately 8KW to 16KW.

The new unit can operate up to a repetition rate of 500 Hz with a pulse width of approximately 1 μ s, using a line type modulator and a hydrogen thyratron as the switch tube.

d) Experiments

After the artificial transmission line is installed, experiments will proceed in the following manner.

The plasma will be generated by ECRH using 1KW CW microwaves at 2.45GHz. The rf units and plasma parameters will be adjusted to produce a dc current flow. The steady state background density n_0

is relatively low and hence limits the maximum allowable dc current flow.

The S band microwaves cannot produce a high density plasma since the plasma tends to screen out additional microwave power when the plasma density increases to a value where the corresponding plasma frequency is equal to the source frequency of 2.45GHz. This critical density corresponds to $7.4 \times 10^{10} \text{ cm}^{-3}$. This density appears in the vicinity of the microwave coupler, and in fact the density is significantly lower in the test region; 10^9 cm^{-3} . To investigate higher dc currents a method to enhance the density must be developed. To do this the 32MW pulse modulator will be used to enhance the density. The method used to carry out this experiment is as follows. A steady state plasma is produced using ECRH with the S-band microwave system. A pulsed longitudinal discharge is initiated with the pulse modulator. This ionizing high current pulse produces a high density plasma afterglow which decays to its steady state density in a few collision times.

If the rf drive is on during the entire experiment, a dc pulse current due to the rf drive will be produced at a point where the density n_0 is such that the Alfvén wave dispersion relation is satisfied. See Figures (5.4)-(5.7).

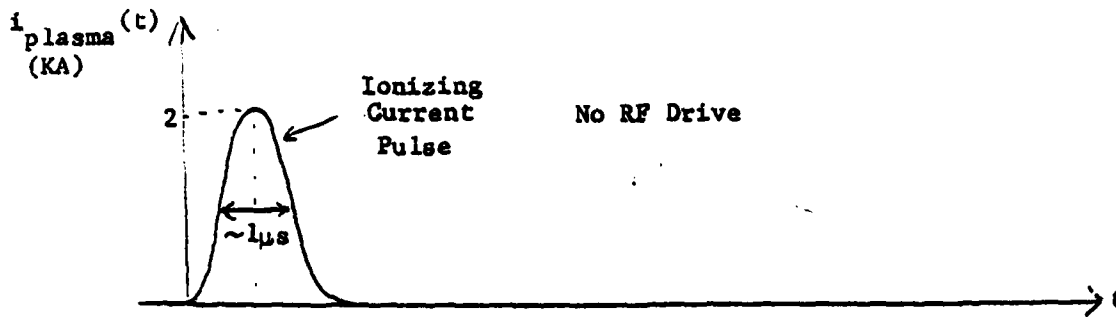

Figure 5.4 - Plasma Current, No RF Drive

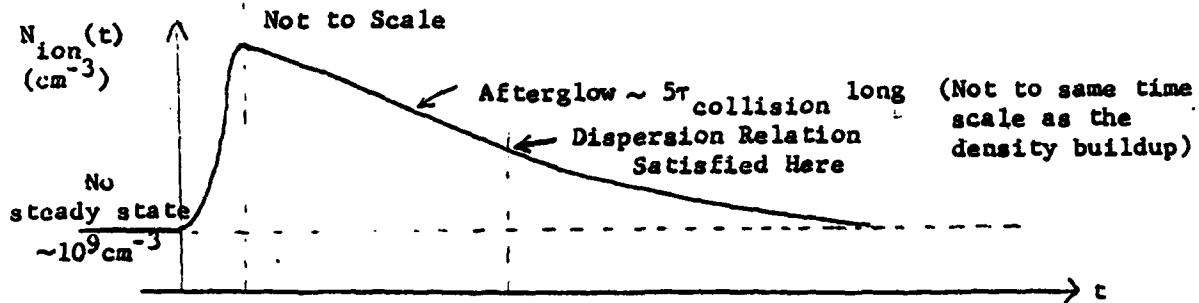

Figure 5.5 - Plasma Ion Density

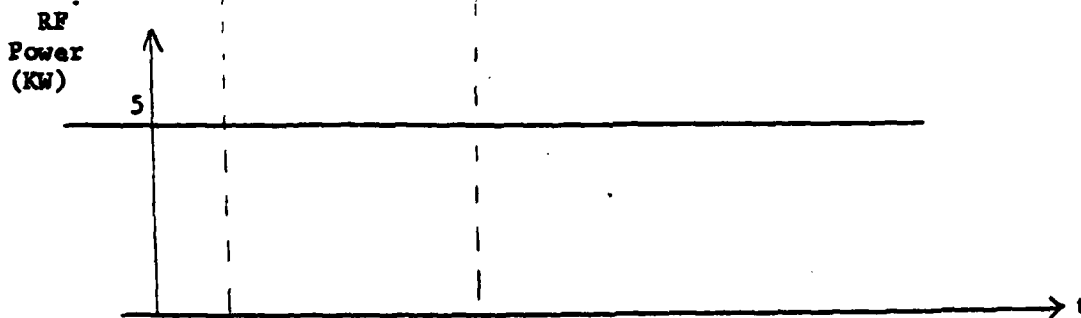

Figure 5.6 - RF Power Input

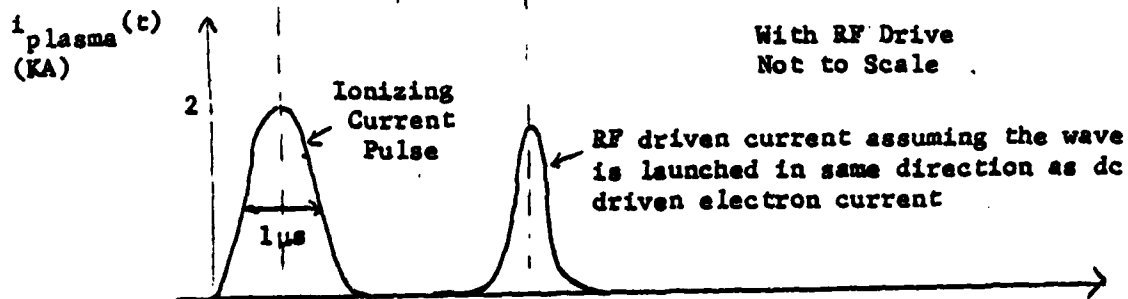

Figure 5.7 - Plasma Current, with RF Drive

REPORT DOCUMENTATION PAGE		READ INSTRUCTIONS BEFORE COMPLETING FORM
1. REPORT NUMBER AFOSR-TR- 81 - 0620	2. GOVT ACCESSION NO. <i>AD-A105027</i>	3. RECIPIENT'S CATALOG NUMBER
4. TITLE (and Subtitle) INTERACTION OF ELECTROMAGNETIC FIELDS WITH PLASMA		5. TYPE OF REPORT & PERIOD COVERED Interim
7. AUTHOR(s) Bernard R. Cheo		6. PERFORMING ORG. REPORT NUMBER
9. PERFORMING ORGANIZATION NAME AND ADDRESS <i>Polytechnic Inst. of New York</i>		8. CONTRACT OR GRANT NUMBER(s) AFOSR-79-0009
11. CONTROLLING OFFICE NAME AND ADDRESS AFOSR/NP Bolling AFB, Bldg. #410 Wash DC 20332		10. PROGRAM ELEMENT, PROJECT, TASK AREA & WORK UNIT NUMBERS 61102F 2301/A8
14. MONITORING AGENCY NAME & ADDRESS (if different from Controlling Office)		12. REPORT DATE 1 Oct 79 - 1 Sep 80
		13. NUMBER OF PAGES 13
		15. SECURITY CLASS. (of this report) UNCLASSIFIED
		15a. DECLASSIFICATION/DOWNGRADING SCHEDULE
16. DISTRIBUTION STATEMENT (of this Report) Approved for public release; distribution unlimited.		
17. DISTRIBUTION STATEMENT (of the abstract entered in Block 20, if different from Report)		
18. SUPPLEMENTARY NOTES		
19. KEY WORDS (Continue on reverse side if necessary and identify by block number)		
20. ABSTRACT (Continue on reverse side if necessary and identify by block number) Several topics under the general title of the progress report were investigated during the time period from Oct. 1, 1979 to Sept. 31, 1980. Essentially five topics have been studied during this time period; three are essentially experimental investigations, and the other two are theoretical. The five topics include. 1. Propagation of microwaves along a plasma column and harmonic generation of electrostatic ion cyclotron waves, 2. Imploding tube experiment, 3. Low frequency CW (Hz) rf (1MHz-10MHz) driven dc plasma current, 4. Wave-particle interaction at cyclotron resonance, and 5. turbulent		

interaction between waves and charged particle. Topics 1)-3) comprise the experimental investigations while the last two topics are theoretical in nature.

unclassified