

AD-A105 053

NAVAL RESEARCH LAB WASHINGTON DC
PRELIMINARY EVALUATION OF ION IMPLANTATION AS A SURFACE TREATME--ETC(U)
SEP 61 F A SMIDT, J K MIRVONEN, S RAMALINGAM

F/8 13/9

UNCLASSIFIED

NRL-MR-4616

MI

101
A
A05074



AMM HHH
HHH HHH



END
DATE
FILMED
11-811
DTIC

AD A 105053

SECURITY CLASSIFICATION OF THIS PAGE (When Data Entered)

REPORT DOCUMENTATION PAGE		READ INSTRUCTIONS BEFORE COMPLETING FORM
1. REPORT NUMBER NRL Memorandum Report 4616	2. GOVT ACCESSION NO. AD-A105053	3. RECIPIENT'S CATALOG NUMBER 14/NCL-RT-4616
4. TITLE (and Subtitle) PRELIMINARY EVALUATION OF ION IMPLANTATION AS A SURFACE TREATMENT TO REDUCE WEAR OF TOOL BITS.	5. TYPE OF REPORT & PERIOD COVERED Interim report on a continuing NRL problem.	
7. AUTHOR(s) F.A. Smidt, J.K. Hirvonen S. Ramalingam	6. PERFORMING ORG. REPORT NUMBER	
8. PERFORMING ORGANIZATION NAME AND ADDRESS Naval Research Laboratory Washington, DC 20375	9. CONTRACT OR GRANT NUMBER(s)	
11. CONTROLLING OFFICE NAME AND ADDRESS Office of Naval Research Arlington, VA 22217	10. PROGRAM ELEMENT, PROJECT, TASK AREA & WORK UNIT NUMBERS RR022-11-41 63-1314-01	
14. MONITORING AGENCY NAME & ADDRESS (if different from Controlling Office)	12. REPORT DATE September 1981	
	13. NUMBER OF PAGES 57	
	15. SECURITY CLASS. (of this report) UNCLASSIFIED	
	15a. DECLASSIFICATION/DOWNGRADING SCHEDULE	
16. DISTRIBUTION STATEMENT (of this Report) Approved for public release; distribution unlimited.		
17. DISTRIBUTION STATEMENT (of the abstract entered in Block 20, if different from Report)		
18. SUPPLEMENTARY NOTES *Present address: Georgia Institute of Technology, Atlanta, Georgia.		
19. KEY WORDS (Continue on reverse side if necessary and identify by block number) Ion implantation Wear Machine tool wear		
20. ABSTRACT (Continue on reverse side if necessary and identify by block number) The process of ion implantation is reviewed and concepts for use as a surface hardening technique for extending the life of machine tools are explored. It is concluded that for high speed steel tool materials a system based on implantation of Ti ions with subsequent reaction to form TiC in the surface layers should have merit. Exploratory tests showed that in machining tests of 4140 steel, an implanted M2 lathe tool bit required about 10 percent less power and has a wear rate approximately one-half that of the unimplanted tool. Tests of end mills proved inconclusive because the optimum Ti level for the implant was not reached.		

DD FORM 1473
1 JAN 73

EDITION OF 1 NOV 65 IS OBSOLETE
S/N 3102-014-6601

SECURITY CLASSIFICATION OF THIS PAGE (When Data Entered)

251100

BLANK PAGE

CONTENTS

I. INTRODUCTION	1
II. ION IMPLANTATION BACKGROUND	1
A. Characteristics of Ion Implantation	1
B. Historical Perspective	3
C. Ion Implantation — Advantages and Limitations of Technique	3
D. Ion Implantation Equipment and Costs	4
III. MAJOR FACTORS IN METAL REMOVAL OPERATIONS	9
A. Factors Affecting Tool Wear	9
B. Materials Selection and Processing for Wear Reduction	12
C. Cost Factors in Machining Operations	16
IV. SELECTION OF MATERIAL SYSTEM FOR EXPERIMENTAL EVALUATION OF WEAR REDUCTION IN MACHINE TOOLS	19
V. EXPERIMENTAL RESULTS	29
A. Ion Implantation	29
B. Instrumented Lathe Tests	30
C. Service Tests of Ion Implanted Tools	42
VI. CONCLUSIONS AND RECOMMENDATIONS	53
ACKNOWLEDGMENTS	53
REFERENCES	54

Accession For	
NTIS GRA&I	<input checked="" type="checkbox"/>
DTIC TAB	<input type="checkbox"/>
Unannounced	<input type="checkbox"/>
Justification	
By _____	
Distribution/	
Availability Codes	
Dist	Avail and/or Special
A	

S DTIC
ELECTE
OCT 6 1981
D

BLANK PAGE

PRELIMINARY EVALUATION OF ION IMPLANTATION AS A SURFACE TREATMENT TO REDUCE WEAR OF TOOL BITS

I. INTRODUCTION

Material removal operations are a major cost factor in manufacturing operations. It has been estimated that \$60 billion per year is spent on such operations in the United States alone [1]. Machining costs are also a major factor in the manufacture of ordnance systems such as missile launchers where machining costs may reach 30 to 35 percent of the total production cost of the system. The present study was commissioned to evaluate ion implantation as a possible approach to reducing tooling costs in the manufacturing process and, in the longer term, reduction of life cycle costs and improvement of reliability in critical system components.

Ion implantation has been demonstrated to be a versatile technique for the modification of surfaces without changing the properties of the bulk material and with no change in physical dimensions of the component [2]. Improvements in wear life by a factor of 6 to 10 times have been observed for metal forming tools, injection molds for plastics, and slitting knives for rubber in commercial applications in industry in the United Kingdom [3]. These applications, however, represent relatively low wear situations at low temperatures. The wear of metal cutting tools represents a much more rigorous application of ion implantations which had not previously been evaluated. The sponsor suggested that machining of AISI 4340 steel with high speed steel tool bits was an area of interest and the bulk of the work was addressed to this application with a minor survey of improvements in the performance of TiC-coated carbide tool bits.

This report contains a brief description of ion implantation, a review of metal removal operations, rationale for ion implantation surface modification, initial test results, and recommendations.

II. ION IMPLANTATION BACKGROUND

A. Characteristics of Ion Implantation

Ion implantation is a process by which virtually any element can be injected into the near-surface region of any solid by means of a beam of high-velocity ions, usually tens to hundreds of KeV in energy, striking a target mounted in a vacuum chamber. The incident ions come to a stop at depths of tens to thousands of angstroms (i.e., 0.001 to 0.1 μ m) in the host material as a result of losing energy during collisions with substrate atoms. The resulting depth concentration profile of implanted dopant atoms can be calculated for most projectile-target combinations from well established theoretical considerations. At low ion fluences (i.e., the number of ions per unit area), the depth concentration profiles are usually well characterized by a Gaussian distribution centered about an average range. An example of such a distribution is shown in Fig. 1. At higher fluences, other effects such as sputtering and ion beam induced migration of atoms can significantly alter or limit the ultimate depth concentrations attainable. During the slowing down process, the incident projectile

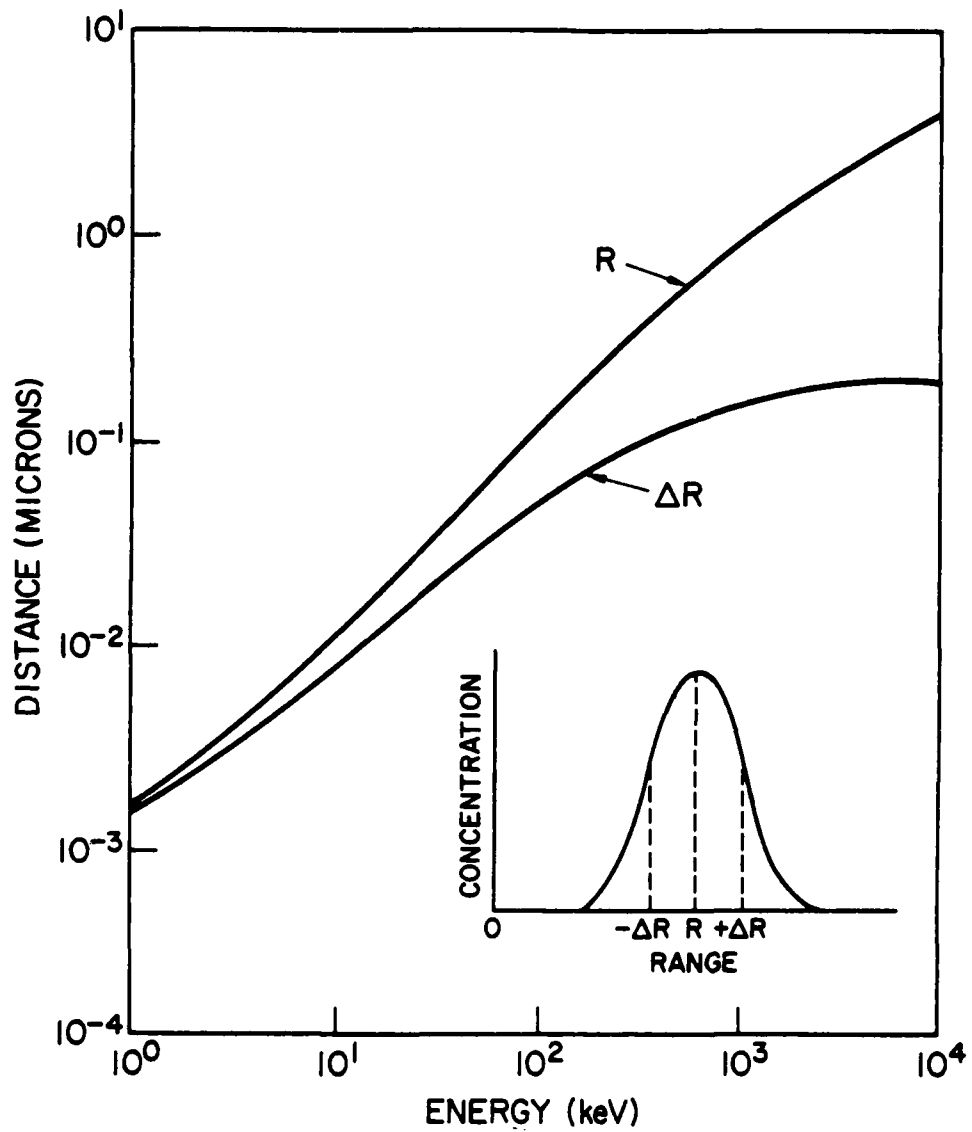

Fig. 1 — The projected range (R) and range straggling (ΔR) as a function of implantation energy for nitrogen in iron

ions transfer a significant amount of energy to the target atoms, resulting in the displacement of target atoms. There is a probability of atoms being ejected (sputtered) from the surface of the target as a result of such collisions, especially for heavier mass incident projectiles. Under these conditions, an equilibrium condition is eventually reached, where as many atoms are removed by sputtering as are replenished by implantation. The depth distribution of implanted atoms under this condition, has a maximum at the surface and falls off over a distance comparable to the initial range.

Because ion implantation is a process that modifies surface properties it is often compared with other conventional techniques, such as vacuum coating, chemical vapor deposition, and ion plating, which are all used for enhancing surface properties such as corrosion or wear resistance. It shares a number of advantages with these techniques but also has some basic limitation. These advantages and limitations are discussed in a later section. It is important to understand the differences between ion implantation and coating techniques especially ion plating. There are superficial similarities between the two techniques but they differ in many respects. The result of ion implantation into materials is the formation of a surface alloy of graded composition that possess no well defined interface with respect to the substrate, as does a deposited layer. The thickness of the implanted region is typically less than 1000 angstroms for implantation energies of 100 keV. In ion plating, however, the coating is typically much thicker, and its composition is independent of the nature of the substrate. Although ion plating is often carried out with the substrates electrically biased at several keV the mean energy of the particles reaching the surface is probably of the order of only 100 eV or so. In addition, only a small fraction (<10%) of the particles are ionized when they reach the substrate. Ion plating is carried out under a relatively high pressure that causes atomic collisions and scattering. This factor is responsible for the high "throwing power" of the ion plating technique versus the "line-of-sight" limitation of implantation.

B. Historical Perspective

Since the early 1970's, ion implantation has been extensively used by the semiconductor device industry as a method of introducing controlled amounts of dopants into the surface region of semiconductor substrates. Its principal advantages for this application include improved controllability and reproducibility for device fabrication, as compared to thermal diffusion. The absolute concentration of implanted atoms and the uniformity across the sample surface may be controlled to better than 5% and 1%, respectively. The volume concentrations of impurities required in semiconductors typically range from parts per million to as high as 0.1 at.%, whereas the concentrations required for many of the non-semiconductor applications, such as for tools, are typically several atomic percent.

C. Ion Implantation - Advantages and Limitations of Technique

Some of the advantages and limitations of ion implantation in comparison to other surface treatments (such as coatings) are listed in the table below. A basic limitation of ion implantation is that it is a line-of-sight process and therefore cannot be applied to samples having complicated reentrant surfaces. The shallow depth of penetration is also a limitation in applications where the surface is rapidly lost or removed. However, there are numerous situations involving both physical and chemical properties where the engineering properties are controlled by a very thin surface layer.

Advantages and Limitations of Technique as a Surface Modification Technique

Advantages	Limitations
(1) Solid solubility limit can be exceeded	(1) Line-of-sight process
(2) Alloy preparation independent of diffusion constants	(2) Shallow penetration
(3) Allows fast screening of the effects of changes in alloy composition	(3) Relatively expensive equipment and processing costs
(4) No sacrifice of bulk properties	
(5) Low temperature process	
(6) No significant dimensional changes	
(7) No adhesion problems since there is no sharp interface	
(8) Depth concentration distribution controllable	
(9) Clean vacuum process	
(10) Highly controllable and reproducible	

As for the advantages, the fact that ion implantation is a nonequilibrium technique permits the formation of surface alloys whose formation is independent of solubility limits and diffusivities governing conventional alloy formation.

Ion implantation often allows the convenient production and subsequent study of surface alloys with well defined compositions. In this manner the technique can be used as a powerful research tool to examine the physical state of alloys as a function of varying alloy composition.

Ion implantation has other potential advantages for treating limited area critical parts. The surface properties can be optimized independently of the bulk properties and implantation can be carried out at low temperatures without producing any significant dimensional changes. In addition the surface alloy produced by implantation should not suffer from adhesion problems since there is no sharp interface.

D. Ion Implantation Equipment and Costs

This section is not intended to be a comprehensive description of ion-implantation equipment and its operation but only to give a brief introduction. There already exist in the literature detailed articles concerning the production and manipulation of ion beams for implantation and articles discussing the various advantages and disadvantages of particular ion implantation system designs.

A typical research-type ion implanter is shown in Fig. 2. It consists of an ion source capable of producing low-intensity ion beams of practically any stable element. Ions are extracted from the ion source by an electrode held at high potential and subsequently accelerated through an evacuated acceleration column during their passage from the source (held at the high voltage) to ground potential. Since ion sources normally produce ions of many species other than those that are desired for implantation, it is ordinarily essential to mass-analyze the beam in order to allow only the species of interest to continue toward the target. After mass analysis, the beam is electrostatically focused and steered towards a target chamber as well as being

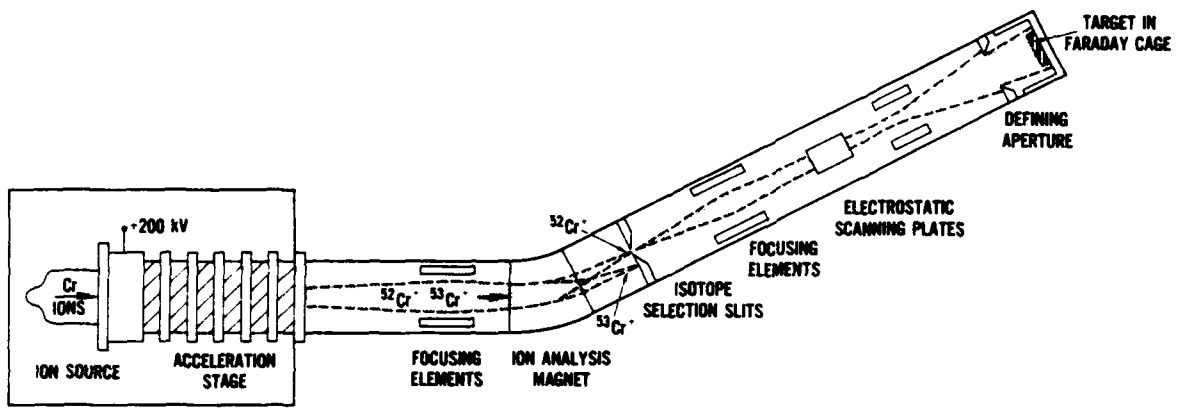

Fig. 2 — Schematic of a typical research-type ion implantation system

raster scanned over an aperture held in front of the target to ensure uniformity. The ion beam current passing through the defining aperture is then current integrated to obtain the impurity concentration (in dimensions of atoms per unit area) which in turn can be converted into a volume concentration by knowledge of the range-energy relationships for the projectile ion-host combination.

Before approximately 1970, the only machines available for implantation were either (i) modified research-type accelerators capable of producing microampere beams at energies up to several hundred keV or (ii) isotope separators capable of delivering milliampere beams at energies of tens of keV. These systems were quite satisfactory for semiconductor research applications but the desire to implement implantation for semiconductor device production provided a strong driving force for commercial companies to design production equipment to provide high-throughput and automated operation. The semiconductor applications have grown to the extent that there are now approximately 1400 production-type implanters throughout the world, with an estimated \$55 M worldwide sales in 1979. In addition to these production machines there are several hundred research-type machines in use throughout the world.

Figure 3 shows a schematic of a production-type ion implantation system used commercially for the processing of semiconductors. This type of implanter provides considerably higher beam currents than the system shown in Fig. 2. It is capable of processing approximately fifty three-inch wafers per hour with a doping uniformity less than 1% over the wafer and a day-to-day and wafer-to-wafer reproducibility of less than 0.5%. Present indications are that stringent dose and beam purity requirements can be significantly relaxed for many applications of implantation in metals (e.g., for improving wear or corrosion resistance). This should allow the machine designer more flexibility, possibly resulting in simpler machines. An important consideration for metals is the development of dedicated element ion sources and suitable target chambers that will allow the desired areas of the nonplanar targets (e.g., ball bearings) to be uniformly exposed to the ion beam. The estimated present cost for an implanter such as shown in Fig. 4 is \$400-500 K. High current machines built for non-semiconductor applications would probably cost about \$500-750 K.

For research application using limited areas, currently available machines will probably suffice. However any future engineering applications involving larger areas will necessarily require specialized systems involving either modification of existing design implantation systems, or development of entirely new design systems.

With currently available ion sources such as the one incorporated in the system shown in Fig. 4 it is possible to produce currents of up to approximately 1 mA for many of the ion species needed for non-semiconductor applications. This would correspond to a treatment time of approximately ten seconds per cm^2 to reach fluences that have been shown to improve corrosion or wear resistance (i.e., approximately 10^{17} atoms/ cm^2). If an operating cost of \$35/hr is assumed, these times correspond to costs of roughly \$0.15/ cm^2 . Further development of ion sources should significantly increase the attainable ion currents and hence lower costs. It should be noted that isotope separators (which are essentially low voltage ion implanters) were producing beam currents of tens to hundreds of milliamperes over 30 years ago. Given these currents and the significant improvements made in intervening years in ion beam technology the construction of high throughput implanters for metals processing should be quite feasible once the scientific merit and economic justification for each application is shown.

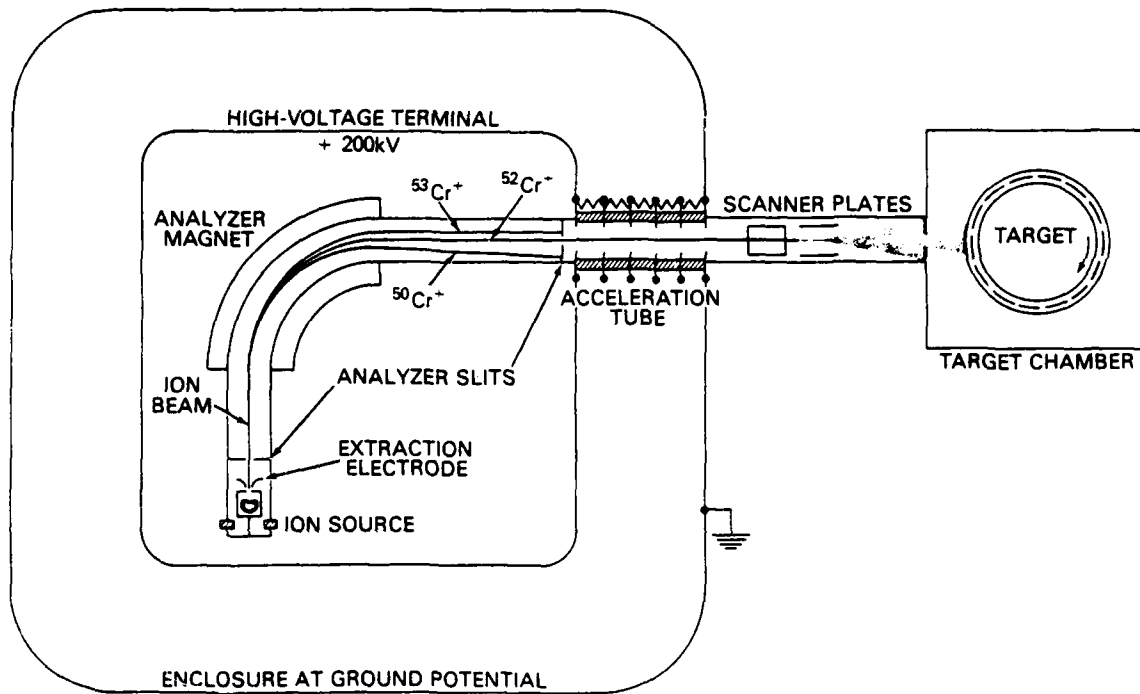

Fig. 3 — Schematic of a production-type ion implantation system for semiconductors

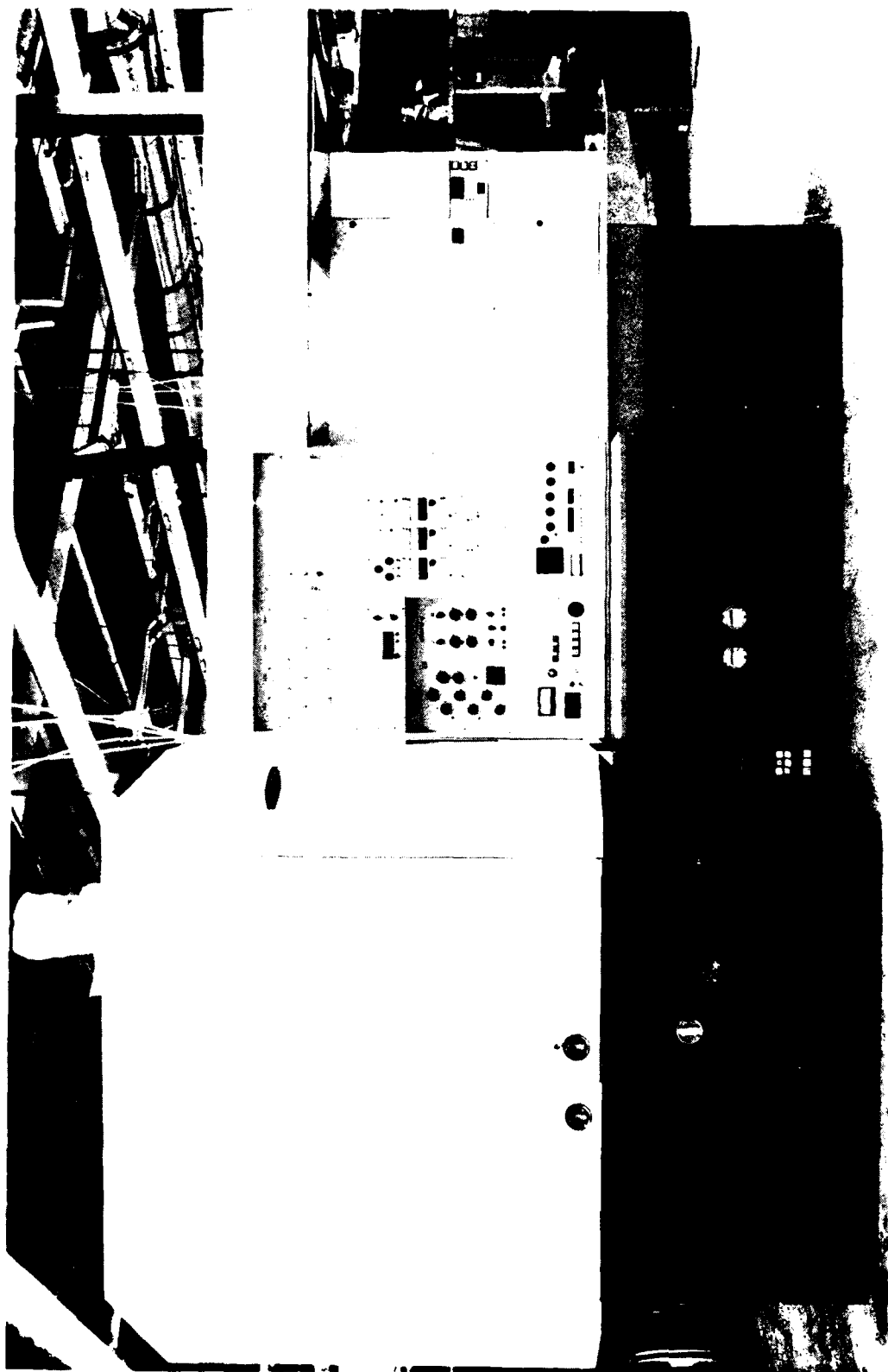

Fig. 4 — A 200-KeV high-current ion-implantation system used for semiconductor processing

10162-11

III. MAJOR FACTORS IN METAL REMOVAL OPERATIONS

A brief examination of some of the major factors in metal removal operations is necessary to place the approach selected for this study in proper perspective. An exhaustive review of the literature is not intended and the reader is referred to several excellent reviews [1,4-6] for a more comprehensive treatment of the subject.

A. Factors Affecting Tool Wear and Failure

Metal removal operations such as drilling, boring, milling, and turning in a lathe differ in the geometrical relationship between the tool and work piece but all can be reduced to the same basic process illustrated in Fig. 5. A tool moves relative to a work piece so that a thin layer of material is removed from the surface to reduce the work piece in size and leave a suitable finish on the resulting surface. Highly localized shear takes place along the line OD, the shear plane. The chip then slides along the rake face and may assume various configurations such as continuous, discontinuous, or built-up edge depending on such factors as cutting speed, ductility and work hardening characteristics of the work piece material and the angle of the rake face.

In machining there is a finite length of contact (length BE in Fig. 6) between the tool and the chip. Over a part of this length (BD) the contact between the chip and the tool is plastic. The remainder of the contact is elastic. The applicable slip line field (determined with plasticity theory) consists of a region of plastic contact (BCD), a centered fan region (ACD) and an isolated slip line (OAB), as shown schematically in Fig. 6.

By ion implantation, it is expected that the frictional characteristics of the tool material can be altered to change the applicable boundary conditions (of the plasticity problem) which prevail during machining along BDE, the tool-chip contact length. A reduction in local friction coefficient leads to lowered frictional heat dissipation along BDE and lower power requirements for machining through a lowering of chip shear strain during machining. The net result, apart from improving the energy efficiency during machining, is a lowering of the tool temperature which results in a lowered wear severity encountered by the tool during machining.

Apart from changing the sliding friction coefficient, ion implantation is also known to improve the wear resistance. Improvement in wear resistance is ion-specific. It is a purpose of the present program to identify the appropriate ionic species and to document the relative improvement in wear resistance. The heat generated by the shear processes and the heat generated by the frictional forces between the tool face and the chip cause an increase in temperature of the chip. Much of this heat is carried away in the chip but substantial increases in temperature do occur on the rake face. Cutting fluids are used to cool the tool and provide lubrication to reduce cutting forces although lubrication is not a factor in high speed continuous removal processes where the cutting edge remains buried in the work piece for long periods of time.

Tool failure can occur as a result of wear of the tool, fracture or overheating. Fracture results from subjecting the tool to cutting forces which are too high or using a tool which is too brittle for the work piece material. Overheating of the tool results from operating at a cutting speed too high for the tool material and may result in loss of strength of the tool material with resultant blunting of the tool edge and a catastrophic rise in temperature. The loss of strength may result from a metallurgical change such as overaging of martensitic tool steels or simply from a decrease in flow

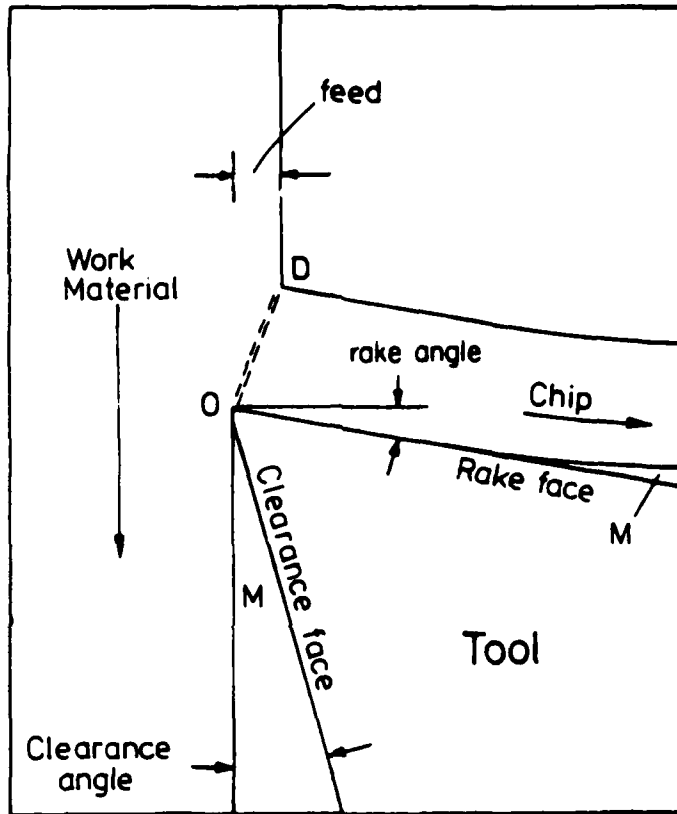

Fig. 5 – Schematic of the principle features of the tool and work material interaction during metal cutting operations

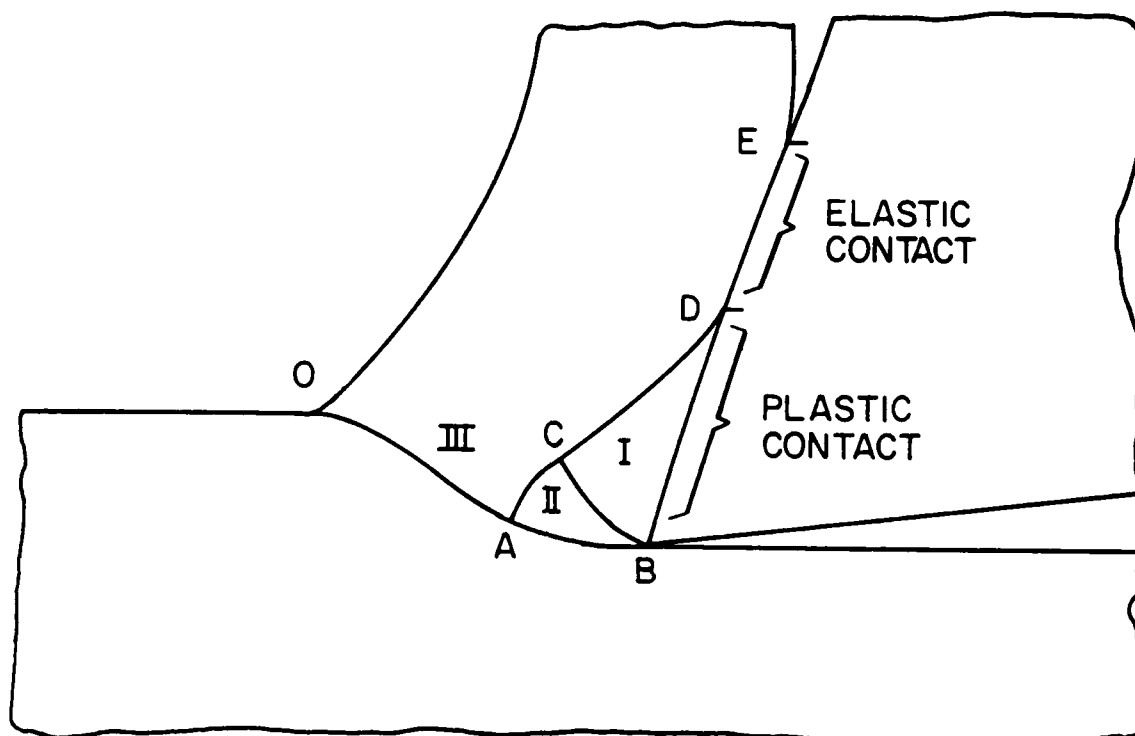

Fig. 6 — Slip line field applicable to chip formation during orthogonal machining

stress with temperature. The major cause of tool failure, for tools used under the normal range of operating conditions, are crater wear on the rake face and the development of wear lands on the clearance face. The location of these wear regions are illustrated in Fig. 7. Wear in these locations leads to a degradation in surface finish and loss of tolerance on the part. Crater wear is related to the temperature of the rake face and the location of the crater correlates directly with the distribution of temperature on the rake face. Trent [4] has shown some graphic examples of this relationship. Cratering may also be accelerated if a chemical reaction occurs as in the case of the machining of low carbon steels with cemented tungsten carbide tools where the WC decomposes during the machining and the iron reacts with the carbon.

The wear of cutting tools is a complex phenomena and it seems unlikely that a single mechanism is responsible for all forms of wear observed in practice. Abrasive wear, surface fatigue or delamination, and oxidative or corrosive wear are recognized by most workers in the field as being the principal contributors to tool wear

Abrasive wear is visualized as a process in which a small hard particle ploughs a track in a softer material serving as a miniature cutting tool to remove material from the softer surface. Empirical correlations between hardness and abrasive resistance such as those illustrated in Fig. 8 are well known. Oxide inclusions have been shown to be the primary source of abrasive wear particles in the machining of steels [7]. Alumina and silica in particular have high hardness. The situation is exacerbated because the tool hardness decreases faster as it heats up during the machining operation while the oxide inclusions impact the tool face at near ambient temperature. Table 1 shows the change in hardness for various phases present in steel [5]. Suh quotes a figure of 4.5 as the necessary hardness ratio between tool and work piece to eliminate abrasive wear [5]. No such materials currently exist. Abrasive wear can also be ameliorated by inclusions in the steel such as MnS or Lead which provide a low friction surface film at the tool face-chip interface [7].

The delamination theory of wear developed by Suh postulates that repeated contact with a sliding surface results in cyclical plastic deformation of the surface layers. As the plastic strain increases, cracks nucleate around inclusions or in dislocation cell walls. The cracks first propagate and link up below the surface and subsequently shear to the surface so that the surface flakes or delaminates in sheets. Suh predicts that delamination wear will occur for tool wear under hard abrasive particles when hard abrasive particles have a ratio of width of penetration to tip radius less than 0.2 [5].

Chemical instability as a factor in wear was mentioned in the previous discussion of crater wear and its correlation with temperature profiles on the rake surface. Older literature sometimes mentions a diffusional wear process in which solutes were hypothesized to diffuse across the chip-tool interface to degrade the properties of the tool material and accelerate wear rate. A more thorough analysis of the chip motion relative to the tool makes a diffusional process appear less likely. Dissociation of the cutting tool material with subsequent dissolution of the constituents provides a more viable alternative. Suh and co-workers have shown good correlation between high heats of formation of refractory compounds and wear resistance [5]. Reaction of the tool material with the atmosphere or the cutting fluid can also contribute to oxidative or corrosive wear.

B. Materials Selection and Processing for Wear Reduction

The major classes of materials with high usage for cutting tools include the high

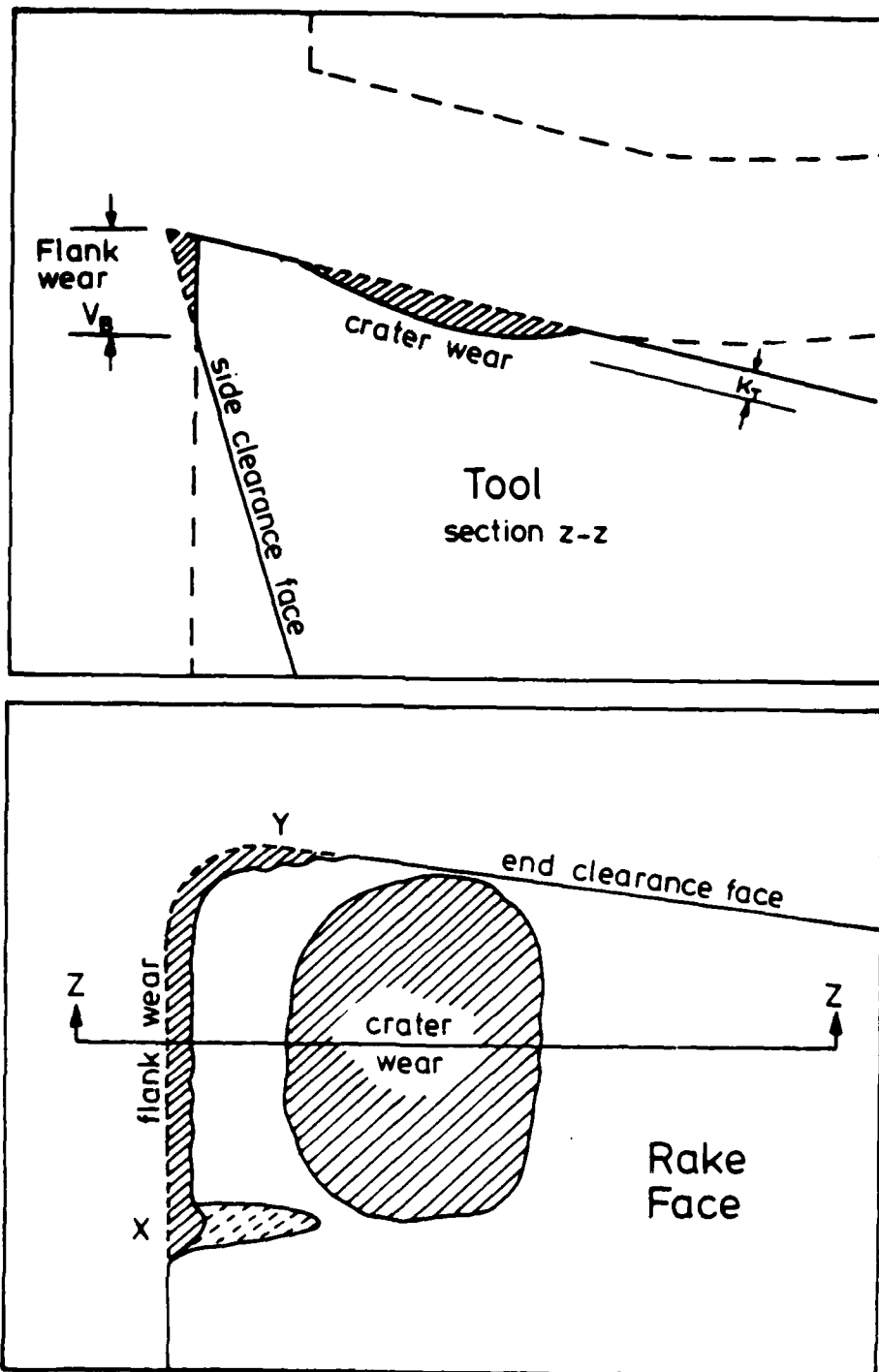

Fig. 7 — Schematic illustration of the characteristic wear features that develop on a lathe tool bit during machining operations

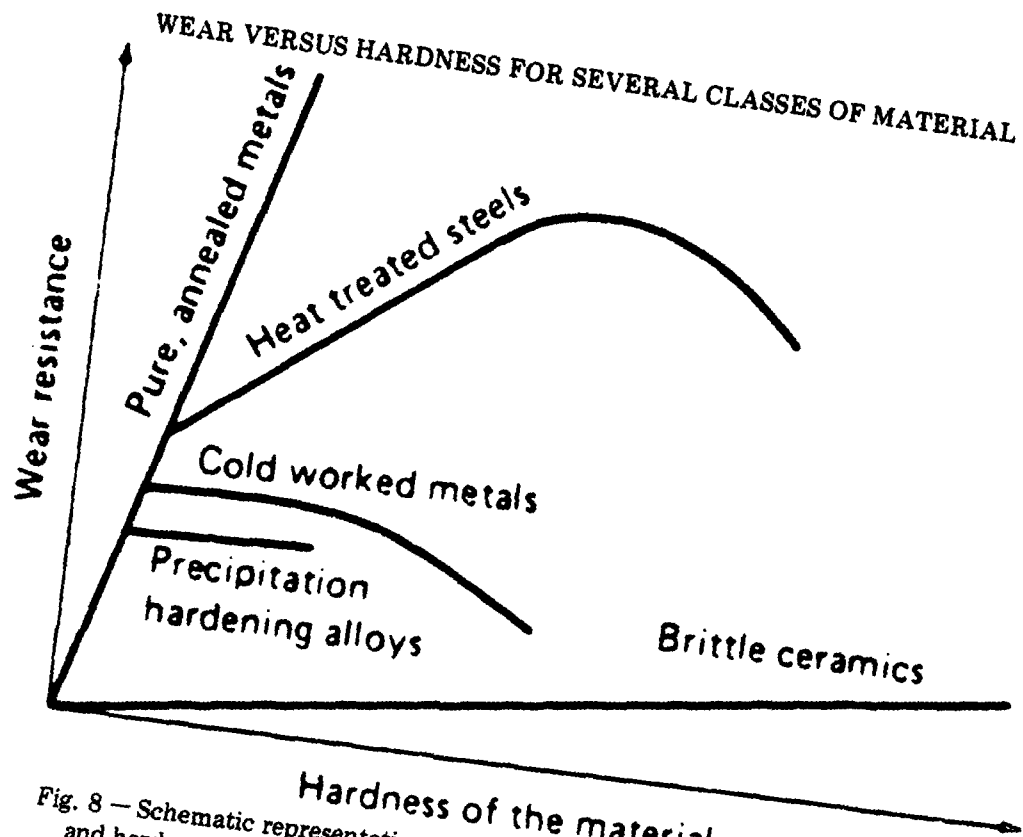

Fig. 8 — Schematic representation of the correlation between wear resistance and hardness of different materials in various microstructural conditions

TABLE 1

Hardness at Specified Temperatures of the Phases
that May Be Present in a Steel

Phase	Hardness H_v (kgf mm^{-2})		
	400°C	600°C	800°C
Iron	45	27	10
Iron and Interstitials	90	27	10
TiO	1300	1000	650
FeO	350	210	50
MgO	320	220	130
NiO	200	140	100
MnO	120	60	45
Al ₂ O ₃	1300	1000	650
SiO ₂	700	500	300
ZrO ₂	650	400	350
TiO ₂	380	250	160
MgAlO ₄	1250	1200	1050
ZrSiO ₄	400	290	140

speed steels, cemented tungsten carbides in cobalt binders, cemented tungsten carbides plus titanium and tantalum carbides in cobalt binder, aluminum oxide ceramics, diamond and titanium carbide coated cemented carbide tools. More detailed information on each material and its performance characteristics can be found in the Metals Handbook [6] and a more general review of wear resisting materials and surface treatment is given by Eyre [9]. Suh [5] discusses conventional materials as well as new concepts in tool materials.

The selection of tool material for a particular machining application depends on a number of factors such as hardness of the work piece, cutting speed and the accompanying rise in temperature, reactivity with work piece material, fabricability of tool material and intricacy of the cutting tool geometry, cost, available power for the machine, rigidity of the machine, and surface finish required. In general, one would like to select a material to operate at the highest cutting speed possible with the power and rigidity of the machine available. The upper limit is established by excessive failure rates for the tool by fracture, overheating, excessive wear, or an unacceptable surface finish. In general, the wear resistance and thermal stability increase in the series of high speed steel - cemented tungsten carbide - cemented tungsten carbide with additions of titanium and tantalum carbide - ceramics. The shock resistance decreases as the wear resistance increases so compromises must be made to select an acceptable failure rate. This choice is usually on the basis of economic considerations.

Surface treatment is an attractive approach to achieve the compromise between adequate shock resistance in the bulk material and a favorable hardness or friction coefficient on the surface. Surface hardening treatments such as carburizing and nitriding of steel have been in commercial practice for a long time. Their principal disadvantage is that many of these treatments require temperatures in the range where tempering and annealing of the steel take place. Chemical vapor deposition (CVD) of the titanium carbide to provide a thin (.0002-.0003 in.) coating over cemented tungsten carbide tools produces a substantial increase in performance of the tool. Figure 9 shows a comparison of machining speeds attainable with coated tools and other common tool materials. This increase in performance is attributed to the decrease in friction with TiC and attendant lowering of temperature as well as the excellent high temperature stability and high hardness. In the CVD process the substrate is heated and exposed to a mixture of gases which react at the substrate surface to form a solid deposit. The technique is a batch process in which many small parts are exposed at one time. A limitation of the process is the high temperature required (near 1000°C) so that only refractory tool materials can be used for the substrate. Another disadvantage is that such tools cannot be sharpened without recoating of the tool. Adherence of the coating is also a problem. Ion plating and ion implantation offer some attractive features as surface treatment techniques because of the flexibility in elemental species which can be added to the surface, the absence of adherence problems, and the ability to modify the surface without exposing the bulk material to excessive temperatures.

C. Cost Factors in Machining Operations

The ultimate driving factor in machining operations is the economy of the operation. A qualitative analysis of the principal cost factors is provided in Fig. 10. The major parameters are the cost per unit produced and the cutting speed. Material costs and facility costs are fixed. Machining cost per part decreases with cutting speed; tool cost including reconditioning eventually increases rapidly at high cutting speeds. Tool changing costs also increase with the high failure rate. A linear

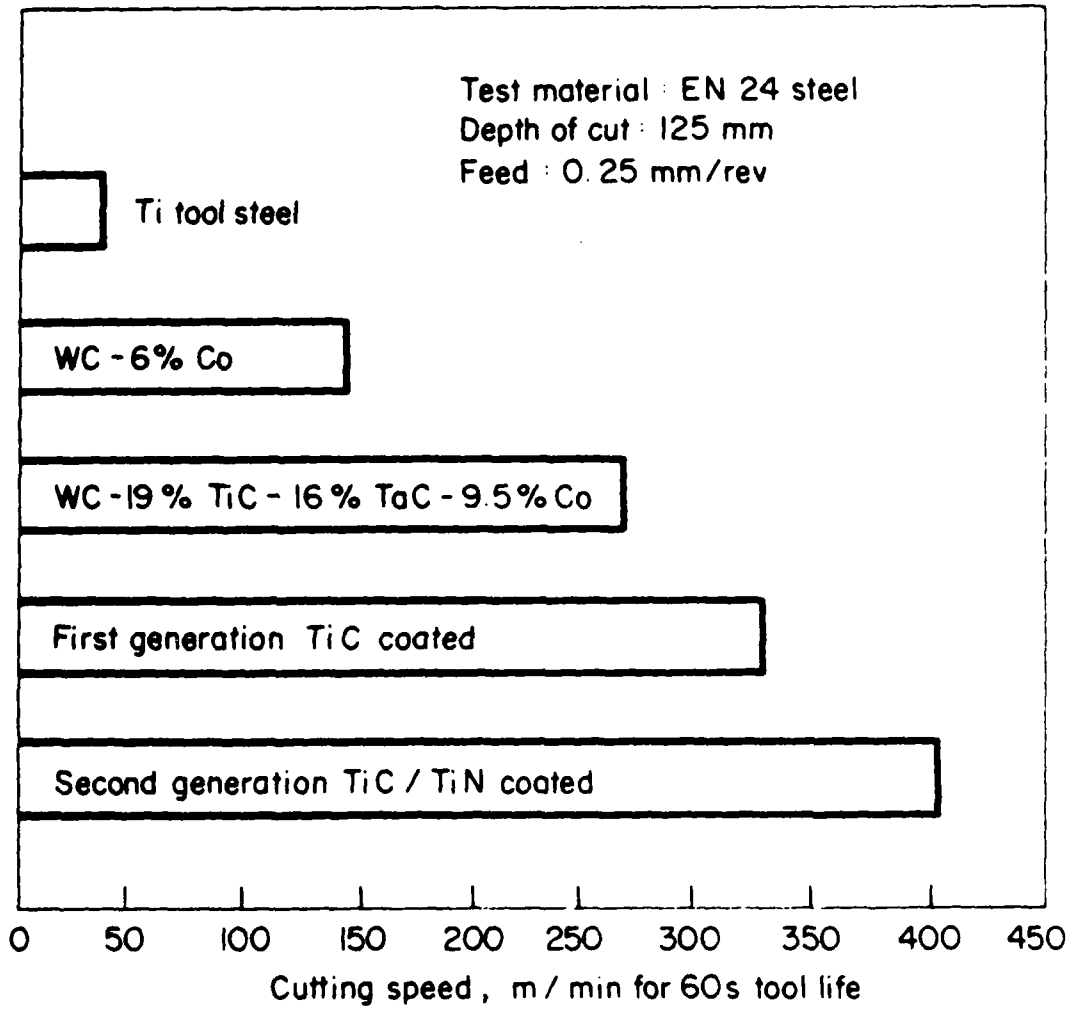

Fig. 9 — Improvements in the cutting speed which have been achieved by advances in cutting tool materials

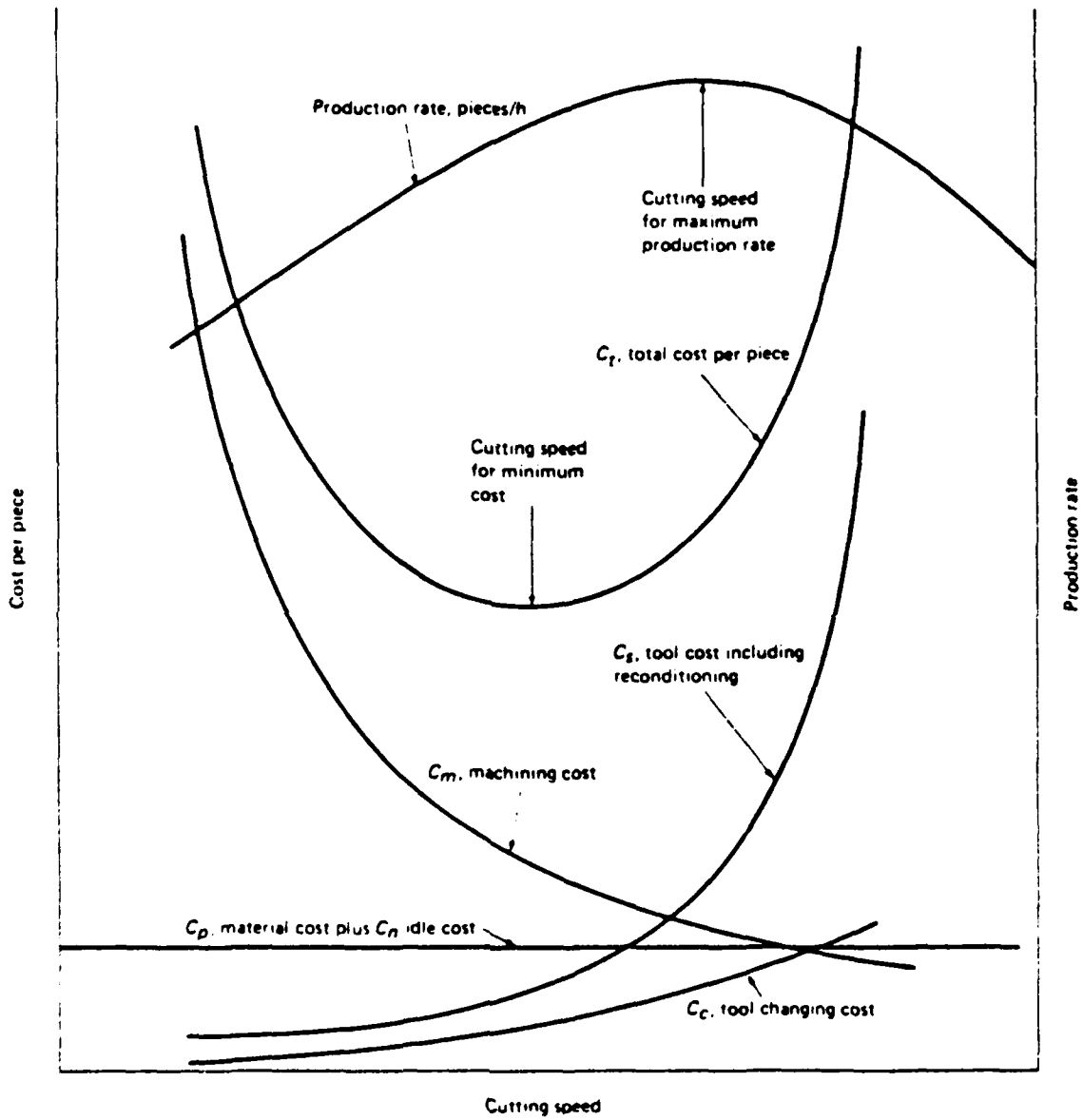

Fig. 10 — Schematic representation of the major cost factors in machining operations and the dependence of cost and production rate on cutting speed

superposition of the above factors leads to total cost per part curves with a minimum that represents the most economical cutting speed. The production rate curve shows a maximum which is somewhat above the most economical cutting speed. Shaw [1] gives the analytical form of the above equation for optimum cost per part and provides some sample calculations. More sophisticated analytical methods using operations research have also been applied to the problem [10] but yield qualitatively similar results. The most important point to recognize is the impact of cutting speed on the economics of the process.

Another important perspective on the economics of machining is provided in Fig. 11 which shows the contribution of various costs to the total cost of slotting cutters and face mills for three types of material and three sizes. Costs considered are tool material, cost to make the tool, cost to grind the tool and other costs such as heat treating. It is important to note that the actual cost of the tool material is a small fraction of the total cost. Surface treatments such as ion implantation that extend the life of tools with intricate shapes and therefore high manufacturing costs are easily justified on a cost basis.

IV. SELECTION OF MATERIAL SYSTEM FOR EXPERIMENTAL EVALUATION OF WEAR REDUCTION IN MACHINE TOOLS

The previous section described briefly the major classes of materials used in metal cutting tools. The most widely used material for severe metal cutting conditions are the cemented tungsten carbides while the high speed steels are the highest tonnage material because of superior fabricability and lower cost. High speed steels are still used in metal cutting applications where power and rigidity limitations of older equipment do not permit the effective use of carbide inserts and where the complexity of the tool design dictates the use of more easily fabricated materials. Preliminary discussions with the sponsor established a strong interest in the high speed steel class of tool materials so the experimental evaluations were centered on those materials. Metal cutting operations where high speed steel would find extensive use include forming, parting, grooving, planing, shaping, broaching, milling, hobbing, drilling, reaming, tapping and sawing.

The high speed steels are high carbon, hardenable, alloy steels produced to close quality control for reproduceable properties. Carbon contents typically range from 0.75 to 1.25 wt%. Alloy contents are 3 to 4% Cr plus W, Mo, V and sometimes Co. Typical compositions for the high tonnage alloys M2, M50, M7, T1, and T15 are given in Table 2 along with AISI 52100, an alloy which will be mentioned in the following discussion. Steels of this composition can be deep hardened to Rockwell C-65 when quenched from the austenitizing temperature of 1230°C. An oil quench is used for sections over 3 in. in diameter while a hot salt quench and air cool is used for thinner sections. This heat treatment produces a hard martensitic structure with alloy carbides. In the "as-quenched" condition these steels contain 0.5 percent carbon in the matrix with the balance in alloy carbides of the M_6C and MC type $Fe_4(Mo,W)_2C$ and VC . Figure 12 shows the softening characteristics of several classes of tool material including T1 and M2 high speed steels. And it can be seen that substantial softening occurs above 1050°F (565°C). Improvements in wear resistance of high speed steel tools should then be sought in surface treatments yielding a higher surface hardness than Rockwell C-65 (or Knoop microhardness of 846) and better retention of hardness at temperatures above 565°C.

Research on wear improvement of AISI 52100 bearing steel conducted at NRL [12,13] offered some promising directions for the initial experiments on high speed

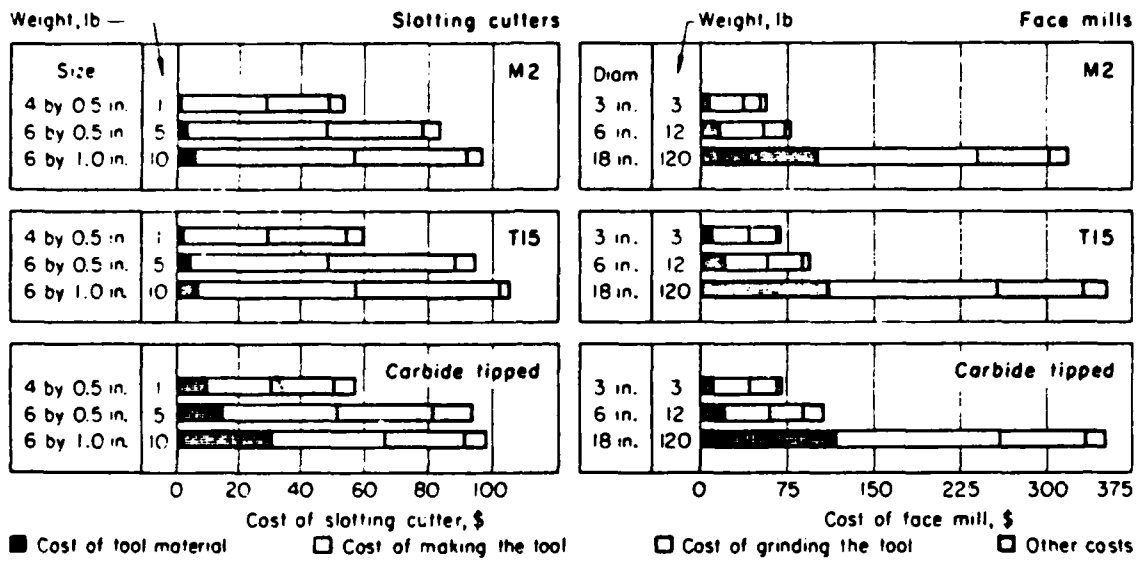

Fig. 11 — Effect of tool size and weight on material cost, processing cost and total cost of slotting cutters and face mills

TABLE 2

Nominal Composition of High Speed Steels (Wt-%)

Steel	C	Cr	V	W	Mo	Co
<u>Molybdenum High Speed Steels</u>						
M2, Class 1	0.85	4.00	2.00	6.25	5.00	
M7	1.02	3.75	2.00	1.75	8.75	
M50	0.80	4.00	1.00	-	4.25	
<u>Tungsten High Speed Steels</u>						
T1	0.73	4.00	1.00	18.00		
T15	1.55	4.50	5.00	12.50	0.60	5.00
<u>Bearing Steel</u>						
52100	1.05	1.45				

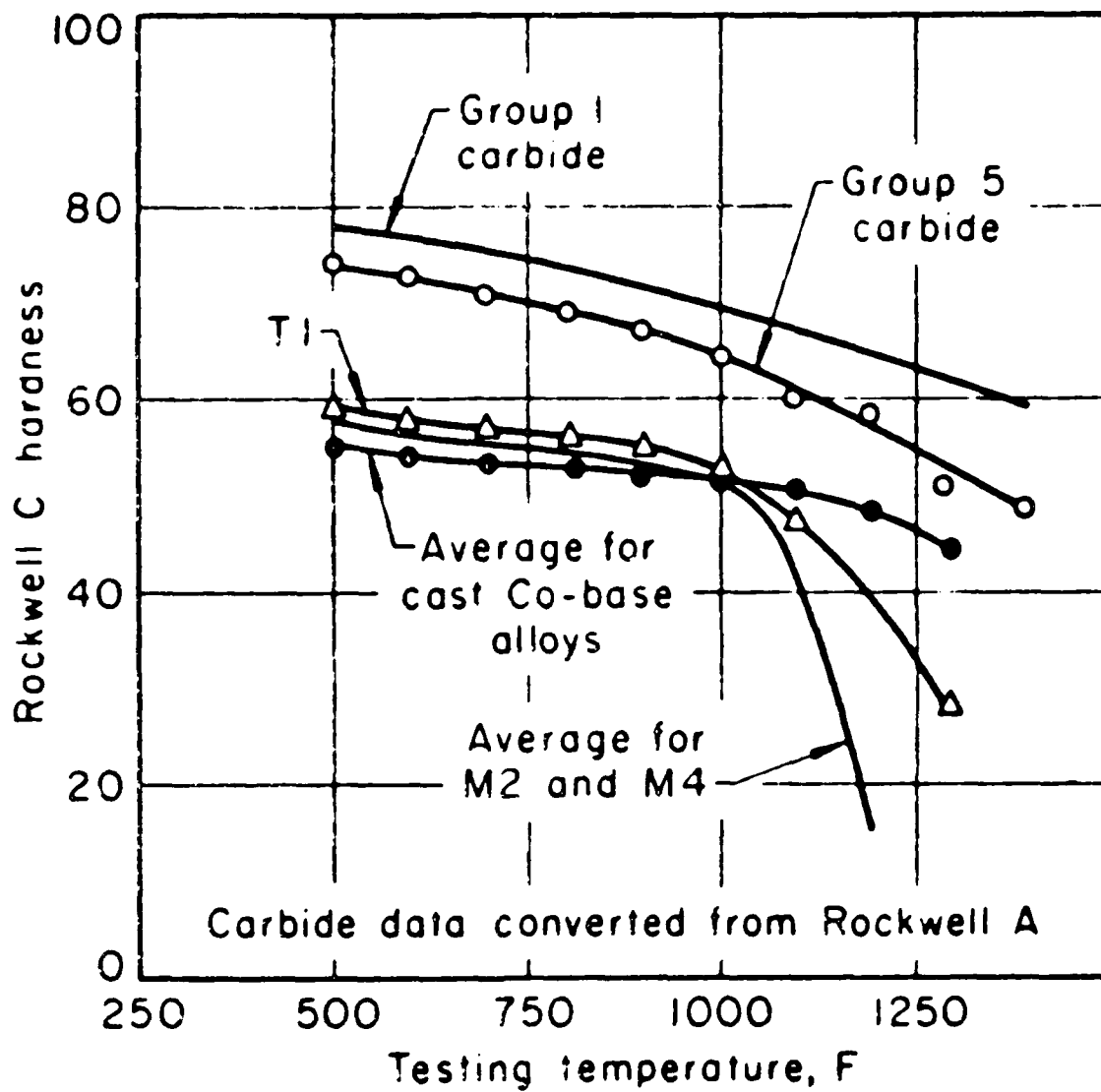

Fig. 12 — Effect of testing temperature on the hardness of high speed steels, cast cobalt-base alloys and sintered carbides

steels. AISI 52100 is also a high carbon steel used in high wear applications such as bearings but the alloy content is less than the high speed steels with no Mo, W, or V as shown in Table 2. The experiments on AISI 52100 consisted of surface modification of the steel by implantation of titanium, several types of wear experiments to compare the wear properties with unimplanted material, and surface analysis to determine the structure and composition of the implanted surface. Figure 13 shows the experimental arrangement for the determination of coefficient of friction. A 52100 ball with a one kg load imposed bears on a platen implanted with titanium. The platen is then moved with respect to the ball. The coefficient of friction was found to vary with the number of passes and with the implantation dose. Wear scars viewed with an interference microscope are shown in Fig. 14 for the corresponding conditions in the friction experiment. A full explanation of these results requires additional information on the analysis of the surface layers. It should be noted however that the 50×10^{16} Ti/cm² fluence results in a persistent reduction of the coefficient of friction from 0.61 to 0.35 and that the surface is so hard that it is not scarred by the wear test with 1 kg load (Hertzian pressure of 400 MPa [58 ksi]).

Two types of wear tests were also conducted and show the benefits of ion implantation. Figure 15 shows a pin-on disk test where wear volume is measured by the change in diameter of a tapered pin and the profile of the wear scar. Hexadecane Z, a poor boundary lubricant, was used to adjust the wear life for periods that could be reasonably measured. A load of 1 kg was used in the test. The major effect of the titanium implant was to delay the onset of severe wear. This initiation point was somewhat variable but in all cases extended the threshold for onset of severe wear by a factor of ten. Lubricated wear tests were also conducted for a 52100 ball sliding against a 52100 race implanted with 2×10^{17} Ti/cm² under a load of 2 kg (Hertzian pressure of 810 MPa, [117 ksi]). The lubricant was a synthetic polyester lubricant used for turbojet engine bearings. As can be seen in Fig. 16 the wear rate after running-in is a factor of 7 lower for the Ti implanted bearing race under lubricated wear conditions.

The friction and wear results for AISI 52100 can be rationalized when information on the surface chemistry is available. Figure 17 shows composition profiles for oxygen, carbon, titanium and iron obtained from Auger electron spectroscopy peak height measurements on the implanted region in a 5×10^{17} Ti/cm² specimen which has been ion milled to give a depth profile. The vertical line at 7 minutes indicates a change in milling speed. Information on the chemical state of the elements can also be determined from the Auger electron line shapes and characteristic lineshapes are noted on the figure. The composition changes from the outer surface into the metal interior show a hydrocarbon overlayer, a thin iron oxide layer, a titanium oxide layer, titanium carbide, and finally, metallic titanium, iron and carbon in solid solution. Auger analyses of lower fluence specimens show proportionally more titanium and less carbon than in the high fluence specimen. The higher proportion of titanium produces a high coefficient of friction because it prevents the formation of the normal air-formed iron oxide which provides some lubrication of the sliding surface. In the high fluence specimen the titanium carbide provides a hard surface with excellent tribological properties. This information on composition of the surface layer provides a suitable explanation of the change in frictional properties with Ti implant fluence shown in Fig. 13. The most desirable properties are those of the hard TiC layer.

Transmission electron microscopy observation of the surface [13] shows the surface layer to be amorphous. It is hypothesized that carbon from hydrocarbon vapors in the vacuum chamber reacts with the exposed titanium in the surface of the specimen under ion bombardment and reacts to form the Ti-C-Fe amorphous layer. Research is still in progress to determine the relative importance of the TiC bonding

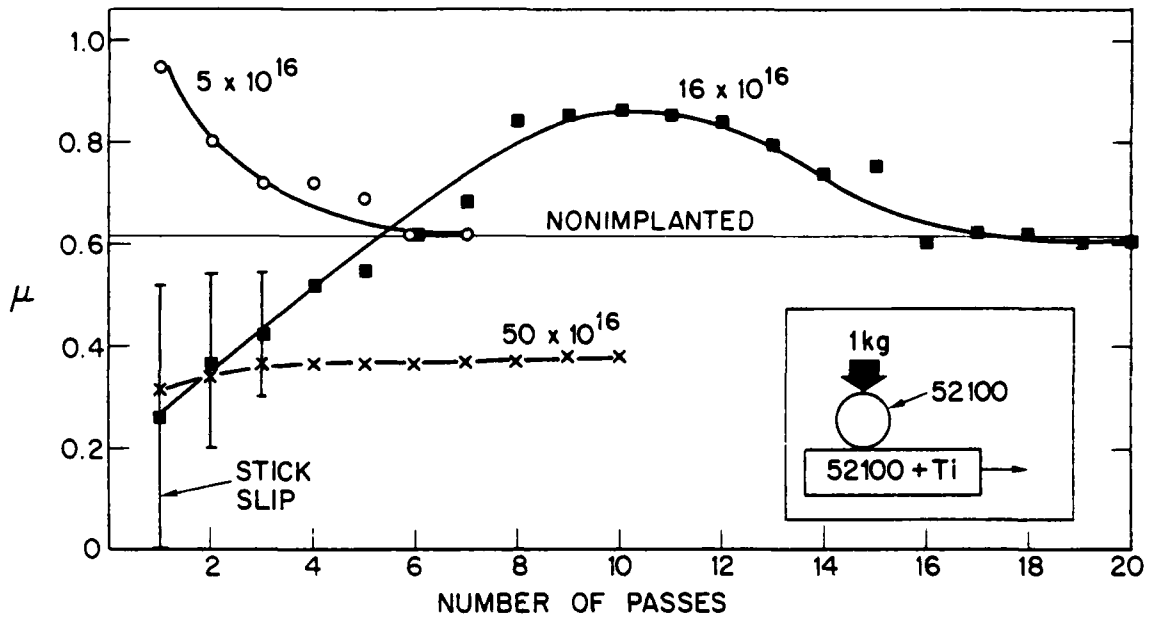
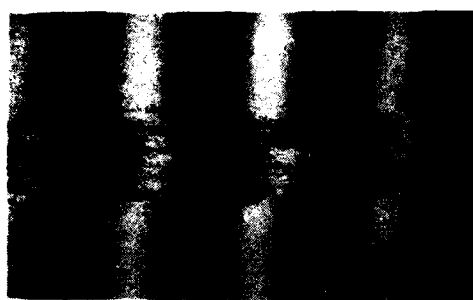
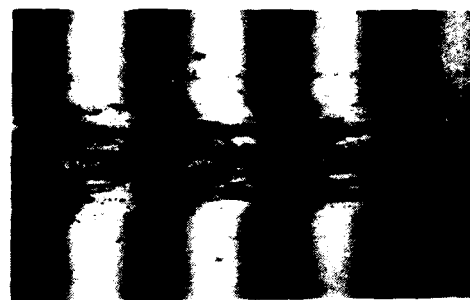

Fig. 13 — Experimental arrangement (lower right hand corner), and data for the coefficient of friction between an AISI-52100 steel ball and a 52100 flat surface implanted with Ti. Three distinct types of behavior are observed which are dependent on the fluence of Ti ions implanted onto the surface.

INTERFERENCE MICROGRAPH OF WEAR SCARS ON Ti-IMPLANTED 52100 STEEL



$16 \times 10^{16} \text{ Ti/cm}^2$
10 PASSES



$16 \times 10^{16} \text{ Ti/cm}^2$
20 PASSES



$50 \times 10^{16} \text{ Ti/cm}^2$
10 PASSES



$5 \times 10^{16} \text{ Ti/cm}^2$
7 PASSES

R-144

Fig. 14 — Wear scars produced on AISI-52100 steel polished flats implanted with various fluences of Ti ions as viewed by interferometry. Experimental conditions are as follows: (a) 50×10^{16} ions/cm² after 10 passes of loaded ball (b) 16×10^{16} ions/cm² after 10 passes (c) 16×10^{16} ions/cm² after 20 passes (d) 5×10^{16} ions/cm² after 7 passes (similar in appearance to unimplanted surface).

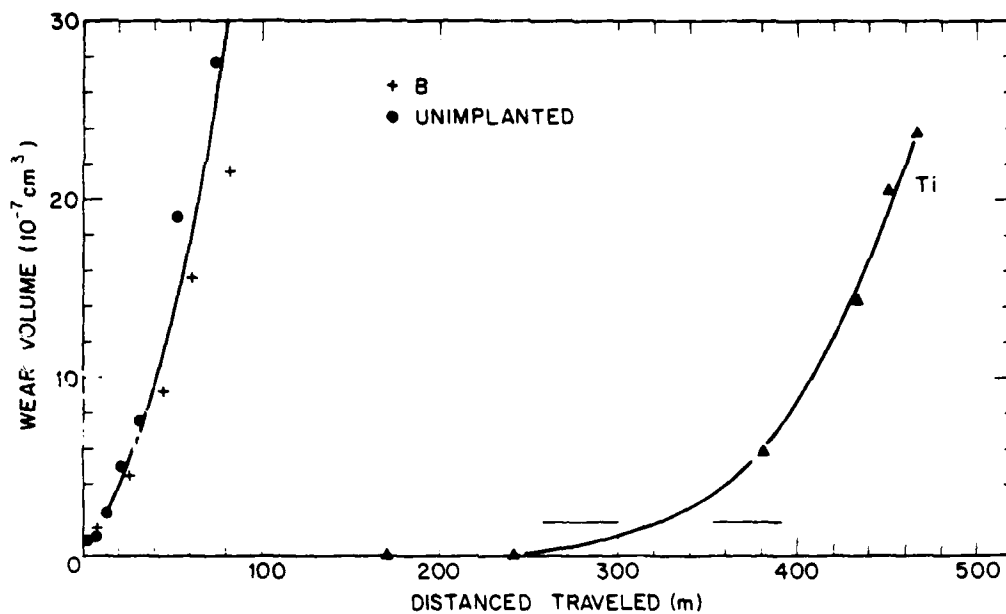

Fig. 15 — Wear volume for AISE-52100 ball on 52100 disk surfaces unimplanted, implanted with B, and implanted with 5×10^{17} Ti ions/cm². The arrows beside the Ti curve indicate that the onset of severe wear is variable but begins at substantially larger distances than in the unimplanted specimen.

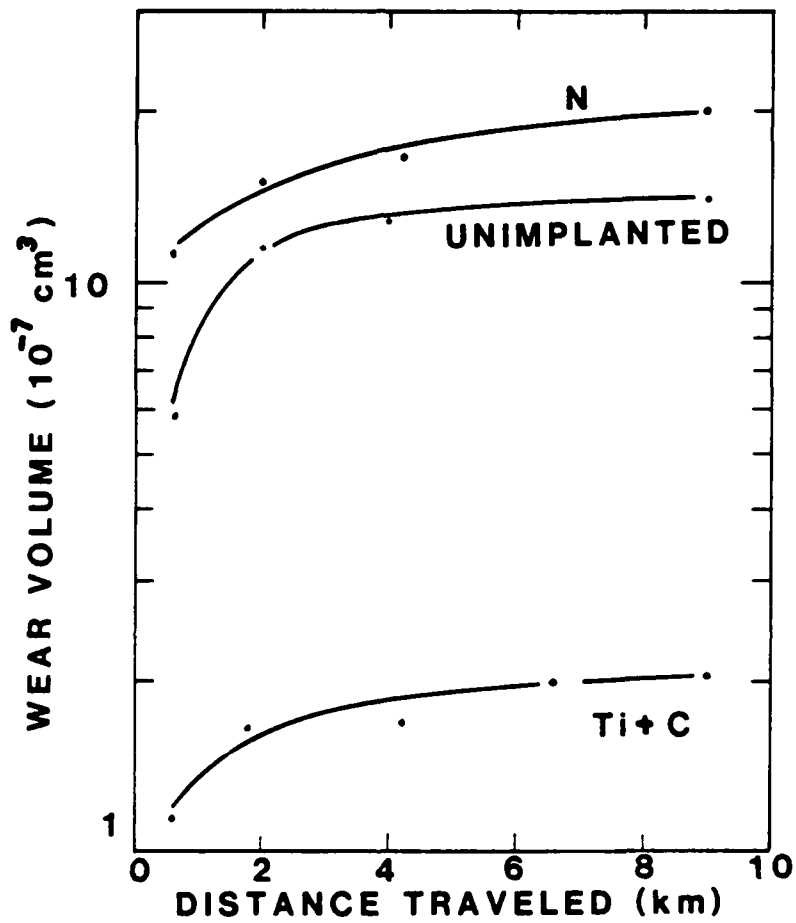

Fig. 16 — Wear experiments using a ball on cylinder configuration to investigate the “running-in” portion of the wear regime. Ti implants of 2×10^{17} ions/cm² show substantially better performance than unimplanted and nitrogen implanted specimens.

and the amorphous layer in imparting the remarkable improvements in wear observed in this material. A similar approach is proposed to improve the wear resistance of high speed steels in wear applications.

While high speed steel is the largest tonnage material for machine tool bits, it does not have the wear resistance of either cemented tungsten carbides or the titanium carbide coated tools. A minor effort was undertaken to evaluate the possibility of improving the wear resistance of these latter materials by ion implantation. A carbide tool insert of Carbolloy Grade 895, 94WC-6Co, was implanted with carbon ions to surface harden the cobalt binder. A titanium carbide coated Carbolloy 895 tool insert was also implanted with carbon, nitrogen and boron ions to evaluate the benefits of surface modification of the TiC. The addition of nitrogen to TiC to form Ti(CN) is known to strengthen the material while the implantation of boron was done to strengthen the material with TiB_2 [14].

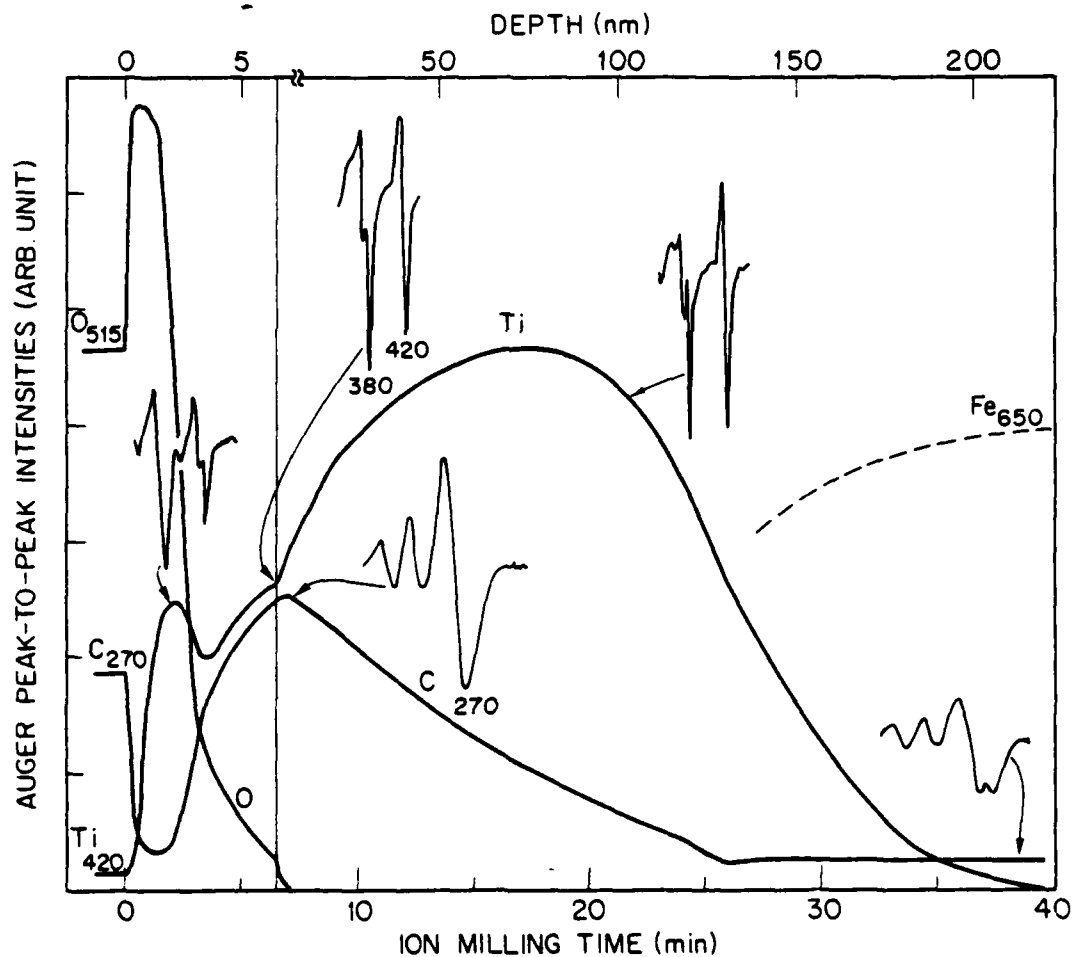

Fig. 17 — Concentration profiles for carbon, oxygen, titanium and iron for an AISI-52100 specimen implanted with 5×10^{17} Ti ions/cm². The profiles were determined from Auger electron spectroscopy measurements taken periodically during ion milling of the implanted surface. The vertical line at 7 minutes indicates a change in milling rate. Characteristic Auger peak shapes at various locations in the specimen are shown to illustrate changes in atomic bonding as a function of depth in the specimen.

V. EXPERIMENTAL RESULTS

The experimental program conducted as part of this evaluation was designed to provide a quick screening of the materials system concepts described in Section IV so as to provide guidance for the most promising system for application of ion implantation. Experimental tests for wear behavior are numerous because of the difficulty in correlating the different types of wear and the complexity of the conditions controlling wear. The wear of cutting tools is one of the most severe forms of wear with unlubricated metal-to-metal contact under stresses approaching the yield stress. Several tests were selected to evaluate the ion implanted cutting tools: a pin-on disk test commonly used to evaluate sliding wear, an instrumented lathe test used to measure cutting forces and flank wear under carefully controlled conditions, and some actual machining tests with several diameters of end mills and drills. The results of each of these tests in which ion implanted specimens are compared with unimplanted specimens is given in the following sections. The conditions of ion implantation are also described.

A. Ion Implantation

The implantations were performed on a Varian/Extrion medium current semiconductor implanter adapted by NRL for metals implantations. Titanium was chosen to be implanted into the M2 tool steel on the basis of previous NRL wear studies which showed that Ti-implanted AISI 52100 bearing alloy has an abrasive wear resistance approaching that of refractory carbides. A minor effort was also devoted to implanting N and B into the surface of TiC coated Carbolloy 895 tools.

The samples were implanted on all faces experiencing wear. The M2 samples were thermally attached to the water cooled target holder so as to limit their temperature rise to less than 150°C during implantation. One group of TiC on WC inserts was implanted at low temperature and another group was intentionally thermally isolated so as to induce the diffusion and subsequent interaction of the implanted species with the TiC matrix. These samples reached a maximum temperature of 600°C for a period of about 1 hour during implantation.

The Ti implantation into the M2 cutting tool inserts was done at an energy (150 keV) and dose (5×10^{17} Ti ions/cm²) to produce an implanted region about 80 nm in depth. The N, B, and C implants into TiC were all done at two energies (75 and 150 keV) at a dose of 2.5×10^{17} ions/cm² at each energy. The dual energy implants were done in order to spread the implanted species (i.e., initially from about .1 μm to .2 μm).

Selected machine tools have been implanted and tested at FMC Corporation. The tools implanted and the quantity are as follows:

<u>Tool</u>	<u>Size</u>	<u>No.</u>	<u>NRL Code</u>
End Mills, 2 flute	1" diam	2 ea	1A, 1B
End Mill, 4 flute	7/16" diam	2 ea	2A, 2B
End Mill, 2 flute	3/16" diam	1 ea	3A
End Mill, 2 flute	1/4" diam	1 ea	3B
Drills	1 1/8" diam x 8" length	2 ea	4A, 4B

All tools were previously identified as M7 high speed steel by FMC.

The tools have all received an implant of 4×10^{17} Titanium ions/cm² with an implantation energy of 100 kV. The objective of this treatment is to form a thin layer of hard TiC at the surface. All tools except the 7/16", 4 flute end mill were implanted from the side while rotating the tool. The 7/16" end mill used for facing cuts was also implanted on the end to assure coverage of the cutting surfaces. The bright surface shows the area of implant. This mode of implantation would permit regrinding of the tool without removing the implanted layer on the inner surface of the flute and cutting edge.

In addition, eight M7 experimental wear discs have been implanted at the same energy and fluences as above for the purpose of conducting laboratory pin-on disc wear measurements.

B. Instrumented Lathe Tests

The instrumented lathe tests were the primary vehicle for evaluation of the effect of ion implantation on the machining parameters and tool life. The tests were conducted by Professor S. Ramalingam of Georgia Institute of Technology in his laboratory. This test provides a quantitative evaluation of the cutting forces on a lathe tool as a function of cutting speed and a measurement of wear rate from the flank wear of a tool under carefully controlled conditions.

Test Conditions. Two series of tests are in progress to evaluate the possible benefits of ion implanting cutting tools for machining applications. The first series of tests are cutting force measurement studies to assess the effect of ion implantation on the tool-chip interface friction and on the specific power consumption during machining. The second series of studies are concerned with the effect of ion implantation on tool wear.

Fully hardened unimplanted and ion implanted M2 high speed steel inserts were used in these studies. Unimplanted cutting tool edges were compared with those implanted with titanium ions (150 keV ions; 5×10^{17} ions/cm² fluence).

An annealed carbon steel (4140) was machined in a 7.5 kW (10 hp) lathe equipped with a continuously variable speed drive. The lathe is instrumented with a Kistler 3-component dynamometer, charge amplifiers, recorders and digital speed indicators. The Kistler 3-component dynamometer measures the principal cutting forces exerted on a lathe tool bit as illustrated in Fig. 18. F_c - the cutting force is the major force component on the tool and is parallel to the direction of movement of the metal being removed prior to shearing by the cutting edge. The force, F_f , is the feed force normal to the surface of the work piece while the force F_R is the radial force which is zero in orthogonal cutting. Figure 19 shows a schematic diagram of the piezoelectric cutting force instrument in the form of a tool holder and the signal processing and readout system used for the measurements. Full details of the measurement system are provided in ref [15].

For all tests, the cutting tool inserts were held in a standard square insert tool holder with a 6° rake position during machining. To simulate semi-orthogonal cutting, an approach angle of 5° was used in the force measurement tests. In tool wear tests (flank wear studies), the normal 15° approach angle was used. Figure 20 illustrates the tool geometry used during machining for the cases described above.

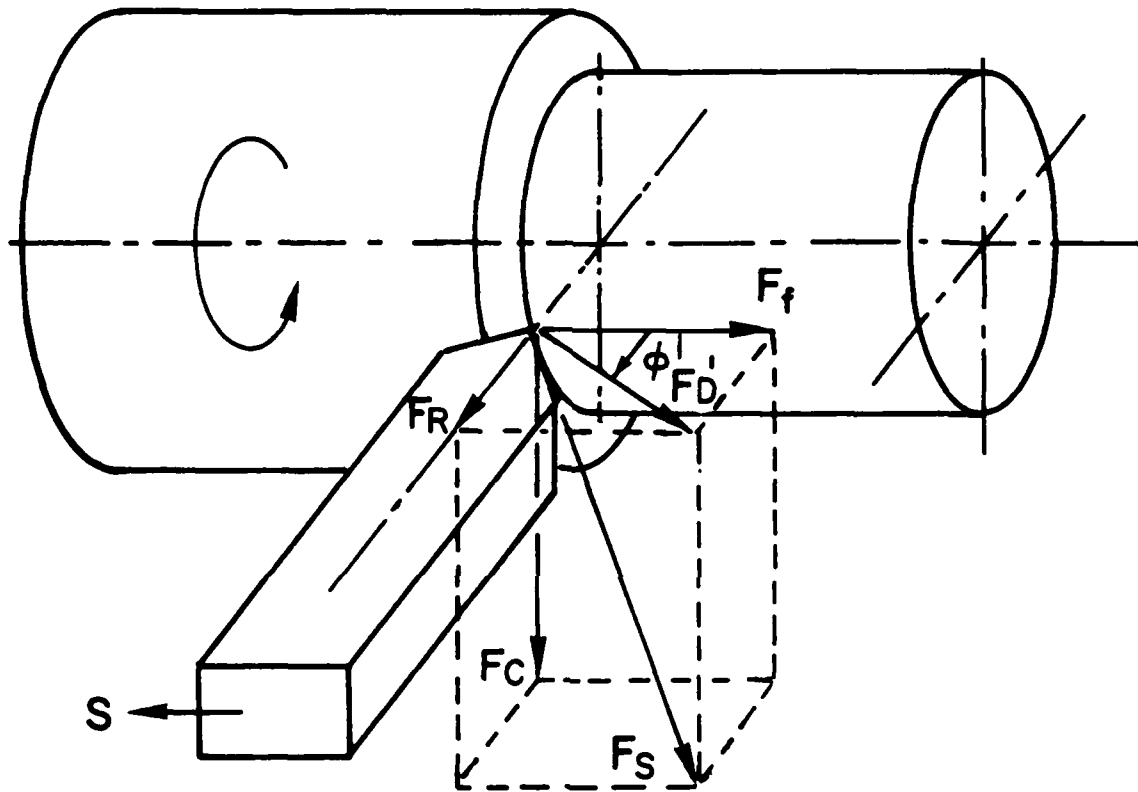

Fig. 18 — Geometry and cutting forces for a lathe tool. F_c is the cutting force, F_f is the feed force, and F_r is the radial force.

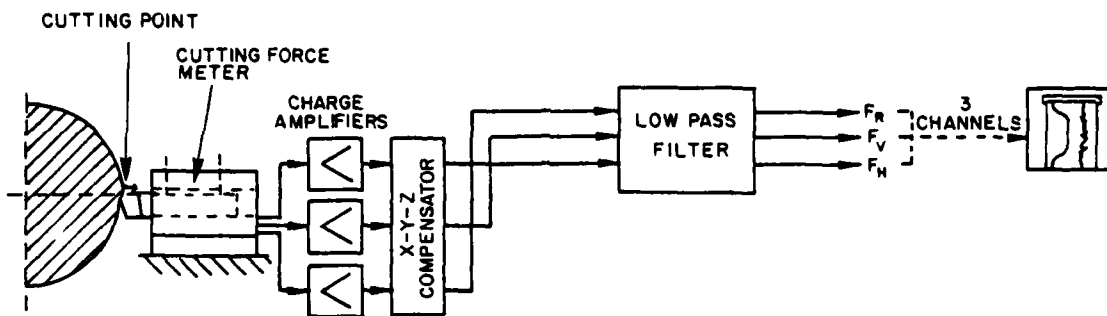
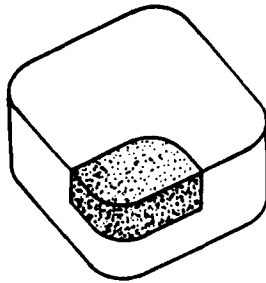
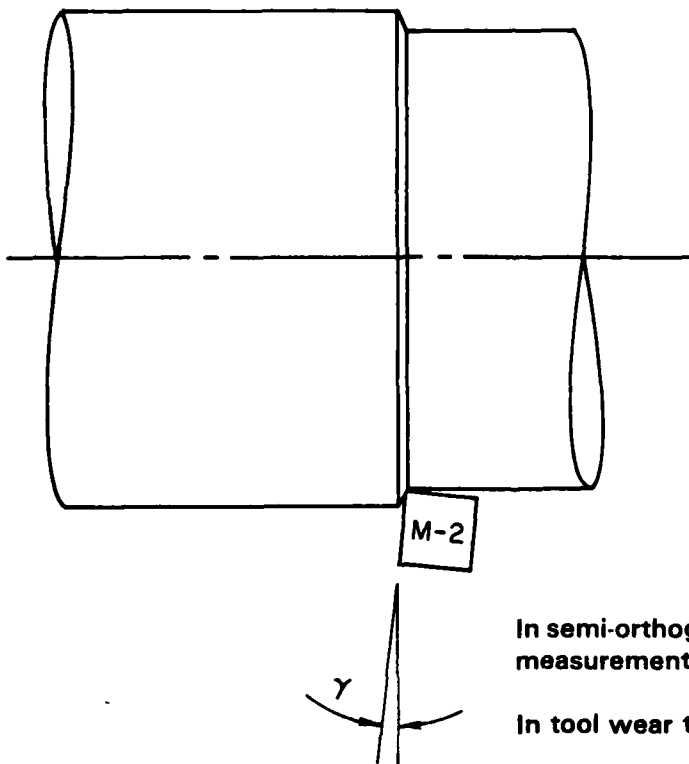

Fig. 19 — Block diagram showing the principal components of the system used to measure cutting forces on the lathe tool bit



Schematic illustration of ion implanted, $1/2'' \times 1/2''$ high speed steel tool inserts. Crater face and flank faces were implanted with 150 keV titanium ions. Implanted region is shaded.



In semi-orthogonal cutting tests for force measurements, $\gamma = 5^\circ$ was used.

In tool wear tests $\gamma = 15^\circ$ was used.

Fig. 20 — Geometry used for semi-orthogonal cutting tests

Test Results. Ion implanted M2 high speed steel inserts (6° positive rake) and TiC-coated cemented carbide inserts (6° negative rake) have been used to machine a medium carbon steel in an instrumented lathe. Measured force components have been used to determine the effective friction coefficient at the tool-chip interface during machining. An orthogonal cutting mode (simulation of two-dimensional cutting) was used for the high speed steel inserts and a semi-orthogonal cutting mode (oblique cutting) was used for the TiC-coated carbide inserts.

The test results obtained are summarized in Tables 3 through 5. They show the data from the orthogonal cutting tests for triple replication on the same bar of material. All three tests show a reduction in the cutting force for the ion implanted tools which is reflected in the lower power measurements for the tests. No consistent or discernable trends can be detected in the tool-chip interface effecting friction coefficients calculated for the tests.

Flank wear tests were carried out on the same lot of steel. The tests were carried out at a cutting speed of 33.5 m/min., with a depth of cut of 1.5 mm and a feed rate of 0.125 mm/revolution. The speed and feed were chosen to obtain a flank wear of the order of 0.2 mm in some 20 minutes of cutting tests (actual cutting time). The results obtained are shown in Fig. 21. While the unimplanted tool yielded a flank wear of approximately 0.25 mm in 10 minutes of cutting, the implanted tools did not produce a wear land of 0.20 mm in 20 minutes of cutting. The tests were run without lubrication.

Tool wear tests under controlled laboratory conditions unambiguously show that titanium ion implantation leads to a lowering of flank wear rate in M2 high speed steel tools.

Data for the TiC-coated carbide inserts is shown in Tables 6 and 7 and Fig. 22. The nitrogen, boron, and carbon implants were all done at two energies (75 and 150 keV) to broaden the implant profile. A dose of 2.5×10^{17} ions/cm² was implanted at each energy for all three ion species. The force measurement results show lower cutting forces for the carbon implanted tools at all cutting speeds and somewhat higher cutting forces for the nitrogen and boron implanted tools. The measured friction coefficients as shown in Table 6 are higher than the unimplanted tools at low cutting speeds but decrease to a value below the unimplanted tool at the upper end of the useful cutting speed range for TiC-coated carbide inserts (approximately 200 meters per minute). The specific power also appears to be lowered by ion implantation especially for the carbon implant. Further experiments are in progress to evaluate the effect of a higher temperature implant which should assist the formation of the refractory nitrides and borides.

Additional data of relevance to the current investigation but as yet unpublished were obtained by Carosella and Ramalingam. It is reproduced here with their kind permission. The material-implant systems were of two types. a straight 94WC-6Co grade implanted with carbon to harden the Co binder and a 94WC-6Co grade with a TiC coating which was a preliminary study of the effects of carbon, nitrogen, and boron on wear performance of TiC. The uncoated 94WC-6Co type is a "cast iron cutting grade" (CI) while the TiC coated type is typically used for the machining of steels. The CI cutting grade tool inserts, Carboloy Grade 895, were implanted with C⁺ at 25 and 50 keV. The TiC-coated tools were implanted with carbon, boron and nitrogen ions.

Unreplicated machining tests carried out on hot-rolled steel bars of AISI

Table 3 - Orthogonal cutting (two dimensional cuttings) test data. Comparison of implanted and unimplanted M-2 high speed steel tools. Width of cut = 2.54 mm and feed rate = 0.125 mm/rev. at indicated cutting speed.

Cutting Speed m/min	F_c Newtons	F_t Newtons	μ	ΔP %
<u>Datum: Unimplanted tool</u>				
20	859	368	0.56	
25	827	364	0.57	
30	788	355	0.58	
35	772	337	0.57	
40	756	328	0.56	
45	725	326	0.58	
50	693	309	0.58	
<u>Implanted Tool</u>				
20	789	355	0.59	- 8.14
25	749	337	0.58	- 9.43
30	725	327	0.58	- 7.99
35	693	319	0.59	- 10.23
40	678	314	0.60	- 10.31
45	662	309	0.60	- 8.68
50	638	305	0.61	- 7.93

Preliminary data indicates (column 5) that specific power consumption for metal removal is lowered by ion implantation.

Significant effect on 'friction' is not noted

Table 4 - Orthogonal cutting (two dimensional cuttings) test data. Comparison of implanted and unimplanted M-2 high speed steel tools. Width of cut = 2.54 mm and feed rate = 0.125 mm/rev. at indicated cutting speed.

Cutting Speed	F_c	F_t	μ	ΔP
m/min	Newton's	Newton's		%
<u>Datum: Unimplanted tool</u>				
20	847	405	0.61	
25	792	378	0.61	
30	764	369	0.62	
35	749	365	0.62	
40	733	360	0.63	
45	717	352	0.63	
50	693	338	0.62	
<u>Implanted Tool</u>				
20	804	352	0.57	- 5.07
25	768	343	0.58	- 3.03
30	744	334	0.58	- 2.61
35	725	325	0.58	- 3.20
40	697	312	0.58	- 4.91
45	678	307	0.59	- 5.43
50	662	303	0.59	- 4.47

Preliminary data indicates (column 5) that specific power consumption for metal removal is lowered by ion implantation.

Significant effect on 'friction' is not noted

Table 5 - Orthogonal cutting (two dimensional cuttings) test data. Comparison of implanted and unimplanted M-2 high speed steel tools. Width of cut = 2.54 mm and feed rate = 0.125 mm/rev. at indicated cutting speed.

Cutting Speed m/min	F_c Newtons	F_t Newtons	μ	ΔP %
<u>Datum: Unimplanted tool</u>				
20	851	409	0.62	
25	843	405	0.62	
30	804	378	0.61	
35	784	369	0.61	
40	756	365	0.59	
45	737	358	0.62	
50	721	356	0.63	
<u>Implanted Tool</u>				
20	717	334	0.60	- 15.74
25	693	332	0.61	- 17.79
30	662	320	0.62	- 17.66
35	646	318	0.63	- 17.60
40	642	316	0.63	- 15.07
45	640	307	0.60	- 13.16
50	634	303	0.61	- 12.06

Preliminary data indicates (column 5) that specific power consumption for metal removal is lowered by ion implantation.

Significant effect on 'friction' is not noted

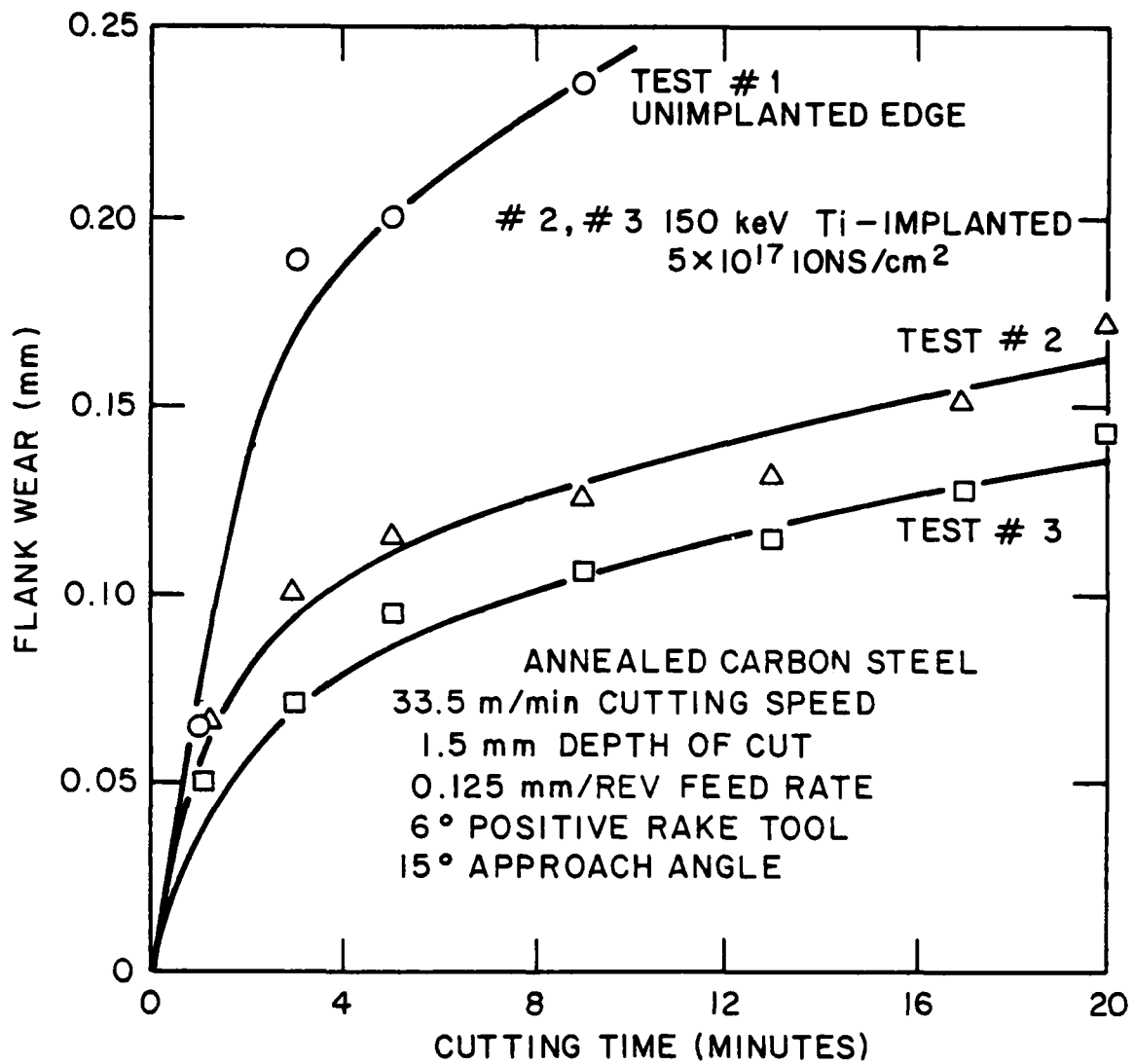

Fig. 21 - Comparison of tool wear characteristics of unimplanted and titanium implanted M2 high speed steel tool inserts

Table 6 - Effect of ion implantation on the tool-chip 'friction' during machining as a function of cutting speed. A medium carbon steel was machined with TiC coated WC tool inserts.

Cutting Speed meters/min	Measured friction coef. in semi-orthogonal cutting			
	Unimplanted	Carbon <u>implanted</u>	Boron <u>implanted</u>	Nitrogen <u>implanted</u>
100	.660	.725	.741	.734
130	.709	.704	.712	.728
160	.704	.695	.699	.713
190	.700	.686	.681	.693
220	.698	.664	.625	.685

Preliminary test data when machining a medium carbon steel.

Measured test data are shown in Figure 22 attached.

Table 7 - Effect of ion implantation on the specific power consumption* in machining. Percent change is tabulated with the unimplanted tool as the datum.

Cutting speed m/min.	Implanted Species		
	Carbon	Boron	Nitrogen
100	- 11.4	+ 2.3	+ 5.7
130	- 1.9	+ 4.6	+ 1.9
160	- 2.0	- 4.6	- 1.0
190	- 6.2	- 0.1	- 4.5
220	- 7.7	0	- 4.7

*Specific power
consumption

=

Power dissipated per unit
volume of metal removed.
Includes the deformation
and frictional component.

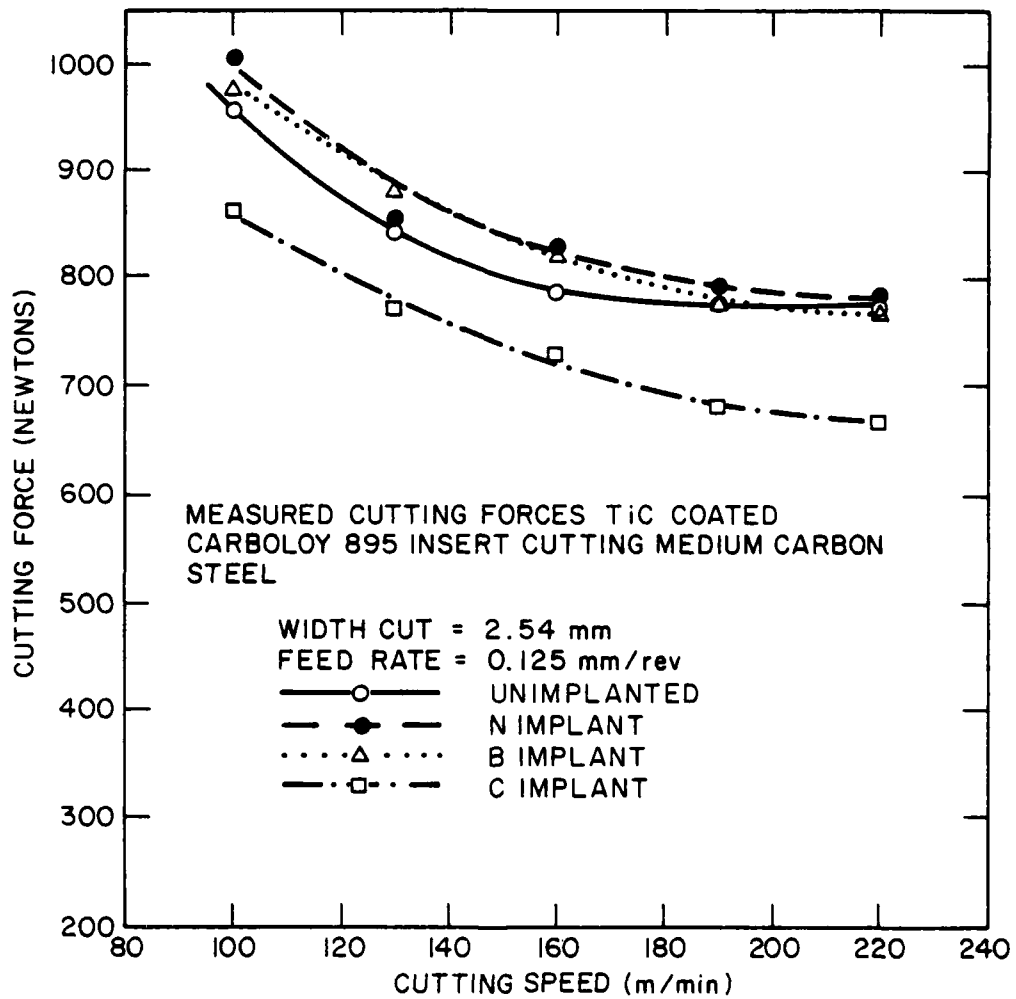

Fig. 22 — Comparison of the cutting force, F_c , measured on unimplanted and C implanted TiC coated tool bits of carboly grade 895 cemented tungsten carbide during machining of a medium carbon steel

1045 chemistry with implanted CI-grade tool inserts showed that carbon implantation had no significant effect either on the flank wear or on the crater wear (see Fig. 23). Typically, the wear tests were carried out at a cutting speed of the order of 100 m min^{-1} with a depth of cut of 1.5 mm and a feed rate of $0.125 \text{ mm Rev}^{-1}$. The carbon-implanted tools were found to lower the cutting forces by some 10 to 20 percent while machining cast iron as shown in Fig. 24.

The TiC-coated tools were tested by machining the same steel as in the case of uncoated tools. In this instance, the measured cutting forces are the same with and without implantation (Fig. 25). The 30-minute tool life tests (1.5 mm depth of cut; $0.125 \text{ mm Rev}^{-1}$ feed rate) show that while boron and nitrogen lower the flank wear rate, the carbon-implanted tool exhibits a higher wear rate (Fig. 26).

The above results from the instrumented lathe tests show some definite modifications in tool performance can be achieved by ion implantation. The M2 high speed implants with titanium lowered the cutting force and specific power requirements and reduced the rate of tool wear by a factor of two in the machining of annealed 4140 steel. Implants of TiC-coated cutting tools showed a less pronounced effect but may not have received the optimum heat treatment to produce a fully hardened coating. Previous experiments on C, N and B implants of TiC coatings had shown a 20 percent reduction in flank wear for the B and N implants when machining a hot rolled AISI 1045 steel.

C. Service Tests of Ion Implanted Tools

The final test of ion implantation as a means to improve wear resistance of metal cutting tools was the service testing of a selection of end mills and drills at FMC Corporation, Northern Ordnance Division, Minneapolis, MN. The tools selected for testing are shown in Fig. 27 following implantation with $4 \times 10^{17} \text{ Ti ions/cm}^2$. All the tools except the 7/16 in. diameter end mills were implanted from the side while rotating the tool. The 7/16 in. diameter mill was also implanted from the end.

The end mills were evaluated in typical service operations by noting the performance of implanted and unimplanted tools on identical machining operations with identical operating parameters. The machining applications are summarized in Table 8. Materials used in the tests were hot rolled AISI 4140 and cold forged AISI 4340 steels. A water soluble oil lubricant, "Trimsol," manufactured by Master Chemical Corporation of Perrysburg, OH, was used in all tests. The tool materials used in the service tests were designed to provide a limited comparison between an implanted tool and an unimplanted tool from the same manufacturer and the same lot of materials. In the case of the 7/16 in. diameter end mills both unimplanted controls broke under atypical conditions so no direct comparison is possible. The current stock tool, a Japanese product with a proprietary composition, was substituted. In the case of the 1/4 in. and 1 in. diameter end mills, Japanese products known to contain cobalt in some cases, were also added to the test for comparison purposes.

Observations of the wear performance are compared in Table 9. The tests were of two types. One performed with numerically controlled machines used the criteria that the tool bit was removed from service when the machine could no longer compensate for tool wear. Measures of wear in those tests were number of parts machined and the change in diameter of the tip of the tool. The other test involved machining under the observation of a machinist with the unimplanted tools pulled from service when the surface finish or chip formation characteristics indicated the tool cutting edge had deteriorated. The implanted tools were run for the same length of

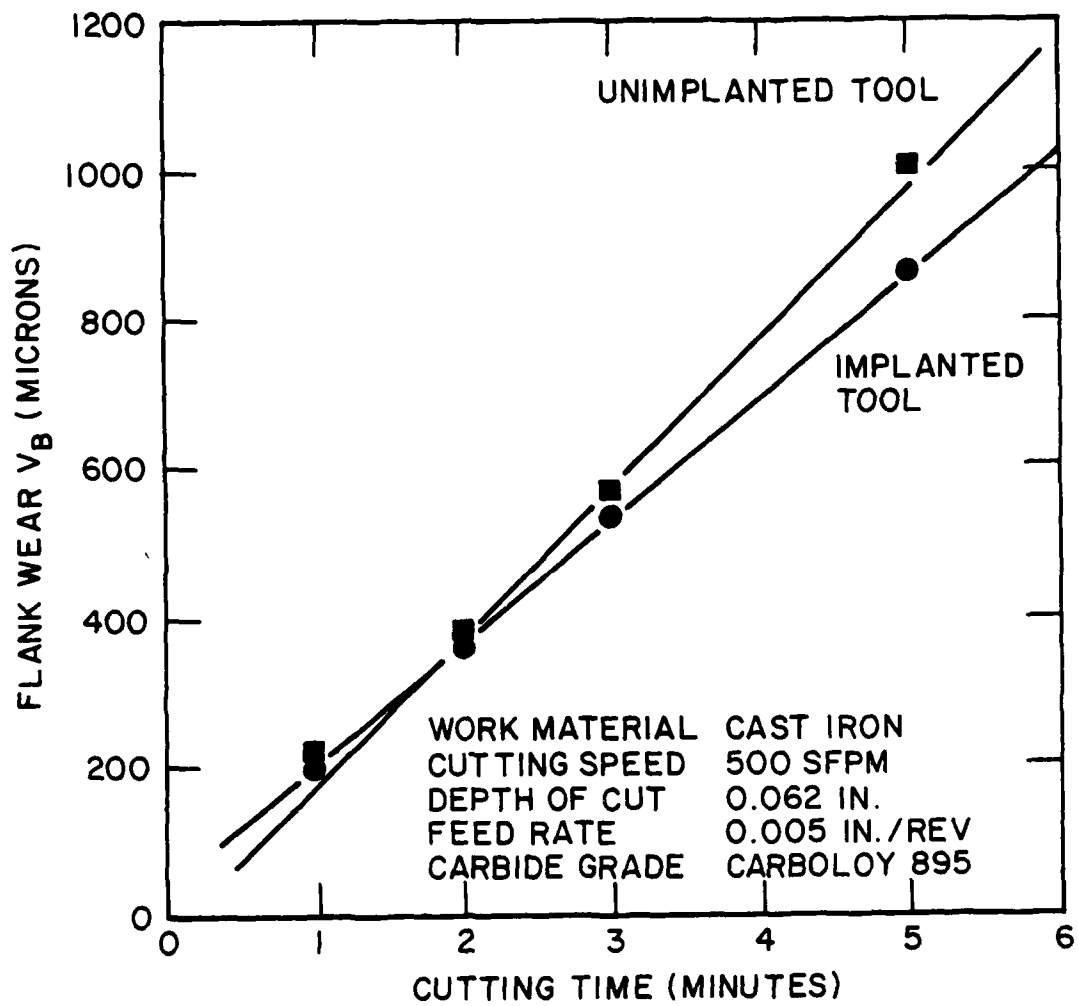

Fig. 23 — Effect of carbon implantation on flank wear while machining cast iron with 94WC-6 Co cutting tool

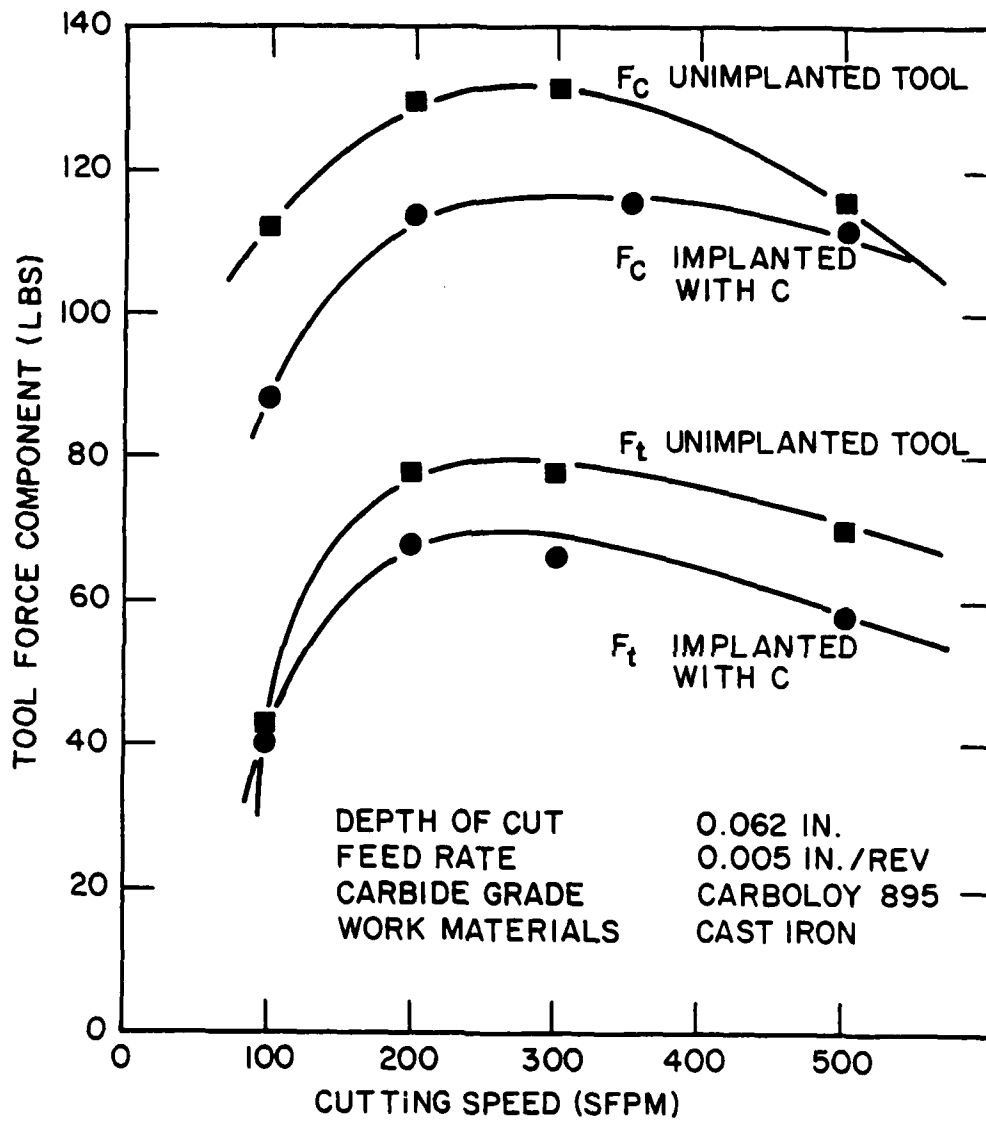

Fig. 24 - Cutting forces measured while machining cast iron with carbon implanted and unimplanted 94WC-6 Co cutting tool

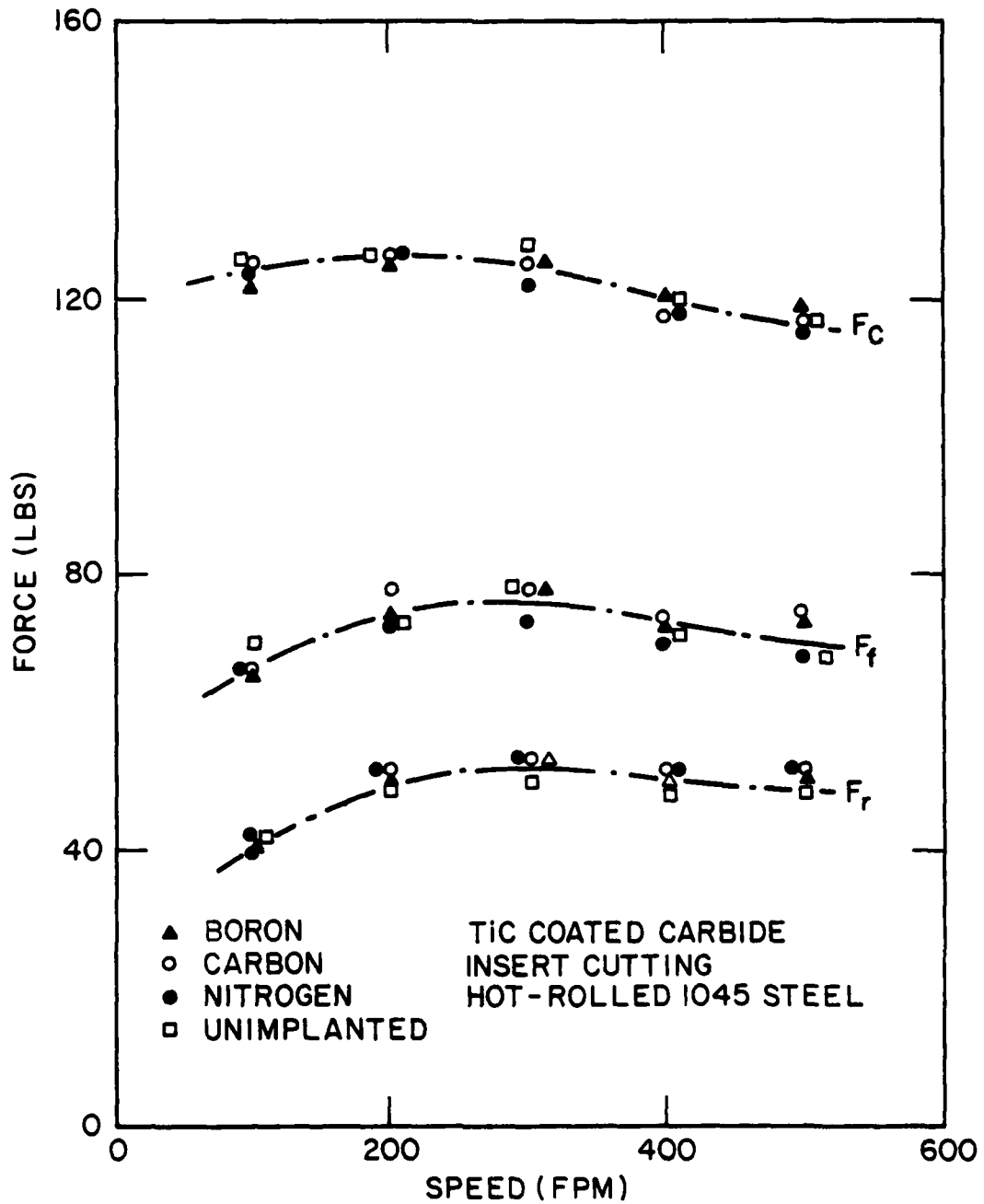

Fig. 25 — Cutting forces measured while machining hot-rolled 1045 steel with implanted and unimplanted TiC coated cemented tungsten carbide tool inserts

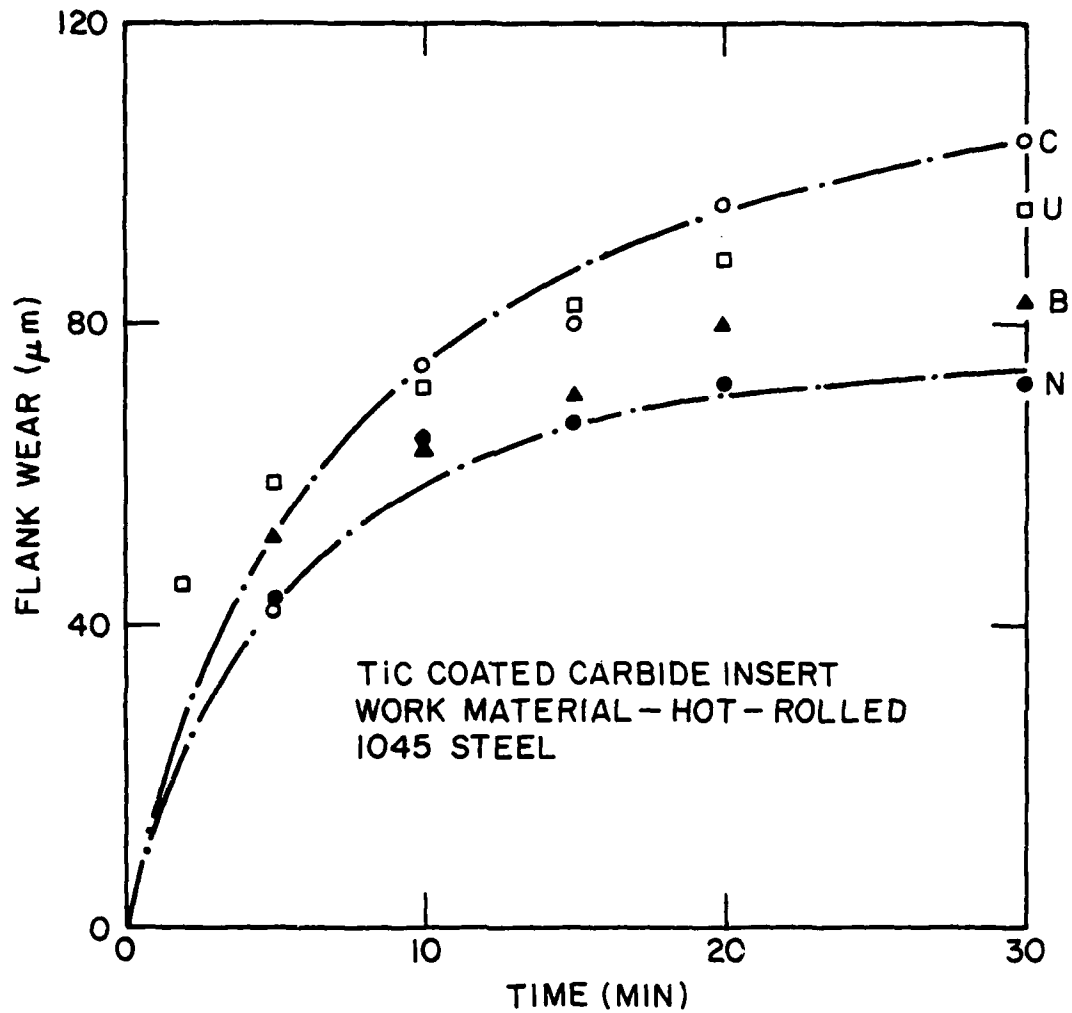
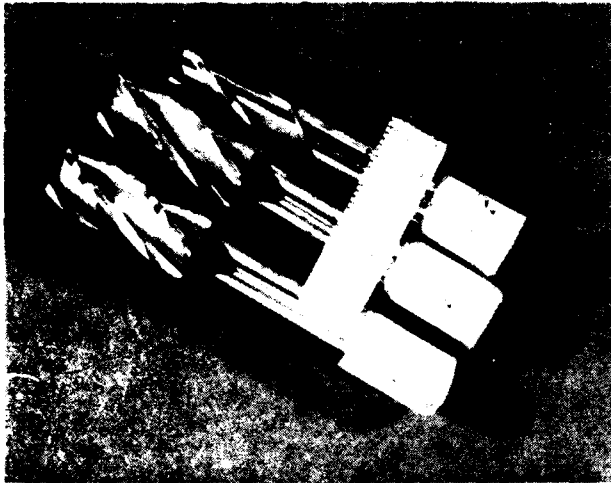

Fig. 26 - Effect of implantation on flank wear while machining a hot-rolled 1045 steel with TiC coated cemented tungsten carbide tool inserts



**7/16" DIAM. END MILLS
AND 1/4" DIAM. END MILL
IMPLANTED WITH
TITANIUM IONS.**

1 × PHOTO

**1" DIAM. END MILLS
IMPLANTED WITH
TITANIUM IONS
0.7 × PHOTO**

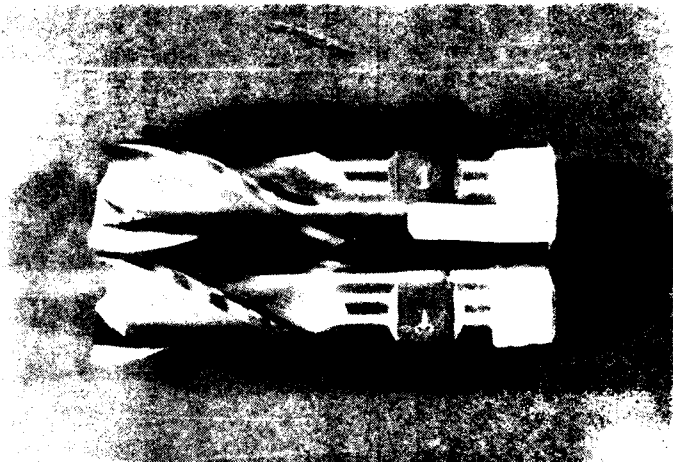

**1 1/8" DIAM. × 8" DRILL
IMPLANTED WITH TITANIUM
IONS**

0.36 × PHOTO

Fig. 27 — End mills and drills implanted with Ti for service tests of tools

R-142

TABLE 8

Machining Applications

Tool	Description of Machining Operation	Operating Parameters	Material
End Mill 7/16" - 4 flute	Face and Mill Slot Cut Parameters W = .438" d = .219 L = 40 - 65"	62 Surface ft./min Machining Speed 1.1 and 1.5 in./min Feed Rate	4140 HR Plate BHN 205-212 Trimisol Lubricant
End Mill 1/4" - 2 flute	Finish Mill Sides Ramp Cut Parameters d = .062" W = .125" L = 10"	58.9 Surface ft./min Machining Speed 2.3 in./min Feed Rate	E4340 CF Plate BHN 245 Trimisol Lubricant
End Mill 1" - 2 flute	Finish Mill and Face Cut Parameters W = .750" d = .125" L = 20"	65.5 Surface ft./min. Machining Speed 1-5 in./min Feed Rate	E4340 CF Plate BHN 245 Trimisol Lubricant
Drill 1-1/8" diam. x 8" long	Results not yet available.		

TABLE 9

Service Performance Tests

Tool Code Number	Condition ^a (I or U)	Hardness Rc	Tool Life	Diameter Change	Comments
<u>7/16" Diameter End Mill</u>					
1E	U (1.1 in./min) (Kobe Steel)	66.2	59 min	.004"	Poor finish-2 of 4 flutes chipped.
1F	U (1.5 in./min) (Kobe Steel)	66.2	26.7 min	.0015	Tool Failure-3 of 4 flutes chipped, shaft broke.
2A	I (1.1 in./min)	64.5	59 min.	.003	No failure.
2B	I (1.5 in./min)	64.8	26.7 min. +30.0 ^b	.0025 .0000	No failure. No failure.
<u>1/4" Diameter End Mill</u>					
3D ₁	U	65.1	14 parts	.003	Tests terminated. When numerical Control Machines could no longer compensate for tool wear.
3D ₂	U	63.3	13 parts	.003	
3C	U (Nipon Steel)	66.0	20 parts	.003	
3B	I	65.7	14 parts	.003	
<u>1" Diameter End Mill</u>					
1C	U (Kobe Steel 8%)	48.1	19 parts	.002	Tests terminated. When numerical Control Machines could no long compensate for tool wear
1D	U	66.9	17 parts	.001	
1A	I	64.8	14 parts	.001	
1B	I	65.8	14 parts	.003	

^aI - Implanted

^bTotal time = 56.7 Min.

U - Unimplanted

time (although they had not failed) and the tip diameter change measured.

The service tests showed mixed results. The most promising were those on the 7/16 in. diameter end mill where both unimplanted control specimens broke under atypical conditions (mill hit the case hardened section of the part). The two replacement tools, 1E and 1F, which had a slightly higher R_c hardness also failed because of chipping of the cutting edge. Tool 1F actually fractured in the shaft although this was undoubtedly induced by loss of the cutting edge. The implanted tools showed no indication of micro-chipping and one was run to twice the life of the unimplanted tool without a loss in quality of the finished product. The flute edges were examined in an SEM to determine if there were any apparent differences in the wear mode. Figure 28 shows a schematic of the region of the tool examined. The regions in the schematic diagram are most easily seen in the 100 x SEM photograph of the implanted tool in Fig. 29. The upper portion of the photograph with the deep grinding marks is on the section of the flute tapered for clearance and experiences no wear during the machining operation. The land is the 0.015 in. wide darker region from the cutting edge at the bottom of the photograph to the tapered section in the upper portion. Wear starts on the cutting edge and progressively extends across the land.

The most severe wear was on the cutting edge which in all cases was blunted. The unimplanted tool showed regions where the surface had cracked and spalled in sheets leaving rough craters behind as can be seen in the upper portion of Fig. 29. Surface cracks are also visible. This wear mode appears to be a form of surface fatigue failure. Tool 1E, which had a lower feed rate than 1F, did not show cratering but had a heavily worked surface at the cutting edge. The implanted tools, 2A and 2B, by contrast show no surface cracking or spalling but rather have more of a smeared metal appearance as can be seen in Fig. 29.

A comparison of the M7 1/4 in. diameter end mills, (Codes 3D₁, 3D₂ and 3B) showed the same performance for all three. A Nipon Steel product with proprietary composition showed substantially better performance. An optical examination of the cutting edge revealed no significant differences between the implanted and unimplanted M7 tools. Preliminary SEM examinations of the cutting edge on 3D₁ and 3B show the most severe wear is in a band 0.0034 in. wide along the cutting edge on the side of the flute. Heavy abrasive wear tracks are observed in this band with some evidence that carbides or other constituents of the microstructure have been gouged from the surface. The implanted tool 3B is very similar in appearance. The Japanese tool, 3C, has not yet been examined.

The 1 in. diameter M7 tools (1D, 1A and 1B) would tend to indicate the implanted tools had poorer performance with 14 parts produced as compared with 17 parts for the unimplanted tool. SEM examination of the worn cutting edges, however shows the wear rate as measured by the (width of worn region/No. of parts) to be the same for both implanted and unimplanted tools. Tool 1C, an 8 percent Co modification of M2 produced by Kobe Steel Company of Japan, showed substantially better performance than the non-cobalt containing materials as would be expected. The material is also unique in having a low hardness of only R_c 48 compared to the R_c 65-66 values expected for a quenched martensitic tool steel.

The observations from the service tests of the tools and SEM examinations of the cutting edges would indicate that implantation of M7 tool steel was not successful in producing a wear resistant surface layer. Abrasive wear erosion of the cutting edge was judged to be essentially the same for both implanted and unimplanted M7 end

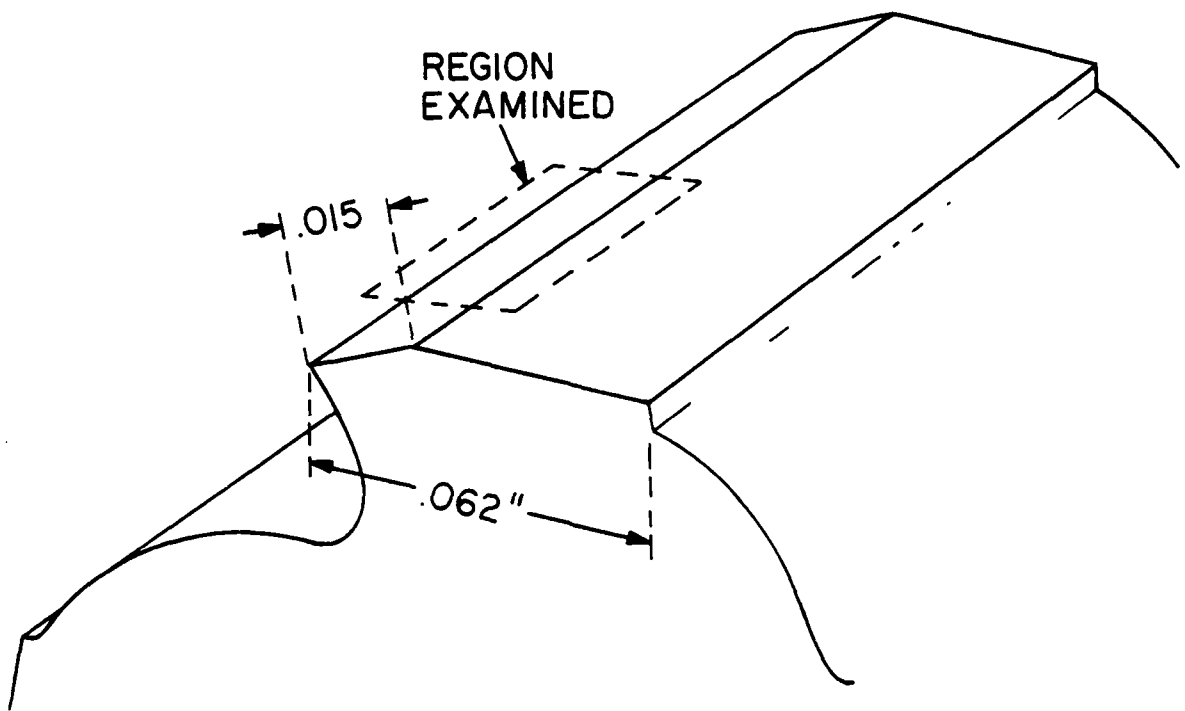
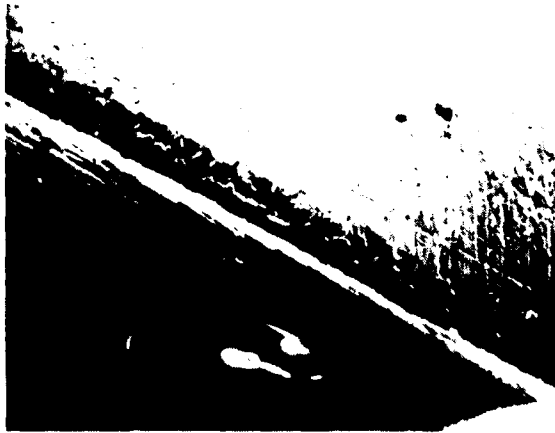

Fig. 28 — Schematic of region of flute examined in SEM photographs of Fig. 29. Wear occurs along the cutting edge and extends across the 0.015 in. wide land



100 ×



500 ×

UNIMPLANTED TOOL



100 ×

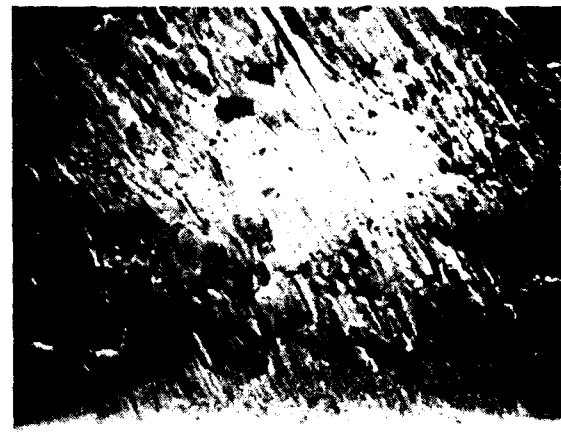

500 ×

IMPLANTED TOOL

Fig. 29 — SEM micrographs of worn flutes on specimens 1F and 2B of the 7/16 in. diam. end mill. The lower left hand photograph shows the principal regions starting from the cutting edge at the bottom, land with wear region extending up from the cutting edge, and lighter region on back of flute with grinding marks readily visible. The unimplanted tool (top) has cracked and chipped in the worn region while the implanted tool shows abrasive wear and plastic flow along the worn surface.

R-143

mills. Some benefit may have been achieved for the 7/16 in. end mill application in which unimplanted tools fractured under the same conditions for which the implanted tools did not fail although the difference in material may also be a factor. The above results for the end mills were somewhat at variance with the observations from the lathe tests so a check was made of one of the surfaces exposed to the ion beam to ascertain if a TiC surface layer had in fact been obtained. The preliminary results showed that a thin layer of TiC had formed but the Ti concentration and the thickness of the TiC layer were less than those which produced the beneficial effects in the AISI 52100 steel. Additional details of the analysis will be provided in a future progress report. The present service tests of tools are therefore inconclusive and must be repeated at higher Ti implant levels.

CONCLUSIONS AND RECOMMENDATIONS

Ion implantation as a surface treatment technique to improve the wear resistance of materials was severely tested in this evaluation of metal cutting applications. A concept of implantation with Ti ions and subsequent reaction to produce TiC had been shown to give significant improvements in the wear performance of AISI 52100 in both unlubricated and lubricated conditions for pin-on disk tests where the normal stress was approximately one half the yield stress of the material. In the instrumented lathe tests, stresses were estimated to approach to within 10 to 20 percent of the yield stress while SEM observations of the end mill cutting surfaces showed localized regions of plastic flow. Such high surface stresses cause severe wear and abrasion of the surface layer in relatively short times. In spite of the severe conditions, ion implantation did produce measurable and consistent improvements in instrumented lathe tests where the power consumption was approximately 10 percent less than for unimplanted tools, the cutting forces were consistently lower than unimplanted tools, and the flank wear rate was roughly one half that of the unimplanted tools. The 7/16 in. diameter end mill implanted on all surfaces also showed improved performance by virtue of preventing failure of the tools by chipping and microcracking. The above effects suggest that ion implantation is modifying the surface layers involved in sliding wear. Other implant species which provide surface lubrication or are conducive to the formation of lubricating surface oxides should be explored as well as additional characterization of the wear mode and improvements in the post-implant reaction process to form TiC in alloy tool steels.

The fact that some beneficial effects of ion implantation were observed under these severe unlubricated wear conditions helps establish the efficacy of ion implantation as a surface wear treatment for lighter load, lubricated conditions such as rolling contact bearings, electrical contacts, and slip rings. The inconclusive end mill service tests need to be repeated with a higher Ti implant level to determine if the implanted cutting edge can withstand wear when conditions are optimum for formation of a thicker layer of TiC.

ACKNOWLEDGMENTS

This evaluation was performed with funding provided by Naval Sea Systems Command, Surface Warfare Systems Division. The authors wish to thank Mr. G. Brown/NAVSEA062 for his assistance and encouragement, Mr. E. Wigand and Mr. D. Brazys of FMC Corporation, Northern Ordnance Division, for providing the service tests of the implanted tools, and Mr. J. Reed, NRL, for performing the SEM examination of the tools.

REFERENCES

1. M. C. Shaw, "Principles of Material Removal," Vol. 1, ICM-3, Cambridge, England, pp. 227-253, August 1979.
2. "Ion Implantation as a New Surface Treatment Technology," National Materials Advisory Board Report, NMAB-349, Washington, DC (1979).
3. G. Dearnaley, "Practical Applications of Ion Implantation" in Ion Implantation Metallurgy, D. M. Preece and J. K. Hirvonen (Eds.), Metallurgical Society of AIME, Warrendale, PA, pp. 1-20, 1980.
4. E. M. Trent, "Wear of Metal-Cutting Tools," in Wear, Vol. 13, Treatise on Materials Science and Technology, D. Scott (Ed.), Academic Press, New York, pp. 443-488, 1979.
5. N. P. Suh, "New Theories of Wear and Their Implications for Tool Materials," Wear, Vol. 62, pp. 1-20, 1980.
6. ASM Handbook Committee, "Materials for Cutting Tools," Vol. 3, Machining, 8th Edition, Metals Handbook, American Society for Metals, Metal Parks, OH, pp. 311-332, 1967; "Wear Resistance" in Vol. 1, Properties and Selection: Iron and Steels, 9th Edition, Metals Handbook, American Society for Metals, Metals Park, OH, pp. 597-638, 1978.
7. S. Ramalingam and J. D. Watson, "Inclusion Chemistry Control for Machinability Enhancement in Steels," Materials Science and Engineering, Vol. 43, pp. 101-108, 1980.
8. S. Ramalingam and G. Faulring, "An Experimental Validation of the Abrasive Tool Wear Theory and the Conceptual Design of Ferrous Alloys for Machinability," Proceedings of the 6th North American Metal Working Research Conference, Gainesville, FL, 1978, Soc. Manuf. Engrs., Detroit, MI, pp. 290-297, 1978.
9. T. S. Eyre, "Wear Resistance of Metals," in Wear, Vol. 13, Treatise on Materials Science and Technology, D. Scott (Ed.), Academic Press, New York, pp. 363-441, 1979.
10. R. H. Philipson and A. Ravindran, "Application of Mathematical Programming to Metal Cutting," Mathematical Programming Study 11, pp. 116-134, 1979, North Holland Publishing Co., The Netherlands.
11. C. A. Carosella, I. L. Singer, R. C. Bowers and C. R. Gossett, "Frictional Wear Reduction of Bearing Steel via Ion Implantation" in Ion Implantation Metallurgy, C. M. Preece and J. K. Hirvonen (Eds.), Metallurgical Society of AIME, Warrendale, PA, pp. 103-115, 1980.
12. I. L. Singer, C. A. Carosella, and J. R. Reed, "Friction Behavior of 52100 Steel Modified by Ion Implanted Ti," Proceedings, Ion Beam Modification of Materials Conference, Albany, NY, July 1980.
13. J. A. Sprague, Naval Research Laboratory, private communication, 1980 (see also Ref. 12).

14. S. Ramalingam, Georgia Inst. of Tech., private communication on Strengthening Concepts for TiC, October 1980.
15. K. Langhammer, "Cutting Forces as Parameters for Determining Wear on Carbide Lathe Tools and as Machinability Criterion for Steel," The Carbide Journal, May-June 1976.

BLANK PAGE

