

AD A105082

13

AVRADCOM

Technical Report - 79-0270-F

ELECTRONIC MASTER MONITOR AND ADVISORY DISPLAY SYSTEM
(EMMADS)

GENERAL ELECTRIC COMPANY
AIRCRAFT EQUIPMENT DIVISION
BINGHAMTON, NY 13902

JUNE 1981
FINAL REPORT FOR PERIOD COVERING JUN 77 - JUN 81

DISTRIBUTION STATEMENT
Approved for public release;
distribution unlimited.

PREPARED FOR:
AVIONICS R&D ACTIVITY

DTIC
ELECTE
OCT 6 1981
S A

DTIC FILE COPY



Research and Development Technical Report
Aviation Research and Development Command

81 10 5 048

NOTICES

Disclaimers

The citation of trade names and names of manufacturers in this report is not to be construed as official Government indorsement or approval of commercial products or services referenced herein.

Disposition

Destroy this report when it is no longer needed. Do not return it to the originator.

UNCLASSIFIED

SECURITY CLASSIFICATION OF THIS PAGE (When Data Entered)

REPORT DOCUMENTATION PAGE		READ INSTRUCTIONS BEFORE COMPLETING FORM
1. REPORT NUMBER AVRADCOM-TR-79-0270-F	2. GOVT ACCESSION NO. AD-A105082	3. RECIPIENT'S CATALOG NUMBER (9) Final report
4. TITLE (and Subtitle) Electronic Master Monitor and Advisory Display System (EMMADS)	5. TYPE OF REPORT & PERIOD COVERED R&D June 77 - June 81	6. PERFORMING ORG. REPORT NUMBER ACS-12-386
7. AUTHOR(s) 12	8. CONTRACT OR GRANT NUMBER(s) 15 DAAK-80-79-C-0270 ✓	9. PERFORMING ORGANIZATION NAME AND ADDRESS General Electric Co. Aircraft Equipment Division Binghamton, NY 13902
10. PROGRAM ELEMENT, PROJECT, TASK AREA & WORK UNIT NUMBERS 16 1L2-62202-AH85-03-12-31	11. CONTROLLING OFFICE NAME AND ADDRESS Avionics R&D Activity Communications Sensors Instrumentation Div Fort Monmouth, NJ 07703	12. REPORT DATE June 1981
13. NUMBER OF PAGES 36	14. MONITORING AGENCY NAME & ADDRESS (if different from Controlling Office) 17	15. SECURITY CLASS. (of this report) UNCL
16. DISTRIBUTION STATEMENT (of this Report) Approved for public release, distribution unlimited.		
17. DISTRIBUTION STATEMENT (of the abstract entered in Block 20, if different from Report)		
18. SUPPLEMENTARY NOTES		
19. KEY WORDS (Continue on reverse side if necessary and identify by block number) Aircraft, Subsystems, Advisory Displays, Monitors, Fault Detection, Multi-legend Switches, Data Bus		
20. ABSTRACT (Continue on reverse side if necessary and identify by block number) This final report documents the work performed under contract DAAK-80-79-C-0270 (Electronic Master Monitor and Advisory Display System). It supplements other contract reports for the various tasks of the program.		

TABLE OF CONTENTS

<u>Section</u>	<u>Page</u>
1.0 INTRODUCTION	1
1.1 GENERAL	1
1.2 REFERENCED DOCUMENTS	1
1.3 CONTRACT OBJECTIVE	3
1.4 CONTRACT TASKS AND DOCUMENTATION	3
2.0 TASK I SUMMARY - SIGNAL ANALYSIS	5
2.1 SUBSYSTEM REQUIREMENTS	5
2.2 SUBSYSTEM INTERFACES	5
2.3 SUBSYSTEM ANALYSIS	6
3.0 TASK II SUMMARY - HFE PROGRAM	11
3.1 HFE PROGRAM PLAN AND TEST PLAN	11
3.2 HFE TESTING RESULTS	11
3.3 MISSION WORKLOAD ANALYSIS AND LITERATURE REVIEW	12
3.4 INFORMATION REQUIREMENTS ANALYSIS	13
4.0 TASK III SUMMARY - DATA TRANSMISSION	17
4.1 SYSTEM REQUIREMENTS	
4.2 RECOMMENDATIONS	17
5.0 TASK IV SUMMARY - HARDWARE	18
5.1 PRECONTRACT BASELINE	18
5.2 CONTRACT EXPANSION - SYSTEM EXERCISER	18
5.3 EVOLVING HARDWARE	19
5.4 DISPLAY PROCESSOR	20
5.5 OPERATIONAL SOFTWARE	25
5.6 EMMADS SYSTEM ARCHITECTURE	26
6.0 CONTRACT COST AND SCHEDULE	32
6.1 CONTRACT FUNDING	32
6.2 CONTRACT SCHEDULE	32

LIST OF ILLUSTRATIONS

<u>Figure</u>		<u>Page</u>
1	SUBSYSTEM PARAMETER DATA LIST	7
2	IN HOUSE PILOT SURVEY	14
3	ENGINE SYSTEM DISPLAY	15
4	FEASABILITY MODEL DISPLAY UNIT	21
5	TERMIFLEX ALPHA/NUMERIC KEYBOARD	22
6	MCP-701A RASTER SYMBOL GENERATOR	23
7	DISPLAY PROCESSOR BLOCK DIAGRAM	24
8	EMMADS BLOCK DIAGRAM	27
9	EMMADS FEASABILITY HARDWARE	28
10	CH-47C HELICOPTER	29
11	CH-47C INSTRUMENT PANEL	30
12	EMMADS INSTALLED IN PANEL	31
13	PROGRAM SCHEDULE	33

1.0 INTRODUCTION

1.1 GENERAL

The following final report is submitted to document the work done under contract DAAK 80-79-C-0270 Electronic Master Monitor and Advisory Display System (EMMADS). It supplements other reports for the various tasks of the program. Those reports will be referred to where appropriate, and should be considered as part of this report. Due to the size of some of these reports they are not physically attached.

1.2 REFERENCED DOCUMENTS

The following General Electric reports were generated during the performance of the contract. By reference they are a part of this document.

ACS 12,217 June 1981	Electronic Master Monitor and Advisory Display System (EMMADS) Operational Functions Report
ACS 12,385 June 1981	Electronic Master Monitor and Advisory Display System (EMMADS) Human Engineering Summary Report
ACS 12,177 August 1980	Electronic Master Monitor and Advisory Display System (EMMADS) Data Transmission Study
ACS 12,383 June 1981	Non-Complex Item Development Specification for a Feasibility Model of an Electronic Master Monitor and Advisory Display System (EMMADS)
ACS 12,388 June 1981	Electronic Master Monitor and Advisory Display System (EMMADS) Test and Demonstration Report

The following additional documents and items were generated during the performance of the contract. The contents or results are included in the documents noted above.

ACS 11,960 (Rev A) September 1979	Electronic Master Monitor Advisory Display System (EMMADS) Human Factors Engineering Program Plan
ACS 11,991 November 1979	Electronic Master Monitor and Advisory Display System (EMMADS) Human Factors Engineering Test Plan
	Monthly Progress Reports
	Meeting Reports and Slide Material

1.3 CONTRACT OBJECTIVE

The Contract objective is the design and fabrication of a programmable feasibility model of an EMMADS based on a conceptual study. At the program kickoff meeting the Army reinforced the two parts of this objective and directed that EMMADS was not intended to be a hardware development contract; the program emphasis was to be on developing information transfer methods which would reduce pilot workload.

1.4 CONTRACT TASKS AND DOCUMENTATION

The EMMADS statement of work contains four (4) tasks. The documents referenced in 1.2 relate to the work done in each of these tasks, as amplified below.

1.4.1 Task I - Signal Analysis

This was a systems engineering task with the goal of determining the EMMADS functional requirements and the sensor interfaces for the helicopters to be studied. The results of this work are included in the Operational Functions Report (ACS 12,217 Rev. A), June, 1981.

1.4.2 Task II - Human Factors Engineering Program

The goal of the HFE program was to develop formats which would minimize crew workload and maximize crew performance. Human Factors Engineering Program and Test Plans were prepared and submitted. The results of these tests and studies are contained in the Human Factors Engineering Summary Report (ACS 12,385, June 1981)

1.4.3 Task III - Data Transmission

The intent of this task was to analyze various methods of data transfer from sensors to an EMMADS system and recommend

appropriate interfaces and data transmission media. The results of this task are contained in the Data Transmission Study (ACS 12,177, August 1980).

1.4.4 Task IV - Hardware

The last task was the design and test of hardware to implement EMMADS as a programmable feasibility model for a CH-47C helicopter. This included a sensor simulator to exercise the system via a MIL-STD-1553B interface bus. The system description and test of this hardware is included in the Development Specification (ACS 12,383, June 1981), and the Test and Demonstration Report (ACS 12,388, June 1981). Additional details of the hardware are included in this final report.

2.0 TASK I SUMMARY - SIGNAL ANALYSIS

2.1 SUBSYSTEM REQUIREMENTS

Four types of helicopters were studied for this program: Cargo (CH-47C), Utility (UH-60A), Scout (OH-58C) and Attack (YAH-64). The CH-47C utilizes conventional interfaces and instruments and was the target helicopter for the EMMADS feasibility hardware and software. The UH-60A contains modern instrumentation, but the sensors are conventional, as are the interfaces. The OH-58C is a very austere helicopter. Size and weight restrictions limit the number and complexity of its subsystems and instruments. The original attack helicopter specified was the AG-1. However, early in the program the Army requested this be changed to the YAH-64. General Electric agreed to this change. The YAH-64 represents the most advanced subsystems and interfaces. This helicopter also already has a MIL-STD-1553 multiplex data bus. The change introduced a contrast in the data and systems efforts between conventional and new helicopter systems. However, complete data was not available in some areas since the helicopter was still in the development/flight test phase. Therefore less sensor data was tabulated for that helicopter than for the other three.

2.2 SUBSYSTEM INTERFACES

Data was gathered mainly from helicopter manuals, but additional data was gathered from pilot surveys, aircraft manufacturer visits (YAH-64) and the contract reports from the Subsystem Status Monitor contract.

The helicopter subsystems were organized into the following subsystems groups; Engine, Fuel, Powertrain, Hydraulic, Electrical, Miscellaneous, and Auxiliary Power Unit. Subsystem Parameter Data Lists were prepared for each of the helicopters and are contained in the Operational Functions Report. The CH-47C data is also repeated as part of the Development Specification. Figures 1a to 1d are representative of those lists. Observe that parameters were characterized by standard indicator and operating conditions, and that extensive notes were used to include related information.

2.3 SUBSYSTEM ANALYSIS

The operational functions were defined by subsystems for various flight modes. This analysis was done in conjunction with the human factors tasks and pilots surveys. The results are a part of the Operational Functions Report. One unexpected result was the insensitivity of the "display by exception" information requirements to helicopter types and flight modes. While the display of routine checklists relate to specific functions and flight phases, the need to display any given fault is, for the most part, independent of flight phase.

HELICOPTER: CH-47C
SUBSYSTEM: Fuel

DRAFT

Table: A2
Sheet No.: 1

PARAMETER NAME - INDICATOR LABEL	INDICATOR		MARKINGS	UNITS	OPERATING MODE	CONDITION	PARAMETER		NOTE # (SH 2)
	TYPE	RANGE					CONDITION TYPE - DURATION	REFERENCES (TM 55-1520-227)	
Fuel Quantity In the Aft, Main and Fuel Tanks on both the Left & Right Sides -	Circular Dial w/Pointer & Selector Switch	0-2300	None	lbs	All	0-(320-420) (320-420)-6840	Cautionary - unspecified Normal - continuous	-10-2, pp 2-31/32, 53, 56 & 71 -23-3, p F0-24 -23-5, p F-69	1
FUEL QUANTITY L(R) AFT, MAIN, FWD	No pointer indication but continuous digital readout on dial. Independent of selector sw position.	0-9999							
L(R) FUEL LOW	Caution Lgts (2)	--	Amber			<(320-420)	Cautionary - unspecified		2
Engine Fuel Line Pressure -	Caution Lgts (2)	--	Amber	psi	Pressure altitude <6000'	<10	Cautionary - unspecified	-10-2, pp 2-31/32 & 70 -23-4, p F0-33	3
L(R) FUEL PRESS					Pressure altitude >6000'		Warning - none allowed		
Auxiliary Tank Fuel Boost Pump Pressure -	Press to Test Caution Lgts (2)	--	Amber	psi	All	<(9-11)	Cautionary - unspecified	-10-2, pp 2-32 -23-4, p F0-33 -23-5, p F-149	4
AUX PRESS LEFT (RIGHT) SIDE									

Figure 1a. Subsystem Parameter Data List

DRAFT

Table: A2 (Fuel - Cont'd)

NOTES:

1. Sensors are ten capacitance type probes, three in each main tank and one in each auxiliary tank. The three probes in each main tank are wired in parallel, with one of the resulting twin lead-outs from each tank wired to the selector switch, while the remaining lead-outs are tied together at the indicator. For the auxiliary tank probes, one line from each probe is connected to the selector switch and the other lines are tied together at the indicator. The cautionary range specification is based on the low fuel caution light threshold and not on a dial marking. Note that tank capacities are all different, even for like tanks (TMS-1520-227-10-2, p 2-75).
2. Sensors are thermistor bead type units (A608 - Right and A609 - Left) at the lower end of the center fuel quantity probes (MT 604 and MT 609) in the main tanks. The signal is routed to the thermistor control unit (A142) which signals the caution panel when a main tank is down to about 20% of its capacity (see reference quoted in Note 1 above).
3. Sensors are pressure switches between the aft auxiliary tank and the engine fuel valves. The switch closes a path from the caution panel to ground when the low pressure threshold is reached. Operation above 6000' pressure altitude with the light on is likely to cause an engine flameout.
4. Sensors are four pressure switches, one for each auxiliary boost pump. The pressure switches on the same side of the aircraft are wired to the same light, but through the separate auxiliary boost pump switches (via a separate set of contacts in each switch) for that side. Thus, the pressure loss may be tracked to the specific line by alternately turning ON and OFF the fwd and Aft Auxiliary Boost Pump switches for the affected side. Since power to the lights is through breakers which protect the pump relay power lines (see Table A5) a tripped circuit breaker would cause a fuel pressure loss with no light to show such loss.

Figure 1b. Subsystem Parameter Data List

HELICOPTER: UH-60A
SUBSYSTEM: Engine

DRAFT

Table: 81

Sheet No.: 1

PARAMETER NAME - INDICATOR LABEL	INDICATOR		UNITS	OPERATING MODE	CONDITION	PARAMETER		REFERENCES (TH 55-1520-237)	NOTE # (SH 4)
	TYPE	RANGE				MARKINGS	CONDITION TYPE - DURATION		
Engine Power Turbine Speed - % RPM 1 (2)	Segmented Vertical Light Bar	0-130	(0-91)R (91-96)A (96-101)G (101-105)A (105-130)R	A11	91	Minimum - none except transients and idle (however, operation in 25-405 and 60-75% range is prohibited).	-10, pp 2-32, 5-2 & 5-6 -23-2, pp 6-69, 12-5 & 14-1 -23-3, pp 46-24/25	1	
					91-96	Caut ionary - transient			
					96-101	Normal - continuous			
					101-105	Caut ionary - 30 minutes			
					105-107	Warning - transient (12 sec)			
107	Maximum - 12 sec								
Engine Gas Producer Speed - Mg SPEED 1 (2)	Segmented Vertical Light Bar w/Digital Readout	0-110	(0-98)G (98-102)A (102-110)R	Eng Cond Lever in IDLE, Eng Started	52-55	Normal - continuous	-10, pp 5-4 -23-2, pp 3-16, 6-68 & 13-1	2	
					52-98	Normal - continuous			
					98-102	Caut ionary - 30 minutes			
					102-105	Warning - transient (12 sec)			
					105	Maximum - 12 seconds			
#1(02) ENG OUT	Master Warning Lights (2) Steady Tone In ICS	0-950	Red --	A11	455	Warning (possible flame out) - continuous	-10, p 2-57 -23-2, pp 6-69, 6-78 & 13-3 -23-3, pp 46-5, 24, 25 & 31	3	
					0-775	Normal - continuous			
Engine Turbine Gas Temperature - TGT TEMP 1 (2)	Segmented Vertical Light Bar w/Digital Readout	0-950	(0-775)G (775-850)A (850-950)R	A11	0-775	Normal - continuous	-10, p 5-3 -23-2, pp 3-13, 6-68, 12-1 & 13-1	4	
					775-850	Caut ionary - 30 minutes			
					850-886	Warning - Transient (12 sec)			
					986	Maximum - 12 seconds			

Figure 1c. Subsystem Parameter Data List

DRAFT

Table: B1 (UH-60A, Engine - Cont'd)

Sheet No.: 4

NOTES:

1. Sensor is a tachometer type whose variable frequency output is converted to a d.c. voltage by the SDC Interface No. 2 module.
2. Same type of sensor as note 1 above, with conversion via the SDC Interface No. 1 module.
3. The signal is derived from the Mg speed sensor described above, via the SDC. The SDC provides signals to the voltage regulator card of the CDU which then outputs the signals which actuate the warning lamps. The signals are routed back through the SDC connectors (but are not conditioned by the SDC) and then directly to the capsules in the pilot's and copilot's master warning panel and to the LH relay panel for routing to the ICS.
4. Seven thermocouple probes provide direct temperature sensing. Their outputs are averaged and routed to the SDC which first compensates for ambient temperature changes and then conditions the signal at the SDC Interface No. 4 module before routing to the CDU for display.
5. The sensor is of an unspecified type which provides a signal, proportional to the amount of twist on the power turbine shaft, to the SDC Interface No. 2 module.
6. A variable resistance type sensor is used, the output of which is transformed into a d.c. voltage by the Interface No. 2 module of the SDC.
7. Using the same sensor signals as above, the signal to the caution panel is produced by the CDU Voltage Regulator and routed to caution/advisory panel channel cards A1 and A2, via the SDC connectors (although the SDC does not operate on the signal).
8. Sensor output is 400 Hz ac voltage which is routed to the SDC Interface No. 4 module. It is combined there with a 10 vac 400 Hz reference (from the logic power supply) to produce a d.c. voltage proportional to the engine oil pressure, which is then routed to the CDU for display.
9. The sensor is the same as for the note above. However, when this signal reaches the CDU it is routed to the Voltage Regulator (as well as to the actual oil pressure display units) which conditions and compares the signal to determine when a low oil pressure condition exists. The output signal resulting from that comparison is then routed to caution/advisory panel cards A1 and A2, via the SDC connectors (although the SDC does not operate on the signal).
10. Sensors are contacts, one of which is connected to ground and the other is wired to caution/advisory panel card A3. The contacts are bridged by metal chips and the ground sensing (with subsequent capsule illumination) is performed inside the panel, presumably by the card.
11. Sensors are pressure switches connected to caution/advisory panel cards A1 and A2.
12. Sensors are switches which are either on or off depending on the valve position. Routing of the #1 (2) signals is through caution/advisory panel cards A2 and A3 respectively.
13. Sensors are temperature sensitive switches wired to caution/advisory channel card A3. Although there is no duration specified in the manuals listed, additional checking should be done to confirm no limitation is imposed due to a high O-A.T.
14. Sensors are switches which detect start control valve position. Wiring for #1 (2) switch is through caution/advisory panel channel card A1 (A2).

Figure 1d. Subsystem Parameter Data List

3.0 TASK II SUMMARY - HFE PROGRAM

3.1 HFE PROGRAM PLAN AND TEST PLAN

The HFE Program Plan was issued in August 1979. It was reviewed by the Army and several recommended changes were then incorporated by General Electric. The major change was to use the Subsystem/Parameter Data from the Subsystem Status Monitor (SSM) Task I report as a baseline for subsystem data and requirements. The revised plan was issued in September 1979.

The HFE Test Plan was issued in November 1979. The first phase included basic testing to evaluate fundamental attributes of analog and digital display formats. The last phase included composite testing to combine those basic elements into sample formats to allow pilot survey of the information content. The results are included in the Human Engineering Summary Report.

3.2 HFE TESTING RESULTS

Basic HFE testing was conducted to evaluate various attributes of symbology. Attributes tested included:

- o Analog orientation - horizontal versus vertical
- o Analog format - scale and pointer versus bar; hollow versus solid bars and pointers
- o Analog and digital location - digital remote versus digital adjacent to analog pointers
- o Operator subjective preference

Various configurations were tested using maximum/minimum difference readings, Hi/Lo readings, and subjective assessments using 29 subjects.

The results indicate vertical scale orientation is superior to horizontal, digital data may be either remote or adjacent to the analog representation, and either solid pointers or solid bars were preferred and statistically equal in performance. The test details are contained in the Human Engineering Summary Report.

3.3 MISSION/WORKLOAD ANALYSIS AND LITERATURE REVIEW

A review was made of existing mission profiles field manuals, task analyses, cockpit configuration studies, operational sequence diagrams, information transfer studies, man-machine interface investigations, work load assessments, etc. to the extent that this type of information was made available to General Electric. The purpose was to identify those aspects of mission type, physical environment, crew activity, etc. which impact the conceptual and hardware design of an EMMADS. The following are the general conclusions of that study:

- o Flight crews are subjected to extremely high visual/mental workloads during NOE, night, and terrain flights
- o During high workloads, visual attention to engine/drive train and related instruments constitute zero to 7% of the flight crew's total visual activity
- o To improve performance and reduce workload, system design must be optimized for high visual and mental workload but perform identically under all conditions
- o Subsystems are always essential to safety of flight and must be monitored continuously; there are no

unique mission or flight phase requirements

- o Night operations (and night vision goggles) have an impact on the requirements for display hardware

3.4 INFORMATION REQUIREMENTS ANALYSIS

The essence of the EMMADS function is to present to the pilot "what" information he requires, "when" he needs it, and "how" it is most easily interpreted. In addition, the function of EMMADS is to monitor the data for the pilot and to display information only when it is needed or requested. The automatic monitoring function thereby relieves the pilot of the instrument scanning/interpretation task when systems are operating normally.

The sensor information from the signal analysis task and the data contained in the Subsystem Status Monitor Task I Report were combined to generate pilot survey data sheets. These survey sheets were filled out by current and former pilots within General Electric. (see Figure 2 for a sample survey sheet) These results were used in the generation of preliminary format information content descriptions on a per subsystem basis. These "formats" combined the concepts of continuously displayed information, actual parameter values (in analog and digital form), status (fault) information, and message capsules. A sample is shown in Figure 3. These "formats" were for information content only; they were not intended to be final data arrangements. They were critiqued by flight crews at Ft. Campbell to determine if the information content was complete and if partitioning of data by subsystem was appropriate. In addition, the critique attempted to elicit identification of candidates for computed display parameters

SUBSYSTEM	PARAMETER/INDICATION	PRIORITY 1 TO	"WHEN" IS DISPLAY REQUIRED?				"HOW" IS INFORMATION MOST APPROPRIATELY DISPLAYED?								
			CONTIN- UOUSLY	FLY PHASE	NOT REQ'D	BY EXCEP.	UPON MANUAL REQ'US	ANALOG	DIGITAL	BOTH A & D	DISCRETE PLUS PROCEDURES	OTHER: EXPLAIN			
TRANS															
(VERT. TAPE)	OIL PRES-MAIN	2				X						X			Note 1
(CAUT. LT.)	OIL PRES-LOW MAIN	2				X						X			
(VERT. TAPE)	OIL TEMP-MAIN	2				X						X			
(CAUT. LTS.)	OIL TEMP-HIGH	2				X						X			
	MAIN, INT., TAIL														
(CAUT. LTS.)	CHIP INBIT	3				X						X			
	MDL-LR, MDL-RH														
(CAUT. LTS.)	CHIP-INT., TAIL	3				X						X			Note 2
(CAUT. LTS.)	CHIP ACCESSORY	3				X						X			
	MDL-LH, MDL-RH														
(CAUT. LTS.)	CHIP-MAIN MDL - SUPP	3				X						X			
FUEL															
(VERT. TAPE QUANTITY (1,2) TOTAL)		3				X						X			Note 3
(CAUT. LTS.)	FUEL LOW (1,2)	3				X									
(CAUT. LTS.)	FUEL PRES. LOW (1,2)	2				X							A	C	Note 4
(CAUT. LTS.)	FILTER BYP(1&2) (ADV. LIGHT) PRIME EST PHP ON	3 5				X X							C A		

Figure 2. In House Pilot Survey

ENGINE SYSTEM DISPLAY

(WITH WARNING MESSAGE CAPSULE)

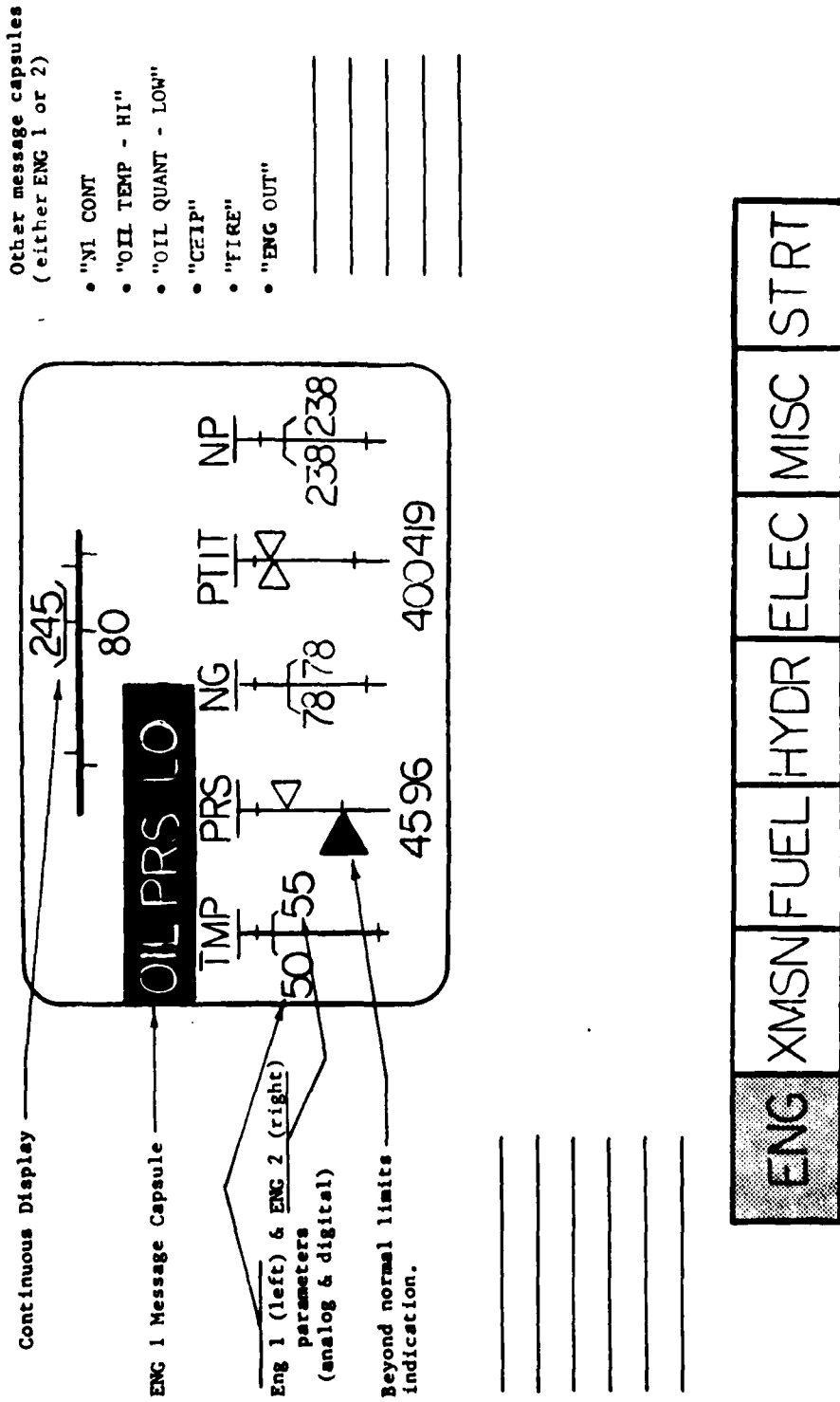

Figure 3. Engine System Display

and trend indications not presently available to the pilot and maintenance personnel.

Based on the results of these tests, candidate formats were generated. These candidate formats are consistent with a set of control/display requirements and recommendations that reflect the expected vibration, stress, and reaction times during normal cockpit activities. These recommendations, formats and general philosophy have been carried into the system design and implemented in hardware to the maximum extent practical. These formats and recommendations are contained in the Human Engineering Summary Report.

4.0 TASK III SUMMARY - DATA TRANSMISSION

4.1 SYSTEM REQUIREMENTS

The scope of this task was to examine data transmission methods for an EMMADS system. The data requirements from the signal analysis efforts were summarized along with methods of data generation and transfer on current helicopters. Current and future transmission methods were analyzed, including various types of multiplex bus standards and architecture.

EMMADS requires data from sensors that are currently diverse in type, location, reliability, and criticality. Display functions are based on raw data, while potential faults are examined based on data from various subsystems.

4.2 RECOMMENDATIONS

The various requirements indicate a medium data transfer rate from several locations on the helicopter. A centralized architecture is recommended as the most appropriate. Although the data rates required are much less than the available bandwidth, a MIL-STD-1553B bus system, integrated with other helicopter system data transfer requirements, appears to be the most practical in relation to size, cost and future potential. An optical fiber communication link can be anticipated as a future expansion of this standard. Details of this study are contained in the Data Transmission Study report.

5.0 TASK IV SUMMARY - HARDWARE

5.1 PRECONTRACT BASELINE

The General Electric contract proposal included a rather extensive description of specific hardware and a proposed system configuration. This hardware had been designed previously and was expected to be sufficiently flexible to meet the contract objectives. The hardware was designed with these characteristics:

- o MCP-701A Processor with a 580 Kop throughput and an instruction set optimized for control/display applications.
- o A dual bus MIL-STD-1553B interface that was in development at General Electric.
- o In-raster symbol generator with composite video output (per RS-170) and high speed graphics generation capability.
- o Additional I/O slots available for expansion using available or special modules.

The display unit contained a Sharp/HYCOM electroluminescent graphics display. The originally proposed separate control panel contained 10 Multi-legend display switches, each capable of displaying eight characters generated by 5 x 7 dot matrix LED's. A programmable MIL-STD-1553 bus controller/tester was originally proposed as the system exerciser.

5.2 CONTRACT EXPANSION-SYSTEM EXERCISER

Early in the program the Army determined that to adequately test and demonstrate the system a more comprehensive tester than the proposed bus exerciser would be required. The contract

was ammended in January 1980 to replace this exerciser with a Bus Controller/Simulator system. This revised system includes a General Electric MCP-701A processor containing analog and discrete interfaces, system control software, and a dual bus MIL-STD-1553B interface. A control panel with pots and switches was added to simulate the aircraft sensors and a bus monitor/controller test unit was provided.

5.3 EVOLVING HARDWARE

The results of the Human Factors Engineering and System Engineering tasks led to several changes in the hardware configuration.

5.3.1 Control Panel

The baseline hardware configuration contained a Control Panel with ten multilegend display switches. The quantity was selected as the minimum to allow data entry. Both system design and human factors efforts suggested these multilegend switches should be contained in the display unit and located in a single row below the solid-state display panel. A quantity of seven (7) was considered an optimum number, considering the subsystems to be monitored and the available space. The display was constructed in that configuration.

5.3.2 Display Unit

The feasibility model display unit was designed around a solid-state electroluminescent graphics panel manufactured by Sharp/HYCOM. The panel has a video interface per EIA-STD-RS-170. The active area is 3.5 x 4.7 inches with a resolution

of 240 x 320 dots. The display unit is shown in Figure 4. Note the multilegend display switches and the large size chassis caused by the Sharp/HYCOM display panel construction. Improved display panels are being developed under Army contracts.

5.3.3 Data Entry

Incorporating the multilegend switch into the display unit required a re-assessment of the data entry requirements for checklists, etc. Two methods were determined to be easily integrated into the hardware; a touch panel overlay to the display and a separate data entry keyboard. To allow the greatest flexibility, both were provided. The touch panel was not installed when it was determined that due to the display panel construction, possible damage could result from the pressure of "pushing" switches. Improved graphics panel mounting techniques by Sharp/HYCOM should alleviate this problem in the future. A handheld alpha/numeric keyboard manufactured by Termiflex Corporation was purchased and interfaced to the display processor. This unit has an RS-232/C serial interface and can generate and display the ASCII character set. This unit is shown in Figure 5.

5.4 DISPLAY PROCESSOR

The MCP-701A Raster Symbol Generator (RSG) is shown in Figure 6. This Display Processor is packaged in an ARINC 1-ATR shape configuration. A block diagram is shown in Figure 7. Several changes were incorporated into this unit as a result

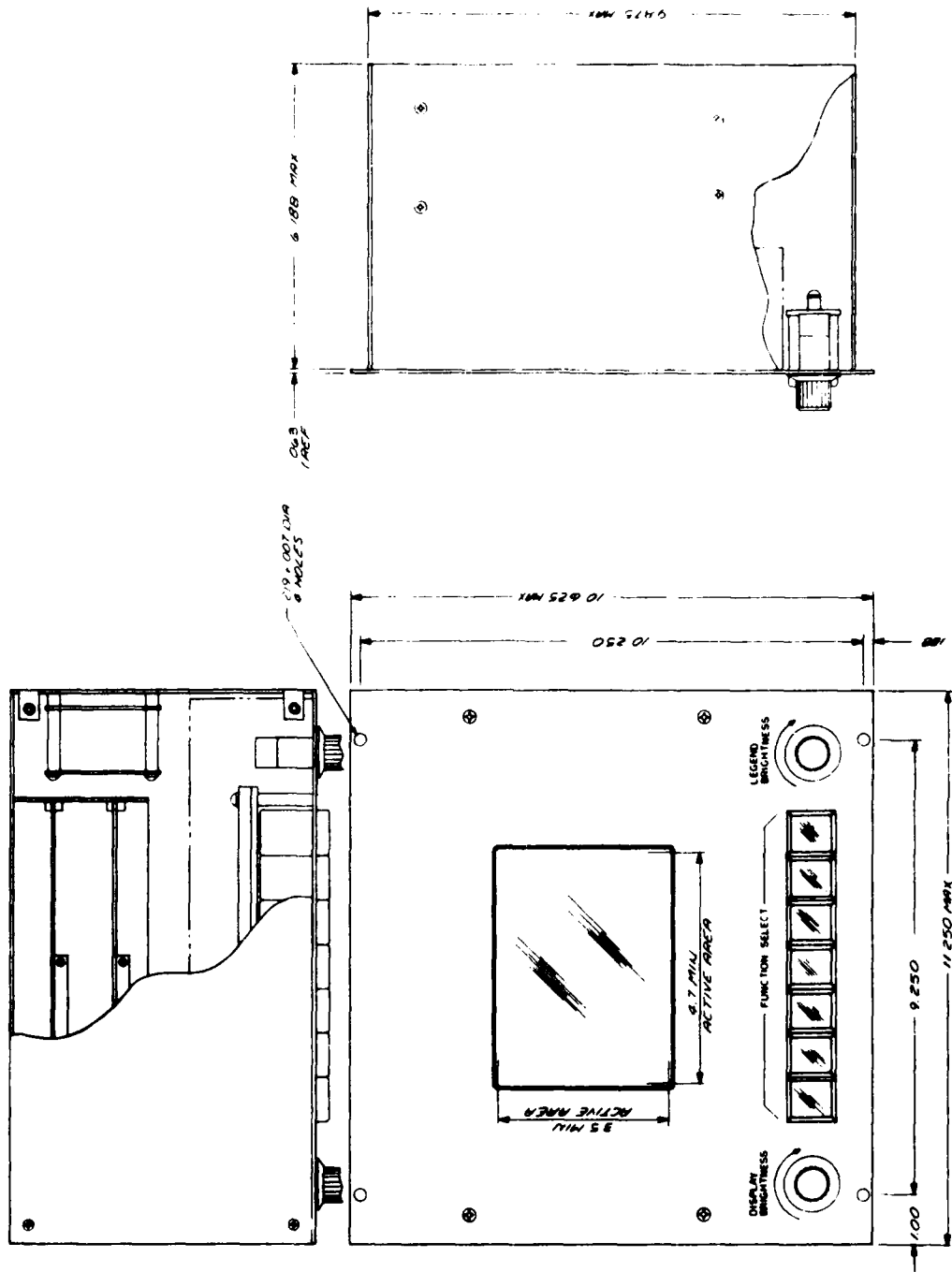

Figure 4. Feasibility Model Display Unit

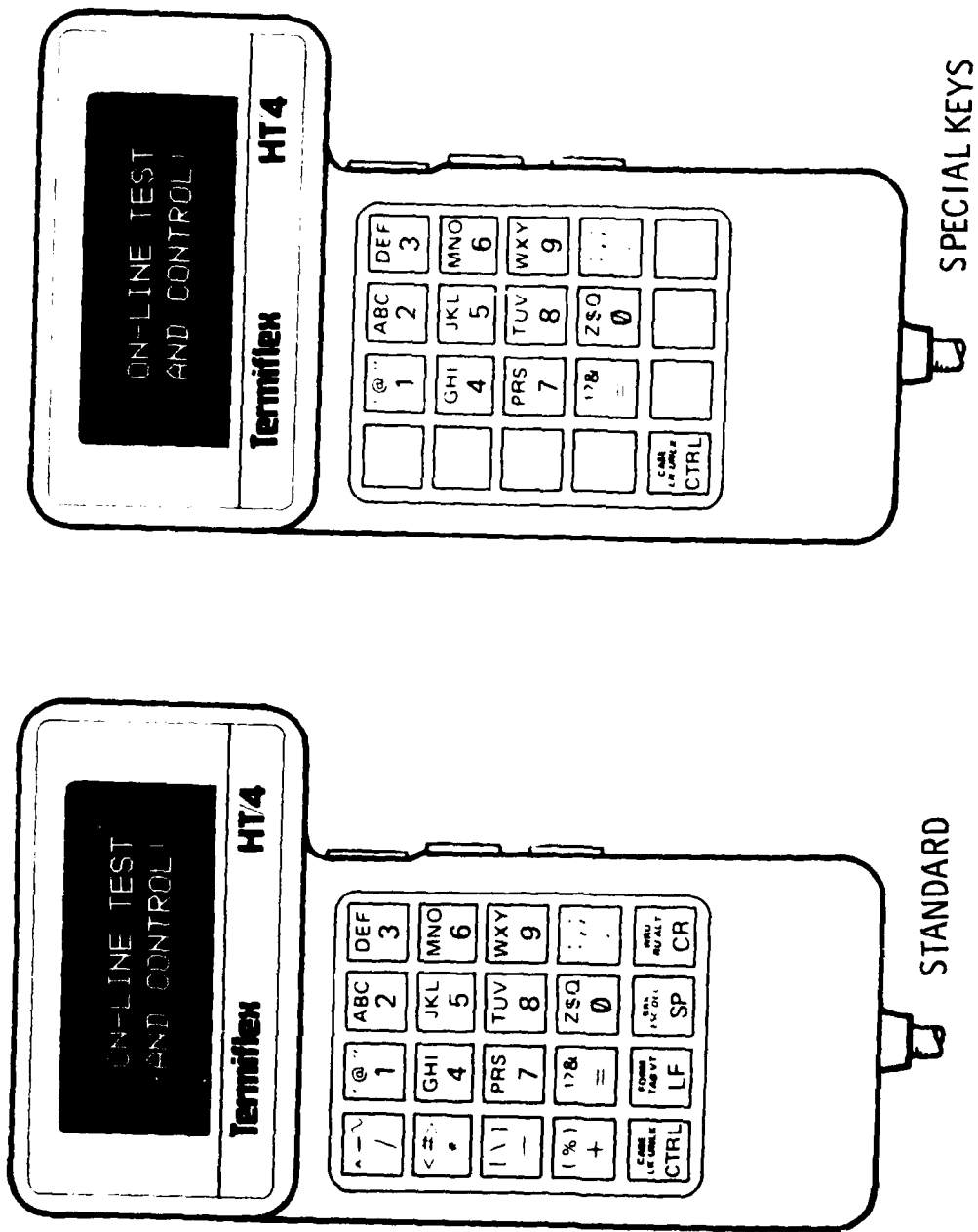

Figure 5. Termiflex Alpha/Numeric Keyboard

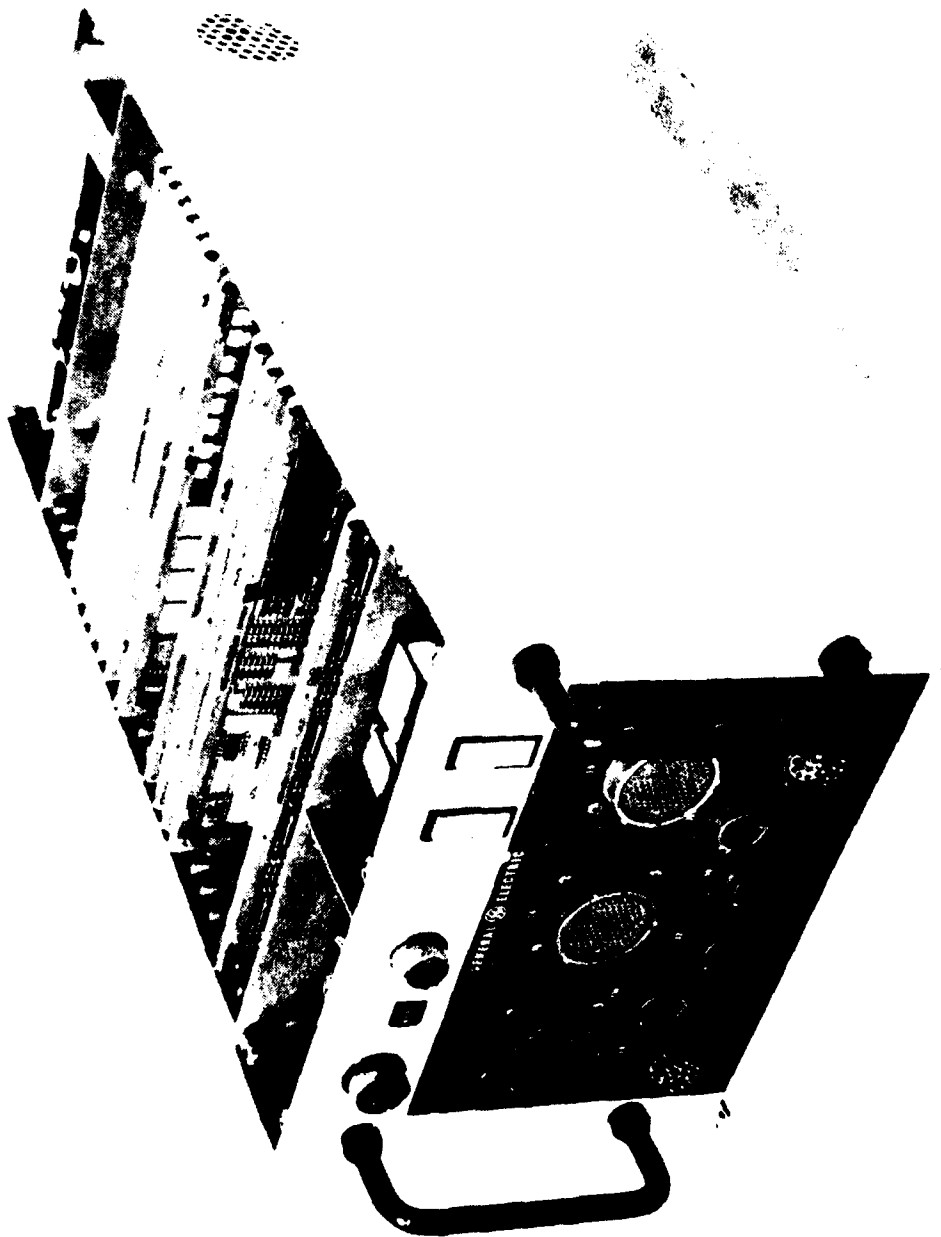

Figure 6. MCP-701A Raster Symbol Generator

of system requirements determined by Tasks I and II.

- o A second symbol generator image buffer was added to allow hardware generation of block filled symbols.
- o RS-232/C interfaces was expanded to a quad interface module for multilegend switches, keyboard, and future expansion.
- o The MIL-STD-1553B interface was modified to allow software control of Bus Controller and Remote Terminal modes.

The MCP-701A processor proved to be easily able to handle the computational requirements imposed by the system design with sufficient expansion capability to allow additional functions to be implemented in the future. The Development Specification identifies the requirements for the feasibility model. Schematics and drawing for the hardware are being supplied with the system.

5.5 OPERATIONAL SOFTWARE

The implementation of an EMMADS system for a CH-47C helicopter is covered by the Operational Functions Report. This report defines the requirements for operational modes and system reaction to input data. These functions were programmed in software in the MCP-701A processor/symbol generator. The requirements and incorporated functions are identified in the Operational Functions Report, Development Specification, and the Test and Demonstration Report. Complete operational software listings are being supplied with the system.

5.6 EMMADS SYSTEM ARCHITECTURE

The overall block diagram of an EMMADS installed on a helicopter is shown in Figure 8. A total helicopter equipment set would consist of one or more Remote Terminal Units connected to the various aircraft sensors. System reliability dictates hardware reliability, such as achieved by dual EMMADS Display Processors and redundant sensors and interfaces. These elements would most likely be interfaced through a dual redundant 1553 Bus. Other aircraft systems may of course be interfaced via the same 1553 bus using the spare bus bandwidth. Somewhere within the system, a bus controller function must be incorporated.

The EMMADS feasibility hardware implementation of this architecture is shown in Figure 9. The aircraft sensors and Remote Terminals (R/T's) are simulated by the analog/discrete interfaces and a Raster Symbol Generator (available through consignment and previous government contracts). The EMMADS Display Processor is the bus controller in this configuration.

Figures 10 and 11 show the standard CH-47C helicopter and instrument panel. Figure 12 shows the result of removing the Caution/Warning panel and engine instruments and installing two EMMADS display units in the center instrument panel.

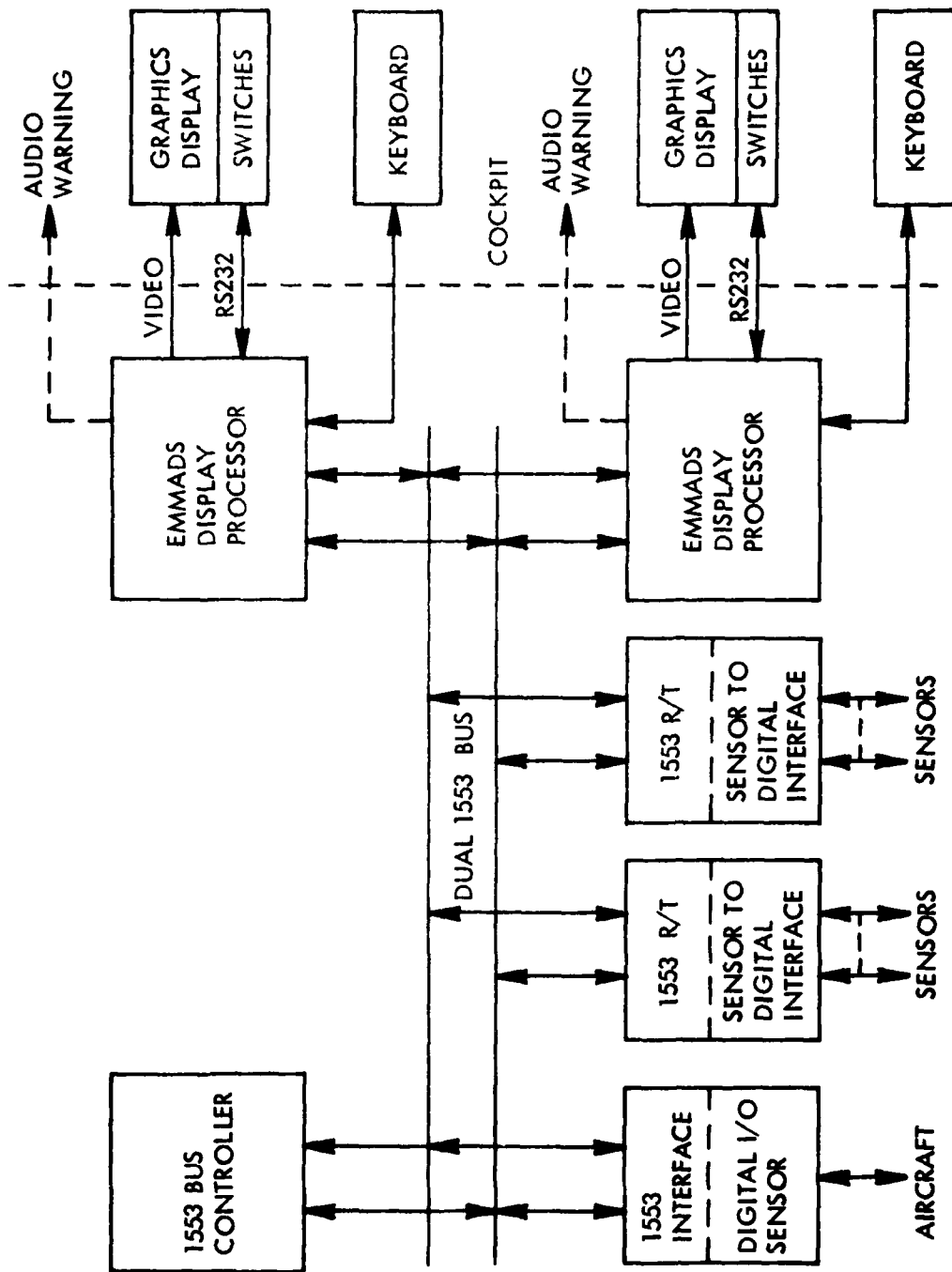

Figure 8. EMMADS Block Diagram

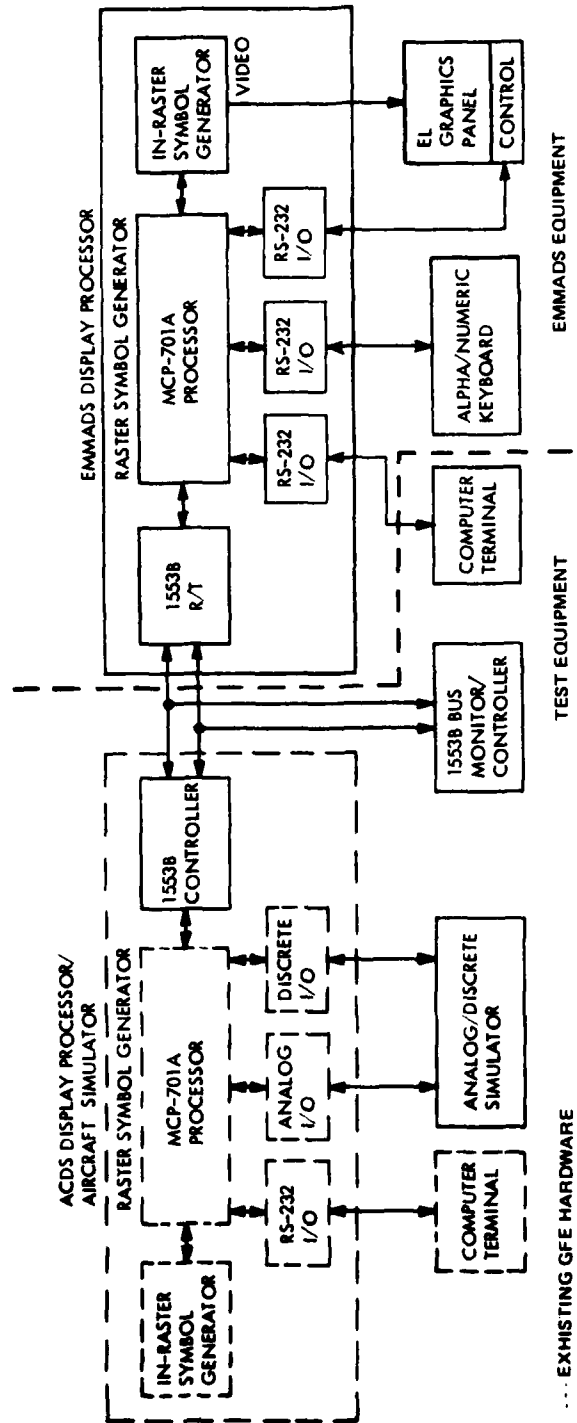

Figure 9. EMMADS Feasibility Hardware

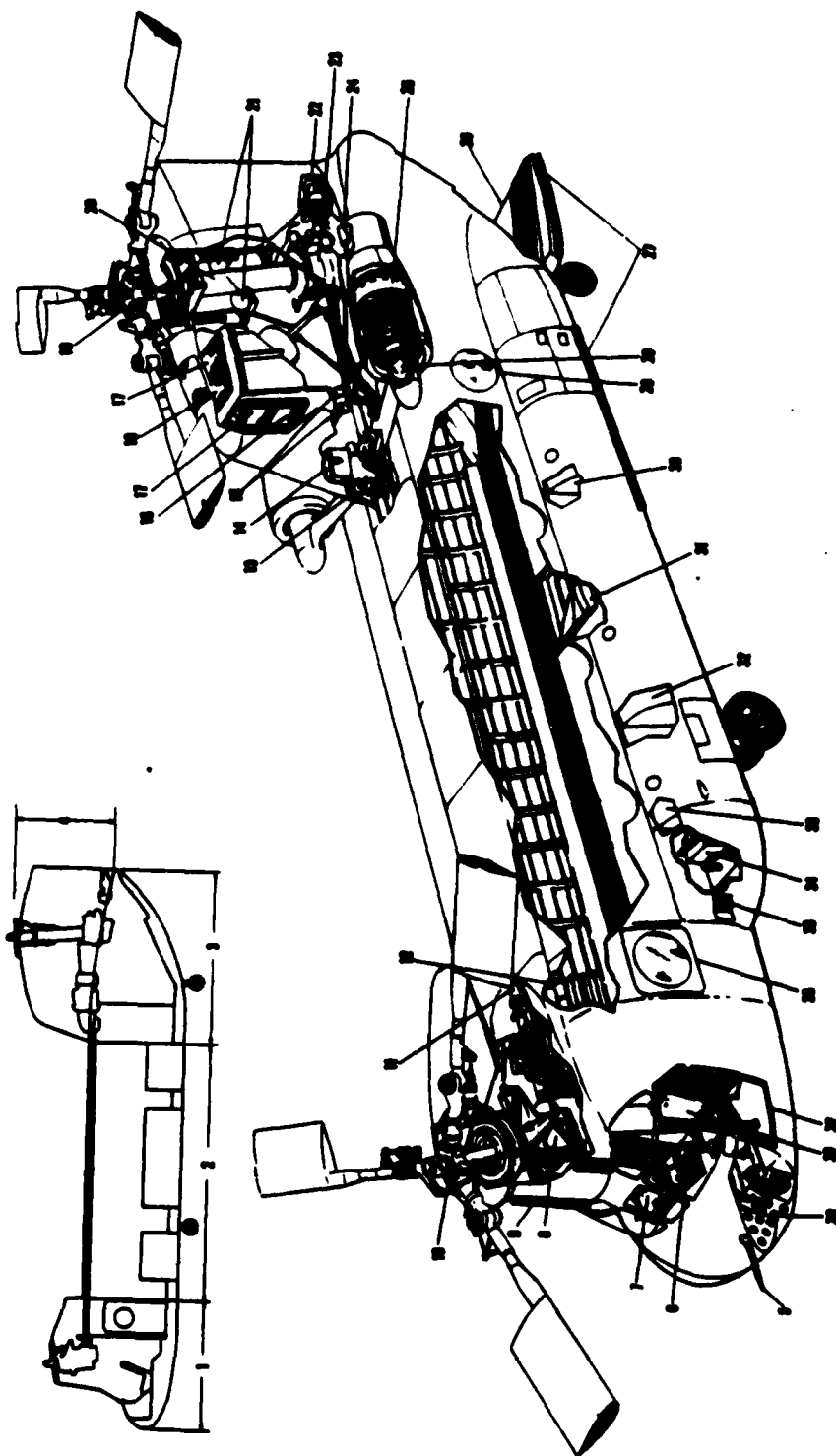

Figure 10. CH-47C Helicopter

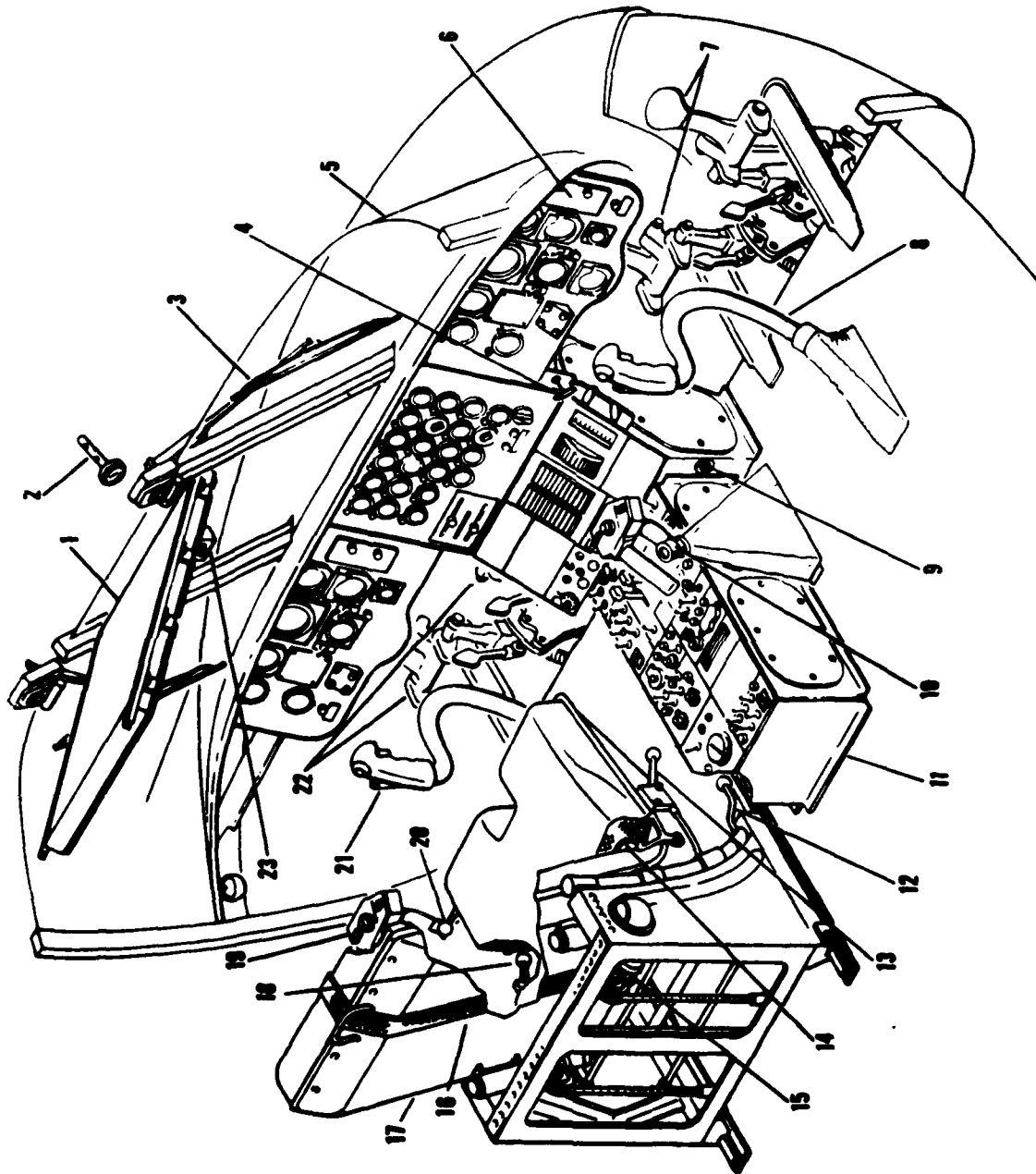

Figure 11. CH-47C Instrument Panel

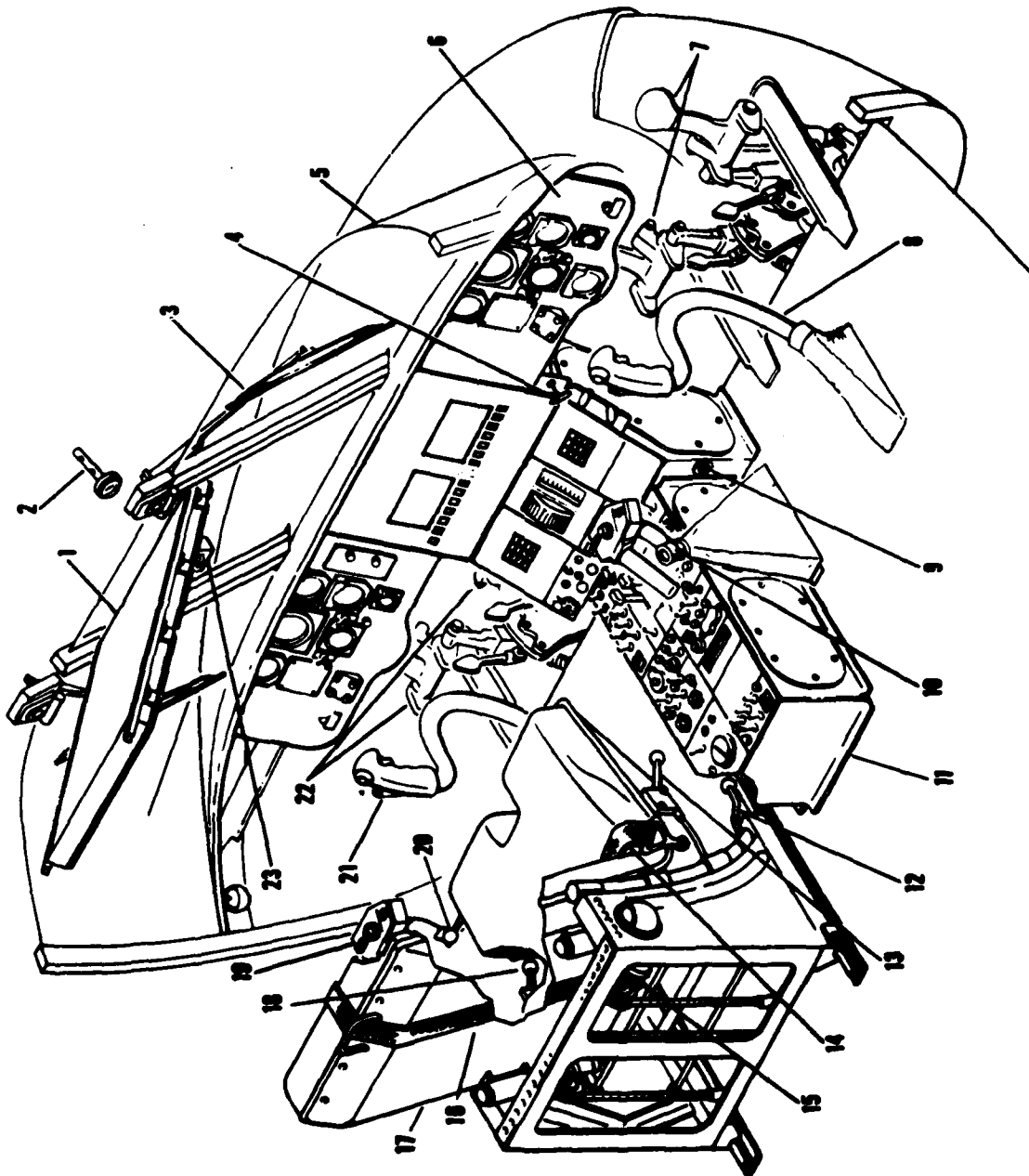

Figure 12. CH-47C With EMMADS Installed

6.0 CONTRACT COST AND SCHEDULE

6.1 CONTRACT FUNDING

The cost plus-fixed-fee contract was awarded June 28, 1979 with a total value of \$441,936. The contract was modified in January 1980 to expand the system exerciser. \$103,000 was negotiated in June 1980 to cover these efforts. In November 1970 an overrun of \$141,158 was negotiated, bringing the total contract funds to \$686,094. Several things contributed to this overrun; inflation of material costs, addition of hardware not anticipated during the proposal stages, and a more complex software effort than expected.

6.2 CONTRACT SCHEDULE

Figure 13 shows the proposed program schedule. The original contract was 18 months beginning June 28, 1979.

Hardware delivery was delayed until March, 1981, due to delays in software integration.

The Acceptance Test was performed at Ft. Monmouth on May 20, 1981. This test is documented in the Test and Demonstration Report.

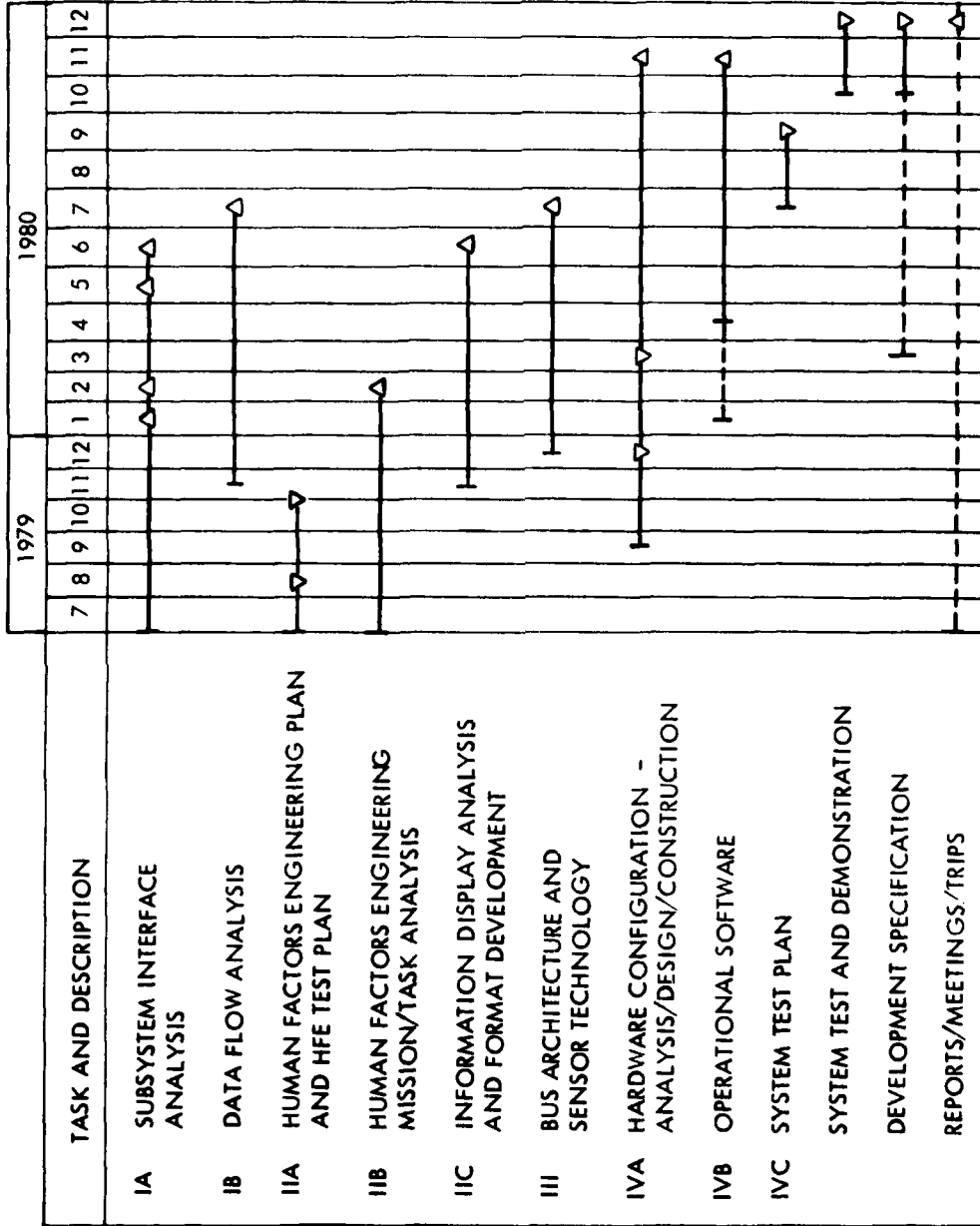

Figure 13. EMMADS Program Schedule

END

DATE
FILMED

11-81

DTIC