

AD-A105 102

ANDERSON ENGINEERING INC SPRINGFIELD MO
NATIONAL DAM SAFETY PROGRAM, STRUCTURE E-1 (MO 20511), VERDIGRI--ETC(U)
AUG 80 J HEALY, S BRADY, N MORALES, T BECKLEY DACW43-80-C-0073

F/G 13/13

UNCLASSIFIED

NL

1 of 2
AD-A
15-UC

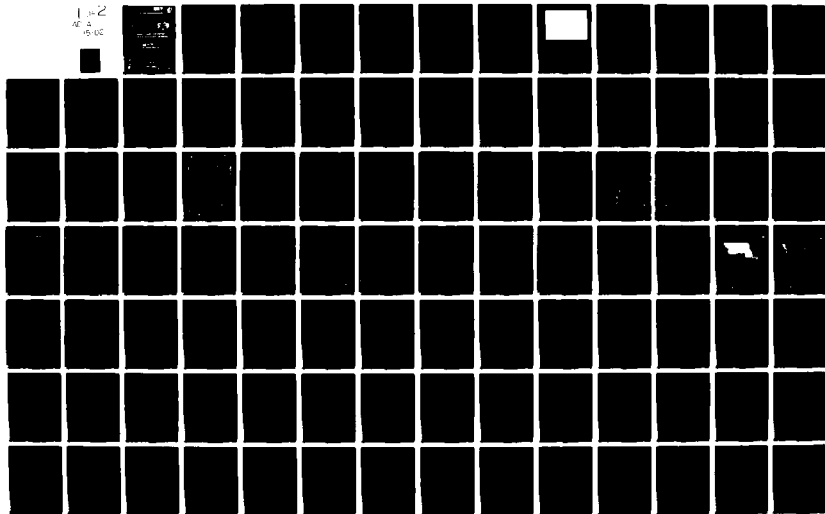

AD A105102

VERDIGRIS-NEOSHO DAM

STRUCTURE E-1

NEWTON COUNTY, MISSOURI

NO 20011

**PHASE 1 INSPECTION REPORT
NATIONAL DAM SAFETY PROGRAM**



United States Army
Corps of Engineers
... Army in Action
... Serving the Nation

St. Louis District

PREPARED BY: U.S. ARMY ENGINEER DISTRICT, ST. LOUIS

FOR: STATE OF MISSOURI

FILE COPY

AUGUST, 1960

This document has been approved
for public release and sale
distribution is unlimited.

A1 10

UNCLASSIFIED

SECURITY CLASSIFICATION OF THIS PAGE (When Data Entered)

REPORT DOCUMENTATION PAGE		READ INSTRUCTIONS BEFORE COMPLETING FORM
1. REPORT NUMBER	2. GOVT ACCESSION NO. AD-A105102	3. RECIPIENT'S CATALOG NUMBER
4. TITLE (and Subtitle) Phase I Dam Inspection Report National Dam Safety Program Newton County Structure E-1 (MO 20511) Newton County, Missouri		5. TYPE OF REPORT & PERIOD COVERED Final Report
		6. PERFORMING ORG. REPORT NUMBER
7. AUTHOR(s) Anderson Engineering, Inc. Jack /Healy/ Steve /Brady/ Nelson /Morales Tom /Beckley		8. CONTRACT OR GRANT NUMBER(s) DACW43-80-C-0073
9. PERFORMING ORGANIZATION NAME(S) AND ADDRESS(ES) U.S. Army Engineer District, St. Louis Dam Inventory and Inspection Section, LMSED-PD 210 Tucker Blvd., North, St. Louis, Mo. 63101		10. PROGRAM ELEMENT, PROJECT, TASK AREA & WORK UNIT NUMBERS 11-11-1
11. CONTROLLING OFFICE NAME AND ADDRESS U.S. Army Engineer District, St. Louis Dam Inventory and Inspection Section, LMSED-PD 210 Tucker Blvd., North, St. Louis, Mo. 63101		12. REPORT DATE August 1980
		13. NUMBER OF PAGES Approximately 95
14. MONITORING AGENCY NAME & ADDRESS (if different from Controlling Office) National Dam Safety Program. Structure E-1 (MO 20511), Verdigris - Neosho River Basin, Newton County, Missouri. Phase I Inspection Report.		15. SECURITY CLASS. (of this report) UNCLASSIFIED
16. DISTRIBUTION STATEMENT (of this Report) Approved for release; distribution unlimited.		
17. DISTRIBUTION STATEMENT (of the abstract entered in Block 20, if different from Report)		
18. SUPPLEMENTARY NOTES		
19. KEY WORDS (Continue on reverse side if necessary and identify by block number) Dam Safety, Lake, Dam Inspection, Private Dams		
20. ABSTRACT (Continue on reverse side if necessary and identify by block number) This report was prepared under the National Program of Inspection of Non-Federal Dams. This report assesses the general condition of the dam with respect to safety, based on available data and on visual inspection, to determine if the dam poses hazards to human life or property.		

DD FORM 1 JAN 73 1473

EDITION OF 1 NOV 65 IS OBSOLETE

UNCLASSIFIED

SECURITY CLASSIFICATION OF THIS PAGE (When Data Entered)

INSTRUCTIONS FOR PREPARATION OF REPORT DOCUMENTATION PAGE

RESPONSIBILITY. The controlling DoD office will be responsible for completion of the Report Documentation Page, DD Form 1473, in all technical reports prepared by or for DoD organizations.

CLASSIFICATION. Since this Report Documentation Page, DD Form 1473, is used in preparing announcements, bibliographies, and data banks, it should be unclassified if possible. If a classification is required, identify the classified items on the page by the appropriate symbol.

COMPLETION GUIDE

General. Make Blocks 1, 4, 5, 6, 7, 11, 13, 15, and 16 agree with the corresponding information on the report cover. Leave Blocks 2 and 3 blank.

Block 1. Report Number. Enter the unique alphanumeric report number shown on the cover.

Block 2. Government Accession No. Leave Blank. This space is for use by the Defense Documentation Center.

Block 3. Recipient's Catalog Number. Leave blank. This space is for the use of the report recipient to assist in future retrieval of the document.

Block 4. Title and Subtitle. Enter the title in all capital letters exactly as it appears on the publication. Titles should be unclassified whenever possible. Write out the English equivalent for Greek letters and mathematical symbols in the title (see "Abstracting Scientific and Technical Reports of Defense-sponsored RDT/E," AD-667 000). If the report has a subtitle, this subtitle should follow the main title, be separated by a comma or semicolon if appropriate, and be initially capitalized. If a publication has a title in a foreign language, translate the title into English and follow the English translation with the title in the original language. Make every effort to simplify the title before publication.

Block 5. Type of Report and Period Covered. Indicate here whether report is interim, final, etc., and, if applicable, inclusive dates of period covered, such as the life of a contract covered in a final contractor report.

Block 6. Performing Organization Report Number. Only numbers other than the official report number shown in Block 1, such as series numbers for in-house reports or a contractor/grantee number assigned by him, will be placed in this space. If no such numbers are used, leave this space blank.

Block 7. Author(s). Include corresponding information from the report cover. Give the name(s) of the author(s) in conventional order (for example, John R. Doe or, if author prefers, J. Robert Doe). In addition, list the affiliation of an author if it differs from that of the performing organization.

Block 8. Contract or Grant Number(s). For a contractor or grantee report, enter the complete contract or grant number(s) under which the work reported was accomplished. Leave blank in in-house reports.

Block 9. Performing Organization Name and Address. For in-house reports enter the name and address, including office symbol, of the performing activity. For contractor or grantee reports enter the name and address of the contractor or grantee who prepared the report and identify the appropriate corporate division, school, laboratory, etc., of the author. List city, state, and ZIP Code.

Block 10. Program Element, Project, Task Area, and Work Unit Numbers. Enter here the number code from the applicable Department of Defense form, such as the DD Form 1498, "Research and Technology Work Unit Summary" or the DD Form 1634, "Research and Development Planning Summary," which identifies the program element, project, task area, and work unit or equivalent under which the work was authorized.

Block 11. Controlling Office Name and Address. Enter the full, official name and address, including office symbol, of the controlling office. (Equates to funding/sponsoring agency. For definition see DoD Directive 5200.20, "Distribution Statements on Technical Documents.")

Block 12. Report Date. Enter here the day, month, and year or month and year as shown on the cover.

Block 13. Number of Pages. Enter the total number of pages.

Block 14. Monitoring Agency Name and Address (if different from Controlling Office). For use when the controlling or funding office does not directly administer a project, contract, or grant, but delegates the administrative responsibility to another organization.

Blocks 15 & 15a. Security Classification of the Report: Declassification/Downgrading Schedule of the Report. Enter in 15 the highest classification of the report. If appropriate, enter in 15a the declassification/downgrading schedule of the report, using the abbreviations for declassification/downgrading schedules listed in paragraph 4-207 of DoD 5200.1-R.

Block 16. Distribution Statement of the Report. Insert here the applicable distribution statement of the report from DoD Directive 5200.20, "Distribution Statements on Technical Documents."

Block 17. Distribution Statement (of the abstract entered in Block 20, if different from the distribution statement of the report). Insert here the applicable distribution statement of the abstract from DoD Directive 5200.20, "Distribution Statements on Technical Documents."

Block 18. Supplementary Notes. Enter information not included elsewhere but useful, such as: Prepared in cooperation with . . . Translation of (or by) . . . Presented at conference of . . . To be published in . . .

Block 19. Key Words. Select terms or short phrases that identify the principal subjects covered in the report, and are sufficiently specific and precise to be used as index entries for cataloging, conforming to standard terminology. The DoD "Thesaurus of Engineering and Scientific Terms" (TEST), AD-672 000, can be helpful.

Block 20. Abstract. The abstract should be a brief (not to exceed 200 words) factual summary of the most significant information contained in the report. If possible, the abstract of a classified report should be unclassified and the abstract to an unclassified report should consist of publicly-releasable information. If the report contains a significant bibliography or literature survey, mention it here. For information on preparing abstracts see "Abstracting Scientific and Technical Reports of Defense-Sponsored RDT&E," AD-667 000.



REPLY TO
ATTENTION OF

DEPARTMENT OF THE ARMY
ST. LOUIS DISTRICT, CORPS OF ENGINEERS
210 TUCKER BOULEVARD, NORTH
ST. LOUIS, MISSOURI 63101

SUBJECT: Structure E-1
Newton County, Missouri
Missouri Inventory No. 20511

This report presents the results of field inspection and evaluation of the Structure E-1. It was prepared under the National Program of Inspection of Non-Federal Dams.

SIGNED

SUBMITTED BY: _____
Chief, Engineering Division

17 SEP 1980

Date

APPROVED BY: _____
Colonel, CE, **SIGNED** Engineer

10 SEP 1980

Date

Accession For	
NTIS GRA&I	<input checked="" type="checkbox"/>
DTIC TAB	<input type="checkbox"/>
Unannounced	<input type="checkbox"/>
Justification	
By _____	
Distribution/	
Availability Codes	
Dist	Avail and/or Special
A	

VERDIGRIS-NEOSHO RIVER BASIN

STRUCTURE E-1
NEWTON COUNTY, MISSOURI
MISSOURI INVENTORY NO. 20511

PHASE I INSPECTION REPORT
NATIONAL DAM SAFETY PROGRAM

Prepared By

Anderson Engineering, Inc., Springfield, Missouri
Hanson Engineers, Inc., Springfield, Illinois

Under Direction Of

St. Louis District, Corps of Engineers

For

Governor of Missouri

AUGUST, 1980

PHASE I REPORT
NATIONAL DAM SAFETY PROGRAM
SUMMARY

Name of Dam: Structure E-1
State Located: Missouri
County Located: Newton
Stream: Tributary of Lost Creek
Date of Inspection: May 28, 1980

Structure E-1 was inspected by an interdisciplinary team of engineers from Anderson Engineering, Inc. of Springfield, Missouri and Hanson Engineers, Inc. of Springfield, Illinois. The purpose of this inspection was to make an assessment of the general condition of the dam with respect to safety, based upon available data and visual inspection, in order to determine if the dam poses hazards to human life or property.

The guidelines used in the assessment were furnished by the Department of the Army, Office of the Chief of Engineers, and they have been developed with the help of several Federal and State agencies, professional engineering organizations, and private engineers. Based on these guidelines, the St. Louis District, Corps of Engineers has determined that this dam is in the high hazard potential classification, which means that loss of life and appreciable property loss could occur if the dam fails. The estimated damage zone extends approximately 2 miles downstream of the dam. Located within this zone are approximately 6 dwellings, 6 buildings and a railroad.

The dam is in the intermediate size classification, since it is greater than 40 ft high but less than 100 ft high. The maximum storage capacity is greater than 50 ac-ft but less than 1000 ac-ft.

Our inspection and evaluation indicate that the combined spillways do not meet the criteria set forth in the guidelines for a dam having the above size and hazard potential. The combined spillways will pass 70 percent of the Probable Maximum Flood without overtopping. The Probable Maximum Flood is defined as the flood discharge that may be expected from the most severe combination of critical meteorologic and hydrologic conditions that are reasonably possible in the region. The guidelines require that a dam of intermediate size with a high downstream hazard potential pass the PMF.

The PMF has been determined to be the appropriate spillway design flood. The 1 percent probability flood will not overtop the dam. The 1 percent probability flood is one that has a 1 percent chance of being exceeded in any given year.

Deficiencies visually observed by the inspection team were: (1) Standing water on the downstream berm; (2) standing water at the downstream toe of embankment; and (3) some erosion on the embankment slopes.

Another deficiency was the lack of seepage and stability analysis comparable to the requirements of the recommended guidelines.

It is recommended that the owners take the necessary action without undue delay to correct the deficiencies reported herein. A detailed discussion of these deficiencies is included in the following report.

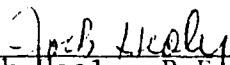

Jack Healy, P.E.
Hanson Engineers, Inc.

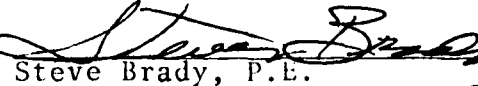

Steve Brady, P.E.
Anderson Engineering, Inc.

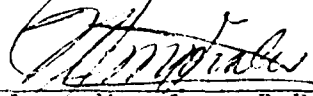

Nelson Morales, P.E.
Hanson Engineers, Inc.



Tom Beckley, P.E.
Anderson Engineering, Inc.



AERIAL VIEW OF LAKE AND DAM

PHASE 1 INSPECTION REPORT
NATIONAL DAM SAFETY PROGRAM
STRUCTURE E-1 ID NO. 20511

TABLE OF CONTENTS

<u>Paragraph No.</u>	<u>Title</u>	<u>Page No.</u>
	SECTION 1 - PROJECT INFORMATION	
1.1	General	1
1.2	Description of the Project	1
1.3	Pertinent Data	3
	SECTION 2 - ENGINEERING DATA	
2.1	Design	7
2.2	Construction	8
2.3	Operation	8
2.4	Evaluation	9
	SECTION 3 - VISUAL INSPECTION	
3.1	Findings	10
3.2	Evaluation	11
	SECTION 4 - OPERATIONAL PROCEDURES	
4.1	Procedures	12
4.2	Maintenance of Dam	12
4.3	Maintenance of Operating Facilities	12
4.4	Description of Any Warning System in Effect	12
4.5	Evaluation	12
	SECTION 5 - HYDRAULIC/HYDROLOGIC	
5.1	Evaluation of Features	13
	SECTION 6 - STRUCTURAL STABILITY	
6.1	Evaluation of Structural Stability	15
	SECTION 7 - ASSESSMENT/REMEDIAL MEASURES	
7.1	Dam Assessment	16
7.2	Remedial Measures	17

APPENDICES

	<u>Sheet</u>
APPENDIX A	
Location Map	1
Vicinity Map	2
Plan, Profile and Section of Dam	3
Spillway Section and Profile	3A
Plan Sketch of Dam	4
Project Map - Lost Creek Watershed	5
SCS As Built Plan Sheets	6 - 11
Inspection Report	12
APPENDIX B	
Geologic Regions of Missouri	1
Thickness of Loessial Deposits	2
Geologic Investigation Plan Sheet	3
Detailed Geologic Investigation of Dam Site	4 - 41
Geologic Report	42
APPENDIX C	
Overtopping Analysis - PMF	1 - 9
APPENDIX D	
List of Photographs	1
Photograph Index	2
Photographs	

SECTION 1 - PROJECT INFORMATION

1.1 GENERAL:

A. Authority:

The National Dam Inspection Act, Public Law 92-367, authorized the Secretary of the Army, through the Corps of Engineers, to initiate a program of safety inspection of dams throughout the United States. Pursuant to the above, the St. Louis District, Corps of Engineers, District Engineer directed that a safety inspection be made of Structure E-1 in Newton County, Missouri.

B. Purpose of Inspection:

The purpose of the inspection was to make an assessment of the general condition of the dam with respect to safety, based upon available data and a visual inspection in order to determine if the dam poses hazards to human life or property.

C. Evaluation Criteria:

Criteria used to evaluate the dam were furnished by the Department of the Army, Office of the Chief of Engineers, "Recommended Guidelines for Safety Inspection of Dams, Appendix D." These guidelines were developed with the help of several federal agencies and many state agencies, professional engineering organizations, and private engineers.

1.2 DESCRIPTION OF PROJECT:

A. Description of Dam and Appurtenances:

Structure E-1 is an earth fill structure approximately 45 ft high and 735 ft long at the crest. The appurtenant work consists of a 30 inch diameter reinforced concrete primary spillway pipe with a reinforced concrete flow riser and an earth cut swale located at the west abutment.

Sheet 3 of Appendix A shows a plan, profile and typical section of the embankment as obtained from field inspection data. Sheets 6 through 11 of Appendix A are selected As Built drawings obtained from the U. S. Department of Agriculture, Soil Conservation Service, Columbia, Missouri.

B. Location:

The dam is located in the west-central part of Newton County, Missouri on a tributary of Lost Creek. The dam and lake are within the Racine, Missouri 7.5 minute quadrangle sheet (Section 16, T25N, R33W - latitude 36°53.5', longitude 94°32.4'). Sheet 2 of Appendix A shows the general vicinity. Sheet 5 of Appendix A is the Project Map developed as part of the Work Plan for Watershed Protection and Flood Prevention for the Lost Creek Watershed prepared by the Soil and Water Conservation District of Newton County.

C. Size Classification:

With an embankment height of 45 ft and a maximum storage capacity of approximately 700 acre-ft, the dam is in the intermediate size category.

D. Hazard Classification:

The St. Louis District, Corps of Engineers has classified this dam as a high hazard dam. The estimated damage zone extends approximately 2 miles downstream of the dam. Located within this zone are approximately 6 dwellings, 6 buildings and a railroad. The location of most of the above were verified by the inspection team.

E. Ownership:

The dam is owned by the Lost Creek Watershed Subdistrict, Jim Stone, Chairman, P. O. Box 149, Neosho, Missouri 64850; and is on property owned by Mr. Gus Buzzard, Route 2, Neosho, Missouri 64850.

F. Purpose of Dam:

The dam was constructed under the Authority of the Watershed Protection and Flood Prevention Act (Public Law 566, 83rd Congress, 68 Statute 666) as amended primarily for the purpose of a Floodwater Retarding Structure for the Lost Creek Watershed, Newton County, Missouri.

G. Design and Construction History:

The dam was designed by the U. S. Department of Agriculture, Soil Conservation Service, Columbia, Missouri, under the Authority of the Watershed Protection and Flood Prevention Act. Prior to the design of the dams, a watershed work plan for the Lost Creek Watershed was prepared in January, 1971, by the Soil and Water Conservation District of Newton County with assistance by SCS. A partial set of As Built Plans are included as Sheets 6 through 10 of Appendix A. A complete set of plans are available through the Columbia, Missouri office of SCS.

Geologic Investigation and analysis completed by SCS are included as Sheets 3 through 42 of Appendix B. A Geologic Report prepared by the State of Missouri Geology and Land Survey Section is included as Sheet 43.

The contract for construction was let on July 22, 1977, for Newton County Structure E-1.

Inspection of the project was conducted under the control of Mr. Joe Green, Project Engineer, Soil Conservation Service, Mount Vernon, Missouri. Results of the inspection and testing including inspector's field notes, compaction and concrete reports, are currently on file in the Columbia, Missouri SCS office.

The contractor for the project was Don Stewart Construction Company, Joplin, Missouri. Construction commenced in October, 1977, and the dam was completed in August, 1979.

Mr. Buzzard, a retired contractor, observed the daily progress of the construction. He stated that the dam was built in general conformance with the plans with the exception of the modification of the internal drainage system near Spring #2 (See Sheet 9 of Appendix A). An additional drainage system through the embankment was deemed necessary after the core trench was excavated and Spring #2 area was cleaned out. Mr. Buzzard indicated that the numerous springs in the embankment area drain to the toe area and the resulting flow moves to the downstream channel near the toe. He stated that one spring, previously used for watering purposes, has not cleared up since construction of the dam.

During construction of the dam, a channel approximately 100 ft in width at the east abutment was constructed to carry the flow. As the dam neared completion, the flow was diverted to the inlet structure and fill material compacted in the previously used channel.

Mr. Buzzard indicated that the downstream berm was extended in length to the west due to the excess rock removed during construction. He stated that 102 days after the spillway slide gate was closed, water flowed through the upper orifice into the spillway pipe.

II. Normal Operating Procedures:

All flows will normally be passed by the restricted flow riser to the 30 inch spillway pipe and the uncontrolled earth cut emergency spillway. Information obtained from Mr. Green and Mr. Buzzard indicates that the maximum pool level for this dam was approximately 6 inches above the upper orifice inlet. The emergency spillway has never been used.

1.3 PERTINENT DATA:

Pertinent data about the dam, appurtenant works, and reservoir are presented in the following paragraphs. Sheet 3 of Appendix A presents a plan, profile and typical section of the embankment from field data obtained by the inspection team. Sheets 6 through 11 of Appendix A are selected sheets from the complete set of As Built plans prepared by the Soil Conservation Service.

A. Drainage Area:

The drainage area for this dam, as obtained from the Watershed Work Plan and As Built Plans (Sheet 11 of Appendix A) is approximately 736 acres.

B. Discharge at Dam Site:

- (1) All discharge at the dam site is through the restricted flow riser for the 30 inch diameter principal spillway pipe and an uncontrolled earth cut emergency spillway.
- (2) Estimated Total Spillway Capacity at Maximum Pool (Top of Dam - El. 1002.9): 4918 cfs
- (3) Estimated Capacity of Principal Spillway: 68 cfs
- (4) Estimated Capacity of Emergency Spillway: 4850 cfs
- (5) Estimated Experienced Maximum Flood at Dam Site: Unknown
- (6) Diversion Tunnel Low Pool Outlet at Pool Elevation: Not Applicable
- (7) Diversion Tunnel Outlet at Pool Elevation: Not Applicable
- (8) Gated Spillway Capacity at Pool Elevation: Not Applicable
- (9) Gated Spillway Capacity at Maximum Pool Elevation: Not Applicable

C. Elevations:

All elevations are consistent with an assumed mean sea level elevation of 1005.3 for B.M. #1, described in As Built Plans as concrete monument 50 ft left of Sta. 0 + 00 centerline of dam. (See Sheet 6 of Appendix A).

- (1) Top of Dam: 1002.9 (low point), 1004.8 (high point)
- (2) Principal Spillway Crest: 975.6 feet MSL
- (3) Emergency Spillway Crest: 996.4 feet MSL
- (4) Principal Spillway Pipe Invert Elevation at Outlet: 959.5 feet MSL
- (5) Streambed at Centerline of Dam: 960.0 feet MSL
- (6) Pool on Date of Inspection: 975.7 feet MSL
- (7) Apparent High Water Mark: 976.2 feet MSL
- (8) Maximum Tailwater: None
- (9) Upstream Portal Invert Diversion Tunnel: Not Applicable
- (10) Downstream Portal Invert Diversion Tunnel: Not Applicable

D. Reservoir Lengths:

- (1) At Top of Dam: 3000 Feet
- (2) At Principal Spillway Crest: 900 Feet
- (3) At Emergency Spillway Crest: 2500 Feet

E. Storage Capacities:

- (1) At Principal Spillway Crest: 60 Acre-Feet
- (2) At Top of Dam: 700 Acre-Feet
- (3) At Emergency Spillway Crest: 465 Acre-Feet

F. Reservoir Surface Areas:

- (1) At Principal Spillway Crest: 9.5 Acres
- (2) At Top of Dam: 41.5 Acres
- (3) At Emergency Spillway Crest: 31.5 Acres

G. Dam:

- (1) Type: Earth
- (2) Length at Crest: 735 Feet
- (3) Height: 45 Feet
- (4) Top Width: 14 Feet
- (5) Side Slopes: Upstream 1V:3.0H; Downstream varies from 1V:3.0H to 1V:2.5H
- (6) Zoning: Gravelly Silt and Clay
- (7) Impervious Core. 12 Feet Wide
- (8) Cutoff: 8 Feet Below Base of Dam
- (9) Grout Curtain: None

H. Diversion and Regulating Tunnel:

- (1) Type: Not Applicable
- (2) Length: Not Applicable
- (3) Closure: Not Applicable
- (4) Access: Not Applicable
- (5) Regulating Facilities: Not Applicable

I. Spillway:

I.1 Principal Spillway:

- (1) Location: Centerline Dam Station 1 + 90
- (2) Type: 30 Inch Diameter Reinforced Concrete Pipe with Restricted Flow Riser

I.2 Emergency Spillway:

- (1) Location: West Abutment
- (2) Type: Earth Cut Swale, 100 ft wide with 1V:3H side slopes
- (3) Upstream Channel: Grass covered earth channel
- (4) Downstream Channel: Grass covered channel with moderate slope

J. Regulating Outlets:

The 12 inch diameter slide gate associated with the restricted flow riser is the only regulating outlet feature of the dam.

SECTION 2 - ENGINEERING DATA

2.1 DESIGN:

Design calculations and construction plans were prepared by and are currently on file with the U. S. Department of Agriculture Soil Conservation Service in Columbia, Missouri. A partial set of these plans are included as Sheets 6 through 11 of Appendix A. A Watershed Work Plan was prepared for the Lost Creek Watershed prior to the design phase. A copy of the Project Map is included as Sheet 5 of Appendix A. This plan, prepared under the Authority of Public Law 566, is also on file in the Columbia SCS office.

A. Surveys:

A topographic survey was conducted by the Soil Conservation Service for the Lost Creek watershed. The survey was tied to the sea level datum, and temporary benchmarks were located at each dam site. Concrete monuments were set at each end of the embankment by SCS. A description of these benchmarks is shown on Sheet 6 of Appendix A. From the topographic survey data a 4 foot contour interval map was drawn for design purposes.

B. Geology and Subsurface Materials:

The site is located in the border zone between the Ozarks and Western Plains geologic regions of Missouri. This area is characterized topographically by rolling to hilly with oak and hickory forest areas. The sedimentary rock layers exposed in the Ozarks region dip downward away from the Ozarks region and the higher and younger sedimentary deposits become the surface ledges in southwest Missouri. The soils in this region are residual from cherty and dolomitic limestones of the Mississippian age. The site is located upon an outcrop of the Warsaw formation of the Meramecian series. The limestone bedrock occurs at an average depth of 10 feet below initial ground level along the entire dam centerline, as described in the Geologic Report on the site. The Geologic Report prepared by the Soil Conservation Service is contained in Appendix B.

Soils in the area of the dam are one of this area's most common soils. The embankment soils are reddish-brown silty clays (CL) with chert rock fragments. The chert is from the parent material and is found in each of the soil layers of this soil series. These soils generally make good fill material when properly compacted.

The "Geologic Map of Missouri" indicates that two known faults run in a northeast-southwesterly direction through or very near the dam site. The Missouri Geological Survey has indicated that these faults are known as the Seneca faults and there is no known activity or movement. These faults in this area are generally considered to be inactive. The publication "Caves of Missouri" indicates there are four caves in Newton County and these are several miles from the dam site.

C. Foundation and Embankment Design:

Included as Sheet 3 of Appendix B is the Geologic Investigation of Dam Site for this structure. The profile at the centerline of the dam shows the location of the borings as obtained by SCS. Sheets 4 through 42 of Appendix B are the detailed soil investigation with conclusions from the study.

Based upon the available information, the basic foundation soil appears to be silty clays (CL). There is apparently no particular zoning of the embankment. Sheet 9 of Appendix A is the As Built drainage system for this structure. The drainage system in the area of Spring #2 was modified in the field according to Mr. Green. Modification #2 was the installation of an intermediate drain outlet through the embankment.

During construction of the dam, the Soil Conservation Service added to the contract the placement of three piezometers. The location of these piezometers are as shown on Sheet 3 of Appendix A. They are usually checked weekly and after each storm. The record of the piezometer readings are maintained in the Columbia, Missouri, Soil Conservation Service Office.

D. Hydrology and Hydraulics:

The hydrologic and hydraulic design parameters of this dam are as shown on Sheet 11 of Appendix A. The Soil Conservation Service surveyed 17 valley cross-sections in the watershed and routed 8 evaluation storms through the channel using the T. R. 20 computer program. Assistance was obtained from the Tulsa District, Corps of Engineers for the study and evaluation. Based on the As Built Plans and a field check of spillway dimensions and embankment evaluations and a check of the drainage area on U.S.G.S. quad sheets, hydrologic analysis using U. S. Army Corps of Engineers guidelines was performed and appear in Appendix C as Sheets 1 through 9.

E. Structure:

The only structure associated with this dam is the restricted flow riser. Details of this riser appear as Sheet 10 of Appendix A.

2.2 CONSTRUCTION:

Inspection during the construction of the dam was performed by the Soil Conservation Service Office, Mount Vernon, Missouri, under the direction of Mr. Joe Green, Project Engineer. Mr. Green stated that daily inspection was performed during construction. The inspector's log and inspection tests, to include compaction and concrete testing, are currently on file at the Soil Conservation Service Office, Columbia, Missouri. The construction inspection data were not obtained.

2.3 OPERATION:

Normal flows would be passed by the restricted flow riser to the 30 inch diameter spillway pipe and the uncontrolled earthcut spillway.

2.4 EVALUATION:

A. Availability:

The engineering data available are as listed in Section 2.1.

B. Adequacy:

The engineering data available were inadequate to make a detailed assessment of the design, construction, and operation of this structure. Seepage and stability analyses comparable to the requirements of the "Recommended Guidelines for Safety Inspection of Dams" were not available, which is considered a deficiency. The seepage analyses should be performed for appropriate loading conditions (including earthquake loads) and made a matter of record.

C. Validity:

The As Built Plans and Soil Investigation data and test results prepared by the Soil Conservation Service included in Appendices A and B are valid engineering data on the design and construction of the dam.

SECTION 3 - VISUAL INSPECTION

3.1 FINDINGS:

A. General:

The field inspection was made on May 28, 1980. The inspection team consisted of personnel from Anderson Engineering, Inc. of Springfield, Missouri, and Hanson Engineers, Inc. of Springfield, Illinois. The team members were:

Steve Brady - Anderson Engineering, Inc., (Civil Engineer)
Tom Beckley - Anderson Engineering, Inc., (Civil Engineer)
Jack Healy - Hanson Engineers, Inc., (Geotechnical Engineer)
Nelson Morales - Hanson Engineers, Inc., (Hydraulic Engineer)

Photographs of the dam, appurtenant structures, reservoir, and downstream features are presented in Appendix D.

B. Dam:

The dam appears to be in good condition. No sloughing or sliding of the embankment was noted. The horizontal and vertical alignments of the crest were good, and no surfacing cracking or unusual movement was obvious. The crest of the embankment was 14 feet wide and the low crest elevation was 1002.9. The field survey data obtained by the inspection team compared favorably to the As Built Plans for this dam.

On the date of inspection, the pool level was about 0.1 feet above the upper orifice invert. The apparent high water mark observed on the riser structure was about 6 inches higher than normal pool elevation.

Shallow auger probes into the embankment indicated the fill material to be a reddish brown silty clay (CL). The embankment has a good grass cover and appears to be in good condition. Some erosions was observed in some areas of the embankment where the grass cover is light. No sloughing of the embankment or seepage through the embankment was evident. No animal burrows were noted.

Water was observed along the toe of the embankment. The water appeared to be from the installed drains and the spring along the toe of the embankment. The standing water on the downstream berm appeared to be due to inadequate surface drainage provided for the berm.

No rip rap was noted on the upstream face of the embankment at normal pool level.

The water level of the three piezometers was checked by the inspection team. The water elevations are recorded on Sheet 3 of Appendix A.

Benchmark #1 (See Sheet 6 of Appendix A) was used as the datum for the field survey.

C. Appurtenant Structures:

C.1 Principal Spillway:

The principal spillway consisting of the 30 inch reinforced concrete spillway pipe and associated flow restrictor riser is in good condition. The 12 inch diameter slide gate appeared to be in good working condition.

The approach to the inlet structure was clear. Considerable rip rap was placed around the inlet structure.

C.2 Emergency Spillway:

The emergency spillway was located at the west abutment. The spillway channel appeared to be an earth cut channel. The grass cover in the channel was good with some erosion channels observed. The spillway has not been used since the dam was constructed. Continued use of the spillway would probably result in erosion of the topsoil.

The outlet channel is directed well away from the embankment. The outlet and inlet channel were clear.

D. Reservoir.

The immediate periphery of the lake was wooded and grass covered with moderate slopes. The reservoir banks appeared to be in good condition with good grass cover. No appreciable sedimentation was noted.

E. Downstream Channel:

Immediately downstream of the embankment the channel is grass covered. The downstream channel is tree lined with moderate slope.

3.2 EVALUATION.

The grass cover on the embankment was fair to good with some erosion channels in the areas of light grass cover. No apparent seepage was observed, although standing water was present along the downstream toe and on the downstream berm.

No significant erosion was observed on the front face of the embankment at normal pool level.

Photographs of the dam, appurtenant structures, and the reservoir are presented in Appendix D.

SECTION 4 - OPERATIONAL PROCEDURES

4.1 PROCEDURES:

The operation and maintenance of the dam are the responsibility of the Lost Creek Watershed District Board in conjunction with the Soil and Water Conservation District, Neosho, Missouri. For the first three years after construction of the dam, a joint inspection is being conducted by members of the District Board and the Soil Conservation Service. After three years the District Board is responsible for providing yearly inspections. In addition to the annual inspection, the dam is to be inspected after each severe flood and after the occurrence of any other unusual conditions which might adversely affect the structural measure. The inspection is to include the condition of principal spillway and its appurtenances, the emergency spillway, the earthfill and any other items installed as a part of the structure. Copies of the inspection report are forwarded to the Soil Conservation Service office in Springfield, Missouri. The last annual inspection was conducted on May 14, 1980, and the results are included as Sheet 12 of Appendix A.

4.2 MAINTENANCE OF DAM:

After the yearly inspection of the dam, the Lost Creek Watershed District Board determines the maintenance to be done. Monies for the required maintenance are derived from a tax levy imposed upon the residents of the Watershed District.

4.3 MAINTENANCE OF OPERATING FACILITIES:

The maintenance required for the restricted flow riser is accomplished after the yearly inspection by the Watershed District Board. The slide gate appeared to be in good condition.

4.4 DESCRIPTION OF ANY WARNING SYSTEM IN EFFECT:

The inspection team is unaware of any existing warning system for this dam.

4.5 EVALUATION:

The general maintenance of the dam and associated items appeared to be in good condition. The lack of wave protection near the upstream face was noted. Some erosion channels were forming in the area of light grass cover. Standing water was observed along the downstream toe and on the downstream berm.

SECTION 5 - HYDRAULIC/HYDROLOGIC

5.1 EVALUATION OF FEATURES:

A. Design Data:

The hydrologic and hydraulic design data for this dam are as shown on Sheet 11 of Appendix A.

B. Experience Data:

No recorded rainfall, runoff, discharge, or reservoir stage data were obtained for this lake and watershed. During the design phase, flood frequency used in evaluation of damages was obtained from six representative stream gauges in the surrounding area.

C. Visual Observations:

The approach channels to the spillway are clear. The emergency spillway is well separated from the embankment, and spillway releases would not be expected to endanger the dam. Spillway flows through the principal spillway pipe could result in erosion of the downstream channel.

D. Overtopping Potential:

The hydraulic and hydrologic analyses (using the U. S. Army Corps of Engineers guidelines and the HEC-1 computer program) were based on (1) a field survey of spillway dimensions and embankment elevations; (2) an estimate of the reservoir storage and the pool and drainage areas from the Racine, Missouri, 7.5 Minute U.S.G.S. quad sheet, and (3) data obtained from the As Built Plans for this project (See Appendix A, Sheets 6 through 11).

Based on the hydrologic and hydraulic analysis presented in Appendix C, the combined spillways will pass 70 percent of the Probable Maximum Flood. The Probable Maximum Flood is defined as the flood discharge that may be expected from the most severe combination of critical meteorologic and hydrologic conditions that are reasonably possible in the region. The recommended guidelines from the Department of the Army, Office of the Chief of Engineers, require that this structure (intermediate size with high downstream hazard potential) pass the PMF, without overtopping. The PMF has been determined to be the appropriate spillway design flood. The structure will pass a 1 percent probability flood without overtopping.

Application of the probable maximum precipitation (PMP), minus losses, resulted in a flood hydrograph peak inflow of 8781 cfs. For 50 percent of the PMP, the peak inflow was 4390 cfs.

The routing of the PMF through the spillways and dam indicates that the dam will be overtopped by 1.46 feet at elevation 1004.36. The duration of the overtopping will be 1.0 hours, and the maximum outflow will be 7507 cfs. The maximum discharge capacity of the spillways is 4918 cfs. The routing of 50 percent of the PMF indicates that the dam will not be overtopped. The maximum outflow will be 3166 cfs. Overtopping of an earthen embankment could cause serious erosion and could possibly lead to failure of the structure.

SECTION 6 - STRUCTURAL STABILITY

6.1 EVALUATION OF STRUCTURAL STABILITY:

A. Visual Observations:

Observed features which could adversely affect the structural stability of this dam are discussed in Sections 3.1B and 3.2.

B. Design and Construction Data:

Design data obtained are included in Appendix A. Analysis of the soil structure is included in Appendix B. Additional design data and construction notes and test results are located at the Soil Conservation Service in Columbia, Missouri.

Seepage and stability analysis comparable to the requirements of the guidelines were not available, which constitutes a deficiency which should be rectified.

C. Operating Records:

The piezometers are normally read and recorded weekly and after each storm. The resulting readings are on file in the Columbia, Missouri Soil Conservation Service Office. Verbal information from that office indicated that the water elevations for the east piezometer were maximum 950.6 (April, 1980), minimum 948.4 (February, 1980), mean 949.5. The center piezometer was maximum 957.2 (May, 1980), minimum 955.6 (March, 1980), mean 956.5, the west piezometer was maximum 964.7 (April, 1980), minimum 963.7 (March, 1980), mean 964.2. On the date of inspection the elevations recorded were east piezometer - 948.8, center piezometer - 958.3 and west piezometer 960.7.

As the lake has been full for only about 6 months and rainfall has been slight, no noticeable trends have been observed by the Soil Conservation Service. Thus far the east piezometer appears to fluctuate depending upon the amount of rainfall.

D. Post-Construction Changes:

There have been no reported post construction changes to this dam.

E. Seismic Stability:

The structure is located in seismic zone 1. An earthquake of this magnitude would not generally be expected to cause severe structural damage to a well constructed earth dam of this size. However, it is recommended that the prescribed seismic loading for this zone be applied in stability analyses performed for this dam.

SECTION 7 - ASSESSMENT/REMEDIAL MEASURES

7.1 DAM ASSESSMENT:

This Phase I inspection and evaluation should not be considered as being comprehensive since the scope of work contracted for is far less detailed than would be required for an in-depth evaluation of dams. Latent deficiencies, which might be detected by a totally comprehensive investigation, could exist.

A. Safety:

The embankment is in good condition. Some items were noted during the visual inspection which should be investigated further, corrected or controlled. These items are: (1) standing water on downstream berm; (2) standing water along the downstream toe of embankment; and (3) some erosion on the embankment slopes.

Another deficiency was the lack of seepage and stability analyses comparable to the recommended guidelines.

The dam will be overtopped by flows in excess of 70 percent of the Probable Maximum Flood. Overtopping of an earthen embankment could cause serious erosion and could possibly lead to failure of the structure.

B. Adequacy of Information:

The conclusions in this report were based on review of the information listed in Section 2.1, the performance history as related by others, and visual observation of external conditions. The inspection team considers that these data are sufficient to support the conclusions herein. Seepage and stability analyses comparable to the "Recommended Guidelines for Safety Inspection of Dams" were not available, which is considered a deficiency.

C. Urgency:

The remedial measures recommended in paragraph 7.2 should be accomplished in the near future. If the deficiencies listed in paragraph A are not corrected, and if good maintenance is not provided, the embankment condition will deteriorate and possibly could become serious in the future. The items recommended in paragraph 7.2A should be pursued without undue delay.

D. Necessity for Additional Inspection:

Based on the result of the Phase I inspection, no additional inspection is recommended.

E. Seismic Stability:

The structure is located in seismic zone 1. An earthquake of this magnitude would not generally be expected to cause severe structural damage to a well constructed earth dam of this size. However, it is recommended that the prescribed seismic loading for this zone be applied in any stability analyses performed for this dam.

7.2 REMEDIAL MEASURES:

The following remedial measures and maintenance procedures are recommended. All remedial measures should be performed under the guidance of a professional engineer experienced in the design and construction of dams.

A. Alternatives:

Spillway size and/or height of dam should be increased to pass the PMF. In either case, the spillway should be protected to prevent erosion.

B. O & M Procedures:

- (1) Seepage and stability analyses comparable to the requirements of the recommended guidelines should be performed by an engineer experienced in the construction of dams.
- (2) Vegetative growth on the dam should be maintained and cut annually.
- (3) Wave protection should be provided for the upstream face of the embankment.
- (4) the downstream berm should be graded to allow egress of surface water.
- (5) The water at the downstream toe should be observed periodically to determine any increase in flow.
- (6) A detailed inspection of the dam should be made periodically by an engineer experienced in the design and construction of dams.

APPENDIX A

Dam Location and Plans

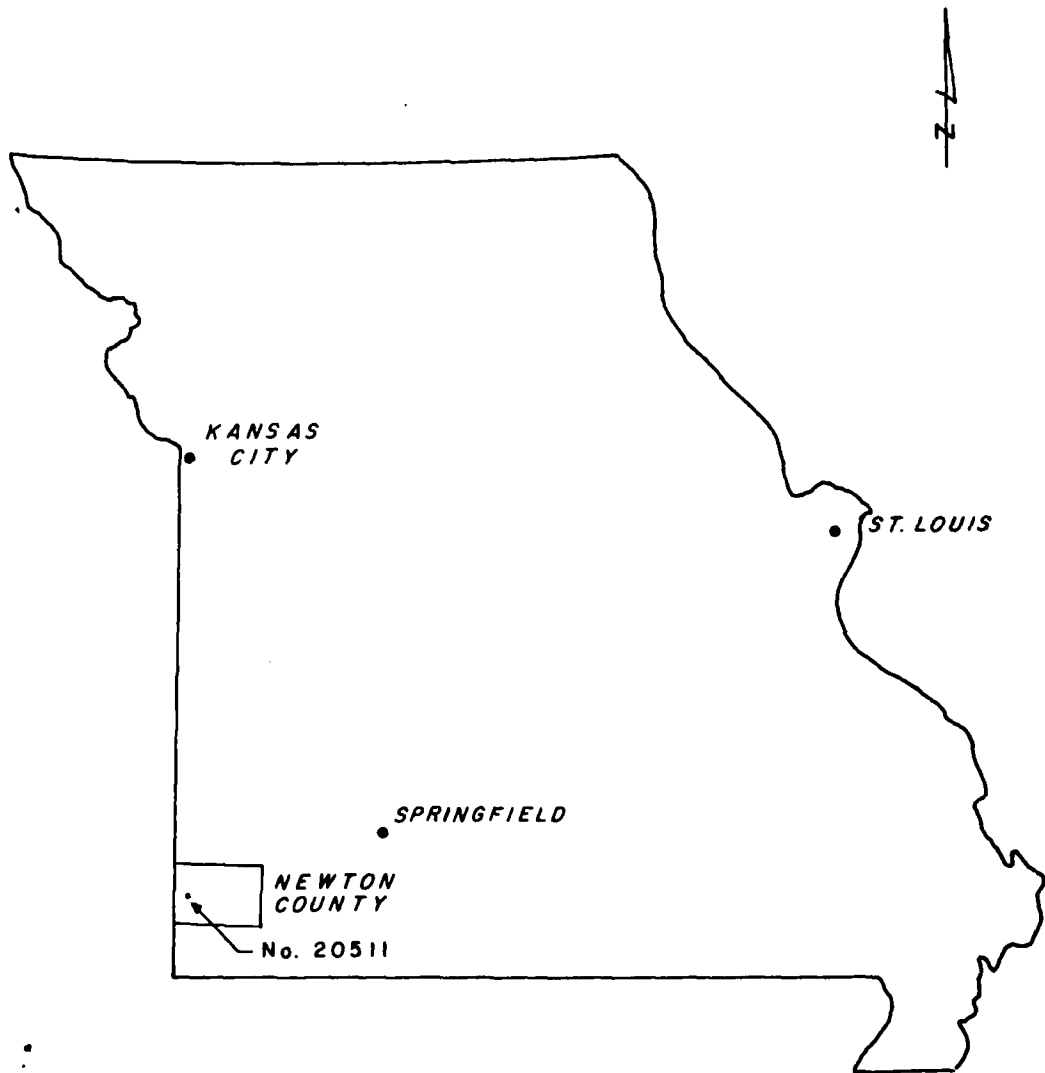

LOCATION MAP

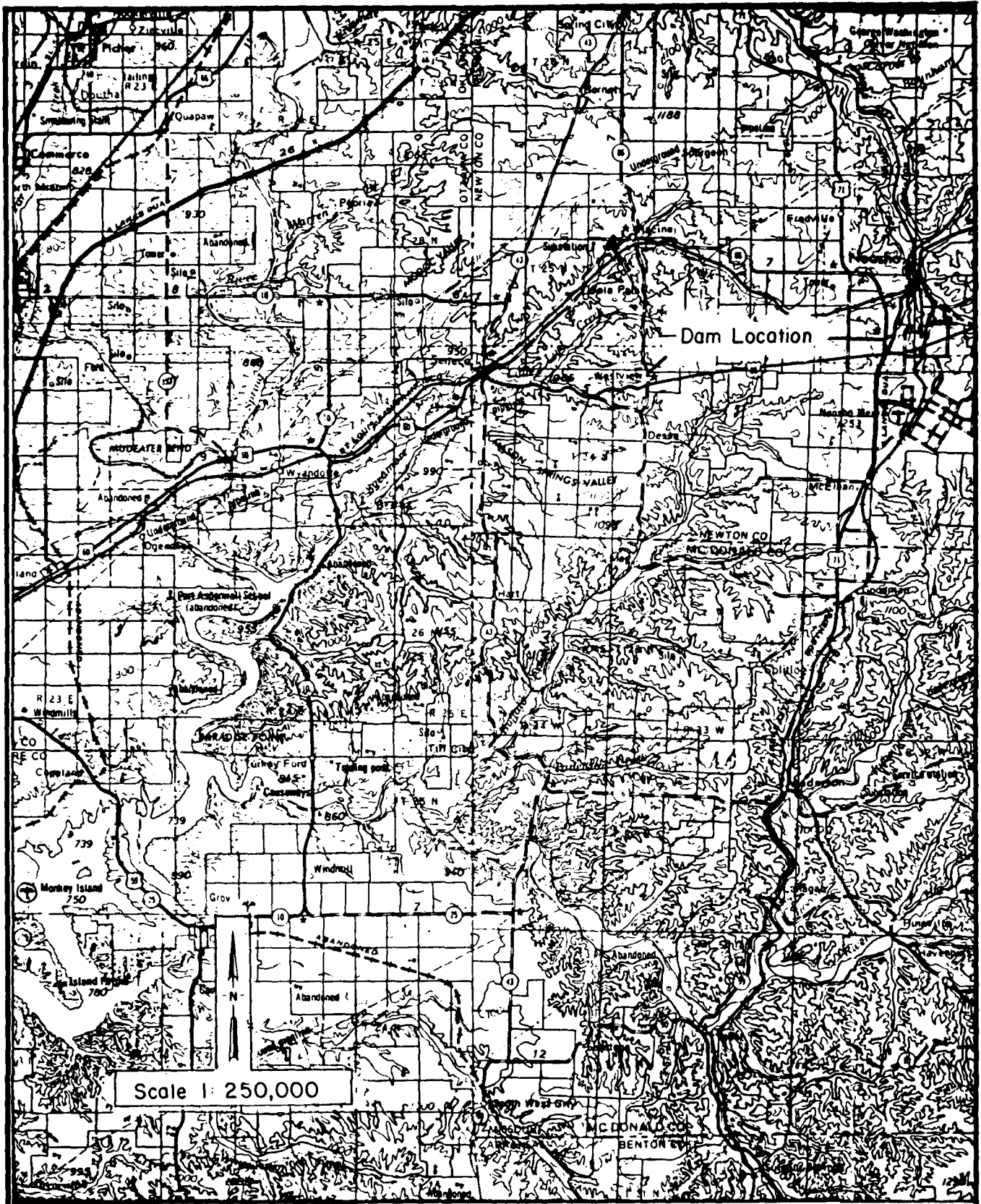

VICINITY MAP



SPRINGFIELD, IL • PEORIA, IL • ROCKFORD, IL

Newton County Structure E-1 Dam
 Newton County, Missouri
 Mo. I.D. No. 20511

Sheet 2, Appendix A

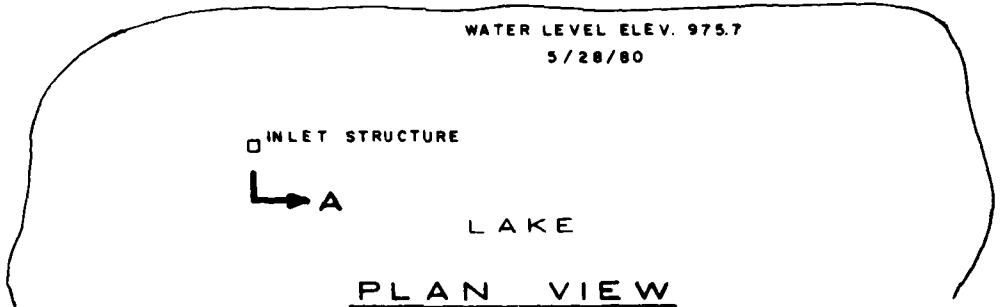
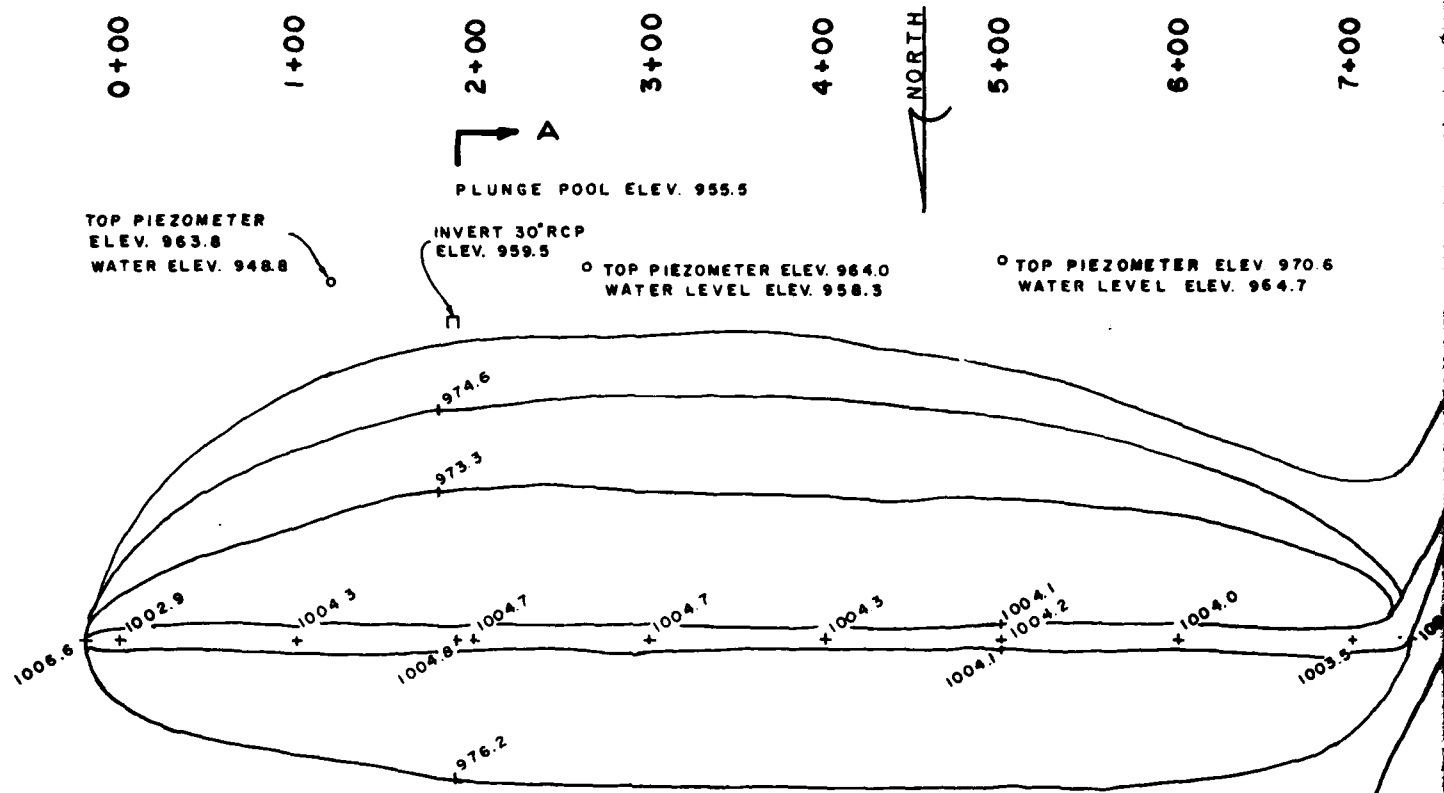

PLAN VIEW
SCALE: 1" = 100'

BENCHMARK: #1
CONCRETE MONUMENT 50' LEFT
OF STA 0+00 \oslash DAM
ELEV. = 1005.3

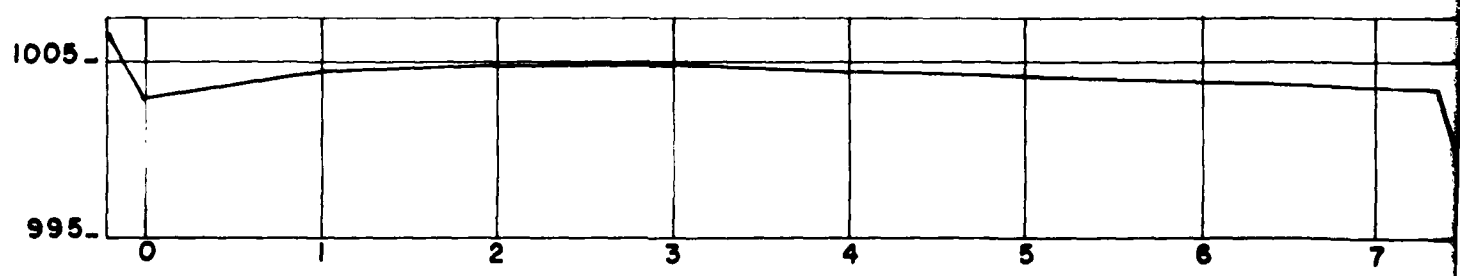

PROFILE

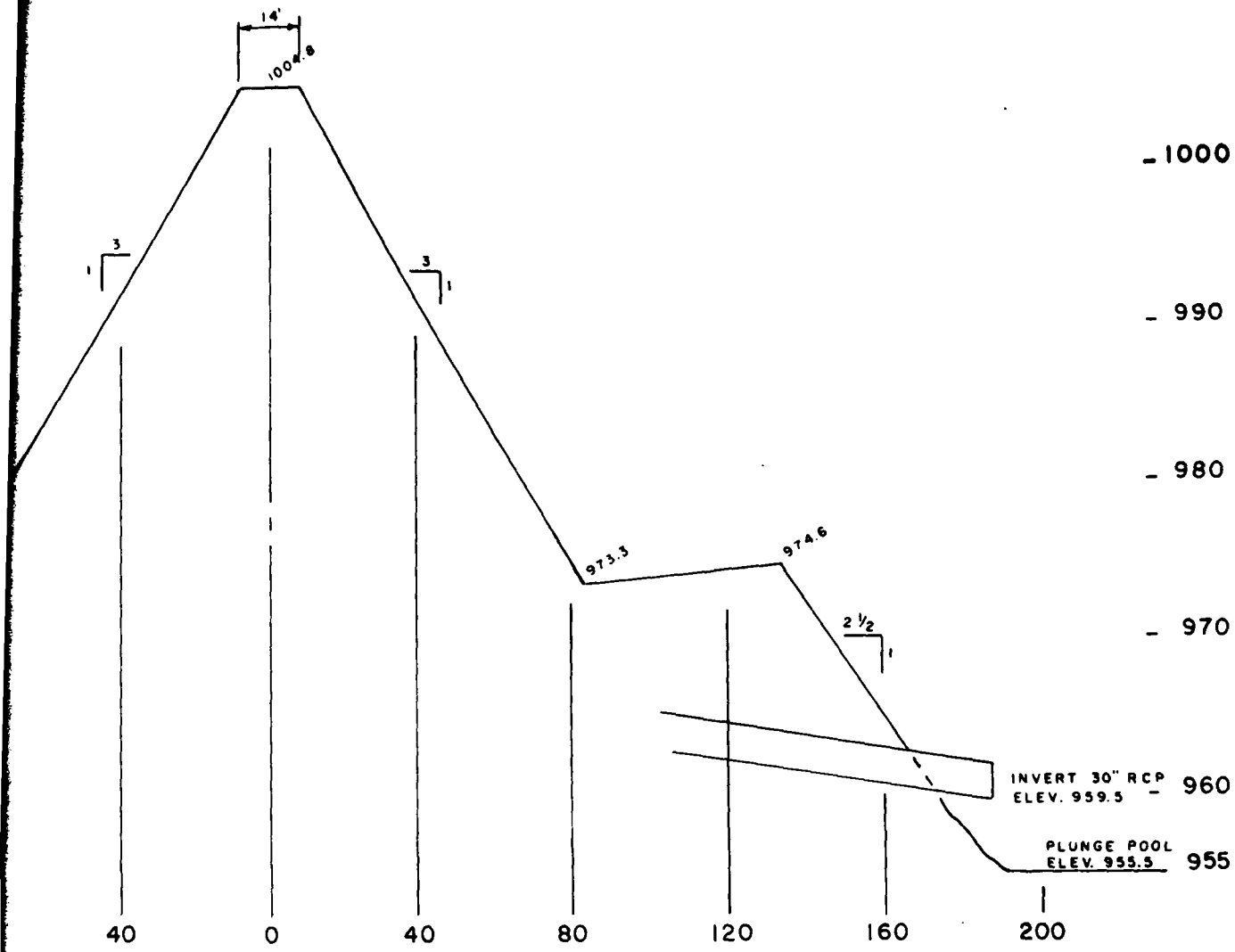

SECTION A-A STA 1+90

SHEET 3 APPENDIX A

ANDERSON ENGINEERING, INC.
 730 NORTH BENTON AVENUE
 SPRINGFIELD, MISSOURI 65802

NEWTON COUNTY STRUCTURE E-1
 MO. No. 20511

PLAN & PROFILE

NEWTON COUNTY, MO.



SPILLWAY SECTION
25 FT. LEFT $\&$ DAM

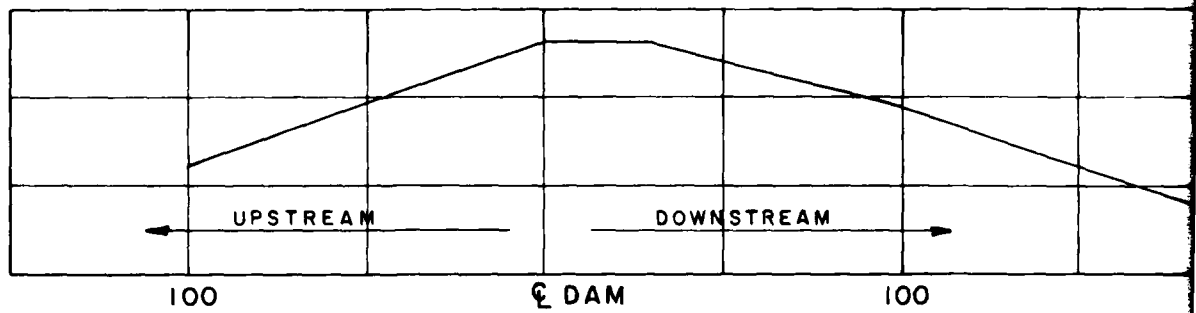

SPILLWAY PROFILE

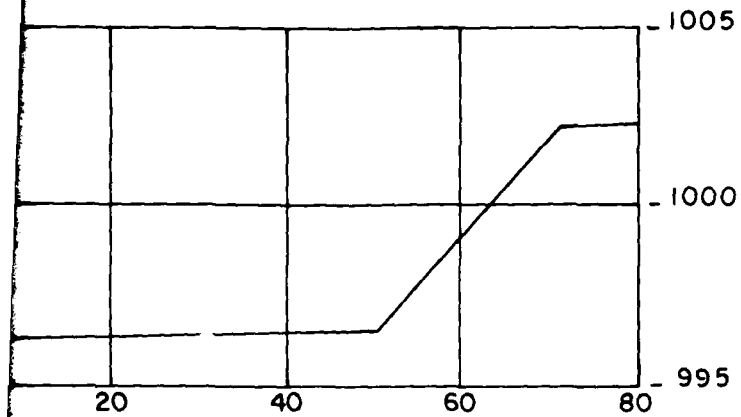

CROSS SECTION
DAM

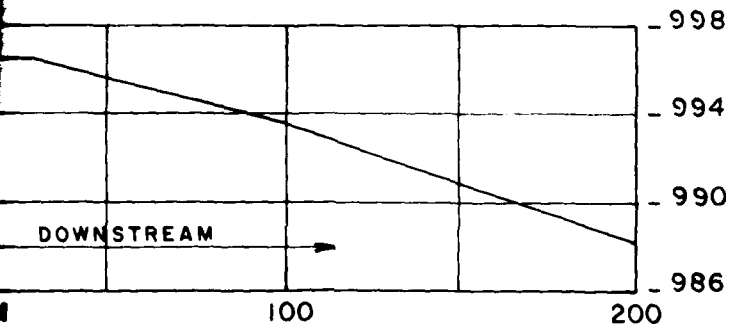

DOWNSTREAM PROFILE

SHEET 3A APPENDIX A

ANDERSON ENGINEERING, INC.
730 NORTH BENTON AVENUE
SPRINGFIELD, MISSOURI 65802

NEWTON COUNTY STRUCTURE E-1

MO. No. 20511

SPILLWAY
SECTION & PROFILE

NEWTON COUNTY, MO.

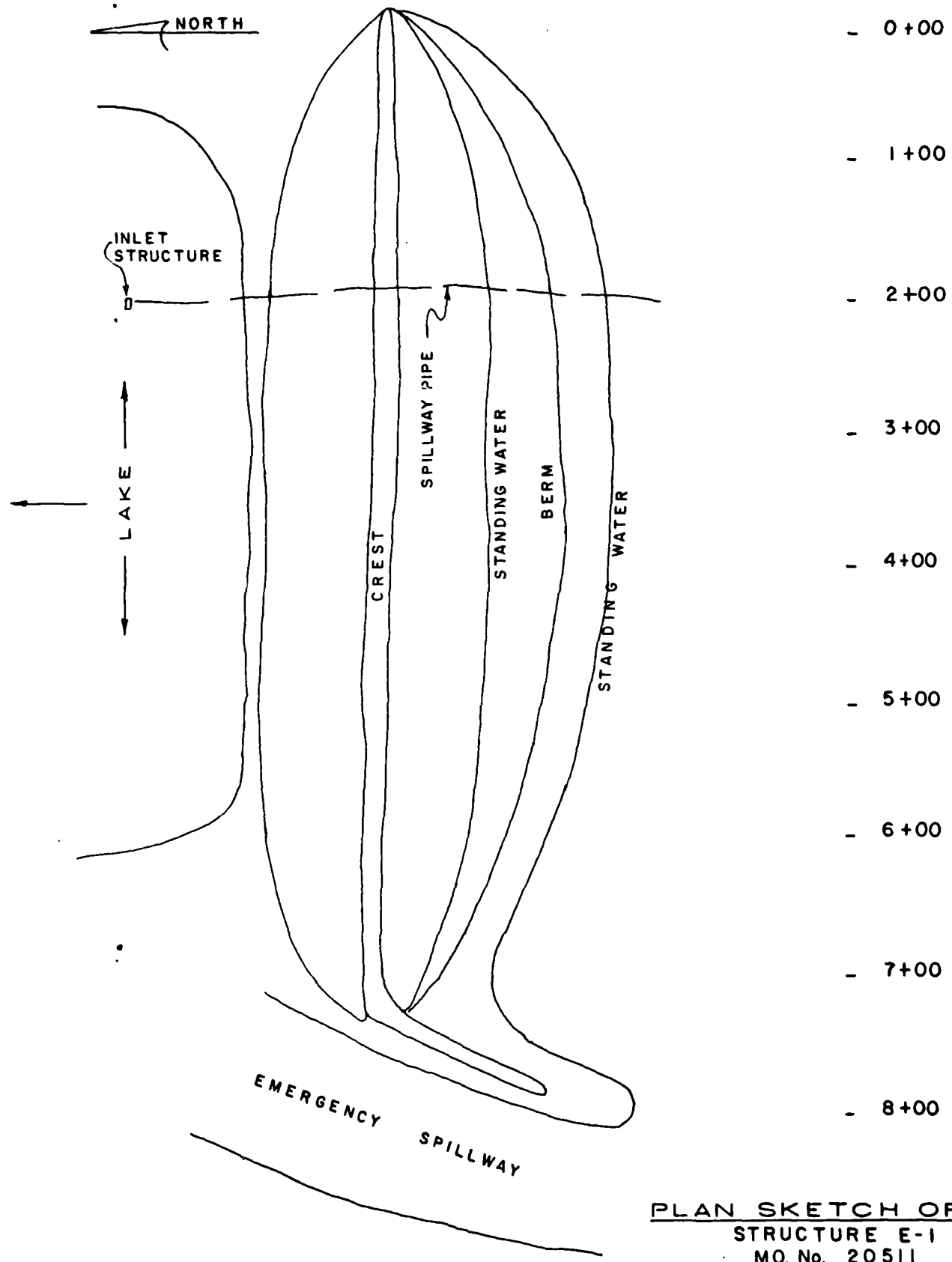

PLAN SKETCH OF DAM
 STRUCTURE E-1
 MO. No. 20511

- LEGEND**
- WATERSHED BOUNDARY
 - DRAINAGE AREA CONTROLLED BY STRUCTURE
 - AREA BENEFITED
 - PROJECT MEASURES**
 - STRUCTURE NUMBER
 - FLOODWATER RETARDING STRUCTURE
 - DEBRIS BASIN STRUCTURE
 - PROPOSED FLOOD CHANNEL CORPS OF ENGINEERS
 - ECONOMIC EVALUATION REACH

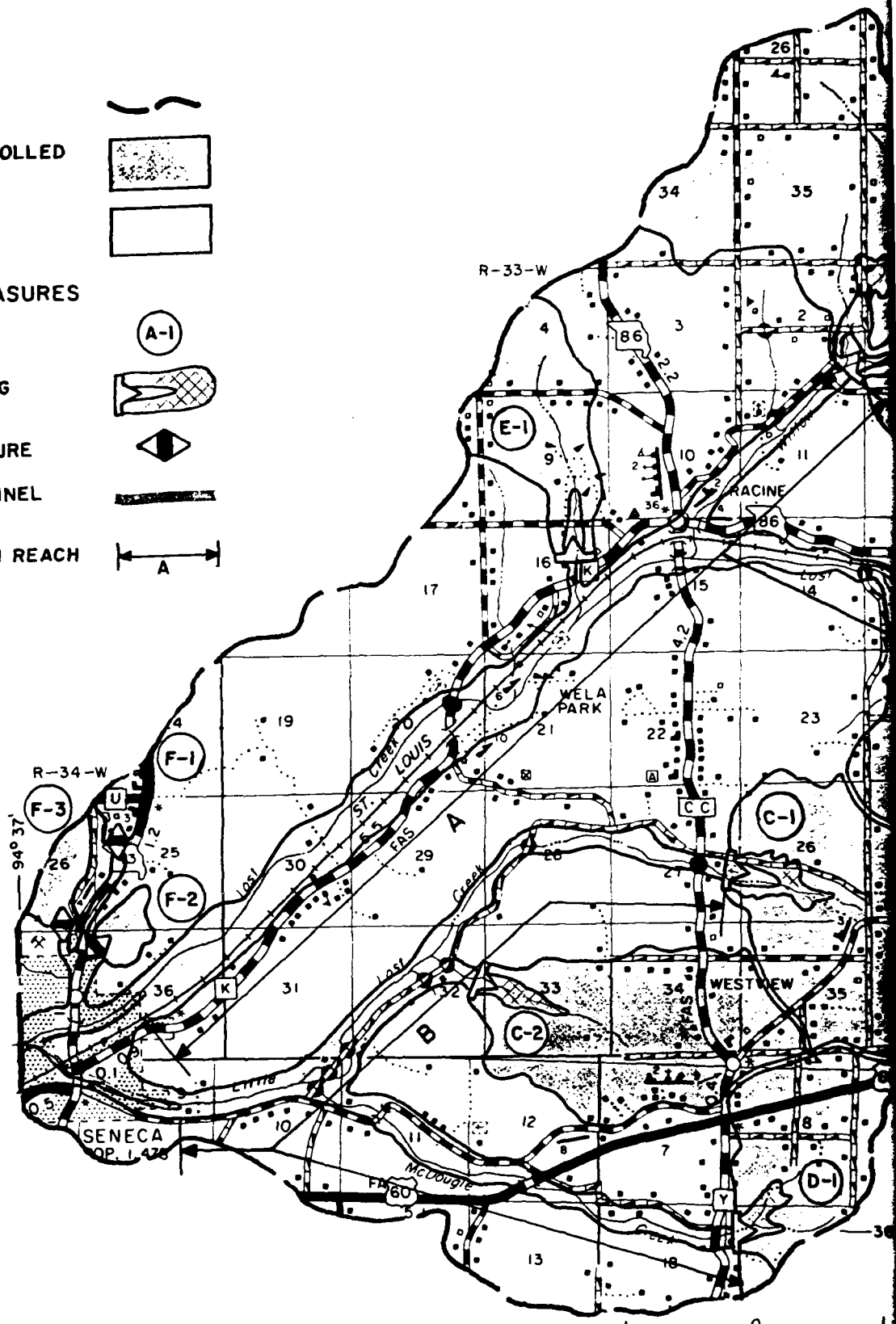
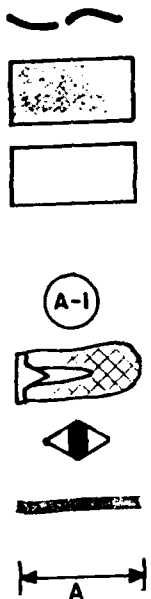

SOURCE
SCS BASE 5,0-28,307 AND DATA
FURNISHED BY FIELD TECHNICIANS

POLYCONIC PROJECTION

SCALE 1" = 1 MILE

WDA SCS-LINCOLN FEB 1970

PROJECT MAP LOST CREEK WATERSHED NEWTON COUNTY, MISSOURI

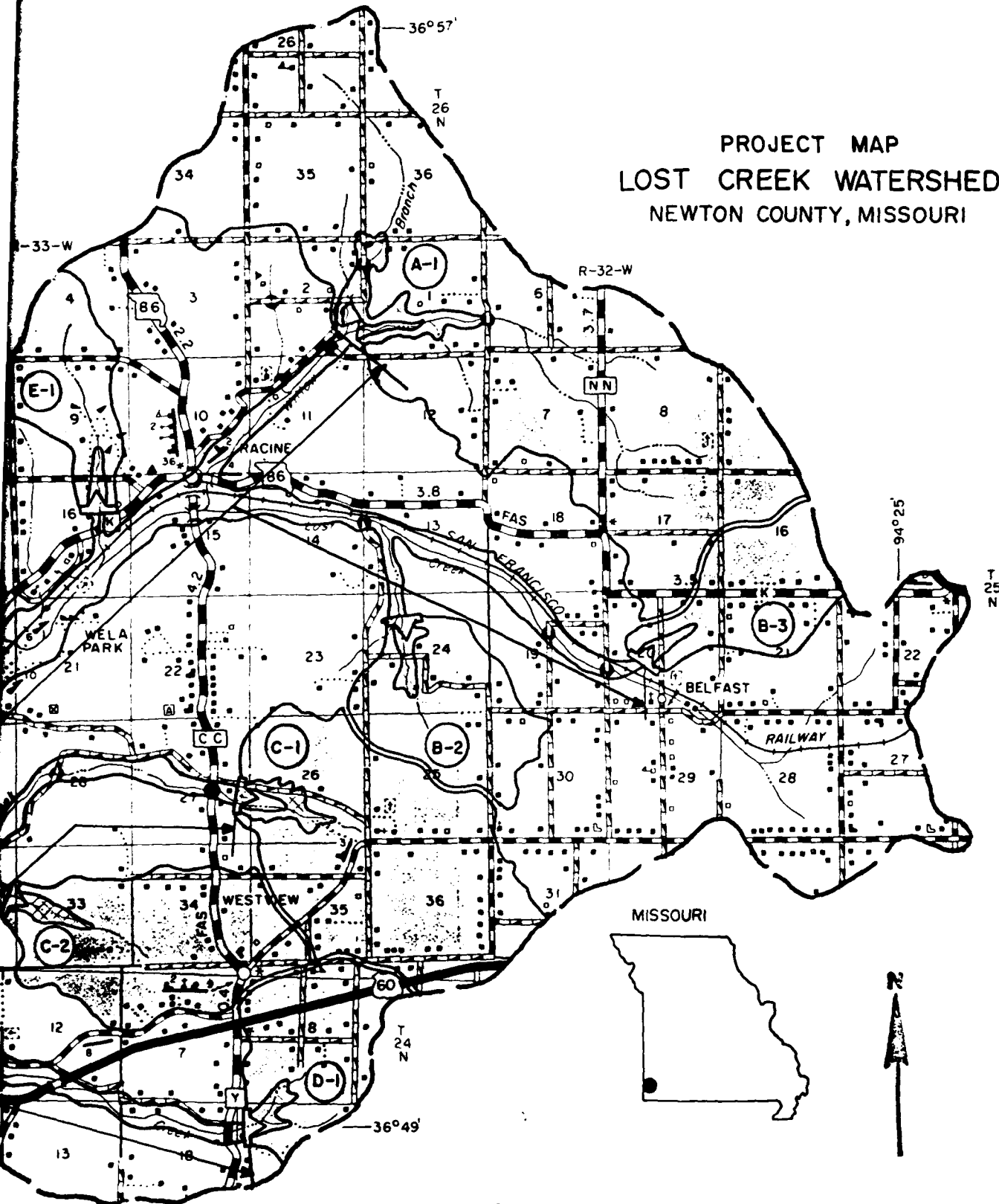

PROJECTION

SCALE 1/70,000

7-2-70
5,0-28,312

DATA TABLE

Drainage Area, Acres	736
Sediment Storage, Acre feet	60
Retarding Storage, Acre feet	398
Sediment Pool, Acres	9.5
Retarding Pool, Acres	31.2



TBM #6 Elev 959.18 Chiseled on corner of south headwall of culvert under Route "X", approx. 500' southeast of Buzzard's house.

B.M. #1 Elev 1005.30 Concrete Monument 50' Lt of Sta 0+00 E Dam.

Em #2, 3, 4, 5, 6, 7, 8, 9, 10, 11, 12, 13, 14, 15, 16, 17, 18, 19, 20, 21, 22, 23, 24, 25, 26, 27, 28, 29, 30, 31, 32, 33, 34, 35, 36, 37, 38, 39, 40, 41, 42, 43, 44, 45, 46, 47, 48, 49, 50, 51, 52, 53, 54, 55, 56, 57, 58, 59, 60, 61, 62, 63, 64, 65, 66, 67, 68, 69, 70, 71, 72, 73, 74, 75, 76, 77, 78, 79, 80, 81, 82, 83, 84, 85, 86, 87, 88, 89, 90, 91, 92, 93, 94, 95, 96, 97, 98, 99, 100

RALPH FREY

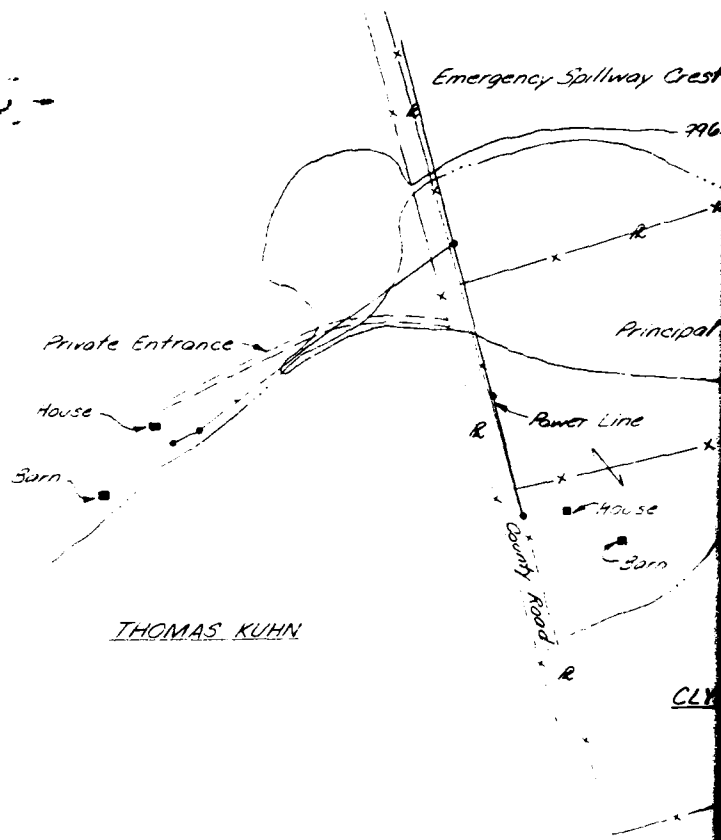

Structure E-1 is located approx 1/4 mile west and 1/4 mile south of Racine, Missouri in the north 1/2 of Sec 16 and south 1/2 of Sec 9, T 25 N, R 32 W.

THOMAS KUHN

QUANTITIES
 Clearing & Grubbing ----- Lump Sum
 (Approx 8.9 Acres)

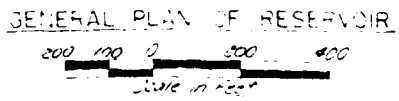

GENERAL PLAN OF RESERVOIR

LEGEND
 Existing Fence ——— x ——— x ———
 Fence to be Removed ——— o ——— o ———
 Clearing & Grubbing ——— [stippled area] ———
 Ingress-Egress Route ——— [dotted line] ———

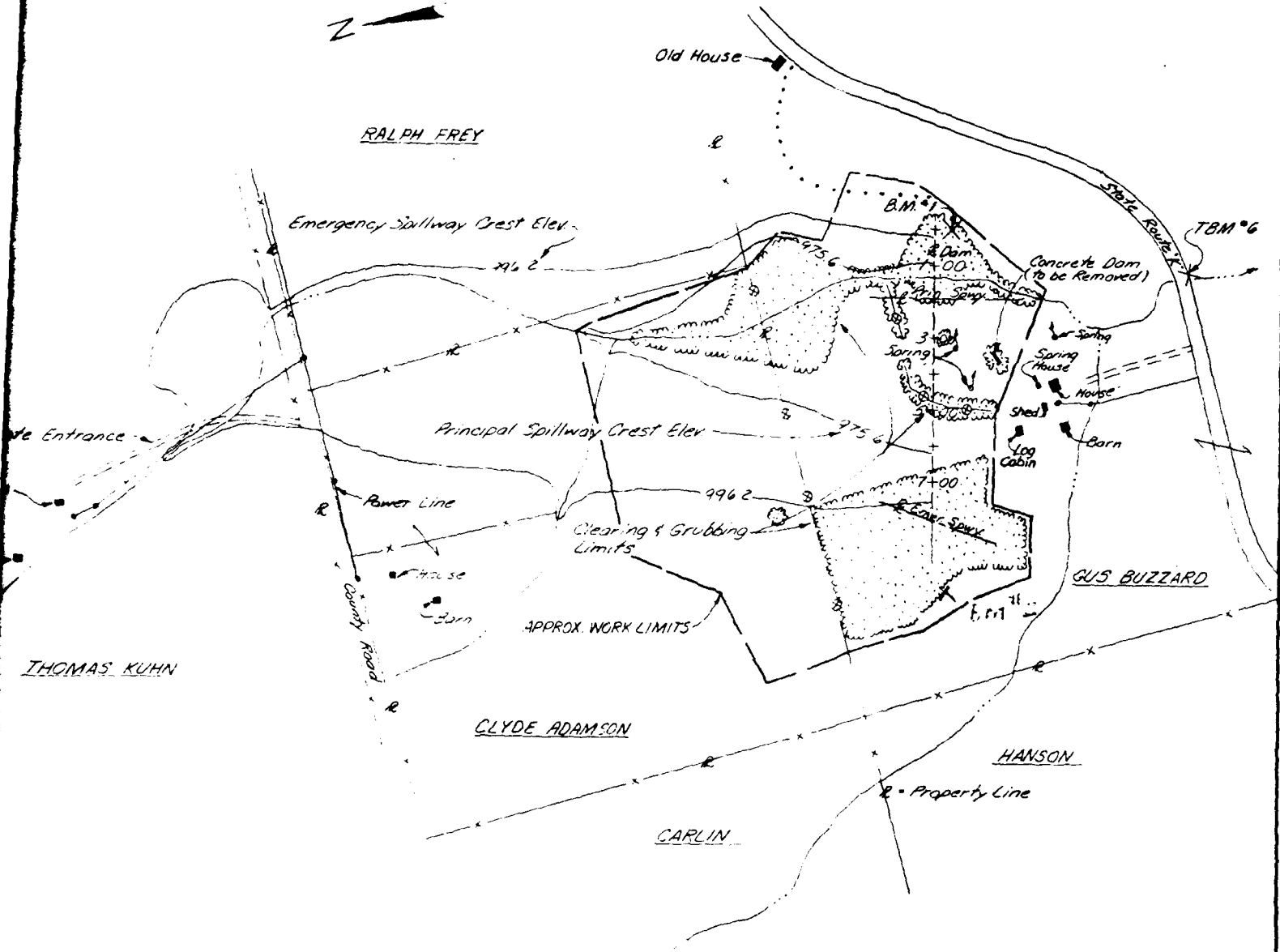

GENERAL PLAN OF RESERVOIR
 200 100 0 200 400
 Scale in Feet

STRUCTURE E-1		
LOST CREEK WATERSHED PL.566		
NEWTON COUNTY, MISSOURI		
U. S. DEPARTMENT OF AGRICULTURE		
SOIL CONSERVATION SERVICE		
Drawn by J. A. G.	11-75	Approved by
Drawn by C. O. J.	11-75	Checked by
Drawn by B. A. E.	9-75	Field Notes
Drawn by M. V. B. B. E. S.	9-75	5.5.8.8.1

2

Sheet 6 of Appendix A

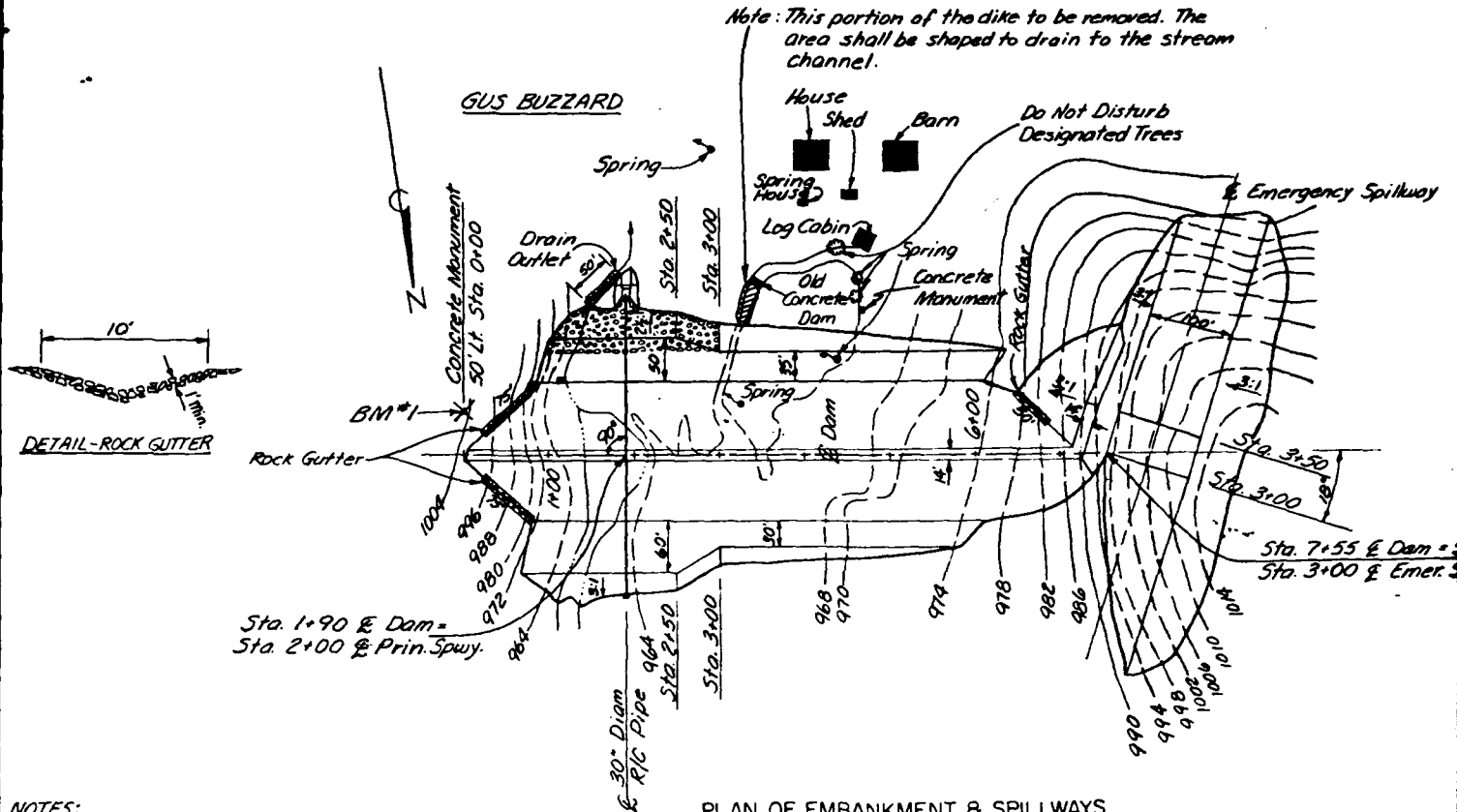

PLAN OF EMBANKMENT & SPILLWAYS
 100 50 0 100 200
 Scale in Feet

NOTES:

Topsoil

A minimum of six (6) inches of topsoil is to be placed on all compacted earth fill and in the earth portion of the emergency spillway.

Downstream Berm

The downstream berm has no longitudinal grade. Control elevations are shown on sheet 4.

Rock Gutters

Rock gutters shall be constructed with rock removed from the emergency spillway. The rock gutters are designated as rock fill.

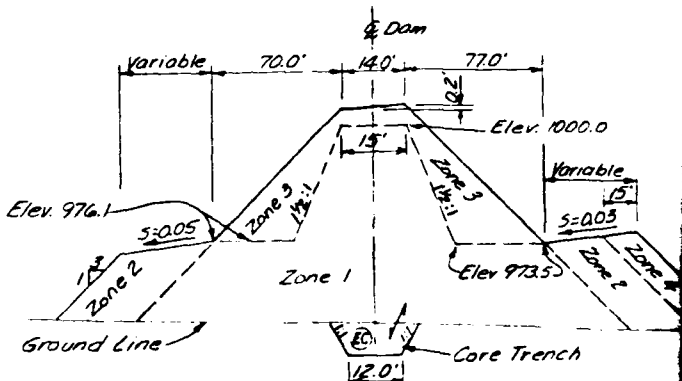

TYPICAL SECTION OF EMBANKMENT

EMBANKMENT MATERIAL SOURCES AND PLACEMENT REQUIREMENTS									
ZONE	LOCATION	SOURCE OF MATERIAL		PLACEMENT & MOISTURE DENSITY REQUIREMENTS					
		APPROX DEPTH	UNIFIED SOIL CLASS.	LIFT THICKNESS	MAX SIZE	COMP CLASS	COMP CONTROL	COMP REQ'D	ALLOWABLE MOISTURE
1	Borrow Area	3' - 6'	CL or SC	9"	6"	A	ASTM D-2922 Method C	95%	100% minimum 1 1/2" above
1	Emergency Spillway	4' - 6'	CH	9"	6"	A	ASTM D-2922 Method A	95%	100% minimum 1 1/2" above
2	Emergency Spillway	0' - 4'	GS, SP, SM	9"	6"	C	3 Passes	---	---
3	Emergency Spillway	0' - 3'	ML	9"	6"	A	ASTM D-2922 Method B	95%	100% minimum 1 1/2" above
4	Emergency Spillway	3' - 6'	CL or SC	36"	18"	III	---	---	---

NOTES:

1. The borrow area will only be excavated to the top of the pool area. The ML, CL and SC materials are the only materials to be used.
2. The CH material shall be placed in the upstream portion of the spillway.
3. Class C fill shall be compacted by 3 passes of a standard rammer with a minimum force of 200 psi.
4. If the CL, GM and GP materials are exhausted before the material shall be used with Class A compaction to the maximum density.
5. Zone 4 fill is only required in the 50' wide portion of the spillway.
6. The hard compacted fill placed around the pipe in 4 inch lifts.

Position of the dike to be removed. The dike will be shaped to drain to the stream.

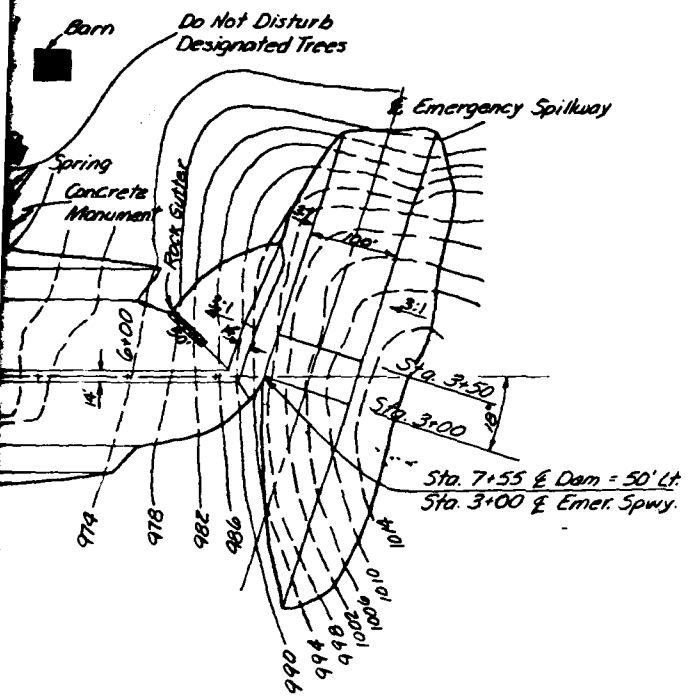

EMBANKMENT & SPILLWAYS

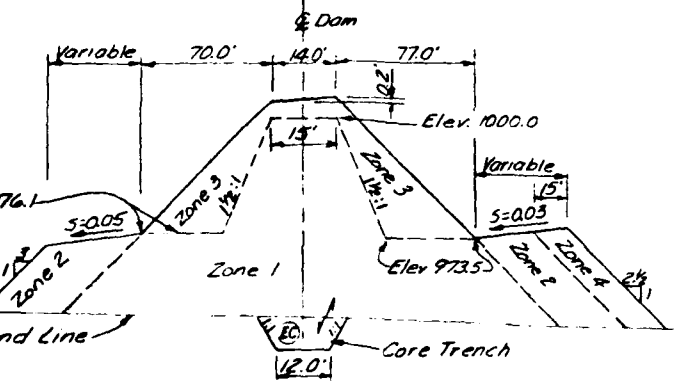

TYPICAL SECTION OF EMBANKMENT

QUANTITIES	
Excavation, Common (C)	2387
Core Trench	1070
Structure	1304
Stream Channel	1304
Stilling Basin & Outlet Channel	1304
Total	4824

Excavation, Rock (R)	2497
Emergency Spillway	2497

Earth Fill	
Class A	99,959
Class C	13,524

Rock Fill	1568
-----------	------

Topsoil	5356
---------	------

Seeding	14.2
Mulching	28.4
Temporary Seeding	2

5356 * 6,600 Sq. Yds. topsoil at a depth of six (6) inches = 35,300 Cu. Yds.

893

- NOTES:**
- The borrow area will only be excavated to the top of the CH material in the Sediment Pool area. The ML, CL and SC materials are the only materials to be borrowed.
 - The CH material shall be placed in the upstream portion of Zone 1 and below elevation 970.0.
 - Class C fill shall be compacted by 3 passes of a standard tamping roller exerting a minimum force of 200 lbs.
 - If the SC, GM and GP materials are exhausted before the Zone 2 is complete CL or SC material shall be used with Class A compaction to complete the upstream Zone 2.
 - Zone 4 fill is only required on the 50' wide portion of the downstream berm, Sta. 1+00 to Sta. 3+50.
 - The hard compacted berm placed around the principal spillway shall be placed in 2 inch lifts.

STRUCTURE E-1
LOST CREEK WATERSHED P.L. 566
NEWTON COUNTY, MISSOURI

U. S. DEPARTMENT OF AGRICULTURE
SOIL CONSERVATION SERVICE

Designed: M.M.B. N.M.R. Checked: J.P. Powell
 Drawn: B.E.S. Design Section
 Title: 1-77
 Date: 3-27-77 5/30/77
 N.M.R.

PIPE CAMBER TABLE	
Distance From Outlet	Elevation
0	959.50
16	959.69
24	959.78
40	959.97
56	960.15
72	960.34
88	960.63
104	960.90
120	961.16
136	961.39
152	961.63
168	961.85
184	962.04
200	962.22
216	962.39
232	962.53
248	962.68
264	962.81
280	962.93
296	963.04
312	963.13
328	963.32
344	963.51
352	963.60

NOTES:

1. Pipe elevations other than those shown will be furnished by the Engineer, when required.
2. Antiseep collars shall not be placed closer than (2) feet to a pipe joint.

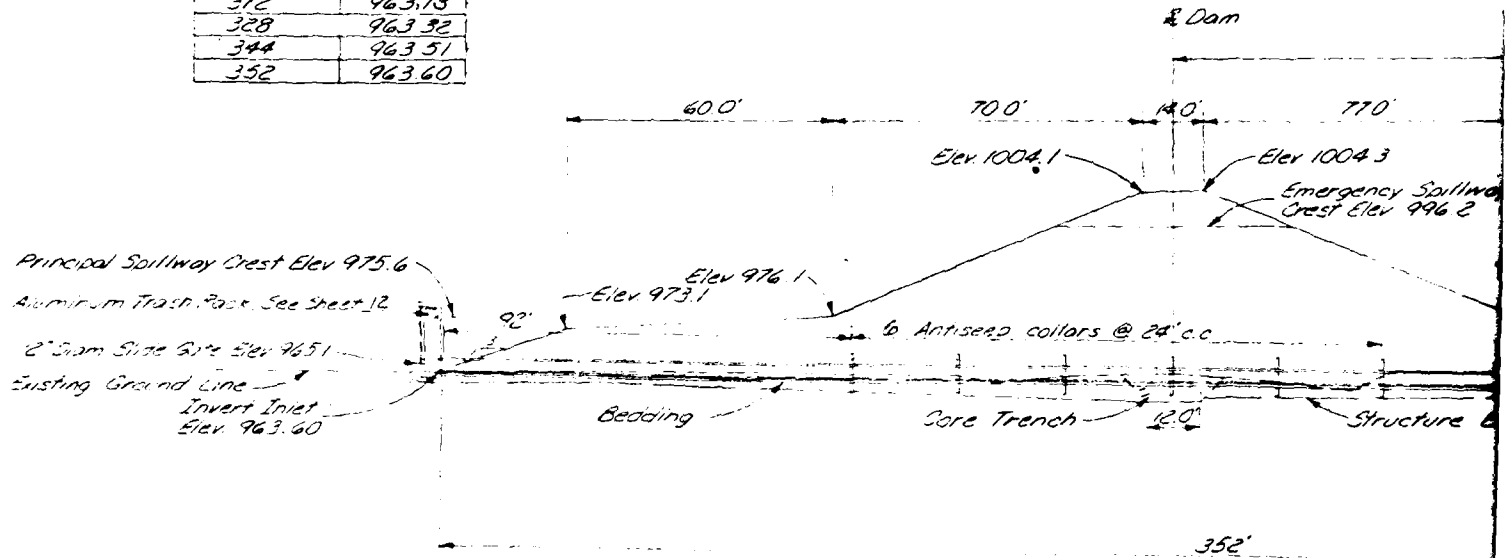

SECTION ON CENTERLINE

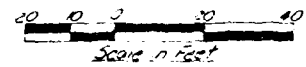

MATERIALS

- Concrete Class 4000
- Steel Bar Reinforcement
- Prestressing Concrete Pressure Pipe, 30" Diam, Steel Cylinder Type
- Aluminum Trash Rack
- Slide Gate 12" Diam

NOTES:

1. Pipe elevations other than those shown will be furnished by the Engineer, when required.
2. Antiseep collars shall not be placed closer than (2) feet to a pipe joint.

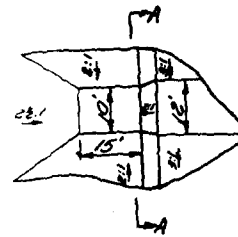
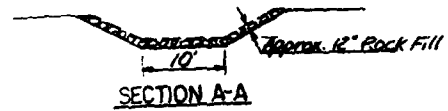

PARTIAL PLAN - OUTLET CHANNEL

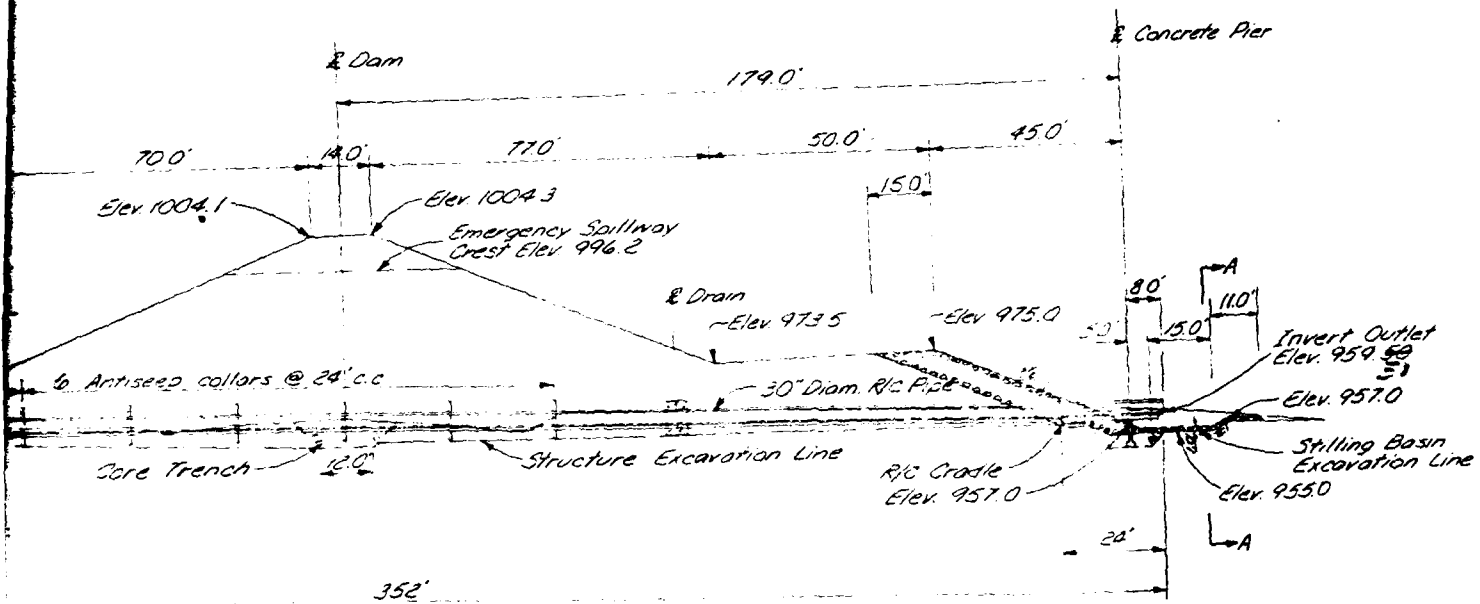

SECTION ON CENTERLINE

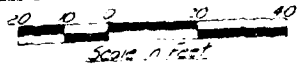

MATERIALS

30" Dia. Steel Cylinder Type

- 582 Cr. Kts
- 3,489 Pounds
- 352 Lin Ft
- Comp. Sum
- 1 Each

STRUCTURE E-1

R/C DROP INLET FOR 30" DIAM. PIPE
 GENERAL LAYOUT
 LOST CREEK WATERSHED P.L. 566
 NEWTON COUNTY, MISSOURI

U. S. DEPARTMENT OF AGRICULTURE
 SOIL CONSERVATION SERVICE

Drawn: M.M.H.
 Date: 8-1-56

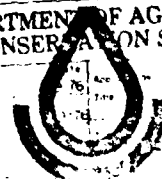

U. S. DEPARTMENT OF AGRICULTURE

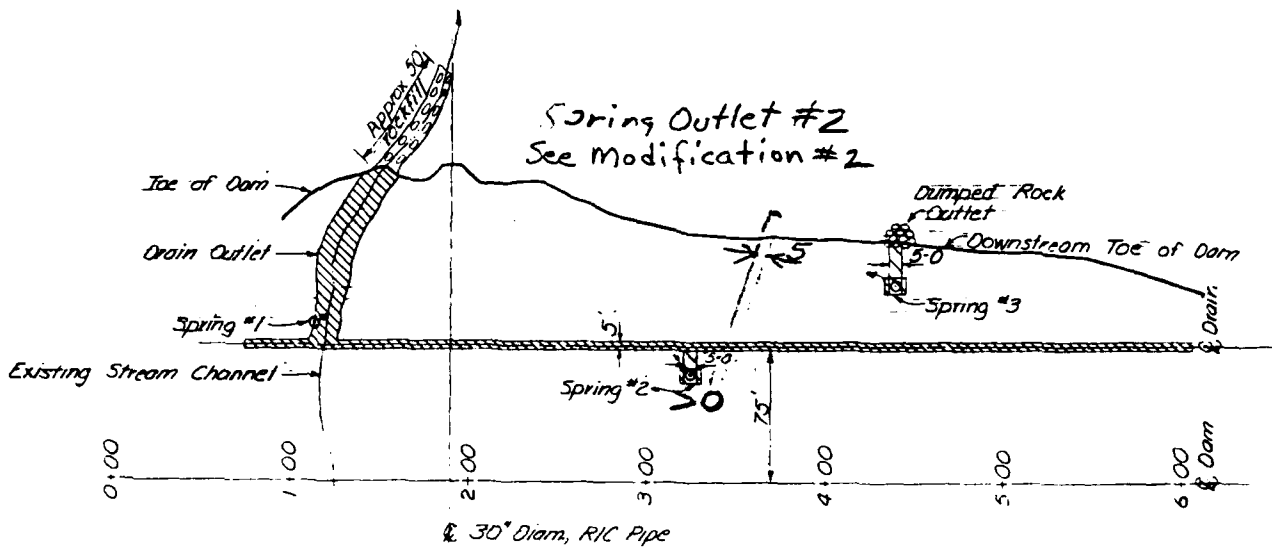

PLAN

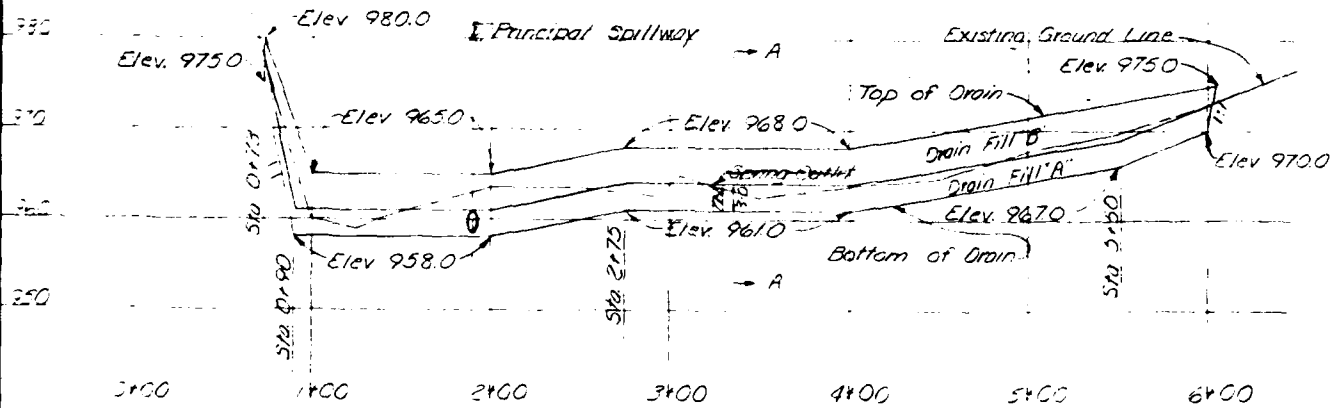

SECTION ON CENTERLINE OF DRAINAGE SYSTEM

NOTES:

1. The outlet width of channel conform depth of gradation
2. Drain Fill gradation
3. Drain Fill gradation
4. The spillway to stop drain system with the dam filled with rock spillway

QUANTITIES ⁶⁶⁵

Drain Fill (Drain Fill 'A' = 295 cu.yd. Drain Fill 'B' = 200 cu.yd.) Total ⁷⁶⁰ 495 Cu Yds
 50' for Outlet (to be excavated from emergency spillway and 20' of rock fill) ¹⁰⁵ 105 Cu Yds

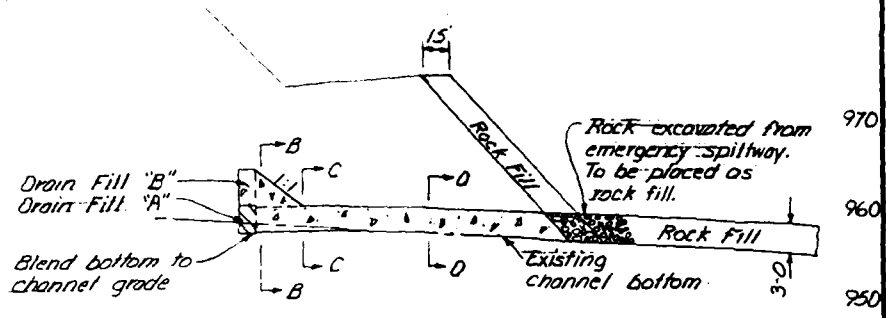
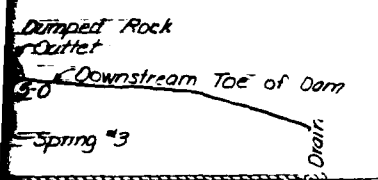

SECTION ON CENTERLINE OF DRAIN OUTLET

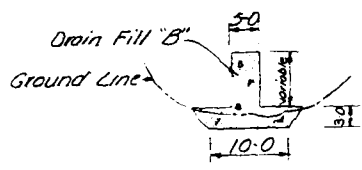

SECTION B-B

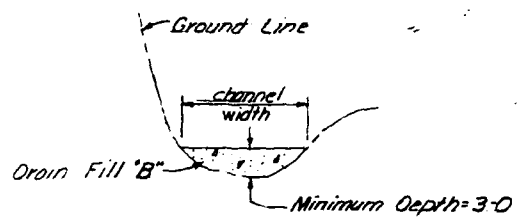

SECTION D-D

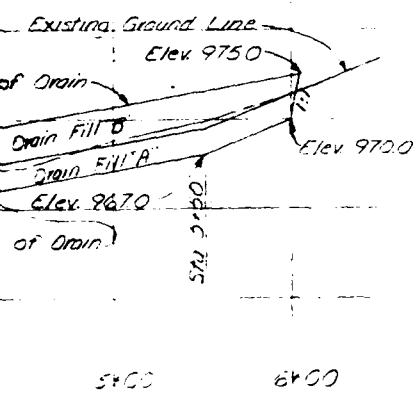

NOTES

- The outlet section shall have a 10' bottom width until the grade blends with the channel bottom. Then the outlet shall conform to the channel shape, have a depth of 3', and be as wide as the channel.
- Drain Fill "A" shall conform to the following gradation:

Sieve Size	Percent Passing
3/8"	100
#4	95 - 100
#16	50 - 95
#50	10 - 30
#100	0 - 10
- Drain Fill "B" shall conform to the following gradation:

Sieve Size	Percent Passing
"	100
3/4"	85 - 100
3/8"	20 - 55
#4	0 - 10
#8	0 - 5
- The springs shall be cleaned out until they flow freely or until the Engineer directs the clearout to stop. Spring #1 will outlet directly into the drain outlet. Spring #2 will be connected to the drain system by a 5'-wide and 3'-deep trench filled with drain fill "B" and outlet to the toe of the dam through a 5'-wide and 3'-deep trench filled with drain fill "B". Approximately 20 cu yd. of rock excavated from the emergency spillway shall be dumped on the toe of the dam as outlet protection for spring #3.

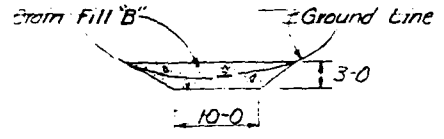

SECTION C-C

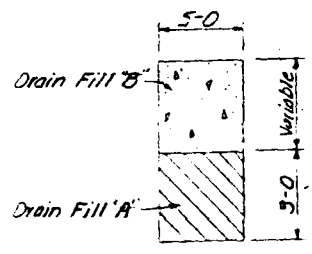

SECTION A-A

760 cu yds
105 cu yds

**STRUCTURE E-1
DRAINAGE SYSTEM
LOST CREEK WATERSHED PL-566
NEWTON COUNTY, MISSOURI**

**U. S. DEPARTMENT OF AGRICULTURE
SOIL CONSERVATION SERVICE**

Des. by M. M. B.	1177
Drawn by J. A. G.	1177
Check by NHR	1177

5E-30314

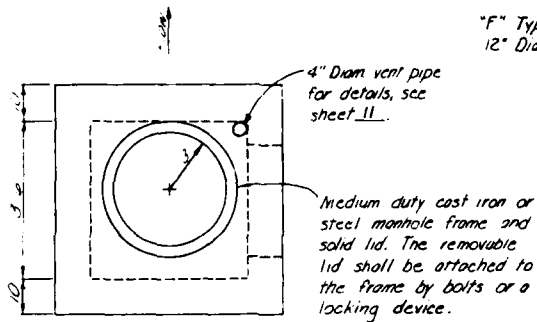

TOP PLAN

"F" Type Wall Thimble
12" Diam.

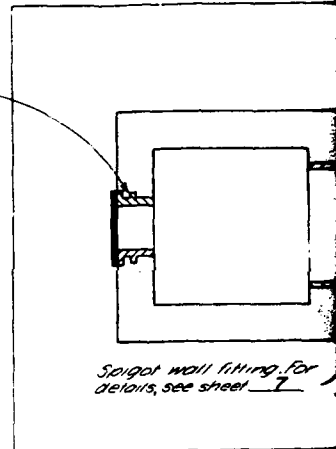

SECTION A-A

NOTES FOR DETAIL OF TRASH RACK AND ANCHORAGE SEE SHEET 12.

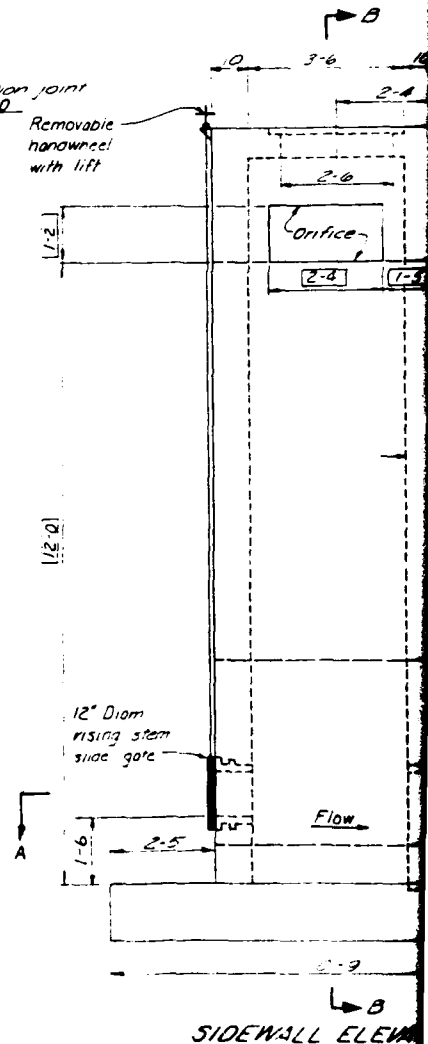
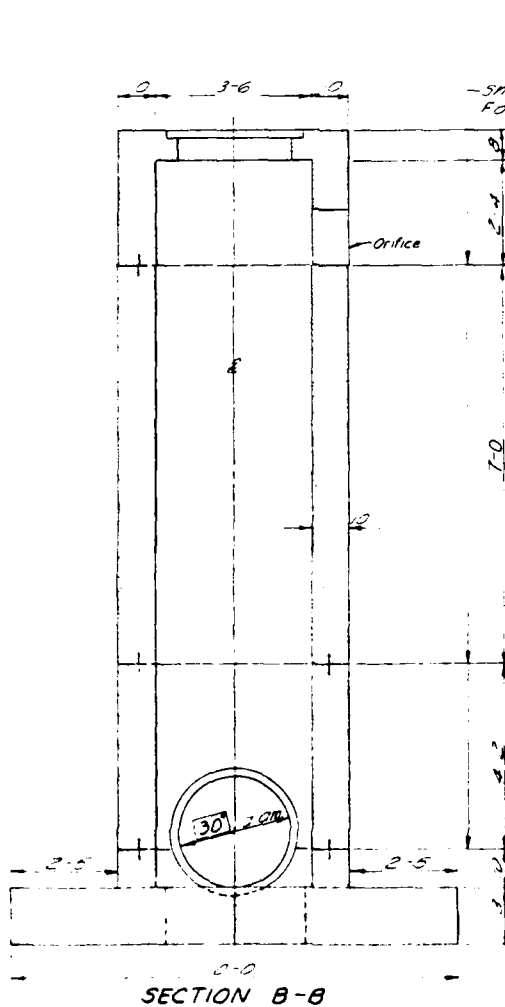

DETAILS OF 3'-6" x 3'-6"
RESTRICTED FLOW RISER
(10' ≤ Height ≤ 15' Sidewall Orifice)

BWP UNIT - DESIGN SECTION
LINCOLN, NE BRASAA

PA 1170 NO. 3, E. 3, 850 227

DATE APPLIED MAY 10, 1971 REV. 3-71

"F" Type Wall Thimble
12" Diam.

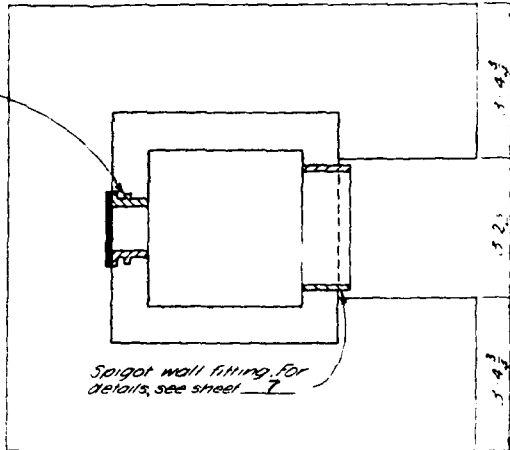

Spigot wall fitting, for details, see sheet 7

SECTION A-A

Note: Modify bedding shown on sheet 7 as required to fit between riser footing bedding and footings shall be separated by 3/4" Bituminous Type pre-formed expansion joint filler.

FOR DETAIL OF TRASH RACK AND ANCHORAGE SEE SHEET 12

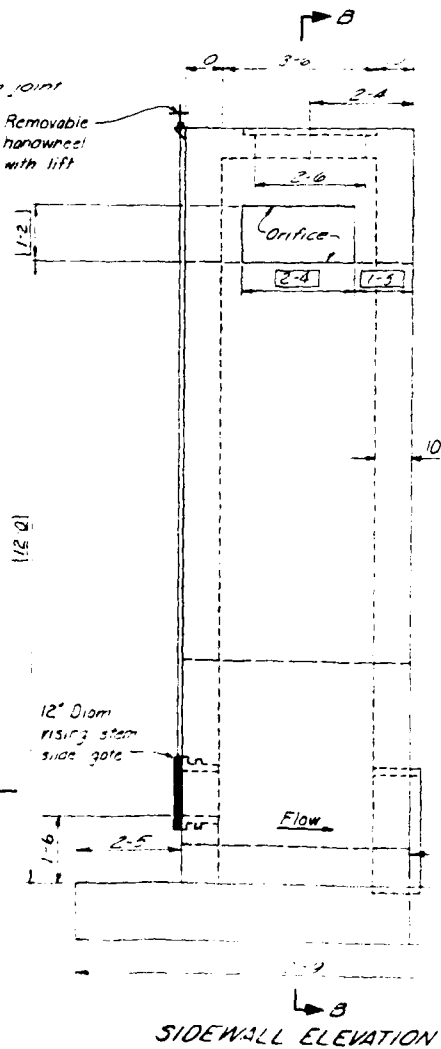

SIDEWALL ELEVATION

BAR BENDS

Straight
TYPE 1

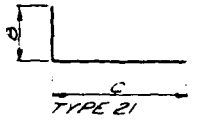

STEEL SCHEDULE

MARK	SIZE	QUANTITY	LENGTH	TOTAL LENGTH	TYPE	B	C
B1	5	9	9-6	85-6	1		
B2	5	8	3-0	24-0	1		
B3	5	8	10-3	82-0	1		
B4	5	5	7-0	35-0	1		
B5	5	9	9-6	85-6	1		
B6	5	8	3-0	24-0	1		
B7	5	8	10-3	82-0	1		
B8	5	11	7-0	77-0	1		
B9	6	12	10-3	123-0	21	3-3	7-0
B10	6	6	7-9	46-6	21	0-9	7-0
B11	4	3	4-0	12-0	1		
B12	4	10	7-6	75-0	21	0-9	6-9
B13	4	6	7-6	45-0	21	0-9	6-9
B14	4	3	4-0	12-0	1		
B15	5	2	4-0	8-0	21	0-9	3-3
B16	5	18	6-6	117-0	21	3-3	3-3
B17	4	21	4-3	89-3	1		
B18	5	4	4-6	18-0	21	1-3	3-3
B19	5	1	2-9	2-9	21	0-9	2-0
B20	4	1	3-9	3-9	1		
B21	6	1	3-9	3-9	1		
B22	6	1	3-0	3-0	21	0-9	2-3
B23	6	1	3-0	3-0	1		
B24	6	1	3-0	3-0	1		
B25	6	1	3-0	3-0	1		
B26	6	1	3-0	3-0	1		
B27	6	1	3-0	3-0	1		
B28	6	1	3-0	3-0	1		
B29	6	1	3-0	3-0	1		
B30	6	1	3-0	3-0	1		
B31	6	1	3-0	3-0	1		
B32	6	1	3-0	3-0	1		
B33	6	1	3-0	3-0	1		
B34	6	1	3-0	3-0	1		
B35	6	1	3-0	3-0	1		
B36	6	1	3-0	3-0	1		
B37	6	1	3-0	3-0	1		
B38	6	1	3-0	3-0	1		
B39	6	1	3-0	3-0	1		
B40	6	1	3-0	3-0	1		
B41	6	1	3-0	3-0	1		
B42	6	1	3-0	3-0	1		
B43	6	1	3-0	3-0	1		
B44	6	1	3-0	3-0	1		
B45	6	1	3-0	3-0	1		
B46	6	1	3-0	3-0	1		
B47	6	1	3-0	3-0	1		
B48	6	1	3-0	3-0	1		
B49	6	1	3-0	3-0	1		
B50	6	1	3-0	3-0	1		
B51	6	1	3-0	3-0	1		
B52	6	1	3-0	3-0	1		
B53	6	1	3-0	3-0	1		
B54	6	1	3-0	3-0	1		
B55	6	1	3-0	3-0	1		
B56	6	1	3-0	3-0	1		
B57	6	1	3-0	3-0	1		
B58	6	1	3-0	3-0	1		
B59	6	1	3-0	3-0	1		
B60	6	1	3-0	3-0	1		
B61	6	1	3-0	3-0	1		
B62	6	1	3-0	3-0	1		
B63	6	1	3-0	3-0	1		
B64	6	1	3-0	3-0	1		
B65	6	1	3-0	3-0	1		
B66	6	1	3-0	3-0	1		
B67	6	1	3-0	3-0	1		
B68	6	1	3-0	3-0	1		
B69	6	1	3-0	3-0	1		
B70	6	1	3-0	3-0	1		
B71	6	1	3-0	3-0	1		
B72	6	1	3-0	3-0	1		
B73	6	1	3-0	3-0	1		
B74	6	1	3-0	3-0	1		
B75	6	1	3-0	3-0	1		
B76	6	1	3-0	3-0	1		
B77	6	1	3-0	3-0	1		
B78	6	1	3-0	3-0	1		
B79	6	1	3-0	3-0	1		
B80	6	1	3-0	3-0	1		
B81	6	1	3-0	3-0	1		
B82	6	1	3-0	3-0	1		
B83	6	1	3-0	3-0	1		
B84	6	1	3-0	3-0	1		
B85	6	1	3-0	3-0	1		
B86	6	1	3-0	3-0	1		
B87	6	1	3-0	3-0	1		
B88	6	1	3-0	3-0	1		
B89	6	1	3-0	3-0	1		
B90	6	1	3-0	3-0	1		
B91	6	1	3-0	3-0	1		
B92	6	1	3-0	3-0	1		
B93	6	1	3-0	3-0	1		
B94	6	1	3-0	3-0	1		
B95	6	1	3-0	3-0	1		
B96	6	1	3-0	3-0	1		
B97	6	1	3-0	3-0	1		
B98	6	1	3-0	3-0	1		
B99	6	1	3-0	3-0	1		
B100	6	1	3-0	3-0	1		
B101	6	1	3-0	3-0	1		
B102	6	1	3-0	3-0	1		
B103	6	1	3-0	3-0	1		
B104	6	1	3-0	3-0	1		
B105	6	1	3-0	3-0	1		
B106	6	1	3-0	3-0	1		
B107	6	1	3-0	3-0	1		
B108	6	1	3-0	3-0	1		
B109	6	1	3-0	3-0	1		
B110	6	1	3-0	3-0	1		
B111	6	1	3-0	3-0	1		
B112	6	1	3-0	3-0	1		
B113	6	1	3-0	3-0	1		
B114	6	1	3-0	3-0	1		
B115	6	1	3-0	3-0	1		
B116	6	1	3-0	3-0	1		
B117	6	1	3-0	3-0	1		
B118	6	1	3-0	3-0	1		
B119	6	1	3-0	3-0	1		
B120	6	1	3-0	3-0	1		
B121	6	1	3-0	3-0	1		
B122	6	1	3-0	3-0	1		
B123	6	1	3-0	3-0	1		
B124	6	1	3-0	3-0	1		
B125	6	1	3-0	3-0	1		
B126	6	1	3-0	3-0	1		
B127	6	1	3-0	3-0	1		
B128	6	1	3-0	3-0	1		
B129	6	1	3-0	3-0	1		
B130	6	1	3-0	3-0	1		
B131	6	1	3-0	3-0	1		
B132	6	1	3-0	3-0	1		
B133	6	1	3-0	3-0	1		
B134	6	1	3-0	3-0	1		
B135	6	1	3-0	3-0	1		
B136	6	1	3-0	3-0	1		
B137	6	1	3-0	3-0	1		
B138	6	1	3-0	3-0	1		
B139	6	1	3-0	3-0	1		
B140	6	1	3-0	3-0	1		
B141	6	1	3-0	3-0	1		
B142	6	1	3-0	3-0	1		
B143	6	1	3-0	3-0	1		
B144	6	1	3-0	3-0	1		
B145	6	1	3-0	3-0	1		
B146	6	1	3-0	3-0	1		
B147	6	1	3-0	3-0	1		
B148	6	1	3-0	3-0	1		
B149	6	1	3-0	3-0	1		
B150	6	1	3-0	3-0	1		
B151	6	1	3-0	3-0	1		
B152	6	1	3-0	3-0	1		
B153	6	1	3-0	3-0	1		
B154	6	1	3-0	3-0	1		
B155	6	1	3-0	3-0	1		
B156	6	1	3-0	3-0	1		
B157	6	1	3-0	3-0	1		
B158	6	1	3-0	3-0	1		
B159	6	1	3-0	3-0	1		
B160	6	1	3-0	3-0	1		
B161	6	1	3-0	3-0	1		
B162	6	1	3-0	3-0	1		
B163	6	1	3-0	3-0	1		
B164	6	1	3-0	3-0	1		
B165	6	1	3-0	3-0	1		
B166	6	1	3-0	3-0	1		
B167	6	1	3-0	3-0	1		
B168	6	1	3-0	3-0	1		
B169	6	1	3-0	3-0	1		
B170	6	1	3-0	3-0	1		
B171	6	1	3-0	3-0	1		
B172	6	1	3-0	3-0	1		
B173	6	1	3-0	3-0	1		
B174	6	1	3-0	3-0	1		
B175	6	1	3-0	3-0	1		
B176	6	1	3-0	3-0	1		
B177	6	1	3-0	3-0	1		
B178	6	1	3-0	3-0	1		
B179	6	1	3-0	3-0	1		
B180	6	1	3-0	3-0	1		
B181	6	1	3-0	3-0	1		
B182	6	1	3-0	3-0	1		
B183	6	1	3-0	3-0	1		
B184	6	1	3-0	3-0	1		
B185	6	1	3-0	3-0	1		
B186	6	1	3-0	3-0	1		
B187	6	1	3-0	3-0	1		
B188	6	1	3-0	3-0	1		
B189	6	1	3-0	3-0	1		
B190	6	1	3-0	3-0	1		
B191	6	1	3-0	3-0	1		
B192	6	1	3-0	3-0	1		
B193	6	1	3-0	3-0	1		
B194	6	1	3-0	3-0	1		
B195	6	1	3-0	3-0	1		
B196	6	1	3-0	3-0	1		
B197	6	1	3-0	3-0	1		
B198	6	1	3-0	3-0	1		
B199	6	1	3-0	3-0	1		
B200	6	1	3-0	3-0	1		
B201	6	1	3-0	3-0	1		
B202	6	1	3-0	3-0	1		
B203	6	1	3-0	3-0	1		
B204	6	1	3-0	3-0	1		
B205	6	1	3-0	3-0	1		
B206	6	1	3-0	3-0	1		
B207	6	1	3-0	3-0	1		
B208	6	1	3-0	3-0	1		
B209	6	1	3-0	3-0	1		
B210	6	1	3-0	3-0	1		
B211	6	1	3-0	3-0	1		
B212</							

STRUCTURE DATA

Class of Structure "C" Floodwater Retarding
 Drainage Area (total) 736 Ac. 1.15 Sq.Mi.
 (uncontrolled) 736 Ac. 1.15 Sq.Mi.
 Time of Concentration 0.8 Hours
 Soil Cover Complex Number 71 For A.M.C. II
 Sediment Capacity Available 57.5 Ac.Ft. below Elev. 975.6
 Total Sediment Capacity Available 60.0 Ac.Ft.
 Capacity Equivalents (Vol.) 0.98 In.
 Retarding Capacity Provided 398.0 Ac.Ft.
 Capacity Equivalents (Vol.) 6.49 In.
 Water Supply Provided None Ac.Ft.-Identify Uses

Freeboard Hyd
 Rainfall
 Runoff
 Peak Infl
 Maximum D
 Maximum W

Principal Spillway:

Maximum Capacity (low stage) 59 c.f.s.
 Maximum Capacity (high stage) — c.f.s.
 10 Day Drawdown Elev. 975.6

Emergency Spillway:

Percent Chance Use 1 Storm Duration 6 Hour
 Type Vegetated Earth "n" Value Used 0.04

Emergency Spillway Hydrograph for Class "C" Structures

Rainfall 12.00 in.
 Runoff 8.19 in.
 Peak Inflow 3,174 c.f.s.
 Maximum Discharge - Emergency Spillway 442 c.f.s.
 Maximum Water Surface Elev. 997.8
 Velocity of Flow (Ve) 7.1 f.p.s.

Supplementar
Special Desi

Supplementary Data and Special Design Features:

Principal Spillway Crest Elev. = 975.6
Emergency Spillway Crest Elev. = 996.2
Emergency Spillway Bottom Width = 100'
Settled Top of Dam Elev. = 1003.2
Height x Storage = 37.2 x 458 = 17,038

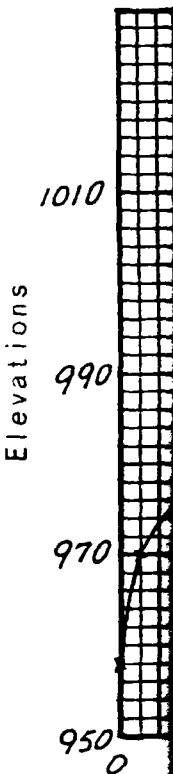

STRUCTURE DATA

Freeboard Hydrograph for Class "C" Structures

.Mi. Rainfall 28.80 in.
 .Mi. Runoff 24.41 in.
 .rs Peak Inflow 9,719 c.f.s.
 . II Maximum Discharge - Emergency Spillway 5,715 c.f.s.
975.6 Maximum Water Surface Elev. 1003.0

Reservoir Capacity

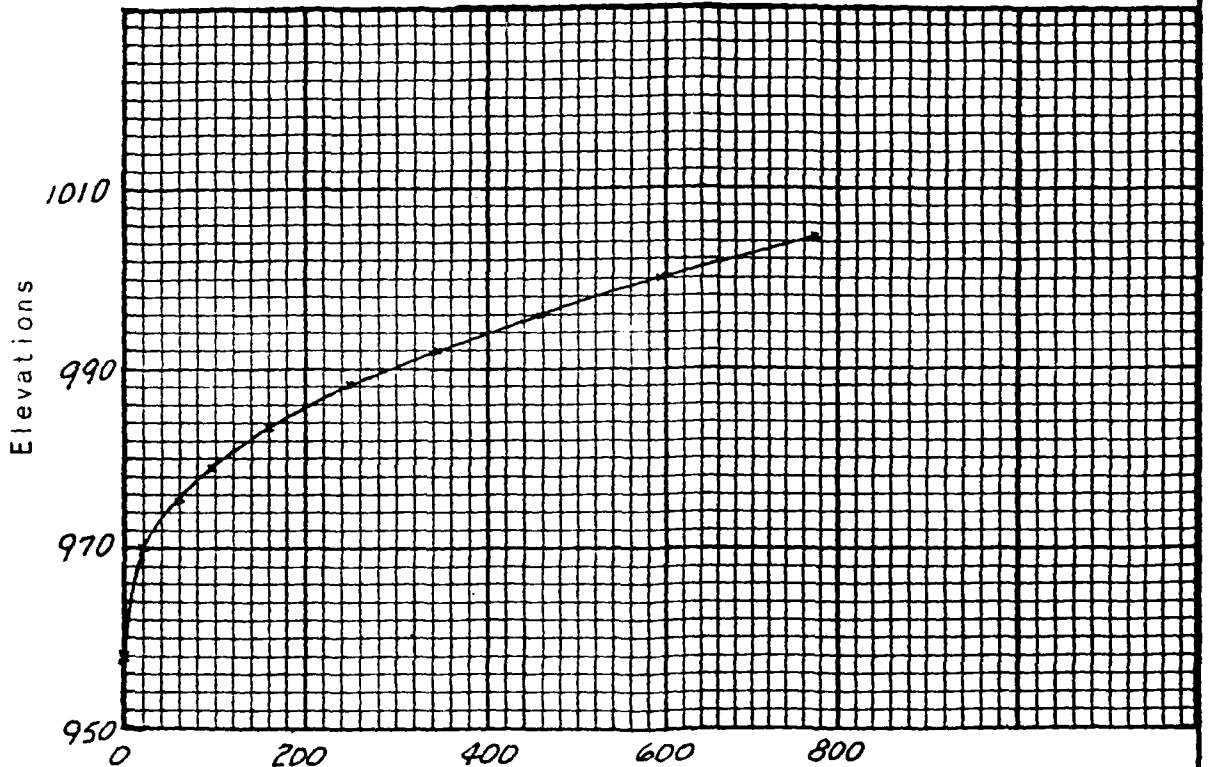

Total Storage - Ac.Ft.

AS BUILT
8-3-79

Supplementary Data and Special Design Features:

STRUCTURE E-1			
LOST CREEK WATERSHED PL-566			
NEWTON COUNTY, MISSOURI			
U. S. DEPARTMENT OF AGRICULTURE			
SOIL CONSERVATION SERVICE			
Designed <u>J.A.G.</u>	Date <u>11-75</u>	Approved by _____	Title _____
Drawn <u>B.E.S.</u>	Date <u>11-76</u>	Checked _____	Title _____
Traced _____	Checked _____	Drawn _____	Title _____
Checked <u>M.M.B. & N.H.R. 12-76</u>	Sheet <u>1</u>	Drawing No. <u>5, E-36,314-H</u>	

1-AS-38a (11/70)
 refer to AS-NO-5
 File Code: AS-12-13

UNITED STATES DEPARTMENT OF AGRICULTURE
 SOIL CONSERVATION SERVICE
 Columbia, Missouri 65201

OPERATION AND MAINTENANCE INSPECTION REPORT
 FOR STRUCTURES

May 14, 1980

Irrigated Just Crack
 Newton County

Structure No. E-1 Inspection:

Special
 Annual

Item	Condition		Describe Main- tenance and Needed Repairs	Esti- mated Costs	Agreed Date Repairs To Be Compl'd	Date Repairs Compl'd
	Satis- factory	Unsatis- factory				
Vegetation		✓	Topdress 14000 with 20-20-10	\$20	9-15-80	
Fences	NA					
Principal Spillway	✓					
Emergency Spillway		✓	Fill hole with Topsoil 10000 and back	\$100.00	9-15-80	
Embankment	✓					
Reservoir Area	✓					
Scour Hole & Outlet Chnl	✓					
Foundation Drains & Relief Wells		✓			9-15-80	
Other Downstream Control		✓		\$50	9-15-80	
Remarks:						
Temporary Diversions		✓		\$200	9-15-80	

Warren H. George
 District Conservationist

Bill H. [unclear]
 Sponsoring Local Organization Rep.

Newton Soil and Water Conservation District
 Sponsoring Local Organization

(Check list on reverse side)

APPENDIX B

Geology and Soils

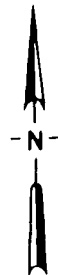

LEGEND

GLACIATED PLAINS 

WESTERN PLAINS 

OZARKS 

ST. FRANCOIS MOUNTAINS 

SOUTHEASTERN LOWLANDS 

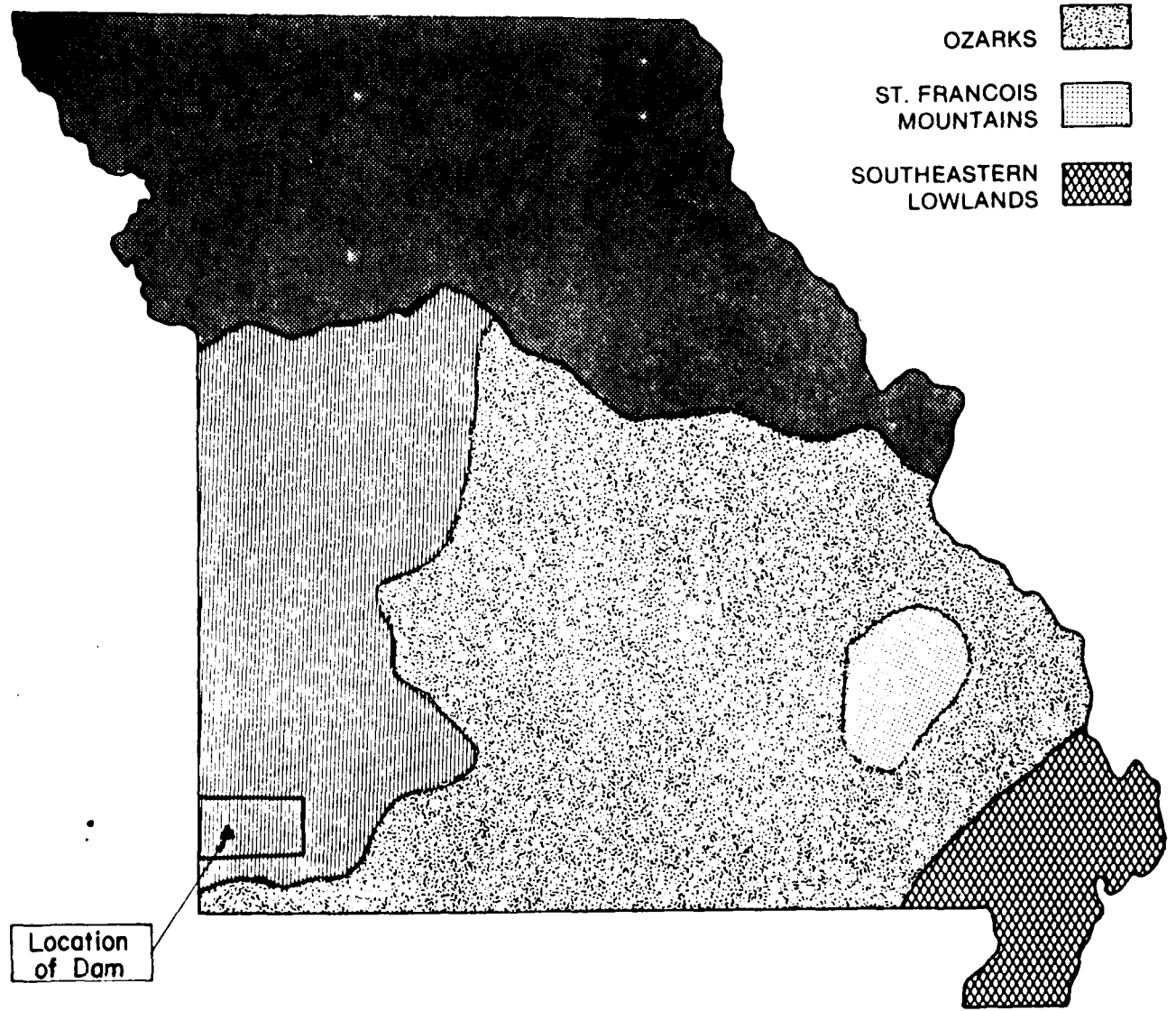

Location of Dam

MAJOR GEOLOGIC REGIONS OF MISSOURI



SPRINGFIELD, IL • PEORIA, IL • ROCKFORD, IL

Newton County Structure E-1
Newton County, Missouri
Mo. I. D. No. 20511

SHEET 1, APPENDIX B

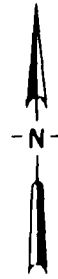

FEET

20 +



10-20



5-10



2.5-5



0-2.5

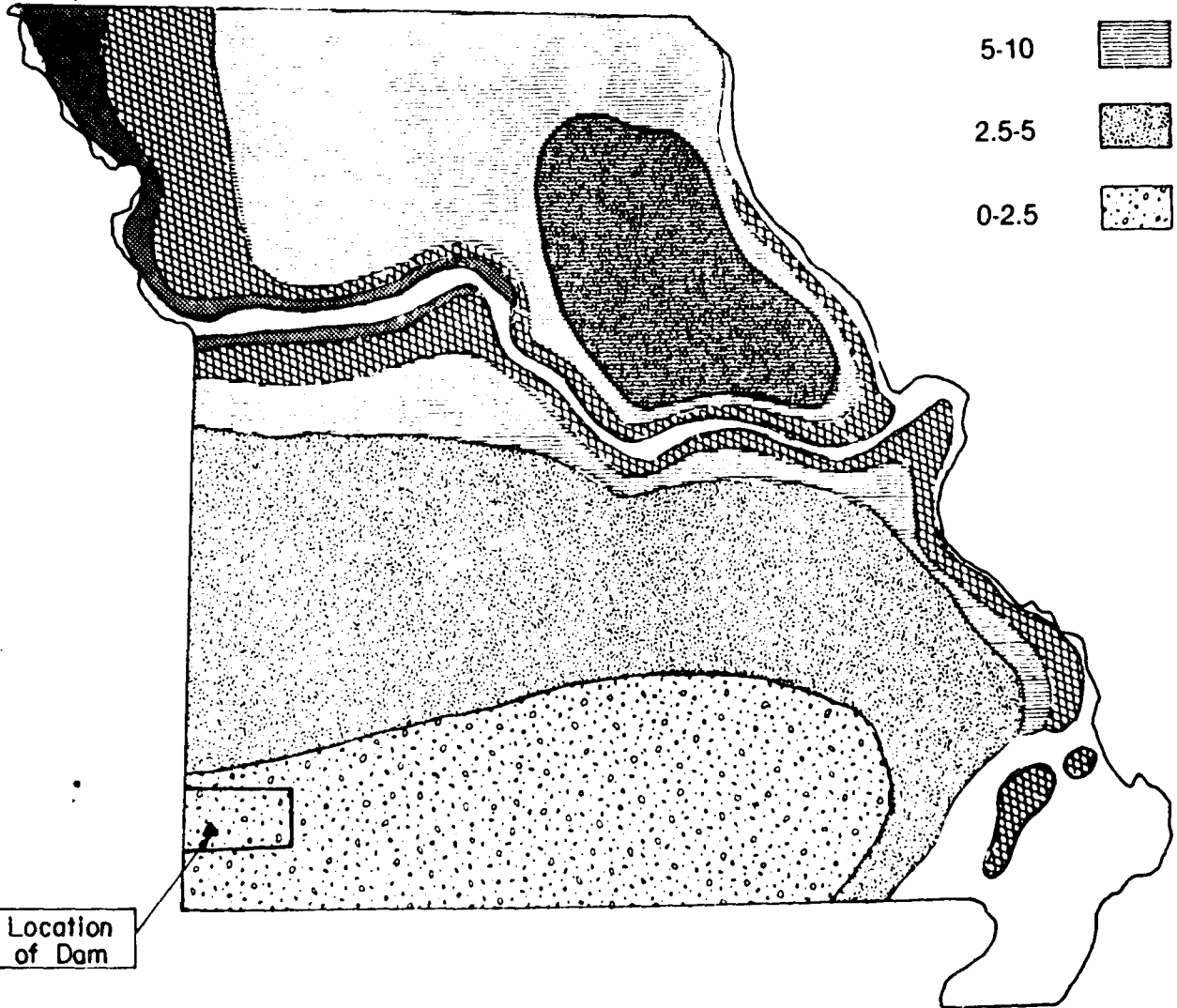

Location of Dam

THICKNESS OF LOESSIAL DEPOSITS



SPRINGFIELD, IL • PEORIA, IL • ROCKFORD, IL

Newton County Structure E-1
Newton County, Missouri
Mo. I. D. No. 20511

SHEET 2, APPENDIX B

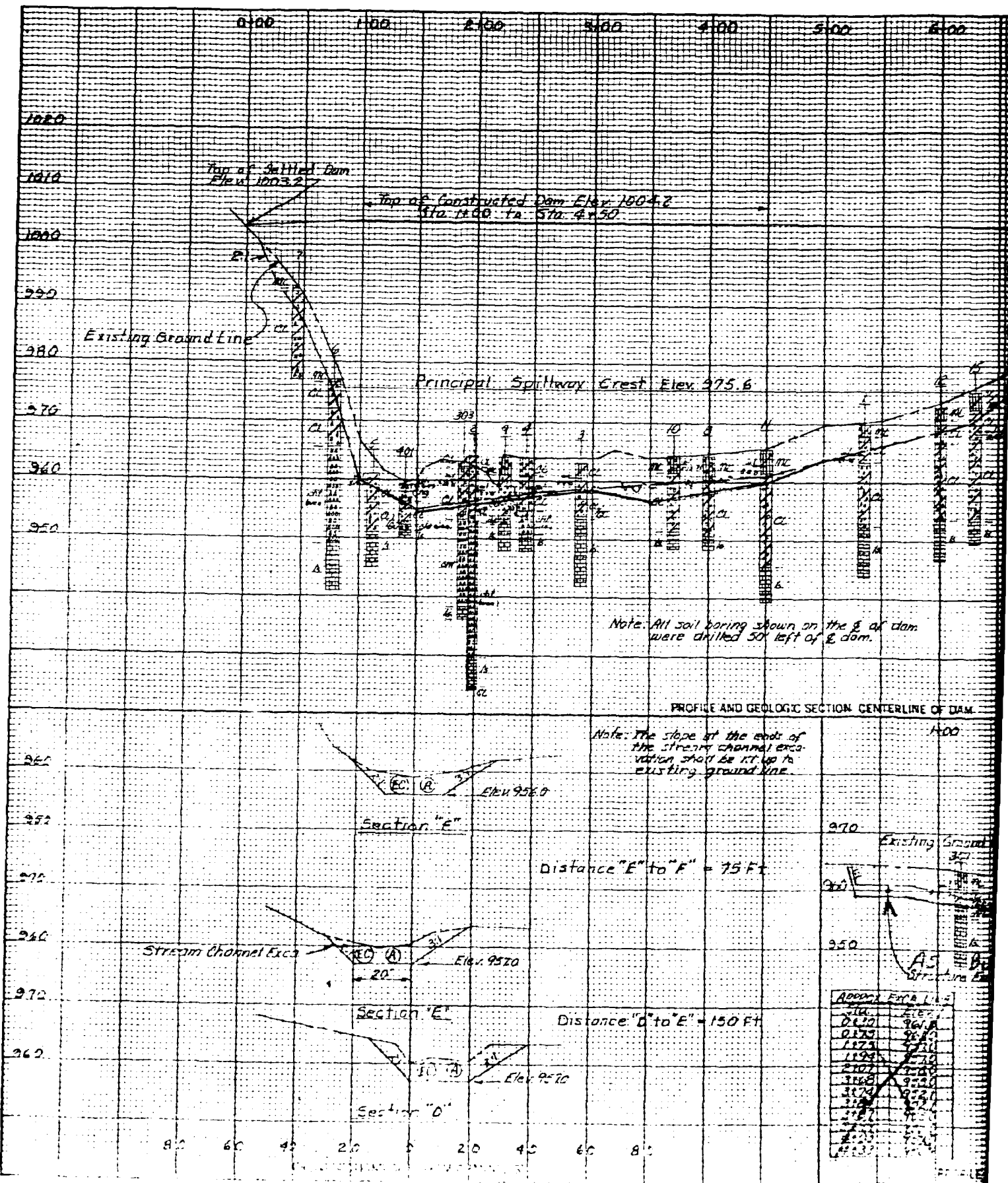

Note: All soil boring shown on the E of dam were drilled 50' left of E of dam.

PROFILE AND GEOLOGIC SECTION, CENTERLINE OF DAM

Note: The slope of the ends of the stream channel excavation shall be 1:1 up to existing ground line.

ADDITIONAL EXCAVATION	
STA.	ELEV.
0+10	961.0
0+20	961.0
0+30	961.0
0+40	961.0
0+50	961.0
1+00	961.0
1+50	961.0
2+00	961.0
2+50	961.0
3+00	961.0
3+50	961.0
4+00	961.0
4+50	961.0
5+00	961.0
5+50	961.0
6+00	961.0

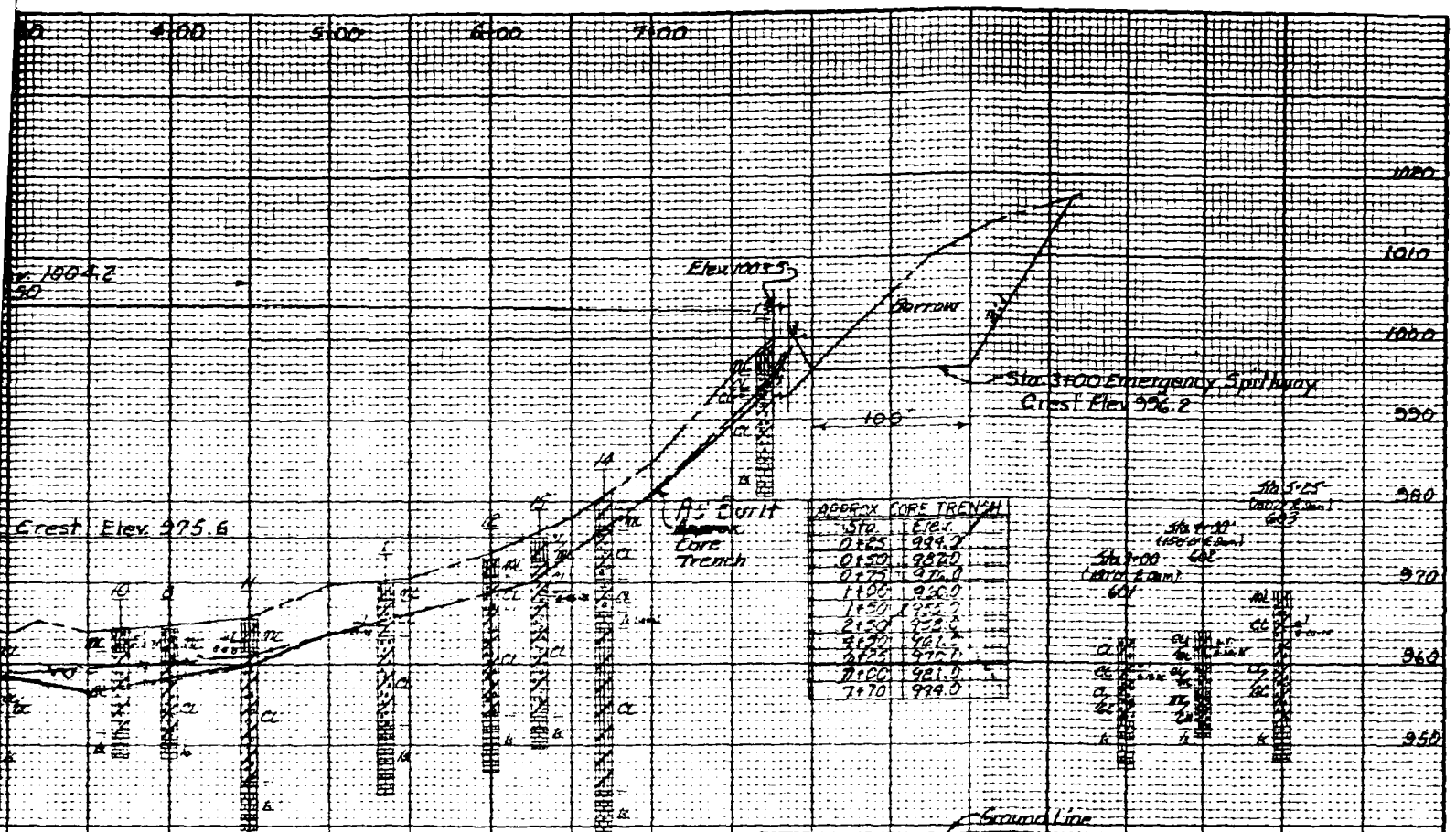

ADDITIONAL CORE TRENCH	
Sta	Elev
510	999.7
0.25	999.0
0.75	998.0
1.25	997.0
1.75	996.0
2.25	995.0
2.75	994.0
3.25	993.0
3.75	992.0
4.25	991.0
4.75	990.0

Note: All soil boring shown on the E of dam were drilled 50' left of E. dam.

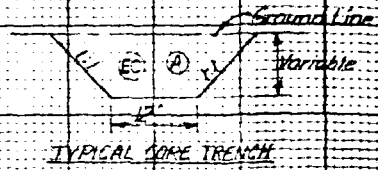

PROFILE AND GEOLOGIC SECTION, CENTERLINE OF DAM.

Note: The slope at the ends of the stream channel excavation shall be set up to existing ground line.

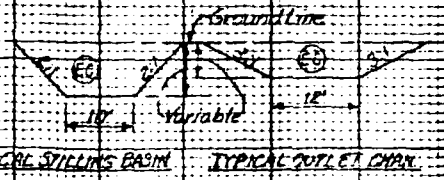
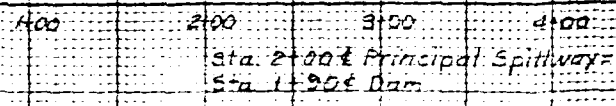

Distance "E" to "F" = 75 Ft

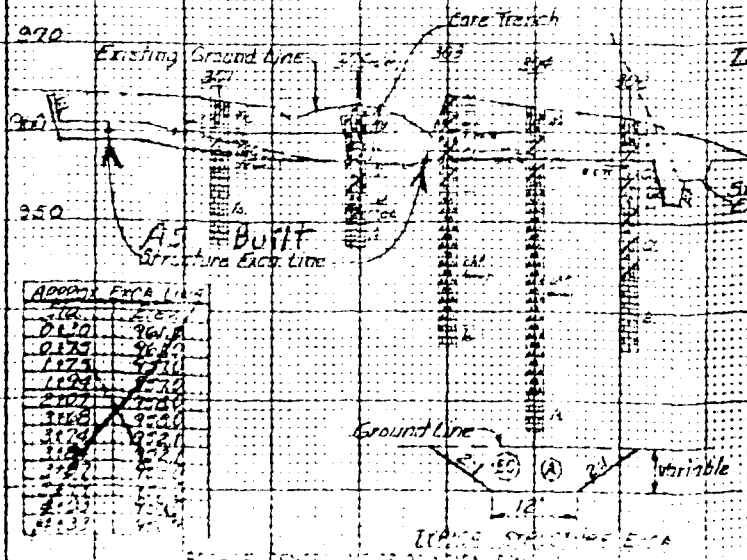

Distance "D" to "E" = 150 Ft

ADDITIONAL EXCA LINE	
Sta	Elev
0.25	999.0
0.75	998.0
1.25	997.0
1.75	996.0
2.25	995.0
2.75	994.0
3.25	993.0
3.75	992.0
4.25	991.0
4.75	990.0

PLAN AND PROFILES FOR GEOLOGIC INVESTIGATIONS
STRUCTURE E-1
 LOST CREEK WATERSHED P.L. 566
 NEWTON COUNTY, MISSOURI
 U. S. DEPARTMENT OF AGRICULTURE
 SOIL CONSERVATION SERVICE

Prepared by: J. R. Lothrop, Geologist, Date: 9-75
 Approved by: B. E. Smith, Date: 9-75
 Eng. No.: 5.E.30.34

ENGINEER'S REPORT
SITE E-1 LOST CREEK

1. STREAM CHANNEL - Stripping and foundation preparation and core trench excavation should eliminate all the stream channel cleanout needed.
2. DEPTH OF CORE - Recommend that the core trench be as shallow as possible to insure a safe dam.
3. UNDESIRABLE MATERIAL - There appears to be no large amount of undesirable material in the foundation area except for a minor concrete structure and silty material located in the spring area downstream from the centerline of the dam.
4. MATERIALS - Excavation from the core and emergency spillway may be used for fill material. Rock was encountered above grade in the upper exit section of the emergency spillway. Sufficient borrow material can be obtained by excavating the top of the hill upstream from the emergency spillway, 2 to 3 feet deep on the right side of the stream channel in the permanent pool area and approximately 6 to 1 slopes along the right abutment from Grid "C" to the emergency spillway.
5. CONDUIT - Due to class of structure the conduit will be reinforced 30 inch concrete pipe. Two locations were drilled out during site investigation and were considered very comparable. Recommend the original location be selected.
6. DRAINAGE - ~~The work plan recommended large bitumastic drains across the floor plate and up the buttresses.~~ Request laboratory recommendations as to the type and locations of drains needed for a safe dam.
7. Recommend that fill placement controls be ~~class C compaction or~~ Class A compaction with controls on the minus 3/4" fraction.

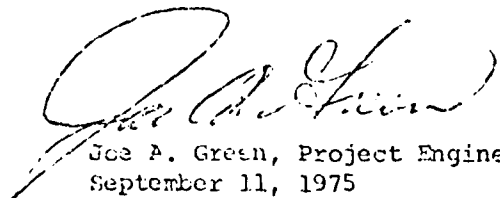
Joe A. Green, Project Engineer
September 11, 1975

Report and Recommendations from the State Design
Engineer and the Engineering Specialist for Soil Mechanics

Site E-1, Lost Creek Watershed
Southwest RC&D, Missouri

The Operations Geologist requested our assistance because of the Tripoli in the foundation and the water supply spring.

The tripoli found in Missouri is a form of weathered chert. This was easily seen when the material was inspected at the site. This formation is not high quality tripoli and is not extensive. It occurs as a pocket under the principal spillway. The material is solid and will not consolidate or weather further. The top few feet are permeable (about 5 fpd) but this will not be a problem from either a construction or stability standpoint. Our conclusion is that the tripoli will not affect the structure and should be treated as ordinary bedrock.

The landowner had the following clause written into the easement he signed. "If within 5 years following the completion of the works of improvement, the flow of the natural spring, located between the fill site and the dwelling location on the farm, is terminated or substantially reduced due to the installation of the works of improvement; a well will be provided by the local organization." This spring seems to be originating in a gravelly pocket which could be an old stream channel. This gravel material contacts the bedrock and lies in a shallow depression in the limestone surface. Two drill holes, one on the C of the dam and one on the C of the drain borings, contacted the gravelly layer. Both of these holes caused the spring to become muddy. No other holes found the gravelly layer or muddied the spring. The water table at this site is quite high, 3 to 4 feet below the ground. We feel that a cutoff to waterline in the CL or GC material will be sufficient on this site. This will leave the gravelly layer intact to feed the spring and the spring may not even be effected by construction activities. The high water table is indicative of a very good chance for a full pool. We walked the stream channel and could find no indication that the stream channel was in any way connected to the aquifer that feeds the spring.

Borrowing should be limited in the pool area to preserve a blanket over the bedrock. The foundation underlying the site is about 12 feet deep across the floodplain. There is 2 to 4 feet of ML over 6 to 8 feet of gravelly, cherty, CL or GC. At the soil-bedrock interface there is a small amount of weathered bedrock. We obtained one undisturbed sample from the lower part of the ML stratum. The CL stratum was just too rocky to sample with a Shelby tube. The foundation appears to be very good with adequate strength for a class c dam.

Foundation drainage will not be required on this site, in fact, a foundation drain may encourage flow under the dam. An embankment drain will probably be needed to meet class c stability requirements.

We are of the opinion that the problems mentioned above are not serious. The other springs mentioned in the geologist report are not hazardous to the dam. The spring upstream from station 3+30 is a wet, marshy area with no open flow. The spring at the base of the left abutment feeds directly into the stream channel and its flow was quite small. An extension of the embankment drain could intercept this flow and outlet in the stream channel below the dam.

The embankment will be a homogeneous fill consisting of gravelly CL from the borrow area on the right abutment. The CL has a rock content which varies between 10 to 40%. The red, waxy CL occurring just above the bedrock should be placed in the interior of the dam, preferably below the phreatic line. There will be ML borrowed from the pool area and placed as a shell section for vegetation.

Neil H. Randall

Neil H. Randall
Head, Design Section

Michael M. Blaine

Michael M. Blaine
Engineering Specialist

10-59

DETAILED GEOLOGIC INVESTIGATION OF DAM SITES

GENERAL

$S\frac{1}{2}$ - 9
 State Missouri County Newton ; N $\frac{1}{2}$ W Sec. 16 , T 25 R 33W ; Watershed Lost Creek
 Subwatershed _____ Fund class WF-08-2018 Site number E-1 Site group I Structure class C
 (FP-2, WP-1, etc.)
 Investigated by _____ Equipment used Failing 1500 RD, DGC Cat. Date 9-9-75
 (signature and title) (type, size, make, model, etc.)

SITE DATA

Drainage area size 1.15 sq. mi., 736 acres. Type of structure Compacted Earth Purpose Floodwater Retarding
 Direction of valley trend (downstream) South Maximum height of fill 44 feet. Length of fill 830 feet.
 Estimated volume of compacted fill required 108,383 yards

STORAGE ALLOCATION

	Volume (ac. ft.)	Surface Area (acres)	Depth at Dam (feet)
Sediment	<u>60</u>	<u>10</u>	<u>17</u>
Floodwater	<u>398</u>	<u>31</u>	<u>37</u>

SURFACE GEOLOGY AND PHYSIOGRAPHY

Physiographic description Ozark Highland Topography Rolling Altitude of beds: Dip SE Strike NE-SW
 Steepness of abutments. Left 37 to 90 percent, Right 27 percent. Width of floodplain at centerline of dam 365 feet
 General geology of site: This site is located upon an outcrop of the Warsaw formation of the
Meramecian series and is Mississippian in age. Bedrock on the site is hardness 4 to 5
cherty limestone, hardness 5 chert and clay and hardness 1 to 2 very weathered tripolitic
chert.
The site is approximately 1/8 mile west and on the upthrown side of the Seneca
fault system. This major fault trends NE and SW in a straight line over an approximate
distance of 8 to 10 miles. Minor faulting is present in the site area, however, no
faulting was apparent under the dam alignment.
Cherty clay and chert is encountered at shallow depths on both abutments overlying
hardness 4-5 limestone. Medium bedded hardness 4 cherty limestone and very weathered
hardness 1-2 tripolitic chert is found at an average depth of 13' to 14' through the
floodplain section.

DETAILED GEOLOGIC INVESTIGATION OF DAM SITES

FEATURE Q Dam

(CENTERLINE OF DAM, PRINCIPAL SPILLWAY, EMERGENCY SPILLWAY, THE STREAM CHANNEL, INVESTIGATIONS FOR DRAINAGE OF STRUCTURE, BORROW AREA, RESERVOIR BASIN, ETC.)

DRILLING PROGRAM

EQUIPMENT USED	NUMBER OF HOLES		NUMBER OF SAMPLES TAKEN		
			UNDISTURBED (STATE TYPE)	DISTURBED	
				LARGE	SMALL
EXPLORATION	SAMPLING				
Failing 1500 RD	15	2	1 (3" Shelby)	--	3
			1 (sack cores)		
TOTAL	15	2	2	--	3

SUMMARY OF FINDINGS
(INCLUDE ONLY FACTUAL DATA)

Soils developed above bedrock in the floodplain areas are a slightly clayey gravelly silt (ML) horizon overlying a gravelly to very gravelly clay (CL) horizon. In some holes, always directly on top of bedrock, a red-waxy slightly gravelly clay horizon was encountered. Average depth of the water level on the Q dam alignment is at an elevation of 960.0 ft. water was flowing in the channel at the time of the site investigation.

The gravel lenses are generally lenticular and discontinuous but some show continuity. In boring #11 at station 4+50 Q dam the gravel zone encountered at 14 to 15 ft. is probably an aquifer for the spring located approximately 260 feet down stream.

Average depth of the water level on the Q dam alignment is at an elevation of 960.0 feet.

Cherty clay and chert is encountered at shallow depths on both abutments, overlying limestone. A permeability test was conducted in boring #6 at station 0+77 Q dam. Permeability rates were moderately low. Circulation was lost in the limestone in three holes #13, #202 and #208 on the right abutment at approximate elevation of 981.0 to 983.0.

Bedded, hardness 4 cherty limestone and very weathered hardness 1-2 tripolitic chert is found at an average depth of 13' to 14' through the floodplain section. Cores were taken of the hardness 1-2 chert in boring #2 and #304. Pressure permeability tests were taken in the very weathered chert in boring #2. Permeability rates were moderately high in the upper portion and decreased with depth.

DETAILED GEOLOGIC INVESTIGATION OF DAM SITES

FEATURE Principal Spillway (1+90 G Dam)

(CENTERLINE OF DAM, PRINCIPAL SPILLWAY, EMERGENCY SPILLWAY, THE STREAM CHANNEL, INVESTIGATIONS FOR DRAINAGE OF STRUCTURE, BORROW AREA, RESERVOIR BASIN, ETC.)

DRILLING PROGRAM

EQUIPMENT USED	NUMBER OF HOLES		NUMBER OF SAMPLES TAKEN		
	EXPLORATION	SAMPLING	UNDISTURBED	DISTURBED	
			(STATE TYPE)	LARGE	SMALL
Falling 1500 RD	5	1	1 sack cores		
TOTAL	5	1	1		

SUMMARY OF FINDINGS
(INCLUDE ONLY FACTUAL DATA)

Hardness 4-5 cherty limestone and or hardness 1-2 very weathered tripolitic chert is at an average depth of 10 feet along this alignment. Boring #302 encountered hardness 4 limestone at 18 feet depth. Very weathered tripolitic chert was encountered in boring #304 at 9 feet to 32 feet depth. Diamond cores were taken of this material in the boring.

Average water table elevation along this alignment is at 959.0 feet.

DETAILED GEOLOGIC INVESTIGATION OF DAM SITES

FEATURE Alternate Principal Spillway (2+60 @ Dam)

(CENTERLINE OF DAM, PRINCIPAL SPILLWAY, EMERGENCY SPILLWAY, THE STREAM CHANNEL, INVESTIGATIONS FOR DRAINAGE OF STRUCTURE, BORROW AREA, RESERVOIR BASIN, ETC.)

DRILLING PROGRAM

EQUIPMENT USED	NUMBER OF HOLES		NUMBER OF SAMPLES TAKEN		
	EXPLORATION	SAMPLING	UNDISTURBED (STATE TYPE)	DISTURBED LARGE	DISTURBED SMALL
<u>Failing 1500 RD</u>	<u>5</u>	<u>1</u>	<u>--</u>	<u>2</u>	<u>-</u>
TOTAL	<u>5</u>	<u>1</u>	<u>--</u>	<u>2</u>	<u>-</u>

SUMMARY OF FINDINGS
(INCLUDE ONLY FACTUAL DATA)

Comparable and similar foundation materials are encountered along this alignment as those discussed in the summary sheet on the original principal spillway @ station 1+90 @ dam.

An estimated additional 250 feet of channel excavation will be necessary if this location is utilized.

Water levels along this alignment varied from an elevation of 961.0 feet to 941.0 feet.

DETAILED GEOLOGIC INVESTIGATION OF DAM SITES

FEATURE Drain Borings

(CENTERLINE OF DAM, PRINCIPAL SPILLWAY, EMERGENCY SPILLWAY, THE STREAM CHANNEL, INVESTIGATIONS FOR DRAINAGE OF STRUCTURE, BORROW AREA, RESERVOIR BASIN, ETC.)

DRILLING PROGRAM

EQUIPMENT USED	NUMBER OF HOLES		NUMBER OF SAMPLES TAKEN		
	EXPLORATION	SAMPLING	UNDISTURBED	DISTURBED	
			(STATE TYPE)	LARGE	SMALL
<u>Failing 1500 RD</u>	<u>3</u>	<u>2</u>	<u>--</u>	<u>--</u>	<u>6</u>
_____	_____	_____	_____	_____	_____
_____	_____	_____	_____	_____	_____
_____	_____	_____	_____	_____	_____
_____	_____	_____	_____	_____	_____
TOTAL	<u>3</u>	<u>2</u>	<u>--</u>	<u>--</u>	<u>6</u>

SUMMARY OF FINDINGS
 (INCLUDE ONLY FACTUAL DATA)

Three (3) drain borings were drilled for correlation and control purposes.
Generally very similar soil materials were found in these borings as those encountered
along the G dam alignment.
Average water table elevation in the drain borings was at 960.0 feet.

DETAILED GEOLOGIC INVESTIGATION OF DAM SITES

FEATURE Springs

(CENTERLINE OF DAM, PRINCIPAL SPILLWAY, EMERGENCY SPILLWAY, THE STREAM CHANNEL, INVESTIGATIONS FOR DRAINAGE OF STRUCTURE, BORROW AREA, RESERVOIR BASIN, ETC.)

DRILLING PROGRAM

EQUIPMENT USED	NUMBER OF HOLES		NUMBER OF SAMPLES TAKEN		
	EXPLORATION	SAMPLING	UNDISTURBED	DISTURBED	
			(STATE TYPE)	LARGE	SMALL
_____	_____	_____	_____	_____	_____
_____	_____	_____	_____	_____	_____
_____	_____	_____	_____	_____	_____
_____	_____	_____	_____	_____	_____
_____	_____	_____	_____	_____	_____
TOTAL	_____	_____	_____	_____	_____

SUMMARY OF FINDINGS
(INCLUDE ONLY FACTUAL DATA)

Numerous springs were present on this site.

The spring located approximately 260 feet downstream from station 4+20 C dam is currently being used for house and garden needs. This spring reportedly has never been dry in the 100 year history of the landowner's family. When boring #11 located at station 4+50 C dam was drilled the spring turned muddy. A clayey gravel zone above bedrock is probably the aquifer for this spring. Water temperature was at 63° F.

The spring in the draw to the right below the dam functions only during wet periods.

A spring is present at approximately 25 feet upstream station 3+30 C dam which has fed a breached shallow pond, below the discharge. The old dam is approximately 100 feet downstream from the spring, about 4 to 5 feet high and according to the landowner was constructed in the year 1869.

A spring was noted at the base of the left abutment approximately 50 feet downstream station 1+00 C dam. Water temperature of this spring was 64° F. at the time of the site investigation.

DETAILED GEOLOGIC INVESTIGATION OF DAM SITES

FEATURE Stream Channel

(CENTERLINE OF DAM, PRINCIPAL SPILLWAY, EMERGENCY SPILLWAY, THE STREAM CHANNEL, INVESTIGATIONS FOR DRAINAGE OF STRUCTURE, BORROW AREA, RESERVOIR BASIN, ETC.)

DRILLING PROGRAM

EQUIPMENT USED	NUMBER OF HOLES		NUMBER OF SAMPLES TAKEN		
	EXPLORATION	SAMPLING	UNDISTURBED	DISTURBED	
			(STATE TYPE)	LARGE	SMALL
<u>Failing 1500 RD</u>	<u>1</u>	<u>--</u>			
TOTAL	<u>1</u>	<u>--</u>	<u>--</u>	<u>--</u>	<u>--</u>

SUMMARY OF FINDINGS
(INCLUDE ONLY FACTUAL DATA)

Sandy cherty gravel was on the surface of the channel and extended to a depth of 3 feet. Underlying the surface gravel, from 3 to 7 feet depth was a gravelly clay (CL). From 7 to 8 feet, weathered chert was encountered on top of limestone bedrock, and cherty limestone was logged at 8 feet depth.

The stream was flowing clear 64° water at the time of the site investigation. The landowner reports the flow as being continuous except during the dry 1934 year the channel was almost dry.

Water was not present in some channel sections upstream as the flow goes underground.

DETAILED GEOLOGIC INVESTIGATION OF DAM SITES

FEATURE Emergency Spillway

(CENTERLINE OF DAM, PRINCIPAL SPILLWAY, EMERGENCY SPILLWAY, THE STREAM CHANNEL, INVESTIGATIONS FOR DRAINAGE OF STRUCTURE, BORROW AREA, RESERVOIR BASIN, ETC.)

DRILLING PROGRAM

EQUIPMENT USED	NUMBER OF HOLES		NUMBER OF SAMPLES TAKEN		
	EXPLORATION	SAMPLING	UNDISTURBED	DISTURBED	
			(STATE TYPE)	LARGE	SMALL
D6C Cat	1	1	--	2	--
Failing 1500 RD	9	1	--	1	--
TOTAL	10	2	--	3	--

SUMMARY OF FINDINGS
(INCLUDE ONLY FACTUAL DATA)

Forebay and Control Section

A thin mantle of cherty silt (ML) overlies a brown-red very cherty clay (CL) horizon. The second horizon extends to an average depth of 4 to 5 feet. Below the brown cherty clay a red waxy tenaceous cherty clay (CL) is encountered. This horizon is less cherty with depth. The red-waxy clay extends to below proposed grade in this area.

Upper Exit Area

Hardness 4-5 cherty limestone bedrock is encountered a few feet above proposed grade in this area.

Boirings #202 and #208 Lost circulation while drilling. However, no measurable voids were encountered.

DETAILED GEOLOGIC INVESTIGATION OF DAM SITES

WATERSHED Lost Creek		SUBWATERSHED		COUNTY Newton	STATE Missouri
SITE NO. E-1	SITE GROUP I	STRUCTURE CLASS C		INVESTIGATED BY: (SIGNATURE OF GEOLOGIST)	DATE 9-9-75

INTERPRETATIONS AND CONCLUSIONS

☒ Dam - The recommended minimum cutoff trench depths should provide an adequate cutoff. The trench will bottom on both abutments in cherty clay and through the floodplain section in gravelly clay material. Some seepage may be expected in the gravelly clay through the floodplain section; and if the cherty limestone is exposed on the right abutment some highly permeable strata may be uncovered. It is not anticipated that the very weathered tripolitic chert material encountered around station 2+00 ☒ dam will constitute any particular stability or construction problem.

Principal Spillway - Location alignment and foundation are satisfactory, and the location at station 1+90 ☒ dam is adequate. Trench depths should eliminate the ML surface material found along this alignment.

Alternate Principal Spillway - This alignment at station 2+60 ☒ dam is not recommended. The foundation along the alignment is comparable to the original alignment and additional channel excavation will be needed.

Drainage - Should be considered from the left to the right abutment.

Stream Channel - 1 to 2 foot removal of the surface gravel at all sections is suggested.

Borrow - Ample materials are available within the suggested borrow limits to construct the dam. More plastic materials are found in the higher elevations; on the right of Emergency Spillway area and on the right flank of Grid "A", "B" and "C". Because of the water table and the advantages of a blanket cover it is suggested that: borrowing be limited in the floodplain areas to a depth of 4 feet or less.

Emergency Spillway - As presently designed an estimated 16,000 cu. yds. of excavation will be needed from the Emergency Spillway area. An estimated 500 cy. yds. of this amount may be rock excavation. The rock excavation was encountered above proposed grade in the upper exit area. Modification of construction design could be considered.

UNITED STATES DEPARTMENT OF AGRICULTURE
SOIL CONSERVATION SERVICE - Soil Mechanics Laboratory
800 "J" Street, Lincoln, Nebraska 68508

SUBJECT: ENG 13-18, Missouri WP-08, Lost Creek, Site E-1
(Newton County) - Supplemental report

DATE: May 11, 1977

TO: James M. Dale
State Conservation Engineer
Soil Conservation Service
Columbia, Missouri

INTRODUCTION

The slope stability analysis of this site was originally reported without considering seismic forces. A telephone call from Mike Blaine was received on May 5, 1977, requesting a seismic evaluation using a 0.05G seismic force.

DISCUSSION

The same shear parameters were used for the analysis as in the previous analysis. This maximum section at Station 1+30 was reported to have a factor of safety of 1.50 with a 50-foot downstream berm and a foundation drain. The 0.05G seismic force applied to this failure condition reduces this factor of safety to 1.32.

The floodplain section at Station 2+65 was reported to have a factor of safety of 1.50 with a 36-foot downstream berm and a drain. This factor will reduce to 1.32 with the same seismic force applied.

Prepared by:

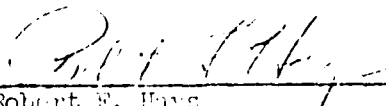
Robert F. Hays
Civil Engineer

Reviewed and Approved by:

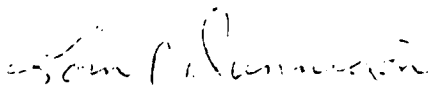
Tom P. Dandigan
Head

cc: Mike Blaine, Columbia
Eugene J. Pope, Lincoln, NE



UNITED STATES DEPARTMENT OF AGRICULTURE
SOIL CONSERVATION SERVICE - Soil Mechanics Laboratory
800 "J" Street, Lincoln, Nebraska 68508

1000-1-2-11-10
RANDALL DR
Koenig
Blair JMB

SUBJECT: ENG 13-18, Missouri WF-08, Lost Creek, Site E-1
(Newton County) - Supplemental Report

DATE: September 27, 1976

TO: James M. Dale
State Conservation Engineer
Soil Conservation Service
Columbia, Missouri

This report supplements our soil engineering report dated February 25, 1976, and is prepared in response to your letter of September 16, 1976.

In your letter you requested additional slope stability analyses based on the following conditions:

1. Phreatic line developed from the crest of the principal spillway (el 975.6) and egressing into a drain located 75 feet downstream from centerline of dam.
2. Use of NAVDOCKS sliding block procedure with conditions per trials No. 13A(down) and 11 (up) in the original analysis.
3. Minimum safety factors as contained in Technical Release 60.

Forms SCS-ENG-357, consisting of three sheets, are attached. They contain the adopted design data and summarize the results of this additional analysis at both the maximum and floodplain sections.

Upstream. The analysis indicates that a $2\frac{1}{2}$:1 slope above and a 3:1 slope below a 15-foot wide berm at elevation 975.6 has an adequate safety factor for the assumed conditions.

Downstream. The analysis indicates that a $2\frac{1}{2}$:1 slope above and below a 14-foot wide berm has an adequate safety factor for the assumed conditions.

- The above embankment cross-section does not consider the design requirements stipulated in EWP Technical Note-ENG-LI-20 (Rev. 1/74) for a hazard class (c) dam located in an earthquake design class 1 region.

Prepared by:

Reviewed and Approved by:

Donald H. Smiberg
Donald H. Smiberg
Civil Engineer

Lorn P. Dunigan
Lorn P. Dunigan
Head

Attachments: Form SCS-ENG-257, Summary - Slope Stability Analysis, 3 sheets
cc: Buell M. Ferguson, Lincoln, NE



UNITED STATES DEPARTMENT OF AGRICULTURE

SOIL CONSERVATION SERVICE - Soil Mechanics Laboratory

800 "J" Street, Lincoln, Nebraska 68508

SUBJECT: ENG 13-18, Missouri WF-08, Lost Creek, Site E-1
(Newton County)

DATE: February 25, 1976

TO: James M. Dale
State Conservation Engineer
Soil Conservation Service
Columbia, Missouri

ATTACHMENTS

1. Form SCS-ENG-354, Soil Mechanics Laboratory Data, 2 sheets
2. Form SCS-ENG-355A & 355B, Triaxial Shear Test Data, 3 tests, 7 sheets
3. Form SCS-ENG-352, Compaction and Penetration Resistance, 2 sheets
4. Form SCS-ENG-357, Summary - Slope Stability Analysis, 6 sheets
5. Figures 1 and 2, 2 sheets

INTRODUCTION

The proposed dam is a hazard class c floodwater retarding structure. It has a maximum height of about 44 feet, a crest length of about 830 feet, and a drainage area of 1.15 square miles.

This site is located in earthquake design class ^C region. The geologic report indicates that there is minor faulting in the area but none at the dam site.

There are several springs at the site as pointed out in the geologic report. Flow in one spring must be maintained per the easement.

DISCUSSION OF DATA

FOUNDATION

A. Bedrock. Bedrock consists of weathered chert overlying limestone. See the geologic report for details. At the centerline of the dam, bedrock lies below the ground surface at depths as follow:

1. Left abutment ≥ 11 feet;
2. Floodplain 10 to 20 feet; and
3. Right abutment 12 to 36 feet.

B. Soil Classification.

1. Left abutment. (Approximate Station 0+00 to 1+00). No samples were submitted. Soil is logged as ML (surface) with underlying CL to the weathered chert.



2. Floodplain. (Approximate Station 1+00 to 4+50). One core and eight bag samples were submitted to the laboratory. The surface materials are logged as ML (2-4 feet thick) or CL, except in the channel where 3 feet of gravel were encountered. Underlying material down to the bedrock is logged as CL and CL/GC, much of which is gravelly to very gravelly.

The surface soils are represented by Samples 76W784A (306-1), 76W78) (601-1), and 76W792 (602-1). Fines vary from 77-100%, LL's from 31-43, and PI's from 11-24. All soils classify as CL's.

The underlying soils are represented by samples as follows:

Sample No.		Depth (ft)	USCS	LL/PI	Fines (%)	Sand (%)	Gravel (%)	Maximum Size (in)
Laboratory	Field							
76W784B	306-2	3-10	GC	41/22	49	23	28	3
785	2-1	4-5.5	CL	36/14	85	12	3	1/2
786	2-2	7-7.5	CL	39/18	72	24	4	3
790	601-2	3-5	GC	37/18	47	19	3/4	1 1/2
791	601-3	5-10	GC	40/20	37	22	4 1/2	1 1/2
793	602-2	4-7	CL	35/16	68	13	19	1 1/2

Except for core sample 76W785, all of the above samples are bag samples.

3. Right Abutment. (Approximate Station 4+50 to 8+30). Samples 76W787 (13-1) and 76W788 (13-2) represent the near surface and underlying soil to bedrock. These samples classify as CH (LL = 70, PI = 41) and CL (LL = 45, PI = 22), respectively. The former has 86% fines and 9% gravel to 1-inch size, whereas the latter has 59% fines and 12% gravel to 1-inch size. Consistency of surface ML's was logged generally as medium, and underlying CL's as stiff.

Laboratory dispersion tests indicate that these samples are not dispersed.

- C. Dry Densities. The dry density of Sample 76W785 (2-1) from core opening was 1.63 g/cc. Dry densities of six shear specimens ranged from 1.53 to 1.65 g/cc. The soils represented by this sample generally have medium to stiff consistency according to the logs.

The surface ML's were not sampled; logs generally describe the consistency as medium.

- D. Permeability and Water Table. No laboratory permeability tests were made. The geologic report states that a field test in TH 6 (left abutment) indicated moderately low permeability values in the 12-36 foot depth interval.

Circulation was lost in TH 13 at elevation 981, TH 202 at elevation 984, and TH 208 at elevation 995--all holes being in the right abutment and emergency spillway area. These losses were at elevations above the permanent pool (el. 975.6). Also, circulation was lost in TH 306 at elevation 938 approximately; this hole is 175 feet downstream from the downstream toe of the embankment.

In the cross section represented by TH 309, 306, 310, 307, and 308 (Station 2+60 \pm dam), the groundwater level ranges from 4 to 6 feet below the ground surface between TH 309 and 307. No groundwater is indicated in TH 308 to a depth of 20 feet at which depth circulation was lost, as pointed out in the preceding paragraph.

In the cross section represented by TH 301, 303, 304, and 302 (Station 1+90 \pm dam), the groundwater level ranges at depths of 4 to 6 feet (el. 961-956).

Groundwater was encountered in the lower portion of the right abutment at elevation 963-968.

The geologist reports four springs at or near the site: one (perennial) about 250 feet downstream from \pm station 4+00; one to the right of the creek downstream (location not given); one 25 feet upstream from \pm station 3+30; and one 50 feet downstream from \pm station 1+00. The geologic report indicates that the aquifer that feeds the perennial spring lies at about elevation 951 in TH 11. Fifteen minutes after drilling TH 11 the water in the spring turned muddy. No communication between other test holes and the spring is indicated in the geologic report.

- E. Consolidation. A consolidation test was not made. The unit consolidation of the lower density portion of Sample 76W785 (2-1) is estimated at about 3.5% and the higher density portion at about 2.5%. These estimates are based on data from the triaxial tests and an embankment load of 5 kaf (40-foot embankment). An s_v -value of 0.4 foot can be used for pipe elongation calculations; this value is based on 11 feet of compressible fine-grained material like Sample 76W785. Actually much of the foundation is logged as gravelly to very gravelly, so data from Sample 76W785 is probably not representative.
- F. Shear Strength. It is impossible to obtain three triaxial shear specimens at the u_{vm} level from a 2 7/8-inch diameter sample. Two tests, as described below, were made on Sample 76W785 (2-1). Both tests were

the consolidated undrained type with measurements of shearing pore pressures. Specimens were 1.4 inch in diameter. Near-saturation was obtained as indicated by the B parameters which ranged from 0.95 to 0.99. See Forms SCS-ENG-355A and -355B attached.

Data from the first test (T-1) were interpreted as follows: total stress $\phi = 14.5^\circ$, $c = 250$ psf; and effective stress $\bar{\phi} = 32^\circ$, $\bar{c} = 175$ psf. Due to variations in specimen dry densities and the total stress Mohr circles, plus the need for wide berms as discussed in the slope stability section, a second test was made.

Data from the second test (T-2) were interpreted as follows: total stress $\phi = 16^\circ$, $c = 800$ psf; and effective stress $\bar{\phi} = 32^\circ$, $\bar{c} = 175$ psf. Total stress shear parameters in test T-2 are higher, especially cohesion, than values in test T-1. However, effective stress shear parameters are the same in both tests.

The six total stress Mohr Circles from the two tests are plotted on Form SCS-ENG-355A marked "Composite T-1 and T-2." The Mohr envelope for four circles indicates $\phi = 18^\circ$, $c = 725$ psf with specimen dry densities ranging from 1.59-1.65 g/cc. The Mohr envelope for the other two circles indicates $\phi = 14.5^\circ$, $c = 250$ psf with specimen dry densities of 1.53 and 1.54 g/cc.

Thus, these tests appear to indicate a range in CU shear strength for lower and higher dry densities or for different materials.

EMBANKMENT

- A. Classification. Five large-bag samples were received. Large-bag sample 104-2, 7-13 foot depth, was not received. Borrow will be obtained from the emergency spillway excavation and uphill from it, floodplain in pool area, and upstream side of right abutment in pool area. No quantities were given. See Form SCS-ENG-354 and Figure 1 for gradation and Atterberg limits information.

Emergency spillway materials are represented by Samples 76W794 (201-1) and 76W795 (201-2). These samples classify as GP-GM and GC, have PI's of 5 and 24, contain 14% and 25% cobbles, and have 44% and 41% finer than the 3/4-inch sieve, respectively. Sample 76W794 (201-1) has only 7% fines. These samples did not contain the waxy red clay as was indicated in logs of some of the other test holes in the emergency spillway.

Floodplain materials are represented by Samples 76W796 (101-2) and 76W797 (101-3). They classify as SC and CH, have PI's of 16 and 32, have 40% and 53% fines, and have 94% and 98% finer than the 3/4-inch sieve, respectively. Sample 76W797 almost classifies as a SC or GC and may contain some waxy red clay since the fines are highly plastic. Groundwater at the time of investigation was about 5-7 feet below the ground surface.

Upstream right abutment materials are represented by Sample 76W798 (104-1). It classifies as a CL (almost a SC), has a PI of 16, 51% fines, and 100% finer than the 3/4-inch sieve.

The three samples from the pool area are considerably finer than the emergency spillway samples. (See Figure 1.) The spillway samples contain from 56-59% sizes, including cobbles, larger than the 3/4-inch sieve.

- B. Compacted Moisture-Density and Relative Density. Two compaction tests (ASTM D-698) and one relative density test were performed. See attached Forms SCS-ENG-352 for compaction test results. The relative density test was made due to the small amount of fines in 76W794 and inability to perform a standard compaction test. A summary of test and field data follows:

Sample No.		Sample Depth (ft)	Std. Compaction (D-698)				Relative Density	
			Fraction Tested	Method	Max. γ_d (pcf)	w_p (%)	Min. γ_d (pcf)	Max. γ_d (pcf)
Laboratory	Field							
76W-794	201-1	0.5-4.5	-1 1/2"	--	--	--	83.1	109.4
796	101-2	3-8	-3/4"	C	112.5	14.0	--	--
798	104-1	2-7	-#4	A	111.0	16.0	--	--

The moisture-density curve for Sample 76W796 peaks abruptly, indicating relatively narrow moisture limits for compaction control.

Bulk dry densities of plus No. 4 materials in the preceding table varied from 128.5 to 136.7 pcf. Absorption of the same fractions varied from 5.7% to 9.3%. See attached Forms SCS-ENG-354.

- C. Permeability and Consolidation. No tests were performed. Permeability of materials like 76W796 through 798 should be low at densities $\geq 95\%$ ASTM D-698. Using data from the triaxial shear test on 76W796, unit consolidation of the embankment materials at maximum fill height, compacted to 95% or more ASTM D-698, is estimated at 0.01 ft. ft.
- D. Shear Strength. A consolidated undrained triaxial test with measurement of shearing pore pressures was made on the minus No. 4 fraction of Sample 76W796 (101-2). Specimens were 1.4 inch in diameter; they were compacted to 95% of ASTM D-698 at molding moisture of 17.8%. See Forms SCS-ENG-355A and -355B attached. The B parameters of 0.94 to 0.98 indicate that near saturation was obtained by backpressuring. Shear parameters as follows were interpreted from test results: total stress $\phi = 14^\circ$, $c = 1,125$ psf; effective stress $\bar{c} = 29^\circ$, $\bar{c} = 475$ psf.

SLOPE STABILITY ANALYSES

Slope stability analyses were made at two sections: maximum $\frac{1}{2}$ station 1+30 and floodplain $\frac{1}{2}$ station 2+65. Two circular arc and one sliding block procedures were used--the latter because the thickness of foundation soil is relatively thin. Two sets of foundation shear parameters, as discussed under "foundation shear strength," were used. See attached Forms SCS-ENG-357 for a summary. A discussion of the results follows:

1. Maximum Section (Station 1+30 $\frac{1}{2}$ dam).

a. Shear parameters (foundation $\phi = 14.5^\circ$, $c = 250$ psf; embankment $\phi = 29^\circ$, $\bar{c} = 475$ psf).

(1) Upstream slope: full drawdown from elevation 996.2. Requires 60-foot berm at elevation 975.6 with 3:1 slope below berm and $2\frac{1}{2}$:1 slope above to obtain a safety factor of 1.35. (See trial No. 12 on summary form 357.)

(2) Downstream slope: steady seepage from elevation 996.2 and drain at $e = 0.6$ b. Requires 50-foot berm at elevation 973.3 with $2\frac{1}{2}$:1 slopes above and below the berm to obtain a safety factor of 1.50. (See trial No. 15.)

b. Shear parameters (foundation $\phi = 18^\circ$, $c = 725$ psf; embankment $\phi = 29^\circ$, $\bar{c} = 475$ psf).

(1) Upstream slope: full drawdown from elevation 996.2. Requires 15-foot berm at elevation 975.6 with $2\frac{1}{2}$:1 side slopes above and below the berm. (See trial No. 11A.)

(2) Downstream slope: steady seepage from elevation 996.2 and drain at $e = 0.6$ b. Requires 10-foot berm at elevation 973.3 with $2\frac{1}{2}$:1 side slopes above and below the berm. (See trial No. 13B.)

2. Floodplain Section (Station 2+65 $\frac{1}{2}$ dam).

a. Shear parameters (foundation $\phi = 14.5^\circ$, $c = 250$ psf; embankment $\phi = 29^\circ$, $\bar{c} = 475$ psf).

(1) Upstream slope: full drawdown from elevation 996.2. Requires 30-foot berm at elevation 975.6 with 3:1 slope below berm and $2\frac{1}{2}$:1 slope above the berm to obtain a safety factor of 1.35. (See trial No. 17.)

(2) Downstream slope: steady seepage from elevation 996.2 and drain at $c = 0.6 b$. Requires 35-foot berm at elevation 973.3 with $2\frac{1}{2}:1$ side slopes above and below the berm. (See trial No. 20.)

b. Shear parameters: (foundation $\phi = 18^\circ$, $c = 725$ psf; embankment $\phi = 29^\circ$, $\bar{c} = 475$ psf).

No analyses were run, but safety factors will be adequate in view of the analyses in paragraph 1 b (1) and 1 b (2) above.

The low shear strength in the foundation (triaxial test T-1) necessitates (1) wider upstream and downstream berms, and (2) flattening of the upstream slope below the berm in comparison with the values proposed on Form SCS-356.

SEEPAGE ANALYSIS

Due to lack of sufficient data, a seepage analysis has not been made. Nothing was given in the geologic report on origin of foundation soils, but we assume that some alluvial material is present along with the residual soils. Logs indicate zones of very gravelly soil but do not indicate whether clean or highly permeable layers of sand gravel exist. It is not unreasonable, particularly if some soils are alluvial, that highly permeable layers exist. The perennial spring is evidence that somewhere in the foundation there is a continuous layer(s) of relatively high permeability beneath the proposed dam.

If a highly permeable layer(s) occurs at a relatively shallow depth in the foundation or abutments, the reservoir head could cause high uplift pressure beneath the ML/CL blanket at or near the downstream toe of the embankment. For example, a low factor of safety against heaving at the toe is indicated when the following assumptions are made: head = 33 feet; blanket thickness = 10 feet; aquifer thickness = 2 feet; aquifer to blanket permeability ratio = 1,000; and buoyant blanket. These are reasonable assumptions.

SETTLEMENT ANALYSIS

A settlement analysis was not made due to lack of sufficient data.

CONCLUSIONS AND RECOMMENDATIONS

A. Site Preparation. It is suggested that (1) the gravel and other highly permeable material in the present channel be removed from the cutoff to the upstream toe, and (2) the steep slope in the lower portion of the left abutment be flattened to 1:1 or flatter. Normal stripping operations should remove undesirable material from the marshy area just upstream from Station 3+00 $\frac{1}{2}$ dam.

- B. Cutoff. A partial cutoff through the surface ML and CL above the water table in the floodplain is probably adequate, as recommended in the engineer's report. This should not interfere with the downstream spring. We are not sure what effect, if any, the added weight of the dam and potential reduction in permeability of the aquifer will have on flow to this spring. Due to the shallow cutoff, lack of foundation drain, and gravelly seams in the foundation, wet spots may develop in the floodplain downstream from the dam when the reservoir level is raised. We do not know what bearing this may have on the buildings immediately downstream from the dam. A shallow cutoff in the abutments through the ML into the CL should be adequate.
- C. Drainage. An embankment drain is needed for slope stability. It is suggested that this drain be located at $c = 0.6 b$. It need not extend into the foundation. The volume of surface material like Sample 76W794 (201-1) is not known. It appears that material like this sample can be used for the drain. Surface foundation materials like Sample 76W734A (306-1) have intermediate PI values, so a filter such as fine aggregate ASTM C-33 should be placed between the drain material and the foundation material. See the sketch in the upper left-hand corner of Figure 2. The borrow materials (other than 76W784A) have PI values greater than 25. A filter is not needed between the embankment and the drain material under these circumstances. The drain should extend up the abutments to about elevation 975.
- As suggested in the engineer's report, the spring about 50 feet downstream from Station 1+00 & dam can be connected to the embankment drain.
- D. Principal Spillway. The location of the principal spillway normal to Station 1+90 & dam appears to be satisfactory. The bedrock drops off considerably below the lower half of the downstream slope, but the embankment load is decreasing, so undesirable settlement may not be a problem. With the invert at the outlet end at elevation 961.2, it appears that little excavation after normal stripping will be required. Horizontal strain is estimated at about 0.003 ft/ft. A ϕ value of 30° is suggested for pipe loading calculations. Fill and backfill around the pipe can consist of material like 76W758 (104-1) compacted to 95% of standard at a moisture content of optimum or greater.
- E. Embankment Design. Volumes of the various borrow materials are not known. The water table in the floodplain is relatively high, thus limiting depth of borrow. We concur with the engineer's suggestion that a soil blanket be left over the bedrock, perhaps 3-4 feet minimum thickness. No formal zoning of the embankment is proposed.

1. Placement of Materials. High-plasticity soils should be placed in the lower portion of the center of the embankment and in the interior upstream portion of the embankment. Placement of the waxy red clay in the low center of the fill may be a problem since it is generally located at some depth in the borrow profiles. Materials like Samples 76W796, 797, and 798 can be placed in the center or upstream portion of the embankment.

Material like 76W794 (201-1), if not used in the drain, can be placed in a downstream toe section. Material like 76W795 can be placed in the lower portion of the downstream section above and upstream of 76W794 or, if enough material is available, in the entire downstream section.

Fill density of material like 76W794 (201-1) and 76W795 (201-2) can be controlled by a method specification. Control of fill density of materials like 76W796 (101-2), 76W797 (101-3), and 76W798 (104-1) can be on the minus 3/4-inch or minus No. 4 fraction per ASTM D-696, Methods C or A, respectively. Placement moisture content should be optimum or higher.

2. Slopes and Berms. It is doubtful that weak materials, as indicated by triaxial test T-1 (the lower portion of core 76W798, 2-1), can be differentiated in the field. Thus, weak materials probably cannot be removed with any degree of certainty. Two alternatives, based on present sampling and laboratory testing, are proposed.

Alternate No. 1. Assuming the weak foundation material is not removed, the following embankment cross section is suggested: upstream--60-foot wide berm at elevation 975.6 with 3:1 slope below the berm and 2 1/2:1 slope above; downstream--50-foot wide berm at elevation 973.3 with 2 1/2:1 slopes above and below the berm and an embankment drain at $c = 0.6 b$. The maximum section is only about 50 feet long at centerline of dam. A 50-foot upstream and a 35-foot downstream berm provide safety factors of 1.21 and 1.42, respectively; these berms provide adequate safety factors of 1.35 and 1.50 in the floodplain section. The width of the berms could be varied, i.e. use a greater width in the maximum section and a lesser width in the floodplain section. Using the weaker foundation strength in the analyses may seem conservative in view of the possibly stronger gravelly and very gravelly material in the lower portion of the clay stratum; however, it only takes a thin layer of weak material to provide a plane for sliding.

Alternate No. 2. Assuming that the weak foundation material is removed, the following embankment cross section is suggested: 15-foot upstream berm at elevation 975.6, 10-foot downstream

berm at elevation 973.3, $2\frac{1}{2}$:1 slopes both sides, and an embankment drain beneath the downstream slope at $c = 0.6 b$. This is the cross section proposed on Form SCS-356.

Another alternative is to do more sampling of the foundation soils and testing of undisturbed samples in an effort to delineate weak materials.

3. Overfill. An overfill allowance of one foot between \pm Station 1+00 and 4+50 is suggested to compensate for residual settlement after completion of the embankment.

Prepared by:

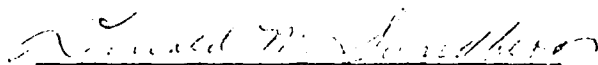
Donald M. Sunilberg
Civil Engineer

Reviewed and Approved by:

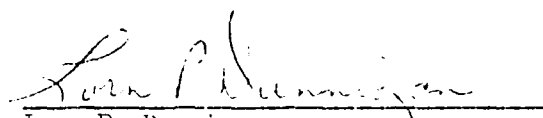
Iorn P. Dummigan
Head

Attachments

cc:

Joe A. Green, Mt. Vernon (2)
Buell M. Ferguson, Lincoln, NE

MATERIALS TESTING REPORT U.S. DEPARTMENT of AGRICULTURE SOIL CONSERVATION SERVICE **TRIAxIAL SHEAR TEST**

PROJECT and STATE: East Creek Site E-1, MISSOURI SAMPLE LOCATION: E 0041, 1498 ft. NW

FIELD SAMPLE NO: 2-1 DEPTH: 4-5.5' GEOLOGIC ORIGIN:

TYPE OF SAMPLE: undisturbed TESTED AT: SMU - Lincoln APPROVED BY: DATE:

INDEX TEST DATA			SPECIMEN DATA		TYPE OF TEST	
USCS	<u>CL</u>	; LL <u>36</u> ; PI <u>14</u>	HEIGHT	<u>3.0</u> "	DIAMETER	<u>1.2</u> "
% FINER (mm): 0.002 _____ ; 0.005 _____ ; 0.074 (# 200) _____			MATERIALS TESTED PASSED		<u>20</u> SIEVE	UU <input type="checkbox"/>
G _s (#4) <u>2.62</u> ; G _s (#4) _____			METHOD OF PREPARATION		<u>Trimmed</u>	CU <input type="checkbox"/>
STANDARD: γ _d MAX. _____ pcf; w ₀ _____ %			MOLDING MOISTURE		_____ %	CU <input checked="" type="checkbox"/>
MODIFIED: γ _d MAX. _____ pcf; w ₀ _____ %			MOLDED AT		_____ % OF γ _d MAXIMUM	CD <input type="checkbox"/>

DRY DENSITY		P _r , psf	MOISTURE CONTENT, %			TIME OF CONSOLIDATION (hrs)	MINOR PRINCIPAL STRESS σ ₃ (psi)	DEVIATOR STRESS σ ₁ - σ ₃ (psi)	AXIAL STRAIN AT FAILURE, ε (%)
INITIAL pcf <input type="checkbox"/> g/cc <input checked="" type="checkbox"/>	CONSOLIDATED pcf <input type="checkbox"/> g/cc <input type="checkbox"/>		START OF TEST	DEG. OF SAT. AT START OF TEST	END OF TEST				
<u>1.53</u>		<u>0.96</u>			<u>26.7</u>	<u>12.17</u>	<u>10</u>	<u>11.1</u>	<u>4.0</u>
<u>1.54</u>		<u>0.96</u>			<u>25.0</u>	<u>15.08</u>	<u>35</u>	<u>31.0</u>	<u>2.0</u>
<u>1.60</u>		<u>0.96</u>			<u>22.4</u>	<u>16.52</u>	<u>40</u>	<u>49.0</u>	<u>7.0</u>

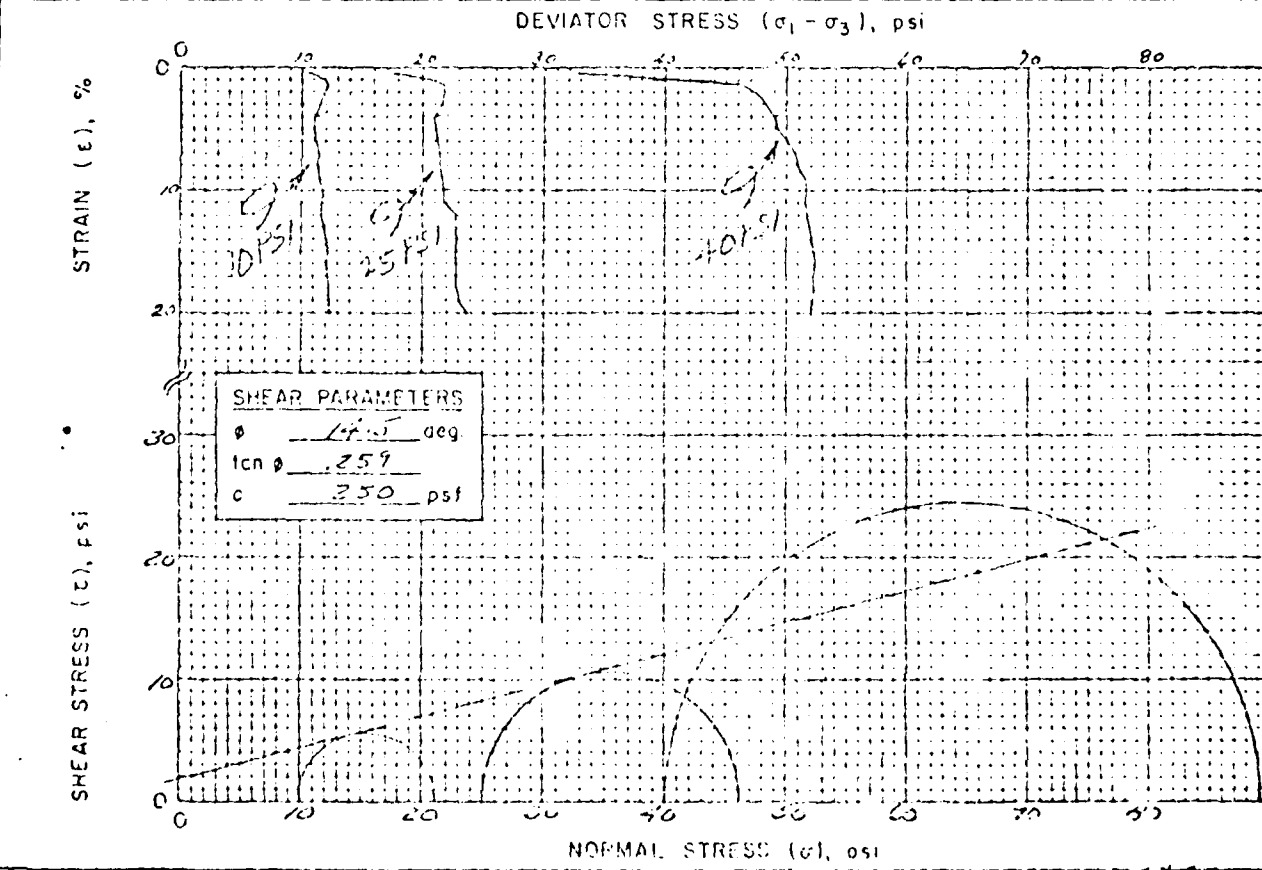

REMARKS: BACK-PRESSURED

MATERIALS TESTING REPORT U. S. DEPARTMENT OF AGRICULTURE SOIL CONSERVATION SERVICE **TRIAxIAL SHEAR TEST** with pore pressure measured

PROJECT AND STATE: *ROAD SITE E-1, MISSOURI* SAMPLE LOCATION: *RD. 1498 & DAM*

TYPE OF SAMPLE: *CLAY* TESTED AT: *Soil - Lincoln* APPROVED BY: _____ DATE: _____

MINOR PRINCIPAL STRESS, σ_3 (psi)	PORE PRESSURE, u (psi)	EFFECTIVE MINOR PRINCIPAL STRESS, $\bar{\sigma}_3$ (psi)	DEVIATOR STRESS, $\sigma_1 - \sigma_3$ (psi)	FAILURE CRITERIA	AXIAL STRAIN AT FAILURE, ϵ (%)
10	7.0	3.0	11.1		4.0
25	16.9	8.1	21.0		4.0
40	21.9	18.1	49.0		4.0

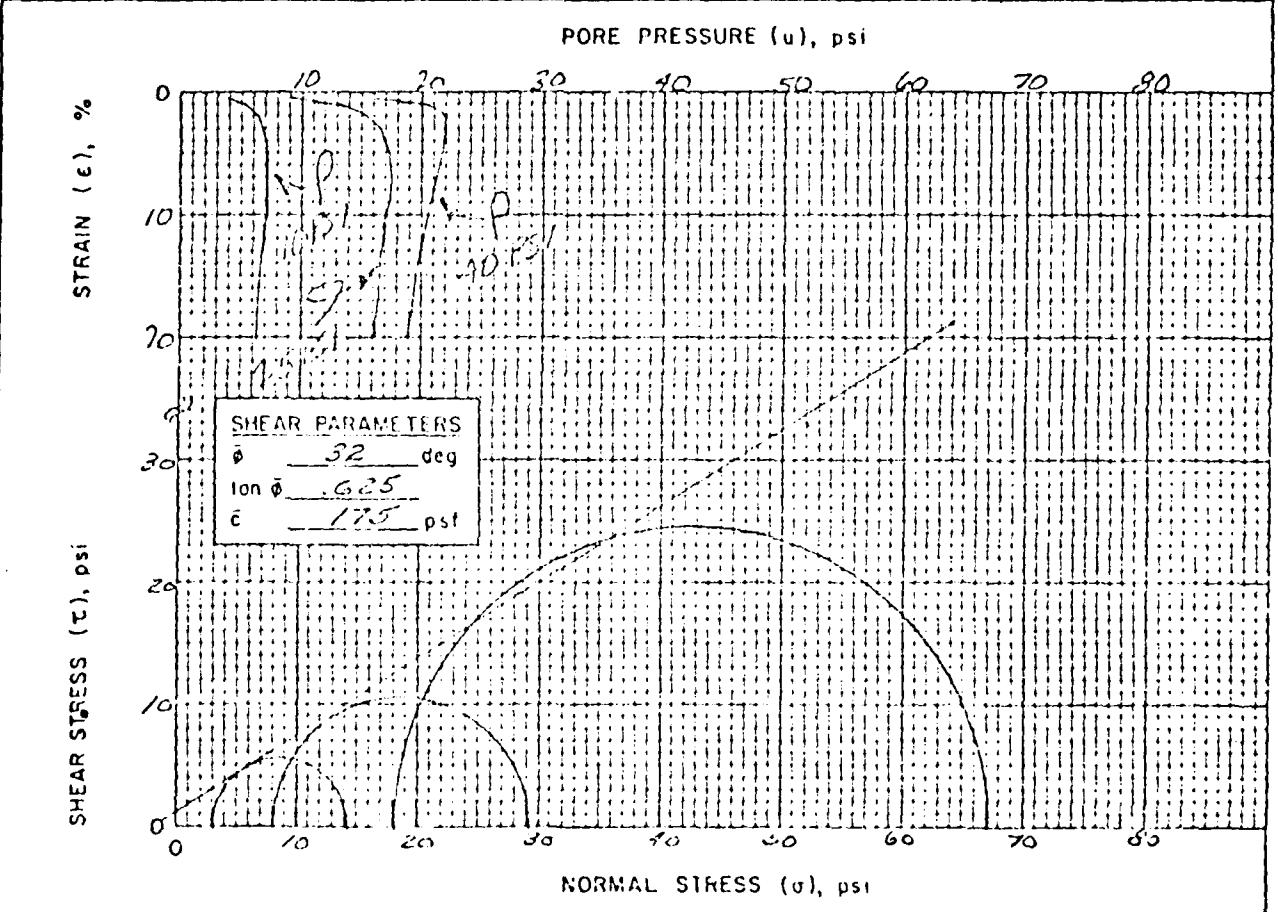

REMARKS: *BACK-PRESSURED*

RTM
278

MATERIALS TESTING REPORT U.S. DEPARTMENT of AGRICULTURE
 SOIL CONSERVATION SERVICE **TRIAxIAL SHEAR TEST**

PROJECT and STATE East Creek, State E-1, Massachusetts SAMPLE LOCATION 2000 1128 1:000

FIELD SAMPLE NO 2-1 DEPTH 4-5.5' GEOLOGIC ORIGIN _____

TYPE OF SAMPLE UNDISTURBED TESTED AT SMU - Lincoln APPROVED BY _____ DATE _____

INDEX TEST DATA		SPECIMEN DATA		TYPE OF TEST
USCS <u>CL</u>	LL <u>36</u> ; PI <u>14</u>	HEIGHT <u>3.0</u> "	DIAMETER <u>1.4</u> "	UU <input type="checkbox"/> CU <input type="checkbox"/> CU <input checked="" type="checkbox"/> CD <input type="checkbox"/>
% FINER (mm): 0.002 <u>23</u> ; 0.005 <u>31</u>		MATERIALS TESTED PASSED <u>#4</u> SIEVE		
0.074 (#200) <u>85</u>		METHOD OF PREPARATION <u>Trimmed</u>		
G _s (#4) <u>2.62</u> ; G _s (#4) _____		MOLDING MOISTURE _____%		
STANDARD: γ _d MAX. _____ pcf; w ₀ _____%		MOLDED AT _____% OF γ _d MAXIMUM		
MODIFIED: γ _d MAX. _____ pcf; w ₀ _____%				

DRY DENSITY		B PARAMETER	MOISTURE CONTENT, %			TIME OF CONSOLI- DATION (hrs)	MINOR PRINCIPAL STRESS σ ₃ (psi)	DEVIATOR STRESS σ ₁ - σ ₃ (psi)	AXIAL STRAIN AT FAILURE, E (%)
INITIAL pcf <input type="checkbox"/> g/cc <input checked="" type="checkbox"/>	CONSOLI- DATED pcf <input type="checkbox"/> g/cc <input type="checkbox"/>		START OF TEST	DEG OF SAT AT START OF TEST	END OF TEST				
<u>1.57</u>		<u>0.99</u>			<u>25.2</u>	<u>16.23</u>	<u>5</u>	<u>18.1</u>	<u>4.9</u>
<u>1.65</u>		<u>0.95</u>			<u>22.7</u>	<u>16.08</u>	<u>20</u>	<u>33.4</u>	<u>4.7</u>
<u>1.63</u>		<u>0.96</u>			<u>22.6</u>	<u>16.45</u>	<u>30</u>	<u>38.0</u>	<u>4.7</u>

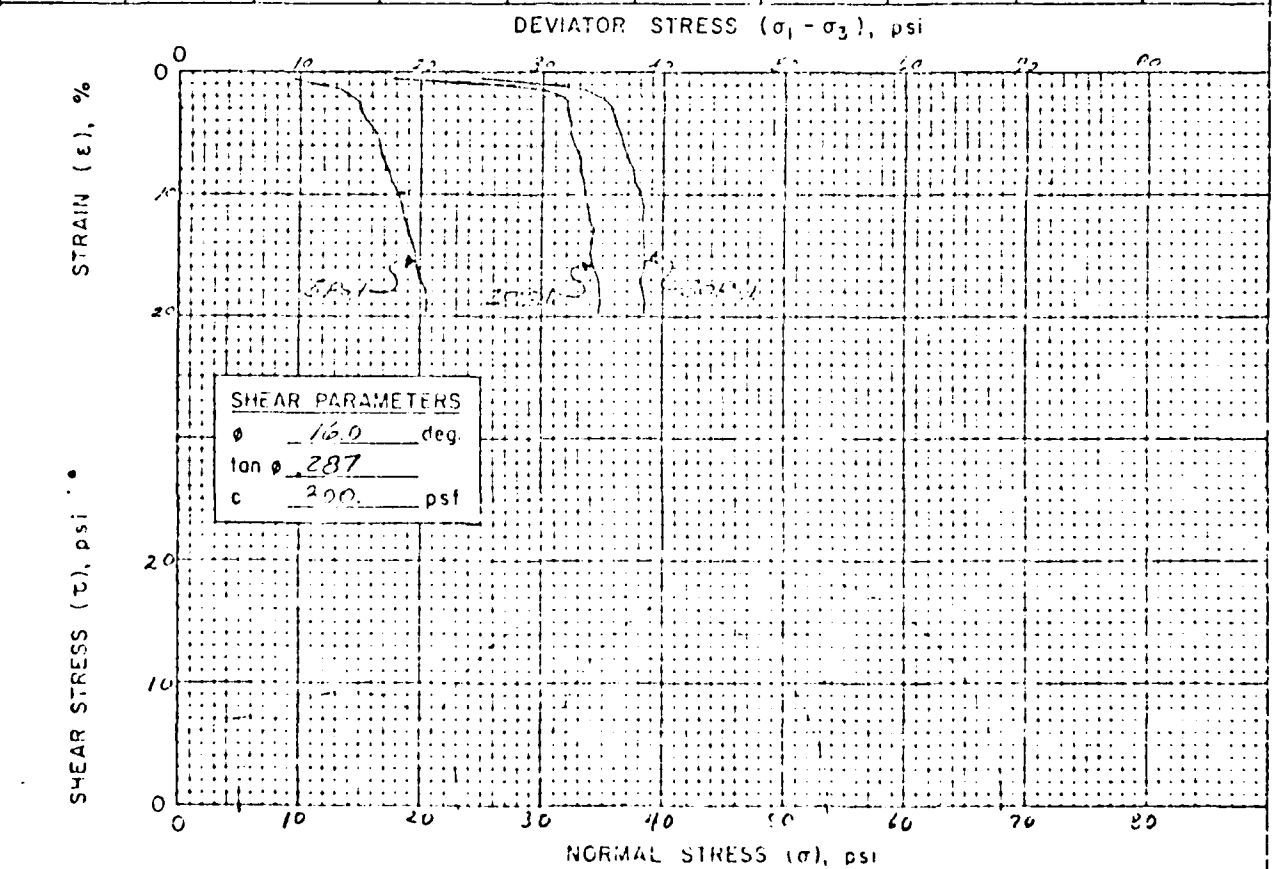

REMARKS Back-pressed /KTH

MATERIALS U.S. DEPARTMENT of AGRICULTURE **TRIAxIAL SHEAR TEST**
TESTING REPORT SOIL CONSERVATION SERVICE with pore pressure measured

PROJECT and STATE: *WEST WIND STATION, MASSACHUSETTS* SAMPLE LOCATION: *FIELD, 1+7.0 E. MAIN*

TYPE OF SAMPLE: *UNDISTURBED* TESTED AT: *SUB-LINCOLN* APPROVED BY: _____ DATE: _____

MINOR PRINCIPAL STRESS, σ_3 (psi)	PORE PRESSURE, u (psi)	EFFECTIVE MINOR PRINCIPAL STRESS, $\bar{\sigma}_3$ (psi)	DEVIATOR STRESS, $\sigma_1 - \sigma_3$ (psi)	FAILURE CRITERIA	AXIAL STRAIN AT FAILURE, ϵ (%)
5	-0.9	5.9	18.1		9.9
20	+6.7	13.3	33.4		9.9
30	+15.4	14.6	38.0		9.9

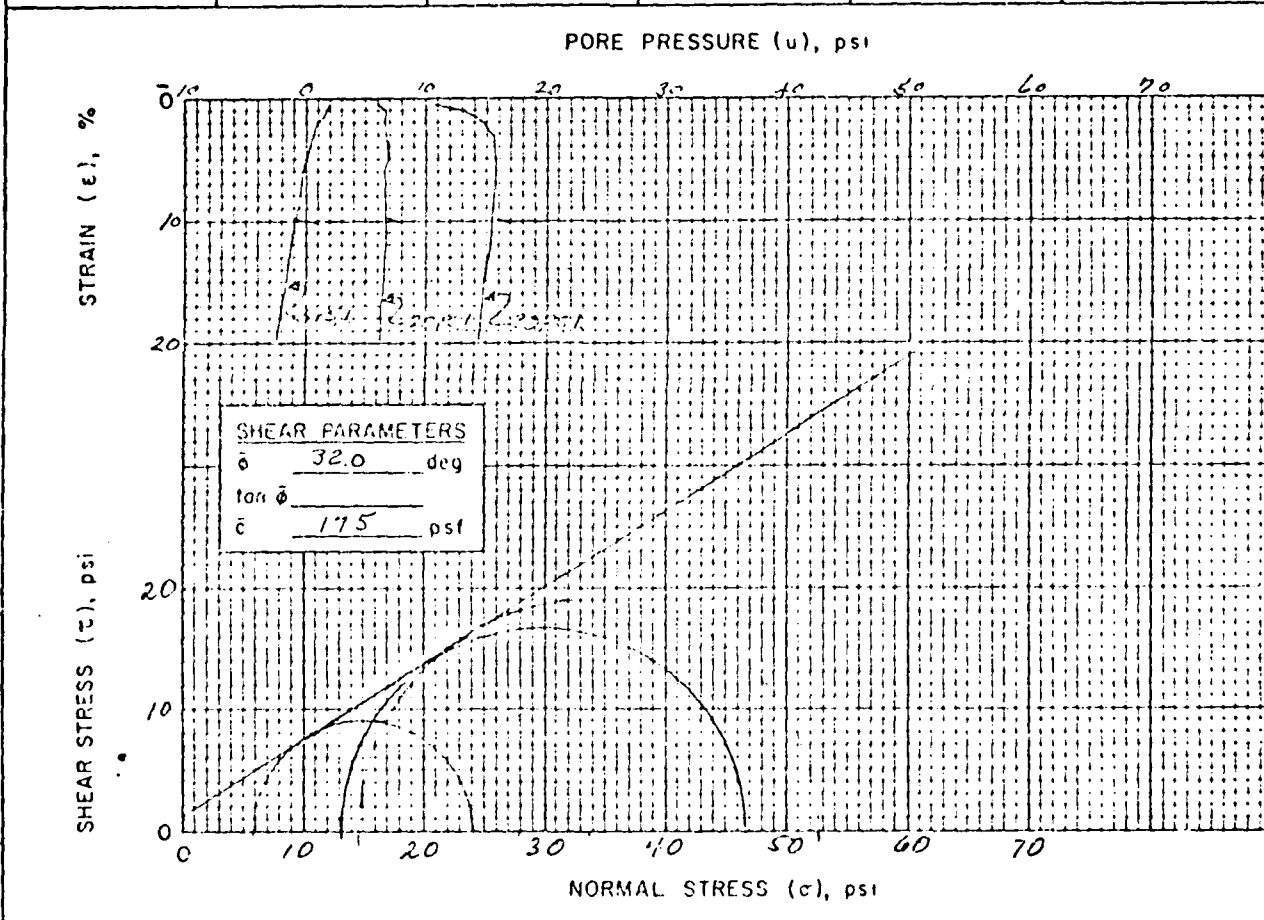

REMARKS: *BACK-PRESSURED* */ RSH*

MATERIALS TESTING REPORT U.S. DEPARTMENT OF AGRICULTURE SOIL CONSERVATION SERVICE TRIAXIAL SHEAR TEST

PROJECT and STATE: Lost Cr. E-1, MO SAMPLE LOCATION: Edam Sta 1798

FIELD SAMPLE NO: 2-1 DEPTH: 4-5.5' GEOLOGIC ORIGIN:

TYPE OF SAMPLE: Undisturbed TESTED AT: SML APPROVED BY: DATE: 2/13/76

INDEX TEST DATA			SPECIMEN DATA		TYPE OF TEST
USCS <u>CL</u>	LL <u>36</u>	PI <u>14</u>	HEIGHT <u>3.0</u> "	DIAMETER <u>1.4</u> "	UU <input type="checkbox"/>
% FINER (mm): 0.002 <u>23</u> ; 0.005 <u>31</u> ; 0.074 (#200) <u>85</u>			MATERIALS TESTED PASSED # <u>4</u> SIEVE		CU <input type="checkbox"/>
G _s (-#4) <u>2.62</u> ; G _s (+#4)			METHOD OF PREPARATION <u>Trimmed from an undisturbed core</u>		C _U <input checked="" type="checkbox"/>
STANDARD: γ _d MAX. _____ pcf; w _o _____ %			MOLDING MOISTURE _____ %		CD <input type="checkbox"/>
MODIFIED: γ _d MAX. _____ pcf; w _o _____ %			MOLDED AT _____ % OF γ _d MAXIMUM		

DRY DENSITY		B Parameter	MOISTURE CONTENT, %			TIME OF CONSOLIDATION (hrs)	MINOR PRINCIPAL STRESS σ ₃ (psi)	DEVIATOR STRESS σ ₁ - σ ₃ (psi)	AXIAL STRAIN AT FAILURE, ε (%)
INITIAL pcf <input checked="" type="checkbox"/> g/cc <input type="checkbox"/>	CONSOLIDATED pcf <input type="checkbox"/> g/cc <input type="checkbox"/>		START OF TEST	DEG OF SAT. AT START OF TEST	END OF TEST				
1.53		0.96			26.4	16.17	10	11.1	4.0
1.54		0.96			25.0	16.23	25	26.0	4.0
1.60		0.96			22.4	16.52	40	49.0 (11.1)	4.0 (1.9)
1.59		0.97			25.2	16.23	5	18.1	9.9
1.65		0.95			22.7	16.08	20	33.1	9.9
1.63		0.96			22.6	16.45	30	38.0	9.9

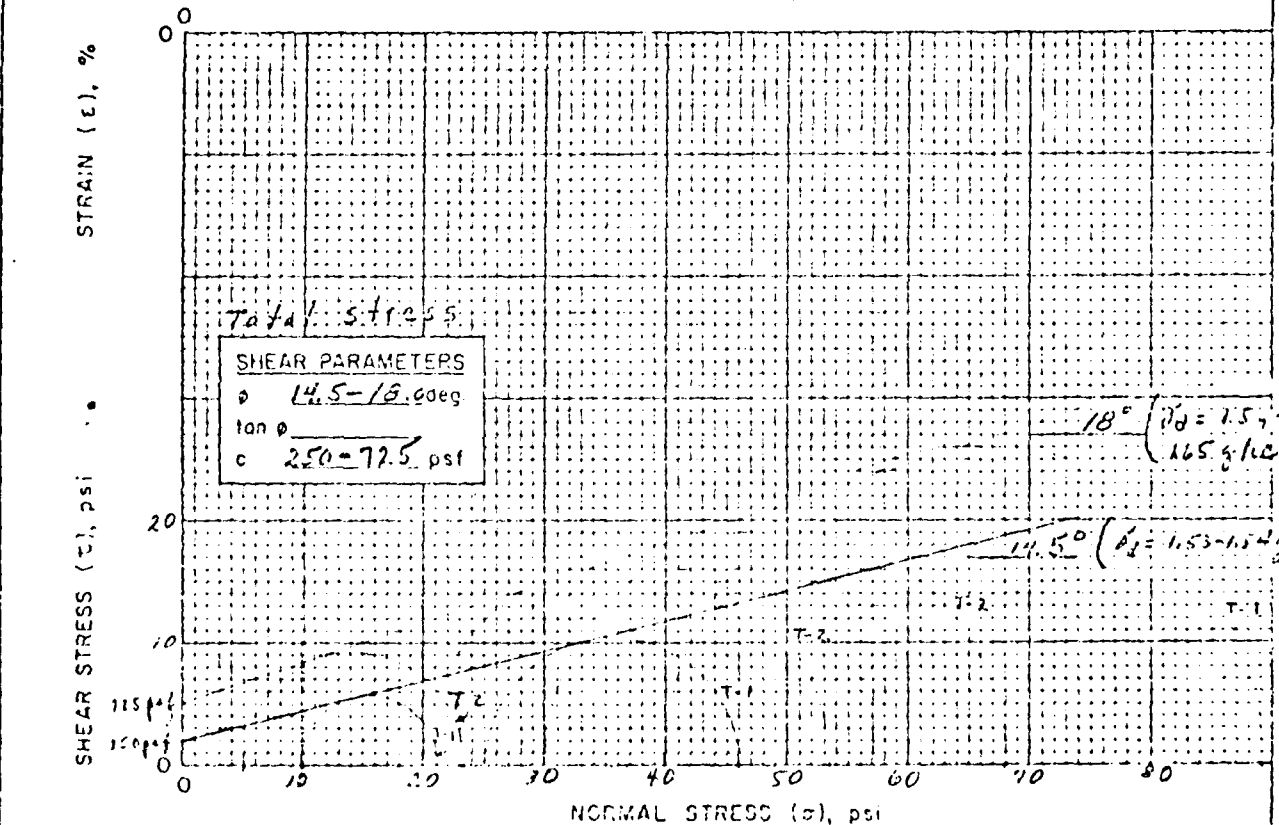

REMARKS: Composite Mohr envelopes from two CU triaxial tests. Sample appears to consist of two materials.

MATERIALS TESTING REPORT U.S. DEPARTMENT OF AGRICULTURE SOIL CONSERVATION SERVICE TRIAXIAL SHEAR TEST

PROJECT and STATE: Eastwood Site, E-1, Missouri SAMPLE LOCATION: BORROW, A 2425

FIELD SAMPLE NO: 11-2 DEPTH: 3-8' GEOLOGIC ORIGIN: _____

TYPE OF SAMPLE: SMPL. LINCOLN APPROVED BY: _____ DATE: _____

INDEX TEST DATA		SPECIMEN DATA		TYPE OF TEST
USCS <u>SC</u>	LL <u>36</u> ; PI <u>16</u>	HEIGHT <u>3.0</u> "	DIAMETER <u>1.2</u> "	
% FINER (mm): 0.002 <u>14</u> ; 0.005 <u>21</u> ; 0.074 (#200) <u>45</u>		MATERIALS TESTED PASSED # <u>4</u> SIEVE		
G _s (-#4) <u>2.65</u> ; G _s (+#4) _____		METHOD OF PREPARATION <u>STATIC</u>		
STANDARD: γ _d MAX. <u>112.5</u> pcf ; w ₀ <u>14.0</u> %		MOLDING MOISTURE <u>17.8</u> %		
MODIFIED: γ _d MAX. _____ pcf ; w ₀ _____ %		MOLDED AT <u>95.0</u> % OF γ _d MAXIMUM		

DRY DENSITY		B _r Parameter	MOISTURE CONTENT, %			TIME OF CONSOLIDATION (hrs)	MINOR PRINCIPAL STRESS σ ₃ (psi)	DEVIATOR STRESS σ ₁ - σ ₃ (psi)	AXIAL STRAIN AT FAILURE, E (%)
INITIAL pcf <input checked="" type="checkbox"/> g/cc <input type="checkbox"/>	CONSOLIDATED pcf <input type="checkbox"/> g/cc <input type="checkbox"/>		START OF TEST	DEG. OF SAT. AT START OF TEST	END OF TEST				
<u>106.9</u>		<u>0.94</u>			<u>20.5</u>	<u>16.18</u>	<u>10</u>	<u>26.5</u>	<u>4.0</u>
<u>106.8</u>		<u>0.98</u>			<u>20.0</u>	<u>16.50</u>	<u>25</u>	<u>36.9</u>	<u>4.0</u>
<u>107.0</u>		<u>0.96</u>			<u>19.5</u>	<u>16.23</u>	<u>40</u>	<u>45.0</u>	<u>4.0</u>

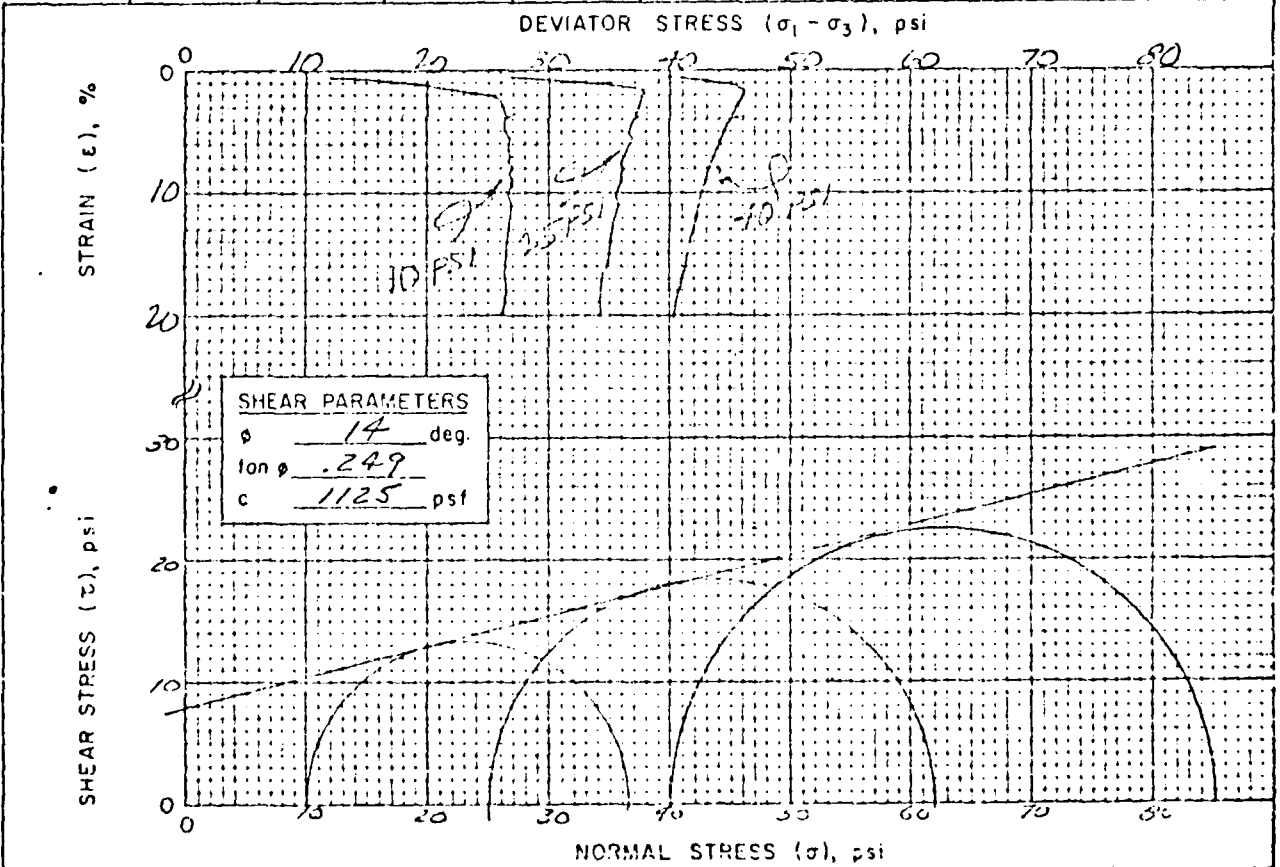

REMARKS BACK-PRESSURED

MATERIALS TESTING REPORT	U. S. DEPARTMENT of AGRICULTURE SOIL CONSERVATION SERVICE	TRIAxIAL SHEAR TEST with pore pressure measured
---------------------------------	--	---

PROJECT and STATE <u>WEST ROCK SITE E-1, MISSOURI</u>	SAMPLE LOCATION <u>BOCCONI, A 2+25</u>
--	---

TYPE OF SAMPLE <u>SOIL</u>	TESTED AT <u>SOIL-LINCOLN</u>	APPROVED BY	DATE
-------------------------------	----------------------------------	-------------	------

MINOR PRINCIPAL STRESS, σ_3 (psi)	PORE PRESSURE, u (psi)	EFFECTIVE MINOR PRINCIPAL STRESS, $\bar{\sigma}_3$ (psi)	DEVIATOR STRESS, $\sigma_1 - \sigma_3$ (psi)	FAILURE CRITERIA	AXIAL STRAIN AT FAILURE, ϵ (%)
<u>10</u>	<u>2.1</u>	<u>7.9</u>	<u>26.5</u>		<u>4.0</u>
<u>25</u>	<u>11.6</u>	<u>13.4</u>	<u>36.9</u>		<u>4.0</u>
<u>40</u>	<u>22.5</u>	<u>17.5</u>	<u>45.0</u>		<u>4.0</u>

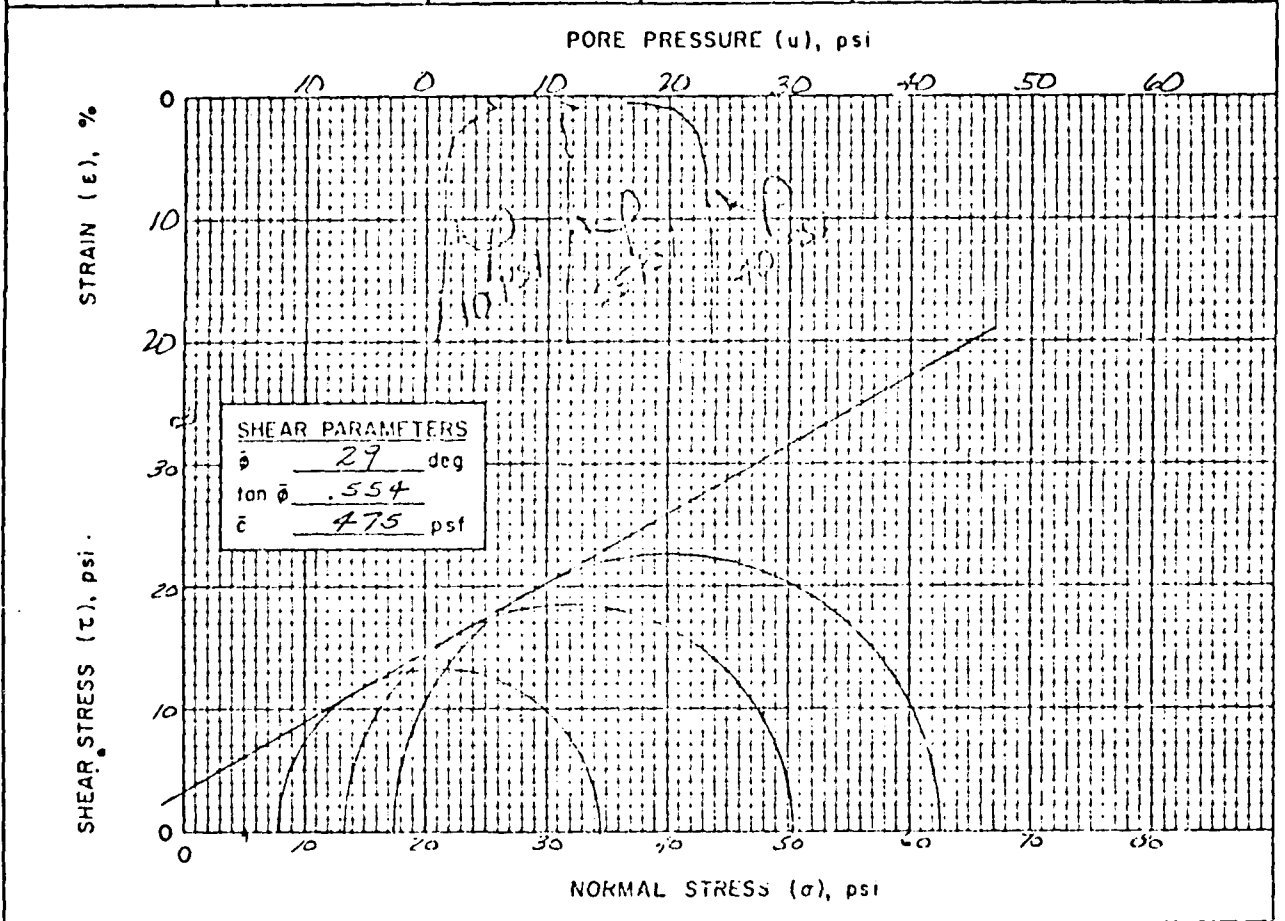

REMARKS BACK-PRESSURED

QTH
5/28

MATERIALS TESTING REPORT U. S. DEPARTMENT OF AGRICULTURE SOIL CONSERVATION SERVICE **COMPACTION AND PENETRATION RESISTANCE**

PROJECT and STATE: Lost Creek # E-1, Missouri.

FIELD SAMPLE NO: 101-2 LOCATION: Borrow A 2+25 DEPTH: 3-8'

GEOLOGIC ORIGIN: _____ TESTED AT: SML-LINCOLN APPROVED BY: _____ DATE: _____

CLASSIFICATION: SC LL 36 PI 16 CURVE NO. 1X OF 2

MAX. PARTICLE SIZE INCLUDED IN TEST: 3/4" STD (ASTM D-698) ; METHOD C

SPECIFIC GRAVITY (G_s): MINUS NO. 4 2.65 MOD. (ASTM D-1557) ; METHOD _____
PLUS NO. 4 2.47 OTHER TEST (SEE REMARKS)
AV. 2.61

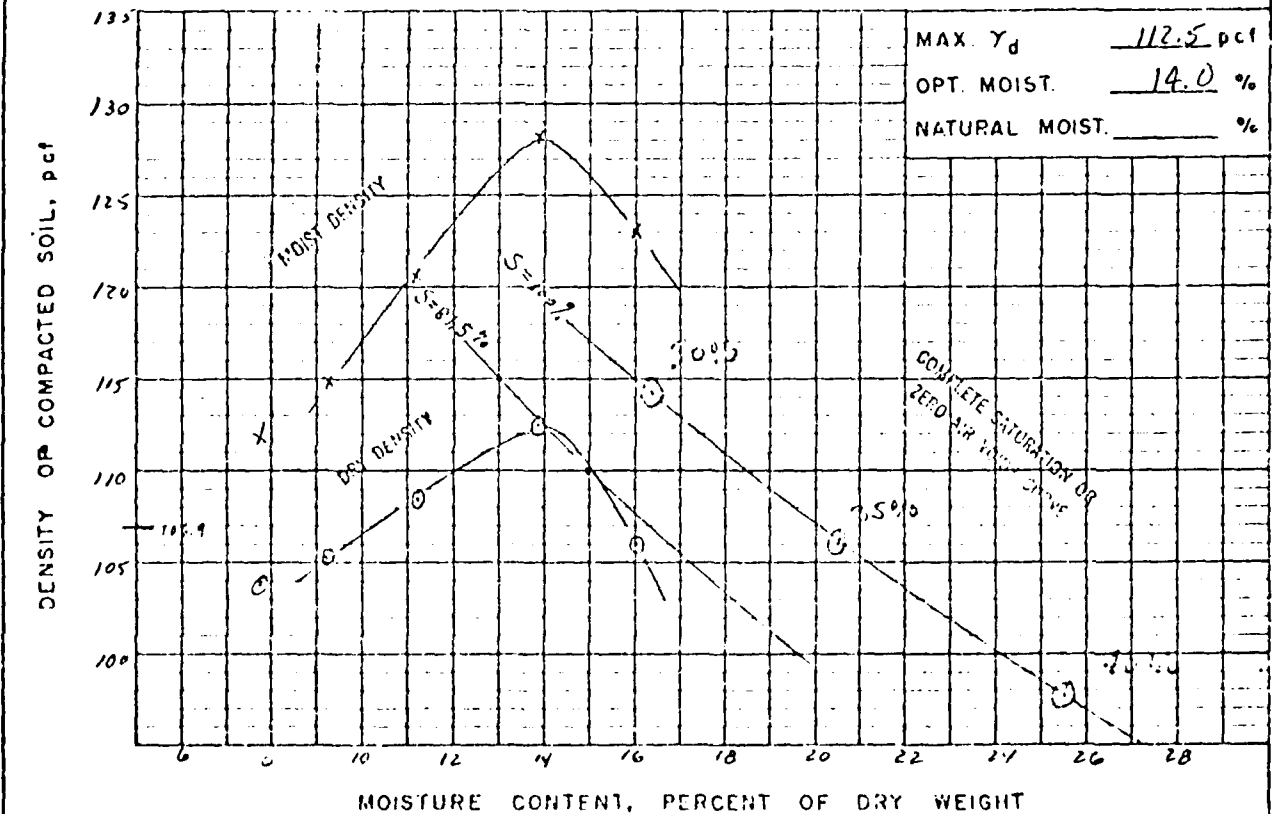
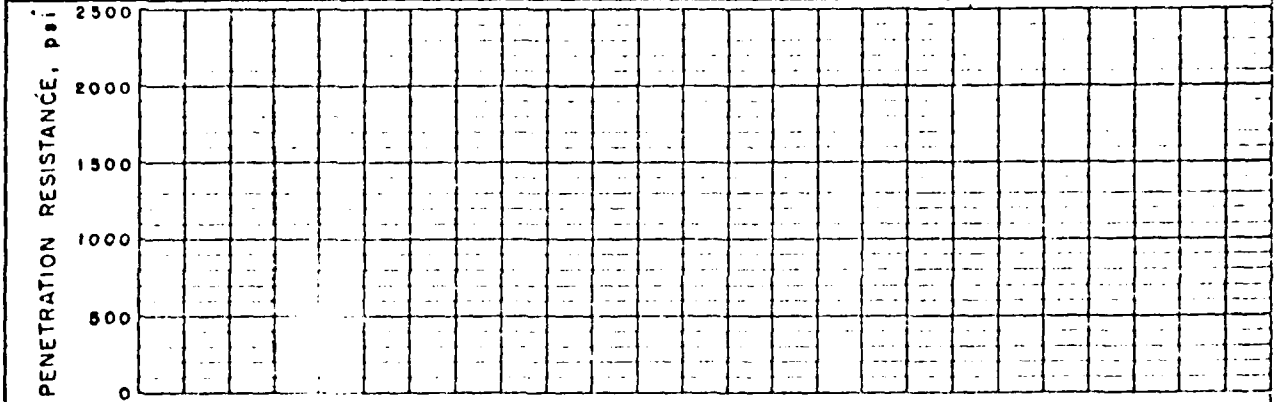

REMARKS: CURVE IS FOR THE MINIMUM RESILIENCE ACTION GRADATION OF TOTAL SAMPLE
 $< 10. 200$ 40 %; $< 10. 4$ 72 %; $< 1/2$ 111 122.6

MATERIALS TESTING REPORT	U. S. DEPARTMENT of AGRICULTURE SOIL CONSERVATION SERVICE	COMPACTION AND PENETRATION RESISTANCE
-----------------------------	--	--

PROJECT and STATE Lost Creek #E-1, Missouri

FIELD SAMPLE NO <u>124-1</u>	LOCATION <u>Borrow B 7+00</u>	DEPTH <u>2-7'</u>
---------------------------------	----------------------------------	----------------------

GEOLOGIC ORIGIN	TESTED AT <u>SML-LINCOLN</u>	APPROVED BY
-----------------	---------------------------------	-------------

CLASSIFICATION <u>CL</u> LL <u>36</u> PI <u>16</u>	CURVE NO. <u>2</u> OF <u>2</u>
MAX. PARTICLE SIZE INCLUDED IN TEST <u><#4</u>	SID (ASTM D-698) <input checked="" type="checkbox"/> ; METHOD <u>A</u>
SPECIFIC GRAVITY (G _s) {	MOD (ASTM D-1557) <input type="checkbox"/> ; METHOD _____
	OTHER TEST <input type="checkbox"/> (SEE REMARKS)

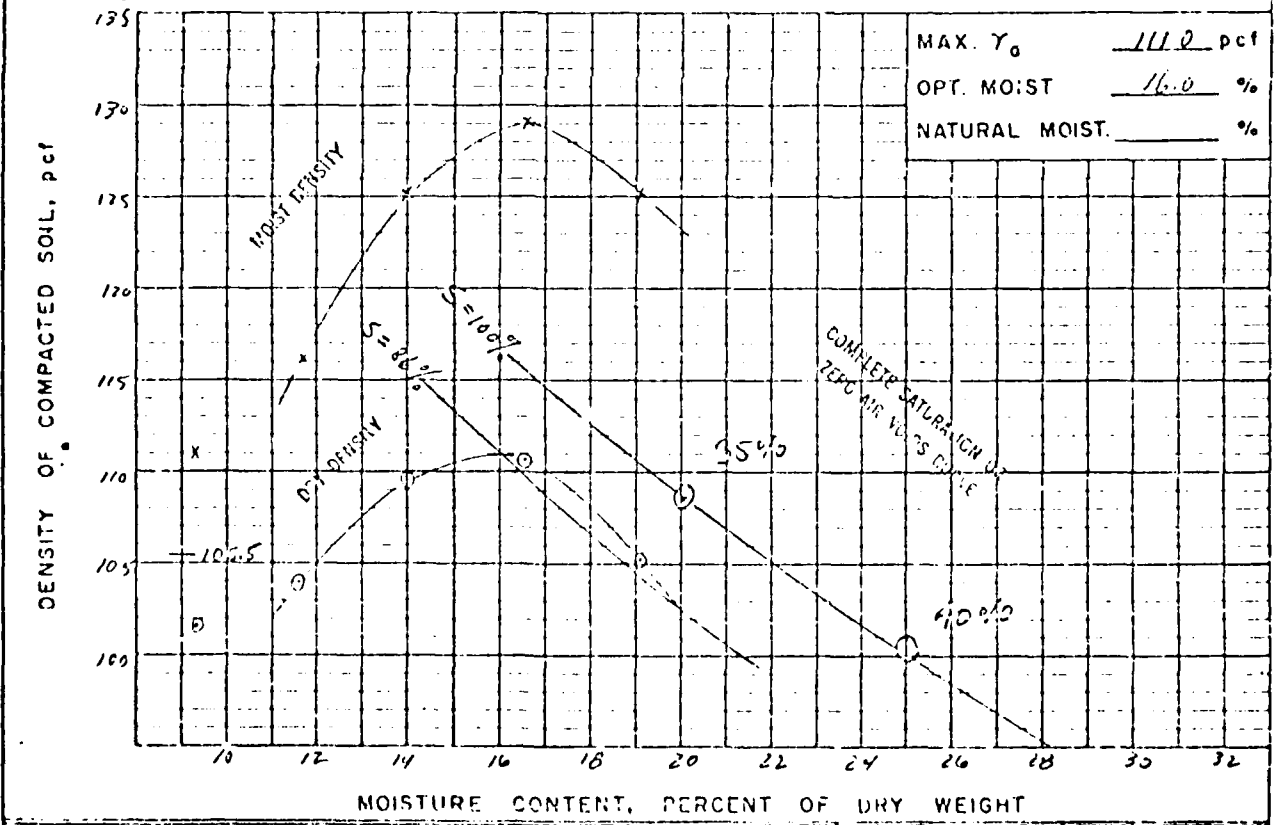
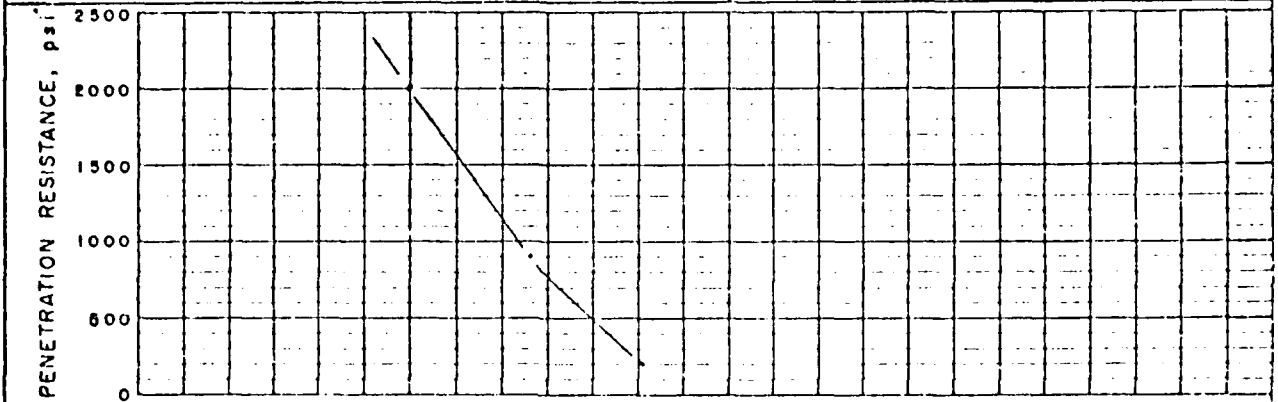

REMARKS

CURVE IS FOR THE MINUS NO. 4 FRACTION
 GRADATION OF TOTAL SAMPLE
< NO. 200 51 < NO. 4 85 < 20 IN. 100

MATERIALS TESTING REPORT U. S. DEPARTMENT of AGRICULTURE SOIL CONSERVATION SERVICE SUMMARY - SLOPE STABILITY ANALYSIS

PROJECT and STATE: LOUIT CREEK #E-1 MISSOURI DATE: 1-29-76

METHOD OF ANALYSIS: NAVROCK'S BLOCK ANALYZED AT: S. ALL, LINCOLN, NE. APPROVED BY:

TRIAL NO.	SLOPE	SOURCE AND USE OF MATERIALS	CLASSIFICATION	ADOPTED DESIGN DATA						REMARKS	F _s
				γ _d (pcf)	γ _{sub} (pcf)	φ (deg)	tan φ	c (psf)			
		Upstream - Full drawdown									
		Nonducts Block Analysis									
		Maximum Section @ Station 1+30									
117	2 1/2%	Embank. (29°-475) #5 Found. (14.5°-250), 15' berm @ elev. 975.6.									1.17
127	2 1/2%	Embank. (29°-475) #5 Found. (14.5°-250), 30' berm @ elev. 975.6.									1.35
136	2 1/2%	Embank. (29°-475) #5 Found. (14.5°-250), 10' berm @ elev. 973.3.									1.16
147	2 1/2%	Embank. (29°-475) #5 Found. (14.5°-250), 25' berm @ elev. 973.3.									1.50
150	2 1/2%	Embank. (29°-475) #5 Found. (14.5°-250), 10' berm @ elev. 973.3, Drain @ elev. 973.3.									1.29
150	2 1/2%	Same conditions as trial #136 except 50' berm @ elev. 973.3.									1.50
		Fluid Flow Section @ Station 1+30									
167	2 1/2%	Embank. (29°-475) #3 Found. (14.5°-250), 15' berm @ elev. 975.6.									1.27
170	2 1/2%	Embank. (29°-475) #3 Found. (14.5°-250), 32' berm @ elev. 975.6.									1.35
180	2 1/2%	Embank. (29°-475) #3 Found. (14.5°-250), 10' berm @ elev. 973.3.									1.27
190	2 1/2%	Embank. (29°-475) #3 Found. (14.5°-250), 62' berm @ elev. 973.3.									1.50
194	2 1/2%	Embank. (29°-475) #3 Found. (14.5°-250), 10' berm @ elev. 973.3, Drain @ elev. 973.3.									1.35
200	2 1/2%	Embank. (29°-475) #3 Found. (14.5°-250), 36' berm @ elev. 973.3, Drain @ elev. 973.3.									1.50
		Maximum Section @ Station 1+30									
147	2 1/2%	Same conditions as trial #147 except 5' Found. (15°-325)									1.72
136	2 1/2%	Same conditions as trial #136 except 5' Found. (12°-725)									1.93

ENGINEERING GEOLOGIC REPORT ON SCS E-1 LAKE SITE

NEWTON COUNTY, MISSOURI

LOCATION: NE¹, SW¹, NE¹, Sec. 16, T. 25 N., R. 33 W., Racine Quadrangle.

Dam was under construction on 26 October 1973. Core trench had been cut into weathered residual chert faulted and fractured. Locally, pinnacles are massive Burlington limestone where exposed particularly in the emergency spillway. However, the abutments were mainly of fractured chert both as loose rock fragments and as massive chert ledges.

Numerous springs were present in the valley floor at and upstream of the dam site. The valley is a gaining valley. Construction procedures included the placement of drainage facilities and collection of water from the springs for discharge downstream of the dam. Persons present during the inspection were Neil Randall, Soil Conservation Service, Columbia, Mo., and Don Hixson, Soil Conservation Service, Lincoln, Nebraska.

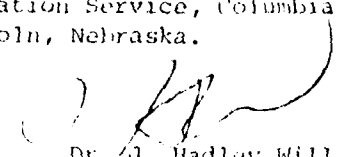

Dr. J. Hadley Williams, Chief
Engineering Geology Section
Geology & Land Survey
October 27, 1973

APPENDIX C

Overtopping Analysis

AD-A105 102

ANDERSON ENGINEERING INC SPRINGFIELD MO
NATIONAL DAM SAFETY PROGRAM, STRUCTURE E-1 (MO 20511); VERDIGRI--ETC(U)
AUG 80 J HEALY, S BRADY, N MORALES, T BECKLEY DACW43-80-C-0073
NL

F/G 13/13

UNCLASSIFIED

2 2
AD
5-00



END
DATE
FILMED
0 81
DTIC

From Racine, Mo. - Okla. - Kans. 7.5' Quad.

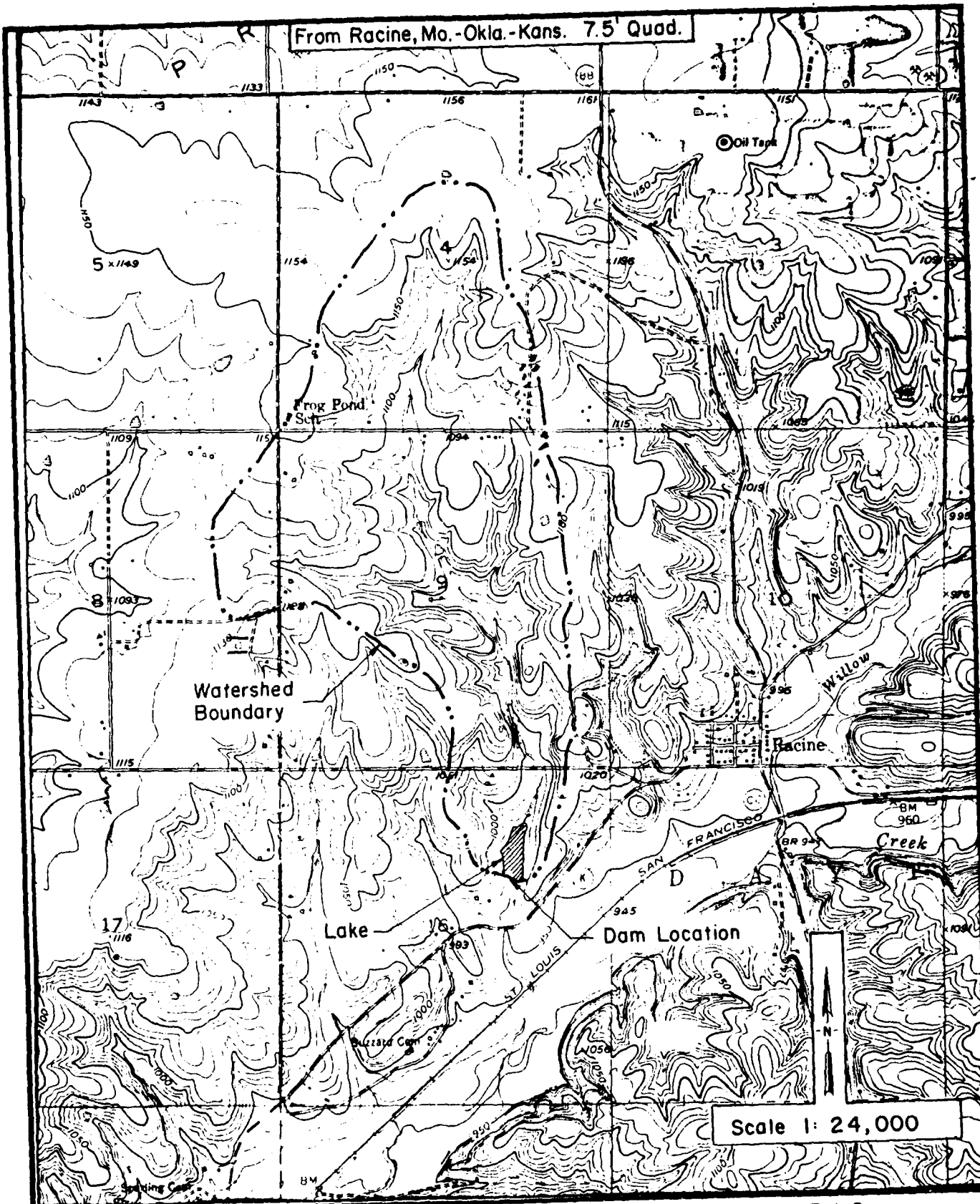

LAKE AND WATERSHED MAP



SPRINGFIELD, IL • PEORIA, IL • ROCKFORD, IL

Newton County Structure E-1 Dam
Newton County, Missouri
Mo. I.D. No. 20511

Sheet 1, Appendix C

APPENDIX C

HYDROLOGIC AND HYDRAULIC ANALYSIS

To determine the overtopping potential, flood routings were performed by applying the Probable Maximum Precipitation (PMP) to a synthetic unit hydrograph to develop the inflow hydrograph. The inflow hydrograph was then routed through the reservoir and spillway. The overtopping analysis was accomplished using the systemized computer program HEC-1 (Dam Safety Version), July 1978, prepared by the Hydrologic Engineering Center, U.S. Army Corps of Engineers, Davis, California.

The PMP was determined from regional charts prepared by the National Weather Service in "Hydrometeorological Report No. 33." Reduction factors were not applied. The rainfall distribution for the 24-hour PMP storm duration was assumed according to the procedures outlined in EM 1110-2-1411 (SPD Determination).

The synthetic unit hydrograph for the watershed was developed by the computer program using the SCS method. The parameters for the unit hydrograph are shown in Table 1 (Sheet 4, Appendix C).

The SCS curve number (CN) method was used in computing the infiltration losses for rainfall-runoff relationship. The CN values used, and the result from the computer output, are shown in Table 2 (Sheet 5, Appendix C).

The reservoir routing was accomplished by using the Modified Puls Method. The hydraulic capacity of the spillway was used as an outlet control in the routing. The hydraulic capacity of the spillway and the storage capacity of the reservoir were defined by the elevation-surface area-storage-discharge relationships shown in Table 3 (Sheet 5, Appendix C). This dam has been designed for flood control purposes, and the water surface elevation is maintained below the primary spillway invert elevation. To consider the effect of the reservoir storage, an antecedent storm of 25 percent and 50 percent of the PMF was considered (assuming the reservoir at the sedimentation pool elevation 975.6) to determine the starting reservoir elevation for the routing of 50 percent and 100 percent of the PMF respectively. The antecedent storms were assumed to occur four days prior to their corresponding storm. Both antecedent storms will fill the reservoir beyond the emergency spillway level, but at the end of the four days, the level of the reservoir will reduce to elevation 975.6 since the primary spillway is unregulated. Thus, the final routing analysis was accomplished considering the starting reservoir level at elevation 975.6.

The result of the routings of the PMF ratios indicate that the dam will pass the 1 percent probability flood without overtopping the dam.

The rating curve for the spillways (see Table 4 Sheet 6, Appendix C) was determined assuming orifice flow for the primary spillway and channel flow for the emergency spillway.

The flow over the crest of the dam during overtopping was determined using the non-level dam option (\$L and \$V cards) of the HEC-1 program. The program assumes critical flow over a broad-crested weir.

A summary of the routing analysis for different ratios of the PMF is shown in Table 5 (Sheet 7, Appendix C).

The computer input data, a summary of the output data, and a plot of the inflow-outflow hydrograph for the PMF are presented on Sheets 8, 9 and 10 of Appendix C.

TABLE 1
SYNTHETIC UNIT HYDROGRAPH

Parameters:

Drainage Area (A)	1.15 sq. miles
Length of Watercourse (L)	2.08 miles
Difference in elevation (H)	190 feet
Time of concentration (Tc)	0.80 hours
Lag Time (Lg)	0.48 hours
Time to peak (Tp)	0.565 hours
Peak Discharge (Qp)	985 c.f.s.
Duration (D)	10 min.

<u>Time (Min.)(*)</u>	<u>Discharge (cfs)(*)</u>
0	0
10	183
20	634
30	967
40	925
50	690
60	401
70	250
80	154
90	96
100	59
110	36
120	23
130	14
140	9
150	6
160	3

(*) From the computer output

FORMULA USED:

$$T_c = \left(\frac{11.9 L^3}{H} \right)^{0.385}$$

$$L_g = 0.6 T_c$$

$$T_p = \frac{D + L_g}{2}$$

$$Q_p = \frac{484 A \cdot Q}{T_p} \quad Q = \text{Excess Runoff} = 1 \text{ inch}$$

TABLE 2

RAINFALL-RUNOFF VALUES

<u>Selected Storm Event</u>	<u>Storm Duration (Hours)</u>	<u>Rainfall (Inches)</u>	<u>Runoff (Inches)</u>	<u>Loss (Inches)</u>
PMP	24	35.5	33.7	1.8

Additional Data:

- 1) Soil Conservation Service Soil Group B
- 2) Soil Conservation Service Runoff Curve CN = 86 (AMC III) for the PMF
- 3) Soil Conservation Service Runoff Curve CN = 71 (AMC II) for the
1 percent probability flood
- 4) Percentage of Drainage Basin Impervious 5 percent

TABLE 3

ELEVATION, SURFACE AREA, STORAGE AND DISCHARGE RELATIONSHIPS

<u>Elevation (feet-MSL)</u>	<u>Lake Surface Area (acres)</u>	<u>Lake Storage (acre-ft)</u>	<u>Spillway Discharge (cfs)</u>
960.0	0	0	
* 975.6	9.5	60	0
980.0	11.3	106	26
984.0	16.6	165	37
990.0	24.0	285	49
996.4	31.5	465	59
1000.0	36.3	590	1564
** 1002.9	41.5	700	4918
1005.0	43.3	790	7970
1010.0	50.3	1020	--

•*Primary spillway crest elevation

**Top of dam elevation

The above relationships were developed using data from the SCS plans and the U.S.G.S. SENECA, MO.-OKLA. 7.5 minute quadrangle map.

TABLE 4

SPILLWAYS RATING CURVE

<u>Reservoir Elevation</u> (Ft MSL)	<u>Primary Spillway</u> (c.f.s.)	<u>Emergency Spillway</u> (c.f.s.)	<u>Total Discharge</u> (c.f.s.)
975.16	0		0
980.0	26		26
984.0	37		37
990.0	49		49
996.4	59	0	59
996.9	60	56	116
997.4	61	188	249
997.9	61	374	435
998.4	62	610	672
999.4	63	1250	1313
1000.4	65	2060	2125
1001.4	66	3080	3146
1002.4	67	4220	4287
* 1002.9	68	4850	4918
1003.4	69	5500	5569
1004.4	70	6980	7050
1005.4	71	8560	8631
1006.4	72	10300	10372

* Top of Dam Elevation

METHOD USED:

- 1) Primary Spillway: Assuming orifice flow

$$Q = C.A. (2 g.h)^{1/2}$$

Q = Discharge in c.f.s.

C = Discharge coefficient = 0.60

A = Opening area in ft² (14" x 28")

g = Acceleration of gravity = 32.2 ft/sec²

h = Head measured from reservoir elevation to center of orifice (in ft)

- 2) Emergency Spillway: Assuming open channel flow

Using charts from "UD Method of Reservoir Flood Routing," S.C.S. Technical Release No. 35, February 1967.

TABLE 5

RESULTS OF FLOOD ROUTINGS

Ratio of PMF	Peak Inflow (CFS)	Peak Lake Elevation (ft.-MSL)	Total Storage (AC.-FT.)	Peak Outflow (CFS)	Depth (ft.) Over Top of Dam
	0	* 975.6	60	26	
	0	** 984.0	165	37	
0.20	1756	997.1	488	157	
0.30	2634	998.9	550	967	
0.40	3512	1000.4	604	2096	
0.50	4390	1001.4	644	3166	
0.60	5268	1002.2	674	4074	
0.70	6147	*** 1002.9	699	4898	0
0.80	7025	1003.5	723	5658	0.6
0.90	7903	1003.9	745	6534	1.0
1.00	8781	1004.4	762	7507	1.5

The percentage of the PMF that will reach the top of the dam is 70 percent.

- * Primary spillway crest elevation
- ** Starting reservoir level used for routings
- *** Top of dam elevation

PEAK FLOW AND STORAGE (END OF PERIOD) SUMMARY FOR MULTIPLE PLAN-RATIO ECONOMIC COMPUTATIONS
 FLOWS IN CUBIC FEET PER SECOND (CUBIC METERS PER SECOND)
 AREA IN SQUARE MILES (SQUARE KILOMETERS)

OPERATION	STATION	AREA	PLAN	RATIO 1	RATIO 2	RATIO 3	RATIO 4	RATIO 5	RATIO 6	RATIO 7	RATIO 8	RATIO 9
				0.20	0.30	0.40	0.50	0.60	0.70	0.80	0.90	1.00
HYDROGRAPH AT	1	1.15 (2.98)	1	1756. (49.73)	2634. (74.59)	3512. (99.46)	4390. (124.32)	5268. (149.19)	6147. (174.05)	7025. (198.91)	7903. (223.78)	8781. (248.64)
ROUTED TO	2	1.15 (2.98)	1	157. (4.45)	967. (27.37)	2096. (59.34)	3166. (89.65)	4074. (115.36)	4898. (138.70)	5658. (160.20)	6534. (185.02)	7507. (212.58)

RATIOS APPLIED TO FLOWS

SUMMARY OF DAM SAFETY ANALYSIS

PLAN 1	ELEVATION	INITIAL VALUE	SPILLWAY CREST	TOP OF DAM
	STORAGE	984.00	984.00	1002.90
	OUTFLOW	165.	165.	700.
		37.	37.	4918.

RATIO OF PMF	MAXIMUM RESERVOIR W.S.ELEV	MAXIMUM DEPTH OVER DAM	MAXIMUM STORAGE AC-FT	MAXIMUM OUTFLOW CFS	DURATION OVER TOP HOURS	TIME OF MAX OUTFLOW HOURS	TIME OF FAILURE HOURS
0.20	997.06	0.00	488.	157.	0.00	19.00	0.00
0.30	998.86	0.00	550.	967.	0.00	17.17	0.00
0.40	1000.36	0.00	604.	2096.	0.00	16.50	0.00
0.50	1001.42	0.00	644.	3166.	0.00	16.50	0.00
0.60	1002.21	0.00	674.	4074.	0.00	16.33	0.00
0.70	1002.88	0.00	699.	4898.	0.00	16.33	0.00
0.80	1003.45	0.55	723.	5658.	0.67	16.33	0.00
0.90	1003.94	1.04	745.	6534.	0.83	16.33	0.00
1.00	1004.36	1.46	762.	7507.	1.00	16.33	0.00

PMF RATIOS
 OUTPUT DATA

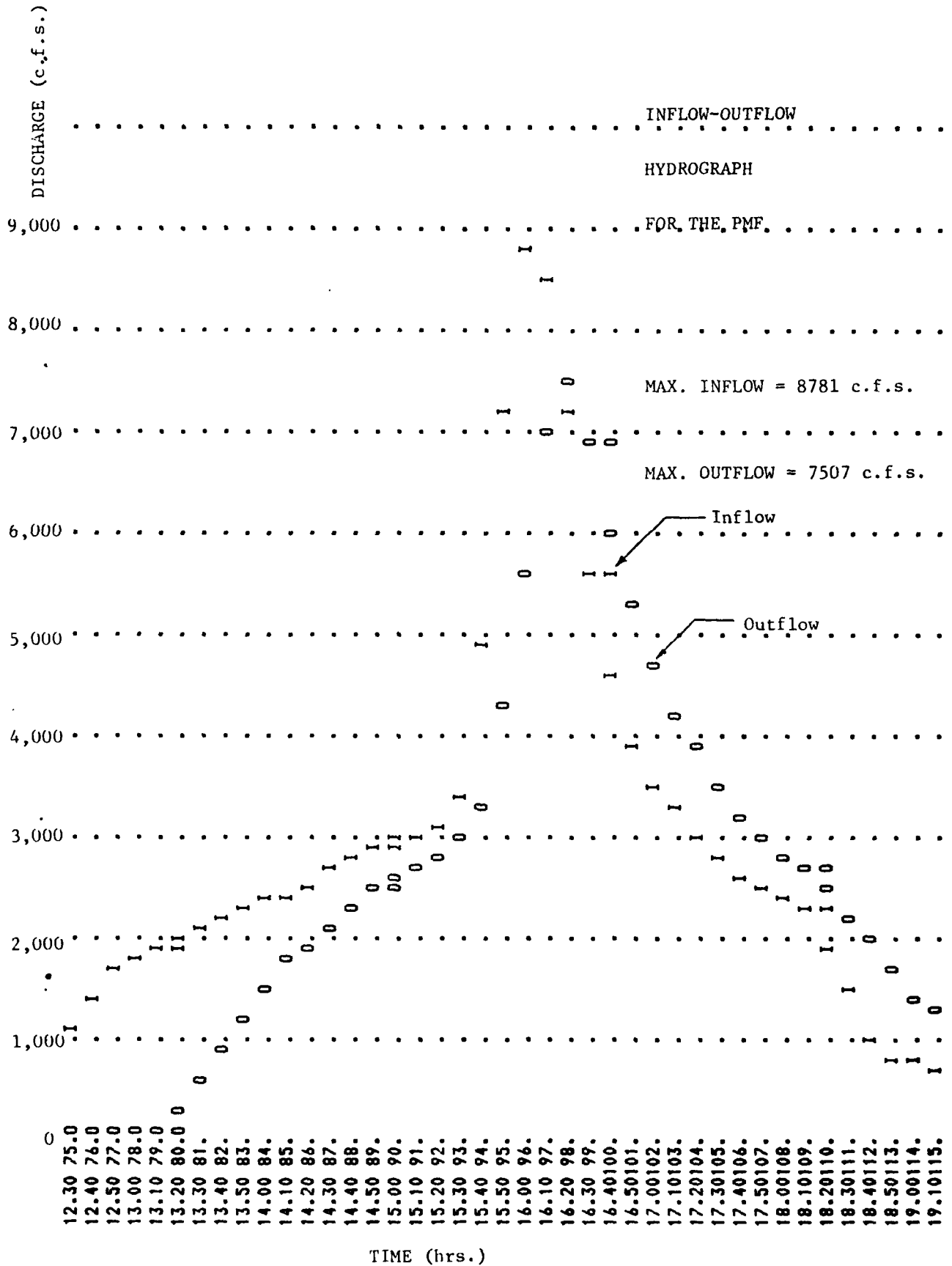

APPENDIX D

Photographs

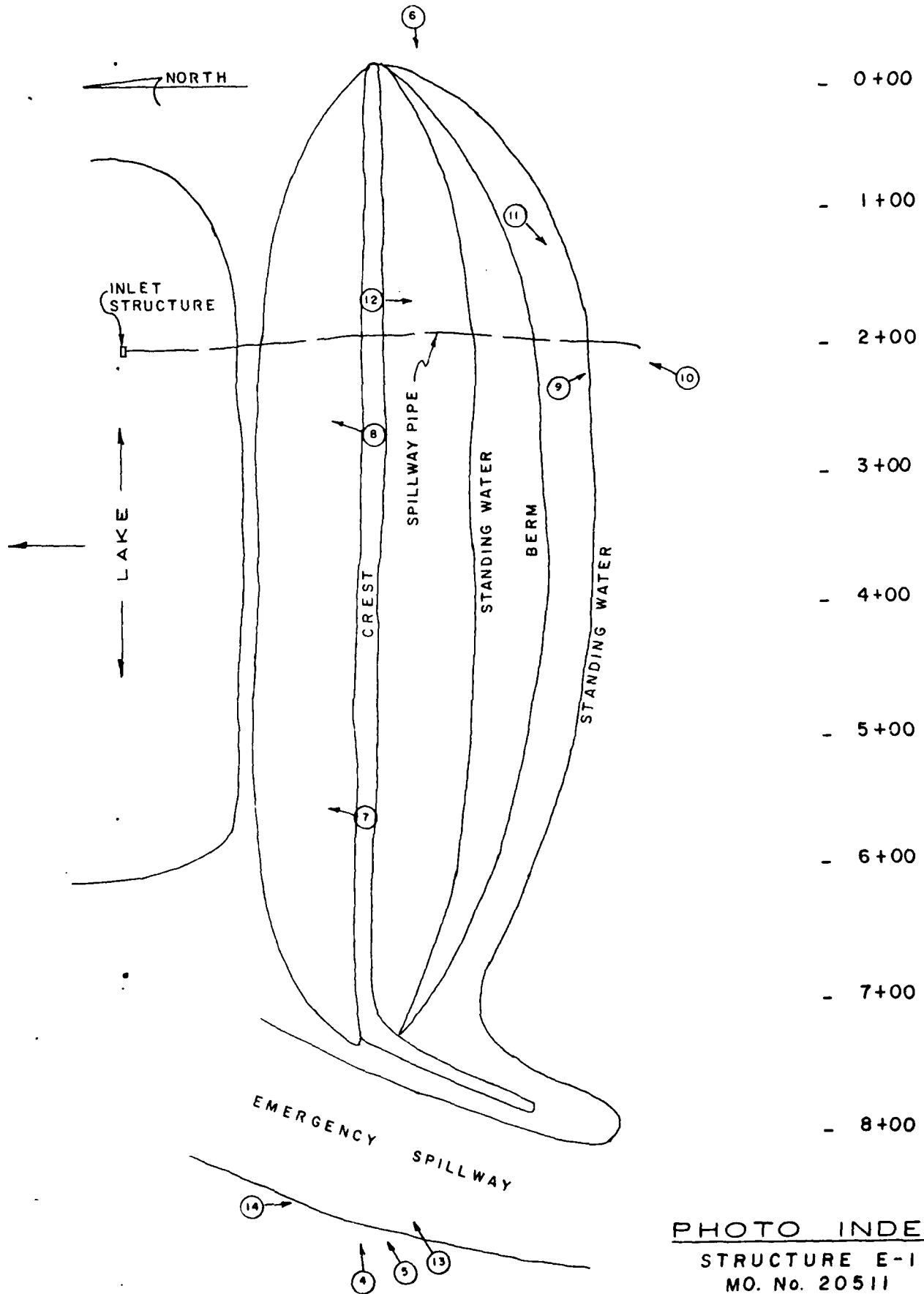
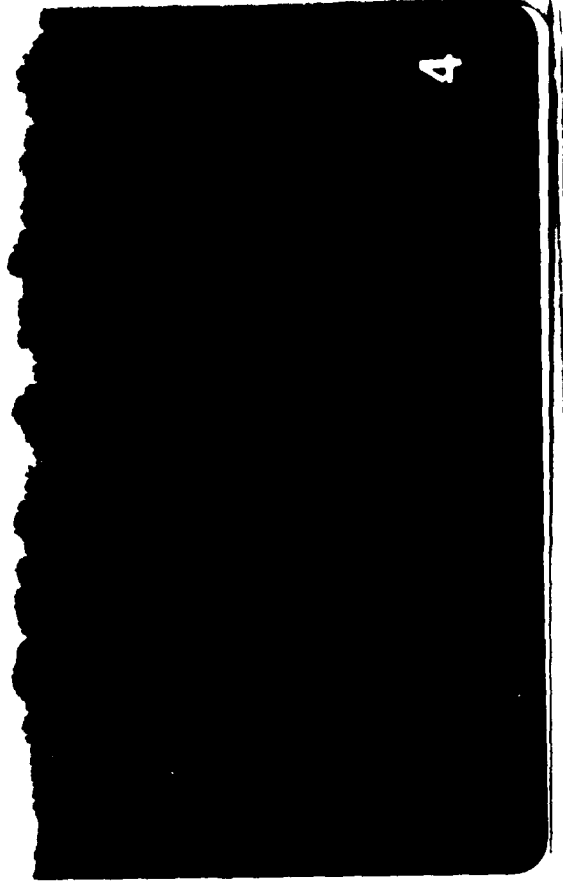
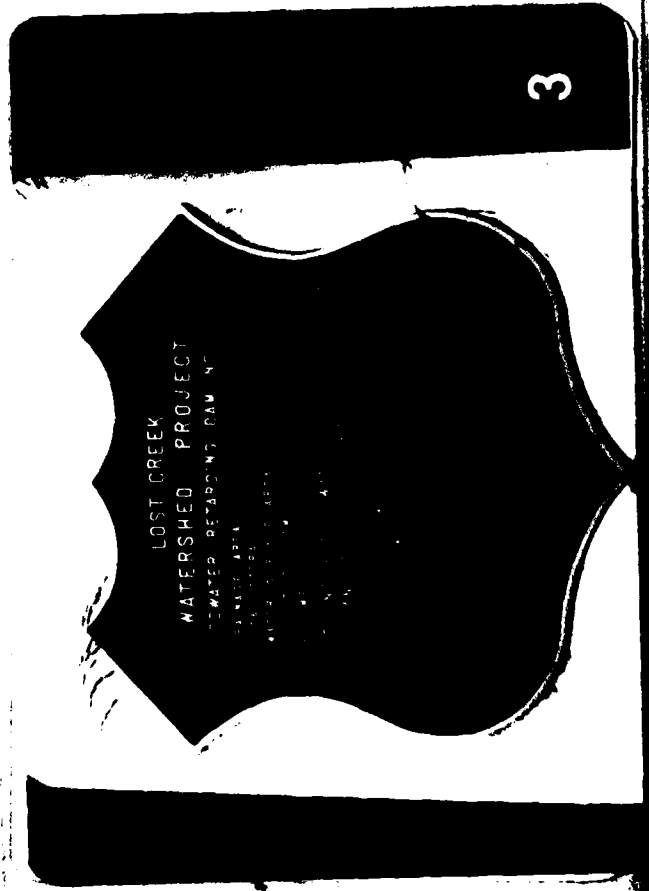
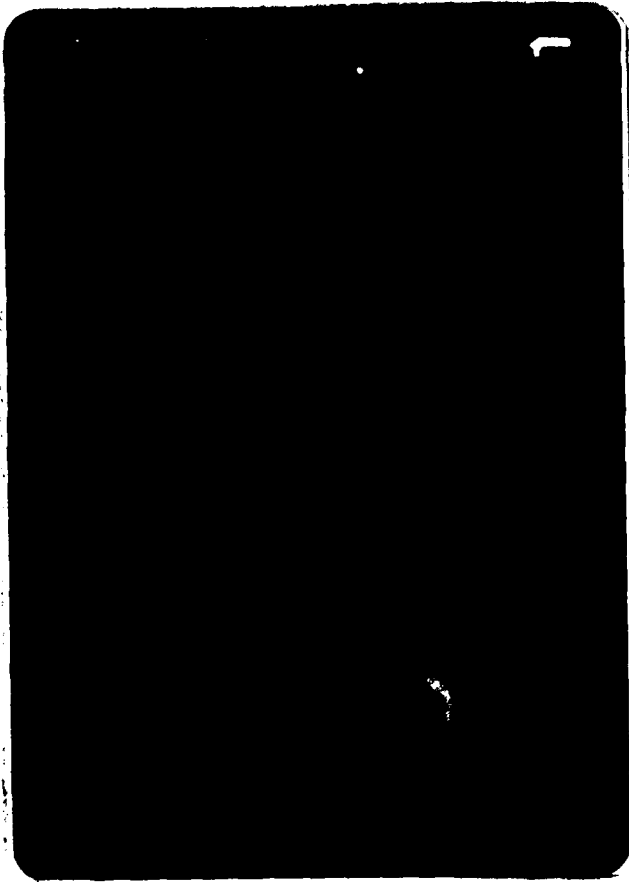
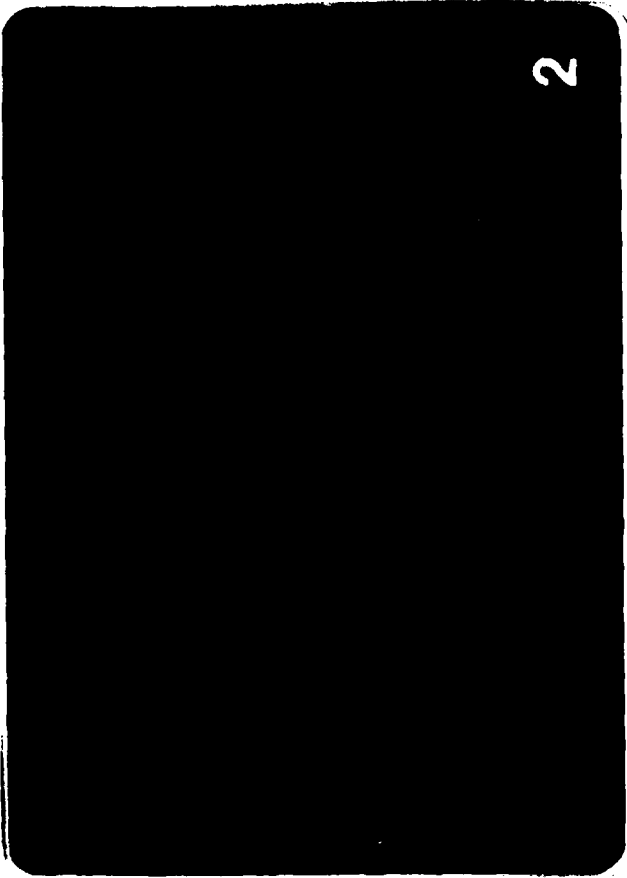
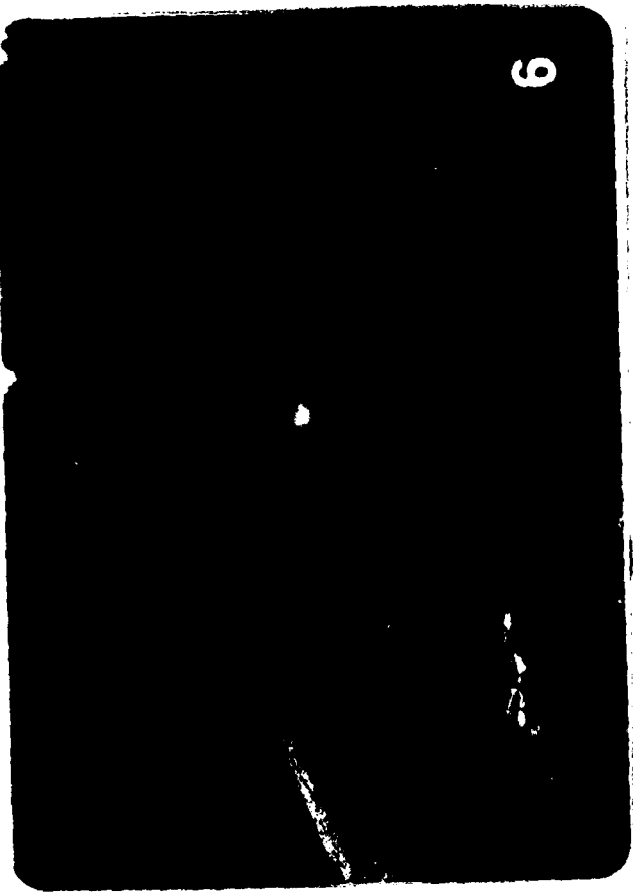

PHOTO INDEX
 STRUCTURE E-1
 MO. No. 20511

LIST OF PHOTOGRAPHS

<u>Photo No.</u>	<u>Description</u>
1	Aerial View of Dam
2	Aerial View of Dam
3	Closeup of Project Plaque
4	View of Crest (Looking East)
5	View of Upstream Embankment Face (Looking East)
6	View of Downstream Embankment Face (Looking West)
7	View of Lake from Crest (Looking North)
8	View of Inlet Structure
9	View of Spillway Pipe Outlet (Looking Southeast)
10	View of Spillway Pipe Outlet (Looking North)
11	View of Spillway Pipe Outlet (Looking Southwest)
12	View of Downstream Channel (Looking South)
13	View of Emergency Spillway (Looking Northeast)
14	View of Emergency Spillway (Looking Southeast)
15	Aerial View during Construction (August 1979)
16	Aerial View during Construction (August 1979)





6



8

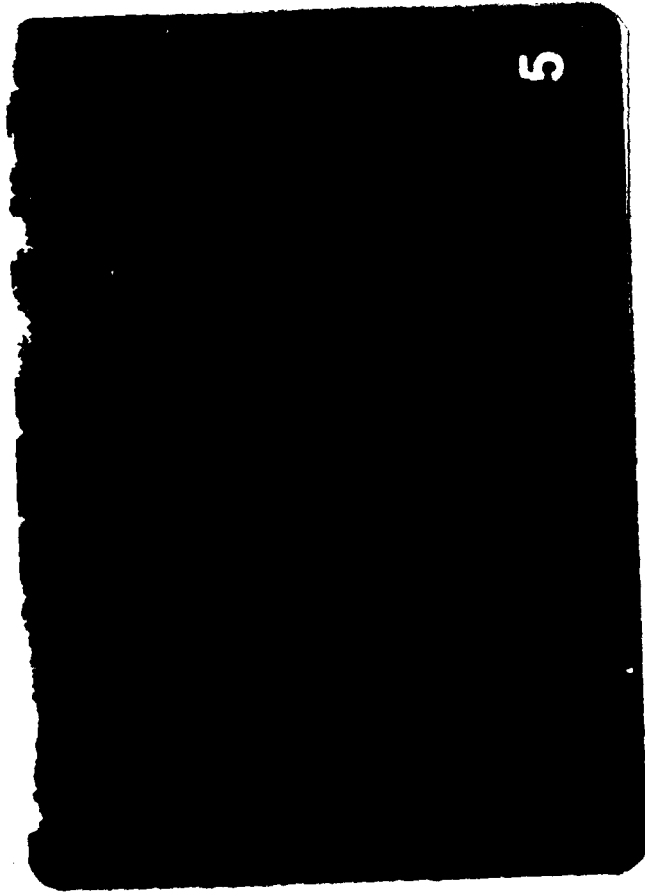

5

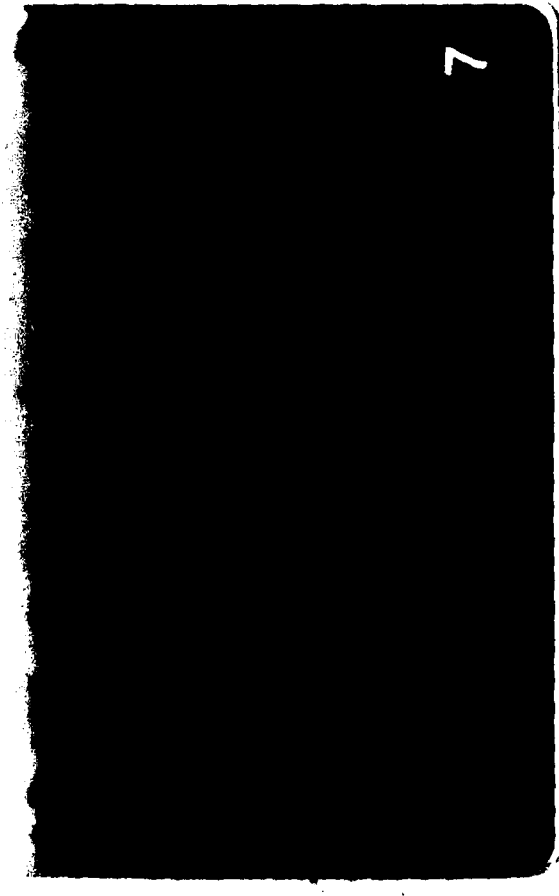

7

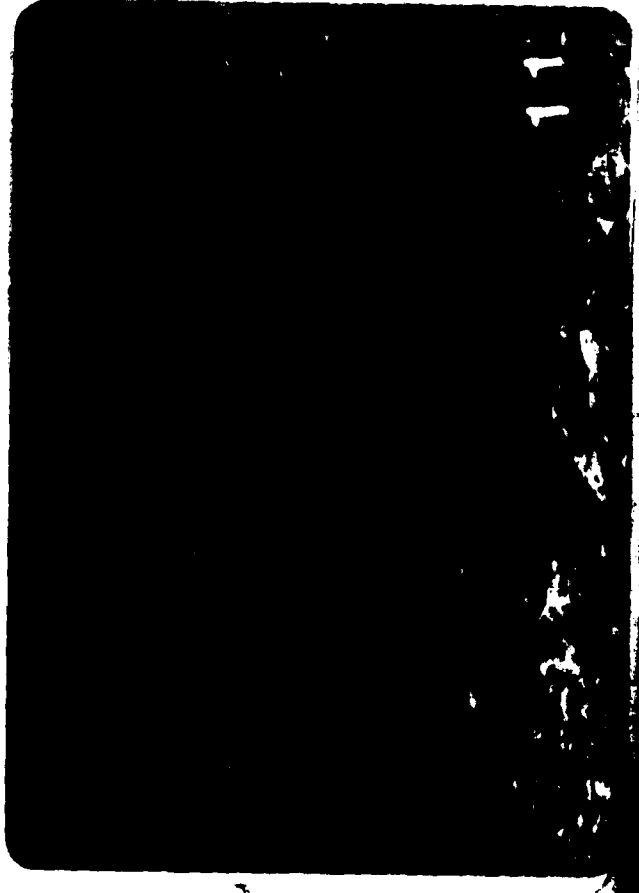
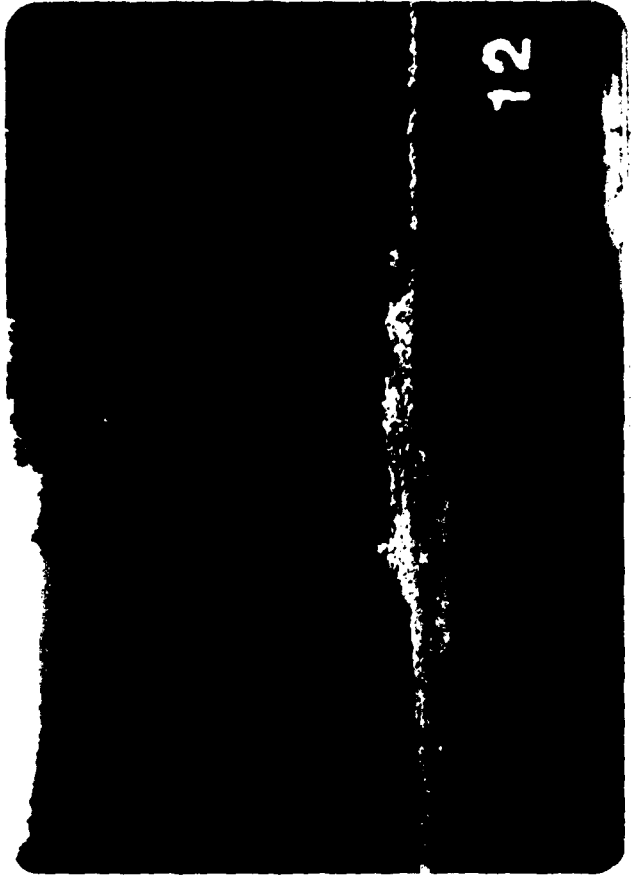
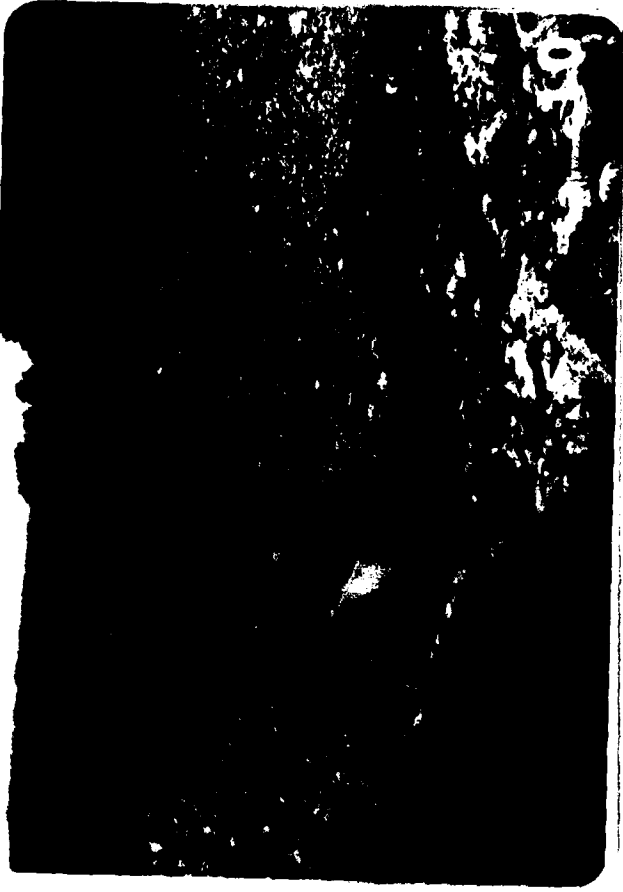

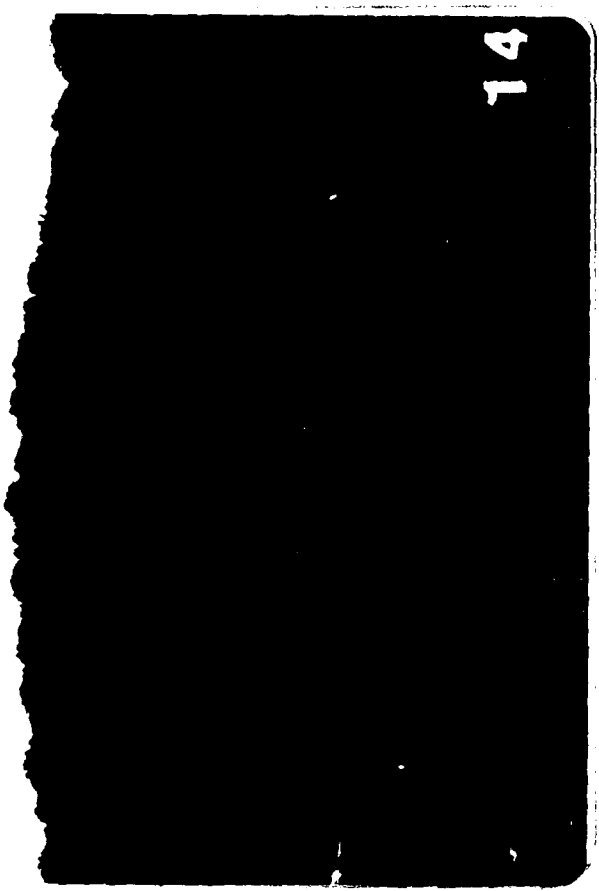

14

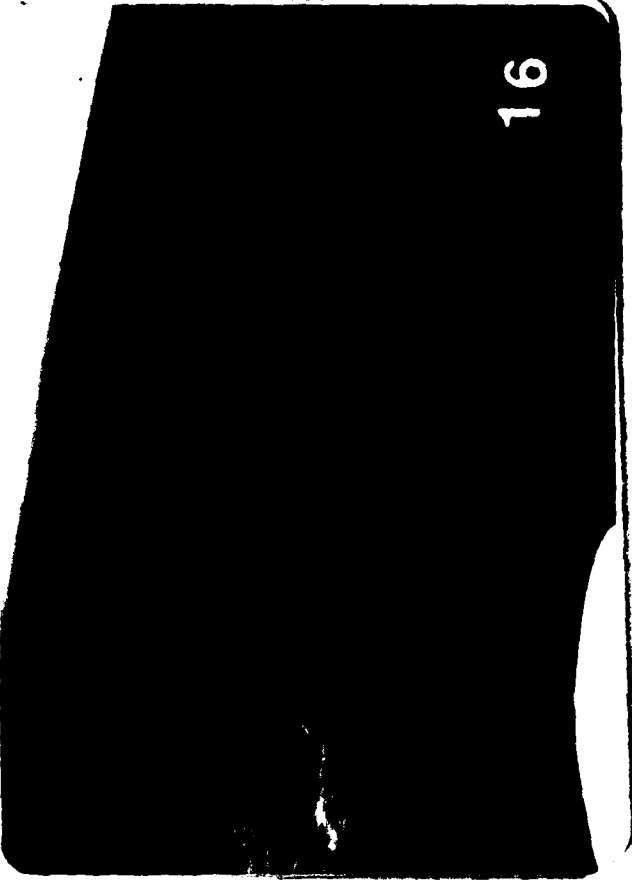

16

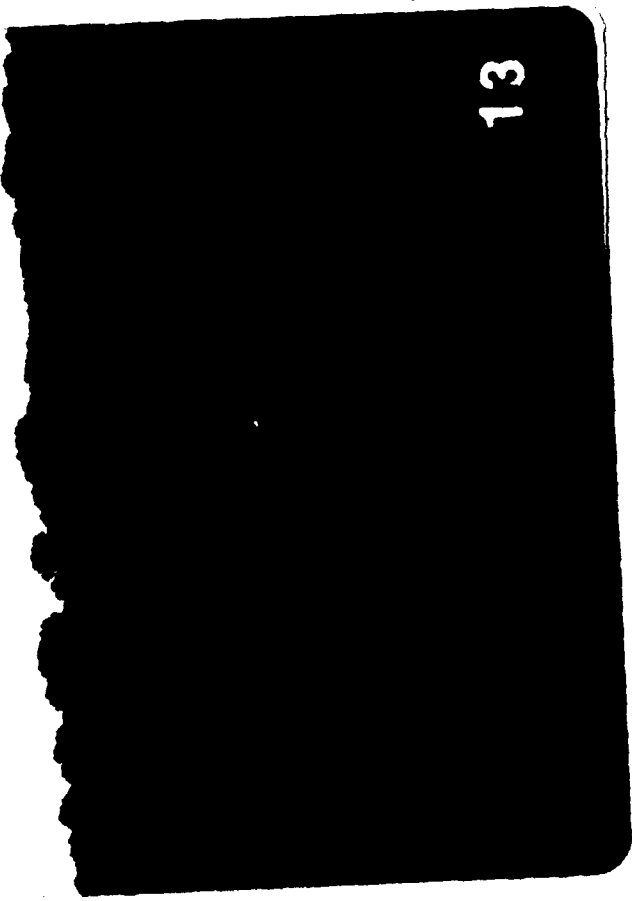

13

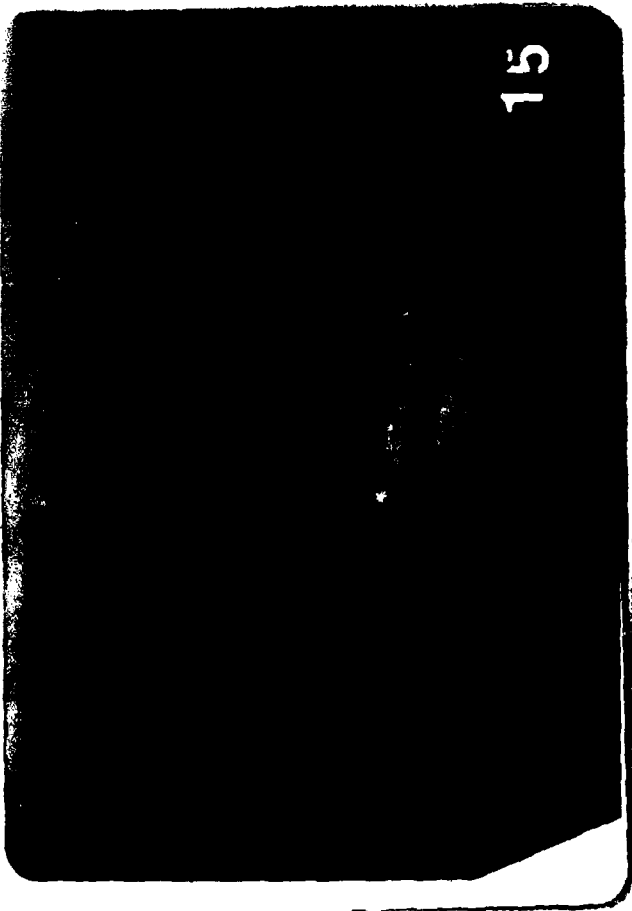

15