

AD-A105 280

HOSKINS-WESTERN-SONDEREGGER INC LINCOLN NE  
NATIONAL DAM SAFETY PROGRAM, OKAYDY RESERVOIR DAM (MO 10001) MI--ETC(U)  
JUN 79 R S DECKER, G G JAMISON, M MCMEEKIN DACW43-79-C-0046

F/G 13/13

UNCLASSIFIED

NL

1 OF 1  
AD A  
05/80

END  
DATE  
FILMED  
10-81  
DTIC

**LEVEL II**

**MISSOURI - KANSAS CITY BASIN**

**1**

*J*

**AD A 1 0 5 2 8 0**

**OKAYDY RESERVOIR DAM  
HOWARD COUNTY, MISSOURI  
MO. 10001**

**PHASE 1 INSPECTION REPORT  
NATIONAL DAM SAFETY PROGRAM**



**United States Army  
Corps of Engineers**  
... Serving the Army  
... Serving the Nation

**St. Louis District**

**DTIC  
ELECTE**  
**S** OCT 9 1981 **D**  
**D**

**DTIC FILE COPY**

**PREPARED BY: U.S. ARMY ENGINEER DISTRICT, ST. LOUIS**

**FOR: STATE OF MISSOURI**

**DISTRIBUTION STATEMENT A**  
Approved for public release  
Distribution Unlimited

**JUNE, 1979**

**81 10 7 094**

UNCLASSIFIED

SECURITY CLASSIFICATION OF THIS PAGE (When Data Entered)

REPORT DOCUMENTATION PAGE		READ INSTRUCTIONS BEFORE COMPLETING FORM	
1. REPORT NUMBER	2. GOVT ACCESSION NO.	3. RECIPIENT'S CATALOG NUMBER	
	AD-A105 280		
4. TITLE (and Subtitle) Phase I Dam Inspection Report National Dam Safety Program Okaydy Reservoir Dam (MO 10001) Howard County, Missouri		5. TYPE OF REPORT & PERIOD COVERED Final Report	
7. AUTHOR(s) Hoskins-Western-Sonderegger, Inc.		6. PERFORMING ORG. REPORT NUMBER	
9. PERFORMING ORGANIZATION NAME AND ADDRESS U.S. Army Engineer District, St. Louis Dam Inventory and Inspection Section, LMSED-PD 210 Tucker Blvd., North, St. Louis, Mo. 63101		8. CONTRACT OR GRANT NUMBER(s) DACW43-79-C-0046	
11. CONTROLLING OFFICE NAME AND ADDRESS U.S. Army Engineer District, St. Louis Dam Inventory and Inspection Section, LMSED-PD 210 Tucker Blvd., North, St. Louis, Mo. 63101		10. PROGRAM ELEMENT, PROJECT, TASK AREA & WORK UNIT NUMBERS	
14. MONITORING AGENCY NAME & ADDRESS (if different from Controlling Office) Key S. / Gordon G. / Jamison 11 M. Mark		12. REPORT DATE June 1979	
		13. NUMBER OF PAGES Approximately 70	
		15. SECURITY CLASS. (of this report) UNCLASSIFIED	
16. DISTRIBUTION STATEMENT (of this Report) Approved for release; distribution unlimited.		15a. DECLASSIFICATION/DOWNGRADING SCHEDULE	
17. DISTRIBUTION STATEMENT (of the abstract entered in Block 20, if different from Report) National Dam Safety Program. Okaydy Reservoir Dam (MO 10001) Missouri - Kansas City Basin, Howard County Missouri. Phase I Inspection report.			
18. SUPPLEMENTARY NOTES			
19. KEY WORDS (Continue on reverse side if necessary and identify by block number) Dam Safety, Lake, Dam Inspection, Private Dams			
20. ABSTRACT (Continue on reverse side if necessary and identify by block number) This report was prepared under the National Program of Inspection of Non-Federal Dams. This report assesses the general condition of the dam with respect to safety, based on available data and on visual inspection, to determine if the dam poses hazards to human life or property.			

DD FORM 1 JAN 73 1473

EDITION OF 1 NOV 65 IS OBSOLETE

UNCLASSIFIED

SECURITY CLASSIFICATION OF THIS PAGE (When Data Entered)

311/231

SECURITY CLASSIFICATION OF THIS PAGE(When Data Entered)

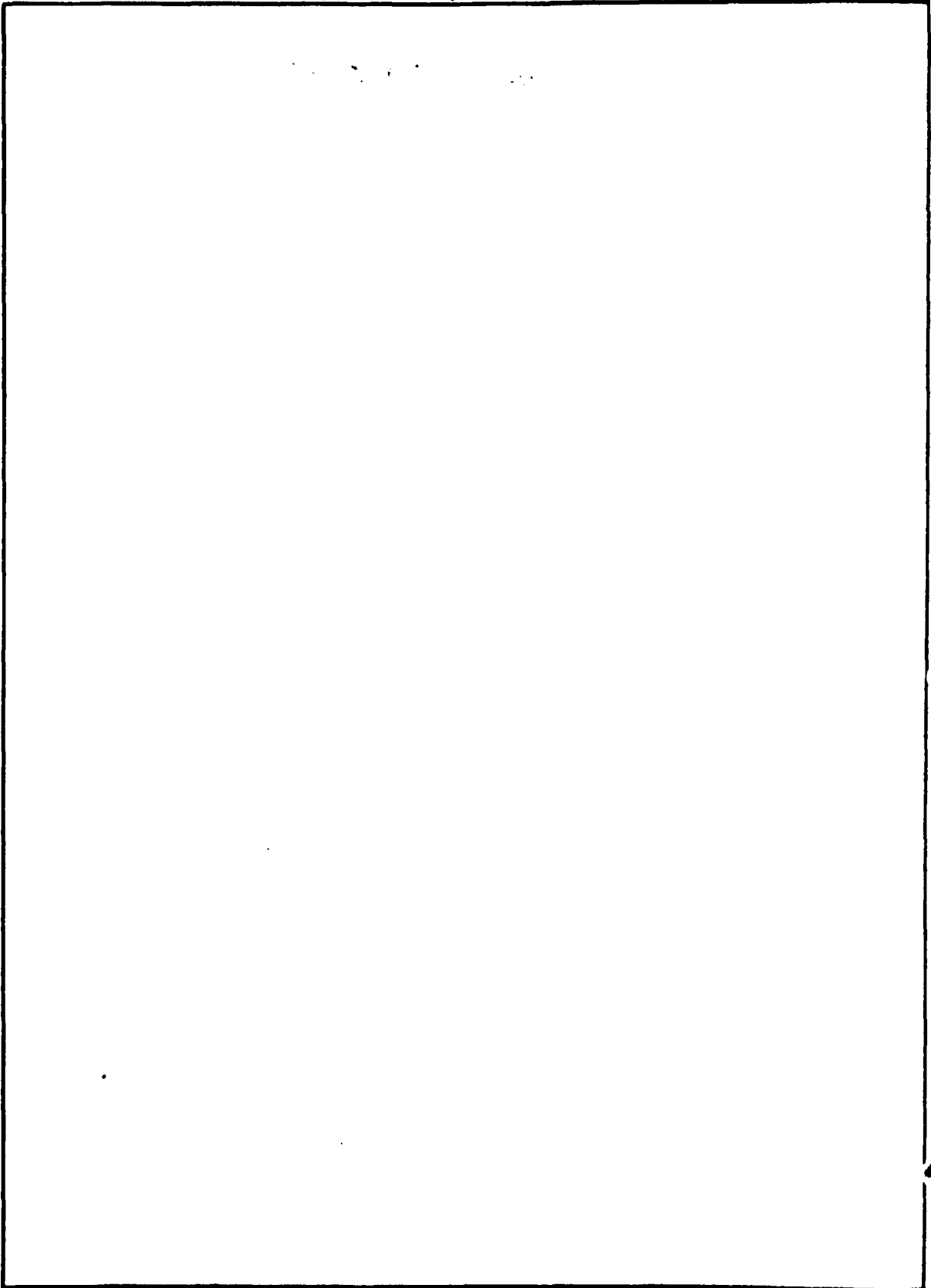

SECURITY CLASSIFICATION OF THIS PAGE(When Data Entered)

## INSTRUCTIONS FOR PREPARATION OF REPORT DOCUMENTATION PAGE

**RESPONSIBILITY.** The controlling DoD office will be responsible for completion of the Report Documentation Page, DD Form 1473, in all technical reports prepared by or for DoD organizations.

**CLASSIFICATION.** Since this Report Documentation Page, DD Form 1473, is used in preparing announcements, bibliographies, and data banks, it should be unclassified if possible. If a classification is required, identify the classified items on the page by the appropriate symbol.

### COMPLETION GUIDE

**General.** Make Blocks 1, 4, 5, 6, 7, 11, 13, 15, and 16 agree with the corresponding information on the report cover. Leave Blocks 2 and 3 blank.

**Block 1.** Report Number. Enter the unique alphanumeric report number shown on the cover.

**Block 2.** Government Accession No. Leave Blank. This space is for use by the Defense Documentation Center.

**Block 3.** Recipient's Catalog Number. Leave blank. This space is for the use of the report recipient to assist in future retrieval of the document.

**Block 4.** Title and Subtitle. Enter the title in all capital letters exactly as it appears on the publication. Titles should be unclassified whenever possible. Write out the English equivalent for Greek letters and mathematical symbols in the title (*see "Abstracting Scientific and Technical Reports of Defense-sponsored RDT/E," AD-667 000*). If the report has a subtitle, this subtitle should follow the main title, be separated by a comma or semicolon if appropriate, and be initially capitalized. If a publication has a title in a foreign language, translate the title into English and follow the English translation with the title in the original language. Make every effort to simplify the title before publication.

**Block 5.** Type of Report and Period Covered. Indicate here whether report is interim, final, etc., and, if applicable, inclusive dates of period covered, such as the life of a contract covered in a final contractor report.

**Block 6.** Performing Organization Report Number. Only numbers other than the official report number shown in Block 1, such as series numbers for in-house reports or a contractor/grantee number assigned by him, will be placed in this space. If no such numbers are used, leave this space blank.

**Block 7.** Author(s). Include corresponding information from the report cover. Give the name(s) of the author(s) in conventional order (for example, *John R. Doe or, if author prefers, J. Robert Doe*). In addition, list the affiliation of an author if it differs from that of the performing organization.

**Block 8.** Contract or Grant Number(s). For a contractor or grantee report, enter the complete contract or grant number(s) under which the work reported was accomplished. Leave blank in in-house reports.

**Block 9.** Performing Organization Name and Address. For in-house reports enter the name and address, including office symbol, of the performing activity. For contractor or grantee reports enter the name and address of the contractor or grantee who prepared the report and identify the appropriate corporate division, school, laboratory, etc., of the author. List city, state, and ZIP Code.

**Block 10.** Program Element, Project, Task Area, and Work Unit Numbers. Enter here the number code from the applicable Department of Defense form, such as the DD Form 1498, "Research and Technology Work Unit Summary" or the DD Form 1634, "Research and Development Planning Summary," which identifies the program element, project, task area, and work unit or equivalent under which the work was authorized.

**Block 11.** Controlling Office Name and Address. Enter the full, official name and address, including office symbol, of the controlling office. (*Equates to funding/sponsoring agency. For definition see DoD Directive 5200.20, "Distribution Statements on Technical Documents."*)

**Block 12.** Report Date. Enter here the day, month, and year or month and year as shown on the cover.

**Block 13.** Number of Pages. Enter the total number of pages.

**Block 14.** Monitoring Agency Name and Address (*if different from Controlling Office*). For use when the controlling or funding office does not directly administer a project, contract, or grant, but delegates the administrative responsibility to another organization.

**Blocks 15 & 15a.** Security Classification of the Report: Declassification/Downgrading Schedule of the Report. Enter in 15 the highest classification of the report. If appropriate, enter in 15a the declassification/downgrading schedule of the report, using the abbreviations for declassification/downgrading schedules listed in paragraph 4-207 of DoD 5200.1-R.

**Block 16.** Distribution Statement of the Report. Insert here the applicable distribution statement of the report from DoD Directive 5200.20, "Distribution Statements on Technical Documents."

**Block 17.** Distribution Statement (*of the abstract entered in Block 20, if different from the distribution statement of the report*). Insert here the applicable distribution statement of the abstract from DoD Directive 5200.20, "Distribution Statements on Technical Documents."

**Block 18.** Supplementary Notes. Enter information not included elsewhere but useful, such as: Prepared in cooperation with . . . Translation of (or by) . . . Presented at conference of . . . To be published in . . .

**Block 19.** Key Words. Select terms or short phrases that identify the principal subjects covered in the report, and are sufficiently specific and precise to be used as index entries for cataloging, conforming to standard terminology. The DoD "Thesaurus of Engineering and Scientific Terms" (TEST), AD-672 000, can be helpful.

**Block 20.** Abstract. The abstract should be a brief (*not to exceed 200 words*) factual summary of the most significant information contained in the report. If possible, the abstract of a classified report should be unclassified and the abstract to an unclassified report should consist of publicly-releasable information. If the report contains a significant bibliography or literature survey, mention it here. For information on preparing abstracts see "Abstracting Scientific and Technical Reports of Defense-Sponsored RDT&E," AD-667 000.

OKAYDY RESERVOIR DAM  
HOWARD COUNTY, MISSOURI  
MO. 10001

PHASE I INSPECTION REPORT  
NATIONAL DAM SAFETY PROGRAM

PREPARED BY  
HOSKINS-WESTERN-SONDEREGGER, INC.  
CONSULTING ENGINEERS  
LINCOLN, NEBRASKA

UNDER DIRECTION OF  
ST. LOUIS DISTRICT, CORPS OF ENGINEERS

FOR

GOVERNOR OF MISSOURI

JUNE, 1979

Accession For	
NTIS GRA&I	<input checked="" type="checkbox"/>
DTIC TAB	<input type="checkbox"/>
Unannounced	<input type="checkbox"/>
Justification	
By _____	
Distribution/	
Availability Codes	
Dist	Avail and/or Special
A	

DTIC  
FILE  
S OCT 9 1981 D



DEPARTMENT OF THE ARMY  
ST. LOUIS DISTRICT, CORPS OF ENGINEERS  
210 NORTH 12TH STREET  
ST. LOUIS, MISSOURI 63101

IN REPLY REFER TO

SUBJECT: Okaydy Reservoir Dam Phase I Inspection Report

This report presents the results of field inspection and evaluation of the Okaydy Reservoir Dam:

It was prepared under the National Program of Inspection of Non-Federal Dams

This dam has been classified as unsafe, non-emergency by the St. Louis District as a result of the application of the following criteria:

- 1) Spillway will not pass the Probable Maximum Flood.
- 2) Overtopping could result in dam failure.
- 3) Dam failure significantly increases the hazard to loss of life downstream.

SUBMITTED BY:	<u>SIGNED</u>	<u>20 DEC 1979</u>
	Chief, Engineering Division	Date
APPROVED BY:	<u>SIGNED</u>	<u>20 DEC 1979</u>
	Colonel, CE, District Engineer	Date

PHASE I INSPECTION REPORT  
NATIONAL DAM SAFETY PROGRAM

TABLE OF CONTENTS

<u>PARAGRAPH NO.</u>	<u>TITLE</u>	<u>PAGE NO.</u>
	Assessment Summary	
	Overview Photograph	
SECTION 1 - PROJECT INFORMATION		
1.1	General	1
1.2	Description of Project	1
1.3	Pertinent Data	2
SECTION 2 - ENGINEERING DATA		
2.1	Design	5
2.2	Construction	5
2.3	Operation	5
2.4	Evaluation	5
SECTION 3 - VISUAL INSPECTION		
3.1	Findings	6
3.2	Evaluation	8
SECTION 4 - OPERATIONAL PROCEDURES		
4.1	Procedures	9
4.2	Maintenance of Dam	9
4.3	Maintenance of Operating Facilities	9
4.4	Description of Any Warning System in Effect	9
4.5	Evaluation	9
SECTION 5 - HYDRAULIC/HYDROLOGIC		
5.1	Evaluation of Features	10
SECTION 6 - STRUCTURAL STABILITY		
6.1	Evaluation of Structural Stability	12
SECTION 7 - ASSESSMENT/REMEDIAL MEASURES		
7.1	Dam Assessment	13
7.2	Remedial Measures	13

## APPENDIX A - MAPS

Plate A-1	Vicinity Topography
Plate A-2	Location Map

## APPENDIX B - PHOTOGRAPHS

Plate B-1	Photo Index	
Plate B-2	Photo No. 2	View of Upstream Slope From Right Abutment
	Photo No. 3	View of Crest From Right Abutment
Plate B-3	Photo No. 4	Downstream Slope From Right Abutment
	Photo No. 5	Eroded Upstream Face at Sta. 2 + 10 $\pm$
Plate B-4	Photo No. 6	Eroded Upstream Face at Sta. 1 + 20 $\pm$
	Photo No. 7	Crest of Spillway From Right Side
Plate B-5	Photo No. 8	View of Spillway Crest From Downstream in Spillway
	Photo No. 9	View Downstream in Spillway
Plate B-6	Photo No. 10	Downstream Slope From Left End. Note Lone Tree
	Photo No. 11	Seep Along Toe at Left End
Plate B-7	Photo No. 12	Seep in Right Abutment Trough Below Toe
	Photo No. 13	View Across Reservoir From Sta. 4 + 50
Plate B-8	Photo No. 14	View Downstream From Sta. 4 + 50
	Photo No. 15	Overview From Right Abutment

## APPENDIX C - PROJECT PLATES

Plate C-1	Phase I - Plan and Centerline Profile of Dam
Plate C-2	Phase I - Section of Dam and Profile of Emergency Spillway

## APPENDIX D - HYDRAULIC AND HYDROLOGIC DATA

Plates D-1 & D-2	Hydrologic Computations
Plate D-3	Spillway Rating Curve
Plate D-4	PMF Routings
Plates D-5 to D-16	Computer Input and Output for PMF

PHASE I REPORT  
NATIONAL DAM SAFETY PROGRAM  
ASSESSMENT SUMMARY

Name of Dam	Okaydy Reservoir Dam
State Located	Missouri
County Located	Howard County
Stream	Cottonwood Creek
Date of Inspection	June 1, 1979

Okaydy Reservoir Dam was inspected by an interdisciplinary team of engineers from Hoskins-Western-Sonderregger, Inc. The purpose of the inspection was to make an assessment of the general condition of the dam with respect to safety, based upon available data and visual inspection, in order to determine if the dam poses hazards to human life or property.

The guidelines used in the assessment were furnished by the Department of the Army, Office of the Chief of Engineers, and developed with the help of several Federal and State agencies, professional engineering organizations, and private engineers. Based on these guidelines, this dam is classified as a small size dam with a high downstream hazard potential. Failure would threaten life and property. The estimated damage zone extends approximately one-half mile (and at this point enters Missouri River floodplain) downstream of the dam. Within the one-half mile damage zone is the town of Franklin with approximately 70 dwellings.

Our inspection and evaluation indicates that the spillway does not meet the criteria set forth in the recommended guidelines for a small dam having a high hazard potential. Due to the close proximity of the town of Franklin and the number of dwellings the Probable Maximum Flood is the appropriate spillway design flood. The spillway will pass the 100-year flood (flood having a one percent chance of being exceeded in any year) without overtopping the dam. The spillway will pass 25% of the Probable Maximum Flood without overtopping the dam. The Probable Maximum Flood (PMF) is defined as the flood that may be expected from the most severe combination of critical meteorologic and hydrologic conditions that are reasonably possible in the region.

No design data were available for this dam. Seepage and stability analyses comparable to the requirements of the "Recommended Guidelines for Safety Inspection of Dams" were not available, which is considered a deficiency. These analyses should be obtained in the future.

Other deficiencies noted during the inspection are erosion of the upstream face at two locations, trees and shrubs growing along the waterline, seepage along the downstream toe from the left end to the right abutment trough, inlet sill of spillway blocked by beaver dam, small trees and brush growing on reservoir side of inlet sill, and downstream channel from spillway is overgrown with trees and brush.

Maintenance is, in general, good. Several items of preventative maintenance are more specifically covered in the body of the report.

Rey S. Decker  
Rey S. Decker  
E-3703

Gordon G. Jamison  
Gordon Jamison

Michael M. Meekin  
Michael McMeekin  
E-4776

H. P. Hoskins  
Harold P. Hoskins  
Chairman of Board  
Hoskins-Western-Sonderegger, Inc.  
E-8696



PHOTO NO. 1 - OVERVIEW. DAM TO LEFT OF CENTER.

PHASE I INSPECTION REPORT  
NATIONAL DAM SAFETY PROGRAM  
OKAYDY RESERVOIR DAM - MO 10001  
HOWARD COUNTY, MISSOURI

SECTION 1 - PROJECT INFORMATION

1.1 GENERAL

- a. Authority. The National Dam Inspection Act, Public Law 92-367, authorized the Secretary of the Army, through the Corps of Engineers, to initiate a program of safety inspection of dams throughout the United States. Pursuant to the above, the St. Louis District, Corps of Engineers, District Engineer directed that a safety inspection of Okaydy Reservoir Dam be made.
- b. Purpose of Inspection. The purpose of the inspection was to make an assessment of the general condition of the dam with respect to safety, based upon available data and visual inspection, in order to determine if the dam poses hazards to human life or property.
- c. Evaluation Criteria. Criteria used to evaluate the dam were furnished by the Department of the Army, Office of the Chief of Engineers, in "Recommended Guidelines for Safety Inspection of Dams", Appendix D to "Report of the Chief of Engineers on the National Program of Inspection of Dams", dated May, 1975, and published by the Department of the Army, Office of the Chief of Engineers.

1.2 DESCRIPTION OF PROJECT

- a. Description of Dam and Appurtenances.
  - (1) The dam is an earth fill approximately 580 feet long and 23 feet ± in height. It is located in the deep loess hills of the Central Mississippi Valley physiographic area. It is one of two dams on the University of Missouri Franklin Horticultural Farm.
  - (2) The spillway consists of a channel excavated through the left abutment. It is lined with concrete rubble masonry with three concrete transverse sills. It has a bottom width of about 50 feet.

(3) Pertinent physical data are given in paragraph 1.3 below.

- b. Location. The dam is located in the south central portion of Howard County, Missouri, as shown on Plate A-2. The dam is shown on Plate A-1 in the NW $\frac{1}{4}$  of Section 29, T49N, R16W.
- c. Size Classification. Criteria for determining the size classification of dams and impoundments are presented in the guidelines referenced in paragraph 1.1c above. Based on these criteria, this dam and impoundment is in the small size category.
- d. Hazard Classification. Guidelines for determining hazard classification are presented in the same guidelines as referenced in paragraph 1.1c above. Based on referenced guidelines, this dam is in the High Hazard Classification. The estimated damage zone extends into the town of Franklin, approximately 0.3 mile downstream from the dam. Within the damage zone are about 70 dwellings which could be affected.
- e. Ownership. The dam is owned by the University of Missouri, Room I-43, Agricultural Building, Columbia, Missouri 65211. Attention: Dr. Donald Hegwood.
- f. Purpose of Dam. The dam impounds water originally used by the MKT Railroad. It now provides some flood protection for Franklin and supplemental irrigation water for the University of Missouri Franklin Horticultural Farm.
- g. Design and Construction History. The dam was built by the MKT Railroad in 1904. The height of the dam was increased about 5 feet and the downstream slope flattened in 1954. Material for the additional construction was CL loess borrowed from the adjacent hills. The spillway was modified and improved in 1927. It was reported by Dr. Audrie Hibbard of the University of Missouri that the lake is silted in to about one-half the original capacity.
- h. Normal Operating Procedure. There are no operating facilities for this dam.

### 1.3 PERTINENT DATA

- a. Drainage Area. 2.19 square miles (1,403 acres)
- b. Discharge at Damsite.
  - (1) All discharges at the damsite are through the concrete rubble masonry spillway channel.

- (2) Estimated maximum flood - unknown.
- (3) The spillway capacity varies from 0 cfs at its crest elevation to 1,600 cfs at elevation 620.9 (minimum top of dam).
- c. Elevations. (Feet above M.S.L.).
  - (1) Top of dam - 620.9 (minimum)
  - (2) Spillway crest - 615.0
  - (3) Streambed at centerline - 598 ±
  - (4) Maximum tailwater - unknown.
- d. Reservoir. Length (feet) of maximum pool - 6,500 ±
- e. Storage (Acre-feet).
  - (1) Top of dam - 370 ±
  - (2) Principal spillway crest - 53 ±
- f. Reservoir Surface (Acres).
  - (1) Top of dam - 65 ±
  - (2) Principal spillway crest - 32 ±
- g. Dam.
  - (1) Type - earth fill
  - (2) Length - 580 feet ±
  - (3) Height - 23 feet ±
  - (4) Top width - 12 feet ±
  - (5) Side slopes.
    - (a) Downstream - upper 5 feet = 1.3H on 1V; 2.8H on 1V below this.
    - (b) Upstream - 2.2H on 1V from crest to elevation 618 ft. ± then near vertical to water line
  - (6) Zoning - unknown
  - (7) Impervious core - unknown
  - (8) Cutoff - unknown
  - (9) Grout curtain - unknown
  - (10) Wave protection - some old concrete slabs and rubble.
  - (11) Internal drainage - unknown
- h. Diversion Channel and Regulating Tunnel. None
- i. Spillway.
  - (1) Principal
    - (a) Type - excavated earth channel lined with concrete rubble masonry

- (b) Crest elevation - concrete sill = 615 feet  
Outlet - end of rubble masonry channel = 605 feet ± where it drops vertically to streambed
- (c) Length - 52 feet ±, upper one-half on 13.7% slope, lower one-half on slope = 24.4%
- (d) Upstream Channel - excavated earth
- (e) Downstream Channel - natural creek bed

j. Regulating Outlets. None

## SECTION 2 - ENGINEERING DATA

### 2.1 DESIGN

- a. No design data were available for this dam.

### 2.2 CONSTRUCTION

- a. No construction data were available. It was reported by Dr. Audrie Hibbard of the University of Missouri that the dam was built in 1904 by the MKT Railroad. The University of Missouri raised the dam and modified the downstream slope in 1954. The spillway was rebuilt in 1927.

### 2.3 OPERATION

- a. No data were available on spillway operation. It was reported by Dr. Hibbard that spillway flows approached the maximum capacity in 1955 after a 5-inch rain.

### 2.4 EVALUATION

- a. Availability. No data were available.
- b. Adequacy. The field surveys and visual observations presented herein are considered adequate to support the conclusions of this report. Seepage and stability analyses comparable to the requirements of the "Recommended Guidelines for Safety Inspection of Dams" were not available, which is considered a deficiency. These seepage and stability analyses should be performed for appropriate loading conditions (including earthquake loads) and made a matter of record.
- c. Validity. Not applicable.

## SECTION 3 - VISUAL INSPECTION

### 3.1 FINDINGS

- a. General. A visual inspection of the Okaydy Dam was made on June 1, 1979. Engineers from Hoskins-Western-Sonderegger, Inc., Lincoln, Nebraska making the inspection were: R.S. Decker, Geotechnical; Gordon Jamison, Hydrology; and Mike McMeekin, Civil Engineer. Mr. Herb Biesemeyer, Farm Manager for the University of Missouri, accompanied the inspection team. Dr. Audrie Hibbard of the University of Missouri was interviewed in Columbia prior to the inspection.
- b. Dam.
- (1) Geology and Soils (abutment and embankment). This dam is located in the Central Mississippi Valley wooded slope soil association area. Soils on the uplands and slopes (abutments) consist of deep CL loess materials. Soils in the valley (foundation) consist of CL alluvium overlying glacial till (probably Kansan) or limestone/shale bedrock. No till or bedrock outcrops were observed at the site.
  - (2) Upstream Slope. The upstream face slopes on 2.2 to 2.5H on 1V from the crest elevation down about 3 feet (elev. 618 feet  $\pm$ ) where it breaks to near vertical to the water surface at elevation 615.2 feet. Some riprap consisting of old concrete slabs and rubble was observed at or just above the water line. The slope above the riprap is fairly well vegetated with grass. A few small trees and shrubs are growing along the water line. Some erosion is noticeable above the riprap and two areas near Stations 2 + 10 and 1 + 20, show significant erosional damage with material removed almost to the crestline (see Photos 5 and 6).
  - (3) Crest - The crest is well vegetated with adapted grasses and was recently mowed. One large tree is growing on the downstream crest line near station 2 + 00. This tree was evidently left in place when the dam was enlarged in 1954. The profile of the crest is fairly uniform with one slight depressional area (0.3 to 0.5 ft. low) around Station 2 + 00. No cracks, rodent holes or lateral deformations were noted.

- (4) Downstream Slope. The downstream slope is very well vegetated with adapted grasses. The upper 5 or 6 feet of the slope is much steeper (1.3H to 1V) than the remainder of the slope (2.8H to 1V). This probably reflects the construction that was done in 1954 when the height of the dam was increased. No other abnormal deformations, cracks, slumps or rodent holes were observed on the slope. Seepage outcrops along and out from the toe of the dam from the left end to the right abutment trough (downstream from about Stations 0 + 00 to 4 + 00). All seepage is clear and ponded (not flowing) along the toe. No boils were observed along the toe nor was there any evidence of the phreatic surface outcropping on the slope. Total seepage effluent was estimated at less than 0.5 gal/min if it had been collected and channeled. It was reported by Dr. Hibbard that the amount of seepage is reducing each year (probably the result of sedimentation in the reservoir).
- (5) Miscellaneous. Borings on the dam indicate CL-CH materials to a depth of 2 feet. However, the erosion noted on the upstream face would indicate that at least some sections of the dam are not too resistant to erosion. With the excellent vegetative cover and the apparent CL-CH soils in the downstream section it would appear that the dam could withstand minor overtopping (less than 1 foot) without completely breaching the dam.

c. Appurtenant Structures.

- (1) The spillway is lined with rubble masonry and has 3 transverse concrete stabilizing sills, one at the inlet crest, one downstream about midway and one at the end of the masonry lining. The lining and the sills look good with no significant deterioration. A low beaver dam extends across the inlet sill structure so that the reservoir level was slightly higher than the spillway crest elevation. Several small trees and shrubs are growing across the inlet to the spillway.
- (2) Drawdown Facilities. It was reported by Dr. Hibbard that an 8 inch steel pipe line extends under the embankment to the railroad shops in Franklin, but it is now inoperable. Location of this pipe could not be determined. No other drawdown facilities exist.

- d. Reservoir Area. Some erosion is evident around the shoreline of the reservoir, particularly around the left (north) side. However, no slides or slumps were observed.
- e. Downstream Channel. The channel downstream from the spillway outlet is badly overgrown with trees and shrubs.

### 3.2 EVALUATION

- a. This dam appears to be in good shape with the exception of minor deficiencies in controlling vegetation and erosion on the upstream slope. The slope and the apparent materials in the downstream section should provide adequate safety against shear failure for a dam of this height. Seepage along the toe does not appear to affect the safety of the structure but is considered a deficiency that should be investigated.

## SECTION 4 - OPERATIONAL PROCEDURES

### 4.1 PROCEDURES

- a. There are no controlled outlet works for this dam. The pool level is controlled by rainfall, evaporation, seepage, and the capacity of the uncontrolled spillway.

### 4.2 MAINTENANCE OF DAM

- a. In general, maintenance of the dam and spillway appears to be good. Tree growth and erosion on the upstream face should be controlled, but it is doubtful that the one large tree on the crest will cause any significant damage to the dam.

### 4.3 MAINTENANCE OF OPERATING FACILITIES

- a. No operating facilities exist at this dam.

### 4.4 DESCRIPTION OF ANY WARNING SYSTEM IN EFFECT

- a. Upon checking with the owner we are unaware of any warning system in effect for this dam.

### 4.5 EVALUATION

- a. There does not appear to be any serious potential of failure of this structure.

## SECTION 5 - HYDRAULIC/HYDROLOGIC

### 5.1 EVALUATION OF FEATURES

- a. Design Data. No design data were available for Okaydy Reservoir Dam.
- b. Experience. There are no available records of reservoir operation or frequency of spillway operation.
- c. Visual Observations. The spillway consists of a 50-foot wide channel surfaced with concrete rubble masonry. There are 3 transverse concrete sills across the spillway channel. The upstream control sill is clogged by a beaver dam and several trees and shrubs growing along the crest. As a result, the reservoir water surface elevation is approximately 0.2' above the spillway crest. From the third transverse sill (end sill) downstream, the spillway channel is almost completely choked with trees and shrubs.
- d. Overtopping Potential. According to the guidelines of the Department of the Army, Office of the Chief of Engineers, Okaydy Reservoir Dam is classified as having a high hazard rating and a small size. One half of the Probable Maximum Flood (PMF) to the PMF, therefore, is the recommended design flood for evaluation of the adequacy of the dam and its spillway.

The existing spillway will not pass 1/2 of the PMF or the PMF without overtopping of the dam. The spillway will pass the 100-year flood and approximately 25% of the PMF without overtopping. The dam could probably stand minor overtopping (less than 1 foot) without completely breaching the dam.

The results of the routings are tabulated below:

<u>Flood</u>	<u>Inflow Discharge c.f.s.</u>	<u>Outflow Discharge c.f.s.</u>	<u>Maximum Pool Elevation</u>	<u>Freeboard Top of Dam Min. Elev. 620.9</u>	<u>Time Dam Overtopping Hr.</u>
100 yr.	2,480	1,220	620.0	0.9'	0
0.50 PMF	5,260	4,970	622.7	-1.8'	4 <sup>±</sup>
PMF	10,530	10,240	623.9	-3.0'	7 <sup>±</sup>
0.25 PMF	2,600	1,600*	620.9	0.0	0

\*Maximum spillway discharge

The drainage area of the Okaydy Reservoir Dam watershed was determined from the U.S.G.S. Franklin, Mo. and New Franklin, Mo. 7 1/2-minute topographic quadrangle maps. Reservoir surface area and elevation-storage data were determined from the Franklin quadrangle map. Computations for spillway and dam overtopping discharge ratings were based on surveys made during the field inspection. Hydraulic and hydrologic computations are described in Appendix D.

The estimated downstream damage zone is described in Paragraph 1.2d of this report.

## SECTION 6 - STRUCTURAL STABILITY

### 6.1 EVALUATION OF STRUCTURAL STABILITY

- a. Visual Observation. This dam appears to be structurally stable. The downstream slope, although steeper than normal in the upper section, should be stable against shear failures. Seepage along the toe does not appear to be critical but its effect on stability should be investigated and evaluated.

Analyses presented in Section 5 indicate that the dam will be overtopped by the Probable Maximum Flood by about 3.0 feet for 7 hours. The effects of such overtopping are not known.

- b. Design and Construction Data. No design or construction data were available. Seepage and stability analyses comparable to the requirements of the "Recommended Guidelines for Safety Inspection of Dams" were not available, which is considered a deficiency. These seepage and stability analyses should be performed for appropriate loading conditions (including earthquake loads) and made a matter of record.
- c. Operating Records. There are no controlled operating facilities for this dam.
- d. Post Construction Changes. It was reported by Dr. Audrie Hibbard that the dam was raised 5 or 6 feet and the downstream slope was flattened in 1954. The spillway was rebuilt in 1927.
- e. Seismic Stability. This dam is located in Seismic Zone 1. An earthquake of the magnitude predicted in this area is not expected to cause structural failure of this dam.

## SECTION 7 - ASSESSMENT/REMEDIAL MEASURES

### 7.1 DAM ASSESSMENT

- a. Safety. There does not appear to be a serious potential of failure of this structure. Floods exceeding 25% of the maximum design flood (PMF) will overtop the dam. Seepage along the toe of the dam is considered a deficiency. It is not known whether or not some of the seepage could be caused by leaks in the old water supply line which traverses the base of the dam. Additional studies would be required to determine the effects of such overtopping on the structural and erosional stability of the dam and the source of seepage and its effects on the structural stability of the dam.
- b. Adequacy of Information. Due to the lack of engineering data, the conclusions in this report are based upon performance history and visual observations. Seepage and stability analyses comparable to the requirements of the "Recommended Guidelines for Safety Inspection of Dams" were not available, which is considered a deficiency.
- c. Urgency. The items recommended in paragraph 7.2.a relative to overtopping should be pursued on a high priority basis.
- d. Necessity for Phase II. Phase II investigation is not considered necessary.
- e. Seismic Stability. The dam is located in Seismic Zone 1. An earthquake of this magnitude is not expected to be hazardous to this dam.

### 7.2 REMEDIAL MEASURES

- a. Alternatives. (1) Additional information should be obtained on the topographic characteristics of the reservoir area to determine the increase in the height of dam or the size of the spillway that is necessary to pass the Probable Maximum Flood without overtopping the dam, (2) The source of the seepage along the downstream toe should be determined with particular reference to possible leakage from the old water supply line, (3) The services of an engineer experienced in the design of dams should be obtained to evaluate the present reservoir storage capacity, to provide seepage and stability analyses of the present dam, and to design protective measures, if required.

b. O & M Procedures.

- (1) Trees and shrubs should be removed from the upstream face of the dam and measures taken to prevent their recurrence.
- (2) The beaver dam, trees, and shrubs should be removed from the inlet of the spillway.
- (3) Obstructions (trees, etc.) should be removed from the outlet channel of the spillway to the extent that the spillway will operate effectively under the design flood.
- (4) Erosion on the upstream face should be corrected and measures taken to stabilize the slope with riprap or other means.
- (5) A program of regular inspection and maintenance should be initiated to control vegetative growth and erosion on the embankment slopes and to eliminate or control the beaver activity.

APPENDIX A  
MAPS



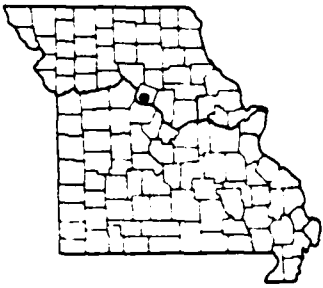
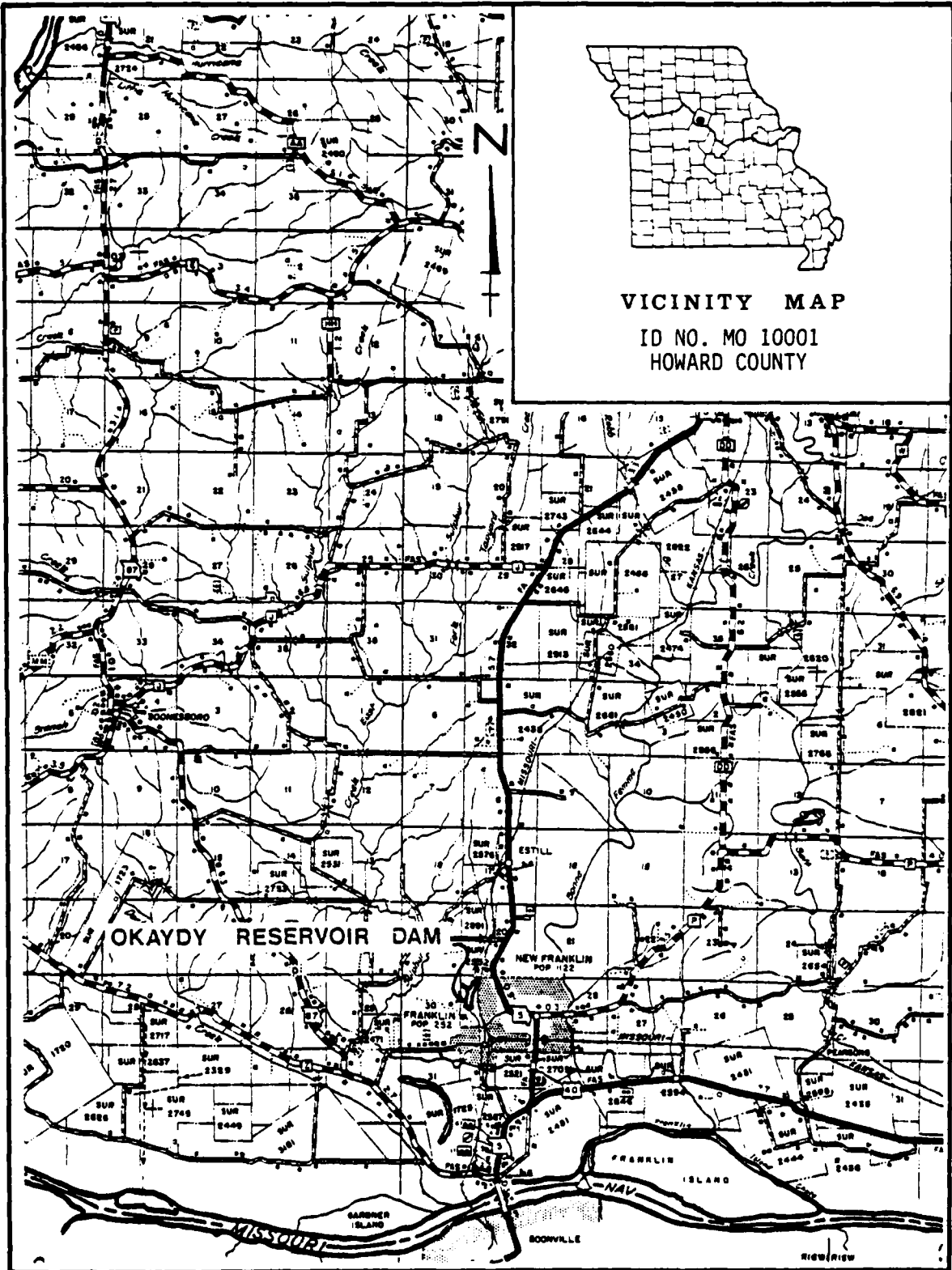

VICINITY MAP  
 ID NO. MO 10001  
 HOWARD COUNTY

OKAYDY RESERVOIR DAM

NEW FRANKLIN  
 POP 122

FRANKLIN  
 POP 232

Scale in miles

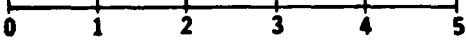

LOCATION MAP  
 PLATE A-2

APPENDIX B  
PHOTOGRAPHS

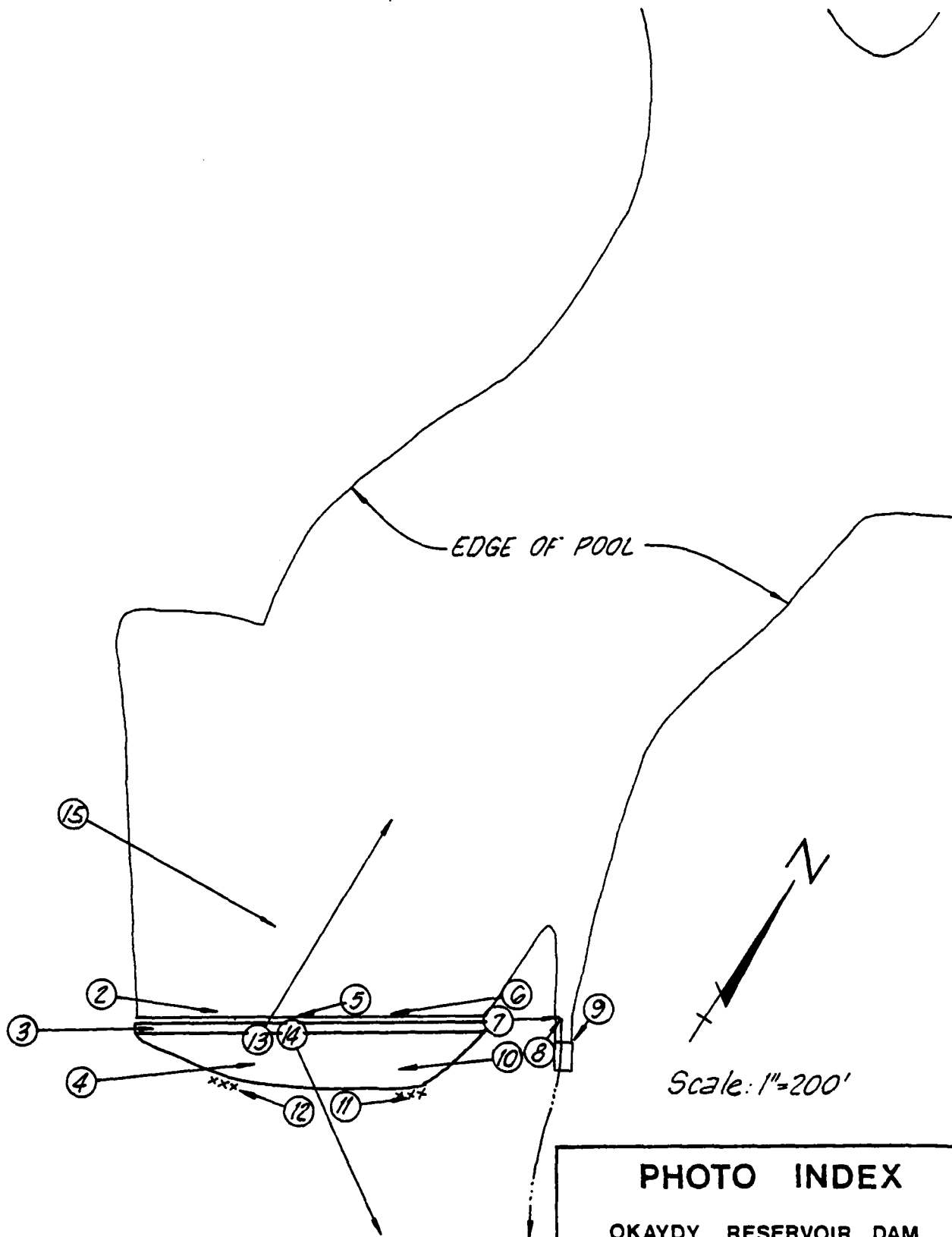

**PHOTO INDEX**

OKAYDY RESERVOIR DAM  
 HOWARD COUNTY, MISSOURI  
 MO. 10001 PLATE B-1



PHOTO NO. 2 - VIEW OF UPSTREAM SLOPE FROM RIGHT ABUTMENT.



PHOTO NO. 3 - VIEW OF CREST FROM RIGHT ABUTMENT.



PHOTO NO. 4 - DOWNSTREAM SLOPE FROM RIGHT ABUTMENT.



PHOTO NO. 5 - ERODED UPSTREAM FACE AT STA. 2 + 10.



PHOTO NO. 6 - ERODED UPSTREAM FACE AT STA. 1 + 20±.



PHOTO NO. 7 - CREST OF SPILLWAY FROM RIGHT SIDE.



PHOTO NO. 8 - VIEW OF SPILLWAY CREST FROM DOWNSTREAM IN SPILLWAY.



PHOTO NO. 9 - VIEW DOWNSTREAM IN SPILLWAY.



PHOTO NO. 10 - DOWNSTREAM SLOPE FROM LEFT END.  
NOTE LONE TREE.



PHOTO NO. 11 -  
SEEP ALONG TOE AT LEFT  
END.



PHOTO NO. 12 -

SEEP IN RIGHT ABUTMENT  
TROUGH BELOW TOE.



PHOTO NO. 13 - VIEW ACROSS RESERVOIR FROM STA. 4 + 50.



PHOTO NO. 14 - VIEW DOWNSTREAM FROM STA. 4 + 50.



PHOTO NO. 15 - OVERVIEW FROM RIGHT ABUTMENT.

APPENDIX C  
PROJECT PLATES

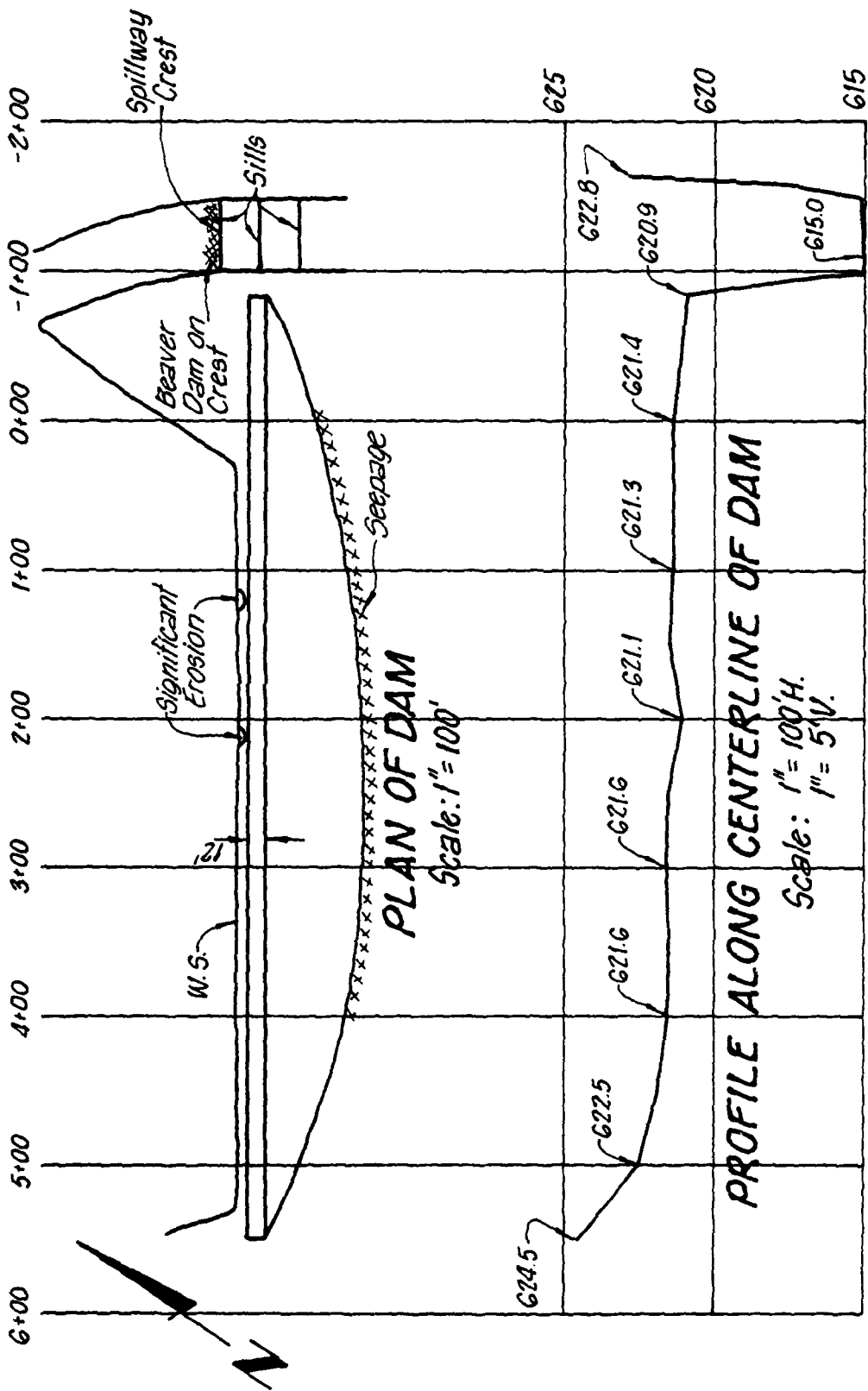
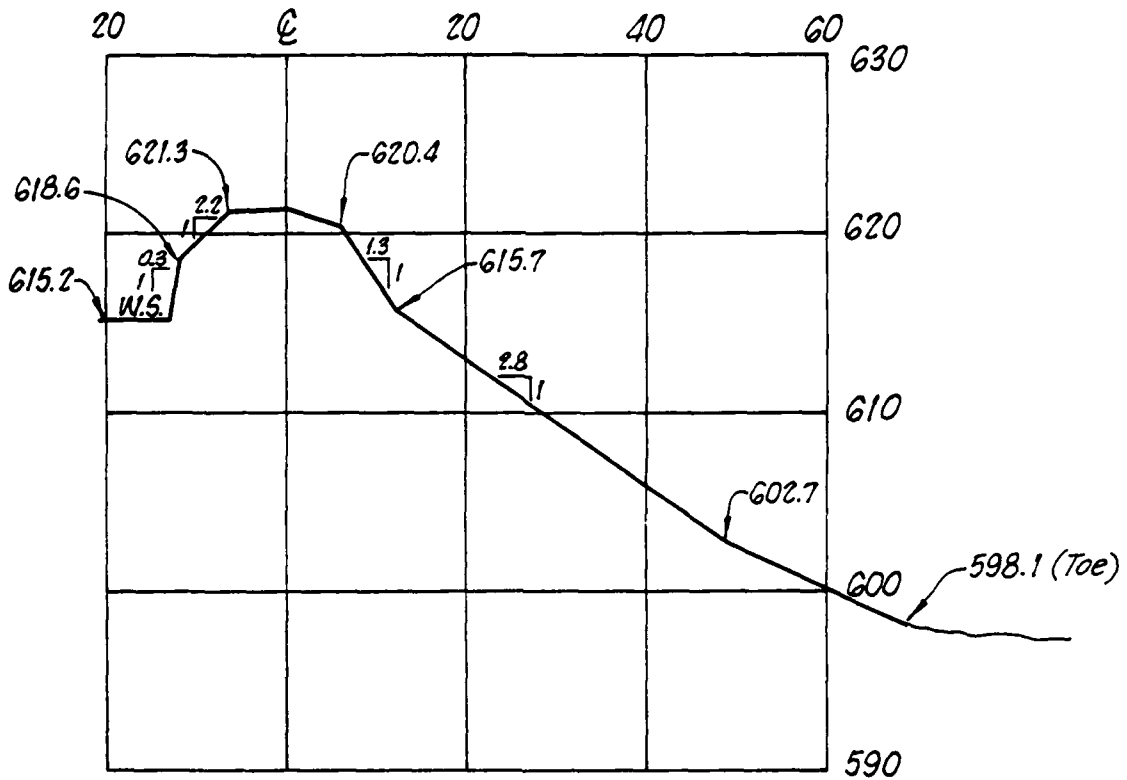
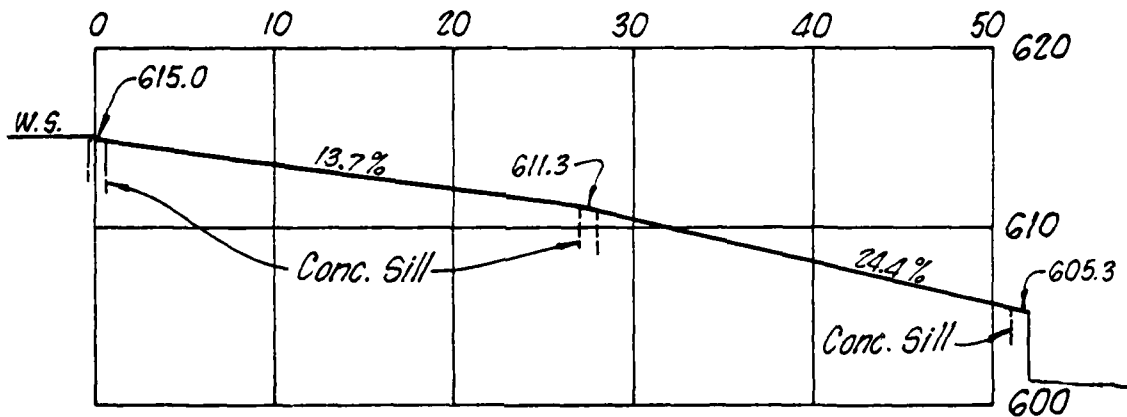

PLATE C-1



SECTION AT STA. 2+50

Scale: 1" = 20'H.  
1" = 5'V.



SPILLWAY PROFILE

Scale: 1" = 10'H.  
1" = 10'V.

APPENDIX D  
HYDRAULIC AND HYDROLOGIC DATA

## HYDROLOGIC COMPUTATIONS

1. The SCS dimensionless unit hydrograph and the systemized computer program HEC-1 (Dam Safety Version), July, 1978, prepared by the Hydrologic Engineering Center, U.S. Army Corps of Engineers, Davis, California, were used to develop the inflow hydrographs.
  - a. The 24-hour 100-year rainfall for the dam locations were taken from the data for the rainfall station at Jefferson City, Missouri, as supplied by the St. Louis District, Corps of Engineers, per their letter dated 6 March 1979. The 48-hour probable maximum precipitation was taken from the curves of Hydrometeorological Report No. 33 and current Corps of Engineers and St. Louis District policy and guidance for hydraulics and hydrology.
  - b. Drainage area = 2.19 square miles (1403 acres).
  - c. Time of concentration of runoff = 1.72 hours as computed by the Kirpich equation.
  - d. Antecedent moisture conditions for the probable maximum flood were assumed to be heavy rainfall and low temperatures for the previous five days (SCS AMC III). Antecedent moisture conditions for the 100-year flood were assumed to be an average of the conditions which have preceded the occurrence of the maximum annual flood on numerous watersheds (SCS AMC II).
  - e. Initial pool elevation was assumed to be at the spillway crest (elev. 615.0).
  - f. Total losses for the 24-hour 100-year storm were 2.57 inches. Total losses for the 48-hour PMP were 1.30 inches. The average loss rate for the 48-hour PMP was 0.03 inch per hour. Losses were determined using SCS CN 78 (AMC II) for the 24-hour, 100-year storm and SCS CN 90 (AMC III) for the PMP. Soils in the watershed are composed of approximately 59% SCS Soil Group B, 35% Soil Group C, and 6% Soil Group D. The soils in the watershed consist of Marshall, Menfro Sharpsburg, and Bremer (SCS soil group B); Gara and Armstrong (B and C); Ladoga, Lindley and Keswick (C); and Chariton (D). Land use in the watershed is approximately 80% cropland and 20% woods.
2. The discharge rating for the spillway was determined using the broad-crested weir equation. The discharge coefficient "C" was varied according to head and corrected for the effects of the downstream slope. (Reference: "Measurement of Peak Discharge

at Dams by Indirect Methods, U.S.G.S.). The discharge coefficient was also adjusted for the effects of the beaver dam and the small trees and brush which are clogging the crest. The resulting values for "C" ranged from 1.5 to 2.8. Head losses in the approach channel, which were computed using the HEC-2 computer program, were also included in the spillway rating.

The discharge rating for the dam crest was developed using the option of the HEC-1 (Dam Safety Version) program for flow over a non-level dam crest.

3. Floods were routed through the reservoir using the HEC-1 (Dam Safety Version) program. Input, output, and plotted hydrographs are included with this report.

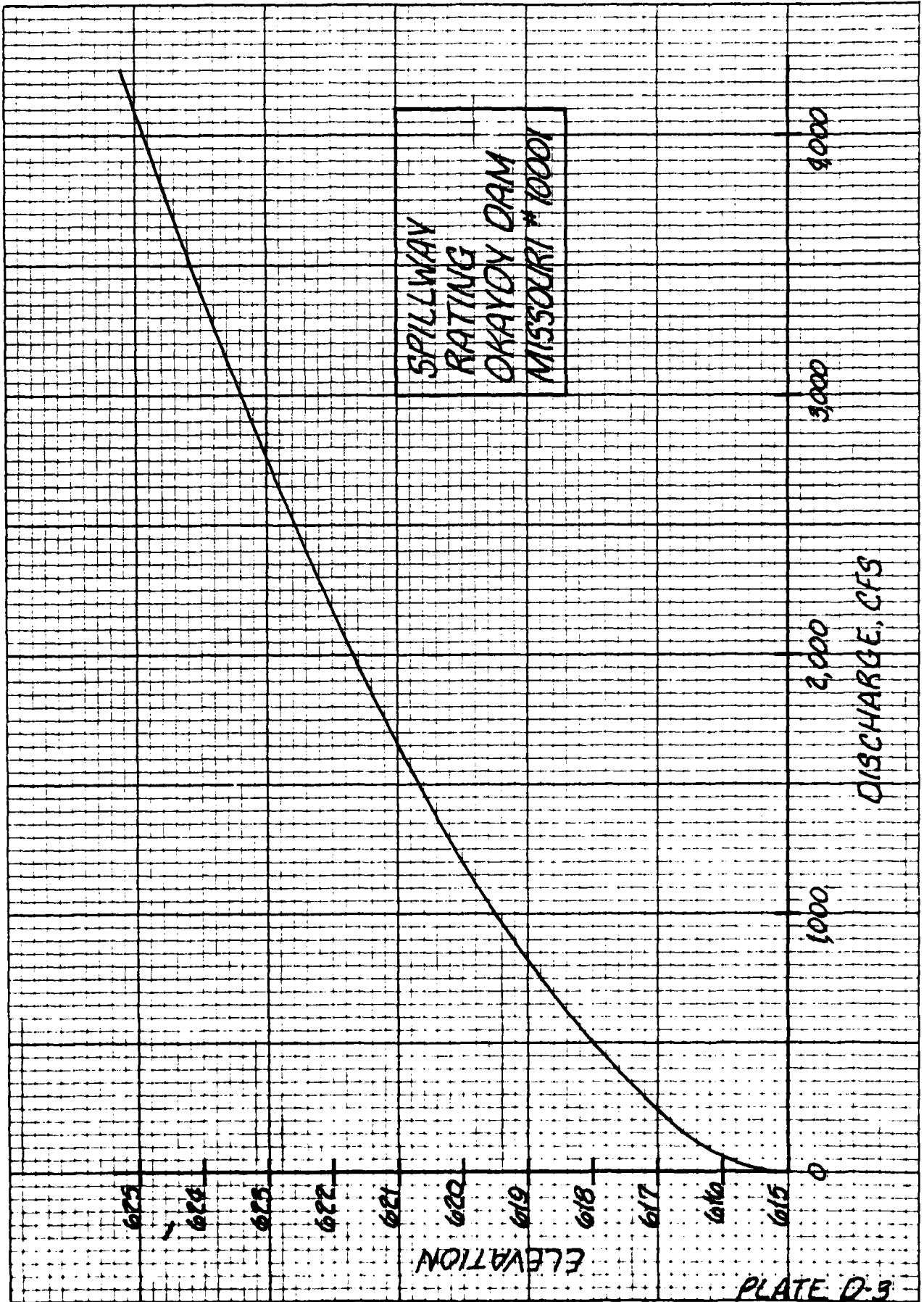

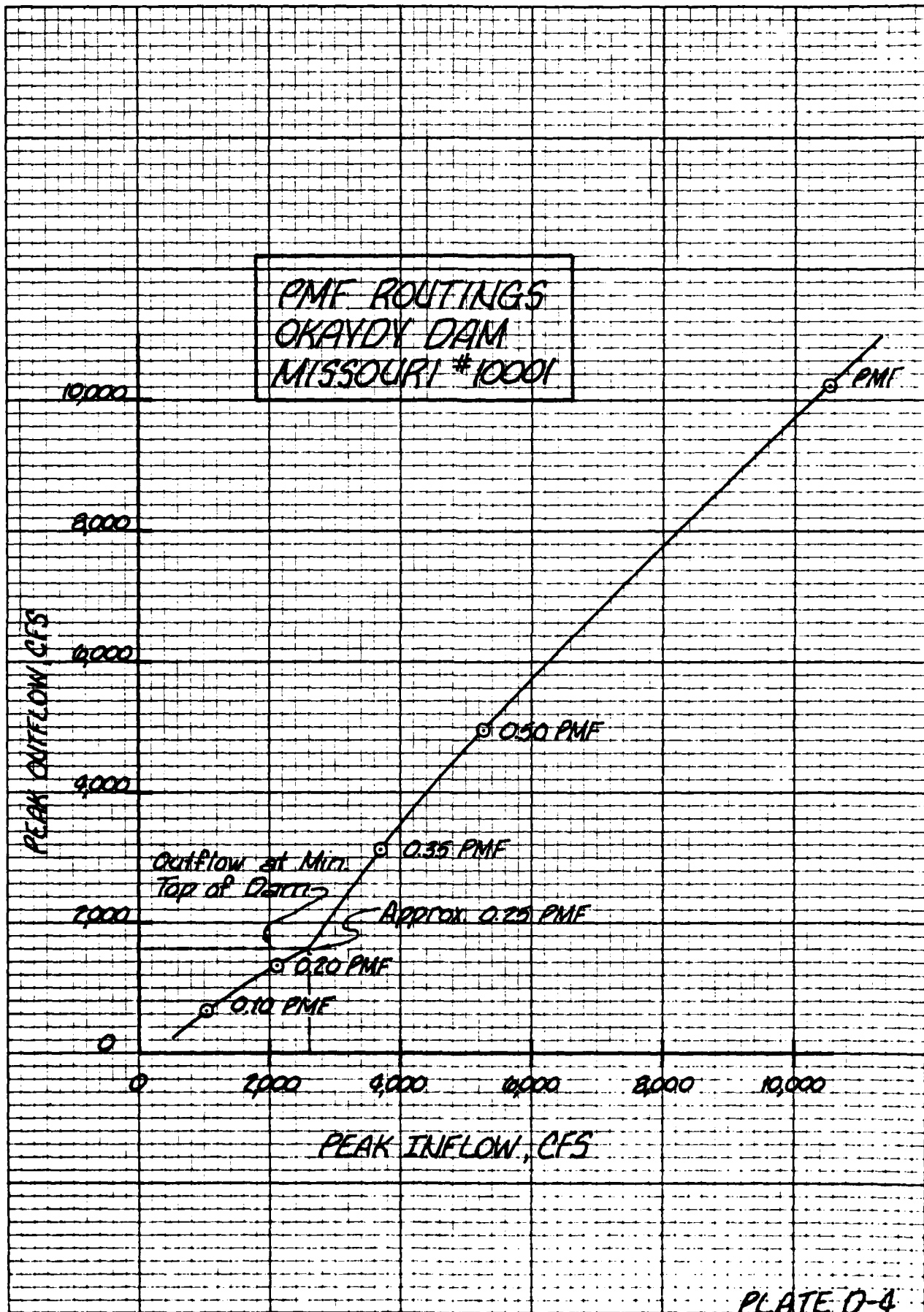



\*\*\*\*\*  
 FLOOD HYDROGRAPH PACKAGE (FHEC-11)  
 DAM SAFETY VERSION JULY 1978  
 LAST MODIFICATION 26 FEB 79  
 \*\*\*\*\*

RUN DATE= 79/11/21.  
 TIME= 12.36.34.

MISSOURI DAM SAFETY INSPECTIONS  
 OKAYOY RESERVOIR DAM  
 RATIOS OF PMF

NO MHR NMIN IDAY JOPER MWT LROPT TRACE  
 200 0 10 0 5 0 0 0 0

MULTI-PLAN ANALYSES TO BE PERFORMED  
 NPLAN= 1 NRATIO= 5 LRATIO= 1  
 RTIOS= .10 .20 .35 .50 1.00

\*\*\*\*\* SUB-AREA RUNOFF COMPUTATION \*\*\*\*\*

CALCULATION OF INFLOW HYDROGRAPHS

ISTAQ ICOMP TECOM ITAPE JPLY JPRY INAME ISTAGE IAUO  
 000001 0 0 0 2 0 1 0 0

HYDROGRAPH DATA

IHYDG	IUNG	TAREA	SNAP	TRSDA	TRSPC	RATIO	ISMOW	ISAME	LOCAL
1	2	2.19	0.00	2.19	1.00	0.000	0	1	0

PRECIP DATA

SPFE	PMS	R6	R12	R24	R48	R72	R96
0.00	24.70	102.00	121.00	130.00	140.00	0.00	0.00

LOSS DATA

LROPT	STRKR	DLTKR	RTIOL	ERATN	STRSK	RTIOK	STRTL	CRSTL	ALSMX	RTIAP
0	0.00	0.00	1.00	0.00	0.00	1.00	-1.00	-90.00	0.00	0.00

CURVE NO = -90.00 WEIENESS = -1.00 EFFECT CN = 90.00

UNIT HYDROGRAPH DATA

IC= 0.00 LAG= 1.03

RECESSION DATA

QRCSCN= .01 RTIOR= 1.00

UNIT HYDROGRAPH	33	END	CF	PERIOD	ORDINATES	IC	0.00	HOURS	LAG	1.03	VOL	1.00
61.	179.	368.	623.	828.	938.	944.	884.	781.	649.			
400.	373.	292.	233.	184.	141.	112.	88.	69.	53.			
42.	33.	26.	20.	16.	13.	10.	8.	7.	5.			







SLWF

STATION 000002

INFLUENCE, OUTFLOW (IN) AND OBSERVED FLOW (IN)

	0.	2000.	4000.	6000.	8000.	10000.	12000.	0.	0.	0.	0.	0.	0.
.10	11												
.20	21												
.30	31												
.40	41												
.50	51												
1.00	61												
1.10	71												
1.20	81												
1.30	91												
1.40	101												
1.50	111												
2.00	121												
2.10	131												
2.20	141												
2.30	151												
2.40	161												
2.50	171												
3.00	181												
3.10	191												
3.20	201												
3.30	211												
3.40	221												
3.50	231												
4.00	241												
4.10	251												
4.20	261												
4.30	271												
4.40	281												
4.50	291												
5.00	301												
5.10	311												
5.20	321												
5.30	331												
5.40	341												
5.50	351												
6.00	361												
6.10	371												
6.20	381												
6.30	391												
6.40	401												
6.50	411												
7.00	421												
7.10	431												
7.20	441												
7.30	451												
7.40	461												
7.50	471												
8.00	481												
8.10	491												
8.20	501												
8.30	511												
8.40	521												
8.50	531												
9.00	541												
9.10	551												
9.20	561												









PEAK FLOW AND STORAGE (END OF PERIOD) SUMMARY FOR MULTIPLE PLAN-RATIO ECONOMIC COMPUTATIONS  
 FLOWS IN CUBIC FEET PER SECOND (CUBIC METERS PER SECOND)  
 AREA IN SQUARE MILES (SQUARE KILOMETERS)

OPERATION	STATION	AREA	PLAN	RATIOS APPLIED TO FLOWS				
				RATIO 1	RATIO 2	RATIO 3	RATIO 4	RATIO 5
				.10	.20	.35	.50	1.00
HYDROGRAPH AT	000001	2.19 ( 5.67)	1 ( 29.81)	1053. 59.62	2106. 104.34	3685. 149.06	5264. 298.11	10528. 298.11
ROUTED TO	000002	2.19 ( 5.67)	1 ( 18.36)	1370. 38.81	3120. 88.34	4966. 140.63	10242. 290.02	

SUMMARY OF DAM SAFETY ANALYSIS

✓

PLAN 1 ..... INITIAL VALUE 615.00 SPILLWAY CREST 620.90 TOP OF DAM 620.90  
 ELEVATION STORAGE 53. 53. 333.  
 OUTFLOW 0. 0. 1605.

RATIO OF PMF	MAXIMUM RESERVOIR W.S.ELEV	MAXIMUM DEPTH OVER DAM	MAXIMUM STORAGE AC-FT	MAXIMUM OUTFLOW CFS	DURATION OVER TOP HOURS	TIME OF MAX OUTFLOW HOURS	TIME OF FAILURE HOURS
.10	618.46	0.00	194.	648.	0.00	41.67	0.00
.20	620.38	0.00	300.	1370.	0.00	41.67	0.00
.35	622.06	1.16	410.	3120.	3.00	41.17	0.00
.50	622.65	1.75	453.	4966.	4.33	40.83	0.00
1.00	623.88	2.58	547.	10242.	6.83	40.83	0.00