



AVRADCOM

Technical Report - 79-0270-5

ELECTRONIC MASTER MONITOR AND ADVISORY DISPLAY SYSTEM  
TEST AND DEMONSTRATION REPORT

GENERAL ELECTRIC COMPANY  
AIRCRAFT EQUIPMENT DIVISION  
BINGHAMTON, NY 13902

JUNE 1981

FIFTH INTERIM REPORT FOR PERIOD COVERING JAN 81 - JUN 81

DISTRIBUTION STATEMENT

Approved for public release;  
distribution unlimited.

PREPARED FOR:  
AVIONICS R&D ACTIVITY

AD A105317



Research and Development Technical Report  
Aviation Research and Development Command

HISA-FM-981-78

## NOTICES

### Disclaimers

The citation of trade names and names of manufacturers in this report is not to be construed as official Government indorsement or approval of commercial products or services referenced herein.

### Disposition

Destroy this report when it is no longer needed. Do not return it to the originator.

HISA-FM-633-78

UNCLASSIFIED

SECURITY CLASSIFICATION OF THIS PAGE (When Data Entered)

REPORT DOCUMENTATION PAGE		READ INSTRUCTIONS BEFORE COMPLETING FORM
1. REPORT NUMBER AVRADCOM-TR-79-0270-5	2. GOVT ACCESSION NO.	3. RECIPIENT'S CATALOG NUMBER
4. TITLE (and Subtitle) Electronic Master Monitor and Advisory Display Sys Test and Demonstration Report		5. TYPE OF REPORT & PERIOD COVERED R&D Jan 81-June 81
		6. PERFORMING ORG. REPORT NUMBER ACS - 12,388
7. AUTHOR(s)		8. CONTRACT OR GRANT NUMBER(s) DAAK80-79-C-0270
9. PERFORMING ORGANIZATION NAME AND ADDRESS General Electric Co. Aircraft Equipment Div		10. PROGRAM ELEMENT, PROJECT, TASK AREA & WORK UNIT NUMBERS 162-62202-AH-85-03-12-31
11. CONTROLLING OFFICE NAME AND ADDRESS Avionics R&D Activity Communications Sensors Instrumentation Division Fort Monmouth, N.J.		12. REPORT DATE June 81
		13. NUMBER OF PAGES 52
14. MONITORING AGENCY NAME & ADDRESS (if different from Controlling Office)		15. SECURITY CLASS. (of this report) UNCL
		15a. DECLASSIFICATION/DOWNGRADING SCHEDULE
16. DISTRIBUTION STATEMENT (of this Report)  Approved for public release, distribution unlimited		
17. DISTRIBUTION STATEMENT (of the abstract entered in Block 20, if different from Report)		
18. SUPPLEMENTARY NOTES		
19. KEY WORDS (Continue on reverse side if necessary and identify by block number) Subsystems, Test, Demonstration, Aircraft		
20. ABSTRACT (Continue on reverse side if necessary and identify by block number) This report documents the testing of the hardware and software provided for the feasibility Electronic Master Monitor and Advisory Display System (EMMADS)		

DD FORM 1473  
1 JAN 73

EDITION OF 1 NOV 65 IS OBSOLETE

UNCLASSIFIED

SECURITY CLASSIFICATION OF THIS PAGE (When Data Entered)

## PREFACE

This document establishes the requirements for contractual acceptance of the EMMADS Hardware supplied by General Electric under contract #DAAK 80-79-C-0270. The acceptance test proceedings will be held at the General Electric facility in Binghamton, New York. The individual tests are to be witnessed by a designated representative of the US Army Aviation Research and Development Command, Communications/Sensor Division, Instrumentation Branch, Fort Monmouth, New Jersey.







*off - Good & Keeney*

TABLE OF CONTENTS

	Sign Off	Date
1.0 Physical Characteristics	<i>[Signature]</i>	3-20
2.0 Workmanship	<i>[Signature]</i>	3-20
3.0 System Verification	N/A	N/A
3.1 Component/Package Functional Verification	N/A	N/A
3.1.1 MCP-701 Computer Diagnostic Functional Verification	<i>[Signature]</i>	3-20
3.1.2 TermiNet <sup>R</sup> 200 Functional Verification	<i>[Signature]</i>	3-20
3.1.3 Test Panel/Emulator Functional Verification	<i>[Signature]</i>	3-20
3.1.4 Bus Controller Functional Verification	<i>[Signature]</i>	3-20
3.1.5 Symbol Generator Functional Verification	<i>[Signature]</i>	3-20
3.1.6 Relegendable Switch Functional Verification	<i>[Signature]</i>	3-20
3.1.7 Key Pad Functional Verification	<i>[Signature]</i>	3-20
3.2 Integrated Operational Verification	N/A	N/A
3.2.1 Normal Operation Verification	N/A	N/A
3.2.1.1 Normal Operation: Acknowledge Switch Function	<i>[Signature]</i>	3-20
3.2.1.2 Normal Operation: Relegendable Switch Function	<i>[Signature]</i>	2-20
3.2.1.3 Normal Operation: Display Functions	N/A	N/A
3.2.1.3.1 Normal Operation: Display Functions-Analog Signal Range	<i>[Signature]</i>	3-20
3.2.1.3.2 Normal Operation: Display Functions-Analog Scale Range Delimiters	<i>[Signature]</i>	3-20
3.2.1.3.3 Normal Operation: Display Functions-Remaining Flight Time Clock	<i>[Signature]</i>	3-20

(Terminet<sup>R</sup> is a registered trademark of the General Electric Company)

TABLE OF CONTENTS (Continued)

	Sign Off	Date
3.2.2 Fault Detection Operation Verification	N/A	N/A
3.2.2.1 Fault Detection: Acknowledge Switch Function		3-20
3.2.2.2 Fault Detection: Relegendable Switch Function		3-20
3.2.2.3 Fault Detection: Display Functions	N/A	N/A
3.2.2.3.1 Fault Detection: Display Functions- Discrete Single Parameter Faults		3-20
3.2.2.3.2 Fault Detection: Display Functions- Analog Single Parameter Faults		3-20
3.2.2.3.3 Fault Detection: Display Functions- Multiple Parameter Faults (Engine 1&2 Failure)		3-20
3.2.2.3.4 Fault Detection: Display Functions- Fault Priority Handling		3-20
3.2.2.3.5 Fault Detection: Display Functions- Timed Parameter Limit Clock		3-20

## 1.0 INTRODUCTION

This Test and Demonstration Report is submitted in compliance with the EMMADS statement of work and contract data requirements. The purpose of the contract is to demonstrate the feasibility of an Electronic Master Monitor and Advisory Display System (EMMADS). The purpose of this report is therefore to document the testing of the hardware and software provided by the contractors when used in a system environment to demonstrate the feasibility of an EMMADS.

## 2.0 TYPE OF TESTING PERFORMED

By the statement of work and directive of Army personnel, the EMMADS program was to be a conceptual study of the EMMADS concept, and thus to design and fabricate a programmable feasibility model. However, the emphasis was to be placed on use of available hardware designs wherever possible to construct a system capable of demonstrating the concept. Testing was performed to an "Acceptance Test Procedure" developed with those objectives in mind.

Test 1.0 Physical Characteristics was intended simply to document the size and weight of all components.

Test 2.0 Workmanship was included to indicate Army acceptance of the general construction and workmanship of the various components. The equipment design and construction techniques are consistent with flight quality hardware. No environmental tests were required or conducted on any equipment under this contract.

The remainder of the tests were all related to System Verification. The first group of seven (7) tests are grouped under section 3.1 Component/Package Functional Verification and verify the functions of the various system modules. The last group of twelve (12) tests are grouped under section 3.2 Integrated Operational Verification and verify the various system operational modes.

### 3.0 TEST RESULTS

The complete Acceptance Test was performed at Ft. Monmouth on March 20, 1981. Tests were conducted by General Electric personnel and witnessed by the contract technical representative, who initialed each test procedure. No exceptions were taken on any test. Attached is a copy of the completed Acceptance Test Procedure with completion date and initials.

PAGE REVISION INDEX

Revision Dates - 0 (Original) - December 1980  
1 - January 1981  
2 - February 1981

<u>PAGE</u>	<u>REVISION</u>	<u>PAGE</u>	<u>REVISION</u>
i	0	25	2
ii	0	26	2
iii	0	27	2
1	0	28	2
2	0	29	2
3	0	30	2
4	0	30.1	2
5	2	31	2
6	2	32	2
7	2	33	2
7.1	2	34	2
7.2	2	35	2
8	2	36	2
9	1	37	2
10	1	38	2
11	0	39	2
12	2	40	2
13	2	41	2
14	2	42	2
15	1	43	2
16	2	44	2
16.1	2	45	1
17	2	46	2
18	2	47	2
19	2	48	2
20	2	49	2
21	2	50	0
22	1	51	2
23	1	52	1
24	2		

(NOTE: Revised material is indicated by a vertical hash mark on the right page margin. The absence of a hash mark indicates a new page or a complete page change.)

TEST NUMBER: 1.0

TITLE: Physical Characteristics

PURPOSE: Document the size and weight of all components.

INSTRUMENTATION:

1. Surface plate
2. Height gage
3. Scale

TEST PROCEDURE:

1. Place each item on surface plate and measure maximum dimensions with height gage.
2. Weigh each item on scale.

ACCEPTANCE CRITERIA: Dimensions and weight shall be recorded below.

<u>ITEM</u>	<u>WEIGHT (#)</u>	<u>DIMENSIONS (HWD)</u>
Test Panel	22.1	7.2 x 19.2 x 12.2 + Handle
MCP-701A (Emulator)	38.	7.6 x 10.3 x 19.6 + Handle
MCP-701A (EMMADS)	39.	7.6 x 10.3 x 19.6 + Handle
Display Panel	11.4	10.6 x 11.3 x 6.3
Keypad (TERMIFLEX™ Control/Display Unit)	1.3	7.0 x 4.2 x 2.1

TEST HISTORY:

DATE 3-20-81

STATUS OK

WITNESS P.H.

(TERMIFLEX™ is a trademark of the Termiflex Corporation)

TEST NUMBER: 2.0

TITLE: Workmanship

PURPOSE: Verify acceptable workmanship of all applicable EMMADS components.

TEST PROCEDURE: R&QA shall inspect all assemblies and subassemblies for proper workmanship and shall affix a stamp to each unit inspected which verifies the unit has met the appropriate inspection criteria.

ACCEPTANCE PROCEDURE: All assemblies and subassemblies shall be visually checked for the certification stamp affixed by R&QA.

TEST HISTORY:

DATE

3-22-8

STATUS

OK

WITNESS

[Signature]

TEST NUMBER: 3.1.1

TITLE: MCP-701A Computer Diagnostic Functional Verification

PURPOSE: Demonstrate that the MCP-701A computers do the basic computation and decisions required to operate the EMMADS system in a software programmable manner.

HARDWARE CONFIGURATION: All units with standard interconnections.

SOFTWARE REQUIRED: Operational programs for EMMADS and Emulator.

STIMULI: RS-232/C and symbol generator interrupts.

INSTRUMENTATION: None.

TEST PROCEDURE: No specific procedure required.

ACCEPTANCE CRITERIA: Observe that the computer responds as necessary to perform the tests of the remainder of Section 3.

TEST HISTORY:

DATE 3-20-81 STATUS OK WITNESS PIL

TEST NUMBER: 3.1.2

TITLE: TermiNet 200 MSR Printer Functional Verification

PURPOSE: Verify the operating capability of the TermiNet 200 MSR (Magnetic Send Receive) Printer.

HARDWARE CONFIGURATION: TermiNet 200 MSR Printer and EMMADS MCP-701A with standard interconnections.

SOFTWARE REQUIRED: Operational programs for EMMADS.

TEST PROCEDURE:

1. Power up system in normal configuration.
2. Use the TermiNet 200 MSR Printer to execute the operating system functions per the MCP-701A Operating System Manual (ACS 11,357) and cassette tape procedures.

ACCEPTANCE CRITERIA: The TermiNet 200 MSR Printer and EMMADS system shall respond per the documents referenced in the Test Procedure.

TEST HISTORY:

DATE 3-30-81 STATUS OK WITNESS PK

TEST NUMBER: 3.1.3

TITLE: Test Panel/Emulator Functional Verification

PURPOSE: Demonstrate the capability of the Emulator to cause analog and discrete inputs from the test panel to be transmitted on the 1553B data bus.

HARDWARE CONFIGURATION:

1. Data Bus Monitor/Controller (DBMC)
2. Remote Transmission Unit Emulator (RTU-EM)
3. System Test Panel

SOFTWARE REQUIRED:

1. Software to cause DBMC to act as a bus controller
2. RTU-EM Operational program

STIMULI: Various test panel pots and switches. (See Fig. 3.1.3)

TEST PROCEDURE:

1. Power up the RTU-EM, the DBMC and the system test set.
2. Observe the capability to vary the data displayed by the DBMC using test panel inputs and for each input change made, compare the location of the varying data on the display with that shown in Table 3.1.3(a)

ACCEPTANCE CRITERIA: Observe that data from the test panel can be placed on the bus and varied in accordance with locations defined in Table 3.1.3.

TEST HISTORY:

DATE 3-20-81 STATUS OK WITNESS RUF

DBMC DISPLAY - MAP OF TEST PANEL INPUTS

(ADIN = ANALOG/DIGITAL INPUT; DIN = DISCRETE INPUT)

(X - DON'T CARE)

BUS ID	CMND	DEST ADD	ADIN02	ADIN03	ADIN06	ADIN07	ADIN08	ADIN09	ADIN10	ADIN11	ADIN12	ADIN13	ADIN14
		ADIN15	ADIN16	ADIN17	ADIN18	ADIN19	ADIN20	ADIN21	ADIN22	ADIN26	ADIN27	ADIN29	ADIN28
		ADIN27	ADIN29	ADIN28	0000	ADIN01	ADIN04	ADIN05	0000	0000	0000	0000	ADIN30
BUS ID	CMND	DEST ADD	0000	0000	ADIN23	ADIN23	ADIN24	0000	0000	0000	0000	0000	ADIN30
		ADIN30	ADIN31	RWD1	RWD2	RWD3	RWD4						

DEFINITION OF DISCRETE WORDS SHOWN ABOVE

BIT VALUE

(DIN # INDICATES TEST PANEL DISCRETE INPUT CONTROLLING THAT BIT VALUE)

WORD	B0	B1	B2	B3	B4	B5	B6	B7	B8	B9	B10	B11	B12	B13	B14	B15
RWD1	DIN20	DIN21	DIN22	DIN23	DIN24	DIN25	DIN26	DIN27	DIN28	DIN29	DIN30	DIN31	0	0	0	0
RWD2	0	0	DIN14	DIN15	0	0	0	0	0	0	0	0	0	0	0	0
RWD3	X	X	X	X	X	X	X	X	X	X	X	X	X	X	X	X
RWD4	0	0	0	0	0	0	0	0	0	0	0	0	0	0	DIN32	0

TABLE 3.1.3(a)

(See Table 3.1.3(b) For Test Panel Parameter Locations)

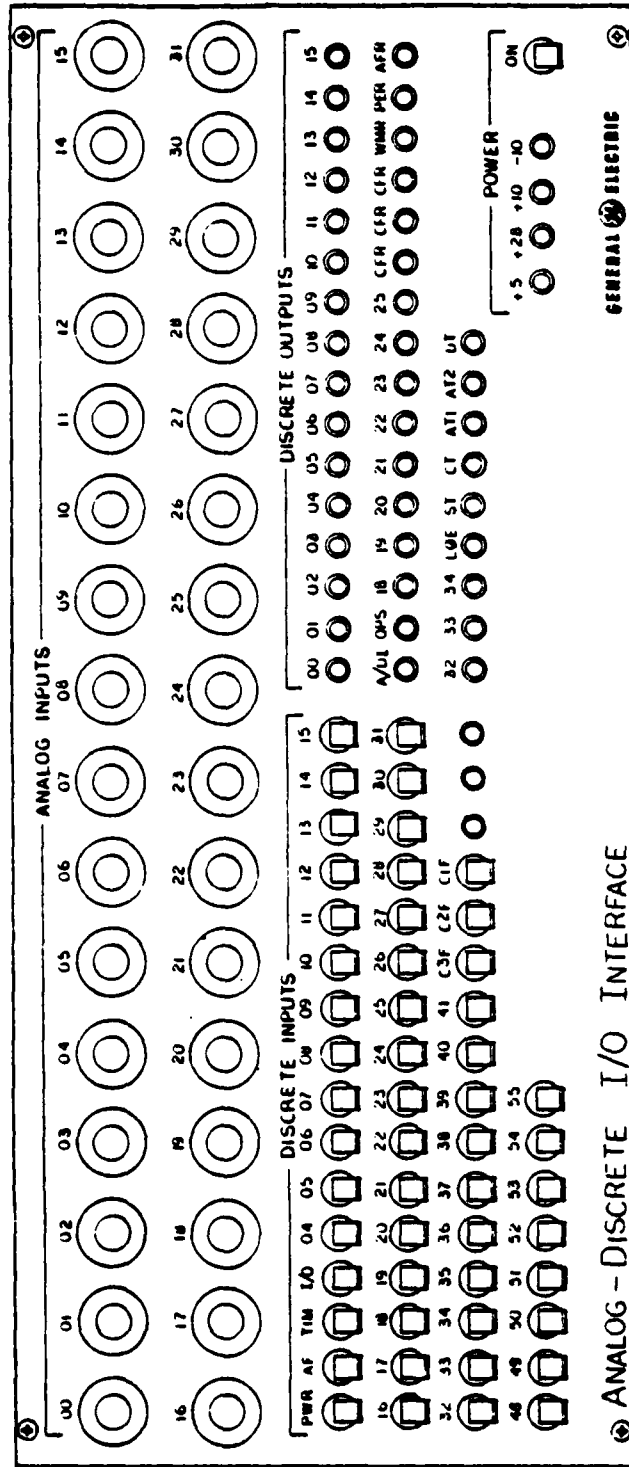

FIGURE 3.1.3

<u>TEST PANEL INPUT</u>	<u>CONTROLLED PARAMETER</u>
ADIN00	Eng 1 $N_1$
ADIN01	Eng 2 $N_1$
ADIN02	Eng 1 TGT
ADIN03	Eng 2 TGT
ADIN04	Eng 1 Torque
ADIN05	Eng 2 Torque
ADIN06	Eng 1 Oil Pressure
ADIN07	Eng 2 Oil Pressure
ADIN08	Eng 1 Oil Temperature
ADIN09	Eng 2 Oil Temperature
ADIN10	Eng 1 XMSN Oil Pressure
ADIN11	Eng 2 XMSN Oil Pressure
ADIN12	Combining XMSN Oil Pressure
ADIN13	Forward XMSN Oil Pressure
ADIN14	Aft XMSN Oil Pressure
ADIN15	Eng 1 XMSN Oil Temperature
ADIN16	Eng 2 XMSN Oil Temperature
ADIN17	Combining XMSN Oil Temperature
ADIN18	Forward XMSN Oil Temperature
ADIN19	Aft XMSN Oil Temperature
ADIN20	System 1 Flight Control Hydraulic Pressure
ADIN21	System 2 Flight Control Hydraulic Pressure
ADIN22	Utility Hydraulic Pressure
ADIN23	Cyclic Trim Actuator Position (Forward and Aft)
ADIN24	Rotor RPM
ADIN25	Spare
ADIN26	APU Accumulator Pressure
ADIN27	Fuel Quantity - Left & Right Forward Auxilliary Tanks
ADIN28	Fuel Quantity - Left & Right Aft Aux. Tanks
ADIN29	Fuel Quantity - Left & Right Main Tanks
ADIN30	Generator 1 & 2 Load
ADIN31	Rectifier 1 & 2 Load

TABLE 3.1.3(b)

<u>TEST PANEL INPUT</u>	<u>CONTROLLED PARAMETER</u>
DIN00-13	Spares
DIN14	Eng 1 Start Fuel
DIN15	Eng 2 Start Fuel
DIN16-19	Spares
DIN20	Eng 1 Oil Low
DIN21	Eng 2 Oil Low
DIN22	Eng 1 Chip
DIN23	Eng 2 Chip
DIN24	Eng 1 Condition Lever - Ground
DIN25	Eng 1 Condition Lever - Fly
DIN26	Eng 2 Condition Lever - Ground
DIN27	Eng 2 Condition Lever - Fly
DIN28	Eng 1 Ignition
DIN29	Eng 2 Ignition
DIN30	Eng 1 Starter
DIN31	Eng 2 Starter
DIN32	Acknowledge
DIN33	Faults Enable
DIN34	Ground Contact
DIN35-55	Spares

TABLE 3.1.3(b) con'td

TEST NUMBER: 3.1.4

TITLE: Bus Controller Functional Verification

PURPOSE: Demonstrate the capability of the EMMADS 701-A to act as a bus controller.

HARDWARE CONFIGURATION:

- 1) Data Bus/Monitor Controller (DBMC)
- 2) Remote Transmission Unit Emulator (RTU-EM)
- 3) EMMADS Raster Symbol Generator (ERSG)
- 4) System Test Panel
- 5) Terminet

SOFTWARE REQUIRED:

- 1) Software to cause DBMC to act as a bus monitor
- 2) Emulator operational program
- 3) EMMADS operational program

STIMULI: Various test panel pots and switches. (See Fig. 3.1.3)

TEST PROCEDURE:

- 1) Power up the ERSG, the RTU-EM, the DBMC and the system test panel
- 2) Observe bus traffic on the DBMC

ACCEPTANCE CRITERIA: Observe that the data transferred on the bus is similar to that displayed in test 3.1.3. Data can be placed on the bus from the test panel and varied in accordance with Table 3.1.3(a). Dump ERSG bus controller memory and note that it is the same as that displayed on the DBMC.

TEST HISTORY:

DATE 3-20-87 STATUS OK WITNESS [Signature]

TEST NUMBER: 3.1.5

TITLE: Symbol Generator Functional Verification

PURPOSE: Demonstrate the capability of the EMMADS raster symbol generator to display on a solid state display panel alphanumeric graphic and block filled symbols.

HARDWARE CONFIGURATION:

- 1) Remote Transmission Unit Emulator (RTU-EM)
- 2) EMMADS Raster Symbol Generator (ERSG)
- 3) Solid State Display Panel
- 4) System Test Panel
- 5) Relegendable Switches

SOFTWARE REQUIRED:

- 1) Emulator operational program
- 2) EMMADS operational program

STIMULI: Various test panel pots and switches. (See Fig. 3.1.3)

TEST PROCEDURE:

- 1) Power up the RTU-EM, the ERSG, the system test set and the solid state display.
- 2) Place fault enable switch (DIN-33) in "OFF" position.
- 3) Press display panel switch marked "ENG DATA".
- 4) Adjust Eng. 1 oil pressure pot (ADIN-06) until the display reads "110".
- 5) Place fault enable switch in "ON" position.

ACCEPTANCE CRITERIA: Observe that alphanumeric, graphic and block filled symbols are displayed on the solid state display panel.

TEST HISTORY:

DATE 3-20-51 STATUS OK WITNESS Rvk

TEST NUMBER: 3.1.6

TITLE: Relegendable Switch Functional Verification

PURPOSE: Demonstrate the capability to relegend the switches under the display.

HARDWARE CONFIGURATION:

- 1) Remote Transmission Unit Emulator (RTU-EM)
- 2) EMMADS Raster Symbol Generator (ERSG)
- 3) Solid State Display Panel
- 4) System Test Panel
- 5) Relegendable Switches

SOFTWARE REQUIRED:

- 1) Emulator operational program
- 2) EMMADS operational program

STIMULI: Relegendable switches under display panel.

TEST PROCEDURE:

- 1) Power up the RTU-EM, the ERSG, the system test set.
- 2) Press display panel switch marked "ENG DATA".

ACCEPTANCE CRITERIA: Observe that the switch legend changes to "ENG PROC" and that the switch marked "CHCK LSTS" becomes "STAT ONLY".

TEST HISTORY:

DATE 3-20-81 STATUS OK WITNESS RJA

TEST NUMBER: 3.1.7

TITLE: Key Pad Functional Verification

PURPOSE: Demonstrate that the Termiflex keypad and the EMMADS raster symbol generator can exchange information.

HARDWARE CONFIGURATION:

- 1) Remote Transmission Unit Emulator (RTU-EM)
- 2) EMMADS Raster Symbol Generator (ERSG)
- 3) System Test Panel
- 4) Termiflex keypad

SOFTWARE REQUIRED:

- 1) Emulator operational program
- 2) EMMADS operational program

STIMULI: Key entry from Termiflex

TEST PROCEDURES:

- 1) Power up the RTU-EM, the ERSG, the system test panel and the Termiflex keypad.
- 2) Place the Termiflex in the "ON LINE" mode.
- 3) Make a key entry on Termiflex.

ACCEPTANCE CRITERIA: Observe that the character entered from the Termiflex keypad appears on it's integral display.

TEST HISTORY:

DATE 3-20-81 STATUS OK WITNESS PCF

TEST NUMBER: 3.2.1.1

TITLE: Normal Operation: Acknowledge Switch Function

PURPOSE: Verify proper operation of the acknowledge switch when no faults are detected.

HARDWARE CONFIGURATION: All units with standard interconnections.

SOFTWARE REQUIRED: Operational programs for EMMADS and Emulator.

STIMULI: Applicable test panel switch. (See Fig. 3.1.3)

INSTRUMENTATION: None

TEST PROCEDURE:

1. Power up system in normal configuration
2. Place test panel discrete input (DIN) switch 32 in the ON position and note display reaction.
3. Place DIN 32 in the OFF position and note display reaction.

ACCEPTANCE CRITERIA: Switch movement should have no affect on the display.

TEST HISTORY:

DATE 3-20-81 STATUS OK WITNESS RUE

TEST NUMBER: 3.2.1.2

TITLE: Normal Operation: Relegendable Switch Function.

PURPOSE: Verify proper correlation between switch actuation, switch legend changes and display formats.

HARDWARE CONFIGURATION: All units with standard interconnections.

SOFTWARE REQUIRED: Operational programs for EMMADS and Emulator.

STIMULI: None.

INSTRUMENTATION: None.

TEST PROCEDURES:

1. Power up system in normal configuration.
2. Note display switch legends and display format and compare with Fig. 3.2.1.2(a).
3. Depress display panel switch labeled "ENG DATA" and note resulting switch legends and display format. Compare to Fig. 3.2.1.2(b).
4. Depress display panel switch labeled "ENG PROC" five times and note resulting switch legends and display formats. Compare with Figs. 3.2.1.2 (c), (d), (e), (f) and (a) in that order.
5. Depress display panel switch labeled "FUEL DATA" and note resulting switch legends and display format. Compare with Fig. 3.2.1.2(g). Depress display panel switch labeled "FUEL PROC" and compare resulting switch legends and display with Fig. 3.2.1.2(a).
6. Depress display panel switch labeled "XMSN DATA" and note resulting switch legends and display format. Compare with Fig. 3.2.1.2(h). Depress display panel switch labeled "XMSN PROC" and compare resulting switch legends and display with Fig. 3.2.1.2(a).
7. Depress display panel switch labeled "ELEC DATA" and note resulting switch legends and display format. Compare with Fig. 3.2.1.2(i). Depress display panel switch labeled "ELEC PROC" and compare resulting switch legends and display with Fig. 3.2.1.2(a).

TEST NUMBER: 3.2.1.2

TEST PROCEDURES:

8. Depress display panel switch labeled "HYDR DATA" and note resulting switch legends and display format. Compare with Fig. 3.2.1.2(j). Depress display panel switch labeled "HYDR PROC" and compare resulting switch legends and display with Fig. 3.2.1.2(a).
9. Depress display panel switch labeled "MISC DATA" and note resulting switch legends and display format. Compare with Fig. 3.2.1.2(k). Depress display panel switch labeled "MISC PROC" and compare resulting switch legends and display with Fig. 3.2.1.2(a).
10. Depress display panel switch labeled "CHCK LSTS" and note resulting switch legends and display format. Compare with Fig. 3.2.1.2(l).
11. Depress display panel switches labeled "EMER STRT", "NORM STRT", "T/O CHCK", "CRSE CHCK", "LNDG CHCK" and "SHUT DOWN" one at a time and in each case note the resulting condition of the display and the switch legends (there should be no change). Compare to those of Fig. 3.2.1.2(l).
12. Depress display panel switch labeled "PERF CALC" and note resulting switch legends and display format. Compare with Fig. 3.2.1.2(m).
13. Depress display panel switches labeled "HIT CHCK", "HVR PWR", "HVR WT", "MAX PWR", "WT & BAL" and "SYST TEST" one at a time and in each case note the resulting condition of the display and the switch legends (there should be no change). Compare to those of Fig. 3.2.1.2(m).
14. Depress display panel switch labeled "STAT ONLY" and note resulting switch legends and display format. Compare with Fig. 3.2.1.2(a).

TEST NUMBER: 3.2.1.2

ACCEPTANCE CRITERIA: The switch legends shall be in accordance with the figures referenced in the applicable Test Procedures item. The display format changes observed shall also be in accordance with said figures although the actual numeric values and scale indicator positions may vary from those in the figures.

TEST HISTORY:

DATE 3-20-81 STATUS OK WITNESS P.H.

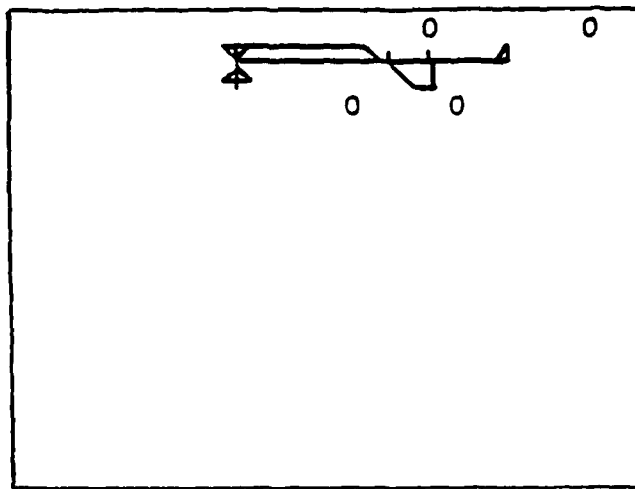

(a)

ENG DATA	FUEL DATA	XMSN DATA	ELEC DATA	HYDR DATA	MISC DATA	CHCK LSTS
----------	-----------	-----------	-----------	-----------	-----------	-----------

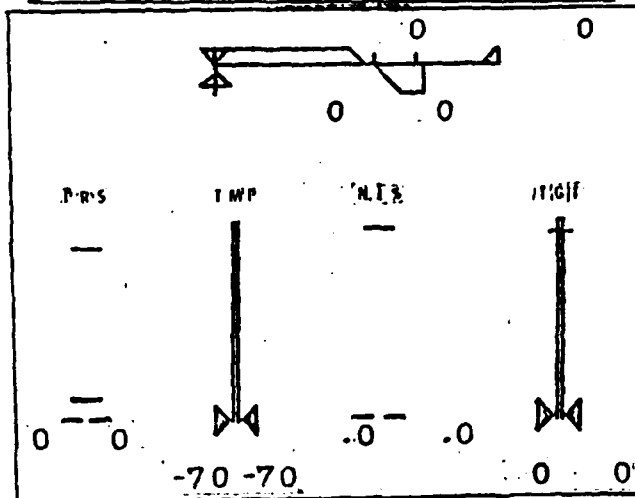

(b)

ENG PROC	FUEL DATA	XMSN DATA	ELEC DATA	HYDR DATA	MISC DATA	STAT ONLY
----------	-----------	-----------	-----------	-----------	-----------	-----------

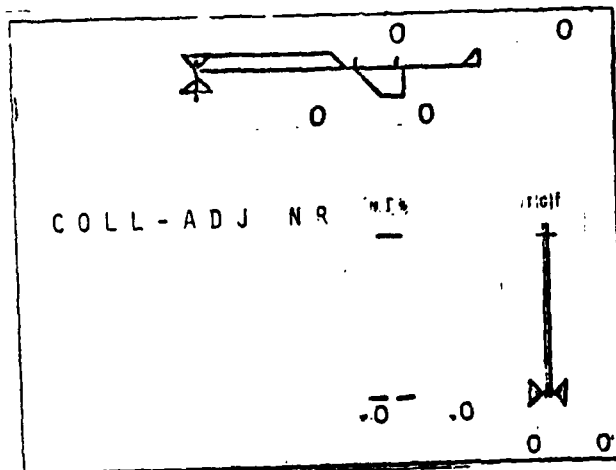

(c)

ENG PROC	FUEL DATA	XMSN DATA	ELEC DATA	HYDR DATA	MISC DATA	STAT ONLY
----------	-----------	-----------	-----------	-----------	-----------	-----------

Figure 3.2.1.2

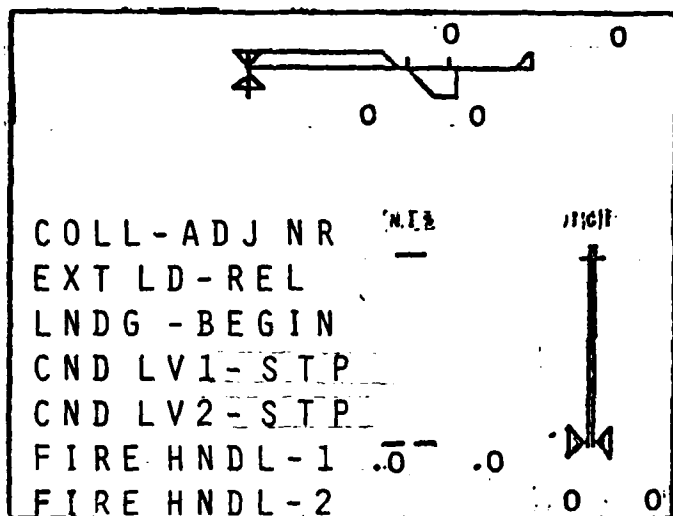

(d)

ENG PROC	FUEL DATA	XMSN DATA	ELEC DATA	HYDR DATA	MISC DATA	STAT ONLY
-------------	--------------	--------------	--------------	--------------	--------------	--------------

Figure 3.2.1.2 (cont)

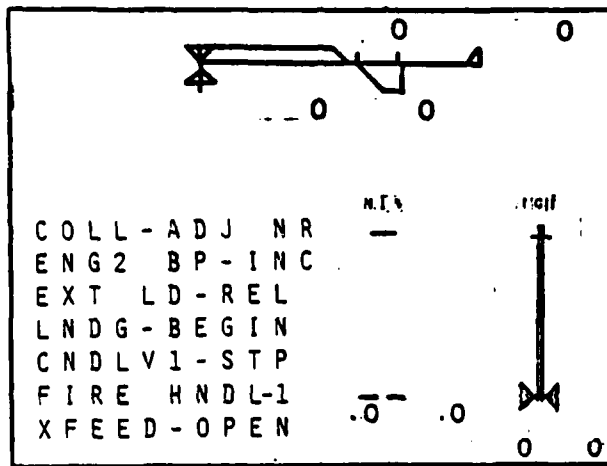

COLL - ADJ NR  
 ENG2 BP - INC  
 EXT LD - REL  
 LNDG - BEGIN  
 CNDLV1 - STP  
 FIRE HNDL-1  
 XFEED - OPEN

N.E.A. —

.0 .0

0 0

(e)

ENG PROC	FUEL DATA	XMSN DATA	ELEC DATA	HYDR DATA	MISC DATA	STAT ONLY
----------	-----------	-----------	-----------	-----------	-----------	-----------

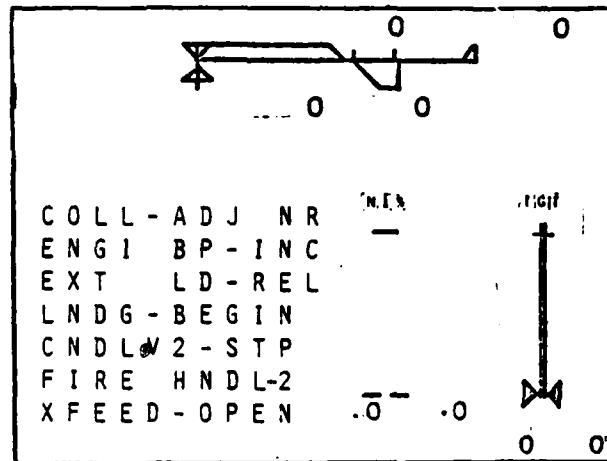

COLL - ADJ NR  
 ENGI BP - INC  
 EXT LD - REL  
 LNDG - BEGIN  
 CNDLV2 - STP  
 FIRE HNDL-2  
 XFEED - OPEN

N.E.A. —

.0 .0

0 0

(f)

ENG PROC	FUEL DATA	XMSN DATA	ELEC DATA	HYDR DATA	MISC DATA	STAT ONLY
----------	-----------	-----------	-----------	-----------	-----------	-----------

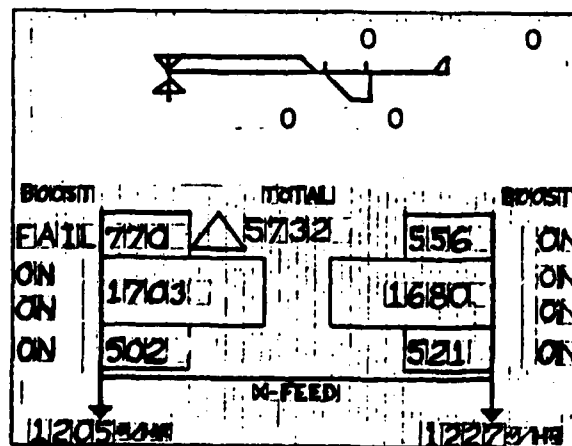

BOOSTI TOTALI BOOSTI

FAIL 7770 5732 556 ON

ON 1703 1680 ON

ON 502 521 ON

X-FEED

11205 11227

(g) Note: Actual digits in subsystem can vary.

ENG DATA	FUEL PROC	XMSN DATA	ELEC DATA	HYDR DATA	MISC DATA	STAT ONLY
----------	-----------	-----------	-----------	-----------	-----------	-----------

Figure 3.2.1.2 (con't.)

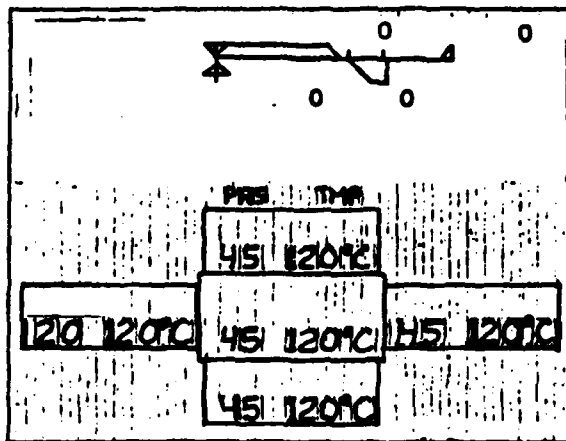

(h)

ENG DATA	FUEL DATA	XMSN PROC	ELEC DATA	HYDR DATA	MISC DATA	STAT ONLY
----------	-----------	-----------	-----------	-----------	-----------	-----------

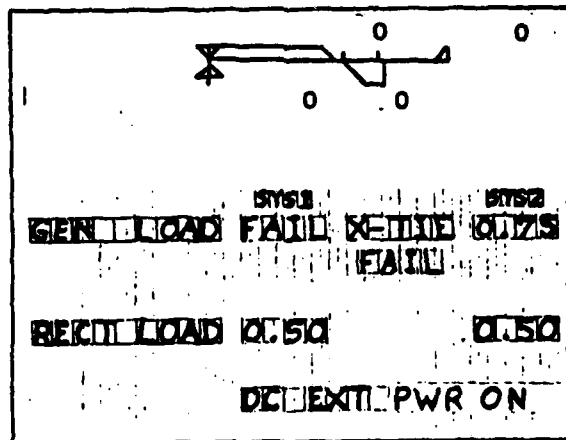

(i) Note: Actual digits in subsystems can vary.

ENG DATA	FUEL DATA	XMSN DATA	ELEC PROC	HYDR DATA	MISC DATA	STAT ONLY
----------	-----------	-----------	-----------	-----------	-----------	-----------

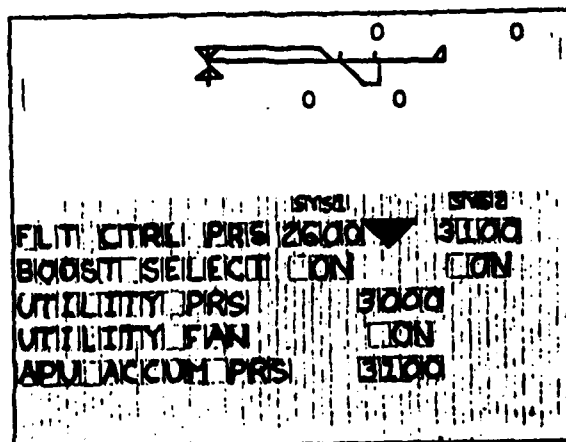

(j)

ENG DATA	FUEL DATA	XMSN DATA	ELEC DATA	HYDR PROC	MISC DATA	STAT ONLY
----------	-----------	-----------	-----------	-----------	-----------	-----------

Figure 3.2.1.2 (con't.)

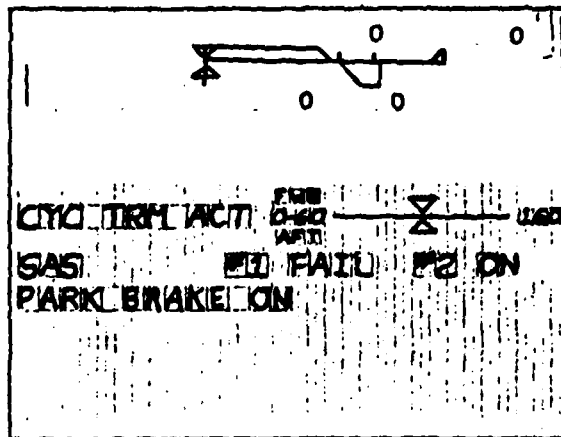

(k) Note: CYC TRM ACT symbol positions may be different.

ENG DATA	FUEL DATA	XMSN DATA	ELEC DATA	HYDR DATA	MISC PROC	STAT ONLY
----------	-----------	-----------	-----------	-----------	-----------	-----------

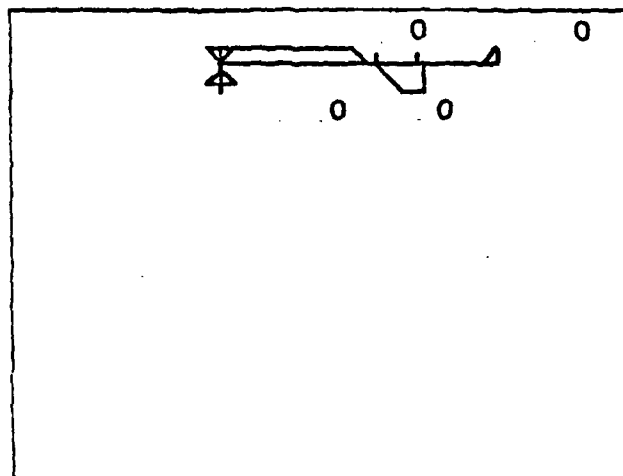

(l)

EMER STRT	NGRM STRT	T/O CHCK	CR SE CHCK	LNDG CHCK	SHUT DOWN	PERF CALC
-----------	-----------	----------	------------	-----------	-----------	-----------

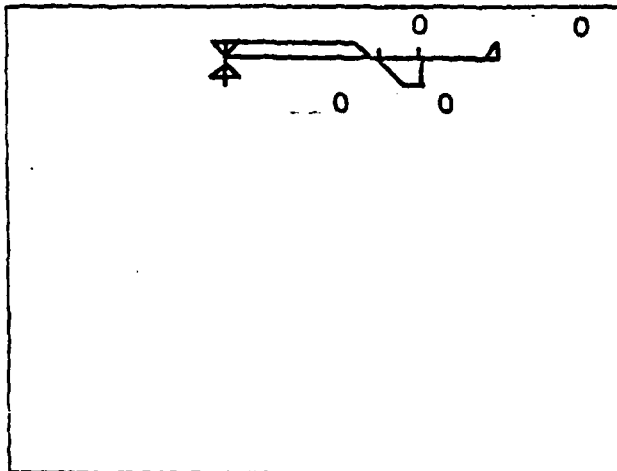

(m)

HIT CHCK	HVR PWR	HVR WT	MAX PWR	WT & BAL	SYST TEST	STAT ONLY
----------	---------	--------	---------	----------	-----------	-----------

Figure 3.2.1.2 (con't)

TEST NUMBER: 3.2.1.3.1

TITLE: Normal Operation: Display Functions - Analog Signal Range

PURPOSE: Verify the capability to drive all displayed analog indicators through their full dynamic range using related test panel analog inputs.

HARDWARE CONFIGURATION: All units with standard interconnections.

SOFTWARE REQUIRED: Operational programs for EMMADS and Emulator.

STIMULI: Inputs from system test panel. (See Fig. 3.1.3)

INSTRUMENTATION: None.

TEST PROCEDURE:

1. Power up system in normal configuration.
2. Depress panel switch marked "ENG DATA".
3. For each analog scale being checked verify full dynamic range available by turning the related test panel potentiometer and reading the signal value from the digital readout associated with the scale. Observe indicator movement over entire length of scale.

ACCEPTANCE CRITERIA: Display performance of tested signals shall meet the criteria set forth in Table 3.2.1.3.1.

TEST HISTORY:

DATE 3-20-81 STATUS OK WITNESS PK

Signal Name	Test Panel Input	Display Label	Minimum Range	Digital Value with Indicator at: Scale Minimum	Digital Value with Indicator at: Scale Maximum	Linear Scale Segments
Rotor Speed	24	none	0-290	0	$\geq 265(+1)$	0-207 207-265
Eng 1 Torque	04	none	0-150	0	$\geq 138(+1)$	0-140
Eng 2 Torque	05	none	0-150	0	$\geq 138(+1)$	
Eng 1 Oil Press	06	PRS	0-200	0	$\geq 190(+2)$	0-30 30-90 90-190
Eng 2 Oil Press	07		0-200	0	$\geq 190(+2)$	
Eng 1 Oil Temp	08	TMP	-70-150	$\leq -50$	$\geq 150(+1)$	-50 -150
Eng 2 Oil Temp	09		-70-150	$\leq -50$	$\geq 150(+1)$	
Eng 1 Gas Prod	00	N1%	0-110	0	$\geq 110(+.5)$	0-20 20-110
Eng 2 Gas Prod	01		0-110	0	$\geq 110(+.5)$	
Eng 1 Turbine Gas Temperature	02	TGT	0-999	0	999(+5)	0-400 400-600 600-900 900-999
Eng 2 Turbine Gas Temperature	03		0-999	0	999(+5)	

Table 3.2.1.3.1

TEST NUMBER: 3.2.1.3.2

TITLE: Normal Operation: Display Functions - Analog Scale Range  
Delimiters

PURPOSE: Verify proper position and turn-on/turn-off thresholds  
of scale delimiters.

HARDWARE CONFIGURATION: All units with standard interconnections.

SOFTWARE REQUIRED: Operational Programs for EMMADS and Emulator

STIMULI: Inputs from system test panel. (See Fig. 3.1.3)

INSTRUMENTATION: None

TEST PROCEDURE:

1. Power up system in normal configuration.
2. Depress display panel switch marked "ENG DATA".
3. Delimiter positions and turn-on/turn-off thresholds are tested using the Test Procedure Data portion of Table 3.2.1.3.2 in the following manner:
  - a. Under the Test Parameter column, locate the display scale name (on which the delimiter resides) and the test panel scale indicator control.
  - b. For each delimiter being tested, set all test panel A/D inputs (ADIN's) to zero (using the display readouts) and all discrete inputs (DIN's) low (OFF). Then establish any special starting conditions as shown by the table.
  - c. Beginning from the initial conditions, increase the Control Parameter to its maximum, observing the values of the Control Parameter when the delimiter turns on and off. Repeat this while decreasing the Control Parameter to its initial condition. The delimiter position is obtained by adjusting the Test Parameter scale indicator to coincide with the delimiter symbol and reading the scale's digital value.

TEST NUMBER: 3.2.1.3.2

TEST PROCEDURE: (Con't.)

3. d. For the first four parameters, conditions and parameter information is shown for the delimiter on the scale for either engine. For the NR (Rotor) and Torque scales, use of the word "OR" in the Special Conditions and Control Parameter columns indicates the tests should be run with each condition/parameter group separately. Use of the word "AND" indicates joint conditions/parameter adjustment should also be tested.
- e. Note that there is a special torque delimiter test which is based on a fixed torque value (ENG 1 or 2) and controlled by varying Rotor RPM (NR) from 230 to 245.

ACCEPTANCE CRITERIA: Delimiter positions and turn-on/turn-off thresholds shall agree with those shown in the Acceptance Criteria Data section of Table 3.2.1.3.2.

TEST HISTORY:

DATE

3-20-87

STATUS

OK

WITNESS

P. V. K.

TEST PROCEDURE DATA				ACCEPTANCE CRITERIA DATA						
TEST PARAMETER NAME	TEST PANEL INPUT	SPECIAL CONDITIONS	CONTROL PARAMETER NAME	TEST PANEL INPUT	DELIMITER SYMBOL	DELIMITER POSITION	THRESHOLDS			
							INCREASING TURN ON	DECREASING TURN OFF		
Oil Pressure (ENG1)	ADIN06	None	ENG1 N1	ADIN00	—	20±2	0	70±.5	70±.5	N/A
	ADIN07		ENG1 N2	ADIN01	—	35±1	70±.5	95±.5	70±.5	70±.5
Oil Temp (ENG1)	ADIN08	None	None	N/A	—	50±1	70±.5	N/A	N/A	75±.5
	ADIN09				—	90±1	95±.5	N/A	N/A	95±.5
Gas Producer (ENG1)	ADIN00	None	None	N/A	—	110±2	Contin	N/A	Contin	N/A
					—	138±2	Contin	N/A	Contin	N/A
	ADIN01	None	None	None	—	45±1	1,1,1	1,1,1	N/A	1,1,1
					—	60±1	1,0	1,0	N/A	1,0
Turbine Gas Temperature (ENG1)	ADIN02	None	None	None	—	65±1	0,1 or 1,1	N/A	N/A	0,0 or 1,0
					—	103±1	Contin	N/A	Contin	N/A
Turbine Gas Temperature (ENG2)	ADIN03	None	None	None	—	400±20	0	770±5	765±5	N/A
					—	770±5	0	810±5	805±5	N/A
	ADIN03	None	None	None	—	810±5	770±5	860±5	855±5	765±5
					—	860±5	810±5	N/A	N/A	805±5

Table 3.2.1.3.2 (Sheet 1 of 2)

TEST PROCEDURE DATA		ACCEPTANCE CRITERIA DATA							
TEST PARAMETER NAME	TEST PANEL INPUT	SPECIAL CONDITIONS	CONTROL PARAMETER NAME	TEST PANEL INPUT	DELIMITER SYMBOL	DELIMITER POSITION	THRESHOLDS		
							INCREASING TURN ON	DECREASING TURN OFF	
NR (ROTOR RPM)	ADIN24	None	NR	ADIN24		0+5	N/A	Cont'n	N/A
						232+1	N/A	Cont'n	N/A
						235+1	N/A	Cont'n	N/A
						245+1	N/A	Cont'n	N/A
						261+1	N/A	Cont'n	N/A
						265+1	N/A	Cont'n	N/A
						250+1	N/A	Cont'n	N/A
						255+1	N/A	249+1	N/A
						262+1	N/A	Cont'n	N/A
						214+1	0	232+1	230+1
Torque (ENG1) (ENG2)	ADIN04 ADIN05	ADIN04&05=41 (Torque) ADIN24=245 (Rotor) ADIN00 or 01 = 75 (N1) ADIN24=235 (Rotor) ADIN00 or 01 = 75 (N1) ADIN24=230 (Rotor) ADIN00 or 01 = 75 (N1)	ENG1 and/or 2 Torque  ENG 1 or 2 Torque	ADIN04/05  ADIN04or05		78+1	N/A	Cont'n	N/A
						100+1	N/A	Cont'n	N/A
						85+1	85+1	Cont'n	84+1
						97+1 (to I00)	N/A	85+1	N/A
						138+1	N/A	Cont'n	N/A
						89+1	89+1	Cont'n	88+1
						100+1	89+1	Cont'n	N/A
						138+1	N/A	Cont'n	N/A
						91+1	91+1	Cont'n	90+1
						100+1	91+1	Cont'n	90+1
138+1	Cont'n	Cont'n	N/A						
ADIN24=230 (NR) ADIN04 or 05=92 ADIN00 or 01 = 75 (N1)	ADIN24		NR	ADIN24			This is a special test on a delimiter just below the scale line. At 230-235 NR the delimiter is a short vertical line at 100+1 on the torque scale. As NR increases from 235 to 245 the line expands horizontally into a bar which runs from 91+1 to 100+1 when NR=245.		

TEST NUMBER: 3.2.1.3.3

TITLE: Normal Operation: Display Functions - Remaining Flight Time Clock

PURPOSE: Demonstrate the functional dynamic range of the Remaining Flight Time Clock.

HARDWARE CONFIGURATION: All units with standard interconnections.

SOFTWARE REQUIRED: Operational programs for EMMADS and Emulator.

STIMULI: Inputs from system test panel. (See Fig. 3.1.3)

TEST PROCEDURE:

1. Power up system in normal configuration.
2. Rotate test panel A/D inputs (ADIN) pots 27, 28 and 29 (fuel quantity in the forward, aft and main tanks) fully clockwise, simulating full fuel load. Note the indicated remaining flight time in minutes in the upper right hand display corner.
3. Slowly rotate each pot fully counter-clockwise and note behavior of clock.

ACCEPTANCE CRITERIA: When a full fuel load is simulated remaining flight time shall be  $195 \pm 1$  minute. The clock time shall decrease as fuel quantity decreases and remain stable to within  $\pm 1$  minute when pots are stationary. The clock time shall indicate zero when all pots are rotated fully counter clockwise.

TEST HISTORY:

DATE 3-20-87

STATUS OK

WITNESS PK

TEST NUMBER: 3.2.2.1

TITLE: Fault Detection:Acknowledge Switch Function

PURPOSE: Verify proper acknowledge switch function when faults are detected.

HARDWARE CONFIGURATION: All units with standard interconnections.

SOFTWARE REQUIRED: Operational programs for EMMADS and Emulator.

STIMULI: Inputs from system test panel. (See Fig. 3.1.3)

INSTRUMENTATION: None

TEST PROCEDURE:

1. Power up system in normal configuration, note display condition and compare with Fig. 3.2.2.1 (a).
2. Place discrete test panel input (DIN) switch 33 (Fault Enable) in the up (ON) position, note display conditions and compare with Fig. 3.2.2.1 (b).
3. Place DIN 32 in the ON position and then return to OFF, noting display in both cases. Compare with Fig. 3.2.2.1 (c).
4. Repeat Step 3 and compare display with Fig. 3.2.2.1 (d).

ACCEPTANCE CRITERIA: The display formats shall match those in Fig. 3.2.2.1 as referenced in each step of the test procedure.

TEST HISTORY:

DATE 3-20-87

STATUS OK

WITNESS PUK

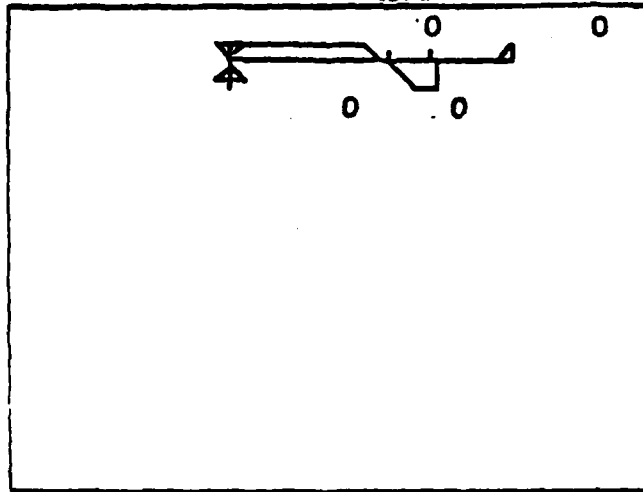

(a)

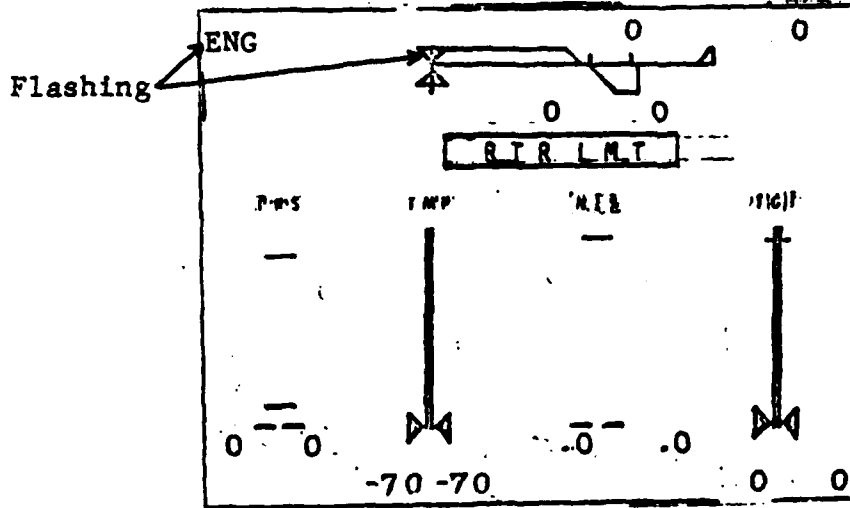

(b)

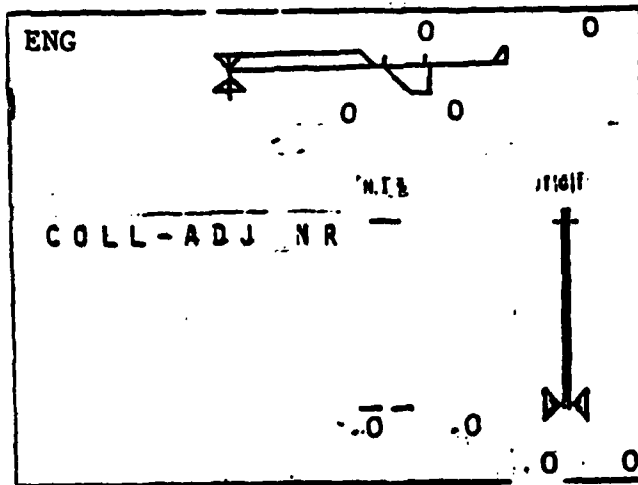

(c)

Figure 3.2.2.1

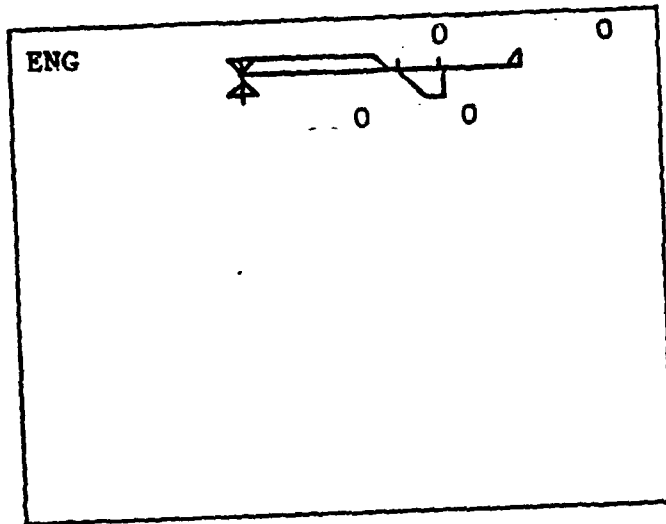

(d)

Figure 3.2.2.1 (cont)

28.1

TEST NUMBER: 3.2.2.2

TITLE: Fault Detection: Relegendable Switch Function

PURPOSE: Verify proper operation of relegendable switches when faults are detected.

HARDWARE CONFIGURATION: All units with standard interconnections.

SOFTWARE REQUIRED: Operational programs for EMMADS and Emulator.

STIMULI: Inputs from system test panel (See Fig. 3.1.3)

INSTRUMENTATION: None

TEST PROCEDURE:

1. Power up system in normal configuration, note display condition and switch legends and compare with Fig. 3.2.2.2(a).
2. Place discrete test panel input (DIN) switch 33 (Fault Enable) ON and compare display and switch legends with Fig. 3.2.2.2(b). Depress display panel switches labeled "FUEL DATA" "XMSN DATA", "ELEC DATA", "HYDR DATA", and "MISC DATA" in succession. Compare display condition and switch legends with Fig. 3.2.2.2(b).
3. Depress display panel switch labeled "ENG ACK" twice and compare display and switch legends with Figs. 3.2.2.2 (c) & (d) respectively.
4. Place DIN 33 OFF. Now compare display and switch legends to Fig. 3.2.2.2(a). Place DIN 25 ON and then DIN 33 also. Compare switch legends and display to Fig. 3.2.2.2(e).
5. Depress display panel switch labeled "WARN ACK" and compare display and switch legends with Fig. 3.2.2.2(d).
6. Depress display panel switch labeled "ENG DATA" and then "ENG PROC". Compare display and switch legends with Fig. 3.2.2.2(f). Depress the "ENG ACK" switch twice and compare the display and switch legends to Figs. 3.2.2.2(g) & (d) respectively.

ACCEPTANCE CRITERIA: The display formats and switch legends shall match those in Fig. 3.2.2.2 as referenced in each step of the test procedure.

TEST HISTORY:

DATE 3-20-57 STATUS OK WITNESS P. K.

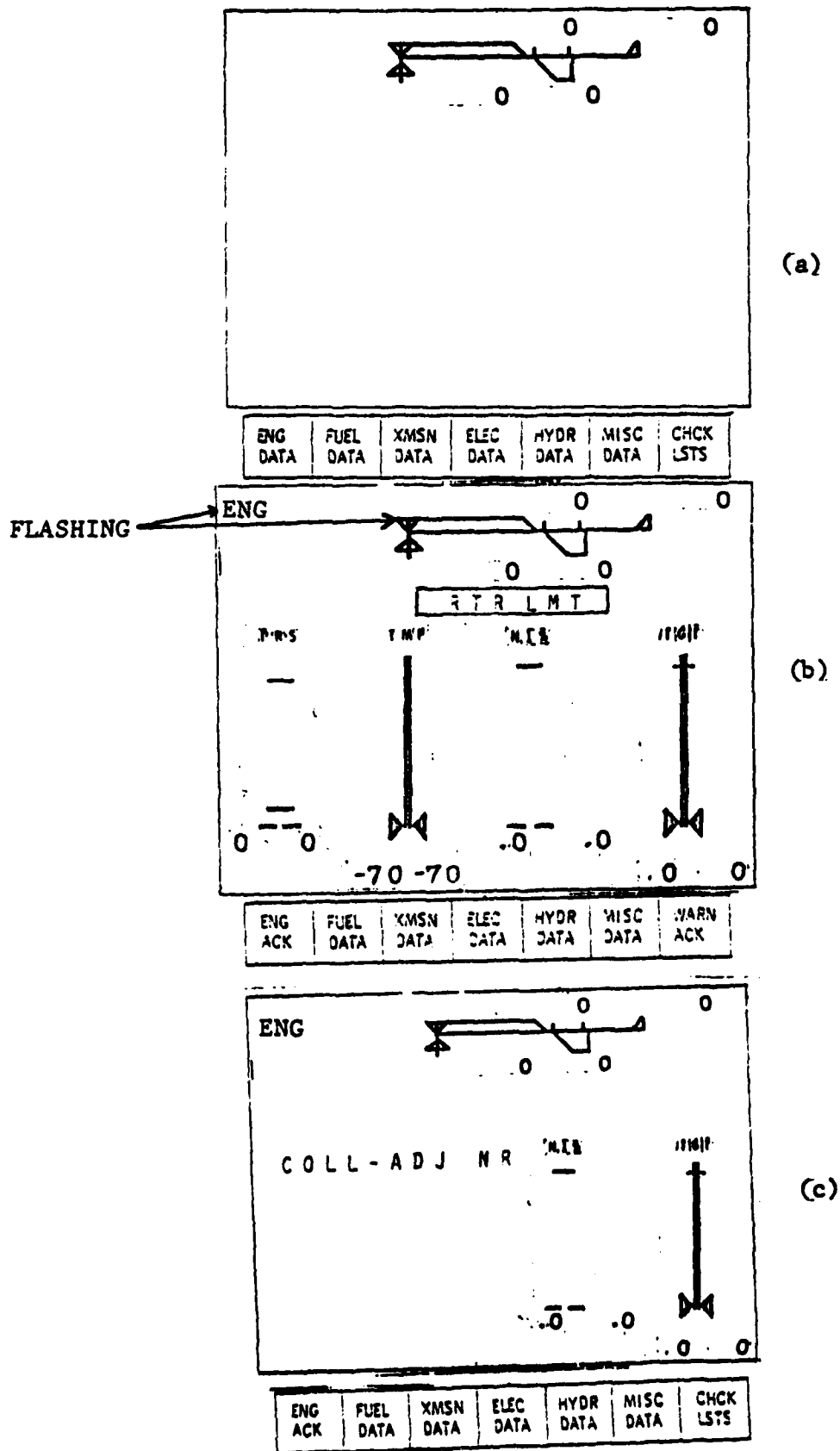
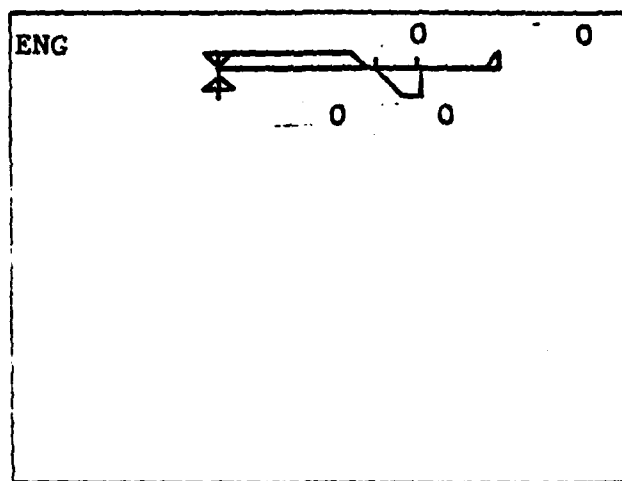

Figure 3.2.2.2



(d)

ENG DATA	FUEL DATA	XMSN DATA	ELEC DATA	HYDR DATA	MISC DATA	CHCK LSTS
-------------	--------------	--------------	--------------	--------------	--------------	--------------

Figure 3.2.2.2 (cont)

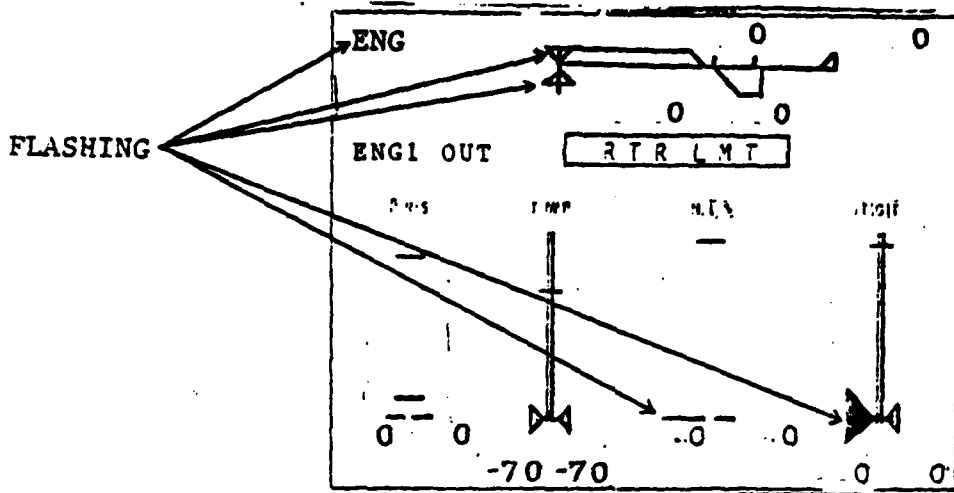

(e)

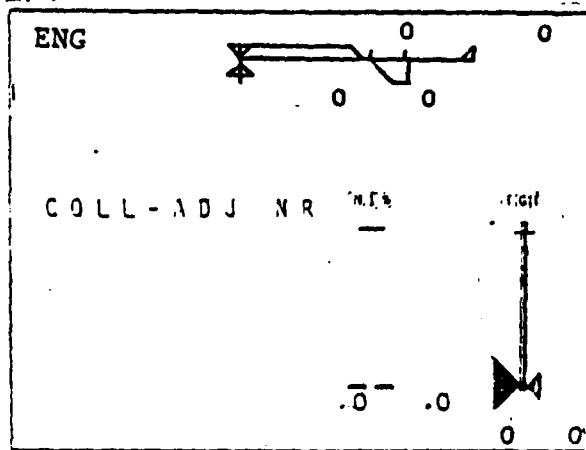

(f)

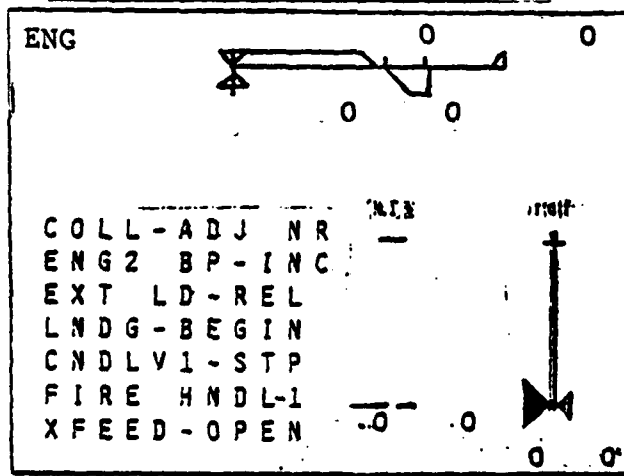

(g)

Figure 3.2.2.2 (con't)

TEST NUMBER: 3.2.2.3.1

TITLE: Fault Detection: Display Functions - Discrete Single  
Parameter Faults

PURPOSE: Verify proper display function when discrete single  
parameter faults are input to the system.

HARDWARE CONFIGURATION: All units with standard interconnections.

SOFTWARE REQUIRED: Operational Programs for EMMADS and Emulator

STIMULI: Test panel discrete inputs (See Fig. 3.1.3)

INSTRUMENTATION: None

TEST PROCEDURE:

1. Power up system in normal configuration and note the "No Fault" display condition. Compare with Fig. 3.2.2.3.1 (a).
2. Place DIN 33 (Fault Enable) in the ON position. Depress display panel switch labeled "WARN ACK".
3. Verification of the six discrete inputs (single parameter faults) is accomplished by reference to Table 3.2.2.3.1 as follows:
  - a. Setup initial conditions
  - b. Set the discrete fault input as shown.
  - c. Compare display condition with the indicated figure.
4. At the completion of each test, use the acknowledge switch (DIN 32) to reset the display

ACCEPTANCE CRITERIA: The display shall reflect the condition shown in the figures referenced for each test in Table 3.2.2.3.1 and as referenced above for other conditions.

TEST HISTORY:

DATE 3-20-81 STATUS OK WITNESS RJK

Table 3.2.2.3.1

<u>Initial Conditions</u>	<u>Discrete Input</u>	<u>Figure 3.2.2.3.1</u>
None	DIN 22 = 1 (Eng 1 Chip)	(b)
None	DIN 23 = 1 (Eng 2 Chip)	(c)
None	DIN 20 = 1 (Eng 1 Oil Low)	(d)
None	DIN 21 = 1 (Eng 2 Oil Low)	(e)
ADIN 04 = 1% (Eng 1 Torque)	DIN 24 & 25 = 1,1 (Eng 1 Cond. Lever Out of Detent)	(f)
ADIN 05 = 1% (Eng 2 Torque)	DIN 26 & 27 = 1,1 (Eng 2 Cond. Lever Out of Detent)	(g)

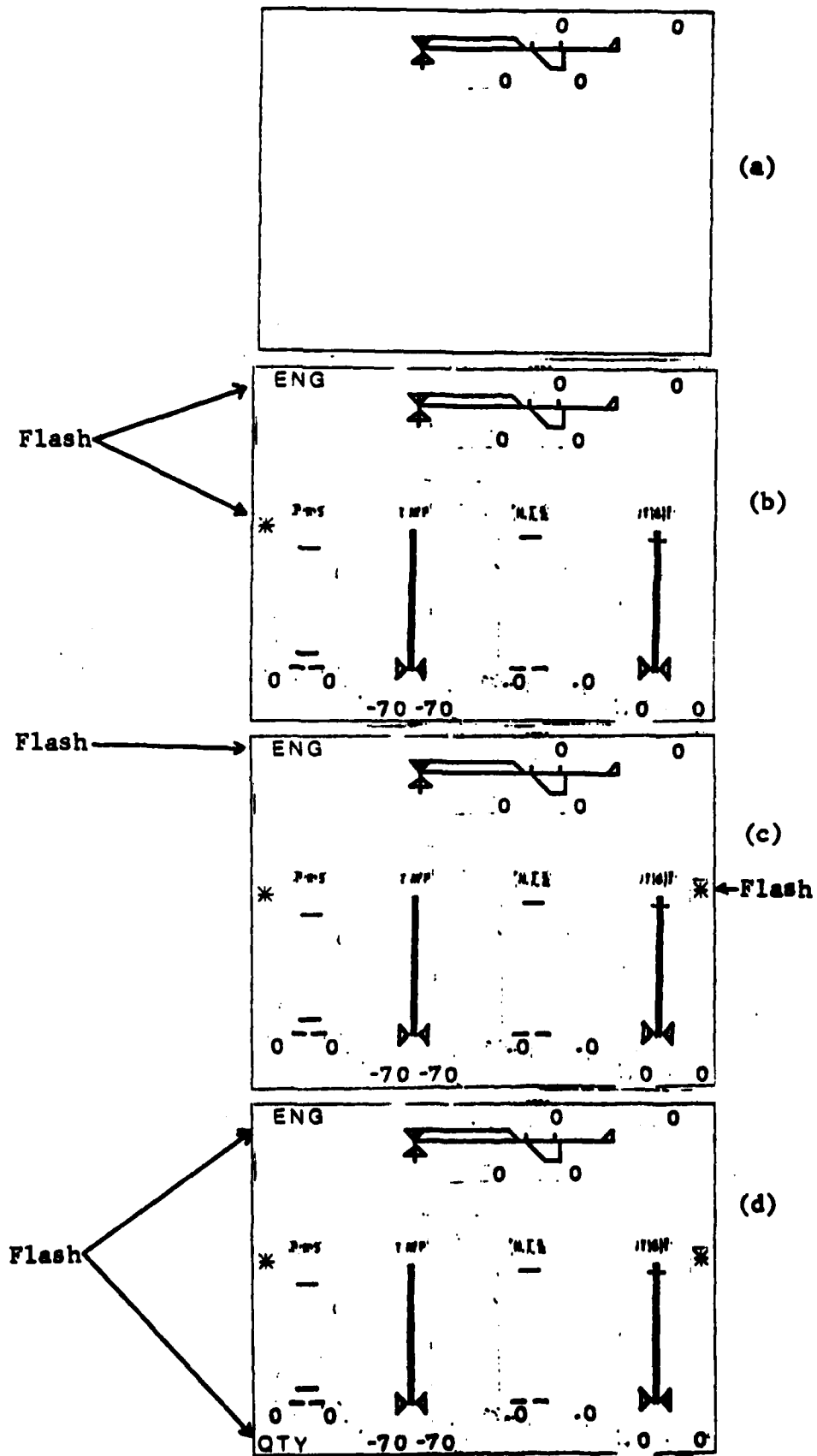

Figure 3.2.2.3.1

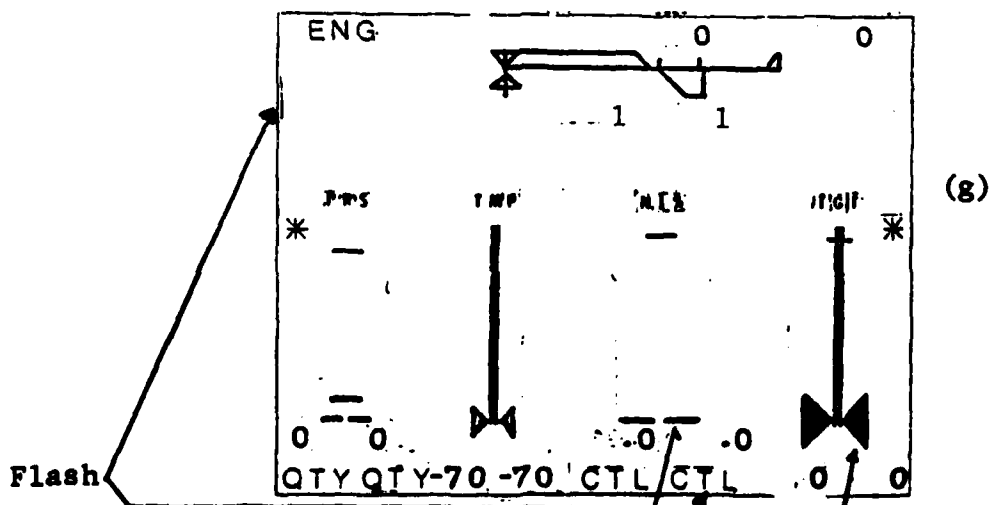
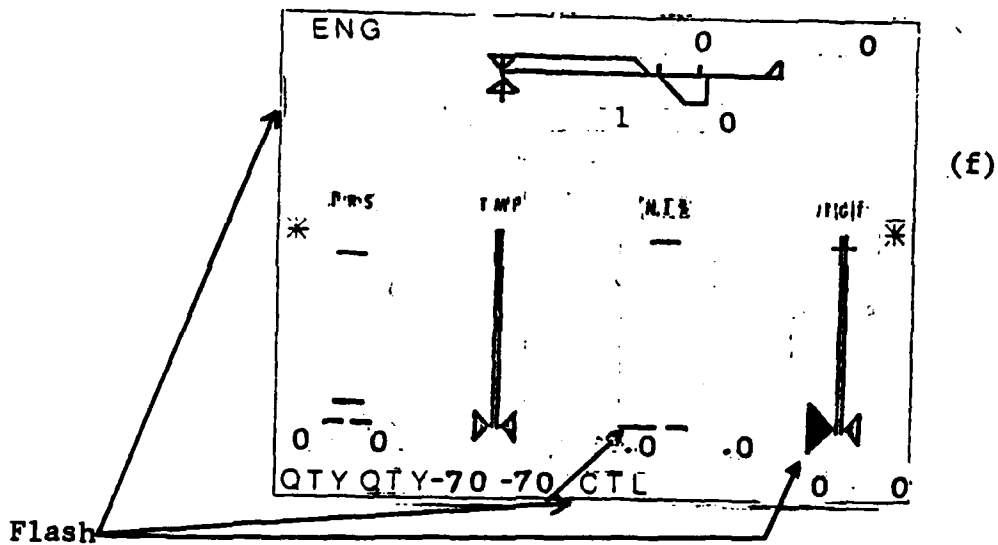
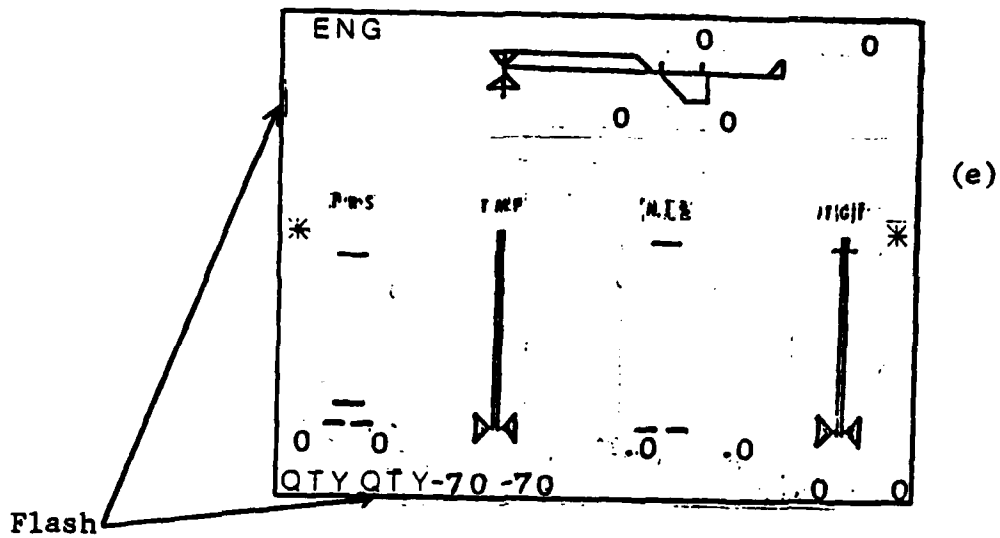

Figure 3.2.2.3.1 (con't)

TEST NUMBER: 3.2.2.3.2

TITLE: Fault Detection: Display Functions - Analog Single Parameter Faults.

PURPOSE: Verify proper display function when analog single parameter faults are input to the system.

HARDWARE CONFIGURATION: All units with standard interconnections.

SOFTWARE REQUIRED: Operational programs for EMMADS and Emulator.

STIMULI: Test panel analog and discrete inputs. (See Fig. 3.1.3)

INSTRUMENTATION: None

TEST PROCEDURE:

1. Power up system in normal configuration and compare the display condition with Fig. 3.2.2.3.1 (a).
2. Verification of analog single parameter fault algorithms proceeds as follows, using Table 3.2.2.3.2:
  - a. Prior to each test, display the engine subsystem using the "ENG DATA" display panel switch and set the analog portion of the Initial Conditions. (Include ADIN 24 = 240 rotor RPM for all except the rotor faults.)
  - b. Use the "STAT ONLY" display panel switch to remove the engine subsystem from the display.
  - c. Set the remaining discrete Initial Conditions and enable the faults by placing the discrete input (DIN) 33 in the ON position. Acknowledge any faults.
  - d. Slowly increase or decrease the Test Parameter from its initial condition, as indicated in the Table.
  - e. Note the value of the Test Parameter when the display indicates the fault condition has occurred.
  - f. When an initial condition is given as  $<$ ,  $>$ ,  $\leq$  or  $\geq$  with respect to certain limits, verify the fault exists within the indicated range(s) by varying the parameter(s) over all such values.
3. At the completion of each test, disable all faults by placing DIN 33 in the OFF position.

TEST NUMBER: 3.2.2.3.2 (con't.)

ACCEPTANCE CRITERIA: The test parameter value when a fault condition trips shall match that contained in the table. The analog scale indicator for the parameter under test shall appear oversized, filled in, and shall flash when the fault condition is first detected/displayed except for the torque and rotor symbols which will only flash. Also the word "ENG" shall appear in the upper left display corner and shall flash when the fault is detected, as shown in Fig. 3.2.2.3.1(b). In addition the rotor RPM faults shall display a message capsule as shown in Fig. 3.2.2.2(b).

TEST HISTORY:

DATE 3-20-81 STATUS OK WITNESS DJK

TEST PARAMETER NAME	TEST PANEL INPUT	INITIAL CONDITIONS	TEST PARAMETER			
			INCREASE	DECREASE	FAULT THRESHOLD	
Engine 1 Oil Pressure	ADIN06	ADIN 06=30 (ENGL Oil Press) ADIN 00<45 (ENGL N1)		X	None	
		ADIN 06=30 45<ADIN00<70		X	20±1	
		ADIN06=40 70<ADIN00<95		X	35±1	
			X		50±1	
		ADIN06=70 ADIN00>95		X	50±1	
			X		90±1	
		ADIN06=0	X		110±1	
Engine 2 Oil Pressure	ADIN07	(Same test as above, substituting ADIN01 (ENG 2 N1) for ADIN00, and ADIN07 for ADIN06)				
Engine 1 Oil Temperature	ADIN08	ADIN08=0	X		138±1	
Engine 2 Oil Temperature	ADIN09	ADIN09=0	X		138±1	
Engine 1 Gas Producer (N1)	ADIN00	ADIN04 > 5 (ENGL Torque) ADIN06 > 20 (ENGL Oil Press) ADIN00 = 62 DIN24 = 1 (ENGL Cond Lever - Ground)		X	60±.5	
		ADIN04 > 5, ADIN06 > 20 ADIN00=68, DIN25=1 (ENGL Cond Lever-Flight)		X	63±.5	
		DIN24,25=0,1 (ENGL Cond. Lever-FLIGHT) ADIN04>5, 50<ADIN06<90, ADIN00=98 (Note: The fault should not be disabled by changing the states of DIN 24+25)	X			103±.5
Engine 2 Gas Producer (N1)	ADIN01	(Same tests as above, substituting ADIN 05+07 for ADIN 04+06 respectively and DIN 26,27 (ENG2 Cond. Lever) for DIN 24,25				
ENGL Turbine Gas Temp	ADIN02	ADIN02=0 DIN14,28,30=1,1,1 (ENGL Start Fuel, Ignition and Starter)	X		788±1	
		ADIN02=0	X		260±1	
			X		350±1	
		ADIN02=450, ADIN00=75, 35 < ADIN06 < 50 DIN24,25=0,0 (ENGL Cond. Lever not in STOP)		X	399±1	
			X		770±1	
		ADIN02=780 (Rest same as above) DIN24,25=0,0	X		810±1	
		ADIN02=840 (Rest same as above) DIN24,25=0,0	X		860±1	
		ADIN02=870	X		927±1	
ENG2 Turbine Gas Temp	ADIN03	(Same test as above, substituting DIN 15,29,31,26 & 27 for DIN 14,28,30,24&25 respectively. Also ADIN 01+07 for ADIN 00+06 respectively.				
Engine 1 Torque	ADIN04	ADIN04=50	X		78±1	
		ADIN04=80 (Do not confuse with 10 second ADIN05=50 time out fault)	X		100±1	
		ADIN04=50 ADIN06=40 ADIN24>245 (Rotor RPM) ADIN00=75	X		85±1	
		ADIN04=85 ADIN06=40 ADIN24=240 ADIN00=75	X		87±1	
		ADIN04=87 ADIN06=40 ADIN24=235 ADIN00=75	X		89±1	
		ADIN04=89 ADIN06=40 ADIN24<230 ADIN00=75	X		91±1	
		ADIN04=87 ADIN06=40 ADIN24>245 ADIN00=75	X		97±1	
		ADIN04=96 ADIN06=40 ADIN24<235 ADIN00=75	X		100±1	
		ADIN04=98 ADIN06=40 ADIN24>245 ADIN00=75	X		100±1	
		ADIN04=110 ADIN06=90	X		138±1	

Table 3.2.2.3.2 (Sheet 1 of 2)

TEST PARAMETER NAME	TEST PANEL INPUT	INITIAL CONDITONS	TEST PARAMETER		
			INCREASE	DECREASE	FAULT THRESHOLD
Engine 2 Torque	ADIN05	(Same tests as above, substituting ADIN01,05+07 for ADIN00,04+06 respectively)			
Rotor RPM	ADIN24	ADIN24=245		X	232 $\pm$ .5
			X		261 $\pm$ .5
		ADIN24=263	X		265 $\pm$ .5
		ADIN04=50 (ENGL Torque) ADIN24=240		X	232 $\pm$ .5
			X		250 $\pm$ .5
		ADIN04=50 ADIN24=252	X		255 $\pm$ .5
		ADIN04=50 ADIN24=260	X		262.5 $\pm$ .5
		ADIN00=67 DIN25.34=1.1 (ENGL Cond.Lever-FLIGHT & ADIN 04=12 Ground Contact switch ON) ADIN24=240		X	214 $\pm$ .5

Table 3.2.2.3.2 (Sheet 2 of 2)

TEST NUMBER: 3.2.2.3.3

TITLE: Fault Detection: Display Functions-Multiple Parameter Faults  
(Engine 1&2 Failure)

PURPOSE: Verify proper display function when multiple parameter faults are input to the system.

HARDWARE CONFIGURATION: All units with standard interconnections.

SOFTWARE REQUIRED: Operational programs for EMMADS and Emulator.

STIMULI: Test panel analog and discrete inputs. (See Fig. 3.1.3)

INSTRUMENTATION: None.

TEST PROCEDURE:

1. Power up system in normal configuration and compare the display condition with Figure 3.2.2.3.1 (a).
2. Verification of engine failure detection algorithms proceeds as follows, using Table 3.2.2.3.3:
  - a. Prior to each test, display the engine subsystem using the "ENG DATA" display panel switch and set the analog initial conditions.
  - b. Use the "STAT ONLY" display panel switch to remove the engine subsystem from the display.
  - c. Set the remaining Initial Conditions and enable the faults by placing the discrete input (DIN) 33 in the ON position. Acknowledge any faults.
  - d. Slowly decrease the Control Parameter until the fault condition is displayed. Compare the threshold value to that in the table.
  - e. At the completion of each test, take the action indicated by the table. For tests 9, 18 & 19 cycle the acknowledge switch twice in order to first display then clear the appropriate checklist. After so doing, disable all faults as with the other tests.

TEST NUMBER: 3.2.2.3.3 (con't.)

ACCEPTANCE CRITERIA: The Engine 1 and Engine 2 Failure faults shall be activated at the appropriate threshold indicated by Table 3.2.2.3.3 for each test. In addition the following display characteristics shall be observed:

1. For tests 1-8 the boxed in warning message

ENG 1 OUT

shall be positioned in the top left corner of the Warning Message Area described by Figure 3.2.2.3.3(a). Also, the ENG 1 Torque, N1, and TGT scale indicators shall be flashing and the latter two will also be oversized and filled in.

2. For tests 10-17 observe a boxed in warning message

ENG 2 OUT

positioned in the upper right corner of the Warning Message Area. The ENG 2 Torque, N1 and TGT scale indicators shall behave as described above for tests 1-8.

3. For tests 9 & 18 observe that after enabling the faults, oil pressure and temperature, N1, TGT & CTL faults are displayed for the appropriate engine. When the Engine Out fault is detected however, the oil pressure and temperature scale indicators shall return to normal size, not flashing or filled in.
4. For test 9, acknowledging the fault shall remove the warning message, stop all symbols except CTL from flashing and replace the oil pressure and temperature scales with the checklist in Figure 3.2.2.3.3(b). The same is true for test 18 except the checklist is that of Figure 3.2.2.3.3(c).
5. For test 19, the symbology related to both engine failures shall appear simultaneously when the fault enable operation

TEST NUMBER: 3.2.2.3.3 (con't.)

is completed. The response to acknowledgement shall be as described in 4. above except the checklist is that shown in Fig. 3.2.2.3.3(d).

TEST HISTORY:

DATE 3-20-57 STATUS OK WITNESS JVK

Eng No.	Test No.	Initial Conditions					Control Parameter	Fault Threshold	At Fault Completion
		N1	TGT	Torque	Other				
1	1	ADIN00=75	ADIN02=350	ADIN04= 5	DIN 25=1(Condition Lever in FLIGHT) ADIN24=245 (Rotor RPM) ADIN06= 40 (Oil Press)	N1	<70+1	DIN 33=0 (Fault Disable)	
	2	ADIN00=65	ADIN02= 50	ADIN04= 5					
	3	ADIN00=65	ADIN02=350	ADIN04=15					
	4	ADIN00=70	ADIN02=300	ADIN04=0	DIN 24=1(Condition Lever in GROUND) ADIN24=245 (Rotor RPM) ADIN06= 40 (Oil Press)	TGT	<350+1		
	5	ADIN00=60	ADIN02=370	ADIN04=0					
	6	ADIN00=60	ADIN02=300	ADIN04= 5					
	7	ADIN00=65	ADIN02=350	ADIN04=0	DIN 24, 25=1,1 (Cond. Lever Out of Detent) ADIN24=245 (Rotor RPM)	Torque	<1		
	8	ADIN00=55	ADIN02=450	ADIN04=0					
	9	ADIN00=55	ADIN02=350	ADIN04= 5	ADIN06=130 (Oil Press) ADIN08=145 (Oil Temp) ADIN24=245 (Rotor RPM) DIN 24, 25=1,1	Torque	<1		DIN 32=1→0 (Acknowledge)
2	10-12	(Same as above substituting ADIN 01,03,05 & 07 for ADIN00,02,04&06 & DIN 26&27 for DIN24&25 respectively)					(Same as for Tests 1-3 respectively)		
	13-15	(Same as Tests 4-6 using substitutions listed above)					(Same as for Tests 4-6 respectively)		
1&2	16-18	(Same as Tests 7-9 using substitutions listed above, plus using ADIN07&09 instead of ADIN06&08 in Test18)					(Same as for Tests 7-9 respectively)		
	19	ADIN00=65 ADIN01=65	ADIN02=300 ADIN03=300	ADIN04= 5 ADIN05= 5	DIN 25, 27=1,1	N/A	N/A	DIN 32=1→0	

WARNING MESSAGE AREA

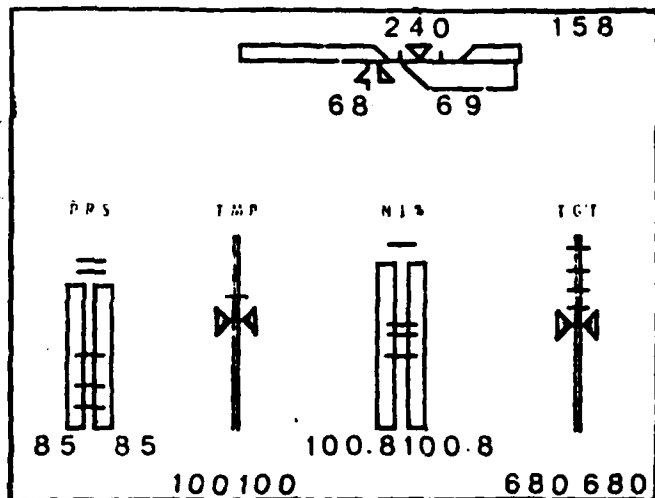

(a) General Display showing Warning Message Area

COLL - ADJ NR  
 ENG 2 BP - INC  
 EXT LD - REL  
 LNDG - BEGIN  
 CND LV 1 - STP  
 FIRE HNDL - 1  
 XFEED - OPEN

(b) Engine 1 Out Emergency Checklist

COLL - ADJ NR  
 ENG 1 BP - INC  
 EXT LD - REL  
 LNDG - BEGIN  
 CND LV 2 - STP  
 FIRE HNDL - 2  
 XFEED - OPEN

(c) Engine 2 Out Emergency Checklist

COLL - ADJ NR  
 EXT LD - REL  
 LNDG - BEGIN  
 CND LV 1 - STP  
 CND LV 2 - STP  
 FIRE HNDL - 1  
 FIRE HNDL - 2

(d) Dual Engine Out Emergency Checklist

Figure 3.2.2.3.3

TEST NUMBER: 3.2.2.3.4

TITLE: Fault Detection: Display Functions-Fault Priority Handling

PURPOSE: Verify proper handling by EMMADS of various priority faults.

HARDWARE CONFIGURATION: All units with standard interconnections.

SOFTWARE REQUIRED: Operational programs for EMMADS and Emulator.

STIMULI: Various test panel inputs. (See Fig. 3.1.3)

INSTRUMENTATION: None.

TEST PROCEDURE:

1. Power up system in normal configuration and compare display condition with Figure 3.2.2.3.1(a).
2. Select the engine subsystem for display using the "ENG DATA" display panel switch.
3. Set the following initial conditions:
  - a. ADIN 00=98 (Eng 1 N1)
  - b. ADIN 02=680 (Eng 1 TGT)
  - c. ADIN 04=75 (Eng 1 Torque)
  - d. ADIN 06=60 (Eng 1 Oil Pressure)
  - e. ADIN 08=100 (Eng 1 Oil Temperature)
  - f. ADIN 24=245 (Rotor RPM)
  - g. DIN 25,27=1,1 (Eng 1 & 2 Condition Levers in FLIGHT)
4. Clear the engine subsystem by depressing the "STAT ONLY" display panel switch. Enable all faults by placing DIN 33 ON and compare the display with Figure 3.2.2.3.4(a). Observe the Eng2 Torque, N1 and TGT scale indicators and the word "ENG" in the upper left display corner all flash.
5. Decrease rotor rpm (ADIN 24) to 230 and compare the display with Figure 3.2.2.3.4(b). Observe rotor rpm pointer now is also flashing.
6. Acknowledge the rotor rpm fault (DIN 32 ON then OFF) and

TEST NUMBER: 3.2.2.3.4 (con't.)

compare display with Figure 3.2.2.3.4(c). Observe rotor rpm pointer not flashing.

7. Acknowledge the rotor rpm checklist (DIN 32 ON then OFF) and compare display with Figure 3.2.2.3.4(d).
8. Acknowledge the ENG 2 Failure fault (DIN 32 ON then OFF) and compare display with Figure 3.2.2.3.4(e). Note all flashing ceases.
9. Set DIN 20 and DIN 21 to ON (ENG 1 & 2 Oil Quantity Low) and compare display to Fig. 3.2.2.3.4(e). Note that the only change is that the word "ENG" again begins to flash.
10. Acknowledge the engine failure checklist (DIN 32 ON then OFF) and compare display with Figure 3.2.2.3.4(f). Note that the words "ENG" and QTY" flash.
11. Acknowledge the "QTY" faults and compare display with Figure 3.2.2.3.4(g).

ACCEPTANCE CRITERIA: The display symbology shall correspond to the figures and other criteria cited in each Test Procedure step.

TEST HISTORY:

DATE 3-20-81 STATUS OK WITNESS PJK

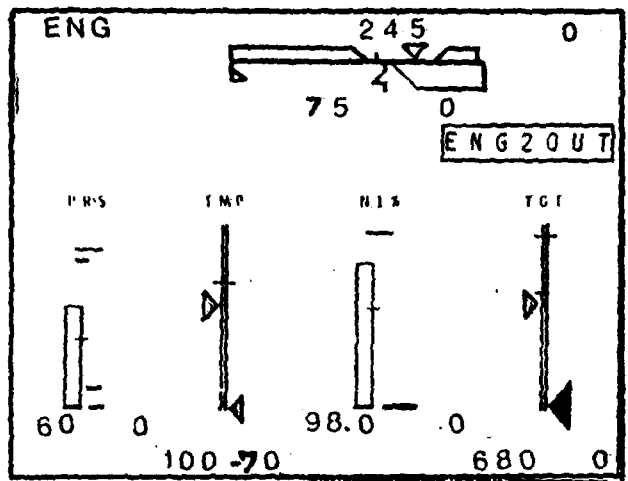

(a)

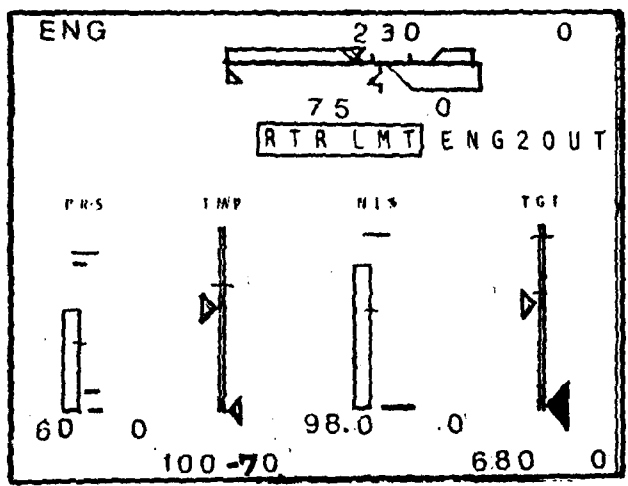

(b)

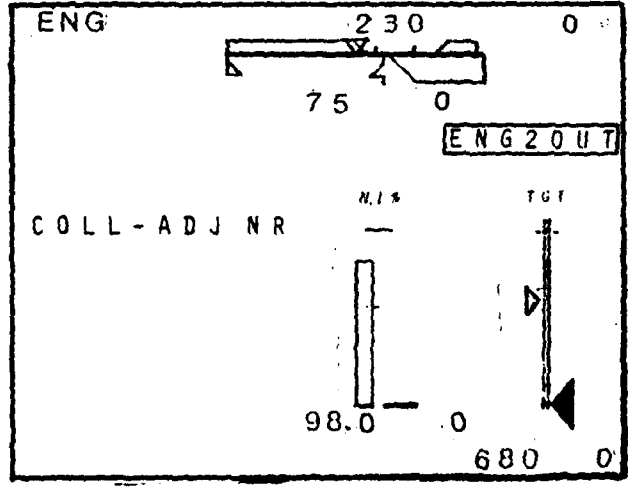

(c)

Figure 3.2.2.3.4

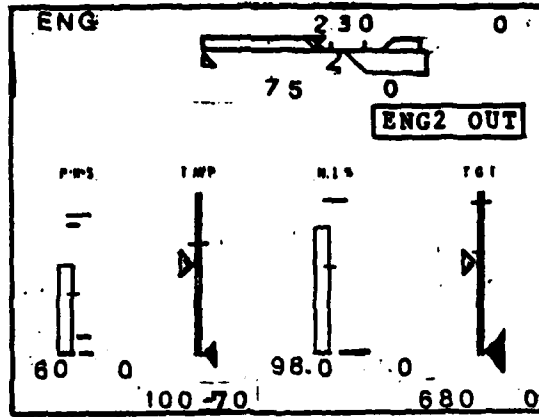

(d)

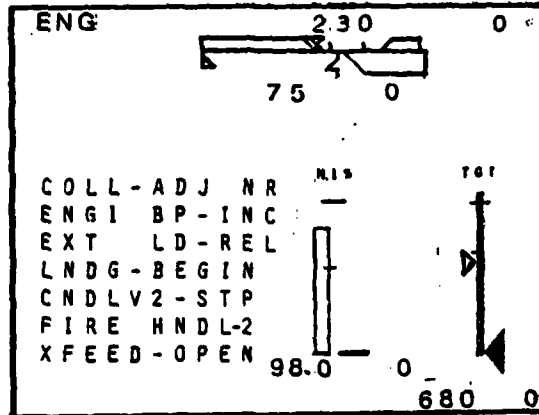

(e)

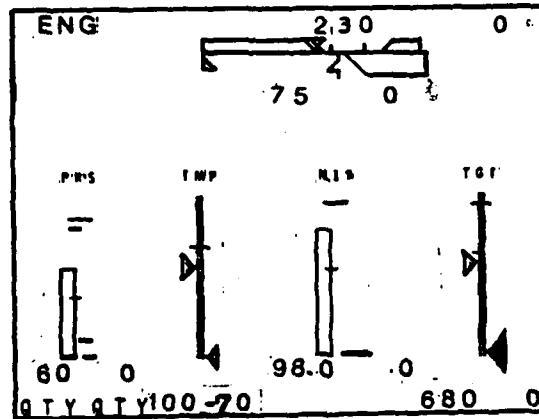

(f)

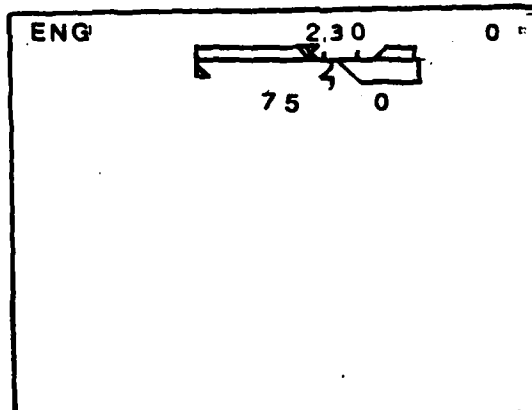

(g)

Figure 3.2.2.3.4 (con't)

TEST NUMBER: 3.2.2.3.5

TITLE: Fault Detection: Display Functions-Timed Parameter Limit Clock.

PURPOSE: Verify proper operation of the Timed Parameter Limit Clock.

HARDWARE CONFIGURATION: All units with standard interconnections.

SOFTWARE REQUIRED: Operational programs for EMMADS and Emulator.

STIMULI: Various test panel inputs. (See Fig. 3.1.3)

INSTRUMENTATION: None.

TEST PROCEDURE:

1. Power up system in normal configuration and compare with Figure 3.2.2.3.1(a).
2. Select the engine subsystem for display using the "ENG DATA" display panel switch.
3. Set the following initial conditions:
  - a. ADIN 02 & 03 = 700 (ENG 1 & 2 TGT)
  - b. ADIN 04 & 05 = 30 (ENG 1 & 2 Torque)
  - c. ADIN 24 = 245 (Rotor RPM)
  - d. DIN 24,25,26 & 27 = 1 (Both cond. levers out of detent)
4. Verification of Timed Parameter Limit Clock proceeds as follows, using Table 3.2.2.3.5:
  - a. With faults enabled (DIN 33=1) and acknowledged, begin each test by changing the test parameter(s) to the indicated value(s).
  - b. At the indicated parameter thresholds, note the initial clock value and label (which occupy the display positions shown in Fig. 3.2.2.3.5) and compare with those indicated in the table.
  - c. When the clock value reaches that shown in the table for test termination, take the indicated action to terminate the test. Unless otherwise specified in the table, if the test concludes with DIN 33=0 (Faults Disabled) reset the test parameter(s) to the initial values in step 3 above before turning DIN 33 back ON for the next test.

TEST NUMBER: 3.2.2.3.5 (con't.)

ACCEPTANCE CRITERIA: The initial clock values and the clock labels shall be as indicated in Table 3.2.2.3.5. In cases where a test is terminated by allowing the countdown clock to time out, the label and scale indicator(s) of the test parameter shall flash until the fault is acknowledged. In certain cases where the word "(nominal)" proceeds the initial clock value for a given test, this indicates that the clock value depends in part on how quickly the test operator can re-adjust the test parameter value from the previous test. The clock time is therefore approximate to within one minute.

TEST HISTORY:

DATE 3-20-81 STATUS OK WITNESS RJK

COUNTDOWN CLOCK

TEST NO	TEST PARAMETER	INCREASE/ DECREASE TO	PARAMETER THRESHOLD	INITIAL CLOCK VALUE	LABEL	CLOCK VALUE	ACTION
1	Eng 1&2 Torque	80 (Seperate)	78±1	00:10	TRQ 1, TRQ 2	00:00	Set ADIN00 = 75% then Acknowledge (DIN 32-1→0) and set ADIN04=80
2		90	85±1	30:00		28:30	Begin Test 3 by increasing torque to given value
3		98	97±1	10:00		8:30	Begin Test 4 by increasing torque to given value
4	Eng 1 Torque	110	100±1	00:10	TRQ 1	:05	Begin Test 5 by decreasing torque to given value
5		98	100±1	8:25 (nominal)		8:00	Begin Test 6 by decreasing torque to given value
6		90	97±1	26:30 (nominal)		26:00	DIN 33=0, ADIN04 & 05 = 30, ADIN01 = 75%
7-11	Eng 2 Torque	(Same as for Tests 2-6 respectively)	(Same as for Tests 2-6 respectively)		TRQ 2	(Same as for Tests 2-6)	(Same as for Tests 2-5 respectively. For Test 11 do not disable faults with DIN33 but begin Test 12)
12	Rotor RPM	253	251±.5	05:00	RTR	04:30	Begin Test 13 by increasing rotor to given value
13	Rotor RPM	260	256±.5	00:05	RTR	00:00	Acknowledge (DIN 32-1→0) then go to Test 14
14	Eng 2 Torque	N/A	N/A	25:25 (nominal)	TRQ 2	24:00	DIN 33=0
15		800	770±1	30:00		28:30	Begin Test 16 by increasing TGT to given value
16		840	810±1	10:00		8:30	Begin Test 17 by increasing TGT to given value
17	Eng 1 TGT	880	860±1	00:02	TGT 1	00:00	Begin Test 18 by decreasing TGT to given value
18		800	810±1	27:00 (nominal)		26:00	DIN 33=0, DIN 14,28 & 30 = 1
22		MAX	788±1	00:04		00:00	DIN 33=0
21-26	ENG 2 TGT	(Same as Tests 15-22 respectively)	(Same as Tests 15-22 respectively)		TGT 2	(Same as for Tests 15-22 respectively)	

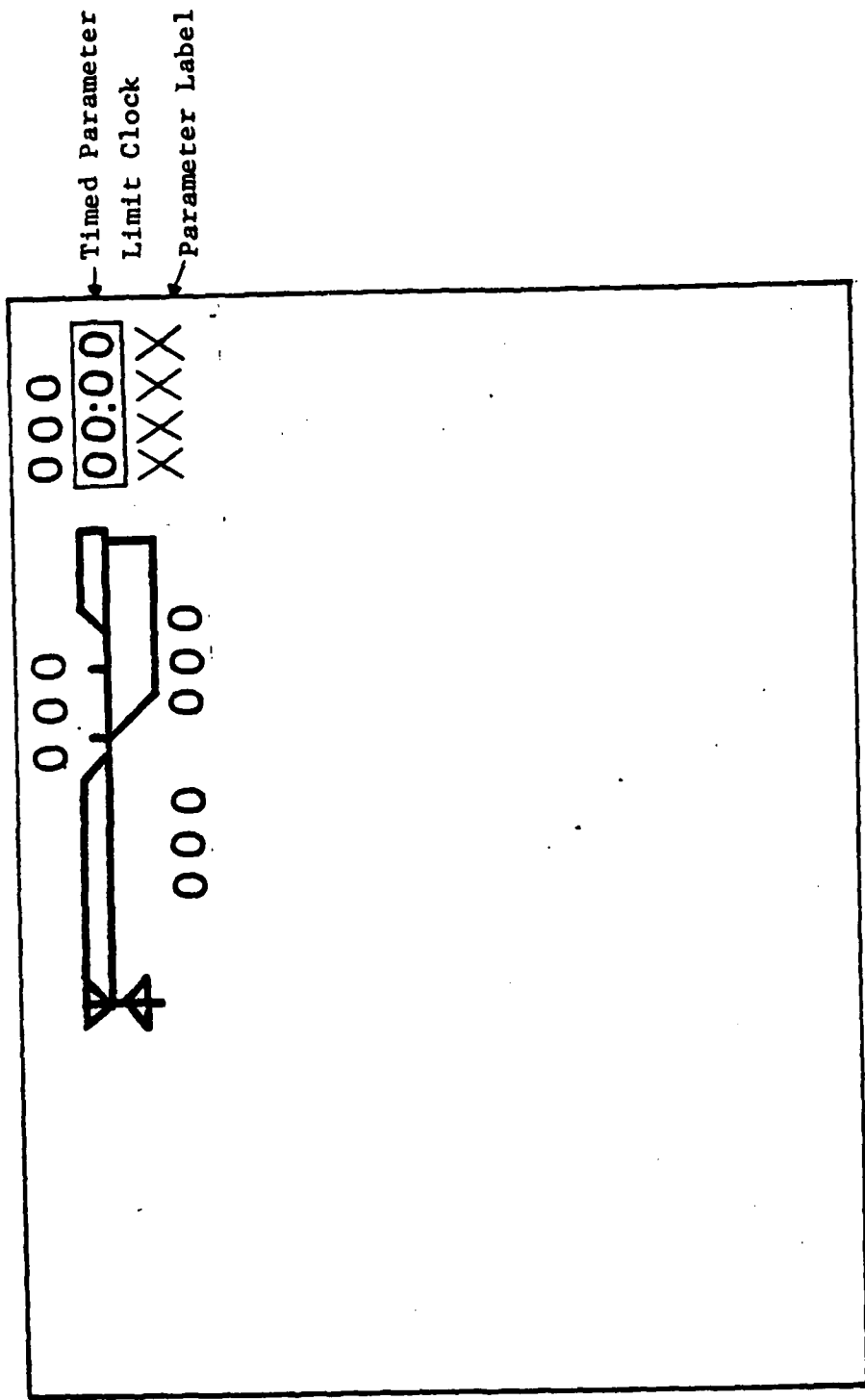

Figure 3.2.2.3.5

DATE  
FILMED

— 8