

AD-A105 334

WOODWARD-CLYDE CONSULTANTS CHICAGO IL  
NATIONAL DAM SAFETY PROGRAM, THE PLACE DAM (NO 30996), MISSISSI--ETC(U)  
DEC 80 S F GIZIENSKI, J PEREZ

F/G 13/13

DACW43-80-C-0066

UNCLASSIFIED

NL

1 of 1  
AD A  
10733A

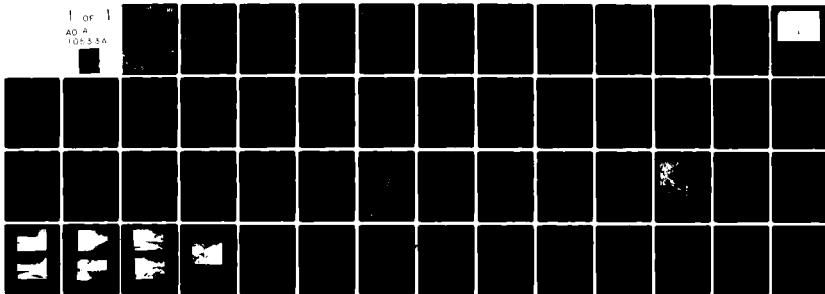

END  
DATE  
FILMED  
11-81  
DTIC

**LEVEL**



**MISSISSIPPI-KASKASKIA-ST. LOUIS BASIN**

AD A 105334

**THE PLACE DAM  
WASHINGTON COUNTY, MISSOURI  
MO 30996**

**DTIC  
ELECTE  
OCT 9 1981  
H**

**PHASE 1 INSPECTION REPORT  
NATIONAL DAM SAFETY INSPECTION**



**United States Army  
Corps of Engineers**  
... Serving the Army  
... Serving the Nation

**St. Louis District**

"Original contains color plates: All DTIC reproductions will be in black and white"

**PREPARED BY: U.S. ARMY ENGINEER DISTRICT, ST. LOUIS**

**FOR: STATE OF MISSOURI**

**DECEMBER 1980**

**DISTRIBUTION STATEMENT A**  
Approved for public release  
Distribution Unlimited

**81 10 8 057**

FILE COPY

UNCLASSIFIED

SECURITY CLASSIFICATION OF THIS PAGE (When Data Entered)

REPORT DOCUMENTATION PAGE		READ INSTRUCTIONS BEFORE COMPLETING FORM
1. REPORT NUMBER	2. GOVT ACCESSION NO.	3. RECIPIENT'S CATALOG NUMBER
	AD-A105334	
4. TITLE (and Subtitle)	5. TYPE OF REPORT & PERIOD COVERED	
Phase I Dam Inspection Report National Dam Safety Program The Place Lake Dam (MO 30996) Washington County, Missouri	(9) Final Report	
7. AUTHOR(s)	6. PERFORMING ORG. REPORT NUMBER	
Woodward-Clyde Consultants		
9. PERFORMING ORGANIZATION NAME AND ADDRESS	8. CONTRACT OR GRANT NUMBER(s)	
U.S. Army Engineer District, St. Louis Dam Inventory and Inspection Section, LMSED-PD 210 Tucker Blvd., North, St. Louis, Mo. 63101	(15) DACW43-80-C-0066	
11. CONTROLLING OFFICE NAME AND ADDRESS	10. PROGRAM ELEMENT, PROJECT, TASK AREA & WORK UNIT NUMBERS	
U.S. Army Engineer District, St. Louis Dam Inventory and Inspection Section, LMSED-PD 210 Tucker Blvd., North, St. Louis, Mo. 63101	(11)	
14. MONITORING AGENCY NAME & ADDRESS (if different from Controlling Office)	12. REPORT DATE	
(10) National Dam Safety Program. The Place Dam (MO 30996), Mississippi - Kaskaskia - St. Louis Basin, Washington County, Missouri. Phase I Inspection Report.	December 80	
	13. NUMBER OF PAGES	
	Approximately 70	
	15. SECURITY CLASS. (of this report)	
	UNCLASSIFIED	
16. DISTR	15a. DECLASSIFICATION/DOWNGRADING SCHEDULE	
Approved for release; distribution unlimited.	(12) 54	
17. DISTRIBUTION STATEMENT (of the abstract entered in Block 20, if different from Report)		
(10) Stanley F/Gizionski; Jean Yves/Porciz		
18. SUPPLEMENTARY NOTES		
19. KEY WORDS (Continue on reverse side if necessary and identify by block number)		
Dam Safety, Lake, Dam Inspection, Private Dams		
20. ABSTRACT (Continue on reverse side if necessary and identify by block number)		
This report was prepared under the National Program of Inspection of Non-Federal Dams. This report assesses the general condition of the dam with respect to safety, based on available data and on visual inspection, to determine if the dam poses hazards to human life or property.		

DD FORM 1473 1 JAN 73

EDITION OF 1 NOV 65 IS OBSOLETE

411445

UNCLASSIFIED  
SECURITY CLASSIFICATION OF THIS PAGE (When Data Entered)

SECURITY CLASSIFICATION OF THIS PAGE(When Data Entered)

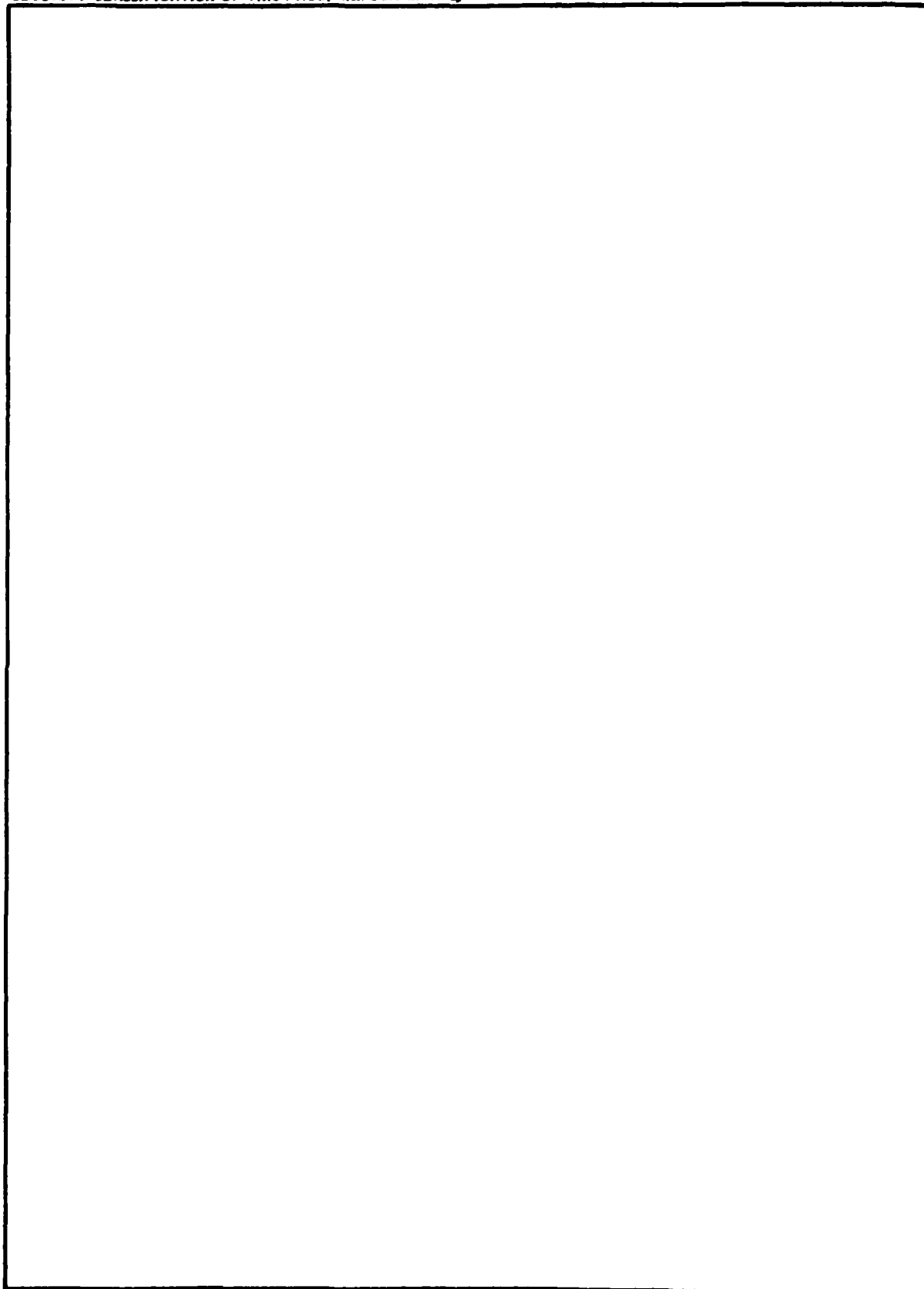

SECURITY CLASSIFICATION OF THIS PAGE(When Data Entered)

## INSTRUCTIONS FOR PREPARATION OF REPORT DOCUMENTATION PAGE

**RESPONSIBILITY.** The controlling DoD office will be responsible for completion of the Report Documentation Page, DD Form 1473, in all technical reports prepared by or for DoD organizations.

**CLASSIFICATION.** Since this Report Documentation Page, DD Form 1473, is used in preparing announcements, bibliographies, and data banks, it should be unclassified if possible. If a classification is required, identify the classified items on the page by the appropriate symbol.

### COMPLETION GUIDE

**General.** Make Blocks 1, 4, 5, 6, 7, 11, 13, 15, and 16 agree with the corresponding information on the report cover. Leave Blocks 2 and 3 blank.

**Block 1.** Report Number. Enter the unique alphanumeric report number shown on the cover.

**Block 2.** Government Accession No. Leave Blank. This space is for use by the Defense Documentation Center.

**Block 3.** Recipient's Catalog Number. Leave blank. This space is for the use of the report recipient to assist in future retrieval of the document.

**Block 4.** Title and Subtitle. Enter the title in all capital letters exactly as it appears on the publication. Titles should be unclassified whenever possible. Write out the English equivalent for Greek letters and mathematical symbols in the title (see "Abstracting Scientific and Technical Reports of Defense-sponsored RDT/E," AD-667 000). If the report has a subtitle, this subtitle should follow the main title, be separated by a comma or semicolon if appropriate, and be initially capitalized. If a publication has a title in a foreign language, translate the title into English and follow the English translation with the title in the original language. Make every effort to simplify the title before publication.

**Block 5.** Type of Report and Period Covered. Indicate here whether report is interim, final, etc., and, if applicable, inclusive dates of period covered, such as the life of a contract covered in a final contractor report.

**Block 6.** Performing Organization Report Number. Only numbers other than the official report number shown in Block 1, such as series numbers for in-house reports or a contractor/grantee number assigned by him, will be placed in this space. If no such numbers are used, leave this space blank.

**Block 7.** Author(s). Include corresponding information from the report cover. Give the name(s) of the author(s) in conventional order (for example, John R. Doe or, if author prefers, J. Robert Doe). In addition, list the affiliation of an author if it differs from that of the performing organization.

**Block 8.** Contract or Grant Number(s). For a contractor or grantee report, enter the complete contract or grant number(s) under which the work reported was accomplished. Leave blank in in-house reports.

**Block 9.** Performing Organization Name and Address. For in-house reports enter the name and address, including office symbol, of the performing activity. For contractor or grantee reports enter the name and address of the contractor or grantee who prepared the report and identify the appropriate corporate division, school, laboratory, etc., of the author. List city, state, and ZIP Code.

**Block 10.** Program Element, Project, Task Area, and Work Unit Numbers. Enter here the number code from the applicable Department of Defense form, such as the DD Form 1498, "Research and Technology Work Unit Summary" or the DD Form 1634, "Research and Development Planning Summary," which identifies the program element, project, task area, and work unit or equivalent under which the work was authorized.

**Block 11.** Controlling Office Name and Address. Enter the full, official name and address, including office symbol, of the controlling office. (Equates to funding/sponsoring agency. For definition see DoD Directive 5200.20, "Distribution Statements on Technical Documents.")

**Block 12.** Report Date. Enter here the day, month, and year or month and year as shown on the cover.

**Block 13.** Number of Pages. Enter the total number of pages.

**Block 14.** Monitoring Agency Name and Address (if different from Controlling Office). For use when the controlling or funding office does not directly administer a project, contract, or grant, but delegates the administrative responsibility to another organization.

**Blocks 15 & 15a.** Security Classification of the Report: Declassification/Downgrading Schedule of the Report. Enter in 15 the highest classification of the report. If appropriate, enter in 15a the declassification/downgrading schedule of the report, using the abbreviations for declassification/downgrading schedules listed in paragraph 4-207 of DoD 5200.1-R.

**Block 16.** Distribution Statement of the Report. Insert here the applicable distribution statement of the report from DoD Directive 5200.20, "Distribution Statements on Technical Documents."

**Block 17.** Distribution Statement (of the abstract entered in Block 20, if different from the distribution statement of the report). Insert here the applicable distribution statement of the abstract from DoD Directive 5200.20, "Distribution Statements on Technical Documents."

**Block 18.** Supplementary Notes. Enter information not included elsewhere but useful, such as: Prepared in cooperation with . . . Translation of (or by) . . . Presented at conference of . . . To be published in . . .

**Block 19.** Key Words. Select terms or short phrases that identify the principal subjects covered in the report, and are sufficiently specific and precise to be used as index entries for cataloging, conforming to standard terminology. The DoD "Thesaurus of Engineering and Scientific Terms" (TEST), AD-672 000, can be helpful.

**Block 20.** Abstract. The abstract should be a brief (not to exceed 200 words) factual summary of the most significant information contained in the report. If possible, the abstract of a classified report should be unclassified and the abstract to an unclassified report should consist of publicly-releasable information. If the report contains a significant bibliography or literature survey, mention it here. For information on preparing abstracts see "Abstracting Scientific and Technical Reports of Defense-Sponsored RDT&E," AD-667 000.



REPLY TO  
ATTENTION OF

**DEPARTMENT OF THE ARMY**  
**ST. LOUIS DISTRICT, CORPS OF ENGINEERS**  
**210 TUCKER BOULEVARD, NORTH**  
**ST. LOUIS, MISSOURI 63104**

**SUBJECT: The Place Dam Phase I Inspection Report**

This report presents the results of field inspection and evaluation of The Place Dam (MO 30996).

It was prepared under the National Program of Inspection of Non-Federal Dams.

This dam has been classified as unsafe, non-emergency by the St Louis District as a result of the application of the following criteria:

- a. The spillways will not pass 50 percent of the Probable Maximum Flood without overtopping the dam.
- b. Overtopping of the dam could result in failure of the dam.
- c. Dam failure significantly increases the hazard to loss of life downstream.

**SIGNED**

SUBMITTED BY: \_\_\_\_\_  
Chief, Engineering Division

**25 FEB 1981**  
Date

**SIGNED**

APPROVED BY: \_\_\_\_\_  
Colonel, CE, District Engineer

**27 FEB 1981**  
Date

Accession #	<input type="checkbox"/>	<input type="checkbox"/>	<input type="checkbox"/>
NTIS GRA&I			
DTIC TAB			
Unannounced			
Justification			
By			
Distribution/			
Availability Codes			
Dist			
			<b>A</b>

**THE PLACE DAM**  
Washington County, Missouri  
Missouri Inventory No. 30996

**Phase I Inspection Report**  
**National Dam Safety Program**

Prepared by

**Woodward-Clyde Consultants**  
Chicago, Illinois

Under Direction of  
St Louis District, Corps of Engineers

for  
Governor of Missouri  
December 1980

## PREFACE

*This report is prepared under guidance contained in the Recommended Guidelines for Safety Inspection of Dams for Phase I Investigations. Copies of these guidelines may be obtained from the Office of the Chief of Engineers, Washington, D. C., 20314. The purpose of a Phase I investigation is not to provide a complete evaluation of the safety of the structure nor to provide a guarantee on its future integrity. Rather the purpose of the program is to identify potentially hazardous conditions to the extent they can be identified by a visual examination. The assessment of the general condition of the dam is based upon available data (if any) and visual inspections. Detailed investigations, testing, and detailed computational evaluations are beyond the scope of a Phase I investigation; however, the investigation is intended to identify the need for more detailed studies. In view of the limited nature of the Phase I studies no assurance can be given that all deficiencies have been identified.*

*In reviewing this report, it should be realized that the reported condition of the dam is based on observations of field conditions at the time of inspection along with any data which may be available to the inspection team. In cases where the reservoir was lowered or drained prior to inspection, such action removes the normal load on the structure, as well as the reservoir head along with seepage pressures, and may obscure certain conditions which might otherwise be detectable if inspected under the normal operating environment of the structure.*

*It is important to note that the condition of a dam depends on numerous and constantly changing internal and external conditions, and is evolutionary in nature. It would be incorrect to assume that the present condition of the dam will continue to represent the condition of the dam at some point in the future. Only through frequent inspections can unsafe conditions be detected, so that corrective action can be taken. Likewise continued care and maintenance are necessary to minimize the possibility of development of unsafe conditions.*

PHASE I REPORT  
NATIONAL DAM SAFETY PROGRAM

Name of Dam	The Place Dam
State Located	Missouri
County Located	Washington
Stream	Unnamed Tributary of Mine à Breton Creek
Date of Inspection	7 August 1980

↓  
The Place Dam, Missouri Inventory No. 30996, was inspected by S.F. Gizienski (geotechnical engineer), R. Juyal (hydrologist) and J. B. Stevens (geotechnical engineer).

The dam inspection was made following the guidelines presented in the "Recommended Guidelines for Safety Inspection of Dams". These guidelines were developed by the Chief of Engineers, U.S. Army, Washington, D.C., with the help of federal and state agencies, professional engineering organizations, and private engineers. The resulting guidelines represent a consensus of the engineering profession. The safety inspections are intended to provide an expeditious identification based on available data and a visual inspection, of those dams which may pose hazards to human life and property. In view of the limited nature of the study, no assurance can be given that all deficiencies have been identified.

↓  
Based on these guidelines, the St Louis District, Corps of Engineers (SLD), has determined that this dam has a high hazard potential; we concur with this classification. The damage zone length, as determined by the St Louis District, Corps of Engineers, extends approximately two miles downstream. Within the damage zone are several occupied dwellings.

The dam is classified as small due to its 180 ac-ft storage volume. The dam height is approximately 16 ft. The small dam classification includes dams having a storage volume between 50 and 1000 ac-ft, or a height between 25 and 40 ft.

Our inspection and evaluation indicate the dam is in generally poor condition. The major deficiencies noted were inadequate spillway capacity, the heavy growth of trees

→

and bushes on the dam, the presence of animal burrows and lack of maintenance and periodic inspections. Seepage and stability analyses comparable to the requirements of the "Recommended Guidelines for Safety Inspection of Dams" were not available, which is considered a deficiency.

Hydrologic/hydraulic studies indicate that a 1 percent probability-of-occurrence event (100 year flood) will not result in overtopping of the dam. These analyses also indicate that the dam will be overtopped for a hydrologic event which produces greater than 40 percent of the Probable Maximum Flood (PMF). The PMF is defined as the flood event that may be expected to occur from the most severe combination of critical meteorologic and hydrologic conditions that are reasonably possible in the region. On the basis of the relatively small impounded volume, the broad downstream valley, and the distance to the nearest structure in the downstream damage zone, 50 percent of the PMF is recommended as the spillway design flood.

The following specific remedial measures and additional studies are recommended for The Place Dam, to be undertaken without undue delay:

1. Prepare a more detailed hydraulic/hydrologic analysis and design a spillway system capable of passing 50 percent of the PMF without overtopping the embankment.
2. A study should be conducted of the Aptus Fault, as described in this report in Section 2.5, Project Geology, to determine the location of the trace of this fault and to evaluate whether or not it represents any potential safety hazard to the dam.

The following measures should be undertaken as soon as practical:

3. Removal of detrimental trees and bushes from the embankment and examination of the animal burrows to detect their effect on the stability of the dam. Removal of large trees should only be done under the guidance of an engineer experienced in the design and construction of earth dams. Indiscriminate clearing could jeopardize the safety of the dam.

4. Performance of seepage and stability analyses in accordance with the requirements of the "Recommended Guidelines for the Safety Inspection of Dams."
5. Evaluation of available options for an effective and practical warning system to alert downstream residents, should potentially hazardous conditions develop at the dam.
6. A program of periodic inspections and maintenance should be implemented for the dam. This program should include but not be limited to the following:
  - a. Inspection of the embankment to identify any signs of slope instability such as slumping or cracking;
  - b. Inspection of the spillways, discharge channels and upstream slope for evidence of serious erosion;
  - c. Maintaining the embankment crest and slopes free of large brush and trees. Removal of large trees should be done under the guidance of an engineer experienced in the design and construction of dams. Indiscriminate clearing could jeopardize the safety of the dam.
  - d. Maintaining the embankment free of animal burrows. A program should be initiated to control further burrowing by animals.
  - e. Keeping maintenance records of recommended and performed maintenance on the facilities;

The analyses and implementation of remedial measures should be performed by an engineer experienced in the design and construction of earth dams.

It is recommended the owner take action on these recommendations as soon as practical to preclude deterioration which could lead to the development of hazardous

conditions at this facility. The action concerning the spillway capacity and the evaluation of the Aptus Fault should be taken without undue delay.

WOODWARD-CLYDE CONSULTANTS

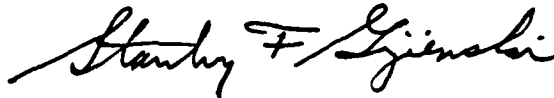

Stanley F. Gizienski, P.E.  
Principal

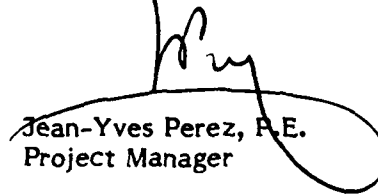

Jean-Yves Perez, P.E.  
Project Manager



**OVERVIEW**

**THE PLACE DAM**

**MISSOURI INVENTORY NUMBER MO. 30998**

PHASE I INSPECTION REPORT  
NATIONAL DAM SAFETY PROGRAM  
THE PLACE DAM, MISSOURI INVENTORY NO. 30996  
TABLE OF CONTENTS

<u>Paragraph No.</u>	<u>Title</u>	<u>Page No.</u>
SECTION 1 - PROJECT INFORMATION		
1.1	General	1
1.2	Description of Project	2
1.3	Pertinent Data	3
SECTION 2 - ENGINEERING DATA		
2.1	Design	6
2.2	Construction	6
2.3	Operation	6
2.4	Evaluation	6
2.5	Project Geology	7
SECTION 3 - VISUAL INSPECTION		
3.1	Findings	8
3.2	Evaluation	9
SECTION 4 - OPERATIONAL PROCEDURES		
4.1	Procedures	11
4.2	Maintenance of Dam	11
4.3	Maintenance of Operating Facilities	11
4.4	Description of any Warning System in Effect	11
4.5	Evaluation	11
SECTION 5 - HYDRAULIC/HYDROLOGIC		
5.1	Evaluation of Features	12

<u>Paragraph No.</u>	<u>Title</u>	<u>Page No.</u>
----------------------	--------------	-----------------

### SECTION 6 - STRUCTURAL STABILITY

6.1	Evaluation of Structural Stability	14
-----	------------------------------------	----

### SECTION 7 - ASSESSMENT/REMEDIAL MEASURES

7.1	Dam Assessment	15
7.2	Remedial Measures	16

REFERENCES		18
------------	--	----

### FIGURES

1.	Site Location Map
2.	Drainage Basin and Site Topography
3A.	Plan, Profile and Sections of Dam, Main Spillway and Discharge Channel
3B.	Section of Auxiliary Spillway and Discharge Channel
4.	Regional Geologic Map

### APPENDICES

#### A Figure A-1: Photo Location Sketch

##### Photographs

1. View along crest from right abutment. Looking west.
2. Upstream slope of dam. Note heavy vegetation and lack of wave protection. Looking west.
3. Downstream slope of dam. Note heavy tree growth. Looking northeast.
4. Entrance to auxiliary spillway at right abutment. Looking north.
5. Entrance to main spillway at left abutment, looking downstream (northwest).
6. Downstream discharge channel for main spillway, looking downstream (north).
7. Wet area at toe of dam near left abutment. Note heavy vegetation. Looking southeast.

#### B Hydraulic/Hydrologic Data and Analyses

**PHASE I INSPECTION REPORT  
NATIONAL DAM SAFETY PROGRAM  
THE PLACE DAM, MISSOURI INVENTORY NO. 30996**

**SECTION I  
PROJECT INFORMATION**

**1.1 General**

- a. **Authority.** The National Dam Inspection Act, Public Law 92-367, provides for a national inventory and inspection of dams throughout the United States. Pursuant to the above, an inspection was conducted of The Place (Mononame 865) Dam, Missouri Inventory Number 30996.
  
- b. **Purpose of inspection.** "The primary purpose of the Phase I investigation program is to identify expeditiously those dams which may pose hazards to human life or property... The Phase I investigation will develop an assessment of the general condition with respect to safety of the project based upon available data and a visual inspection, determine any need for emergency measures and conclude if additional studies, investigations, and analyses are necessary and warranted." (Chapter 3, "Recommended Guidelines for Safety Inspection of Dams").
  
- c. **Evaluation criteria.** The criteria used to evaluate the dam were established in the "Recommended Guidelines for Safety Inspection of Dams", Engineering Regulation No. 1110-2-106 and Engineering Circular No. 1110-2-188, "Engineering and Design National Program for Inspection of Non-Federal Dams", prepared by the Office of Chief of Engineers, Department of the Army, and "Hydrologic/Hydraulic Standards, Phase I Safety Inspection of Non-Federal Dams" prepared by the St Louis District, Corps of Engineers (SLD). These guidelines were developed with the help of several federal agencies and many state agencies, professional engineering organizations, and private engineers.

## 1.2 Description of Project

- a. Description of dam and appurtenances. The Place Dam is a 410 ft long earth dam constructed to form a recreational lake. The main spillway is at the left abutment of the dam and is in unlined earth and uncontrolled. The auxiliary spillway is located at the right abutment and is also in earth and uncontrolled. There are no regulating outlets for the dam.
- b. Location. The dam is on an unnamed tributary of Mine à Breton Creek, about 2.6 mi south of Potosi, Washington County, Missouri. It is located in Sec 26, T37N, R2E, approximately 0.5 mi east of Missouri Hwy P and is shown on the USGS Potosi 7.5-minute quadrangle map (1958).
- c. Size classification. The dam is classified as small due to its 180 ac-ft storage volume. The dam is 16 ft high. The small dam classification includes dams having a storage volume between 50 and 1000 ac-ft, or a height between 25 and 40 ft.
- d. Hazard classification. Based on the applicable guidelines, the St Louis District, Corps of Engineers (SLD), has determined that this dam has a high hazard potential; we concur with this classification. The damage zone length, as determined by the St Louis District, Corps of Engineers, extends approximately two miles downstream. Within the damage zone are several occupied dwellings.
- e. Ownership. We understand the dam is owned by Mr Marvin Boss, Rt 1, Potosi, Missouri 63664. Correspondence should be addressed to his attention.
- f. Purpose of dam. The impoundment is used for recreational purposes.
- g. Design and construction history. According to Mr Boss, the owner, the dam was built between 1963 and 1965 by Mr Webb Allen, Rt 1, Potosi, Missouri. The dam was not formally designed.
- h. Normal operating procedures. No operating records were found. Maximum pool elevation is controlled by the spillway. No other procedures were found to be in effect.

### 1.3 Pertinent Data

a.	<u>Drainage area.</u>	0.76 mi <sup>2</sup>
b.	<u>Discharge at damsite.</u>	
	Maximum known flood at damsite	Within <u>+1</u> ft of dam crest
	Warm water outlet at pool elevation	N/A
	Diversion tunnel low pool outlet at pool elevation	N/A
	Diversion tunnel outlet at pool elevation	N/A
	Gated spillway capacity at pool elevation	N/A
	Gated spillway capacity at maximum pool elevation	N/A
	Ungated spillway capacity at maximum pool elevation	1450 ft <sup>3</sup> /sec
	Total spillway capacity at maximum pool elevation	1450 ft <sup>3</sup> /sec
c.	<u>Elevation (ft above MSL).</u>	
	Top of dam	1051.7 to 1053.1
	Maximum pool-design surcharge	N/A
	Full flood control pool	N/A
	Recreation pool	1047.4
	Spillway crest (gated)	N/A
	Upstream portal invert diversion tunnel	N/A
	Downstream portal invert diversion tunnel	N/A
	Streambed at toe of dam	1036.5
	Maximum tailwater	N/A
d.	<u>Reservoir.</u>	
	Length of maximum pool	1800 ft
	Length of recreation pool	1770 ft
	Length of flood control pool	N/A
e.	<u>Storage (acre-feet).</u>	
	Recreation pool	94

Flood control pool	N/A
Design surcharge	N/A
Top of dam	180

f. Reservoir surface (acres).

Top of dam	22
Maximum pool	22
Flood-control pool	N/A
Recreation pool	17
Spillway crest	17

g. Dam.

Type	Earth fill
Length	410 ft
Height	16
Top width	12 ft
Side slopes	Downstream, 2.6(H) to 1(V) Upstream, 2.6(H) to 3.5(H) to 1(V), to water level
Zoning	Unknown (probably homogeneous)
Impervious core	Unknown
Cutoff	Reportedly 6 ft to shallow rock
Grout curtain	Unknown (probably none)

h. Diversion and regulating tunnel.

Type	None
Length	N/A
Closure	N/A
Access	N/A
Regulating Facilities	N/A

i.1 Main spillway.

Type	Trapezoidal, uncontrolled, unlined earth
------	--

Length of weir	Approximately 78 ft at top Approximately 28 ft at bottom
Crest elevation	1047.4
Gates	None
Upstream Channel	None
Downstream Channel	Unlined earth

i.2 Auxiliary spillway.

Type	"V" shaped, uncontrolled, unlined earth
Length of weir	Approximately 55 ft at elevation of crest of dam
Crest elevation	1049.2
Gates	None
Upstream Channel	None
Downstream Channel	Unlined earth

j. Regulating outlets. None

## SECTION 2 ENGINEERING DATA

### 2.1 Design

No design plans or reports were found for The Place Dam.

### 2.2 Construction

No construction records or data were found.

### 2.3 Operation

There are no records of the history of outflows at the spillway or of the pool elevations. The reservoir elevation is controlled by the elevation of the ungated spillways.

### 2.4 Evaluation

- a. Availability. No engineering design data or construction reports were found for this dam.
- b. Adequacy. Insufficient data were available to determine the adequacy of the design.

Seepage and stability analyses comparable to the requirements of the guidelines are not on record. This is a deficiency which should be rectified. These analyses should be performed for appropriate loading conditions (including earthquake loads) and made a matter of record. These analyses should be conducted by an engineer experienced in the design and construction of earth dams.

- c. Validity. Not applicable.

## 2.5 Project Geology

The dam is located on the northern flank of the Ozark structural dome. The bedrock in the area is mapped on the Geologic Map of Missouri (1979) as Potosi and Eminence dolomite formations (Fig 4). The Potosi Formation consists of siliceous dolomite and typically contains an abundance of quartz druse characteristic of chert bearing formations. The Eminence Formation conformably overlies the Potosi Formation, is similar in appearance but contains less chert and quartz. Some large springs and caves have been noted in the Eminence Formation; however, no evidence of springs or solution activities was noted during the visual inspection of the dam site.

The soil in the vicinity of the dam site is a dark red-brown to tan, plastic residual clay (CL-CH) characteristically developed on the Potosi Formation. The soil also contains abundant quartz druse gravel typical of soils on the Potosi Formation. This residual soil is locally overlain by a thin (2 to 5 ft) loess profile of clayey silt (ML). The soils in this area are mapped on the Missouri General Soils Map as Union-Goss-Gasconade-Peridge Association.

The Aptus Fault is mapped on the Geologic Map of Missouri (1979) as directly beneath the dam (Fig 4). However, the scale of the map (1 in. equals 8 mi) does not allow for precise location of the fault trace. No evidence of the fault was noted during the field inspection. The fault is approximately 15 mi long, trending northwest-southeast. The fault is mapped as northeast side up.

This fault, like others in the Ozark region, appears confined to the Paleozoic bedrock and is likely Paleozoic in age. The area is not considered seismically active. However, the presence of a fault in the immediate vicinity, and perhaps underlying the dam, suggests further study is necessary to evaluate such possible hazards as the potential for groundwater solutioning along the fault in the foundation of this dam.

### SECTION 3 VISUAL INSPECTION

#### 3.1 Findings

- a. General. A visual inspection was made of The Place Dam on 7 August 1980 in the company of Mr Marvin Boss, the reported owner.
- b. Dam. The dam was constructed with a tan, gravelly clay (CL-CH) obtained from the reservoir area. The gravel is an angular chert ranging in size from coarse sand to cobbles.

A dense stand of trees up to 6 in. in diameter is growing on the downstream slope of the dam. On the crest and exposed upstream slope are high bushes and thick grass. There is no riprap on the upstream slope. The upstream slope has had some of the fine-grained portion of the soil winnowed out, leaving gravel close to the water line. Above this line, the slope is grass-covered (Photo 2). Further wave erosion on the upstream slope is likely to occur but is not likely to endanger safety of the dam. This erosion should be monitored as part of a future inspection plan.

Animal burrows, apparently abandoned, were observed at several locations near the water level.

The vertical and horizontal alignment of the dam did not appear disrupted. There was no evidence of sinkhole development, detrimental settlement, cracking, slides or depressions. However the thick vegetative cover made observation difficult so that only gross manifestations of these processes would have been noticeable.

Mr Boss pointed out an area at the dam toe which had been wet before and after the dam was constructed. He believed the area was the exit of a small spring. At the time of inspection the area was wet and spongy and the vegetation was typical of that found in swampy areas (Photo 7). There was no discernible flow.

c. Appurtenant structures.

1. Main spillway. The main spillway is located at the left abutment of the dam (Photo 5). It is unlined, uncontrolled and roughly trapezoidal in shape. Low flows have eroded a narrow channel in the bottom (Photo 6). The gravelly clay soil is considered to be moderately erodible. The narrow channel in the bottom of the spillway is bare, whereas the remainder of the spillway is covered with weedy vegetation and occasional bushes. Erosion of the spillway does not appear to pose a safety hazard to the dam.
  2. Auxiliary spillway. The auxiliary spillway is located at the right abutment. It is also unlined, uncontrolled and roughly "V" notch in shape (Photo 4). The gravelly clay soil is considered to be moderately erodible. Sparse weedy growth covers most of the surface. Erosion of the spillway does not appear to pose a safety hazard to the dam.
- d. Reservoir. The reservoir is used for recreational purposes. Slopes in the area are relatively flat and showed no signs of instability. As the drainage area is heavily wooded (see Overview Photo), there is very little sediment transported into the lake.
- e. Downstream channel. The downstream channels for both spillways are unlined earth. The gravelly clay soil is considered to be moderately erodible. No conditions were noted which would cause reduced capacity in the event of floods. Both discharge channels carry the discharge well away from the dam.

### 3.2 Evaluation

Our visual inspection did not indicate any sinkhole development, detrimental settlement, depressions, slides, cracking or other evidence of instability.

Animal burrows were found at the water level and below the spillway crest elevation. These could become a hazard to the dam.

Although the two spillways and downstream channels may partially erode during heavy flood flows, the erosion does not appear to be a safety hazard to the main body of the dam. However, the erosion may lower the spillway crest elevations, and

reduce the reservoir level correspondingly. Careful monitoring is recommended for this dam.

The wet area at the toe of the dam, which reportedly was in existence prior to the construction of the dam, does not appear to be a safety hazard to the dam at this time. It should be periodically monitored as part of a future inspection program to ensure that any changes that might endanger the safety of the dam are detected.

The heavy vegetative growth on the dam is considered as a potential hazard to the dam. The uprooting of trees, disturbance of the slopes and the decay of root systems may increase the possibility of piping. Also, detection of possible future deformations, cracks or other signs of impending instability may be hindered by the dense vegetative cover. However, the indiscriminate clearing of vegetation can also be a hazard to the dam. Removal of trees, etc., should only be performed under the guidance of an engineer experienced in the design and construction of earth dams.

## SECTION 4 OPERATIONAL PROCEDURES

### 4.1 Procedures

So far as could be determined there are no written operational procedures for this dam. The water level is controlled by the crest of the main spillway.

### 4.2 Maintenance of Dam

No records of maintenance on this facility were available.

### 4.3 Maintenance of Operating Facilities

There are no operating facilities at this dam.

### 4.4 Description of any Warning System in Effect

The inspection did not identify any warning system in effect at this facility.

### 4.5 Evaluation

There are apparently no maintenance or operational procedures in effect. The lack of regular maintenance and periodic inspection is considered a deficiency.

The feasibility of a practical and effective warning system should be evaluated to alert downstream residents, should potentially hazardous conditions develop at the dam during periods of heavy precipitation.

## SECTION 5 HYDRAULIC/HYDROLOGIC

### 5.1 Evaluation of Features

- a. **Design data.** No hydrologic or hydraulic information was available for evaluation of the dam. Pertinent dimensions of the dam and reservoir were surveyed on 12 August 1980, measured during the field inspection, or estimated from topographic mapping. The map used in the analysis was the USGS Potosi 7.5-minute quadrangle map (1958).
- b. **Experience data.** No recorded history of rainfall, runoff, discharge or pool stage data was available for this reservoir or watershed. However, Mr Boss stated that once a 7 to 9-in. rain over a period of about a day, occurred some time after the dam was constructed, causing the reservoir level to rise to within one foot of the top of the dam. At that time, the dam was not overtopped but some erosion of both spillways occurred. Mr Boss further reported the area of the original main spillway was filled and the present spillway excavated further into the left abutment.
- c. **Visual observation.** At the time of inspection, there was no evidence of overtopping. No conditions were noted which could lead to a reduced spillway capacity during a flood occurrence.
- d. **Overtopping potential.** Hydrologic and hydraulic analyses indicate the dam will not be overtopped by the 1 percent probability-of-occurrence event (100-yr flood). These analyses also indicate the spillways can pass only 40 percent of the Probable Maximum Flood (PMF) without overtopping the embankment. The PMF is defined as the flood event that may be expected to occur from the most severe combination of critical meteorologic and hydrologic conditions that are reasonably possible in the region.

The following table presents the expected severity of overtopping for various storm events assuming no erosion in the spillways, or on the embankment:

Percent PMF	Maximum Reservoir Water Surface Elevation, ft (MSL)	Maximum Depth Over Dam, ft	Maximum Outflow, ft <sup>3</sup> sec	Duration of Overtopping, hrs
40	1051.7	0	1450	0
50	1052.2	0.5	1860	1.3
100	1053.2	1.5	3950	4.0

The input data and output summaries for these analyses are presented in Appendix B.

It is likely that some erosion may continue in the spillways during periods of heavy flow, as has been demonstrated in the past. The erosion in the spillway should be controlled and monitored so as to recognize any significant changes which may in the future have an impact on the safety of this dam.

Overtopping of this dam will create a turbulent flow over the downstream face of the dam due to its steepness and vegetative cover. This flow is likely to cause erosion of the embankment, and may cause serious erosion if the overtopping occurs long enough to strip away much of the vegetation. It is felt, however, that if the spillway capacity is increased to safely pass at least 50 percent of the PMF, as recommended in this report, then the remaining potential for depth and duration of overtopping would not be likely to cause failure of this dam, if appropriate vegetative cover is maintained.

## SECTION 6 STRUCTURAL STABILITY

### 6.1 Evaluation of Structural Stability

- a. **Visual inspection.** The visual inspection of The Place Dam revealed no evidence of horizontal or vertical displacement of the dam crest alignment. Cracking, detrimental settlement, slides, depressions or other signs of instability were not observed. No measureable seepage through the embankment, on the downstream slope, or at the toe was observed, although a swampy area was noted.

The gravelly clay soil used to construct the dam is not considered as having a high liquefaction potential.

- b. **Design and construction data.** Design or construction data were not available for the dam or spillways. Seepage and stability analyses comparable to the requirements of the "Recommended Guidelines for Safty Inspection of Dams" were not available. This is considered a deficiency.
- c. **Operating records.** No operating records or water level records are maintained for this facility.
- d. **Post construction changes.** The lack of drawings or construction reports precludes the identification of post construction changes. It was reported by the owner that the original main spillway was filled and a new spillway was excavated farther into the left abutment. There were no other obvious changes observed other than the growth of brush and trees on the embankment.
- e. **Seismic stability.** The dam is in Seismic Zone 2, to which the guidelines assign a moderate damage potential. In view of the gravelly clay used in the construction of the dam, liquefaction is unlikely during a moderate seismic event. However, since soil property data or static stability analyses are not available for review, the seismic stability cannot be properly evaluated.

**SECTION 7**  
**ASSESSMENT/REMEDIAL MEASURES**

**7.1 Dam Assessment**

- a. **Safety.** Based on the visual inspection, The Place Dam is judged to be in generally poor condition. The major deficiencies noted were the inadequate spillway capacity, the heavy vegetative growth on the dam, animal burrows, lack of maintenance and lack of periodic inspections. No signs of instability on the dam were noted, but much of the downstream face of the dam was partially obscured due to heavy vegetative growth.

Seepage and stability analyses comparable to the requirements of the "Recommended Guidelines for Safety Inspection of Dams" were not available. This is considered a deficiency.

- b. **Adequacy of information.** The visual inspection provided a reasonable base of information for the conclusions and recommendations in this Phase I report.

The lack of stability and seepage analyses as recommended in the guidelines preclude an evaluation of the structural and seismic stability of the dam. The lack of stability and seepage analyses is considered a deficiency which should be rectified.

- c. **Urgency.** The deficiencies described in this report could affect the risk of failure of this dam. It is suggested these recommendations be implemented as soon as practical to prevent the development of hazardous conditions. Action on spillway capacity improvements and an evaluation of the Aptus Fault should be taken without undue delay. The remainder of the program outlined in Section 7.2b and 7.2c should be initiated as soon as practical.

- d. **Necessity for Phase II.** In accordance with the "Recommended Guidelines for Safety Inspection of Dams", the subject investigation was a minimum study. This study revealed that additional in-depth investigations, as described in Sec 7.2b, are needed to complete the assessment of the safety of the dam. It

is our understanding from discussions with the St Louis District that these additional in-depth investigations are the responsibility of the owner.

## 7.2 Remedial Measures

- a. **Alternatives.** There are several general options which may be considered to reduce the possibility of dam failure or to diminish the harmful consequences of such a failure. Some of these general options are:
  1. Remove the dam, or breach it to prevent the storage of water.
  2. Increase the height of dam and/or spillway size to pass the Probable Maximum Flood without overtopping the dam.
  3. Purchase downstream land that would be adversely impacted by dam failure and restrict human occupancy.
  4. Provide a highly reliable flood warning system (generally does not prevent damage, but diminishes the chances for loss of life).
- b. **Recommendations.** The following specific remedial measures and additional studies are recommended for The Place Dam, to be undertaken without undue delay:
  1. Prepare a more detailed hydraulic/hydrologic analysis and design a spillway system capable of passing 50 percent of the PMF without overtopping the embankment. The recommended spillway design flood of 50 percent of the PMF is based on the relatively small impoundment volume, the broad downstream valley and the distance to the nearest structure in the downstream damage zone.
  2. A study should be conducted of the Aptus Fault, as described in this report in Section 2.5, Project Geology, to determine the location of the trace of this fault and to evaluate whether or not it represents any potential safety hazard to the dam.

The following measures should be undertaken as soon as practical:

3. Removal of detrimental trees and bushes from the embankment and examination of the animal burrows to detect their effect on the stability of the dam. Removal of large trees should only be done under the guidance of an engineer experienced in the design and construction of earth dams. Indiscriminate clearing could jeopardize the safety of the dam.

4. Performance of seepage and stability analyses in accordance with the requirements of the "Recommended Guidelines for Safety Inspection of Dams".

5. Evaluation of available options for an effective and practical warning system to alert downstream residents, should potentially hazardous conditions develop at the dam.

It is recommended that these remedial measures, analyses and studies be done by, or under the guidance of an engineer experienced in the design and construction of earth dams.

c. **O & M procedures.** A program of periodic inspections and maintenance should be implemented for the dam as soon as practical. This program should include but not be limited to the following:

1. Inspection of the embankment to identify any signs of slope instability such as slumping or cracking;

2. Inspection of the spillways, discharge channels and upstream slope for evidence of serious erosion;

3. Maintaining the embankment crest and slopes free of large brush and trees. Removal of large trees should be done under the guidance of an engineer experienced in the design and construction of dams. Indiscriminate clearing could jeopardize the safety of the dam;

4. Maintaining the embankment free of animal burrows. A program should be initiated to control further burrowing by animals;

5. Keeping maintenance records of recommended and performed maintenance on the facilities.

## REFERENCES

- Allgood, Ferris P., and Persinger, Ivan, D., 1979, "Missouri General Soil Map and Soil Association Descriptions," US Department of Agriculture, Soil Conservation Service and Missouri Agricultural Experiment Station.
- Department of the Army, Office of the Chief of Engineers, 1977, EC 1110-2-188, "National Program of Inspection of Non-Federal Dams".
- Department of the Army, Office of the Chief of Engineers, 1979, ER 1110-2-106, "National Program of Inspection of Non-Federal Dams".
- Hydrologic Engineering Center, US Army Corps of Engineers, 1978, "Flood Hydrograph Package (HEC-1) Users Manual for Dam Safety Investigations".
- McCracken, Mary H., 1971, Structural Features Map of Missouri: Missouri Geological Survey, Scale 1:500,000.
- Missouri Geological Survey, 1979, Geologic Map of Missouri: Missouri Geological Survey, Scale 1:500,000.
- St Louis District, US Army Corps of Engineers, 1979, "Hydrologic/Hydraulic Standards, Phase I Safety Inspection of Non-Federal Dams".
- US Department of Commerce, US Weather Bureau, 1956, "Seasonal Variation of the Probable Maximum Precipitation East of the 105th Meridian for Areas from 10 to 1,000 Square Miles and Durations of 6, 12, 24 and 48 Hours," Hydrometeorological Report No. 33.
- US Soil Conservation Service, 1971, "National Engineering Handbook," Section 4, Hydrology, 1971.



Vicinity Map

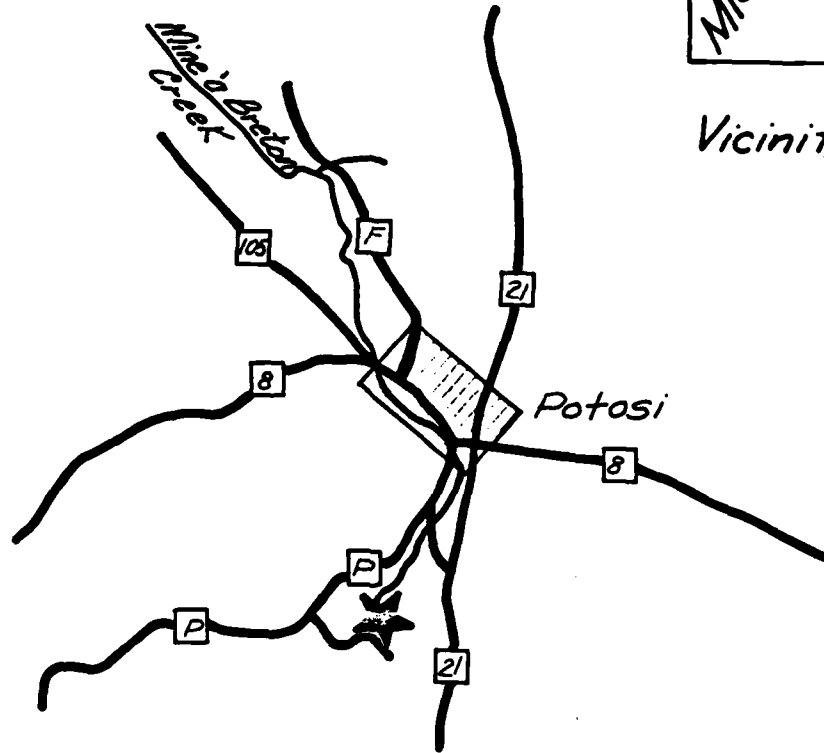

Scale, mile

Legend

-  State highway and Route No.
-  River or Creek
-  City or Town
-  Project location

<b>SITE LOCATION MAP</b>	
THE PLACE DAM	
MO 30996	Fig. 1

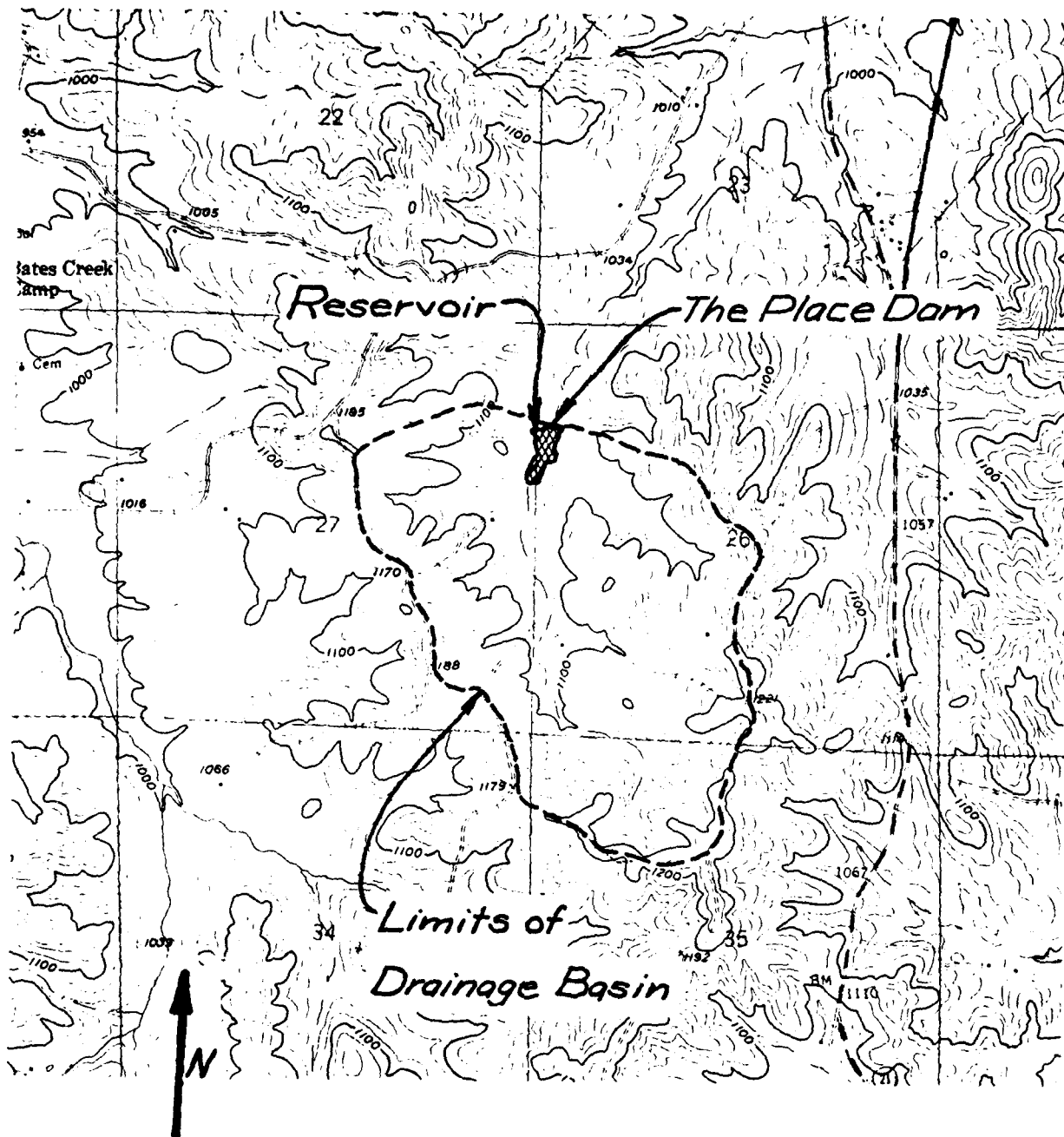

0 2000 4000  
 Scale, ft.

1. Topography from USGS  
 Potosi (1958) 7.5 minute  
 quadrangle map.

DRAINAGE BASIN AND SITE TOPOGRAPHY	
THE PLACE DAM	
MO 30996	Fig. 2

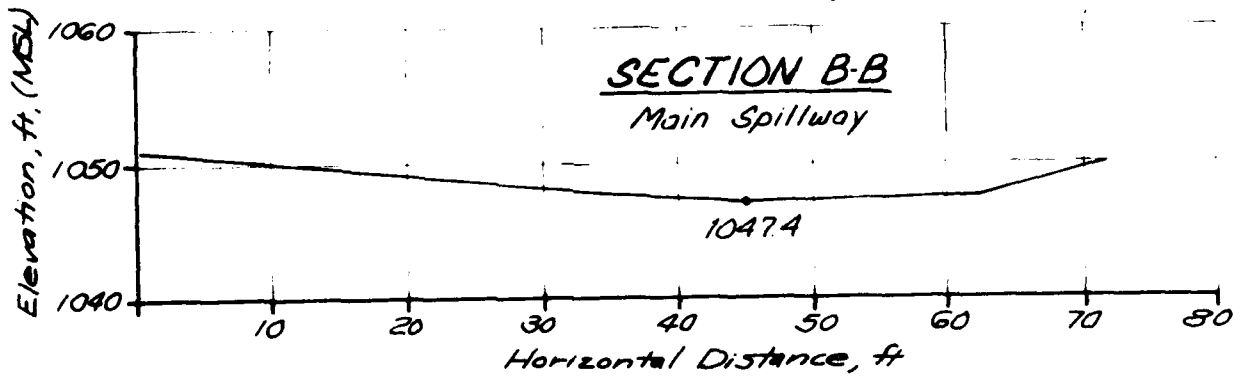
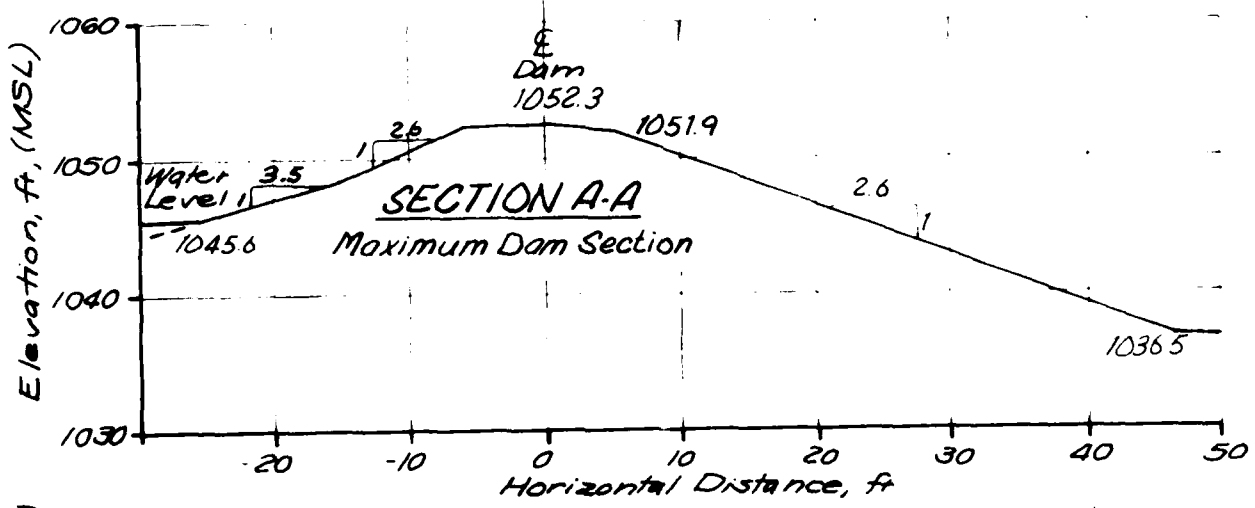
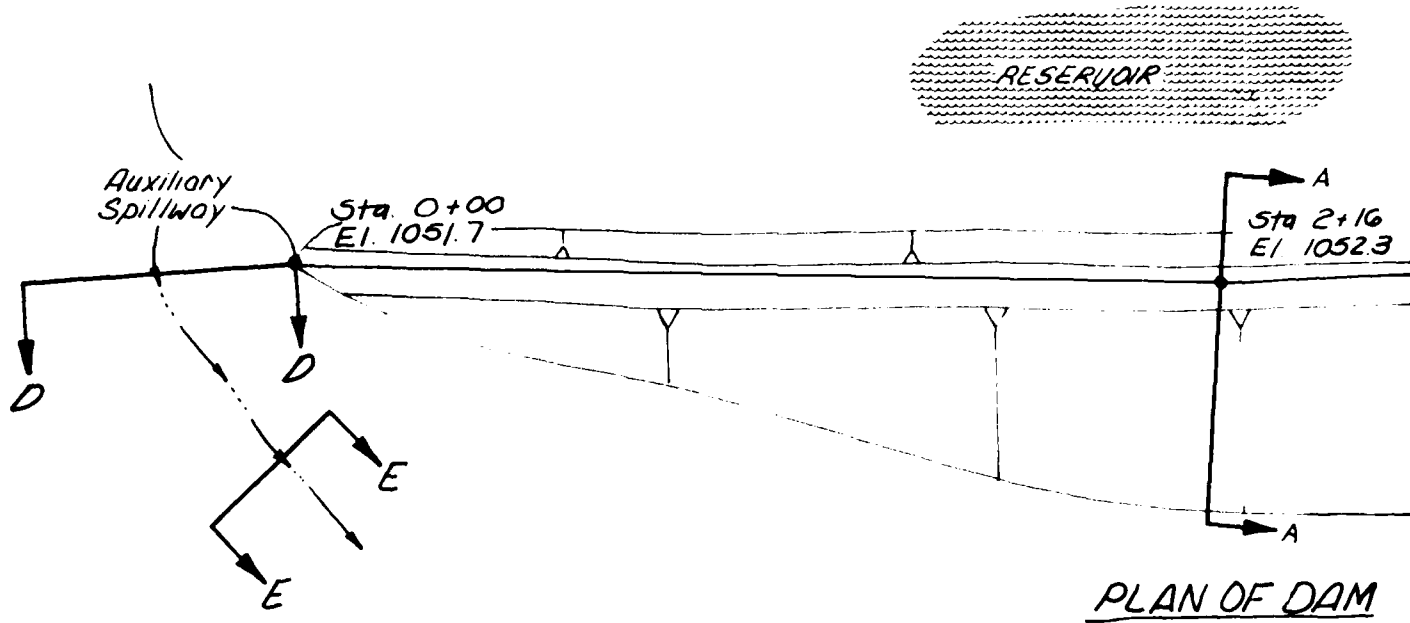

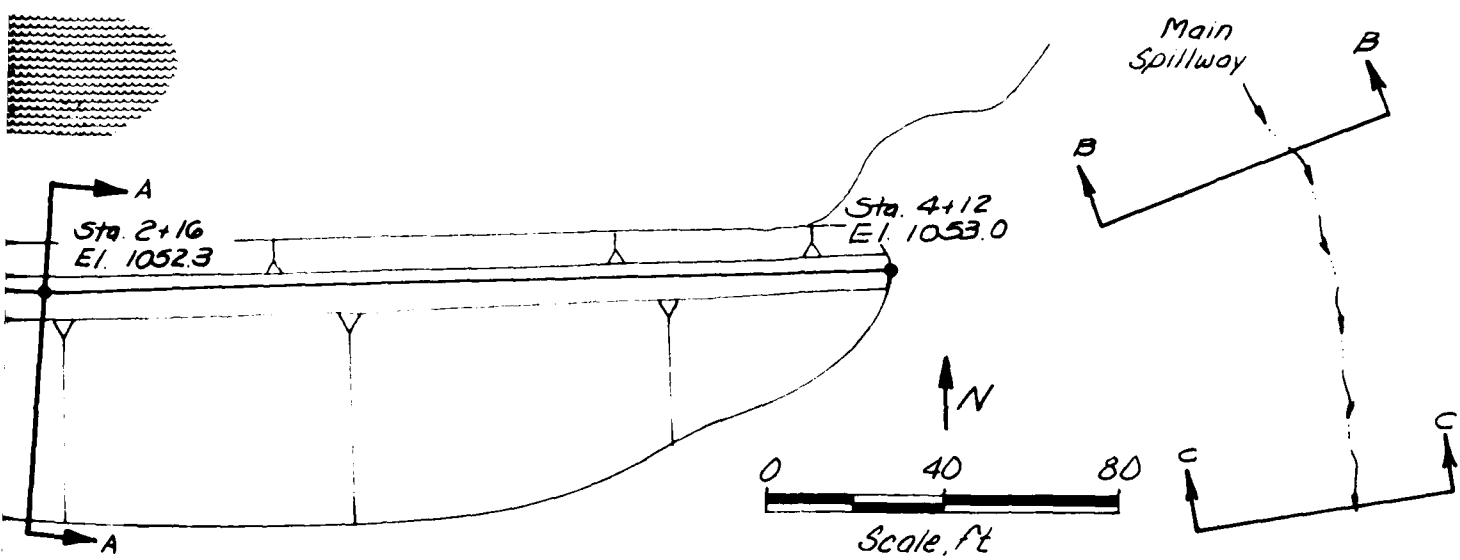

N OF DAM

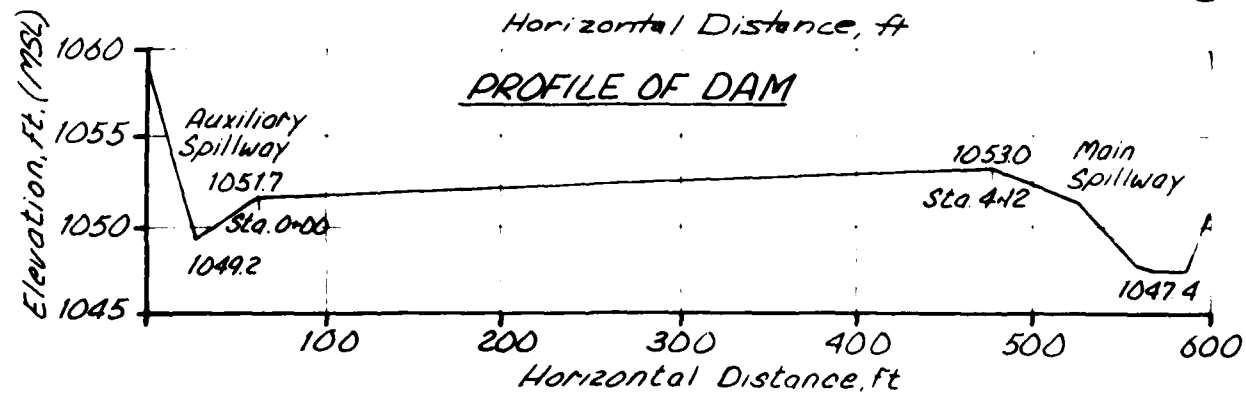
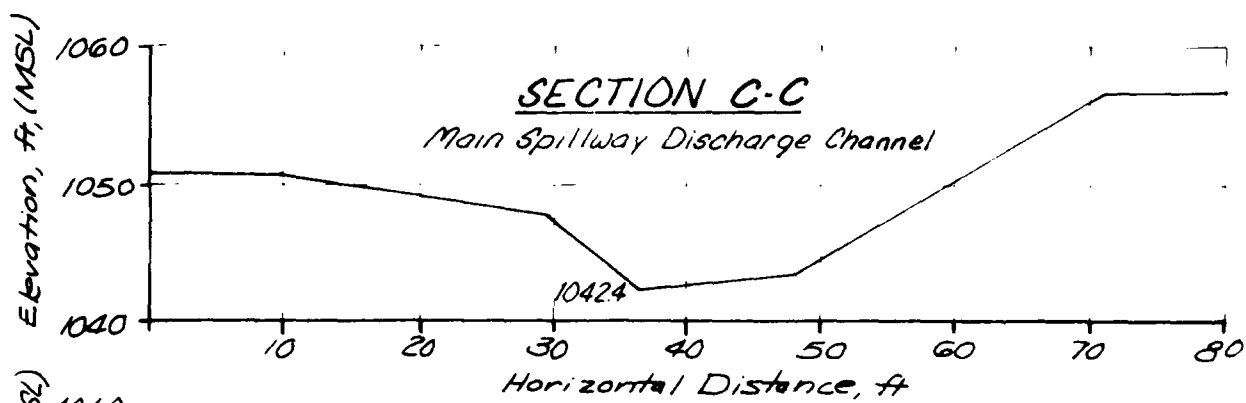

<b>PLAN, PROFILE AND SECTIONS OF DAM, MAIN SPILLWAY AND DISCHARGE CHANNEL</b>	
THE PLACE DAM	
MO 30996	Fig. 3A

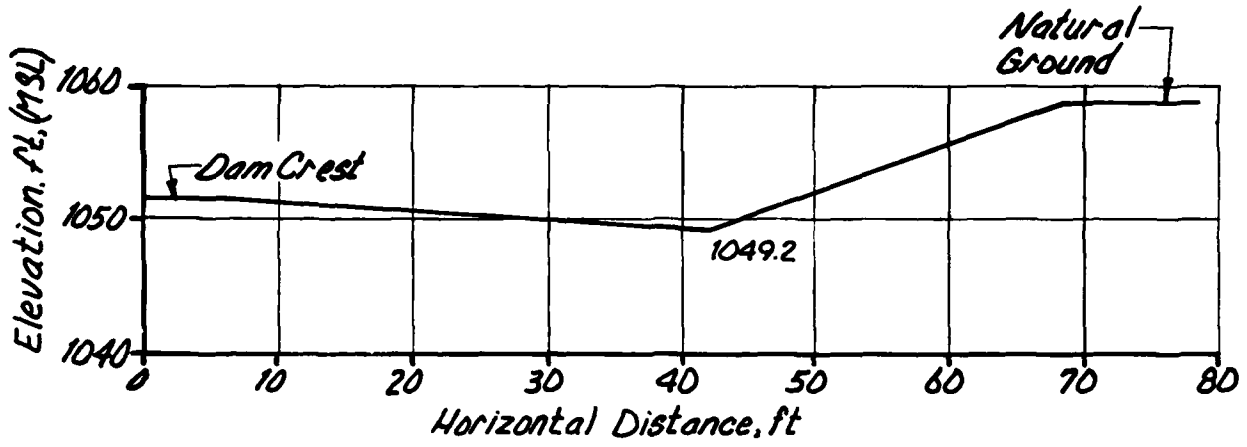

SECTION D-D  
Auxiliary Spillway

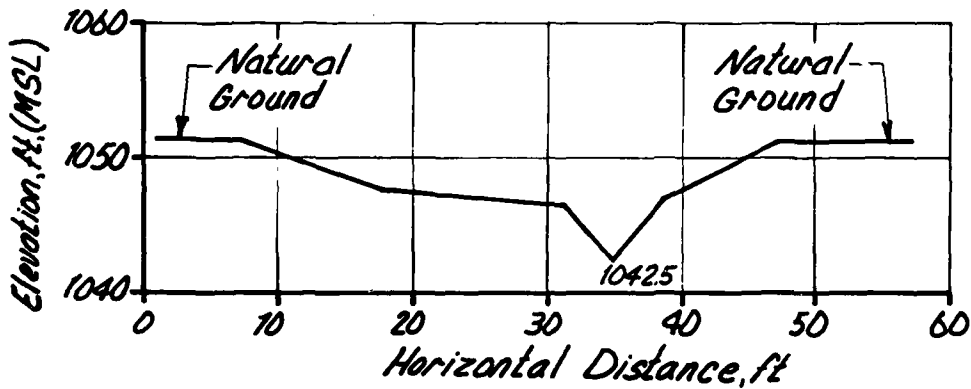

SECTION E-E  
Auxiliary Spillway Discharge Channel

SECTION OF AUXILIARY SPILLWAY AND DISCHARGE CHANNEL	
THE PLACE	
MO. 30996	FIG. 3B

# DAM LOCATION



## Legend

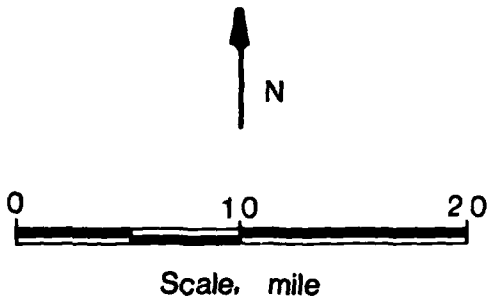
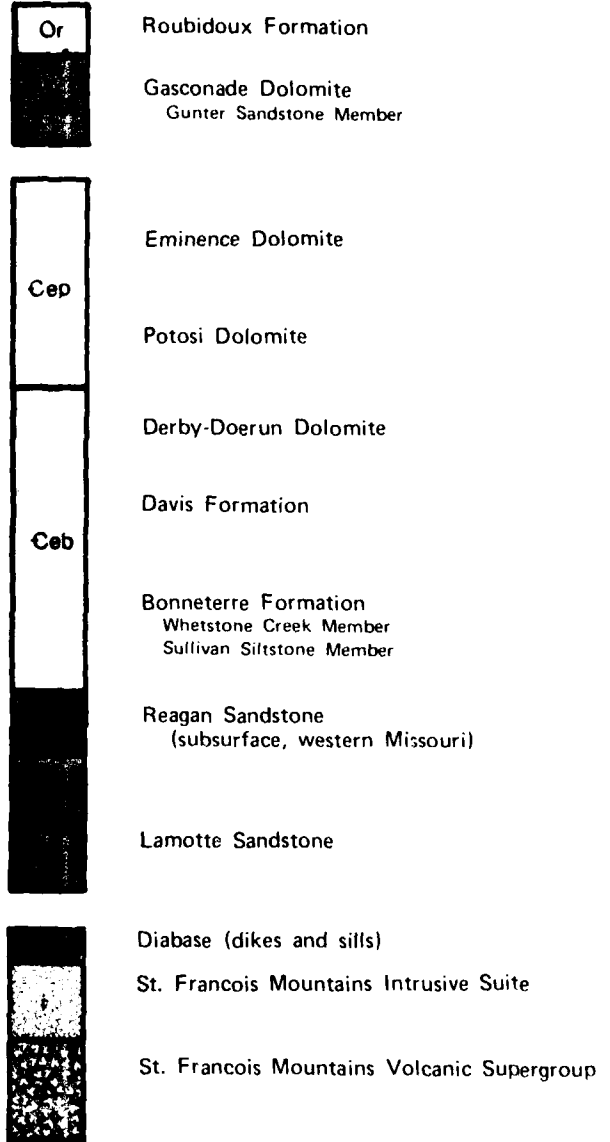

<h1>REGIONAL GEOLOGIC MAP</h1>	
<h2>THE PLACE DAM</h2>	
MO 30996	Fig. 4

**APPENDIX A**  
Photographs

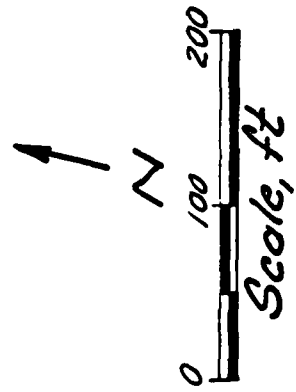
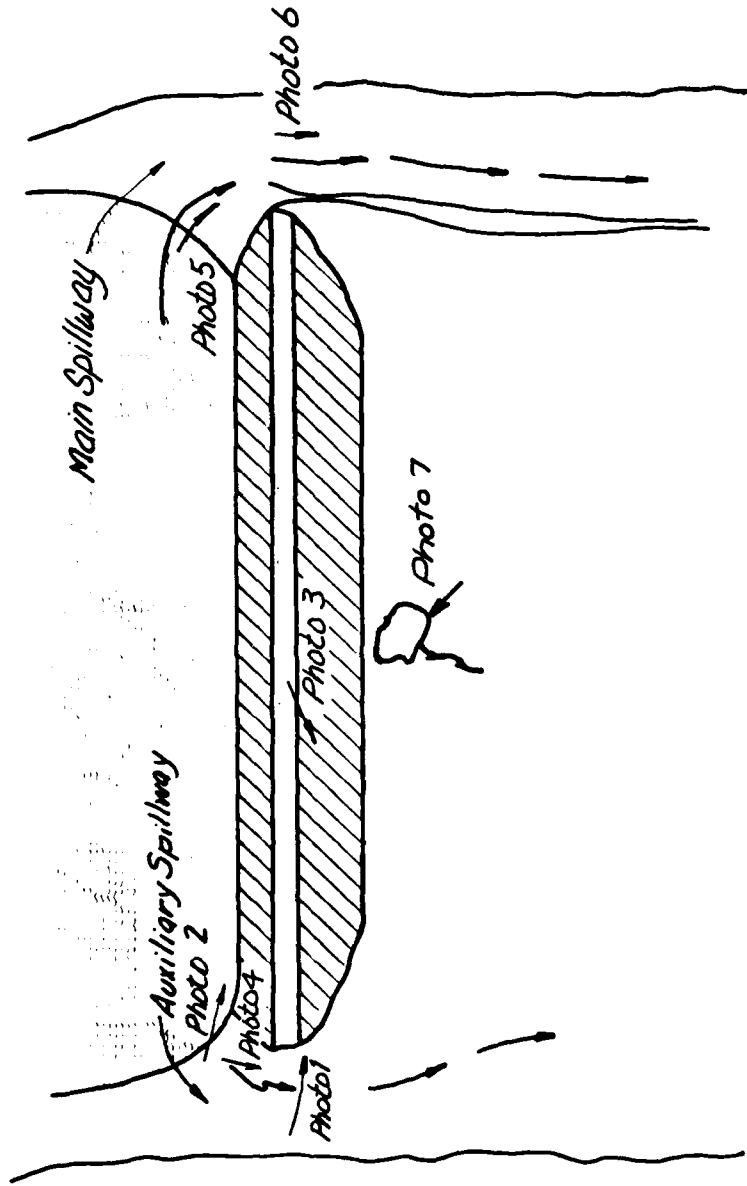

<b>PHOTO LOCATION SKETCH</b>	
THE PLACE DAM	
MO 30996	FIG. A-1



1. View along crest from right abutment. Looking west.



2. Upstream slope of dam. Note heavy vegetation and lack of wave protection. Looking west.



3. Downstream slope of dam. Note heavy tree growth.  
Looking northeast.



4. Entrance to auxiliary spillway at right abutment.  
Looking north.



5. Entrance to main spillway at left abutment looking downstream (northwest).

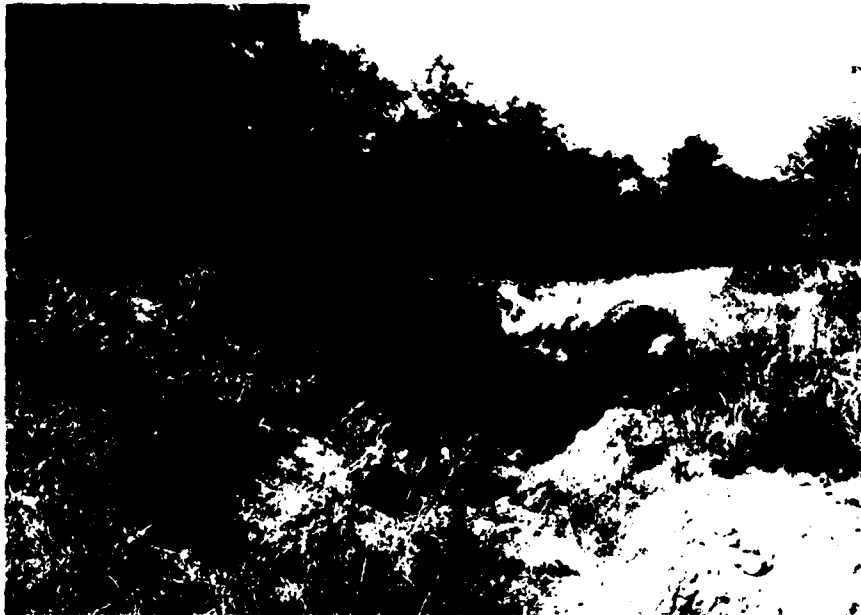

6. Downstream discharge channel for main spillway looking downstream (north).



7. Wet area at toe of dam near left abutment. Note heavy vegetation. Looking southeast.

**APPENDIX B**

Hydraulic/Hydrologic Data and Analyses

APPENDIX B  
Hydraulic/Hydrologic Data and Analyses

B.1 Procedures

- a. General. The hydraulic/hydrologic analyses were performed using the "HEC-1, Dam Safety Version (1 Apr 80)" computer program. The inflow hydrographs were developed for various precipitation events by applying them to a synthetic unit hydrograph. The inflow hydrographs were subsequently routed through the reservoir and appurtenant structures by the modified Puls reservoir routing option.
- b. Precipitation events. The Probable Maximum Precipitation (PMP) and the 1 and 10 percent probability-of-occurrence events were used in the analyses. The total rainfall and corresponding distributions for the 1 and 10 percent probability events were provided by the St. Louis District, Corps of Engineers. The Probable Maximum Precipitation was determined from regional curves prepared by the US Weather Bureau (Hydrometeorological Report Number 33, 1956).
- c. Unit hydrograph. The Soil Conservation Services (SCS) Dimensionless Unit Hydrograph method (National Engineering Handbook, Section 4, Hydrology, 1971) was used in the analysis. This method was selected because of its simplicity, applicability to drainage areas less than 10 mi<sup>2</sup>, and its easy availability within the HEC-1 computer program.

The watershed lag time was computed using the SCS "curve number method" by an empirical relationship as follows:

$$L = \frac{l^{0.8} (s+1)^{0.7}}{1900 Y^{0.5}} \quad \text{(Equation 15-4)}$$

where: L = lag in hours  
l = hydraulic length of the watershed in feet  
s =  $\frac{1000}{CN} - 10$  where CN = hydrologic soil curve number  
Y = average watershed land slope in percent.

This empirical relationship accounts for the soil cover, average watershed slope and hydraulic length.

With the lag time thus computed, another empirical relationship is used to compute the time of concentration as follows:

$$T_c = \frac{L}{0.6} \quad \text{(Equation 15-3)}$$

where: T<sub>c</sub> = time of concentration in hours

L = lag in hours.

Subsequent to the computation of the time of concentration, the unit hydrograph duration was estimated utilizing the following relationship:

$$\Delta D = 0.133T_c \quad (\text{Equation 16-12})$$

where:  $\Delta D$  = duration of unit excess rainfall  
 $T_c$  = time of concentration in hours.

The final interval was selected to provide at least three discharge ordinates prior to the peak discharge ordinate of the unit hydrograph. For this dam, a time interval of 10 minutes was used.

- d. Infiltration losses. The infiltration losses were computed by the HEC-1 computer program internally using the SCS curve number method. The curve numbers were established taking into consideration the variables of: (a) antecedent moisture condition, (b) hydrologic soil group classification, (c) degree of development, (d) vegetative cover and (e) present land usage in the watershed.

Antecedent moisture condition III (AMC III) was used for the PMF events and AMC II was used for the 1 and 10 percent probability events, in accordance with the guidelines. The remaining variables are defined in the SCS procedure and judgements in their selection were made on the basis of visual field inspection.

- e. Starting elevations. Reservoir starting water surface elevations for this dam were set as follows:
- (1) 1 and 10 percent probability events - 1045.6 ft, the reservoir elevation.
  - (2) Probable Maximum Storm - 1047.4 ft, spillway crest elevation.

- f. Spillway Rating Curve.

The elevation/discharge relationship for each spillway was computed by the HEC-2 computer program. These rating curves were then added together and entered on the Y4 and Y5 cards to the HEC-1 program.

## B.2 Pertinent Data

- a. Drainage area. 0.76 mi<sup>2</sup>
- b. Storm duration. A unit hydrograph was developed by the SCS method option of HEC-1 program. The design storm of 48 hours duration was divided into 10 minute intervals in order to develop the inflow hydrograph.
- c. Lag time. 0.9 hrs
- d. Hydrologic soil group. C

- e. SCS curve numbers.
  - 1. For PMF- AMC III - Curve Number 86
  - 2. For 1 and 10 percent probability-of-occurrence events-AMC II - Curve Number 71
- f. Storage. Elevation-area data were developed by planimetering areas at various elevation contours on the USGS Potosi 7.5-minute quadrangle map (1958). The data were entered on the \$A and \$E cards so that the HEC-1 program could compute storage volumes.
- g. Outflow over dam crest. As the profile of the dam crest is irregular, flow over the crest was computed according to the "Flow Over Non-Level Dam Crest" supplement to the HEC-1 User's Manual. The crest length-elevation data and hydraulic constants were entered on the \$D, \$L, and \$V cards.
- h. Outflow capacity. Each spillway rating curve was computed by the method described in Section B.1f and added together and the pertinent data was entered on the Y4 and Y5 cards.
- i. Reservoir elevations. For the 50 and 100 percent of the PMF events, the starting reservoir elevation was 1047.4 ft, the spillway crest elevation. For the 1 and 10 percent probability-of-occurrence events, the starting reservoir elevation was 1045.6 ft, the reservoir water elevation.

### B.3 Results

The results of the analyses as well as the input values to the HEC-1 program follow in this Appendix. Only the results summaries are included, not the intermediate output. Complete copies of the HEC-1 output are available in the project files.



\*\*\*\*\*  
 P-LOAD HYDROGRAPH PACKAGE (HEC-1)  
 DAM SAFETY VERSION JULY 1978  
 LAST MODIFICATION 01 APR 80  
 \*\*\*\*\*

\*\*\*\*\*  
 RUN DATES 16 DEC 80  
 TIME 14:35:39  
 \*\*\*\*\*

THE PLACE LAKE DAM NO. 30996  
 WOODWARD-CLYDE CONSULTANTS, HOUSTON JOB NO. 79CM009  
 PROBABE WATTHON PCOV TPMPY ANALYSIS

NO MNR MMIN IDAY IMR IMIN METRC IPLY IPRT MSTAN  
 208 0 10 JOPER MNT LROPT TRACE  
 JOB SPECIFICATION

MULTI-PLAN ANALYSES TO BE PERFORMED  
 PLAN= 1 MRTIO= 4 LRTIO= 1  
 RTIOS= .25 .50 .75 1.00

\*\*\*\*\*  
 SUB-AREA RUNOFF COMPUTATION  
 \*\*\*\*\*

THE PLACE LAKE INFLOW COMPUTATIONS

ISFNO ICOMP IEGON ITAPE JPLY JPRT INAME ISTAGE INOTO  
 LAKE 0 -0 -0 -0 -0 -0 1 -0 -0

HYDROGRAPH DATA

INVOG IUMG TAREA SNAP TRSDA TRSPC RATIO ISNOW ISAME LOCAL  
 1 2 .76 -0. .76 1.00 -0.

PRECIP DATA

SPFE PMS R6 R12 R24 R48 R72 R96  
 0. 20.00 102.00 120.00 130.00 140.00 -0. -0.

LOSS DATA

CRPT STARR DELTR RTIOC ERATN STKRS RTYOK STKTL CNSTL ALSMX RTIMP  
 -0 -0. -0. 1.00 -0. -0. 1.00 -1.00 -71.00 -0. .03

CURVE NO = 71.00 METRESS = 1.00 EFFECT CN = 71.00

UNIT HYDROGRAPH DATA

IC=0. LAG=.90

RECESSION DATA

STRFO= -1.00 ORCSM= .09 RTTOR= 5.00

UNIT HYDROGRAPH 29 END OF PERIOD ORIGINATES, IC= -0. HOURS, LAG= .90 VOL= 1.00  
 29. 88. 102. 299. 358. 373. 395. 405. 243. 174.  
 131. 100. 77. 58. 44. 34. 25. 19. 15. 11.  
 8. 6. 5. 4. 3. 2. 2. 1. 0.

Output Summary  
 Various PMF Events  
 The Place Dam  
 MO 30996

B5

UNIT HYDROGRAPH 24 ENU UP PERIOD URDINATES, TC= -0. HOURS, LAG= .90 VOL= 1.00  
 24. 88. 182. 243. 305. 350. 395. 440. 485. 530. 575. 620. 665. 710. 755. 800. 845. 890. 935. 980. 1025. 1070. 1115. 1160. 1205. 1250. 1295. 1340. 1385. 1430. 1475. 1520. 1565. 1610. 1655. 1700. 1745. 1790. 1835. 1880. 1925. 1970. 2015. 2060. 2105. 2150. 2195. 2240. 2285. 2330. 2375. 2420. 2465. 2510. 2555. 2600. 2645. 2690. 2735. 2780. 2825. 2870. 2915. 2960. 3005. 3050. 3095. 3140. 3185. 3230. 3275. 3320. 3365. 3410. 3455. 3500. 3545. 3590. 3635. 3680. 3725. 3770. 3815. 3860. 3905. 3950. 3995. 4040. 4085. 4130. 4175. 4220. 4265. 4310. 4355. 4400. 4445. 4490. 4535. 4580. 4625. 4670. 4715. 4760. 4805. 4850. 4895. 4940. 4985. 5030. 5075. 5120. 5165. 5210. 5255. 5300. 5345. 5390. 5435. 5480. 5525. 5570. 5615. 5660. 5705. 5750. 5795. 5840. 5885. 5930. 5975. 6020. 6065. 6110. 6155. 6200. 6245. 6290. 6335. 6380. 6425. 6470. 6515. 6560. 6605. 6650. 6695. 6740. 6785. 6830. 6875. 6920. 6965. 7010. 7055. 7100. 7145. 7190. 7235. 7280. 7325. 7370. 7415. 7460. 7505. 7550. 7595. 7640. 7685. 7730. 7775. 7820. 7865. 7910. 7955. 8000. 8045. 8090. 8135. 8180. 8225. 8270. 8315. 8360. 8405. 8450. 8495. 8540. 8585. 8630. 8675. 8720. 8765. 8810. 8855. 8900. 8945. 8990. 9035. 9080. 9125. 9170. 9215. 9260. 9305. 9350. 9395. 9440. 9485. 9530. 9575. 9620. 9665. 9710. 9755. 9800. 9845. 9890. 9935. 9980. 10025. 10070. 10115. 10160. 10205. 10250. 10295. 10340. 10385. 10430. 10475. 10520. 10565. 10610. 10655. 10700. 10745. 10790. 10835. 10880. 10925. 10970. 11015. 11060. 11105. 11150. 11195. 11240. 11285. 11330. 11375. 11420. 11465. 11510. 11555. 11600. 11645. 11690. 11735. 11780. 11825. 11870. 11915. 11960. 12005. 12050. 12095. 12140. 12185. 12230. 12275. 12320. 12365. 12410. 12455. 12500. 12545. 12590. 12635. 12680. 12725. 12770. 12815. 12860. 12905. 12950. 12995. 13040. 13085. 13130. 13175. 13220. 13265. 13310. 13355. 13400. 13445. 13490. 13535. 13580. 13625. 13670. 13715. 13760. 13805. 13850. 13895. 13940. 13985. 14030. 14075. 14120. 14165. 14210. 14255. 14300. 14345. 14390. 14435. 14480. 14525. 14570. 14615. 14660. 14705. 14750. 14795. 14840. 14885. 14930. 14975. 15020. 15065. 15110. 15155. 15200. 15245. 15290. 15335. 15380. 15425. 15470. 15515. 15560. 15605. 15650. 15695. 15740. 15785. 15830. 15875. 15920. 15965. 16010. 16055. 16100. 16145. 16190. 16235. 16280. 16325. 16370. 16415. 16460. 16505. 16550. 16595. 16640. 16685. 16730. 16775. 16820. 16865. 16910. 16955. 17000. 17045. 17090. 17135. 17180. 17225. 17270. 17315. 17360. 17405. 17450. 17495. 17540. 17585. 17630. 17675. 17720. 17765. 17810. 17855. 17900. 17945. 17990. 18035. 18080. 18125. 18170. 18215. 18260. 18305. 18350. 18395. 18440. 18485. 18530. 18575. 18620. 18665. 18710. 18755. 18800. 18845. 18890. 18935. 18980. 19025. 19070. 19115. 19160. 19205. 19250. 19295. 19340. 19385. 19430. 19475. 19520. 19565. 19610. 19655. 19700. 19745. 19790. 19835. 19880. 19925. 19970. 20015. 20060. 20105. 20150. 20195. 20240. 20285. 20330. 20375. 20420. 20465. 20510. 20555. 20600. 20645. 20690. 20735. 20780. 20825. 20870. 20915. 20960. 21005. 21050. 21095. 21140. 21185. 21230. 21275. 21320. 21365. 21410. 21455. 21500. 21545. 21590. 21635. 21680. 21725. 21770. 21815. 21860. 21905. 21950. 21995. 22040. 22085. 22130. 22175. 22220. 22265. 22310. 22355. 22400. 22445. 22490. 22535. 22580. 22625. 22670. 22715. 22760. 22805. 22850. 22895. 22940. 22985. 23030. 23075. 23120. 23165. 23210. 23255. 23300. 23345. 23390. 23435. 23480. 23525. 23570. 23615. 23660. 23705. 23750. 23795. 23840. 23885. 23930. 23975. 24020. 24065. 24110. 24155. 24200. 24245. 24290. 24335. 24380. 24425. 24470. 24515. 24560. 24605. 24650. 24695. 24740. 24785. 24830. 24875. 24920. 24965. 25010. 25055. 25100. 25145. 25190. 25235. 25280. 25325. 25370. 25415. 25460. 25505. 25550. 25595. 25640. 25685. 25730. 25775. 25820. 25865. 25910. 25955. 26000. 26045. 26090. 26135. 26180. 26225. 26270. 26315. 26360. 26405. 26450. 26495. 26540. 26585. 26630. 26675. 26720. 26765. 26810. 26855. 26900. 26945. 26990. 27035. 27080. 27125. 27170. 27215. 27260. 27305. 27350. 27395. 27440. 27485. 27530. 27575. 27620. 27665. 27710. 27755. 27800. 27845. 27890. 27935. 27980. 28025. 28070. 28115. 28160. 28205. 28250. 28295. 28340. 28385. 28430. 28475. 28520. 28565. 28610. 28655. 28700. 28745. 28790. 28835. 28880. 28925. 28970. 29015. 29060. 29105. 29150. 29195. 29240. 29285. 29330. 29375. 29420. 29465. 29510. 29555. 29600. 29645. 29690. 29735. 29780. 29825. 29870. 29915. 29960. 30005. 30050. 30095. 30140. 30185. 30230. 30275. 30320. 30365. 30410. 30455. 30500. 30545. 30590. 30635. 30680. 30725. 30770. 30815. 30860. 30905. 30950. 30995. 31040. 31085. 31130. 31175. 31220. 31265. 31310. 31355. 31400. 31445. 31490. 31535. 31580. 31625. 31670. 31715. 31760. 31805. 31850. 31895. 31940. 31985. 32030. 32075. 32120. 32165. 32210. 32255. 32300. 32345. 32390. 32435. 32480. 32525. 32570. 32615. 32660. 32705. 32750. 32795. 32840. 32885. 32930. 32975. 33020. 33065. 33110. 33155. 33200. 33245. 33290. 33335. 33380. 33425. 33470. 33515. 33560. 33605. 33650. 33695. 33740. 33785. 33830. 33875. 33920. 33965. 34010. 34055. 34100. 34145. 34190. 34235. 34280. 34325. 34370. 34415. 34460. 34505. 34550. 34595. 34640. 34685. 34730. 34775. 34820. 34865. 34910. 34955. 35000. 35045. 35090. 35135. 35180. 35225. 35270. 35315. 35360. 35405. 35450. 35495. 35540. 35585. 35630. 35675. 35720. 35765. 35810. 35855. 35900. 35945. 35990. 36035. 36080. 36125. 36170. 36215. 36260. 36305. 36350. 36395. 36440. 36485. 36530. 36575. 36620. 36665. 36710. 36755. 36800. 36845. 36890. 36935. 36980. 37025. 37070. 37115. 37160. 37205. 37250. 37295. 37340. 37385. 37430. 37475. 37520. 37565. 37610. 37655. 37700. 37745. 37790. 37835. 37880. 37925. 37970. 38015. 38060. 38105. 38150. 38195. 38240. 38285. 38330. 38375. 38420. 38465. 38510. 38555. 38600. 38645. 38690. 38735. 38780. 38825. 38870. 38915. 38960. 39005. 39050. 39095. 39140. 39185. 39230. 39275. 39320. 39365. 39410. 39455. 39500. 39545. 39590. 39635. 39680. 39725. 39770. 39815. 39860. 39905. 39950. 39995. 40040. 40085. 40130. 40175. 40220. 40265. 40310. 40355. 40400. 40445. 40490. 40535. 40580. 40625. 40670. 40715. 40760. 40805. 40850. 40895. 40940. 40985. 41030. 41075. 41120. 41165. 41210. 41255. 41300. 41345. 41390. 41435. 41480. 41525. 41570. 41615. 41660. 41705. 41750. 41795. 41840. 41885. 41930. 41975. 42020. 42065. 42110. 42155. 42200. 42245. 42290. 42335. 42380. 42425. 42470. 42515. 42560. 42605. 42650. 42695. 42740. 42785. 42830. 42875. 42920. 42965. 43010. 43055. 43100. 43145. 43190. 43235. 43280. 43325. 43370. 43415. 43460. 43505. 43550. 43595. 43640. 43685. 43730. 43775. 43820. 43865. 43910. 43955. 44000. 44045. 44090. 44135. 44180. 44225. 44270. 44315. 44360. 44405. 44450. 44495. 44540. 44585. 44630. 44675. 44720. 44765. 44810. 44855. 44900. 44945. 44990. 45035. 45080. 45125. 45170. 45215. 45260. 45305. 45350. 45395. 45440. 45485. 45530. 45575. 45620. 45665. 45710. 45755. 45800. 45845. 45890. 45935. 45980. 46025. 46070. 46115. 46160. 46205. 46250. 46295. 46340. 46385. 46430. 46475. 46520. 46565. 46610. 46655. 46700. 46745. 46790. 46835. 46880. 46925. 46970. 47015. 47060. 47105. 47150. 47195. 47240. 47285. 47330. 47375. 47420. 47465. 47510. 47555. 47600. 47645. 47690. 47735. 47780. 47825. 47870. 47915. 47960. 48005. 48050. 48095. 48140. 48185. 48230. 48275. 48320. 48365. 48410. 48455. 48500. 48545. 48590. 48635. 48680. 48725. 48770. 48815. 48860. 48905. 48950. 48995. 49040. 49085. 49130. 49175. 49220. 49265. 49310. 49355. 49400. 49445. 49490. 49535. 49580. 49625. 49670. 49715. 49760. 49805. 49850. 49895. 49940. 49985. 50030. 50075. 50120. 50165. 50210. 50255. 50300. 50345. 50390. 50435. 50480. 50525. 50570. 50615. 50660. 50705. 50750. 50795. 50840. 50885. 50930. 50975. 51020. 51065. 51110. 51155. 51200. 51245. 51290. 51335. 51380. 51425. 51470. 51515. 51560. 51605. 51650. 51695. 51740. 51785. 51830. 51875. 51920. 51965. 52010. 52055. 52100. 52145. 52190. 52235. 52280. 52325. 52370. 52415. 52460. 52505. 52550. 52595. 52640. 52685. 52730. 52775. 52820. 52865. 52910. 52955. 53000. 53045. 53090. 53135. 53180. 53225. 53270. 53315. 53360. 53405. 53450. 53495. 53540. 53585. 53630. 53675. 53720. 53765. 53810. 53855. 53900. 53945. 53990. 54035. 54080. 54125. 54170. 54215. 54260. 54305. 54350. 54395. 54440. 54485. 54530. 54575. 54620. 54665. 54710. 54755. 54800. 54845. 54890. 54935. 54980. 55025. 55070. 55115. 55160. 55205. 55250. 55295. 55340. 55385. 55430. 55475. 55520. 55565. 55610. 55655. 55700. 55745. 55790. 55835. 55880. 55925. 55970. 56015. 56060. 56105. 56150. 56195. 56240. 56285. 56330. 56375. 56420. 56465. 56510. 56555. 56600. 56645. 56690. 56735. 56780. 56825. 56870. 56915. 56960. 57005. 57050. 57095. 57140. 57185. 57230. 57275. 57320. 57365. 57410. 57455. 57500. 57545. 57590. 57635. 57680. 57725. 57770. 57815. 57860. 57905. 57950. 57995. 58040. 58085. 58130. 58175. 58220. 58265. 58310. 58355. 58400. 58445. 58490. 58535. 58580. 58625. 58670. 58715. 58760. 58805. 58850. 58895. 58940. 58985. 59030. 59075. 59120. 59165. 59210. 59255. 59300. 59345. 59390. 59435. 59480. 59525. 59570. 59615. 59660. 59705. 59750. 59795. 59840. 59885. 59930. 59975. 60020. 60065. 60110. 60155. 60200. 60245. 60290. 60335, 60380, 60425, 60470, 60515, 60560, 60605, 60650, 60695, 60740, 60785, 60830, 60875, 60920, 60965, 61010, 61055, 61100, 61145, 61190, 61235, 61280, 61325, 61370, 61415, 61460, 61505, 61550, 61595, 61640, 61685, 61730, 61775, 61820, 61865, 61910, 61955, 62000, 62045, 62090, 62135, 62180, 62225, 62270, 62315, 62360, 62405, 62450, 62495, 62540, 62585, 62630, 62675, 62720, 62765, 62810, 62855, 62900, 62945, 62990, 63035, 63080, 63125, 63170, 63215, 63260, 63305, 63350, 63395, 63440, 63485, 63530, 63575, 63620, 63665, 63710, 63755, 63800, 63845, 63890, 63935, 63980, 64025, 64070, 64115, 64160, 64205, 64250, 64295, 64340, 64385, 64430, 64475, 64520, 64565, 64610, 64655, 64700, 64745, 64790, 64835, 64880, 64925, 64970, 65015, 65060, 65105, 65150, 65195, 65240, 65285, 65330, 65375, 65420, 65465, 65510, 65555, 65600, 65645, 65690, 65735, 65780, 65825, 65870, 65915, 65960, 66005, 66050, 66095, 66140, 66185, 66230, 66275, 66320, 66365, 66410, 66455, 66500, 66545, 66590, 66635, 66680, 66725, 66770, 66815, 66860, 66905, 66950, 66995, 67040, 67085, 67130, 67175, 67220, 67265, 67310, 67355, 67400, 67445, 67490, 67535, 67580, 67625, 67670, 67715, 67760, 67805, 67850, 67895, 67940, 67985, 68030, 68075, 68120, 68165, 68210, 68255, 68300, 68345, 68390, 68435, 68480, 68525, 68570, 68615, 68660, 68705, 68750, 68795, 68840, 68885, 68930, 68975, 69020, 69065, 69110, 69155, 69200, 69245, 69290, 69335, 69380, 69425, 69470, 69515, 69560, 69605, 69650, 69695, 69740, 69785, 69830, 69875, 69920, 69965, 70010, 70055, 70100, 70145, 70190, 70235, 70280, 70325, 70370, 70415, 70460, 70505, 70550, 70595, 70640, 70685, 70730, 70775, 70820, 70865, 70910, 70955, 71000, 71045, 71090, 71135, 71180, 71225, 71270, 71315, 71360, 71405, 71450, 71495, 71540, 71585, 71630, 71675, 71720, 71765, 71810, 71855, 71900, 71945, 71990, 72035, 72080, 72125, 72170, 72215, 72260, 72305, 72350, 72395, 72440, 72485, 72530, 72575, 72620, 72665, 72710, 72755, 72800, 72845, 72890, 72935, 72980, 73025, 73070, 73115, 73160, 73205, 73250, 73295, 73340, 73385, 73430, 73475, 73520, 73565, 73610, 73655, 73700, 73745, 73790, 73835, 73880, 73925, 73970, 74015, 74060, 74105, 74150, 74195, 74240, 74285, 74330, 74375, 74420, 74465, 74510, 74555, 74600, 74645, 74690, 74735, 74780, 74825, 74870, 74915, 74960, 75005, 75050, 75095, 75140, 75185, 75230, 75275, 75320, 75365, 75410, 75455, 75500, 75545, 75590, 75635, 75680, 75725, 75770, 75815, 75860, 75905, 75950, 75995, 76040, 76085, 76130, 76175, 76220, 76265, 76310, 76355, 76400, 76445, 76490, 76535, 76580, 76625, 76670, 76715, 76760, 76805, 76850, 76895, 76940, 76985, 77030, 77075, 77120, 77165, 77210, 77255, 77300, 77345, 77390, 77435, 77480, 77525, 77570, 77615, 77660, 77705, 77750, 77795, 77840, 77885, 77930, 77975, 78020, 78065, 78110, 78155, 78200, 78245, 78290, 78335, 78380, 78425, 78470, 78515, 78560, 78605, 78650, 78695, 78740, 78785, 78830, 78875, 78920, 78965, 79010, 79055, 79100, 79145, 79190, 79235, 79280, 79325, 79370, 79415, 79460, 79505, 79550, 79595, 79640, 79685, 79730, 79775, 79820, 79865, 79910, 79955, 80000, 80045, 80090, 80135, 80180, 80225, 80270, 80315, 80360, 80405, 80450, 80495, 80540, 80585, 80630, 80675, 80720, 80765,

1	1.01	9.00	54	.01	.00	.01	1.02	9.00	198	.13	.11	.02	288.
2	1.01	9.10	55	.01	.00	.01	1.02	9.10	199	.13	.11	.02	292.
3	1.01	9.20	56	.01	.00	.01	1.02	9.20	200	.13	.11	.02	295.
4	1.01	9.30	57	.01	.00	.01	1.02	9.30	201	.13	.11	.02	298.
5	1.01	9.40	58	.01	.00	.01	1.02	9.40	202	.13	.11	.02	301.
6	1.01	9.50	59	.01	.00	.01	1.02	9.50	203	.13	.11	.02	304.
7	1.01	10.00	60	.01	.00	.01	1.02	10.00	204	.13	.11	.02	306.
8	1.01	10.10	61	.01	.00	.01	1.02	10.10	205	.13	.11	.02	309.
9	1.01	10.20	62	.01	.00	.01	1.02	10.20	206	.13	.11	.02	311.
10	1.01	10.30	63	.01	.00	.01	1.02	10.30	207	.13	.11	.02	313.
11	1.01	10.40	64	.01	.00	.01	1.02	10.40	208	.13	.11	.02	315.
12	1.01	10.50	65	.01	.00	.01	1.02	10.50	209	.13	.11	.02	317.
13	1.01	11.00	66	.01	.00	.01	1.02	11.00	210	.13	.11	.02	319.
14	1.01	11.10	67	.01	.00	.01	1.02	11.10	211	.13	.11	.02	320.
15	1.01	11.20	68	.01	.00	.01	1.02	11.20	212	.13	.11	.02	322.
16	1.01	11.30	69	.01	.00	.01	1.02	11.30	213	.13	.11	.02	323.
17	1.01	11.40	70	.01	.00	.01	1.02	11.40	214	.13	.11	.02	325.
18	1.01	11.50	71	.01	.00	.01	1.02	11.50	215	.13	.11	.02	326.
19	1.01	12.00	72	.01	.00	.01	1.02	12.00	216	.13	.11	.02	327.
20	1.01	12.10	73	.03	.00	.03	1.02	12.10	217	.44	.39	.05	337.
21	1.01	12.20	74	.03	.00	.03	1.02	12.20	218	.44	.39	.05	363.
22	1.01	12.30	75	.03	.00	.03	1.02	12.30	219	.44	.40	.04	415.
23	1.01	12.40	76	.03	.00	.03	1.02	12.40	220	.44	.40	.04	498.
24	1.01	12.50	77	.03	.00	.03	1.02	12.50	221	.44	.40	.04	599.
25	1.01	13.00	78	.03	.00	.03	1.02	13.00	222	.44	.41	.04	706.
26	1.01	13.10	79	.04	.00	.04	1.02	13.10	223	.53	.49	.04	810.
27	1.01	13.20	80	.04	.00	.04	1.02	13.20	224	.53	.49	.04	907.
28	1.01	13.30	81	.04	.00	.04	1.02	13.30	225	.53	.49	.04	955.
29	1.01	13.40	82	.04	.00	.04	1.02	13.40	226	.53	.50	.03	1074.
30	1.01	13.50	83	.04	.00	.04	1.02	13.50	227	.53	.50	.03	1146.
31	1.01	14.00	84	.04	.00	.04	1.02	14.00	228	.53	.50	.03	1271.
32	1.01	14.10	85	.05	.00	.05	1.02	14.10	229	.66	.63	.03	1370.
33	1.01	14.20	86	.05	.00	.05	1.02	14.20	230	.66	.63	.03	1330.
34	1.01	14.30	87	.05	.10	.04	1.02	14.30	231	.66	.63	.03	1392.
35	1.01	14.40	88	.05	.01	.04	1.02	14.40	232	.66	.64	.03	1459.
36	1.01	14.50	89	.05	.01	.04	1.02	14.50	233	.66	.64	.03	1528.
37	1.01	15.00	90	.05	.01	.04	1.02	15.00	234	.66	.64	.02	1595.
38	1.01	15.10	91	.05	.01	.04	1.02	15.10	235	.60	.58	.02	1654.
39	1.01	15.20	92	.08	.02	.06	1.02	15.20	236	1.01	.98	.02	1712.
40	1.01	15.30	93	.14	.04	.10	1.02	15.30	237	1.81	1.76	.05	1802.
41	1.01	15.40	94	.35	.11	.24	1.02	15.40	238	4.53	4.43	.10	2036.
42	1.01	15.50	95	.10	.04	.06	1.02	15.50	239	1.31	1.29	.02	2442.
43	1.01	16.00	96	.08	.02	.04	1.02	16.00	240	.81	.79	.01	3003.
44	1.01	16.10	97	.05	.02	.03	1.02	16.10	241	.62	.61	.01	3508.
45	1.01	16.20	98	.05	.02	.03	1.02	16.20	242	.62	.61	.01	3941.
46	1.01	16.30	99	.05	.02	.03	1.02	16.30	243	.62	.61	.01	4322.
47	1.01	16.40	100	.05	.02	.03	1.02	16.40	244	.62	.61	.01	3885.
48	1.01	16.50	101	.05	.02	.03	1.02	16.50	245	.62	.61	.01	3602.
49	1.01	17.00	102	.05	.02	.03	1.02	17.00	246	.62	.61	.01	3236.
50	1.01	17.10	103	.04	.02	.02	1.02	17.10	247	.49	.48	.01	2859.
51	1.01	17.20	104	.04	.02	.02	1.02	17.20	248	.49	.48	.01	2584.
52	1.01	17.30	105	.04	.02	.02	1.02	17.30	249	.49	.48	.01	2367.
53	1.01	17.40	106	.04	.02	.02	1.02	17.40	250	.49	.48	.01	2195.
54	1.01	17.50	107	.04	.02	.02	1.02	17.50	251	.49	.48	.01	2026.
55	1.01	18.00	108	.04	.02	.02	1.02	18.00	252	.49	.48	.01	1893.
56	1.01	18.10	109	.09	.00	.00	1.02	18.10	253	.04	.04	.00	1770.
57	1.01	18.20	110	.00	.00	.00	1.02	18.20	254	.04	.04	.00	1642.
58	1.01	18.30	111	.00	.00	.00	1.02	18.30	255	.04	.04	.00	1493.
59	1.01	18.40	112	.00	.00	.00	1.02	18.40	256	.04	.04	.00	1314.
60	1.01	18.50	113	.00	.00	.00	1.02	18.50	257	.04	.04	.00	1119.
61	1.01	19.00	114	.00	.00	.00	1.02	19.00	258	.04	.04	.00	926.
62	1.01	19.10	115	.00	.00	.00	1.02	19.10	259	.04	.04	.00	751.

Output Summary  
Various PMF Events  
The Place Dam  
MO 30996  
B7



PEAK FLOW AND STORAGE (END OF PERIOD) SUMMARY FOR MULTIPLE PLAN-RATIO ECONOMIC COMPUTATIONS  
 FLOWS IN CUBIC FEET PER SECOND (CUBIC METERS PER SECOND)  
 AREA IN SQUARE MILES (SQUARE KILOMETERS)

OPERATION	STATION	AREA	PLAN RATIO	1 RATIO	2 RATIO	3 RATIO	4 RATIO	RATIOS APPLIED TO FLOWS
				.25	.50	.75	1.00	
HYDROGRAPH AT LAKE		.76	1	1006.	2011.	3017.	4022.	
		1.97	1	28.47	56.95	85.42	113.90	
ADDED TO DAM		.76	1	850.	1037.	2948.	3949.	
		1.97	1	24.08	52.57	83.48	111.83	

SUMMARY OF DAM SAFETY ANALYSIS

PLAN 1	ELEVATION	INITIAL VALUE	SPILLWAY CREST	TOP OF DAM
		1047.40	1047.40	1051.70
STORAGE		94.	94.	180.
OUTFLOW		0.	0.	1418.

RATIO OF PMF	MAXIMUM RESERVOIR W.S.ELEV	MAXIMUM DEPTH OVER DAM	MAXIMUM STORAGE AC-FT	MAXIMUM OUTFLOW CFS	DURATION OVER TOP HOURS	TIME OF MAX OUTFLOW HOURS	TIME OF FAILURE HOURS
.25	1050.75	0.	159.	850.	0.	41.00	0.
.50	1052.18	.48	191.	1857.	1.33	40.83	0.
.75	1052.80	1.10	205.	2948.	2.50	40.67	0.
1.00	1053.22	1.92	215.	3949.	4.50	40.57	0.

Output Summary  
 Various PMF Events  
 The Place Dam  
 MO 30996

